

Base unit dimensions — 48A4,A5 060 RTPF

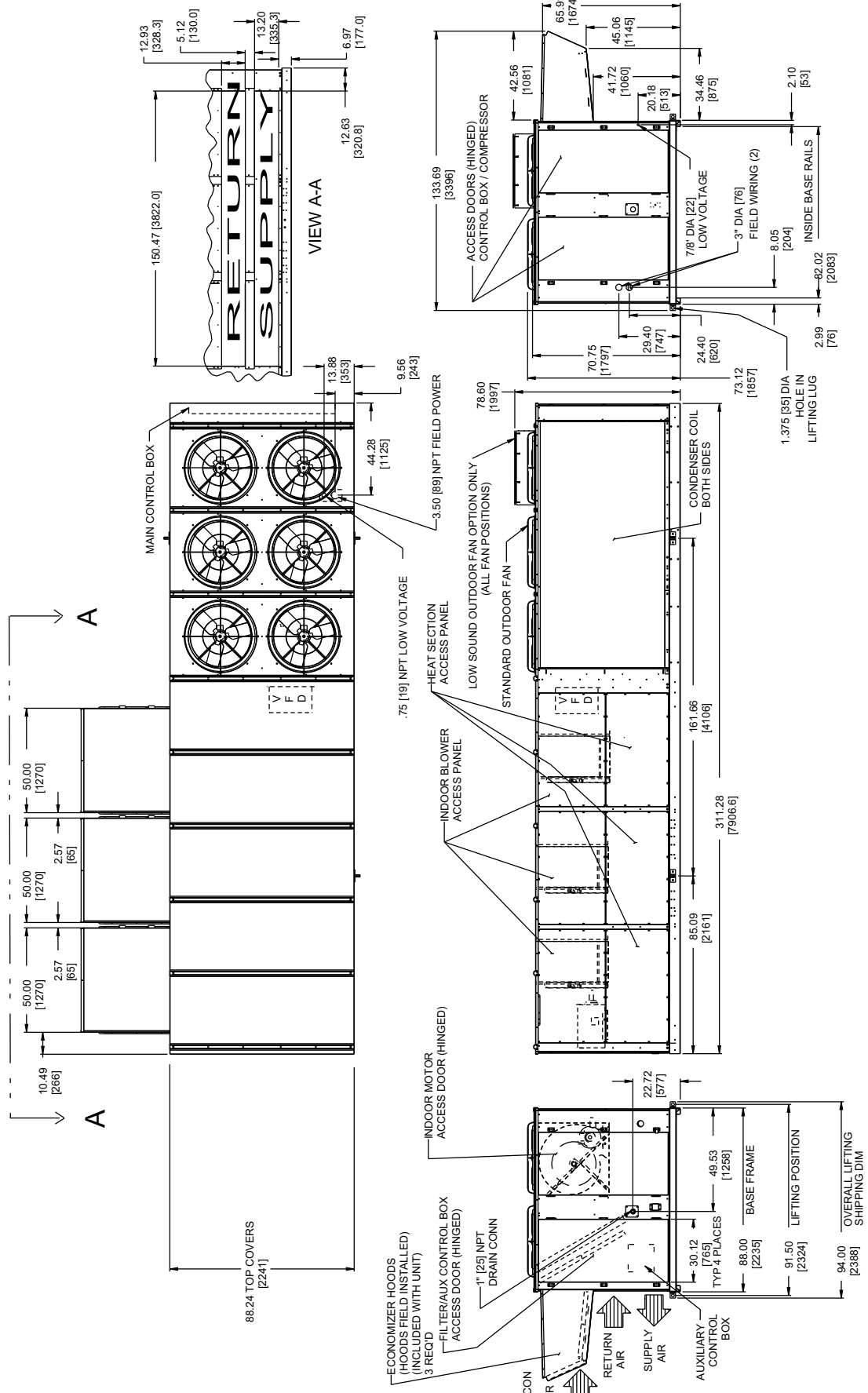

FOR CENTERS OF GRAVITY,
OPERATING AND CORNER
WEIGHTS, SEE PAGE 27



Base unit dimensions — 48A2,A3,A4,A5 060



CENTER OF GRAVITY AND WEIGHTS — 48A2,A3,A4,A5060

BASE UNIT WEIGHTS (SEE NOTE 7)	
	LB (KG)
	060
48A2D/A3D	7066 (3205)
48A2E/A3E	7306 (3314)
48A4D/A5D	7106 (3223)
48A4E/A5E	7356 (3337)
50A2/A3	6826 (3096)
50A4/A5	7041 (3194)
OPTIONS / ACCESSORIES (SEE NOTE 7)	
BAROMETRIC RELIEF	450 (204)
NON MOD. POWER EXHAUST	675 (306)
MOD. POWER EXHAUST	725 (329)
ELECTRIC HEAT	165 (75)
CU TUBAL FIN COND COIL	26 (12)
CU TUJCU FIN COND COIL	677 (307)

- NOTES:
- WEIGHTS INCLUDE ECONOMIZER OR OUTDOOR AIR DAMPER.
 - ⊕ CENTER OF GRAVITY.
 - FOR MULTIPLE UNIT APPLICATIONS SEE LITERATURE.
 - UNIT CLEARANCES:
TOP OF UNITS: NO OVERHANG
CU TUBE CONDENSER COIL: 4'-0" [1219]
HEAT SIDE: 4'-0" [1219]
FILTER ACCESS SIDE: 15'-0" [4572]
(FOR REMOVAL OF EVAPORATOR COIL)
ECONOMIZER SIDE: 6'-0" [1829] (FOR TUBE CONDENSER COILS)
8'-0" [2438] (FOR REMOVAL OF MCHX CONDENSER COILS)
 - FOR SMALLER SERVICE AND OPERATIONAL CLEARANCES, CONTACT CARRIER APPLICATION ENGINEERING DEPARTMENT.
 - BOTTOM DUCTS DESIGNED TO BE ATTACHED TO ACCESSORY ROOF CURB. IF UNIT IS MOUNTED ON DUNNAGE, IT IS RECOMMENDED THE DUCTS MUST BE SUPPORTED BY CROSS BRACES AS DONE ON ACCESSORY ROOF CURB.
 - BASE UNIT WEIGHTS INCLUDE OUTDOOR AIR HOODS, AND FILTERS (INDOOR FAN MOTOR IS NOT INCLUDED), ADD INDOOR MOTOR, FLOPS AND ACCESSORIES FOR TOTAL OPERATING WEIGHT.
 - VAV MOTOR WEIGHTS INCLUDE INDOOR MOTOR, VFD, VFD TRANSDUCEUR AND ASSOCIATED WIRING.
 - DIMENSIONS IN □ ARE IN MILLIMETERS, KILOGRAMS OR KILOWATTS.
 - FOR SIDE-SUPPLY/RETURN APPLICATIONS, A SINGLE RETURN AND SUPPLY DUCTWORK CONNECTION IS RECOMMENDED FOR COVERING ALL THREE RETURN AND ALL THREE SUPPLY OPENINGS. THE ENTIRE AREA AROUND THE DUCT OPENINGS IS AVAILABLE FOR A 1.5" DUCT FLANGE ATTACHMENT.

	CV MOTOR WEIGHTS		VAV MOTOR WEIGHTS	
	LB (KG)	PREMIUM EFFCY IFM	LB (KG)	PREMIUM EFFCY IFM
25 HP (18.65 kW)	230/460	240 (109)	309 (140)	375 (170)
	575	240 (109)	319 (145)	375 (170)
30 HP (22.38 kW)	230/460	283 (128)	355 (161)	418 (190)
	575	283 (128)	359 (163)	418 (190)
40 HP (29.84 kW)	230/460	372 (169)	415 (188)	507 (230)
	575	372 (169)	410 (186)	507 (230)

UNIT SIZE	OPERATING WEIGHT	CENTER OF GRAVITY				CORNER WEIGHT (LB)			
		A		B		1	2	3	4
	LBS	FT/IN	FT/IN	MM	MM				
48A2/A3 (D.M.S) 060	8386	14 - 9 5/8"	3 - 5 1/4"	4511	1049	866	768	1017	1153
48A2/A3 (E.N.T) 060	8626	14 - 2 3/8"	3 - 3 1/4"	4329	996	979	792	953	1189
48A4/A5 (D.M.S) 060	8426	14 - 1 5/8"	3 - 9 1/4"	4309	1149	800	940	1024	1058
48A4/A5 (E.N.T) 060	8676	13 - 7 1/4"	3 - 7 1/4"	4147	1087	907	964	968	1096
50A2/A3 060	8311	15 - 5"	3 - 7 3/8"	4698	1102	776	755	1104	1136
50A4/A5 060	8526	14 - 8 1/2"	3 - 11 1/8"	4484	1196	732	942	1127	1086

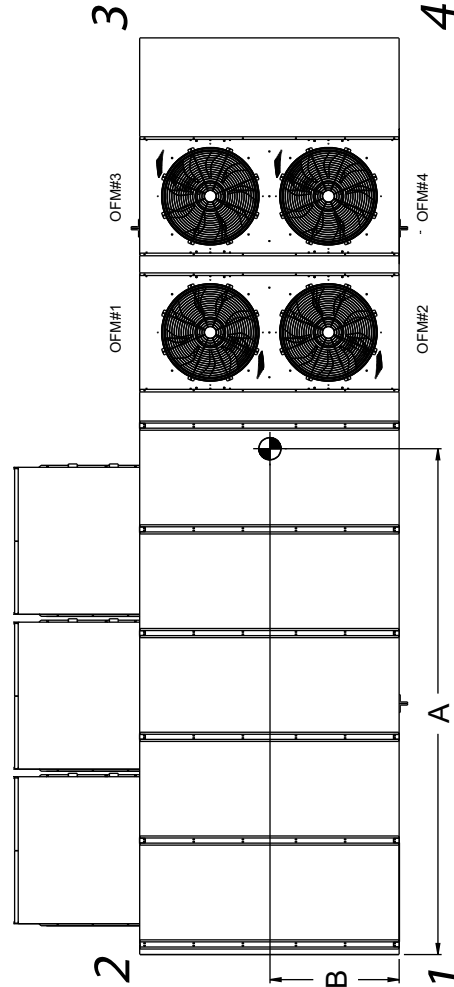

Base unit dimensions — 50A2,A3 020-035

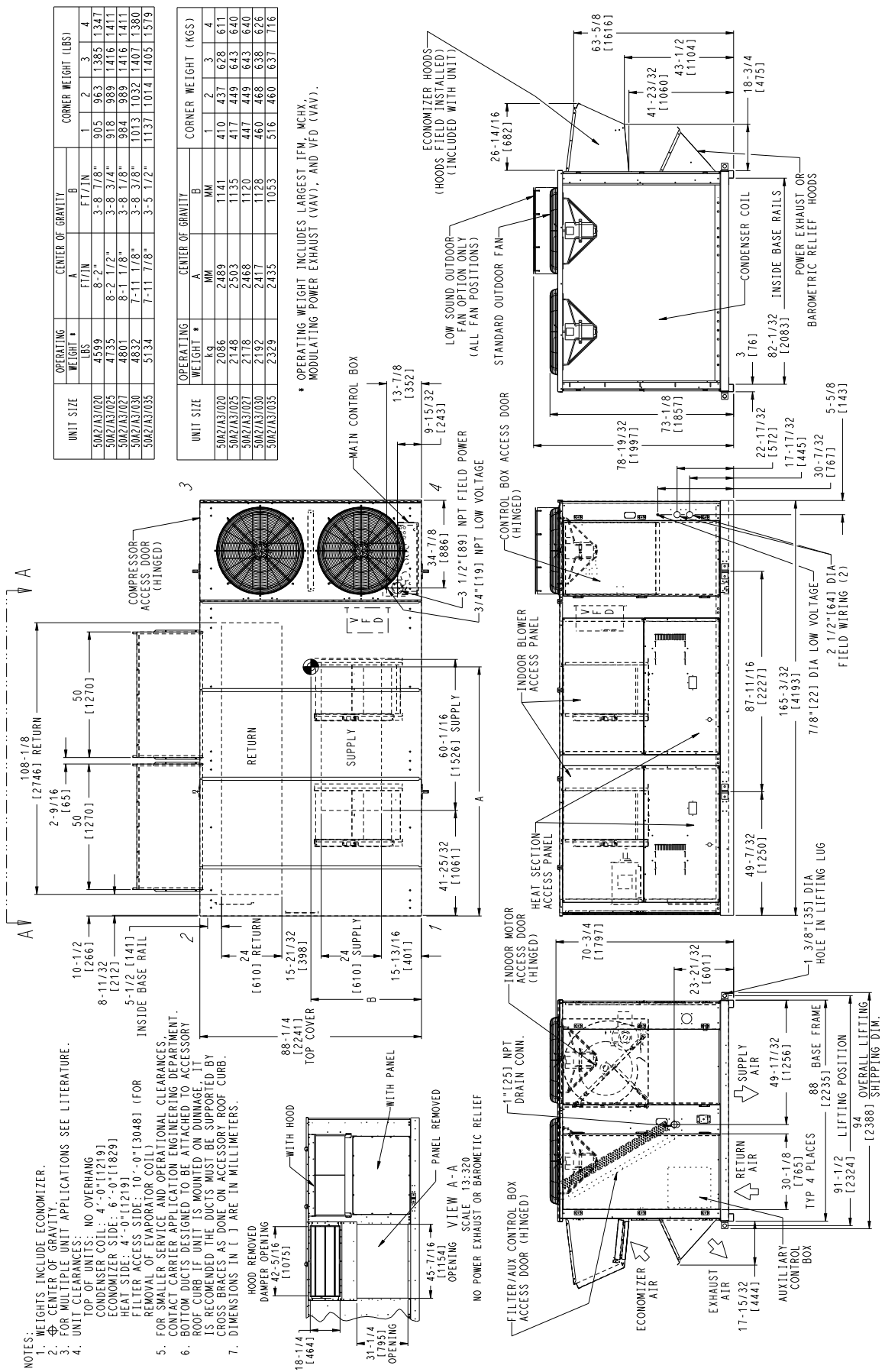

- NOTES:
- WEIGHTS INCLUDE ECONOMIZER.
 - CENTER OF GRAVITY.
 - FOR CLEARANCES SEE LITERATURE.
 - UNIT DIMENSIONS:
 - CONDENSER COIL: 10'-0" [3048] (FOR REMOVAL OF EVAPORATOR COIL)
 - FOR SMALLER SERVICE AND OPERATIONAL CLEARANCES, CONTACT CARRIER APPLICATION ENGINEERING DEPARTMENT.
 - BOTTOM DUCTS DESIGNED TO BE ATTACHED TO ACCESSORY ROOF CURB IF UNIT IS MOUNTED ON DUNNAGE. IT IS RECOMMENDED THE DUCTS MUST BE SUPPORTED BY CROSS BRACES AS BONE ON ACCESSORY ROOF CURB.
 - DIMENSIONS IN () ARE IN MILLIMETERS.

UNIT SIZE	OPERATING WEIGHT *		CENTER OF GRAVITY		CORNER WEIGHT (LBS)			
	WEIGHT (LBS)	WEIGHT (KGS)	A (FT./IN)	B (FT./IN)	1	2	3	4
50A2/43/020	4599	2086	8'-2"	3'-8 7/8"	905	963	1385	1347
50A2/43/025	4735	2148	8'-2 1/2"	3'-8 3/4"	918	989	1416	1411
50A2/43/027	4801	2178	8'-1 1/8"	3'-8 1/8"	984	989	1416	1411
50A2/43/030	4832	2192	7'-11 1/8"	3'-8 3/8"	1013	1032	1407	1380
50A2/43/035	5134	2329	7'-11 7/8"	3'-5 1/2"	1137	1014	1405	1579

UNIT SIZE	OPERATING WEIGHT *		CENTER OF GRAVITY		CORNER WEIGHT (KGS)			
	WEIGHT (LBS)	WEIGHT (KGS)	A (MM)	B (MM)	1	2	3	4
50A2/43/020	2086	2489	1141	1141	410	437	628	611
50A2/43/025	2148	2503	1135	1135	417	449	643	640
50A2/43/027	2178	2468	1120	1120	447	449	643	640
50A2/43/030	2192	2417	1128	1128	460	468	638	626
50A2/43/035	2329	2435	1053	1053	516	460	637	716

* OPERATING WEIGHT INCLUDES LARGEST IFM, MCHX, MODULATING POWER EXHAUST (VAV), AND VFD (VAV).

108-1/8 [2746] RETURN

2-9/16 [65] 50 [1270]

10-1/2 [266] 8-11/32 [212] 5-1/2 [141] INSIDE BASE RAIL

24 [610] RETURN 15-21/32 [398] 24 [610] SUPPLY 15-13/16 [401]

88-1/4 [2241] TOP COVER WITH HOOD 42-5/16 [11075] HOOD REMOVED DAMPER OPENING 45-7/16 [11541] PANEL REMOVED OPERATING VIEW A-A

SCALE: 13-320

NO POWER EXHAUST OR BAROMETRIC RELIEF

1"-[25] NPT DRAIN CONN.

70-3/4 [1797] INDOOR MOTOR ACCESS DOOR (HINGED)

23-21/32 [601] SUPPLY AIR 49-17/32 [1256] RETURN AIR 30-1/8 [765] TYP 4 PLACES 91-1/2 [2324] LIFTING POSITION 94 [2388] OVERALL LIFTING SHIPPING DIM.

1 3/8" [35] DIA HOLE IN LIFTING LUG

49-7/32 [1250] HEAT SECTION ACCESS PANEL

87-11/16 [2227] INDOOR BLOWER ACCESS PANEL

165-3/32 [4193] 7/8" [22] DIA LOW VOLTAGE FIELD WIRING (2)

5-5/8 [143] 30-7/32 [767] 17-17/32 [445] 22-47/32 [572] 17-1/32 [445]

78-19/32 [1997] 73-1/8 [1857] 26-14/16 [682] 41-23/32 [1060] 43-1/2 [1104] 63-5/8 [1616] 18-3/4 [475]

3 [76] 82-1/32 [2083] 3 [76] 26-14/16 [682]

CONSOLE OUTDOOR FAN (ALL FAN POSITIONS)

LOW SOUND OUTDOOR FAN OPTION ONLY

ECONOMIZER HOODS (HOODS FIELD INSTALLED) (INCLUDED WITH UNIT)

STANDARD OUTDOOR FAN

CONDENSER COIL INSIDE BASE RAILS

POWER EXHAUST OR BAROMETRIC RELIEF HOODS

3/4" [19] NPT LOW VOLTAGE FIELD POWER

13-7/8 [352] 9-15/32 [243] 34-7/8 [886] 3 1/2" [89] NPT FIELD POWER

MAIN CONTROL BOX

COMPRESSOR DOOR ACCESS DOOR (HINGED)

RETURN SUPPLY

108-1/8 [2746] RETURN

2-9/16 [65] 50 [1270]

10-1/2 [266] 8-11/32 [212] 5-1/2 [141] INSIDE BASE RAIL

24 [610] RETURN 15-21/32 [398] 24 [610] SUPPLY 15-13/16 [401]

88-1/4 [2241] TOP COVER WITH HOOD 42-5/16 [11075] HOOD REMOVED DAMPER OPENING 45-7/16 [11541] PANEL REMOVED OPERATING VIEW A-A

SCALE: 13-320

NO POWER EXHAUST OR BAROMETRIC RELIEF

1"-[25] NPT DRAIN CONN.

70-3/4 [1797] INDOOR MOTOR ACCESS DOOR (HINGED)

23-21/32 [601] SUPPLY AIR 49-17/32 [1256] RETURN AIR 30-1/8 [765] TYP 4 PLACES 91-1/2 [2324] LIFTING POSITION 94 [2388] OVERALL LIFTING SHIPPING DIM.

1 3/8" [35] DIA HOLE IN LIFTING LUG

49-7/32 [1250] HEAT SECTION ACCESS PANEL

87-11/16 [2227] INDOOR BLOWER ACCESS PANEL

165-3/32 [4193] 7/8" [22] DIA LOW VOLTAGE FIELD WIRING (2)

5-5/8 [143] 30-7/32 [767] 17-17/32 [445] 22-47/32 [572] 17-1/32 [445]

78-19/32 [1997] 73-1/8 [1857] 26-14/16 [682] 41-23/32 [1060] 43-1/2 [1104] 63-5/8 [1616] 18-3/4 [475]

3 [76] 82-1/32 [2083] 3 [76] 26-14/16 [682]

CONSOLE OUTDOOR FAN (ALL FAN POSITIONS)

LOW SOUND OUTDOOR FAN OPTION ONLY

ECONOMIZER HOODS (HOODS FIELD INSTALLED) (INCLUDED WITH UNIT)

STANDARD OUTDOOR FAN

CONDENSER COIL INSIDE BASE RAILS

POWER EXHAUST OR BAROMETRIC RELIEF HOODS

Base unit dimensions — 50A2,A3 040,050



UNIT SIZE	CENTER OF GRAVITY			CORNER WEIGHT (LB)			
	WEIGHT * LB	A FT./IN	B FT./IN	1	2	3	4
50A2/A3/040	5564	10 - 1 3/4*	3 - 5 3/8*	1276	1137	1481	1671
50A2/A3/050	5744	11 - 1 1/2*	3 - 5 3/4*	1338	1214	1509	1684

UNIT SIZE	CENTER OF GRAVITY			CORNER WEIGHT (KG)			
	WEIGHT * kg	A MM	B MM	1	2	3	4
50A2/A3/040	2524	3093	1052	579	516	672	758
50A2/A3/050	2606	3035	1059	607	551	684	764

*Operating weight includes largest indoor fan motor, micro-channel heat exchanger, modulating power exhaust (variable air volume units), and variable frequency drive (variable air volume units).

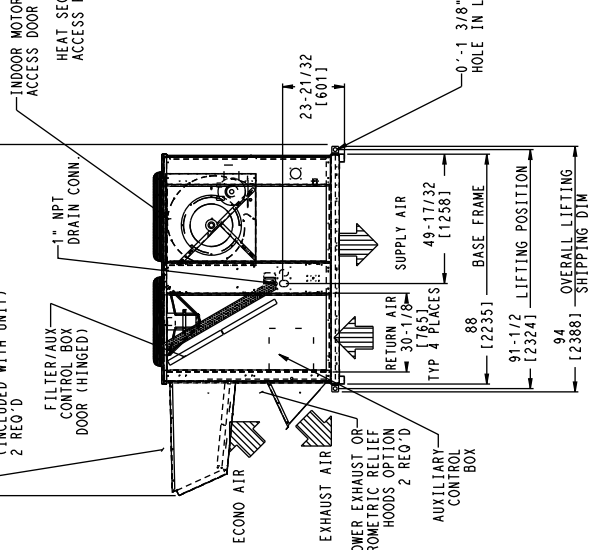
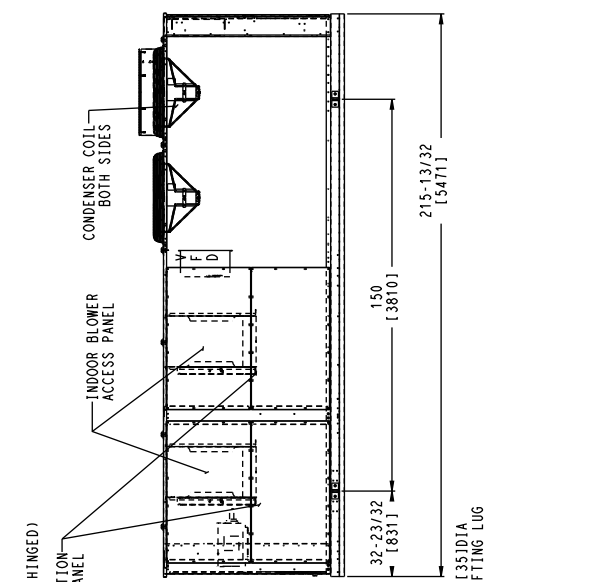
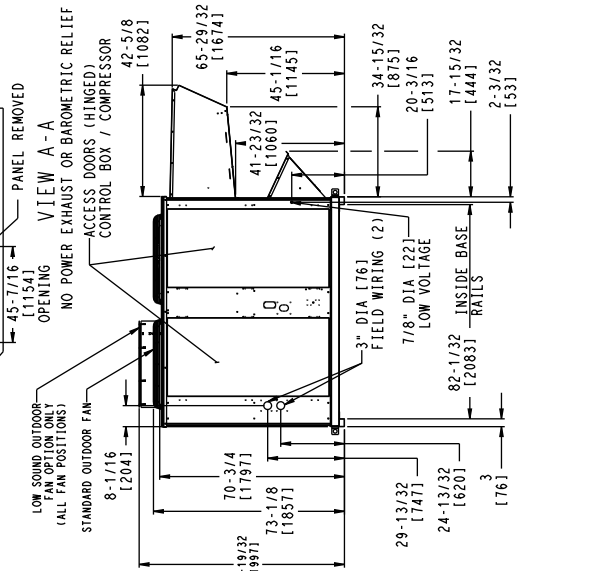
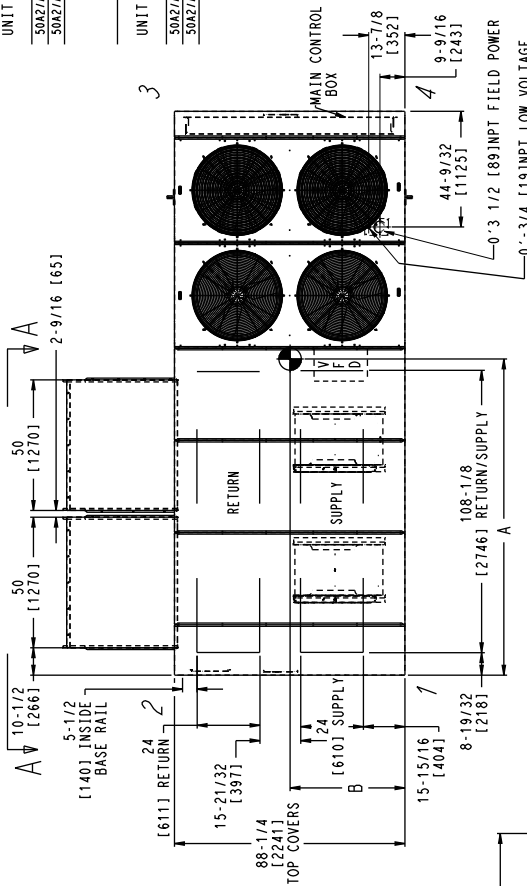

- NOTES:
- Weights include economizer.
 - Center of gravity. Top of units, no overhang.
 - Unit clearances: Top of units, no overhang. Economizer coil: 4 - 0 [1219]. Heat side: 6 - 0 [1629]. Filter access side: 10 - 0 [3048] (for removal of evaporator coil). For smaller service and operational clearances, contact Carrier application engineering department.
 - Bottom ducts are designed to be attached to accessory roof curb. If unit is mounted on damaged, it is recommended that the ducts be supported by cross braces as done on accessory roof curb.
 - Dimensions in [] are in millimeters. All other dimensions are in inches.

Base unit dimensions — 50A2,A3 060 MCHX



FOR CENTERS OF GRAVITY,
OPERATING AND CORNER
WEIGHTS, SEE PAGE 36

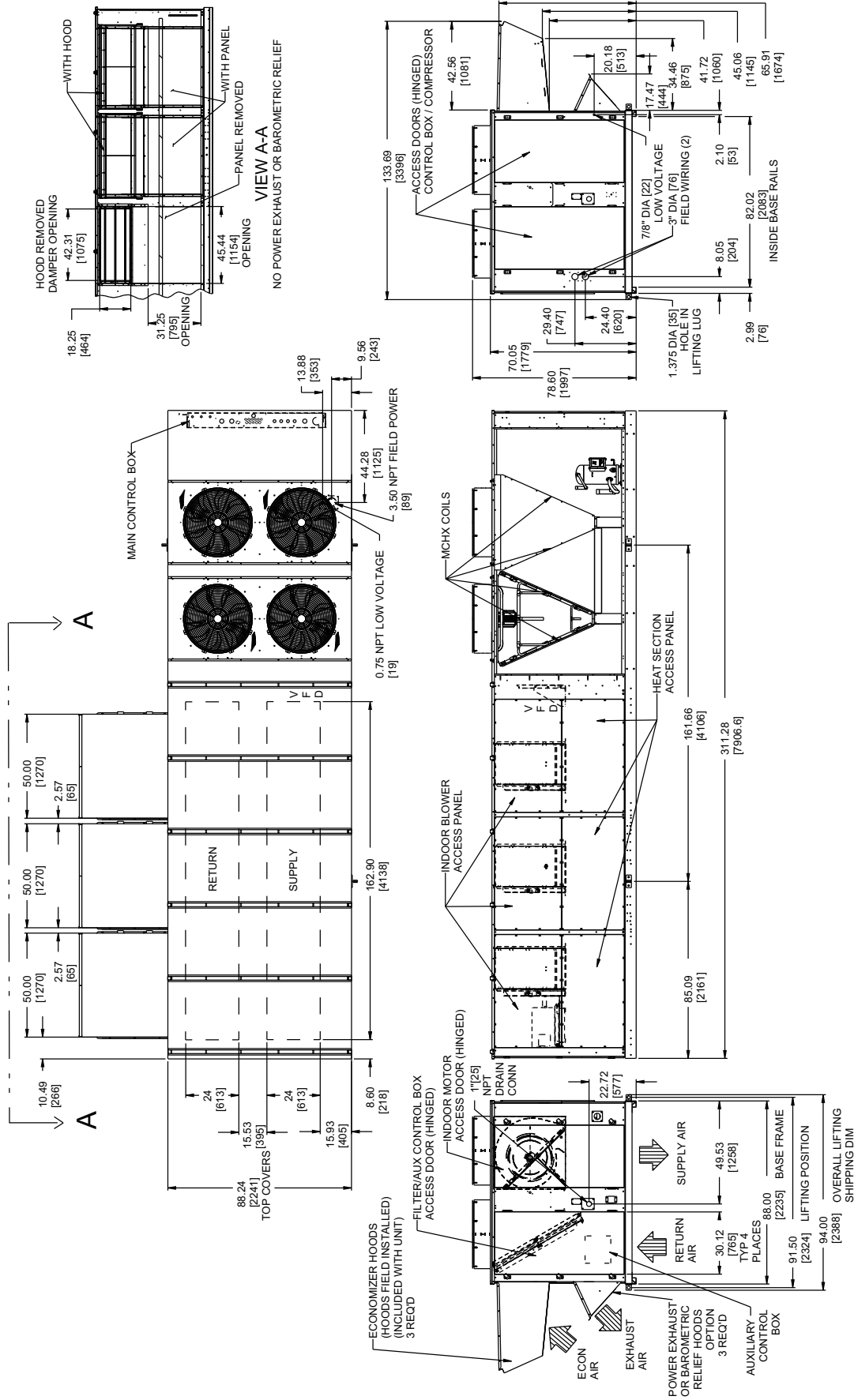

Base unit dimensions — 50A2,A3 060 RTPF



FOR CENTERS OF GRAVITY,
OPERATING AND CORNER
WEIGHTS, SEE PAGE 36

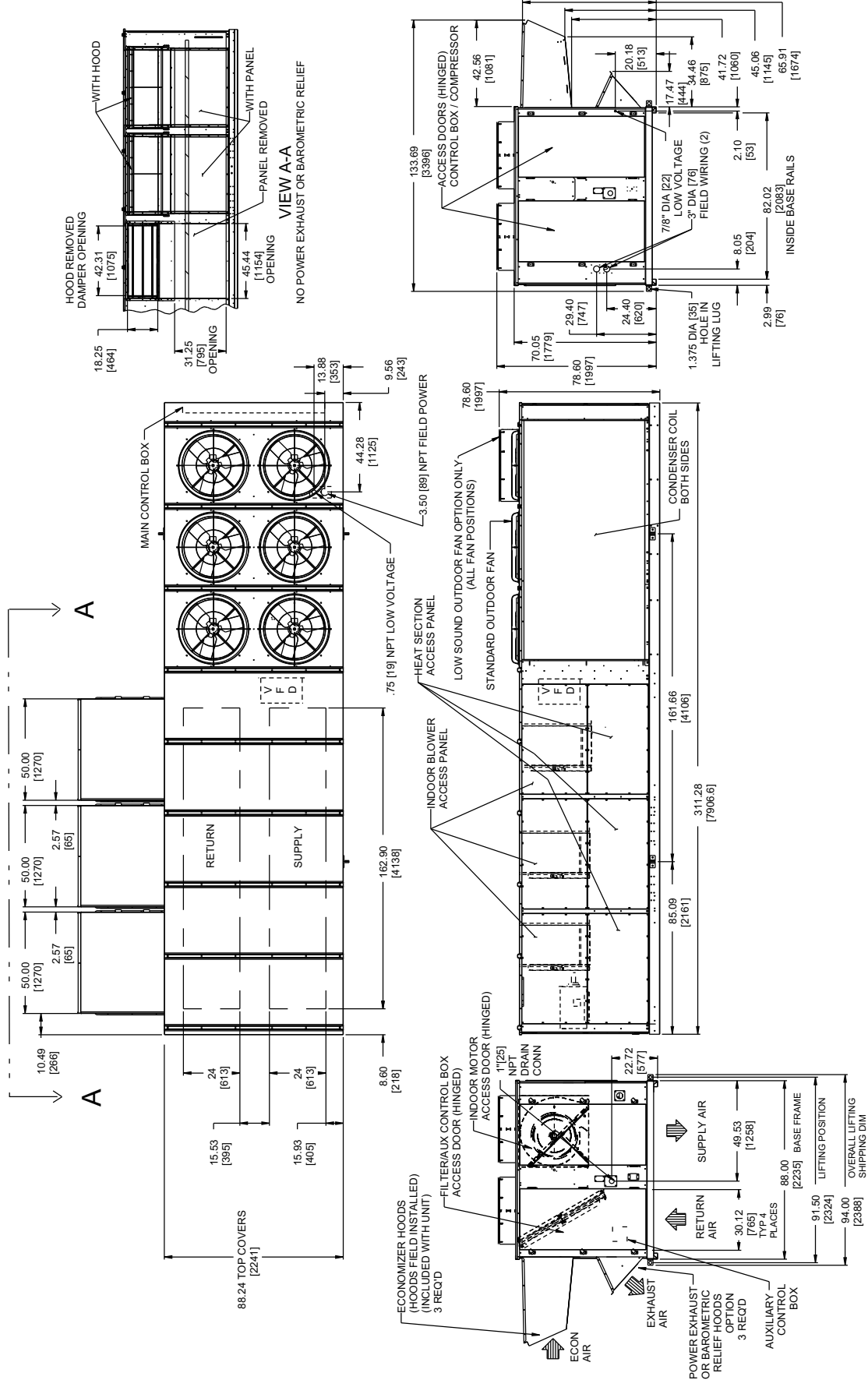

Base unit dimensions — 50A4,A5 020,035



NOTES:
 1. WEIGHTS INCLUDE ECONOMIZER.
 2. CENTER OF GRAVITY
 3. FOR MULTIPLE UNIT APPLICATION SEE LITERATURE.
 4. UNIT CLEARANCES:
 TOP OF UNITS: NO OVERHANG
 CONDENSER COIL: 4'-0" [1219]
 ECONOMIZER SIDE: 6'-0" [1829]
 HEAT SIDE: 4'-0" [1219]
 FILTER ACCESS SIDE: 10'-0" [3048] (FOR REMOVAL OF
 EVAPORATOR COIL)
 5. FOR SMALLER SERVICE AND OPERATIONAL CLEARANCES, CONTACT
 CARRIER APPLICATION ENGINEERING DEPARTMENT.
 6. DIMENSIONS IN [] ARE IN MILLIMETERS.

OPERATING WEIGHT INCLUDES
 LARGEST FAN, MCHX,
 MODULATING POWER EXHAUST
 (VAV), AND VFD (VAV).

UNIT SIZE	OPERATING WEIGHT (LBS)		CENTER OF GRAVITY		CORNER WEIGHT (LBS)	
	LBS	FT./IN.	A	B	1	2
50A4/A5/020	4677	7 - 10 1/4"	4 - 1 1/2"	821	1184	1446
50A4/A5/025	4813	7 - 10 1/8"	4 - 1 1/4"	835	1210	1478
50A4/A5/027	4819	7 - 9 5/8"	4 - 0 1/2"	901	1210	1478
50A4/A5/030	4910	7 - 7 5/8"	4 - 0 3/4"	931	1253	1467
50A4/A5/035	5327	7 - 8 5/8"	3 - 9 3/4"	1073	1263	1506

UNIT SIZE	OPERATING WEIGHT (KGS)		CENTER OF GRAVITY		CORNER WEIGHT (KGS)	
	kg	MM	A	B	1	2
50A4/A5/020	2122	2394	373	537	656	556
50A4/A5/025	2183	2410	379	549	670	585
50A4/A5/027	2213	2377	409	549	670	585
50A4/A5/030	2227	2327	422	568	666	571
50A4/A5/035	2416	2353	487	573	683	674

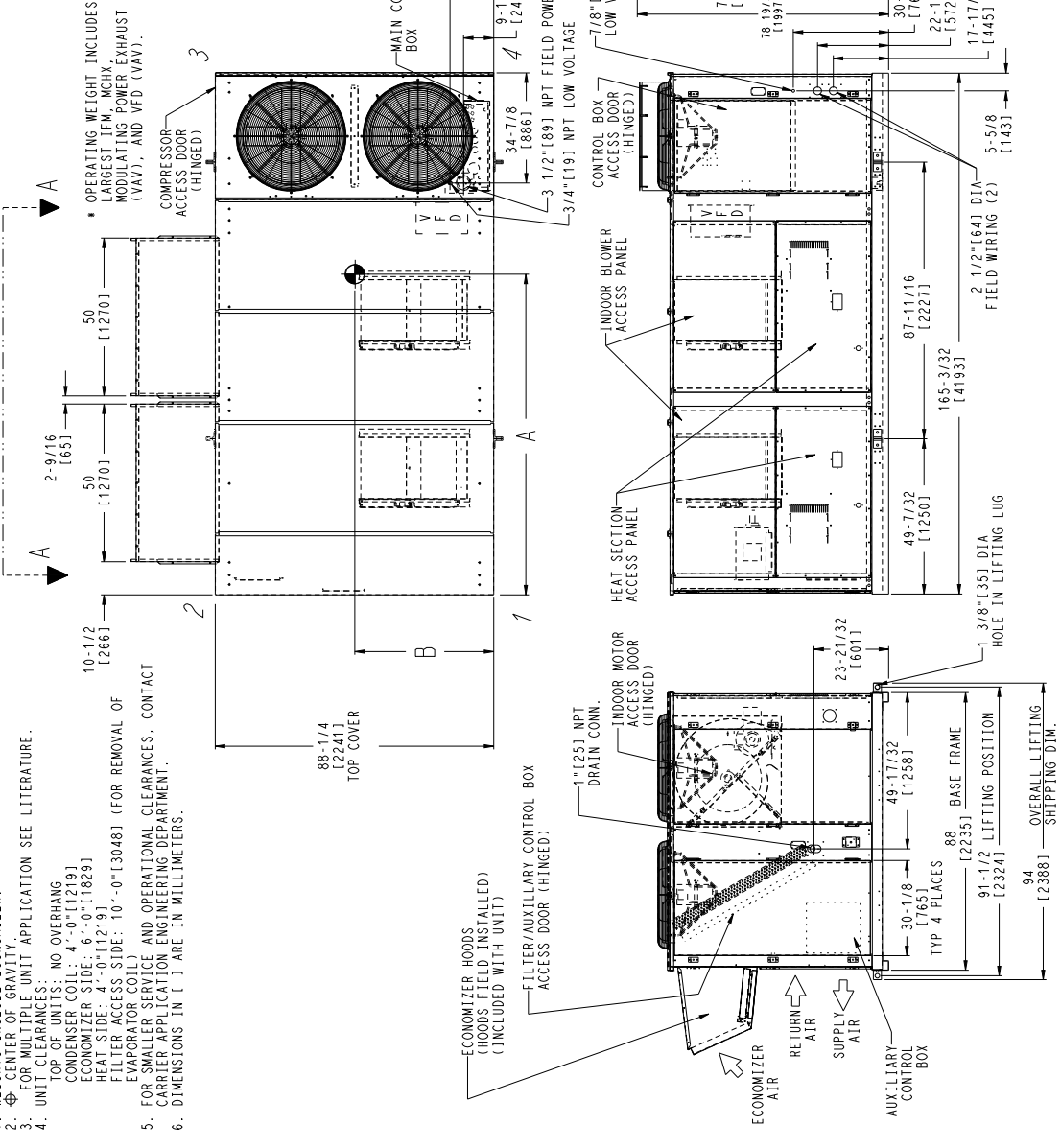

Base unit dimensions — 50A4, A5 040, 050



UNIT SIZE	OPERATING WEIGHT * (LB)	CENTER OF GRAVITY		CORNER WEIGHT (LB)			
		A	B	1	2	3	4
50A4/A5/040	5157	9-8 1/2"	3-9 3/8"	1211	1428	1540	1518
50A4/A5/050	5937	9-6 1/4"	3-9 1/2"	1276	1505	1566	1591

UNIT SIZE	OPERATING WEIGHT * (KG)	CENTER OF GRAVITY		CORNER WEIGHT (KG)			
		A	B	1	2	3	4
50A4/A5/040	2632	2958	1152	549	648	689	716
50A4/A5/050	2893	2904	1156	579	683	710	722

*Operating weight includes largest indoor fan motor, micro-channel heat exchanger, modulating power exhaust (variable air volume units), and variable frequency drive (variable air volume units).

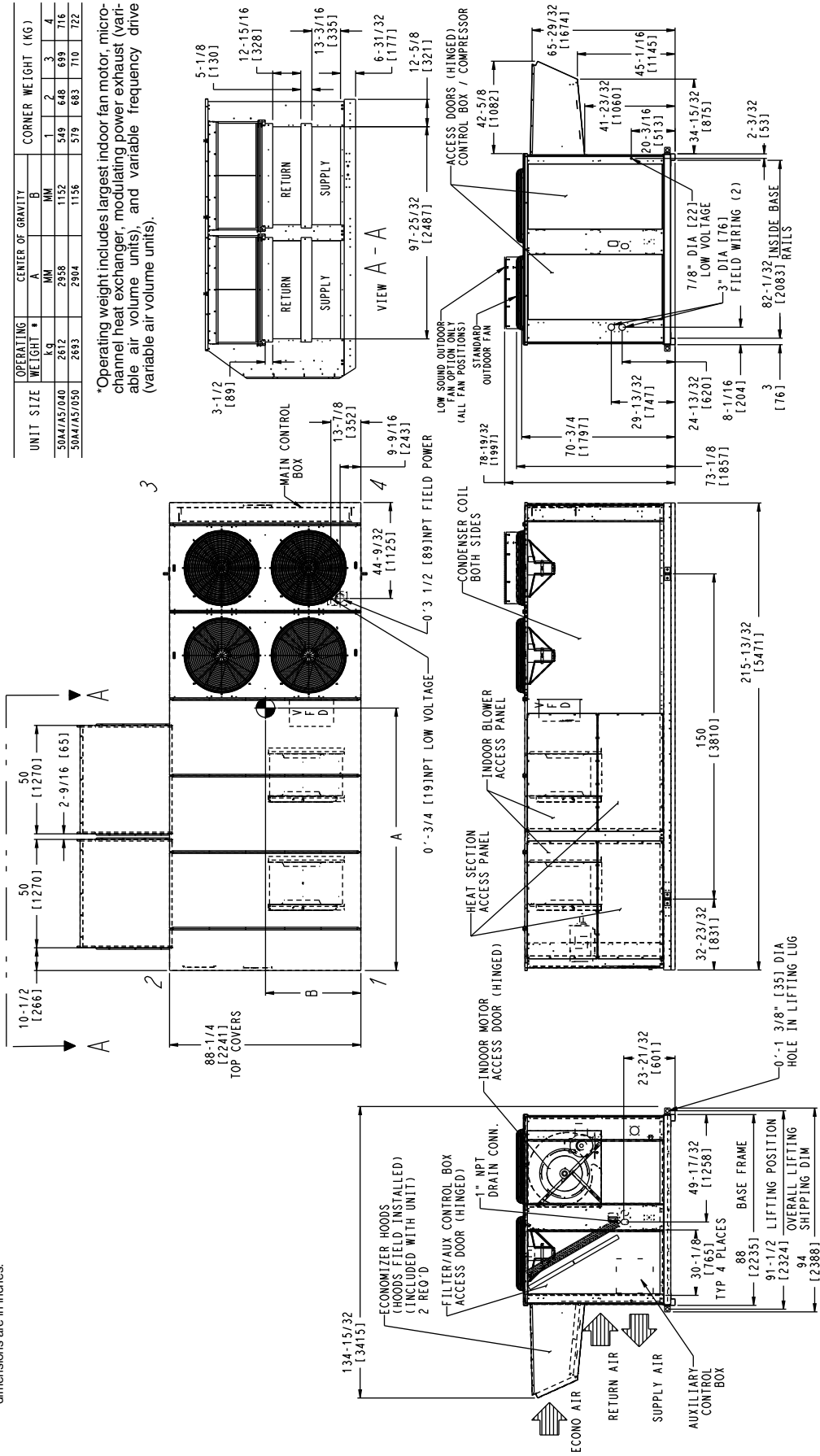

- NOTES:**
- Weights include economizer.
 - Center of gravity.
 - Unit clearances:
 - Top of units, no overhang
 - Economizer side, 4'-0" [1219]
 - Condenser side, 6'-0" [1829]
 - Heat side, 4'-0" [1219]
 - Filter access side, 10'-0" [3048] (for removal of evaporator coil)
 - For smaller service and operational clearances, contact Carrier application engineering department.
 - Dimensions in [] are in millimeters. All other dimensions are in inches.

Base unit dimensions — 50A4,A5 060 MCHX



FOR CENTERS OF GRAVITY,
OPERATING AND CORNER
WEIGHTS, SEE PAGE 36

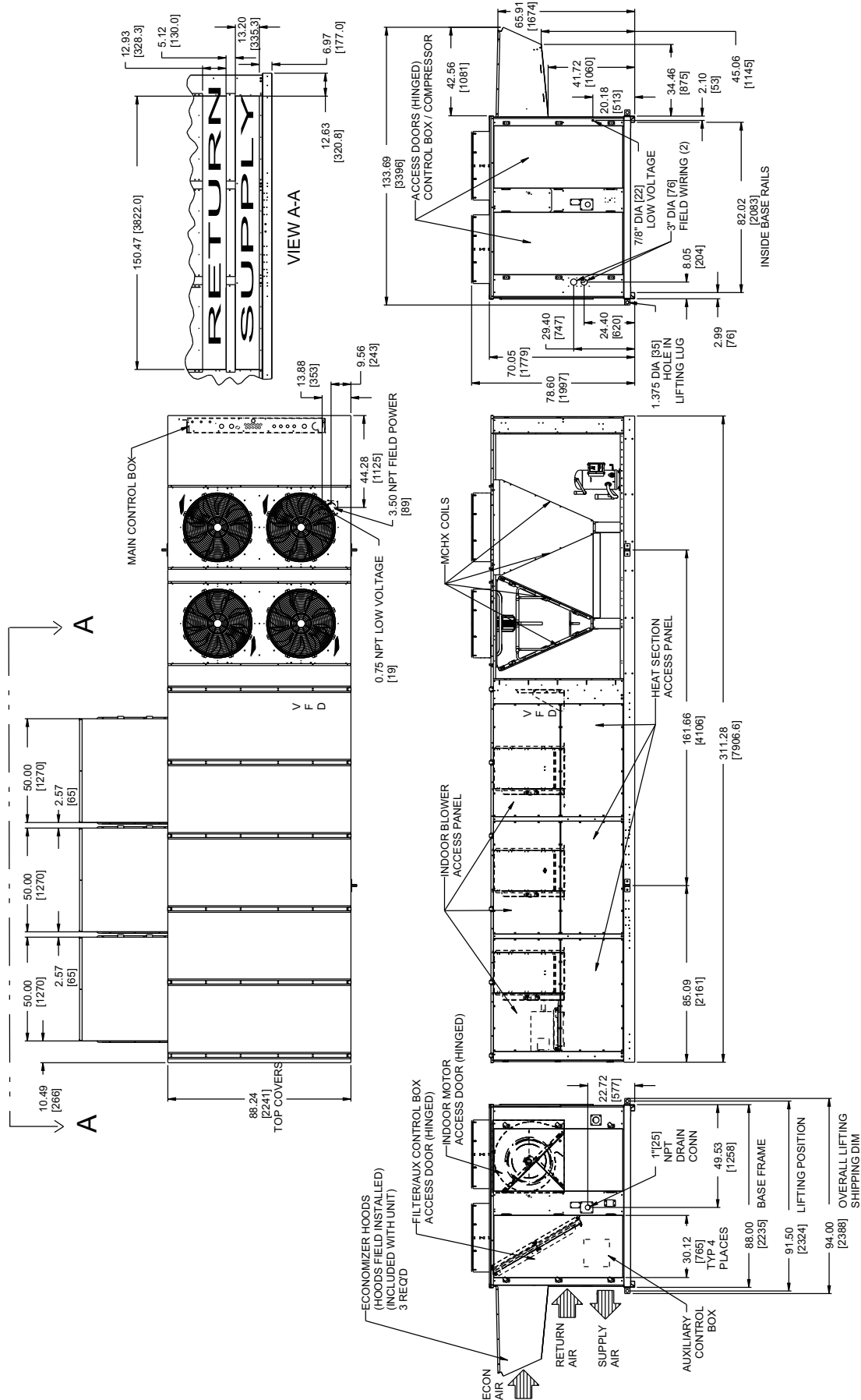

Base unit dimensions — 50A4,A5 060 RTPF



FOR CENTERS OF GRAVITY,
OPERATING AND CORNER
WEIGHTS, SEE PAGE 36

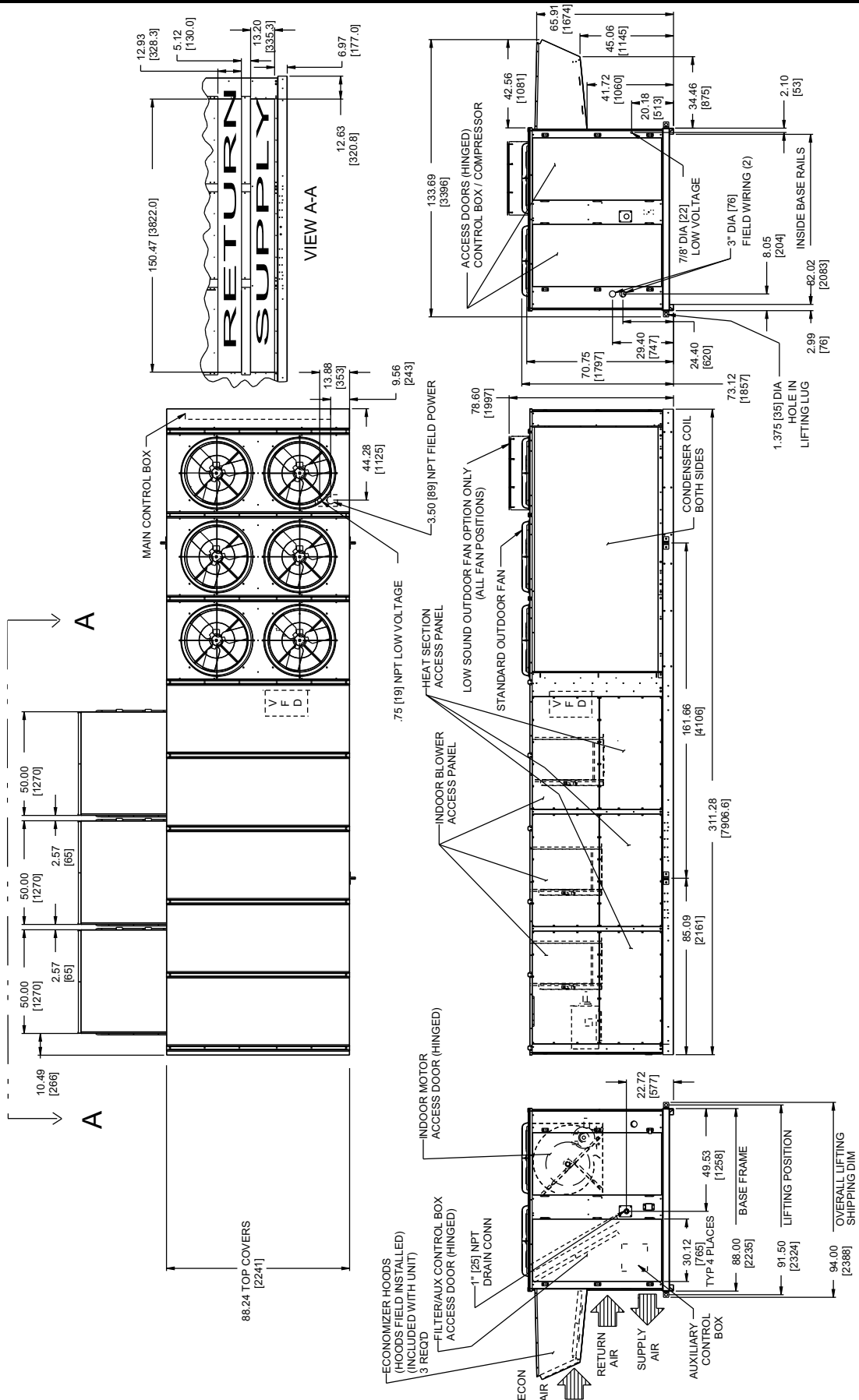

Base unit dimensions — 50A2,A3,A4,A5 060



CENTER OF GRAVITY AND WEIGHTS — 50A2,A3,A4,A5060

- NOTES:**
- Weights include economizer or outdoor air damper, center of gravity.
 - Unit clearances.
 - Top of units: no overhang.
Condenser coil: 4" - 0" [1219]
Economizer side: 6" - 0" [1829]
Heat side: 4" - 0" [1219]
Filter access side: 10" - 0" [3048] (for removal of evaporator coil)
 - For smaller service and operational clearances, contact Carrier application engineering department.
 - Bottom ducts are designed to be attached to accessory roof curb. If unit is mounted on downpipe, it is recommended that the ducts be supported by cross braces as done on accessory roof curb.
 - Base unit weights include outdoor air hoods and filters (indoor fan motor is not included). Add indoor fan motor, FIOPs, and accessories for total operating weight.
 - VAV motor weights include indoor motor, VFD, VFD transducer, and associated wiring.
 - Dimensions in [] are in millimeters. All other dimensions are in inches.
 - For side-supply/return applications, a single return and supply ductwork connection is recommended for covering all three return and all three supply openings. The entire area around the duct openings is available for a 1.5" duct flange attachment.

BASE UNIT WEIGHTS (SEE NOTE 5)	LB (kg)
50A2/A3	6826 (3096)
50A4/A5	7041 (3194)

OPTIONS / ACCESSORIES (SEE NOTE 5)	
BAROMETRIC RELIEF	450 (204)
NON MOD. POWER EXHAUST	675 (306)
MOD. POWER EXHAUST	725 (329)
ELECTRIC HEAT	165 (75)
CU TU/AL FIN COND COIL	26 (112)
CU TU/CU FIN COND COIL	677 (307)

UNIT SIZE	OPERATING WEIGHT	CENTER OF GRAVITY		CORNER WEIGHT (LB)			
		A	B	1	2	3	4
50A2/A3 060	8311	15 - 5"	3 - 7 3/8"	1710	1663	2433	2504
50A4/A5 060	8526	14 - 8 1/2"	3 - 11 1/8"	1613	2078	2484	2351

UNIT SIZE	OPERATING WEIGHT	CENTER OF GRAVITY		CORNER WEIGHT (kg)			
		A	B	1	2	3	4
50A2/A3 060	3770	4698	1102	776	755	1104	1136
50A4/A5 060	3868	4484	1196	732	942	1127	1066

*Operating weight includes largest indoor fan motor, microchannel heat exchanger, modulating power exhaust (variable air volume units), and variable frequency drive (variable air volume units).

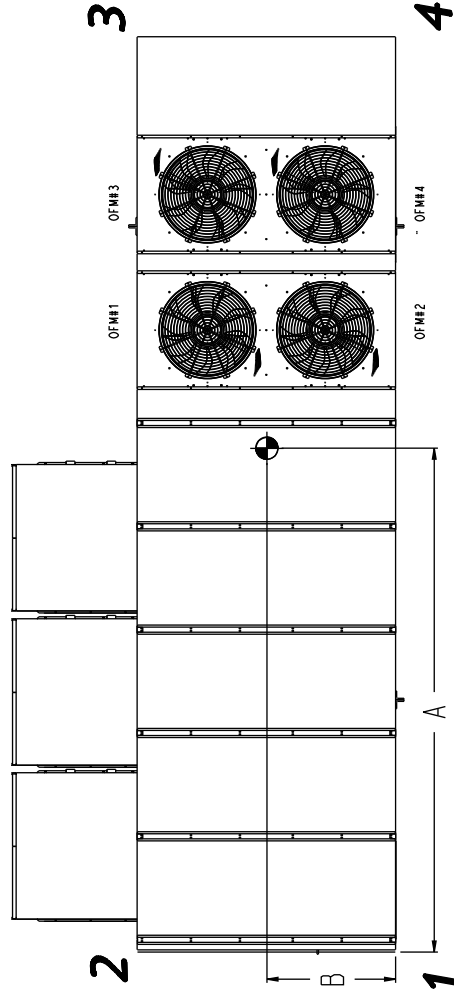

	CV MOTOR WEIGHTS LB (kg)			VAV MOTOR WEIGHTS LB (kg) (SEE NOTE 6)		
	HIGH EFFC*Y IFM	PREMIUM EFFC*Y IFM		HIGH EFFC*Y IFM	PREMIUM EFFC*Y IFM	
25 HP (18.65 kW)	240 (109)	309 (140)	575	375 (170)	444 (201)	575
30 HP (22.38 kW)	283 (128)	355 (161)	575	418 (190)	490 (222)	575
40 HP (29.84 kW)	372 (169)	415 (188)	575	507 (230)	550 (249)	575

Accessory dimensions

ROOF CURB SIZES 020-035

NOTES:

1. Unless otherwise specified, all dimensions are to outside of part.
2. Roof curb accessory CRRFCURB005A00 is shipped disassembled.
3. All roof curb parts are to be 14 ga. galvanized steel.
4. Units with electric heat must be installed with a 90° elbow on the supply duct prior to any supply take offs or branches.
5. Dimensions in [] are in millimeters. All other dimensions are in inches.

NOTE: TO PREVENT STANDING WATER IN THE DRAIN PAN OF THE INDOOR SECTION, AND THE HEAT EXCHANGERS UNIT CAN ONLY BE PITCHED AS SHOWN.

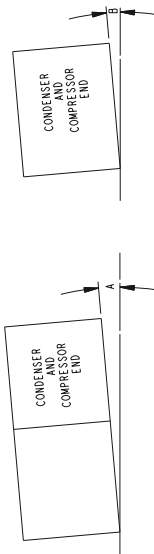

DIMENSIONS (DEGREES AND INCHES)

A	B				
BEG. IN.	BEG. IN.				
BEG. MM	BEG. MM				
1.0	2.9	73	50	75	19

UNIT LEVELING TOLERANCES
*FROM EDGE OF UNIT TO HORIZONTAL

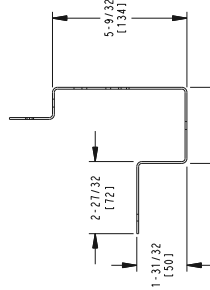
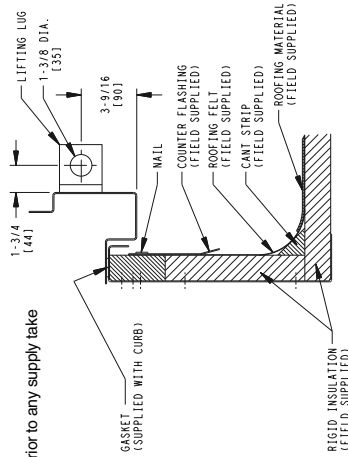

BASE RAIL CROSS SECTION
TYP 2 SIDES

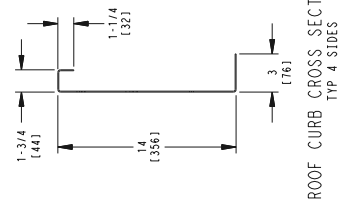

ROOF CURB CROSS SECTION
TYP 4 SIDES

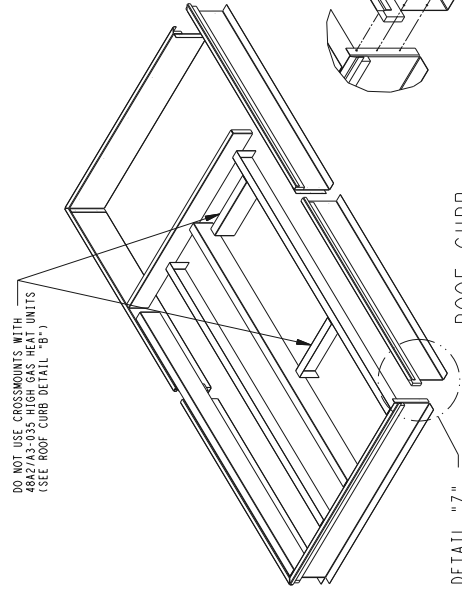

DETAIL "Z"
SCALE 1:8
TYP 4 CORNERS

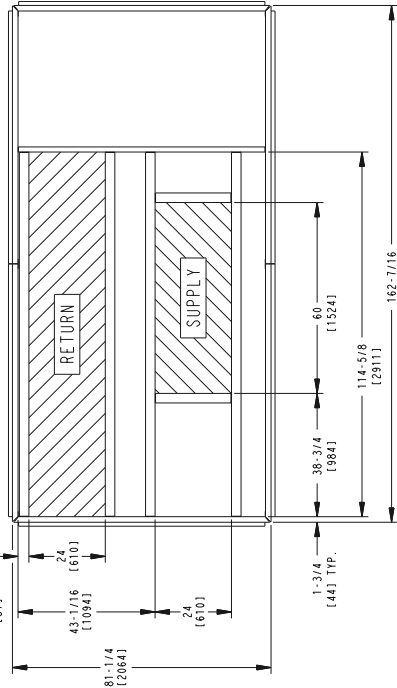

ROOF CURB DETAIL "A"
(ALL OTHERS)

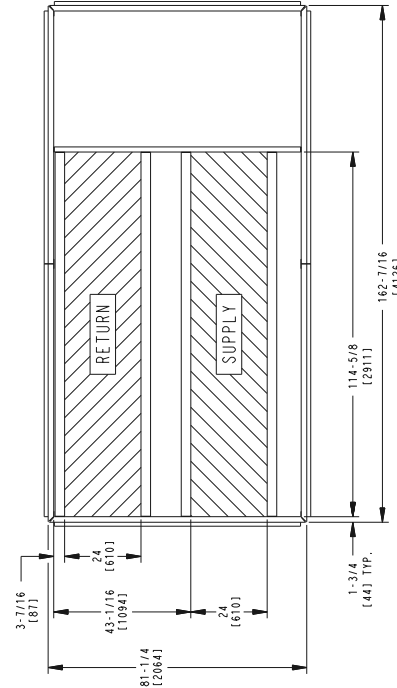

ROOF CURB DETAIL "B"
(48A2/A3-035 HIGH GAS HEAT ONLY)

Accessory dimensions (cont)

ROOF CURB SIZES 040 AND 050

NOTES:

1. Unless otherwise specified, all dimensions are to outside of part.
2. Roof curb accessory CRHF-CURB06A00 is shipped disassembled.
3. All roof curb parts are to be 1/4 galv. galvanized steel.
4. Units with electric heat must be installed with a 90° elbow on the supply duct prior to any supply take offs or branches.
5. Dimensions in [] are in millimeters. All other dimensions are in inches.

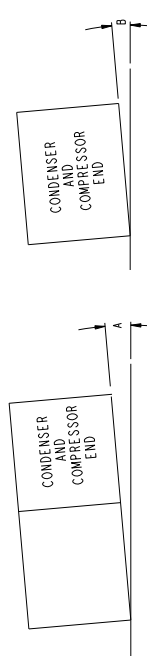
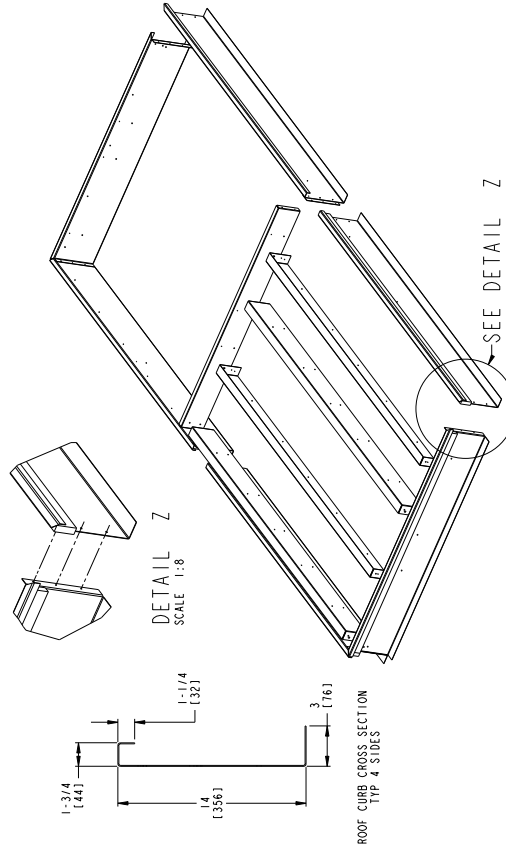
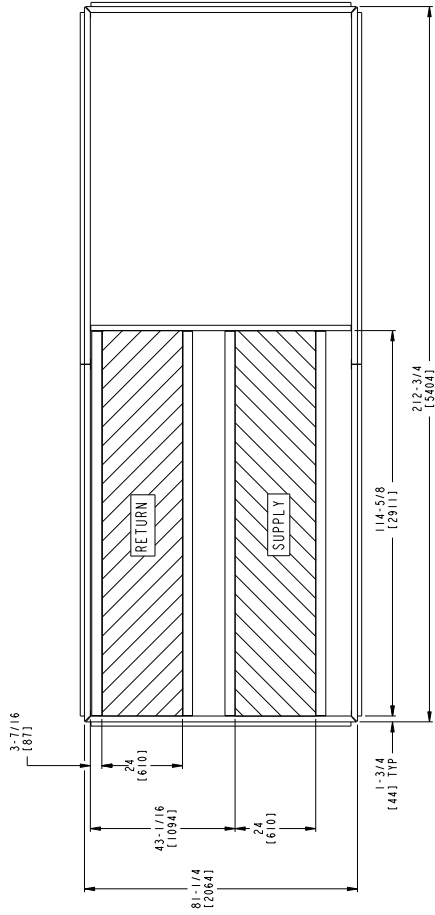

NOTE: TO PREVENT STANDING WATER IN THE DRAIN PAN OF THE ROOF CURB, THE CONDENSER AND COMPRESSOR END OF THE UNIT CAN ONLY BE PITCHED AS SHOWN.

DIMENSIONS (DEGREES AND INCHES)

A		B	
DEG.	IN.	DEG.	IN.
1.0	2.9	73	.50
			.75
			1.9

UNIT LEVELING TOLERANCES
*FROM EDGE OF UNIT TO HORIZONTAL

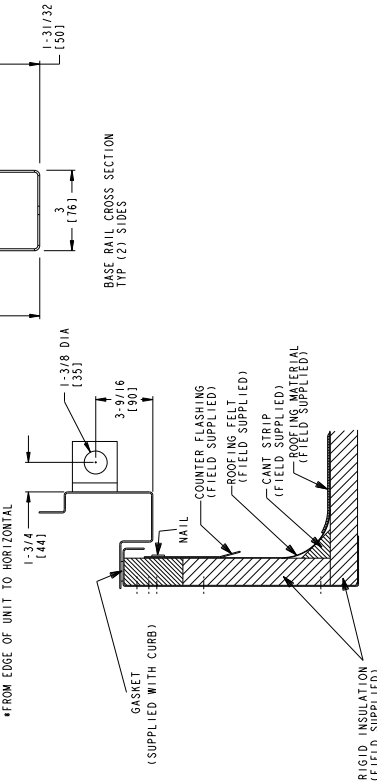

ROOF CURB 48A2,A3060, 50A2,A3060 WITHOUT ELECTRIC HEAT/UNIT SUPPORT 48/50A4,A5060

- NOTES:**
1. Unless otherwise specified, all dimensions are to outside of part.
 2. Roof curb accessory CUREFCURB014A00 is shipped disassembled.
 3. All roof curb parts are to be 14 ga. galvanized steel.
 4. Dimensions in [] are in millimeters. All other dimensions are in inches.

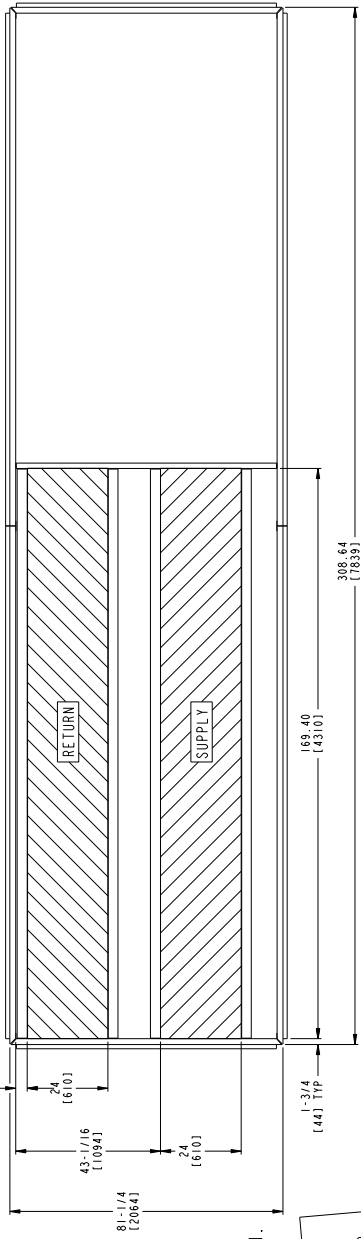

NOTE:
TO PREVENT STANDING WATER IN THE DRAIN PAN OF THE INDOOR SECTION, AND THE HEAT EXCHANGERS UNIT CAN ONLY BE PITCHED AS SHOWN.

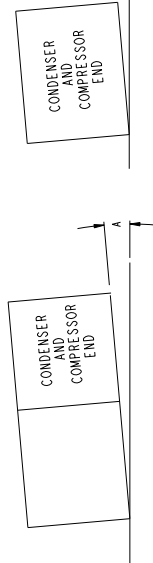

DIMENSIONS
(DEGREES AND INCHES)

A		B	
DEG.	IN.	DEG.	IN.
1.0	5.43	1.38	.50
			.75
			1.19

UNIT LEVELING TOLERANCES
*FROM EDGE OF UNIT TO HORIZONTAL

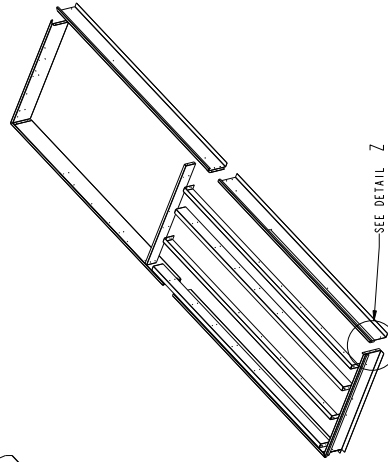
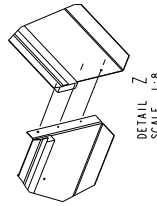
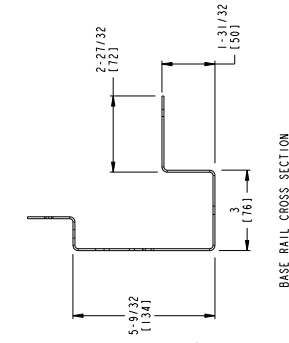
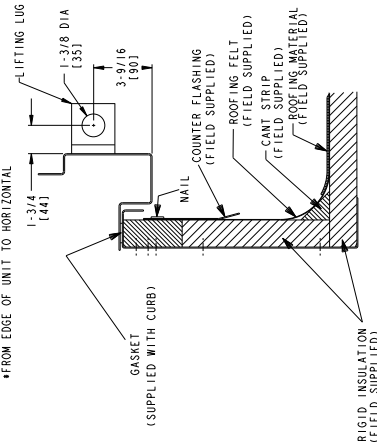

Accessory dimensions (cont)

ROOF CURB 50A2.A3060 WITH ELECTRIC HEAT

NOTES:

1. Unless otherwise specified, all dimensions are to outside of part.
2. Roof curb accessory CRRFCURB009A00 is shipped disassembled.
3. All roof curb parts are to be 14 ga. galvanized steel.
4. Units with electric heat must be installed with a 90° elbow on the supply duct prior to any supply take offs or branches.
5. Dimensions in [] are in millimeters. All other dimensions are in inches.

NOTE:
TO PREVENT STANDING WATER IN THE DRAIN PAN OF THE
ROOF CURB SECTION, THE HEAT EXCHANGERS
UNIT CAN ONLY BE PITCHED AS SHOWN.

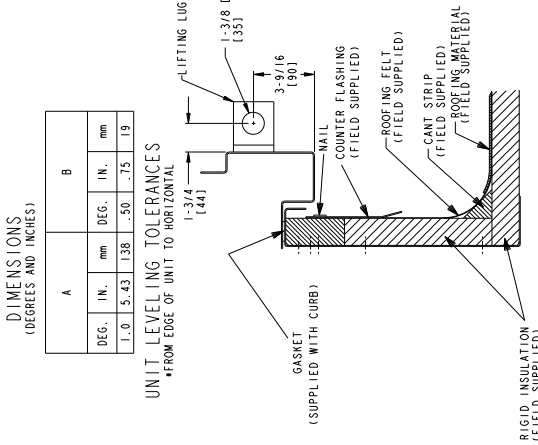
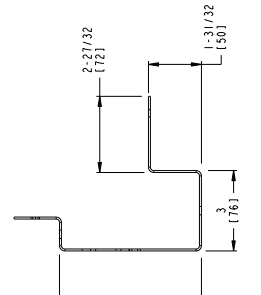
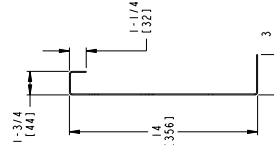
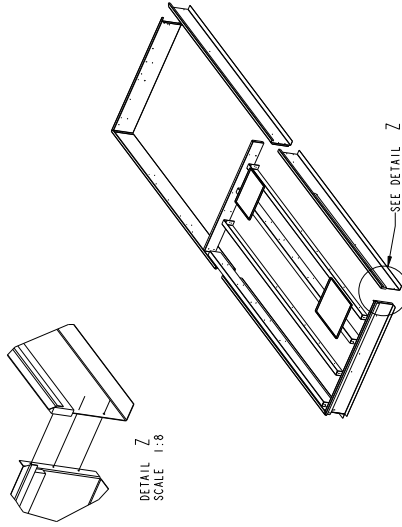
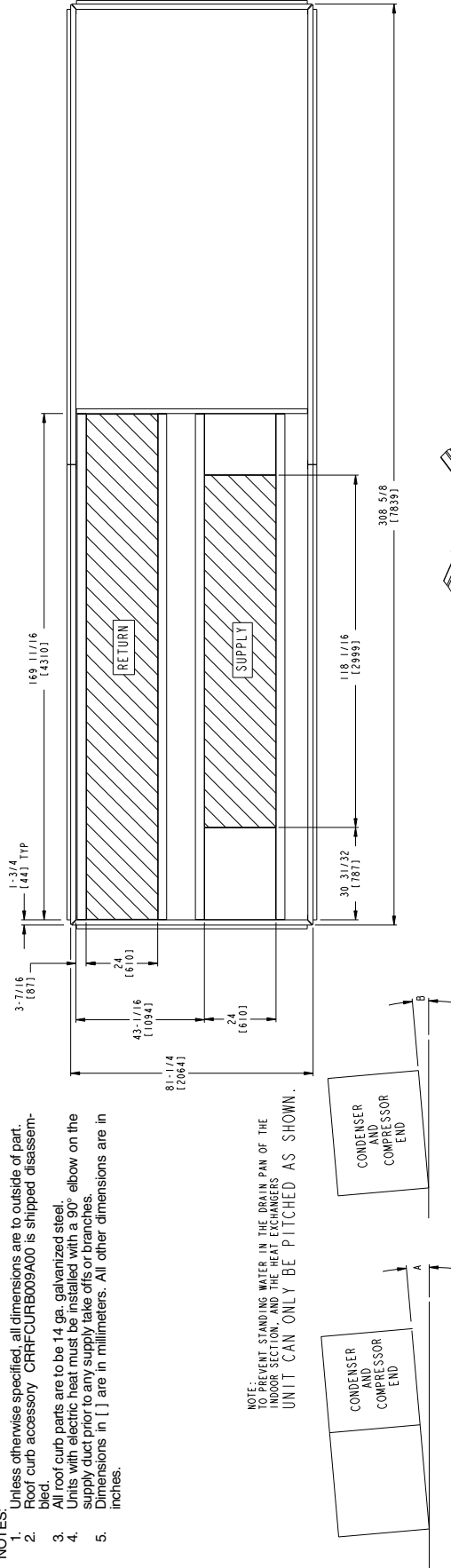

DIMENSIONS (DEGREES AND INCHES)

A		B	
DEG.	IN.	DEG.	IN.
1.0	5.43	1.38	.50
			.75
			.19

STANDARD AND MODULATING POWER EXHAUST AND BAROMETRIC RELIEF

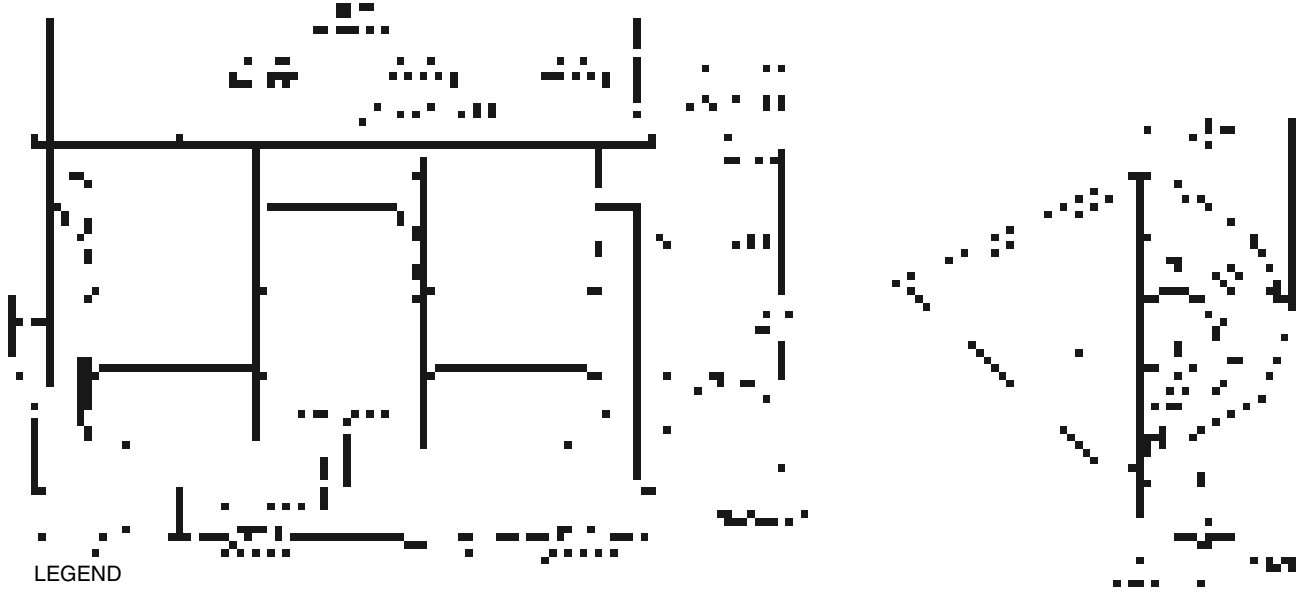

LEGEND

∅ — Diameter

NOTES:

1. Unless otherwise specified, all dimensions are to outside of part.
2. Dimensions are in inches.
3. Unit sizes 020-050 have 2 fan assemblies. Unit size 060 has 3 fan assemblies.
4. For 48/50A4,A5 units, the accessory power exhaust or barometric relief must be mounted in the field-supplied return ductwork.

HIGH CAPACITY POWER EXHAUST ACCESSORY

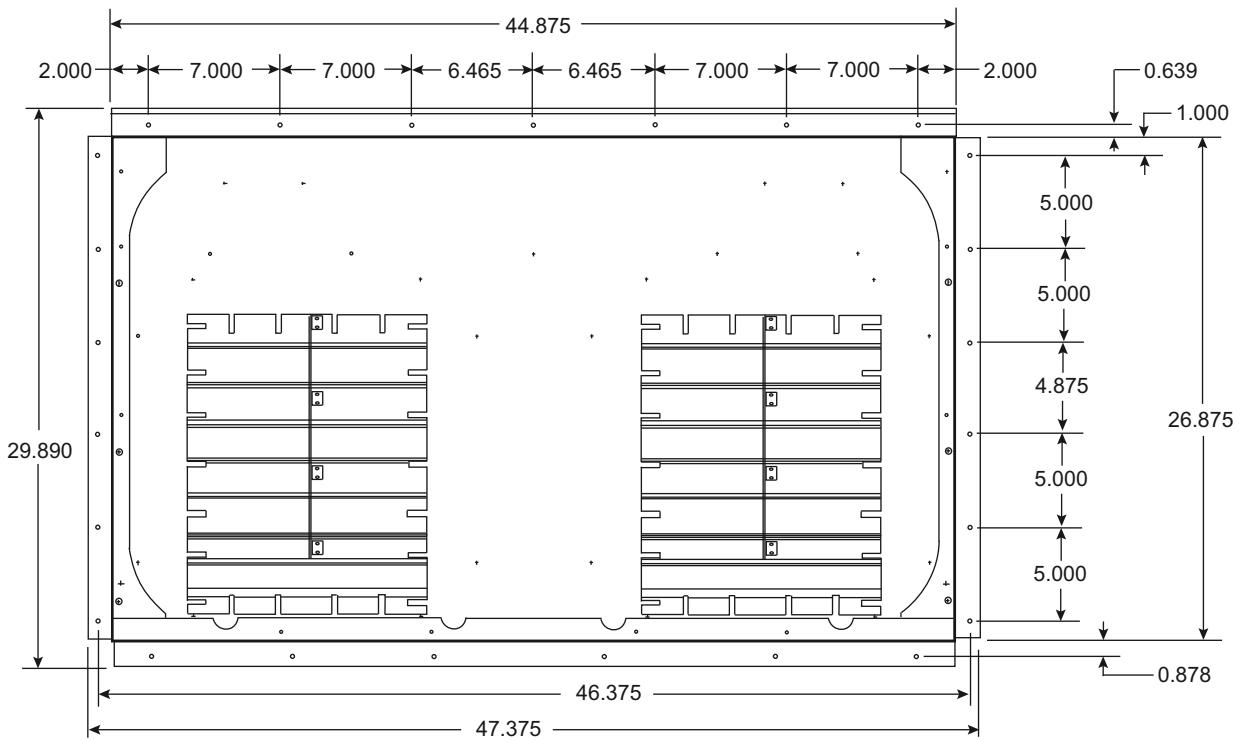

NOTE: Dimensions are in inches.

Accessory dimensions (cont)



MULTIPLE UNIT APPLICATION SPACING

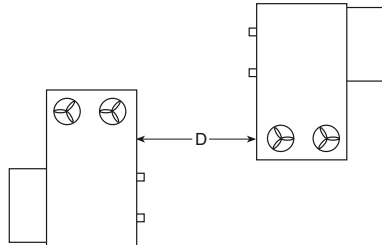
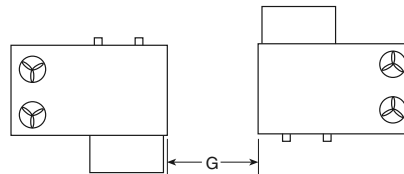
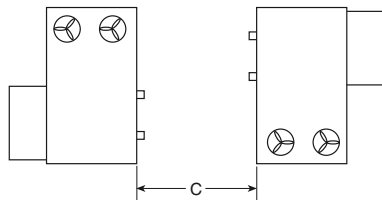
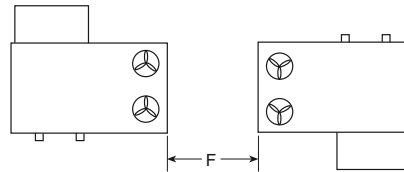
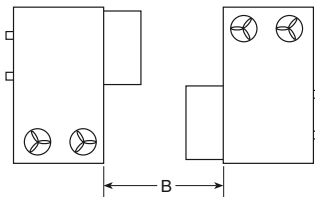
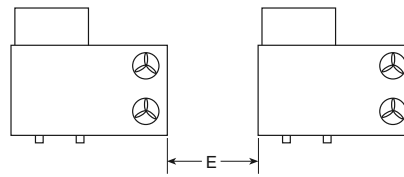
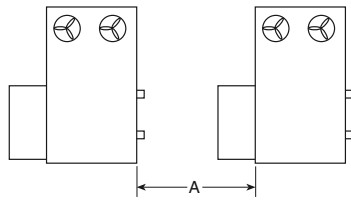

MINIMUM SPACING (FT)

UNIT	A	B	C	D	E*	F	G*	UNIT	A	B	C	D	E*	F	G*
48A2,A3,A4,A5020	15	8	4	4	10	8	10	50A2,A3,A4,A5020	8	8	4	4	10	8	10
48A2,A3,A4,A5025	15	8	4	4	10	8	10	50A2,A3,A4,A5025	8	8	4	4	10	8	10
48A2,A3,A4,A5027	15	8	4	4	10	8	10	50A2,A3,A4,A5027	8	8	4	4	10	8	10
48A2,A3,A4,A5030	15	8	4	4	10	8	10	50A2,A3,A4,A5030	8	8	4	4	10	8	10
48A2,A3,A4,A5035	15	8	4	4	10	8	10	50A2,A3,A4,A5035	8	8	4	4	10	8	10
48A2,A3,A4,A5040	15	8	4	8	10	4	10	50A2,A3,A4,A5040	8	8	4	8	10	4	10
48A2,A3,A4,A5050	15	8	4	8	10	4	10	50A2,A3,A4,A5050	8	8	4	8	10	4	10
48A2,A3,A4,A5060	15	8	4	8	15	4	15	50A2,A3,A4,A5060	8	8	4	8	15	4	15

* Required for coil removal. Can reduce to 6 ft if coil removed from top.

Selection procedure (with example)



I Determine cooling and heat requirements at design conditions.

Given:

Type Application VAV
Required Cooling Capacity (TC) 480,000 Btuh
Sensible Heat Capacity (SHC) 338,000 Btuh
Required Heating Capacity 300,000 Btuh
Design Outdoor Air db Temperature 95 F
Design Outdoor Air wb Temperature 67 F
Climate Type (as per ASHRAE 90.1 Table D) . . Dry
Indoor-Air Temperature 80 F edb, 67 F ewb
Evaporator Air Quantity 16,000 cfm
External Static Pressure 1.4 in. wg
Electrical Characteristics (V-Ph-Hz) 460-3-60
Unit Type Gas Heating Vertical Discharge

II Select the unit based on required cooling capacity.

Entering Cooling Capacity table at air condenser entering temperature of 95 F. Unit 48A3D040 at 16,000 cfm and 67 F ewb will provide the total capacity of 485,000 Btuh and a SHC of 380,000 Btuh. Calculate SHC correction, if required, using notes under cooling capacity table.

III Select heat capacity of unit to provide design condition requirements.

In the Gas Heating Capacities and Efficiencies table, note that unit 48A3D040 will provide 324,000 Btuh with an input of 400,000 Btuh.

IV Select supply fan to provide design condition requirements.

Tabulated fan performance includes 2-in. throw-away filters, wet evaporator coil, economizer, cabinet losses, and roof curb. Find fan rpm and bhp at 1.4 in. wg and 16,000 cfm on 48A3D040 Fan Performance table for vertical applications. Find that the fan speed is 1063 rpm and the power required is 19.06 bhp. Refer to the Motor Limitations table which shows the 20 hp motor is required.

V Select unit that corresponds to the power source available.

The electrical data table shows that a 460-3-60 unit is available.

VI Select the options and accessories.

As per the ASHRAE 90.1 requirements, this unit is located in a dry climate and therefore is required to have an economizer. As this is a dry climate, either differential dry bulb changeover, outdoor air changeover or differential enthalpy should be used. Outside air enthalpy cannot be used.

Select the options and model number using the options summary and model number charts in the price pages.

Note, as an alternative, a computerized selection program, *RTUBuilder*, is available for use in selecting and optimizing the unit for your application.

Performance data



Humidi-MiZer® performance data — Carrier's Humidi-MiZer adaptive dehumidification system is an all-inclusive factory-installed option that can be ordered with WeatherMaker® 48/50A2,A3,A4,A5 rooftop units.

This system expands the envelope of operation of the A Series rooftop to provide unprecedented flexibility that will meet year-round comfort conditions.

The Humidi-MiZer adaptive dehumidification system has the industry's only dual dehumidification mode setting. The WeatherMaker rooftop, coupled with the Humidi-MiZer adaptive dehumidification system, is capable of modulating between normal design cooling mode, subcooling mode, and hot gas reheat mode.

Normal design cooling mode will operate under the normal sequence of operation. Subcooling mode will operate to satisfy part load type conditions. Hot Gas Reheat mode will operate when outdoor temperatures diminish and the

need for latent capacity is required for sole humidity control. Hot Gas Reheat mode will provide neutral air for maximum dehumidification operation.

The WeatherMaker A Series next generation version of Carrier's Humidi-MiZer system includes refrigerant modulating valves that provide variable flow bypass around the condenser. This innovative feature ensures exact control of the supply-air temperature as the unit lowers the evaporator temperature to increase latent capacity.

Additionally, when the space requires dehumidification only, the Humidi-MiZer system can increase hot discharge gas bypass to the Humidi-MiZer coil in order to heat the air to the exact neutral state required—no overcooling or overheating with latent capacity similar to that provided in the full subcooling mode.

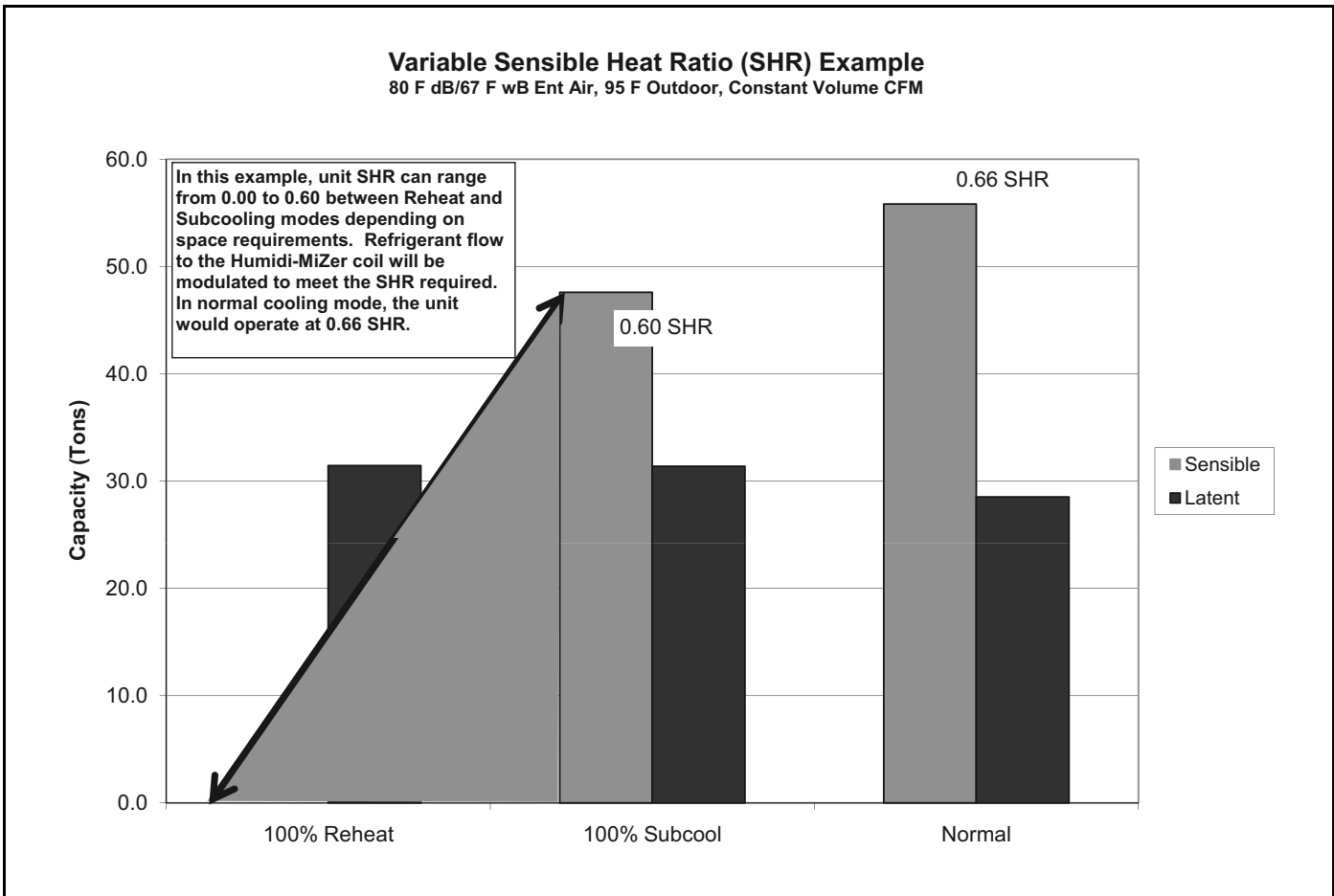

COOLING CAPACITIES

48/50A020 (20 TONS) — STANDARD MODE

Temp (F) Air Entering Condenser (Edb)		Evaporator Air Quantity — Cfm																			
		4,000					5,000					6,000					7,000				
		Evaporator Air — Ewb (F)																			
		75	72	67	62	57	75	72	67	62	57	75	72	67	62	57	75	72	67	62	57
75	TC	268	258	236	214	195	284	272	250	228	208	294	282	260	239	224	302	289	268	246	232
	SHC	109	119	141	161	179	113	128	155	180	201	116	136	168	197	224	121	144	180	213	232
	KW	14.1	14.0	13.8	13.7	13.6	14.3	14.2	14.0	13.8	13.7	14.5	14.3	14.1	13.9	13.8	14.6	14.4	14.1	13.9	13.8
	BF	0.00	0.00	0.09	0.15	0.14	0.00	0.00	0.19	0.16	0.17	0.00	0.27	0.18	0.17	0.24	0.00	0.23	0.19	0.17	0.28
85	TC	261	250	228	207	188	276	264	242	221	200	286	273	252	230	218	293	280	259	238	226
	SHC	106	115	138	158	176	110	125	152	176	194	112	133	164	193	218	118	141	176	210	226
	KW	16.0	16.0	15.8	15.7	15.5	16.2	16.1	15.9	15.8	15.6	16.4	16.2	16.0	15.8	15.8	16.5	16.3	16.1	15.9	15.8
	BF	0.02	0.00	0.21	0.15	0.13	0.00	0.14	0.18	0.15	0.17	0.00	0.24	0.18	0.16	0.26	0.15	0.22	0.18	0.17	0.30
95	TC	253	242	220	200	181	267	254	233	212	198	277	264	242	221	207	283	271	249	228	218
	SHC	102	112	134	154	172	106	122	148	172	198	109	130	161	190	207	115	137	173	206	218
	KW	18.2	18.2	18.0	17.9	17.9	18.4	18.3	18.2	18.0	17.9	18.5	18.4	18.2	18.1	18.0	18.6	18.5	18.3	18.1	18.0
	BF	0.00	0.00	0.18	0.14	0.13	0.00	0.12	0.17	0.15	0.20	0.00	0.22	0.17	0.16	0.25	0.13	0.21	0.18	0.17	0.32
105	TC	244	232	211	191	174	257	244	223	203	187	266	253	232	211	200	272	260	238	218	211
	SHC	97	109	130	150	168	101	118	144	168	187	106	126	156	185	200	112	134	168	201	211
	KW	20.7	20.6	20.6	20.7	20.8	20.8	20.8	20.6	20.8	20.8	20.9	20.8	20.7	20.6	20.7	21.0	20.9	20.7	20.6	20.6
	BF	0.00	0.00	0.17	0.13	0.13	0.00	0.25	0.16	0.14	0.19	0.00	0.20	0.16	0.15	0.28	0.28	0.20	0.17	0.17	0.35
115	TC	234	222	201	182	166	246	233	212	193	180	254	241	220	201	192	260	247	227	207	202
	SHC	93	105	126	146	162	97	114	139	164	180	103	122	152	180	192	108	129	164	195	202
	KW	23.4	23.4	23.6	23.9	24.3	23.5	23.4	23.5	23.7	24.0	23.6	23.5	23.5	23.7	23.8	23.7	23.6	23.5	23.7	23.7
	BF	0.00	0.00	0.15	0.13	0.15	0.00	0.21	0.15	0.14	0.22	0.13	0.19	0.16	0.15	0.31	0.24	0.19	0.17	0.18	0.38
120	TC	228	216	196	178	161	240	227	207	188	175	247	235	215	195	188	253	241	220	201	198
	SHC	91	103	124	143	159	95	112	137	161	175	101	120	150	178	188	106	127	162	192	198
	KW	24.9	25.1	25.4	25.7	26.3	24.9	25.0	25.2	25.5	25.8	25.0	25.0	25.1	25.4	25.6	25.1	25.0	25.1	25.3	25.4
	BF	0.00	0.12	0.14	0.12	0.15	0.00	0.20	0.15	0.14	0.24	0.29	0.18	0.16	0.15	0.32	0.23	0.18	0.17	0.18	0.39

48/50A020 (20 TONS) — STANDARD MODE (cont)

Temp (F) Air Entering Condenser (Edb)		Evaporator Air Quantity — Cfm														
		8,000					9,000					10,000				
		Evaporator Air — Ewb (F)														
		75	72	67	62	57	75	72	67	62	57	75	72	67	62	57
75	TC	308	295	274	252	243	313	299	278	257	251	317	303	282	262	259
	SHC	126	151	191	228	243	130	158	202	242	251	135	164	212	251	259
	KW	14.7	14.5	14.2	14.0	13.9	14.8	14.5	14.3	14.0	14.0	14.8	14.6	14.3	14.1	14.1
	BF	0.34	0.22	0.19	0.19	0.34	0.28	0.22	0.20	0.21	0.40	0.26	0.23	0.21	0.25	0.44
85	TC	298	286	265	243	236	302	290	269	248	244	306	294	273	253	251
	SHC	123	148	188	224	236	127	155	199	236	244	131	161	209	247	251
	KW	16.6	16.4	16.1	16.0	15.9	16.6	16.4	16.2	16.0	16.0	16.7	16.5	16.2	16.1	16.0
	BF	0.29	0.21	0.19	0.19	0.36	0.26	0.22	0.20	0.22	0.41	0.25	0.22	0.21	0.25	0.46
95	TC	288	276	255	234	228	293	280	259	239	236	296	284	262	245	243
	SHC	120	145	184	219	228	124	151	195	230	236	129	158	205	239	243
	KW	18.7	18.5	18.3	18.2	18.1	18.7	18.6	18.4	18.2	18.2	18.8	18.6	18.4	18.2	18.3
	BF	0.27	0.21	0.18	0.19	0.38	0.25	0.21	0.19	0.23	0.43	0.24	0.22	0.20	0.28	0.47
105	TC	277	265	243	223	220	281	269	248	229	227	284	272	251	235	234
	SHC	116	141	180	213	220	121	148	191	223	227	125	154	201	232	234
	KW	21.1	20.9	20.8	20.6	20.6	21.1	21.0	20.8	20.6	20.6	21.2	21.0	20.8	20.7	20.7
	BF	0.24	0.20	0.18	0.21	0.41	0.23	0.20	0.19	0.25	0.45	0.23	0.21	0.20	0.29	0.49
115	TC	264	252	231	213	211	268	256	235	219	218	271	258	238	225	224
	SHC	113	137	175	206	211	117	144	186	216	218	121	150	197	221	224
	KW	23.7	23.6	23.5	23.6	23.6	23.8	23.7	23.5	23.5	23.6	23.8	23.7	23.5	23.5	23.5
	BF	0.22	0.19	0.18	0.22	0.43	0.22	0.20	0.19	0.26	0.48	0.22	0.21	0.20	0.32	0.52
120	TC	257	245	225	207	206	261	248	229	215	213	263	251	232	219	219
	SHC	110	134	173	202	206	115	141	184	215	213	119	148	194	219	219
	KW	25.1	25.1	25.1	25.2	25.3	25.2	25.1	25.0	25.2	25.2	25.3	25.1	25.0	25.1	25.1
	BF	0.22	0.19	0.18	0.23	0.44	0.22	0.20	0.19	0.29	0.49	0.22	0.21	0.20	0.32	0.53

See legend on page 57.

Performance data (cont)



COOLING CAPACITIES (cont)

48/50A020 (20 TONS) — SUBCOOLING MODE

Temp (F) Air Entering Condenser (Edb)		Evaporator Air Quantity – SCFM																			
		4,000					5,000					6,000					7,000				
		Evaporator Air Ewb (F)																			
		75	72	67	62	57	75	72	67	62	57	75	72	67	62	57	75	72	67	62	57
75	TC	265	249	223	204	184	285	269	239	220	199	293	277	251	232	212	303	286	260	236	222
	SHC	96	109	126	147	166	107	121	140	168	191	109	126	153	186	209	115	134	166	197	222
	kW	14.0	13.8	13.6	13.5	13.4	14.1	14.0	13.7	13.6	13.5	14.2	14.0	13.8	13.7	13.6	14.3	14.1	13.9	13.7	13.6
	BF	0.00	0.02	0.09	0.10	0.10	0.00	0.08	0.11	0.12	0.12	0.03	0.11	0.13	0.14	0.19	0.08	0.14	0.15	0.15	0.25
85	TC	249	234	201	193	173	265	250	219	207	187	277	262	240	214	199	286	270	248	226	212
	SHC	83	96	106	139	157	91	105	123	157	179	97	114	145	170	197	102	122	157	191	212
	kW	15.5	15.4	15.1	15.1	15.0	15.7	15.5	15.2	15.2	15.1	15.8	15.6	15.4	15.2	15.1	15.9	15.7	15.5	15.3	15.3
	BF	0.00	0.03	0.09	0.10	0.10	0.01	0.09	0.12	0.12	0.14	0.05	0.12	0.13	0.14	0.20	0.10	0.14	0.15	0.15	0.26
95	TC	235	222	201	177	162	251	237	214	192	177	262	247	223	204	188	270	255	231	210	199
	SHC	72	87	108	125	148	80	95	121	145	170	86	103	132	163	188	90	110	144	179	199
	kW	17.3	17.2	17.0	16.8	16.7	17.5	17.3	17.1	16.9	16.9	17.6	17.4	17.2	17.0	17.0	17.7	17.5	17.3	17.1	17.0
	BF	0.00	0.05	0.10	0.10	0.10	0.02	0.10	0.12	0.12	0.16	0.07	0.12	0.13	0.14	0.20	0.10	0.14	0.15	0.16	0.28
105	TC	221	207	186	167	150	226	220	199	176	163	246	231	209	189	176	214	238	215	196	181
	SHC	61	75	97	118	138	58	82	109	132	158	72	90	121	151	176	38	97	131	168	181
	kW	19.3	19.2	19.0	18.9	18.8	19.3	19.3	19.2	18.9	18.9	19.6	19.4	19.2	19.1	19.0	19.0	19.5	19.3	19.1	19.0
	BF	0.00	0.07	0.10	0.10	0.11	0.03	0.10	0.12	0.12	0.17	0.08	0.12	0.14	0.14	0.22	0.11	0.14	0.15	0.16	0.30
115	TC	205	191	170	150	136	219	205	184	165	151	199	215	192	173	157	222	200	198	178	168
	SHC	50	63	84	104	126	55	71	97	124	147	31	78	108	140	157	50	63	119	153	168
	kW	21.6	21.5	21.3	21.1	21.1	21.7	21.6	21.4	21.3	21.2	21.4	21.7	21.5	21.4	21.2	21.6	21.4	21.5	21.4	21.3
	BF	0.00	0.08	0.10	0.10	0.11	0.04	0.11	0.12	0.12	0.18	0.09	0.13	0.14	0.14	0.24	0.12	0.14	0.15	0.16	0.32

48/50A020 (20 TONS) — SUBCOOLING MODE (cont)

Temp (F) Air Entering Condenser (Edb)		Evaporator Air Quantity – SCFM														
		8,000					9,000					10,000				
		Evaporator Air Ewb (F)														
		75	72	67	62	57	75	72	67	62	57	75	72	67	62	57
75	TC	317	299	267	242	235	317	300	273	248	243	322	305	280	258	251
	SHC	126	147	177	213	235	126	149	188	227	243	130	156	202	246	251
	kW	14.4	14.3	13.9	13.7	13.7	14.4	14.2	14.0	13.8	13.8	14.4	14.3	14.1	13.9	13.8
	BF	0.12	0.16	0.17	0.17	0.32	0.14	0.18	0.18	0.19	0.37	0.17	0.19	0.20	0.21	0.42
85	TC	294	277	252	232	222	299	284	260	238	231	307	290	264	238	234
	SHC	108	129	166	205	222	112	138	180	220	231	120	146	190	225	234
	kW	15.9	15.8	15.5	15.4	15.3	16.0	15.8	15.6	15.5	15.4	16.1	15.9	15.7	15.4	15.4
	BF	0.13	0.16	0.17	0.17	0.33	0.15	0.18	0.18	0.20	0.38	0.17	0.19	0.20	0.24	0.43
95	TC	277	262	236	217	209	282	267	241	221	216	287	270	246	226	223
	SHC	95	118	153	194	209	99	124	165	206	216	104	130	176	214	223
	kW	17.7	17.6	17.3	17.2	17.1	17.8	17.6	17.4	17.2	17.2	17.8	17.7	17.4	17.3	17.2
	BF	0.13	0.16	0.17	0.18	0.34	0.15	0.18	0.18	0.20	0.40	0.17	0.19	0.20	0.25	0.44
105	TC	248	224	221	198	195	230	240	225	186	199	256	217	229	213	207
	SHC	70	84	142	178	195	51	101	153	171	199	77	83	163	203	207
	kW	19.6	19.3	19.3	19.1	19.2	19.3	19.5	19.4	18.9	19.2	19.7	19.2	19.4	19.3	19.2
	BF	0.14	0.16	0.17	0.18	0.36	0.16	0.18	0.18	0.22	0.41	0.18	0.19	0.20	0.26	0.45
115	TC	186	182	204	185	178	237	185	208	189	186	205	187	195	195	192
	SHC	14	46	130	166	178	63	51	140	175	186	31	56	133	187	192
	kW	21.1	21.1	21.6	21.5	21.4	21.7	21.2	21.6	21.5	21.5	21.3	21.2	21.4	21.5	21.5
	BF	0.14	0.16	0.17	0.20	0.38	0.16	0.18	0.18	0.24	0.43	0.18	0.19	0.19	0.27	0.47

See legend on page 57.

COOLING CAPACITIES (cont)

50A020 (20 TONS) — HOT GAS REHEAT MODE

Temp (F) Air Entering Condenser (Edb)		Air Entering Evaporator — Ewb (F)													
		75 Dry Bulb							75 Dry Bulb						
		62.5 Wet Bulb (50% RH)							65.3 Wet Bulb (60% RH)						
		Air Entering Evaporator — SCFM													
		4,000	5,000	6,000	7,000	8,000	9,000	10,000	4,000	5,000	6,000	7,000	8,000	9,000	10,000
40	TC	78	87	94	99	104	107	109	83	93	101	106	111	114	117
	SHC	0	8	16	25	33	41	49	-17	-11	-5	1	6	12	18
	KW	15.8	15.1	14.8	14.5	14.4	14.3	14.2	16.6	15.8	15.4	15.1	14.9	14.8	14.7
	BF	0.07	0.09	0.11	0.13	0.14	0.15	0.17	0.05	0.08	0.10	0.12	0.14	0.15	0.17
50	TC	72	81	87	92	95	98	100	76	86	92	97	101	104	107
	SHC	-4	4	12	21	29	36	44	-21	-15	-10	-4	2	7	13
	KW	16.4	15.7	15.3	15.0	14.9	14.8	14.7	17.1	16.3	15.9	15.6	15.4	15.3	15.2
	BF	0.07	0.09	0.11	0.13	0.14	0.15	0.17	0.06	0.08	0.10	0.12	0.14	0.15	0.17
60	TC	66	75	81	85	88	91	93	71	80	87	91	94	97	99
	SHC	-8	1	9	17	25	33	40	-24	-19	-13	-7	-2	3	9
	KW	17.0	16.2	15.8	15.5	15.4	15.3	15.2	17.7	16.9	16.4	16.1	15.9	15.8	15.7
	BF	0.07	0.09	0.11	0.13	0.14	0.15	0.17	0.06	0.09	0.11	0.12	0.14	0.15	0.17
70	TC	61	69	75	79	82	85	86	65	74	80	85	88	90	92
	SHC	-11	-3	5	14	22	29	37	-28	-22	-17	-11	-5	0	6
	KW	17.6	16.8	16.4	16.1	16.0	15.8	15.8	18.4	17.5	17.0	16.7	16.5	16.3	16.2
	BF	0.07	0.09	0.11	0.13	0.14	0.15	0.17	0.06	0.09	0.11	0.12	0.14	0.15	0.17
75	TC	58	67	72	76	79	81	83	63	71	77	81	84	87	89
	SHC	-13	-4	4	12	20	28	35	-29	-24	-18	-13	-7	-2	4
	KW	17.9	17.2	16.7	16.5	16.3	16.2	16.1	18.7	17.8	17.3	17.0	16.8	16.7	16.6
	BF	0.07	0.09	0.11	0.13	0.14	0.15	0.17	0.06	0.09	0.11	0.12	0.14	0.15	0.17
80	TC	56	64	70	73	76	78	80	60	69	74	78	81	84	85
	SHC	-14	-6	2	10	18	26	34	-31	-25	-20	-14	-9	-3	2
	KW	18.3	17.5	17.1	16.8	16.6	16.5	16.4	19.1	18.2	17.6	17.3	17.1	17.0	16.9
	BF	0.07	0.09	0.11	0.13	0.14	0.15	0.17	0.07	0.09	0.11	0.12	0.14	0.15	0.17

50A020 (20 TONS) — HOT GAS REHEAT MODE (cont)

Temp (F) Air Entering Condenser (Edb)		Air Entering Evaporator — Ewb (F)													
		75 Dry Bulb							75 Dry Bulb						
		68.0 Wet Bulb (70% RH)							70.5 Wet Bulb (80% RH)						
		Air Entering Evaporator — SCFM													
		4,000	5,000	6,000	7,000	8,000	9,000	10,000	4,000	5,000	6,000	7,000	8,000	9,000	10,000
40	TC	87	99	107	113	117	121	123	92	104	112	119	123	127	130
	SHC	-34	-30	-27	-23	-20	-16	-13	-50	-49	-47	-46	-44	-43	-41
	KW	17.4	16.5	16.0	15.6	15.4	15.3	15.2	18.2	17.1	16.5	16.2	15.9	15.8	15.6
	BF	0.02	0.04	0.08	0.11	0.12	0.14	0.16	0.00	0.00	0.03	0.05	0.09	0.11	0.13
50	TC	81	91	98	104	108	111	114	85	96	104	110	114	117	120
	SHC	-38	-34	-31	-28	-24	-21	-17	-54	-53	-51	-50	-49	-47	-46
	KW	17.9	17.0	16.4	16.1	15.9	15.8	15.6	18.7	17.6	17.0	16.6	16.4	16.2	16.1
	BF	0.02	0.06	0.09	0.11	0.13	0.14	0.16	0.00	0.00	0.03	0.06	0.09	0.12	0.14
60	TC	75	85	92	96	100	103	105	79	90	96	101	105	108	111
	SHC	-41	-38	-35	-31	-28	-25	-22	-57	-56	-55	-54	-53	-51	-50
	KW	18.5	17.5	17.0	16.6	16.4	16.3	16.2	19.3	18.2	17.5	17.2	16.9	16.7	16.6
	BF	0.02	0.06	0.09	0.11	0.13	0.15	0.16	0.00	0.01	0.03	0.07	0.10	0.12	0.14
70	TC	70	79	85	90	93	95	97	74	83	90	95	98	101	103
	SHC	-44	-41	-38	-35	-32	-29	-25	-60	-59	-58	-57	-56	-55	-54
	KW	19.1	18.1	17.6	17.2	17.0	16.8	16.7	19.9	18.8	18.1	17.7	17.5	17.3	17.2
	BF	0.03	0.07	0.09	0.11	0.13	0.15	0.16	0.00	0.01	0.04	0.08	0.10	0.12	0.14
75	TC	67	76	82	86	90	92	94	71	80	87	91	95	97	99
	SHC	-46	-43	-40	-37	-33	-30	-27	-62	-61	-60	-59	-58	-57	-55
	KW	19.5	18.4	17.9	17.5	17.3	17.1	17.0	20.2	19.1	18.4	18.1	17.8	17.6	17.5
	BF	0.03	0.07	0.09	0.11	0.13	0.15	0.16	0.00	0.01	0.04	0.08	0.10	0.13	0.14
80	TC	64	73	79	83	86	89	91	68	77	84	88	91	94	96
	SHC	-48	-44	-41	-38	-35	-32	-28	-64	-62	-61	-61	-60	-58	-57
	KW	19.8	18.8	18.2	17.9	17.6	17.5	17.4	20.6	19.4	18.8	18.4	18.1	17.9	17.8
	BF	0.03	0.07	0.09	0.11	0.13	0.15	0.16	0.00	0.01	0.05	0.08	0.11	0.13	0.15

See legend on page 57.

Performance data (cont)



COOLING CAPACITIES (cont)

48/50A025 (25 TONS) — STANDARD MODE

Temp (F) Air Entering Condenser (Edb)		Evaporator Air Quantity — Cfm																			
		5,000					6,250					7,500					8,750				
		Evaporator Air — Ewb (F)																			
		75	72	67	62	57	75	72	67	62	57	75	72	67	62	57	75	72	67	62	57
75	TC	318	305	281	260	239	335	320	296	274	253	347	331	307	284	268	354	339	315	292	280
	SHC	128	142	173	201	226	133	154	190	224	251	138	165	205	242	268	145	175	220	264	280
	KW	18.7	18.4	17.9	17.6	17.2	19.0	18.7	18.2	17.8	17.4	19.3	18.9	18.4	18.0	17.7	19.4	19.1	18.6	18.1	17.9
	BF	0.00	0.00	0.18	0.13	0.11	0.00	0.11	0.16	0.13	0.16	0.00	0.22	0.17	0.15	0.24	0.13	0.21	0.17	0.16	0.32
85	TC	308	295	274	253	232	324	309	287	266	248	334	319	297	275	261	341	327	305	283	273
	SHC	124	139	170	197	222	127	151	186	220	248	135	161	202	242	261	141	170	216	260	273
	KW	20.8	20.5	20.1	19.8	19.5	21.1	20.8	20.3	20.0	19.6	21.3	21.0	20.5	20.2	19.9	21.5	21.2	20.7	20.3	20.1
	BF	0.00	0.00	0.17	0.12	0.12	0.00	0.10	0.16	0.13	0.18	0.00	0.21	0.16	0.15	0.26	0.11	0.20	0.17	0.16	0.33
95	TC	298	286	265	244	224	312	300	278	257	241	321	309	288	266	254	328	316	295	273	265
	SHC	119	136	166	193	217	124	147	182	216	241	131	157	198	236	254	137	166	212	255	265
	KW	23.1	22.8	22.5	22.3	22.0	23.4	23.1	22.8	22.5	22.2	23.6	23.4	23.0	22.6	22.4	23.8	23.5	23.1	22.7	22.6
	BF	0.00	0.00	0.15	0.12	0.12	0.00	0.24	0.15	0.13	0.20	0.13	0.20	0.16	0.15	0.28	0.26	0.19	0.17	0.17	0.35
105	TC	289	277	256	235	214	302	290	268	247	231	311	298	277	255	245	318	304	283	262	257
	SHC	116	133	162	188	208	121	144	178	211	228	128	153	193	231	245	134	163	208	249	257
	KW	25.7	25.6	25.3	25.1	24.9	26.0	25.9	25.6	25.3	25.0	26.2	26.0	25.8	25.5	25.3	26.4	26.2	25.9	25.5	25.4
	BF	0.00	0.00	0.14	0.11	0.12	0.00	0.21	0.15	0.13	0.22	0.11	0.18	0.15	0.15	0.30	0.24	0.18	0.17	0.17	0.37
115	TC	278	266	245	224	207	289	278	256	236	223	298	285	264	243	236	305	290	270	250	247
	SHC	111	128	157	183	203	117	139	173	205	223	124	149	188	225	236	130	158	203	242	247
	KW	28.7	28.6	28.5	28.6	28.3	29.0	28.9	28.7	28.7	28.5	29.2	29.1	28.9	28.7	28.5	29.4	29.1	28.9	28.7	28.6
	BF	0.00	0.09	0.13	0.11	0.16	0.00	0.19	0.14	0.13	0.24	0.26	0.17	0.15	0.15	0.33	0.22	0.17	0.16	0.18	0.40

48/50A025 (25 TONS) — STANDARD MODE (cont)

Temp (F) Air Entering Condenser (Edb)		Evaporator Air Quantity — Cfm														
		10,000					11,250					12,500				
		Evaporator Air — Ewb (F)														
		75	72	67	62	57	75	72	67	62	57	75	72	67	62	57
75	TC	361	346	321	297	291	367	351	326	303	300	372	355	330	309	307
	SHC	152	184	234	281	291	158	192	248	295	300	163	201	261	305	307
	KW	19.6	19.2	18.7	18.2	18.1	19.7	19.3	18.8	18.4	18.3	19.8	19.4	18.9	18.5	18.4
	BF	0.28	0.20	0.18	0.19	0.38	0.25	0.21	0.19	0.21	0.43	0.25	0.22	0.20	0.26	0.48
85	TC	348	332	310	288	283	353	337	315	294	291	357	341	318	299	299
	SHC	148	179	230	275	283	153	188	244	288	291	159	197	257	296	299
	KW	21.6	21.3	20.8	20.4	20.3	21.8	21.4	20.9	20.5	20.4	21.8	21.5	21.0	20.6	20.6
	BF	0.25	0.20	0.18	0.19	0.40	0.24	0.21	0.19	0.23	0.45	0.24	0.21	0.20	0.26	0.49
95	TC	335	321	300	278	275	340	325	304	284	283	343	330	308	290	290
	SHC	144	175	226	270	275	150	184	240	281	283	155	192	253	290	290
	KW	23.9	23.6	23.2	22.8	22.7	24.0	23.7	23.3	22.9	22.9	24.1	23.8	23.4	23.0	23.0
	BF	0.24	0.19	0.18	0.19	0.41	0.23	0.19	0.19	0.24	0.46	0.23	0.21	0.20	0.29	0.50
105	TC	323	310	288	268	266	328	314	292	275	274	331	318	296	280	280
	SHC	140	172	222	260	266	146	180	235	268	274	151	188	248	280	280
	KW	26.6	26.3	26.0	25.5	25.5	26.7	26.4	26.0	25.6	25.7	26.8	26.5	26.1	25.8	25.8
	BF	0.22	0.18	0.18	0.22	0.43	0.22	0.20	0.19	0.27	0.48	0.22	0.21	0.20	0.31	0.52
115	TC	309	297	275	256	255	313	300	278	263	263	317	303	281	269	269
	SHC	136	167	217	254	255	142	175	230	261	263	147	184	243	269	269
	KW	29.6	29.4	29.0	28.7	28.7	29.7	29.4	29.1	28.8	28.8	29.8	29.5	29.1	28.9	28.9
	BF	0.21	0.19	0.18	0.23	0.46	0.21	0.20	0.19	0.30	0.50	0.21	0.21	0.20	0.34	0.54

See legend on page 57.

COOLING CAPACITIES (cont)

48/50A025 (25 TONS) — SUBCOOLING MODE

Temp (F) Air Entering Condenser (Edb)		Evaporator Air Quantity – SCFM																			
		5,000					6,250					7,500					8,750				
		Evaporator Air Ewb (F)																			
		75	72	67	62	57	75	72	67	62	57	75	72	67	62	57	75	72	67	62	57
75	TC	331	298	284	253	233	338	321	292	276	251	359	334	317	290	267	367	358	316	288	271
	SHC	118	121	162	183	212	115	136	170	213	242	130	147	198	236	267	134	170	202	246	271
	kW	18.0	17.2	17.2	16.5	16.4	17.9	17.6	17.1	17.0	16.6	18.2	17.8	17.7	17.3	17.0	18.2	18.4	17.5	17.0	16.8
	BF	0.00	0.01	0.05	0.06	0.07	0.00	0.05	0.08	0.08	0.10	0.02	0.08	0.09	0.10	0.16	0.06	0.10	0.11	0.12	0.24
85	TC	314	294	265	231	222	330	314	283	261	229	332	315	288	274	252	356	337	305	272	260
	SHC	105	120	145	163	203	111	134	163	200	220	107	132	173	223	252	128	154	195	233	260
	kW	19.9	19.4	18.8	18.2	18.4	20.1	19.9	19.1	18.9	18.1	19.9	19.6	19.2	19.2	18.8	20.7	20.3	19.5	18.9	18.6
	BF	0.00	0.02	0.06	0.06	0.07	0.00	0.05	0.08	0.08	0.12	0.03	0.08	0.09	0.10	0.18	0.07	0.10	0.11	0.12	0.26
95	TC	285	281	255	232	208	312	297	265	248	226	325	309	271	258	239	336	318	280	256	254
	SHC	79	110	138	166	190	98	120	149	189	218	105	129	159	211	239	112	139	174	219	254
	kW	21.5	21.7	21.2	20.8	20.3	22.4	22.0	21.2	21.1	20.8	22.6	22.2	21.3	21.2	20.9	22.9	22.4	21.4	21.0	21.2
	BF	0.00	0.02	0.06	0.06	0.07	0.01	0.06	0.08	0.08	0.13	0.04	0.08	0.09	0.10	0.19	0.07	0.10	0.11	0.12	0.27
105	TC	267	264	229	217	196	294	279	253	231	212	293	278	254	228	222	309	293	267	235	236
	SHC	66	97	115	153	180	83	106	140	176	205	76	102	145	183	222	93	120	166	201	236
	kW	23.9	24.1	23.1	23.1	22.8	24.8	24.5	23.9	23.4	23.2	24.4	24.1	23.6	23.1	23.4	25.1	24.6	24.0	23.2	23.7
	BF	0.00	0.02	0.06	0.06	0.07	0.01	0.06	0.08	0.08	0.15	0.04	0.08	0.09	0.12	0.22	0.09	0.12	0.13	0.15	0.30
115	TC	253	245	221	189	170	259	252	223	201	184	268	255	244	211	196	276	262	239	218	220
	SHC	58	83	112	129	155	55	85	114	149	178	60	86	140	169	196	64	93	141	187	220
	kW	26.6	26.9	26.4	25.2	24.7	26.7	26.7	25.9	25.5	25.1	26.9	26.6	26.7	25.7	25.3	27.1	26.8	26.3	25.8	26.3
	BF	0.00	0.04	0.07	0.08	0.11	0.02	0.08	0.10	0.10	0.18	0.06	0.10	0.12	0.12	0.24	0.10	0.12	0.13	0.15	0.32

48/50A025 (25 TONS) — SUBCOOLING MODE (cont)

Temp (F) Air Entering Condenser (Edb)		Evaporator Air Quantity – SCFM														
		10,000					11,250					12,500				
		Evaporator Air Ewb (F)														
		75	72	67	62	57	75	72	67	62	57	75	72	67	62	57
75	TC	371	353	336	306	295	378	372	342	313	306	383	365	348	309	316
	SHC	136	166	229	276	295	142	189	244	294	306	148	184	258	299	316
	kW	18.4	18.1	18.0	17.6	17.4	18.4	18.6	18.1	17.7	17.6	18.6	18.3	18.2	17.4	17.7
	BF	0.09	0.12	0.13	0.14	0.31	0.12	0.14	0.14	0.16	0.37	0.14	0.15	0.16	0.20	0.42
85	TC	349	332	305	279	269	355	338	311	285	289	374	343	316	303	288
	SHC	119	151	203	252	269	125	159	217	268	289	144	168	230	294	288
	kW	20.2	19.9	19.5	19.0	18.8	20.3	20.1	19.6	19.1	19.4	21.0	20.1	19.7	19.7	19.2
	BF	0.10	0.12	0.13	0.14	0.33	0.12	0.14	0.14	0.17	0.38	0.14	0.15	0.15	0.22	0.43
95	TC	327	312	286	262	254	333	317	291	268	263	352	333	304	274	271
	SHC	103	135	188	237	254	108	143	202	252	263	128	163	223	265	271
	kW	22.2	22.0	21.6	21.1	20.9	22.5	22.2	21.7	21.2	21.1	23.1	22.7	22.0	21.3	21.3
	BF	0.10	0.12	0.13	0.15	0.34	0.12	0.14	0.14	0.19	0.39	0.14	0.15	0.15	0.23	0.44
105	TC	315	290	263	254	246	323	307	269	260	254	325	296	273	253	251
	SHC	98	119	169	231	246	106	139	182	244	254	109	132	195	244	251
	kW	25.2	24.4	23.8	24.0	23.8	25.5	25.1	23.9	24.1	24.0	25.5	24.5	24.0	23.6	23.5
	BF	0.12	0.14	0.15	0.18	0.36	0.14	0.16	0.17	0.23	0.42	0.16	0.18	0.18	0.26	0.46
115	TC	281	281	257	237	230	286	285	249	230	238	290	289	266	235	233
	SHC	69	114	167	214	230	73	121	167	215	238	77	129	192	227	233
	kW	27.2	27.5	27.0	26.7	26.5	27.4	27.6	26.5	26.1	26.6	27.4	27.7	27.2	26.2	26.1
	BF	0.12	0.14	0.15	0.20	0.38	0.15	0.16	0.17	0.24	0.43	0.17	0.18	0.18	0.27	0.47

See legend on page 57.

Performance data (cont)



COOLING CAPACITIES (cont)

50A025 (25 TONS) — HOT GAS REHEAT MODE

Temp (F) Air Entering Condenser (Edb)		Air Entering Evaporator — Ewb (F)													
		75 Dry Bulb							75 Dry Bulb						
		62.5 Wet Bulb (50% RH)							65.3 Wet Bulb (60% RH)						
		Air Entering Evaporator — SCFM													
		5,000	6,250	7,500	8,750	10,000	11,250	12,500	5,000	6,250	7,500	8,750	10,000	11,250	12,500
40	TC	75	84	92	97	101	105	107	79	90	98	104	108	112	115
	SHC	-13	-3	7	18	29	39	50	-35	-28	-21	-14	-6	1	9
	kW	18.5	17.6	17.0	16.7	16.4	16.2	16.1	19.4	18.4	17.8	17.4	17.1	16.9	16.7
	BF	0.04	0.06	0.08	0.09	0.11	0.12	0.13	0.03	0.05	0.07	0.09	0.10	0.12	0.13
50	TC	69	78	85	90	94	96	99	73	83	90	95	99	103	105
	SHC	-17	-7	3	14	25	35	45	-39	-32	-26	-18	-11	-4	4
	kW	19.0	18.1	17.5	17.1	16.9	16.7	16.5	20.0	18.9	18.3	17.8	17.5	17.3	17.1
	BF	0.04	0.06	0.08	0.09	0.11	0.12	0.13	0.03	0.06	0.07	0.09	0.11	0.12	0.13
60	TC	63	72	78	82	85	88	90	67	76	83	87	91	94	96
	SHC	-20	-10	0	10	20	31	41	-43	-36	-30	-23	-15	-8	0
	kW	19.5	18.6	18.0	17.6	17.4	17.2	17.0	20.5	19.4	18.8	18.3	18.0	17.8	17.6
	BF	0.04	0.06	0.08	0.09	0.11	0.12	0.13	0.04	0.06	0.07	0.09	0.11	0.12	0.13
70	TC	58	66	72	76	79	81	82	61	70	76	80	83	86	88
	SHC	-24	-14	-4	6	17	27	37	-46	-40	-33	-26	-19	-12	-4
	kW	20.2	19.2	18.6	18.2	17.9	17.7	17.6	21.1	20.0	19.3	18.9	18.6	18.3	18.2
	BF	0.04	0.06	0.08	0.09	0.11	0.12	0.13	0.04	0.06	0.07	0.09	0.10	0.12	0.13
75	TC	55	63	69	73	76	78	79	58	67	73	77	80	82	84
	SHC	-26	-16	-6	5	15	25	35	-48	-42	-35	-28	-21	-14	-6
	kW	20.5	19.5	18.9	18.5	18.2	18.0	17.8	21.5	20.3	19.6	19.2	18.9	18.6	18.4
	BF	0.04	0.06	0.08	0.09	0.11	0.12	0.13	0.04	0.06	0.07	0.09	0.10	0.12	0.13
80	TC	52	60	66	70	72	74	76	56	64	70	74	77	79	81
	SHC	-27	-18	-8	3	13	24	34	-49	-43	-37	-30	-23	-15	-8
	kW	20.8	19.8	19.2	18.8	18.5	18.3	18.1	21.8	20.7	20.0	19.5	19.2	18.9	18.7
	BF	0.05	0.06	0.08	0.09	0.10	0.12	0.13	0.04	0.06	0.07	0.09	0.10	0.12	0.13

50A025 (25 TONS) — HOT GAS REHEAT MODE (cont)

Temp (F) Air Entering Condenser (Edb)		Air Entering Evaporator — Ewb (F)													
		75 Dry Bulb							75 Dry Bulb						
		68.0 Wet Bulb (70% RH)							70.5 Wet Bulb (80% RH)						
		Air Entering Evaporator — SCFM													
		5,000	6,250	7,500	8,750	10,000	11,250	12,500	5,000	6,250	7,500	8,750	10,000	11,250	12,500
40	TC	83	95	104	110	115	118	121	88	100	109	116	121	124	128
	SHC	-57	-53	-49	-46	-41	-37	-33	-78	-77	-76	-75	-74	-73	-71
	kW	20.5	19.3	18.6	18.1	17.7	17.5	17.3	21.6	20.2	19.3	18.8	18.4	18.1	17.9
	BF	0.02	0.03	0.06	0.08	0.10	0.12	0.13	0.00	0.00	0.02	0.04	0.07	0.09	0.12
50	TC	77	88	95	101	105	109	111	80	92	100	106	111	115	118
	SHC	-61	-57	-54	-50	-46	-42	-37	-82	-81	-81	-80	-79	-77	-76
	kW	21.0	19.8	19.0	18.5	18.2	17.9	17.8	22.1	20.7	19.8	19.2	18.9	18.6	18.3
	BF	0.02	0.04	0.06	0.08	0.10	0.12	0.13	0.00	0.00	0.02	0.05	0.07	0.10	0.12
60	TC	71	80	87	93	97	100	102	74	85	92	98	102	105	108
	SHC	-64	-61	-58	-54	-50	-46	-41	-86	-85	-85	-84	-83	-81	-80
	kW	21.6	20.3	19.6	19.0	18.7	18.4	18.2	22.7	21.2	20.3	19.7	19.3	19.0	18.8
	BF	0.02	0.04	0.06	0.08	0.10	0.12	0.13	0.00	0.00	0.02	0.05	0.08	0.10	0.12
70	TC	65	74	80	85	89	91	94	68	78	85	90	94	97	99
	SHC	-68	-65	-62	-58	-54	-50	-45	-89	-89	-88	-88	-87	-85	-84
	kW	22.2	20.9	20.1	19.6	19.2	19.0	18.8	23.3	21.8	20.9	20.3	19.9	19.6	19.3
	BF	0.02	0.04	0.06	0.08	0.10	0.12	0.13	0.00	0.00	0.03	0.06	0.08	0.10	0.12
75	TC	62	71	77	82	85	88	90	65	75	81	86	90	93	95
	SHC	-70	-67	-63	-60	-56	-52	-47	-91	-90	-90	-90	-89	-87	-86
	kW	22.5	21.2	20.4	19.9	19.5	19.3	19.0	23.6	22.1	21.2	20.6	20.2	19.9	19.6
	BF	0.02	0.04	0.07	0.08	0.10	0.12	0.13	0.00	0.01	0.03	0.06	0.08	0.10	0.12
80	TC	59	68	74	78	81	84	86	62	72	78	82	86	89	91
	SHC	-71	-68	-65	-62	-58	-54	-49	-92	-92	-92	-91	-91	-89	-88
	kW	22.8	21.5	20.7	20.2	19.8	19.6	19.4	23.9	22.4	21.5	20.9	20.5	20.2	19.9
	BF	0.02	0.04	0.07	0.08	0.10	0.12	0.13	0.00	0.01	0.03	0.06	0.08	0.10	0.12

See legend on page 57.

COOLING CAPACITIES (cont)

48/50A027 (27 TONS) — STANDARD MODE

Temp (F) Air Entering Condenser (Edb)		Evaporator Air Quantity — Cfm																			
		5,500					6,875					8,250					9,625				
		Evaporator Air — Ewb (F)																			
		75	72	67	62	57	75	72	67	62	57	75	72	67	62	57	75	72	67	62	57
75	TC	339	324	297	273	251	356	340	312	288	268	368	351	323	298	283	377	359	331	305	296
	SHC	138	154	186	215	242	145	168	204	240	265	153	180	222	263	283	161	190	238	284	296
	KW	19.0	18.7	18.3	17.9	17.6	19.4	19.0	18.5	18.1	17.8	19.6	19.3	18.7	18.3	18.1	19.8	19.4	18.9	18.5	18.3
	BF	0.00	0.00	0.15	0.11	0.11	0.00	0.07	0.14	0.12	0.19	0.11	0.19	0.15	0.13	0.26	0.27	0.18	0.16	0.15	0.34
85	TC	329	313	289	265	243	344	329	303	279	262	355	339	313	289	276	364	346	321	295	288
	SHC	134	151	182	211	237	141	164	201	236	262	149	175	218	262	276	156	186	234	279	288
	KW	21.1	20.8	20.4	20.1	19.8	21.5	21.2	20.7	20.4	20.1	21.7	21.4	20.9	20.5	20.3	21.9	21.5	21.1	20.6	20.5
	BF	0.00	0.09	0.13	0.11	0.11	0.00	0.21	0.14	0.12	0.20	0.09	0.18	0.14	0.14	0.28	0.24	0.17	0.15	0.16	0.36
95	TC	319	305	280	256	235	333	319	293	270	254	344	328	303	278	268	352	335	309	285	280
	SHC	130	148	178	207	230	137	160	196	234	254	145	172	214	254	268	153	182	230	273	280
	KW	23.5	23.3	23.0	22.7	22.4	23.8	23.6	23.3	23.0	22.6	24.1	23.8	23.4	23.1	22.9	24.3	24.0	23.6	23.1	23.1
	BF	0.00	0.08	0.13	0.10	0.13	0.13	0.19	0.13	0.12	0.22	0.08	0.17	0.14	0.13	0.30	0.23	0.17	0.15	0.16	0.37
105	TC	309	294	269	246	228	322	307	282	258	244	332	316	290	266	258	339	323	297	274	270
	SHC	125	144	173	202	226	133	156	192	226	244	142	168	209	248	258	149	178	225	264	270
	KW	26.3	26.1	25.9	25.7	25.4	26.6	26.4	26.2	25.9	25.7	26.9	26.7	26.3	26.0	25.8	27.0	26.8	26.4	26.0	26.0
	BF	0.00	0.07	0.12	0.10	0.16	0.10	0.17	0.13	0.12	0.24	0.25	0.16	0.14	0.14	0.33	0.20	0.16	0.15	0.18	0.40
115	TC	296	281	257	235	220	309	293	269	246	235	317	302	277	254	249	324	308	282	262	259
	SHC	120	139	168	196	218	129	151	186	221	235	137	162	203	242	249	144	172	219	254	259
	KW	29.3	29.3	29.4	29.5	29.3	29.7	29.6	29.5	29.5	29.4	30.0	29.8	29.6	29.5	29.4	30.2	29.9	29.7	29.4	29.4
	BF	0.00	0.20	0.12	0.10	0.19	0.08	0.15	0.12	0.12	0.27	0.21	0.15	0.13	0.14	0.35	0.19	0.16	0.15	0.20	0.42

48/50A027 (27 TONS) — STANDARD MODE (cont)

Temp (F) Air Entering Condenser (Edb)		Evaporator Air Quantity — Cfm														
		11,000					12,375					13,750				
		Evaporator Air — Ewb (F)														
		75	72	67	62	57	75	72	67	62	57	75	72	67	62	57
75	TC	384	365	337	311	307	389	371	342	319	316	394	375	346	324	324
	SHC	168	201	254	301	307	174	210	269	309	316	181	219	284	324	324
	KW	19.9	19.6	19.0	18.6	18.5	20.0	19.7	19.1	18.7	18.7	20.1	19.8	19.2	18.8	18.8
	BF	0.23	0.18	0.17	0.18	0.40	0.22	0.19	0.18	0.24	0.45	0.22	0.20	0.19	0.27	0.49
85	TC	370	353	326	302	299	375	358	331	309	307	380	362	334	315	315
	SHC	163	196	250	294	299	170	206	265	301	307	176	215	279	315	315
	KW	22.0	21.7	21.2	20.8	20.7	22.1	21.8	21.3	20.9	20.8	22.2	21.9	21.3	21.0	21.0
	BF	0.22	0.18	0.17	0.19	0.41	0.21	0.19	0.18	0.26	0.46	0.21	0.20	0.19	0.29	0.51
95	TC	358	342	315	292	290	363	346	319	299	298	368	350	322	306	305
	SHC	160	192	245	284	290	166	202	260	295	298	173	211	275	306	305
	KW	24.4	24.1	23.7	23.3	23.2	24.5	24.2	23.8	23.4	23.4	24.7	24.3	23.8	23.5	23.5
	BF	0.21	0.18	0.16	0.22	0.43	0.20	0.19	0.18	0.27	0.48	0.21	0.19	0.19	0.31	0.52
105	TC	345	328	301	281	280	350	332	305	288	288	353	336	308	295	295
	SHC	155	188	240	275	280	162	197	255	285	288	168	206	269	295	295
	KW	27.2	26.9	26.5	26.1	26.1	27.4	27.1	26.6	26.2	26.3	27.5	27.1	26.6	26.4	26.4
	BF	0.20	0.17	0.16	0.24	0.45	0.20	0.18	0.18	0.28	0.50	0.20	0.20	0.19	0.35	0.54
115	TC	329	312	287	268	268	333	316	290	276	276	336	320	293	283	282
	SHC	151	183	235	268	268	157	192	250	276	276	163	201	263	283	282
	KW	30.4	30.0	29.7	29.5	29.5	30.6	30.2	29.7	29.5	29.5	30.7	30.3	29.8	29.6	29.6
	BF	0.19	0.16	0.16	0.23	0.47	0.19	0.18	0.17	0.31	0.52	0.19	0.19	0.19	0.37	0.56

See legend on page 57.

Performance data (cont)



COOLING CAPACITIES (cont)

48/50A027 (27 TONS) — SUBCOOLING MODE

Temp (F) Air Entering Condenser (Edb)		Evaporator Air Quantity – SCFM																			
		5,400					6,750					8,100					9,450				
		Evaporator Air Ewb (F)																			
		75	72	67	62	57	75	72	67	62	57	75	72	67	62	57	75	72	67	62	57
75	TC	329	312	279	257	232	343	320	292	265	251	363	343	313	284	263	360	343	312	286	271
	SHC	117	135	159	190	215	121	138	172	206	245	137	159	198	236	263	131	159	204	251	271
	kW	17.7	17.5	16.8	16.6	16.3	17.8	17.5	17.0	16.6	16.7	18.4	18.0	17.4	16.9	16.6	18.2	17.8	17.5	17.0	16.7
	BF	0.00	0.03	0.08	0.09	0.09	0.01	0.08	0.10	0.11	0.15	0.06	0.11	0.12	0.13	0.22	0.10	0.13	0.14	0.15	0.30
85	TC	311	295	267	234	211	329	310	284	258	227	342	324	295	269	242	339	322	305	278	255
	SHC	103	122	150	169	196	112	132	168	202	222	120	144	184	225	242	114	143	200	246	255
	kW	19.6	19.4	18.9	18.2	17.8	20.0	19.6	19.3	18.8	18.0	20.2	19.9	19.3	18.9	18.3	20.0	19.7	19.5	19.1	18.5
	BF	0.00	0.04	0.08	0.09	0.10	0.02	0.08	0.10	0.11	0.17	0.06	0.11	0.12	0.13	0.23	0.10	0.13	0.14	0.15	0.31
95	TC	283	267	242	219	197	309	292	266	233	213	316	293	267	243	237	329	309	284	260	251
	SHC	78	97	127	156	184	96	117	153	180	208	98	117	160	201	237	109	134	184	230	251
	kW	21.4	21.1	20.6	20.2	19.8	22.1	21.7	21.2	20.5	20.1	22.1	21.6	21.1	20.7	20.8	22.5	22.0	21.5	21.1	21.1
	BF	0.00	0.05	0.08	0.08	0.09	0.02	0.08	0.10	0.11	0.18	0.07	0.11	0.12	0.13	0.25	0.11	0.14	0.14	0.16	0.33
105	TC	275	260	229	204	192	278	263	247	217	208	294	282	258	236	222	299	289	265	241	233
	SHC	74	93	116	144	179	69	92	137	166	204	81	110	154	197	222	84	118	168	215	233
	kW	24.2	23.8	23.0	22.5	22.5	24.0	23.7	23.5	22.8	22.8	24.4	24.2	23.8	23.3	23.1	24.5	24.3	23.9	23.4	23.3
	BF	0.00	0.05	0.08	0.08	0.12	0.03	0.09	0.10	0.11	0.19	0.08	0.11	0.12	0.13	0.26	0.11	0.14	0.14	0.16	0.34
115	TC	245	241	217	196	169	267	251	230	200	192	276	253	230	209	196	283	267	245	216	216
	SHC	48	78	108	139	157	63	84	124	152	189	67	85	130	172	196	72	101	152	189	216
	kW	26.4	26.4	25.9	25.5	24.7	27.0	26.6	26.1	25.4	25.4	27.2	26.5	26.0	25.6	25.3	27.3	27.0	26.4	25.7	25.9
	BF	0.00	0.05	0.08	0.08	0.13	0.03	0.09	0.10	0.11	0.20	0.08	0.11	0.12	0.14	0.28	0.11	0.14	0.14	0.19	0.36

48/50A027 (27 TONS) — SUBCOOLING MODE (cont)

Temp (F) Air Entering Condenser (Edb)		Evaporator Air Quantity – SCFM														
		10,800					12,150					13,500				
		Evaporator Air Ewb (F)														
		75	72	67	62	57	75	72	67	62	57	75	72	67	62	57
75	TC	368	351	332	302	284	375	359	338	311	302	393	374	343	315	303
	SHC	137	169	232	278	284	144	181	246	298	302	163	199	260	309	303
	kW	18.2	18.0	17.8	17.3	16.9	18.4	18.0	17.9	17.5	17.2	18.9	18.5	18.0	17.5	17.2
	BF	0.13	0.15	0.16	0.18	0.36	0.15	0.17	0.18	0.20	0.42	0.17	0.19	0.19	0.25	0.46
85	TC	346	329	302	284	276	351	340	317	288	288	356	340	312	288	286
	SHC	120	152	205	263	276	126	167	229	275	288	131	170	233	283	286
	kW	20.1	19.8	19.4	19.2	19.1	20.2	20.0	19.7	19.1	19.3	20.2	20.0	19.5	19.1	19.1
	BF	0.13	0.16	0.16	0.18	0.38	0.15	0.17	0.18	0.23	0.43	0.18	0.19	0.19	0.27	0.47
95	TC	328	317	290	267	250	342	324	295	264	269	345	329	300	270	278
	SHC	107	144	198	247	250	121	155	211	252	269	125	164	225	265	278
	kW	22.2	22.1	21.7	21.3	20.8	22.8	22.3	21.7	21.1	21.3	22.7	22.4	21.8	21.2	21.5
	BF	0.13	0.16	0.16	0.20	0.39	0.16	0.17	0.18	0.24	0.44	0.18	0.19	0.19	0.28	0.49
105	TC	310	295	262	240	244	306	301	274	255	242	310	295	271	257	250
	SHC	94	127	174	221	244	90	137	194	244	242	95	135	201	255	250
	kW	24.8	24.5	23.7	23.3	23.5	24.6	24.6	24.0	23.7	23.3	24.7	24.4	23.9	23.7	23.5
	BF	0.14	0.16	0.16	0.22	0.40	0.16	0.17	0.18	0.26	0.45	0.18	0.19	0.19	0.29	0.50
115	TC	288	273	242	222	226	295	277	253	237	234	296	281	257	241	241
	SHC	77	110	158	204	226	84	117	178	228	234	86	126	191	241	241
	kW	27.4	27.1	26.3	25.8	26.1	27.7	27.1	26.6	26.3	26.3	27.6	27.3	26.7	26.4	26.4
	BF	0.14	0.16	0.16	0.23	0.42	0.16	0.17	0.18	0.27	0.47	0.18	0.19	0.20	0.30	0.51

See legend on page 57.

COOLING CAPACITIES (cont)

50A027 (27 TONS) — HOT GAS REHEAT MODE

Temp (F) Air Entering Condenser (Edb)		Air Entering Evaporator — Ewb (F)													
		75 Dry Bulb							75 Dry Bulb						
		62.5 Wet Bulb (50% RH)							65.3 Wet Bulb (60% RH)						
		Air Entering Evaporator — SCFM													
		5,400	6,750	8,100	9,450	10,800	12,150	13,500	5,400	6,750	8,100	9,450	10,800	12,150	13,500
40	TC	73	84	91	97	101	104	106	77	89	97	103	107	110	113
	SHC	-18	-6	7	18	29	41	51	-42	-33	-25	-16	-9	-1	8
	KW	18.8	17.7	17.0	16.7	16.4	16.3	16.1	19.9	18.6	17.8	17.4	17.1	16.9	16.7
	BF	0.05	0.07	0.08	0.10	0.11	0.13	0.14	0.04	0.06	0.08	0.10	0.11	0.13	0.14
50	TC	67	77	84	89	92	95	97	71	82	89	94	98	101	104
	SHC	-22	-9	2	14	25	36	47	-46	-37	-29	-21	-13	-5	3
	KW	19.3	18.2	17.5	17.2	16.9	16.7	16.6	20.4	19.1	18.3	17.9	17.6	17.3	17.2
	BF	0.05	0.07	0.08	0.10	0.11	0.13	0.14	0.04	0.06	0.08	0.10	0.11	0.13	0.14
60	TC	62	72	78	82	85	87	89	66	76	82	87	90	93	95
	SHC	-25	-13	-1	10	21	32	43	-49	-41	-33	-25	-17	-9	-1
	KW	19.9	18.7	18.0	17.7	17.4	17.2	17.1	20.9	19.6	18.8	18.4	18.1	17.8	17.7
	BF	0.05	0.07	0.08	0.10	0.11	0.13	0.14	0.04	0.06	0.08	0.10	0.11	0.13	0.14
70	TC	57	66	71	75	78	80	81	60	69	75	79	82	85	87
	SHC	-28	-16	-5	6	17	28	39	-53	-44	-36	-28	-21	-13	-5
	KW	20.5	19.3	18.6	18.2	18.0	17.8	17.6	21.6	20.2	19.4	18.9	18.6	18.4	18.2
	BF	0.05	0.07	0.08	0.10	0.11	0.13	0.14	0.04	0.06	0.08	0.10	0.11	0.13	0.14
75	TC	54	63	69	72	75	77	79	57	67	73	77	79	82	83
	SHC	-30	-18	-6	5	16	27	37	-54	-46	-38	-30	-22	-15	-7
	KW	20.9	19.6	18.9	18.5	18.3	18.1	17.9	21.9	20.5	19.7	19.2	18.9	18.7	18.5
	BF	0.05	0.07	0.08	0.10	0.11	0.13	0.14	0.04	0.06	0.08	0.10	0.11	0.13	0.14
80	TC	52	61	66	70	72	74	76	55	64	70	74	77	79	80
	SHC	-31	-19	-8	3	14	25	36	-55	-47	-39	-31	-24	-16	-8
	KW	21.2	20.0	19.3	18.9	18.6	18.4	18.2	22.2	20.8	20.0	19.6	19.2	19.0	18.8
	BF	0.05	0.07	0.08	0.10	0.11	0.13	0.14	0.04	0.06	0.08	0.10	0.11	0.13	0.14

50A027 (27 TONS) — HOT GAS REHEAT MODE (cont)

Temp (F) Air Entering Condenser (Edb)		Air Entering Evaporator — Ewb (F)													
		75 Dry Bulb							75 Dry Bulb						
		68.0 Wet Bulb (70% RH)							70.5 Wet Bulb (80% RH)						
		Air Entering Evaporator — SCFM													
		5,400	6,750	8,100	9,450	10,800	12,150	13,500	5,400	6,750	8,100	9,450	10,800	12,150	13,500
40	TC	81	94	103	109	113	117	120	85	99	108	114	119	123	126
	SHC	-66	-61	-56	-51	-46	-41	-36	-89	-87	-85	-83	-81	-79	-77
	KW	21.0	19.5	18.7	18.1	17.8	17.5	17.3	22.2	20.5	19.5	18.9	18.5	18.2	17.9
	BF	0.02	0.04	0.07	0.09	0.11	0.12	0.14	0.00	0.01	0.03	0.06	0.08	0.11	0.13
50	TC	75	86	94	100	104	108	110	78	91	99	105	110	113	116
	SHC	-70	-65	-60	-55	-50	-45	-40	-93	-91	-89	-87	-86	-83	-81
	KW	21.6	20.0	19.1	18.6	18.2	18.0	17.8	22.7	21.0	20.0	19.4	18.9	18.6	18.4
	BF	0.02	0.05	0.07	0.09	0.11	0.12	0.14	0.00	0.01	0.03	0.06	0.09	0.11	0.13
60	TC	69	79	87	92	96	99	101	72	84	92	97	101	105	107
	SHC	-73	-69	-64	-59	-54	-49	-44	-97	-95	-93	-91	-89	-87	-85
	KW	22.1	20.6	19.7	19.1	18.7	18.5	18.3	23.3	21.5	20.5	19.9	19.4	19.1	18.9
	BF	0.02	0.05	0.07	0.09	0.11	0.13	0.14	0.00	0.01	0.03	0.07	0.09	0.11	0.13
70	TC	63	73	79	84	88	91	93	66	77	84	90	94	97	99
	SHC	-76	-72	-67	-63	-58	-53	-48	-99	-98	-97	-95	-93	-91	-89
	KW	22.7	21.1	20.2	19.7	19.3	19.0	18.8	23.9	22.1	21.1	20.4	20.0	19.7	19.4
	BF	0.02	0.05	0.07	0.09	0.11	0.13	0.14	0.00	0.01	0.04	0.07	0.09	0.11	0.13
75	TC	60	70	77	81	84	87	89	63	74	80	85	89	92	94
	SHC	-78	-73	-69	-64	-60	-55	-50	-101	-100	-98	-97	-95	-93	-91
	KW	23.0	21.4	20.5	20.0	19.6	19.3	19.1	24.2	22.4	21.4	20.7	20.3	20.0	19.7
	BF	0.02	0.05	0.07	0.09	0.11	0.13	0.14	0.00	0.01	0.04	0.07	0.09	0.11	0.13
80	TC	58	68	74	78	81	83	85	60	71	78	82	86	88	91
	SHC	-80	-75	-70	-66	-61	-56	-52	-103	-101	-100	-98	-97	-95	-93
	KW	23.4	21.8	20.9	20.3	19.9	19.6	19.4	24.6	22.8	21.7	21.0	20.6	20.3	20.0
	BF	0.02	0.05	0.07	0.09	0.11	0.13	0.14	0.00	0.01	0.04	0.07	0.09	0.12	0.13

See legend on page 57.

Performance data (cont)



COOLING CAPACITIES (cont)

48/50A030 (30 TONS) — STANDARD MODE

Temp (F) Air Entering Condenser (Edb)		Evaporator Air Quantity — Cfm																			
		6,000					7,500					9,000					10,500				
		Evaporator Air — Ewb (F)																			
		75	72	67	62	57	75	72	67	62	57	75	72	67	62	57	75	72	67	62	57
75	TC	370	354	325	298	272	389	371	342	314	293	401	384	354	325	309	411	392	362	334	323
	SHC	151	169	203	234	263	157	184	224	262	287	167	196	243	288	309	176	208	261	311	323
	KW	20.2	19.9	19.5	19.2	18.8	20.6	20.3	19.8	19.4	18.9	20.9	20.6	20.1	19.6	19.3	21.1	20.7	20.2	19.8	19.5
	BF	0.00	0.00	0.12	0.10	0.10	0.00	0.19	0.12	0.11	0.20	0.13	0.16	0.13	0.12	0.26	0.22	0.16	0.14	0.14	0.34
85	TC	362	345	316	288	263	379	361	332	303	276	391	373	343	314	300	400	381	351	322	315
	SHC	147	166	199	230	257	154	180	219	257	276	164	193	238	282	300	172	204	256	305	315
	KW	22.8	22.5	22.1	21.8	21.4	23.2	22.9	22.5	22.1	21.6	23.5	23.2	22.7	22.3	22.0	23.7	23.4	22.9	22.4	22.2
	BF	0.00	0.00	0.12	0.09	0.10	0.00	0.17	0.12	0.11	0.13	0.26	0.16	0.13	0.12	0.28	0.21	0.16	0.14	0.14	0.35
95	TC	351	334	305	278	255	367	349	320	292	274	379	360	330	302	291	387	368	338	310	305
	SHC	143	162	194	225	250	151	176	214	252	274	160	188	233	277	291	168	200	251	298	305
	KW	25.7	25.5	25.1	25.1	24.7	26.1	25.9	25.5	25.3	25.0	26.4	26.2	25.8	25.4	25.1	26.7	26.3	25.9	25.4	25.3
	BF	0.00	0.10	0.11	0.09	0.12	0.00	0.16	0.12	0.10	0.21	0.23	0.15	0.13	0.12	0.30	0.19	0.15	0.14	0.15	0.37
105	TC	339	322	293	267	247	353	336	307	280	265	364	346	317	290	281	372	353	324	297	294
	SHC	138	157	189	219	242	147	171	209	246	265	155	183	228	271	281	163	195	246	291	294
	KW	29.0	28.9	29.0	29.3	28.7	29.3	29.3	29.3	29.4	29.1	29.8	29.5	29.4	29.3	29.0	30.1	29.6	29.5	29.2	29.1
	BF	0.00	0.20	0.11	0.09	0.15	0.13	0.15	0.11	0.10	0.24	0.20	0.14	0.12	0.12	0.33	0.18	0.14	0.14	0.16	0.40
115	TC	326	309	281	256	237	339	322	294	268	256	349	331	303	277	271	356	338	309	286	283
	SHC	132	153	184	214	235	142	166	204	241	256	150	178	222	264	271	158	190	240	280	283
	KW	32.8	33.1	33.8	34.3	34.3	33.3	33.4	33.8	34.2	34.0	33.8	33.5	33.8	34.0	33.8	34.1	34.0	33.8	33.5	33.7
	BF	0.00	0.16	0.10	0.08	0.16	0.24	0.13	0.11	0.10	0.26	0.18	0.13	0.12	0.13	0.35	0.17	0.14	0.13	0.19	0.42

48/50A030 (30 TONS) — STANDARD MODE (cont)

Temp (F) Air Entering Condenser (Edb)		Evaporator Air Quantity — Cfm														
		12,000					13,500					15,000				
		Evaporator Air — Ewb (F)														
		75	72	67	62	57	75	72	67	62	57	75	72	67	62	57
75	TC	419	399	369	340	336	426	406	374	347	346	430	411	379	356	354
	SHC	183	219	278	330	336	191	229	294	343	346	198	240	310	351	354
	KW	21.3	20.9	20.4	19.9	19.7	21.4	21.0	20.5	19.9	19.9	21.5	21.1	20.6	20.1	20.1
	BF	0.20	0.16	0.15	0.17	0.40	0.20	0.18	0.16	0.22	0.45	0.20	0.18	0.17	0.28	0.49
85	TC	408	388	357	329	326	414	394	362	338	336	418	398	366	344	345
	SHC	180	215	273	322	326	187	226	290	331	336	194	236	305	337	345
	KW	23.9	23.5	23.0	22.5	22.4	24.0	23.7	23.1	22.6	22.6	24.1	23.8	23.2	22.7	22.8
	BF	0.19	0.16	0.15	0.19	0.41	0.19	0.17	0.16	0.26	0.46	0.19	0.18	0.17	0.28	0.50
95	TC	394	375	344	318	316	399	380	348	328	326	403	384	352	334	334
	SHC	175	211	268	312	316	182	221	284	320	326	189	231	300	334	334
	KW	26.9	26.6	26.0	25.4	25.5	27.0	26.7	26.1	25.6	25.6	27.2	26.8	26.2	25.8	25.8
	BF	0.18	0.16	0.15	0.21	0.43	0.18	0.17	0.16	0.28	0.48	0.19	0.18	0.17	0.31	0.52
105	TC	378	359	329	307	305	383	364	334	314	314	387	367	337	322	322
	SHC	170	205	262	301	305	177	215	278	314	314	184	225	294	322	322
	KW	30.3	30.0	29.6	29.0	29.2	30.5	30.1	29.6	29.3	29.3	30.7	30.2	29.7	29.4	29.3
	BF	0.17	0.16	0.15	0.24	0.45	0.18	0.17	0.16	0.28	0.50	0.18	0.18	0.17	0.34	0.54
115	TC	361	343	314	295	293	366	347	318	302	302	369	351	321	310	309
	SHC	165	200	257	290	293	172	210	272	302	302	179	220	288	310	309
	KW	34.4	34.2	33.9	33.4	33.6	34.7	34.3	33.9	33.6	33.6	34.9	34.4	33.9	33.7	33.7
	BF	0.17	0.16	0.15	0.26	0.47	0.17	0.17	0.16	0.31	0.52	0.18	0.18	0.18	0.36	0.56

See legend on page 57.

COOLING CAPACITIES (cont)

48/50A030 (30 TONS) — SUBCOOLING MODE

Temp (F) Air Entering Condenser (Edb)		Evaporator Air Quantity – SCFM																			
		6,000					7,500					9,000					10,500				
		Evaporator Air Ewb (F)																			
		75	72	67	62	57	75	72	67	62	57	75	72	67	62	57	75	72	67	62	57
75	TC	347	329	302	276	248	360	342	314	292	265	373	355	329	304	285	387	367	337	313	298
	SHC	126	146	178	208	234	132	155	193	235	260	140	167	215	260	285	152	181	231	282	298
	kW	19.8	19.4	18.9	18.5	18.1	20.1	19.7	19.2	18.8	18.3	20.3	20.0	19.4	19.0	18.7	20.6	20.2	19.6	19.1	18.9
	BF	0.00	0.05	0.09	0.10	0.11	0.02	0.09	0.11	0.12	0.17	0.08	0.12	0.14	0.14	0.25	0.12	0.15	0.16	0.17	0.33
85	TC	326	309	285	262	239	345	322	301	277	251	354	337	311	287	271	365	347	318	295	285
	SHC	109	130	164	197	226	121	139	183	223	247	126	153	200	246	271	135	165	215	267	285
	kW	22.0	21.6	21.2	20.8	20.5	22.3	21.9	21.4	21.0	20.6	22.5	22.2	21.6	21.2	21.0	22.7	22.4	21.8	21.3	21.2
	BF	0.00	0.05	0.09	0.09	0.11	0.03	0.10	0.11	0.12	0.18	0.08	0.12	0.14	0.14	0.27	0.12	0.15	0.16	0.17	0.34
95	TC	309	294	267	243	224	325	308	282	259	242	335	319	293	270	252	343	327	300	276	269
	SHC	97	118	149	182	214	105	129	168	209	239	112	140	186	232	252	119	150	202	251	269
	kW	24.6	24.2	23.8	23.4	23.1	24.9	24.5	24.0	23.6	23.4	25.1	24.7	24.2	23.8	23.5	25.3	24.9	24.3	23.9	23.8
	BF	0.00	0.06	0.09	0.09	0.11	0.04	0.10	0.11	0.12	0.19	0.09	0.13	0.14	0.14	0.28	0.12	0.15	0.16	0.17	0.35
105	TC	295	257	236	228	210	305	278	264	242	227	315	295	274	252	241	323	307	284	259	253
	SHC	87	86	122	170	201	90	103	155	195	225	97	121	172	219	241	104	135	191	239	253
	kW	27.6	26.9	26.5	26.4	26.3	27.8	27.3	27.0	26.6	26.4	28.0	27.6	27.2	26.8	26.6	28.2	27.8	27.3	26.9	26.8
	BF	0.00	0.06	0.09	0.09	0.13	0.04	0.10	0.11	0.12	0.21	0.09	0.13	0.14	0.15	0.29	0.13	0.15	0.16	0.17	0.37
115	TC	271	254	233	212	196	274	268	246	223	207	293	279	256	233	224	287	286	262	241	235
	SHC	69	88	124	157	187	66	99	141	180	207	81	111	159	203	224	73	120	174	220	235
	kW	30.9	30.6	30.3	30.0	29.9	31.0	30.8	30.4	30.1	29.9	31.4	31.0	30.5	30.2	30.1	31.2	31.1	30.6	30.2	30.2
	BF	0.01	0.07	0.09	0.09	0.15	0.05	0.10	0.11	0.12	0.21	0.10	0.13	0.14	0.15	0.31	0.13	0.15	0.16	0.20	0.38

48/50A030 (30 TONS) — SUBCOOLING MODE (cont)

Temp (F) Air Entering Condenser (Edb)		Evaporator Air Quantity – SCFM														
		12,000					13,500					15,000				
		Evaporator Air Ewb (F)														
		75	72	67	62	57	75	72	67	62	57	75	72	67	62	57
75	TC	395	375	346	320	313	396	381	348	321	322	401	387	355	328	326
	SHC	159	192	248	301	313	160	202	260	311	322	166	211	277	324	326
	kW	20.8	20.4	19.8	19.3	19.1	20.8	20.5	19.8	19.3	19.3	20.9	20.6	19.9	19.4	19.4
	BF	0.14	0.17	0.18	0.20	0.39	0.17	0.19	0.19	0.24	0.45	0.19	0.21	0.21	0.28	0.49
85	TC	369	352	324	298	296	378	357	330	309	306	379	362	334	315	312
	SHC	139	174	231	284	296	149	183	246	300	306	151	192	261	314	312
	kW	22.9	22.5	21.9	21.4	21.4	23.0	22.6	22.0	21.6	21.5	23.1	22.7	22.1	21.7	21.6
	BF	0.15	0.17	0.18	0.19	0.40	0.17	0.19	0.19	0.25	0.45	0.19	0.21	0.21	0.28	0.50
95	TC	350	333	307	285	280	354	338	311	289	286	359	342	315	294	296
	SHC	125	159	218	270	280	130	169	233	280	286	137	178	247	294	296
	kW	25.4	25.0	24.5	24.0	24.0	25.5	25.1	24.6	24.1	24.1	25.6	25.2	24.6	24.2	24.2
	BF	0.15	0.17	0.18	0.21	0.41	0.17	0.19	0.19	0.26	0.46	0.19	0.21	0.21	0.29	0.51
105	TC	331	315	273	266	260	337	301	294	274	271	341	321	296	278	277
	SHC	112	147	189	252	260	119	137	221	267	271	124	162	233	278	277
	kW	28.4	28.0	27.2	27.0	26.9	28.5	27.8	27.5	27.1	27.1	28.6	28.1	27.5	27.2	27.2
	BF	0.15	0.17	0.18	0.23	0.43	0.17	0.19	0.19	0.27	0.48	0.19	0.21	0.21	0.31	0.52
115	TC	307	291	268	248	243	311	295	271	254	251	313	299	274	258	258
	SHC	94	129	190	235	243	99	138	203	248	251	104	147	217	258	258
	kW	31.7	31.3	30.7	30.3	30.3	31.8	31.4	30.8	30.4	30.4	31.9	31.4	30.8	30.5	30.5
	BF	0.15	0.17	0.17	0.24	0.44	0.18	0.19	0.19	0.28	0.49	0.20	0.21	0.21	0.32	0.53

See legend on page 57.

Performance data (cont)



COOLING CAPACITIES (cont)

50A030 (30 TONS) — HOT GAS REHEAT MODE

Temp (F) Air Entering Condenser (Edb)		Air Entering Evaporator — Ewb (F)													
		75 Dry Bulb							75 Dry Bulb						
		62.5 Wet Bulb (50% RH)							65.3 Wet Bulb (60% RH)						
		Air Entering Evaporator — SCFM													
		6,000	7,500	9,000	10,500	12,000	13,500	15,000	6,000	7,500	9,000	10,500	12,000	13,500	15,000
40	TC	138	148	154	159	164	167	169	145	155	162	168	172	176	179
	SHC	35	48	61	73	86	99	111	10	19	28	38	47	56	66
	KW	17.0	16.7	16.6	16.5	16.5	16.5	16.5	17.8	17.4	17.3	17.2	17.1	17.1	17.1
	BF	0.07	0.09	0.11	0.12	0.14	0.16	0.17	0.06	0.08	0.10	0.12	0.14	0.16	0.17
50	TC	133	142	149	153	157	159	161	139	149	156	161	165	168	170
	SHC	31	44	57	70	83	95	107	7	16	25	34	43	52	62
	KW	17.9	17.5	17.4	17.3	17.3	17.3	17.3	18.7	18.2	18.1	18.0	17.9	17.9	17.9
	BF	0.07	0.09	0.11	0.12	0.14	0.16	0.17	0.06	0.08	0.10	0.12	0.14	0.16	0.17
60	TC	127	136	142	147	150	153	155	133	143	150	154	158	161	163
	SHC	28	41	54	67	79	92	104	3	12	21	30	40	49	58
	KW	18.8	18.5	18.3	18.2	18.2	18.2	18.1	19.6	19.2	19.0	18.8	18.8	18.7	18.7
	BF	0.07	0.09	0.11	0.12	0.14	0.16	0.17	0.06	0.08	0.10	0.12	0.14	0.16	0.17
70	TC	120	129	135	140	143	145	147	127	136	143	147	151	153	155
	SHC	24	37	50	63	75	88	100	0	9	18	27	36	45	54
	KW	19.9	19.5	19.3	19.2	19.2	19.1	19.1	20.7	20.2	20.0	19.8	19.8	19.7	19.7
	BF	0.07	0.09	0.11	0.12	0.14	0.16	0.17	0.06	0.08	0.10	0.12	0.14	0.16	0.17
75	TC	117	126	132	136	139	142	143	124	133	139	143	147	149	151
	SHC	22	35	48	61	74	86	98	-2	7	16	25	34	43	52
	KW	20.5	20.1	19.9	19.8	19.7	19.7	19.7	21.3	20.8	20.5	20.4	20.3	20.2	20.2
	BF	0.07	0.09	0.11	0.12	0.14	0.16	0.17	0.06	0.08	0.10	0.12	0.14	0.16	0.17
80	TC	114	123	128	133	136	138	139	120	129	135	140	143	145	147
	SHC	20	33	46	59	72	84	96	-4	5	14	23	32	41	51
	KW	21.1	20.7	20.5	20.4	20.3	20.3	20.2	21.9	21.4	21.1	21.0	20.9	20.8	20.8
	BF	0.07	0.09	0.11	0.12	0.14	0.16	0.17	0.06	0.08	0.10	0.12	0.14	0.16	0.17

50A030 (30 TONS) — HOT GAS REHEAT MODE (cont)

Temp (F) Air Entering Condenser (Edb)		Air Entering Evaporator — Ewb (F)													
		75 Dry Bulb							75 Dry Bulb						
		68.0 Wet Bulb (70% RH)							70.5 Wet Bulb (80% RH)						
		Air Entering Evaporator — SCFM													
		6,000	7,500	9,000	10,500	12,000	13,500	15,000	6,000	7,500	9,000	10,500	12,000	13,500	15,000
40	TC	151	162	170	176	181	185	188	158	170	178	184	189	193	196
	SHC	-14	-9	-3	2	8	14	20	-38	-35	-33	-31	-28	-25	-22
	KW	18.6	18.2	18.0	17.8	17.8	17.7	17.7	19.5	19.0	18.7	18.5	18.4	18.3	18.3
	BF	0.02	0.06	0.09	0.12	0.14	0.16	0.17	0.00	0.00	0.04	0.08	0.11	0.14	0.16
50	TC	146	156	163	169	173	176	179	152	163	171	176	181	184	187
	SHC	-17	-12	-7	-1	4	10	16	-41	-39	-37	-34	-32	-29	-26
	KW	19.5	19.0	18.7	18.6	18.5	18.5	18.4	20.4	19.8	19.4	19.3	19.2	19.1	19.0
	BF	0.02	0.06	0.09	0.12	0.14	0.16	0.17	0.00	0.00	0.05	0.09	0.11	0.14	0.16
60	TC	140	150	157	162	166	169	171	146	156	164	169	173	176	179
	SHC	-21	-16	-10	-5	1	7	13	-44	-42	-40	-38	-35	-33	-30
	KW	20.4	19.9	19.6	19.5	19.4	19.3	19.3	21.3	20.7	20.3	20.1	20.0	19.9	19.9
	BF	0.03	0.07	0.09	0.12	0.14	0.16	0.17	0.00	0.00	0.05	0.09	0.12	0.14	0.16
70	TC	133	143	150	155	158	161	163	139	150	157	162	166	169	171
	SHC	-24	-19	-14	-8	-3	3	9	-48	-45	-44	-41	-39	-36	-33
	KW	21.5	20.9	20.6	20.5	20.4	20.3	20.2	22.3	21.7	21.3	21.1	21.0	20.9	20.8
	BF	0.03	0.07	0.09	0.12	0.14	0.16	0.17	0.00	0.01	0.06	0.09	0.12	0.14	0.16
75	TC	130	140	146	151	154	157	159	136	146	153	158	162	165	167
	SHC	-26	-21	-16	-10	-5	1	7	-49	-47	-45	-43	-41	-38	-35
	KW	22.1	21.5	21.2	21.0	20.9	20.8	20.8	22.9	22.2	21.9	21.6	21.5	21.4	21.4
	BF	0.04	0.07	0.09	0.12	0.14	0.16	0.17	0.00	0.01	0.06	0.09	0.12	0.14	0.16
80	TC	127	136	142	147	150	153	155	132	142	149	154	158	161	163
	SHC	-28	-23	-18	-12	-6	-1	5	-51	-49	-47	-45	-43	-40	-37
	KW	22.7	22.1	21.8	21.6	21.5	21.4	21.4	23.5	22.8	22.4	22.2	22.1	22.0	21.9
	BF	0.04	0.07	0.10	0.12	0.14	0.16	0.17	0.00	0.02	0.06	0.09	0.12	0.14	0.16

See legend on page 57.

COOLING CAPACITIES (cont)

48/50A035 (35 TONS) — STANDARD MODE

Temp (F) Air Entering Condenser (Edb)		Evaporator Air Quantity — Cfm																			
		7,000					8,750					10,500					12,250				
		Evaporator Air — Ewb (F)																			
		75	72	67	62	57	75	72	67	62	57	75	72	67	62	57	75	72	67	62	57
75	TC	442	423	394	366	338	459	440	410	383	363	471	452	421	395	383	479	460	430	403	399
	SHC	179	206	250	291	329	189	222	275	327	363	199	237	299	359	383	208	252	323	389	399
	kW	24.8	24.3	23.6	23.2	23.1	25.3	24.7	24.0	23.4	23.2	25.6	25.1	24.3	23.6	23.4	25.8	25.3	24.5	23.8	23.7
	BF	0.00	0.00	0.00	0.01	0.02	0.00	0.00	0.01	0.01	0.10	0.01	0.01	0.01	0.02	0.21	0.01	0.02	0.02	0.04	0.29
85	TC	428	412	384	354	326	444	426	399	372	352	455	437	410	384	374	463	444	417	393	389
	SHC	174	201	245	285	322	184	217	270	321	352	193	231	294	354	374	203	246	318	384	389
	kW	27.8	27.3	26.9	26.7	27.0	28.2	27.7	27.1	26.8	26.7	28.5	28.0	27.3	26.9	26.8	28.8	28.2	27.5	27.0	26.9
	BF	0.00	0.00	0.01	0.01	0.02	0.00	0.00	0.01	0.01	0.13	0.01	0.01	0.01	0.03	0.23	0.02	0.02	0.02	0.05	0.31
95	TC	417	400	371	341	312	432	415	387	358	341	441	424	397	370	362	447	431	405	380	378
	SHC	170	197	239	279	312	179	212	265	314	341	188	227	289	348	362	197	241	313	376	378
	kW	31.3	31.1	30.8	31.3	32.9	31.6	31.2	30.9	30.8	31.2	31.9	31.4	31.0	30.8	30.7	32.1	31.6	31.0	30.8	30.8
	BF	0.00	0.00	0.01	0.01	0.03	0.00	0.00	0.01	0.01	0.16	0.01	0.01	0.02	0.03	0.25	0.02	0.02	0.02	0.05	0.33
105	TC	403	385	356	325	308	417	400	372	343	328	427	410	381	355	349	433	417	389	365	365
	SHC	165	191	232	271	308	174	207	258	307	328	184	222	283	340	349	193	236	307	365	365
	kW	35.5	35.4	36.0	37.7	39.3	35.7	35.5	35.5	36.5	37.4	35.9	35.5	35.3	35.8	36.1	36.0	35.6	35.3	35.5	35.5
	BF	0.00	0.00	0.01	0.01	0.12	0.00	0.01	0.01	0.02	0.19	0.01	0.01	0.02	0.03	0.28	0.02	0.02	0.02	0.07	0.35
115	TC	380	364	337	—	—	391	376	351	—	—	398	384	360	335	332	403	389	366	347	347
	SHC	156	182	224	—	—	165	198	250	—	—	174	213	274	330	332	183	227	298	347	347
	kW	39.4	39.7	40.9	—	—	39.5	39.5	40.1	—	—	39.5	39.4	39.8	40.9	41.1	39.6	39.4	39.6	40.2	40.2
	BF	0.00	0.00	0.01	—	—	0.00	0.01	0.01	—	—	0.01	0.01	0.02	0.04	0.31	0.01	0.02	0.02	0.12	0.39

48/50A035 (35 TONS) — STANDARD MODE (cont)

Temp (F) Air Entering Condenser (Edb)		Evaporator Air Quantity — Cfm														
		14,000					15,750					17,500				
		Evaporator Air — Ewb (F)														
		75	72	67	62	57	75	72	67	62	57	75	72	67	62	57
75	TC	485	466	436	412	411	490	471	442	422	422	—	475	446	432	432
	SHC	217	266	347	411	411	226	281	369	422	422	—	295	391	432	432
	kW	26.0	25.5	24.7	24.0	24.0	26.1	25.6	24.8	24.3	24.3	—	25.7	24.9	24.5	24.5
	BF	0.02	0.02	0.03	0.09	0.36	0.03	0.03	0.04	0.17	0.42	—	0.04	0.05	0.23	0.46
85	TC	469	451	422	402	401	—	455	426	411	411	—	459	431	419	419
	SHC	212	261	341	402	401	—	275	363	411	411	—	290	384	419	419
	kW	29.0	28.4	27.6	27.1	27.1	—	28.6	27.7	27.3	27.3	—	28.7	27.8	27.5	27.5
	BF	0.02	0.02	0.03	0.11	0.38	—	0.03	0.04	0.19	0.43	—	0.04	0.05	0.26	0.48
95	TC	—	436	410	391	390	—	439	414	401	400	—	443	418	409	408
	SHC	—	256	336	391	390	—	270	358	401	400	—	284	379	409	408
	kW	—	31.7	31.1	30.9	30.9	—	31.8	31.2	31.0	31.0	—	31.9	31.3	31.1	31.1
	BF	—	0.02	0.03	0.13	0.39	—	0.03	0.04	0.21	0.45	—	0.04	0.06	0.27	0.49
105	TC	—	421	394	377	377	—	425	399	387	386	—	428	403	395	395
	SHC	—	251	330	377	377	—	265	352	387	386	—	279	373	395	395
	kW	—	35.7	35.3	35.3	35.3	—	35.7	35.3	35.2	35.2	—	35.8	35.3	35.3	35.3
	BF	—	0.03	0.03	0.16	0.42	—	0.03	0.04	0.24	0.47	—	0.04	0.06	0.30	0.51
115	TC	—	393	371	358	358	—	396	375	367	367	—	399	378	374	374
	SHC	—	242	321	358	358	—	256	342	367	367	—	270	362	374	374
	kW	—	39.4	39.4	39.7	39.7	—	39.5	39.4	39.5	39.5	—	39.5	39.3	39.4	39.4
	BF	—	0.02	0.03	0.21	0.45	—	0.03	0.05	0.28	0.49	—	0.04	0.07	0.34	0.54

LEGEND

- BF** — Bypass Factor
 - Edb** — Entering Dry Bulb
 - Ewb** — Entering Wet Bulb
 - kW** — Compressor Motor Power Input
 - RH** — Relative Humidity
 - SCFM** — Standard Cubic Feet per Minute
 - SHC** — Sensible Heat Capacity (1000 Btuh)
 - TC** — Total Capacity (1000 Btuh) Gross
 - VAV** — Variable Air Volume
- Boldface** — VAV Units Only

NOTES:

1. Direct interpolation is permissible. Do not extrapolate.
2. The following formulas may be used:

$$t_{ldb} = t_{edb} - \frac{\text{sensible capacity (Btuh)}}{1.10 \times \text{cfm}}$$

$$t_{lwb} = \text{Wet-bulb temperature corresponding to enthalpy of air leaving evaporator coil (} h_{lwb} \text{)}$$

$$h_{lwb} = h_{ewb} - \frac{\text{total capacity (Btuh)}}{4.5 \times \text{cfm}}$$

Where: h_{ewb} = Enthalpy of air entering evaporator coil.

3. The SHC is based on 80 F edb temperature of air entering evaporator coil.
Below 80 F edb, subtract (corr factor x cfm) from SHC.
Above 80 F edb, add (corr factor x cfm) to SHC.

		ENTERING AIR DRY-BULB TEMP (F)					
		79	78	77	76	75	under 75
BF	81	82	83	84	85	over 85	
	Correction Factor						
.05	1.04	2.07	3.11	4.14	4.18	Use formula shown below.	
.10	.98	1.96	2.94	3.92	4.91		
.20	.87	1.74	2.62	3.49	4.36		

Interpolation is permissible.
Correction Factor = $1.10 \times (1 - \text{BF}) \times (\text{edb} - 80)$.

4. Cooling capacities are gross and do not include deduction for indoor fan motor heat.
5. Variable air volume units will operate down to 70 cfm/ton. Performance at 70 cfm/ton is limited to unloaded operation and may be additionally limited by edb and ewb conditions or Humidi-MiZer® operation.

Performance data (cont)



COOLING CAPACITIES (cont)

48/50A035 (35 TONS) — SUBCOOLING MODE

Temp (F) Air Entering Condenser (Edb)		Evaporator Air Quantity – SCFM																			
		7,000					8,750					10,500					12,250				
		Evaporator Air Ewb (F)																			
		75	72	67	62	57	75	72	67	62	57	75	72	67	62	57	75	72	67	62	57
75	TC	413	378	346	305	268	417	409	369	329	286	450	404	385	346	318	460	433	389	360	345
	SHC	132	145	188	220	249	125	171	216	259	282	153	166	242	294	318	161	199	260	327	345
	kW	23.6	23.0	22.8	22.3	22.0	23.7	23.5	23.0	22.6	21.7	24.1	23.4	23.2	22.7	22.2	24.3	23.9	23.2	22.9	22.8
	BF	0.00	0.00	0.02	0.02	0.03	0.00	0.02	0.02	0.03	0.09	0.02	0.03	0.03	0.04	0.18	0.04	0.04	0.04	0.06	0.27
85	TC	373	356	316	277	240	397	353	337	288	257	393	386	351	314	291	402	377	343	327	304
	SHC	96	126	161	194	224	109	119	187	221	254	101	152	212	265	291	107	146	217	297	304
	kW	25.9	25.8	25.3	25.0	24.7	26.3	25.6	25.5	24.7	24.2	26.3	26.1	25.7	25.2	24.9	26.5	26.0	25.5	25.4	24.9
	BF	0.00	0.01	0.02	0.02	0.03	0.00	0.02	0.02	0.03	0.10	0.02	0.03	0.03	0.04	0.19	0.04	0.04	0.04	0.07	0.28
95	TC	347	324	285	246	200	344	320	303	267	222	355	329	297	280	263	361	337	303	292	272
	SHC	75	98	134	167	184	61	90	158	203	220	67	100	162	235	263	72	112	181	265	272
	kW	29.0	28.7	28.2	27.9	26.8	28.9	28.5	28.4	28.0	27.2	29.1	28.6	28.2	28.1	28.0	29.3	28.8	28.2	28.2	27.8
	BF	0.00	0.01	0.02	0.02	0.05	0.01	0.02	0.02	0.03	0.11	0.02	0.03	0.03	0.05	0.21	0.04	0.04	0.04	0.07	0.29
105	TC	306	281	253	214	182	307	278	269	234	206	314	313	249	247	231	319	296	284	259	250
	SHC	38	60	106	139	168	30	53	129	174	206	31	89	119	206	231	35	75	167	233	250
	kW	32.1	31.7	31.6	31.3	31.2	32.1	31.5	31.7	31.4	31.2	32.3	32.3	31.1	31.5	31.4	32.4	31.9	31.8	31.6	31.5
	BF	0.00	0.01	0.02	0.02	0.07	0.01	0.02	0.02	0.03	0.13	0.02	0.03	0.03	0.05	0.23	0.04	0.04	0.04	0.09	0.31
115	TC	281	249	221	173	143	291	242	226	201	165	272	251	219	213	172	275	253	247	223	204
	SHC	20	34	79	102	130	19	23	91	146	165	-4	33	95	175	172	-3	39	136	199	204
	kW	36.5	35.7	35.7	34.8	34.6	36.5	35.3	35.2	35.5	34.6	36.0	35.4	34.9	35.5	34.4	36.1	35.5	35.5	35.4	34.9
	BF	0.00	0.01	0.02	0.02	0.09	0.01	0.02	0.02	0.03	0.15	0.02	0.03	0.03	0.06	0.24	0.04	0.04	0.04	0.11	0.32

48/50A035 (35 TONS) — SUBCOOLING MODE (cont)

Temp (F) Air Entering Condenser (Edb)		Evaporator Air Quantity – SCFM														
		14,000					15,750					17,500				
		Evaporator Air Ewb (F)														
		75	72	67	62	57	75	72	67	62	57	75	72	67	62	57
75	TC	452	443	399	372	365	460	434	410	383	381	465	438	414	384	394
	SHC	154	214	284	356	365	163	213	311	379	381	171	225	330	384	394
	kW	24.2	24.0	23.4	23.1	23.0	24.4	24.0	23.5	23.2	23.2	24.5	24.1	23.6	23.1	23.4
	BF	0.05	0.05	0.05	0.10	0.34	0.06	0.06	0.07	0.14	0.39	0.08	0.07	0.08	0.20	0.44
85	TC	409	384	351	338	333	415	391	371	349	337	420	394	378	350	358
	SHC	115	159	240	323	333	123	175	276	345	337	131	185	299	350	358
	kW	26.6	26.2	25.7	25.5	25.5	26.8	26.3	25.9	25.7	25.4	26.9	26.4	26.1	25.6	25.9
	BF	0.05	0.05	0.05	0.11	0.35	0.06	0.06	0.07	0.15	0.40	0.08	0.07	0.08	0.21	0.45
95	TC	367	342	299	304	299	371	347	313	304	303	374	351	318	316	323
	SHC	78	122	193	290	299	84	135	221	301	303	91	147	242	316	323
	kW	29.4	28.9	28.1	28.4	28.3	29.5	29.0	28.4	28.3	28.2	29.6	29.1	28.5	28.4	28.6
	BF	0.05	0.05	0.05	0.12	0.36	0.06	0.06	0.07	0.17	0.41	0.08	0.07	0.08	0.22	0.46
105	TC	320	299	291	260	254	325	302	268	278	275	328	305	262	287	281
	SHC	37	85	189	247	254	44	95	182	276	275	50	107	191	287	281
	kW	32.5	32.0	31.9	31.4	31.3	32.7	32.0	31.4	31.8	31.7	32.8	32.1	31.3	31.9	31.7
	BF	0.05	0.05	0.06	0.13	0.37	0.07	0.06	0.07	0.18	0.42	0.08	0.07	0.08	0.24	0.47
115	TC	277	256	227	234	229	279	257	268	238	240	278	256	270	243	249
	SHC	0	48	130	222	229	4	57	188	238	240	7	64	205	243	249
	kW	36.2	35.5	34.9	35.5	35.5	36.4	35.6	36.1	35.5	35.5	36.5	35.6	36.0	35.4	35.6
	BF	0.05	0.05	0.06	0.15	0.38	0.07	0.06	0.07	0.19	0.44	0.08	0.07	0.09	0.26	0.48

See legend on page 57.

COOLING CAPACITIES (cont)

50A035 (35 TONS) — HOT GAS REHEAT MODE

Temp (F) Air Entering Condenser (Edb)		Air Entering Evaporator — Ewb (F)													
		75 Dry Bulb							75 Dry Bulb						
		62.5 Wet Bulb (50% RH)							65.3 Wet Bulb (60% RH)						
		Air Entering Evaporator — SCFM													
		7,000	8,750	10,500	12,250	14,000	15,750	17,500	7,000	8,750	10,500	12,250	14,000	15,750	17,500
40	TC	162	170	176	180	184	186	189	173	182	188	193	197	200	202
	SHC	46	61	77	94	111	128	144	18	27	37	48	60	71	83
	kW	23.4	23.0	22.8	22.7	22.6	22.5	22.4	24.6	24.2	23.9	23.7	23.6	23.5	23.4
	BF	0.00	0.01	0.01	0.02	0.03	0.04	0.05	0.00	0.01	0.01	0.02	0.03	0.04	0.05
50	TC	143	151	156	160	163	165	167	155	163	169	173	177	179	181
	SHC	31	45	61	78	95	111	128	3	12	22	32	44	55	67
	kW	24.1	23.8	23.6	23.4	23.3	23.2	23.2	25.4	24.9	24.7	24.5	24.3	24.3	24.2
	BF	0.00	0.01	0.01	0.02	0.03	0.04	0.05	0.00	0.01	0.01	0.02	0.03	0.04	0.05
60	TC	125	132	137	140	142	144	146	137	144	150	153	156	158	160
	SHC	15	29	45	62	78	95	111	-12	-4	6	16	28	39	51
	kW	24.9	24.6	24.4	24.2	24.1	24.1	24.0	26.2	25.8	25.5	25.3	25.2	25.1	25.0
	BF	0.00	0.01	0.01	0.02	0.03	0.04	0.05	0.00	0.01	0.01	0.02	0.03	0.04	0.05
70	TC	108	114	118	121	123	125	126	118	125	129	132	135	137	139
	SHC	-1	14	29	46	62	79	95	-27	-20	-10	0	11	23	35
	kW	24.8	25.5	25.3	25.1	25.0	25.0	24.9	27.2	26.7	26.4	26.2	26.1	26.0	25.9
	BF	0.01	0.01	0.01	0.02	0.03	0.04	0.05	0.00	0.01	0.01	0.02	0.03	0.04	0.05
75	TC	99	105	108	111	113	114	116	109	115	119	122	125	127	128
	SHC	-7	6	21	38	54	71	87	-35	-27	-18	-8	4	15	27
	kW	26.4	26.0	25.8	25.6	25.5	25.4	25.4	27.7	27.2	26.9	26.7	26.6	26.5	26.4
	BF	0.00	0.01	0.01	0.02	0.03	0.04	0.05	0.00	0.01	0.01	0.02	0.03	0.04	0.05
80	TC	90	96	99	101	103	104	106	100	106	110	112	115	117	118
	SHC	-15	-1	14	30	46	63	78	-43	-35	-26	-16	-4	7	19
	kW	26.9	26.5	26.3	26.2	26.0	26.0	25.9	28.2	27.7	27.4	27.2	27.1	27.0	26.9
	BF	0.00	0.01	0.01	0.02	0.03	0.04	0.05	0.00	0.01	0.01	0.02	0.03	0.04	0.05

50A035 (35 TONS) — HOT GAS REHEAT MODE (cont)

Temp (F) Air Entering Condenser (Edb)		Air Entering Evaporator — Ewb (F)													
		75 Dry Bulb							75 Dry Bulb						
		68.0 Wet Bulb (70% RH)							70.5 Wet Bulb (80% RH)						
		Air Entering Evaporator — SCFM													
		7,000	8,750	10,500	12,250	14,000	15,750	17,500	7,000	8,750	10,500	12,250	14,000	15,750	17,500
40	TC	184	193	200	205	209	212	215	193	204	211	215	220	222	223
	SHC	-10	-8	-4	1	7	13	19	-39	-42	-44	-44	-42	-40	-38
	kW	26.2	25.6	25.4	25.2	25.2	25.1	25.2	28.1	27.7	27.5	27.6	27.8	28.1	28.6
	BF	0.00	0.01	0.02	0.03	0.04	0.06	0.07	0.00	0.00	0.01	0.03	0.05	0.07	0.09
50	TC	165	175	181	185	189	192	195	175	184	191	196	201	203	204
	SHC	-25	-23	-20	-15	-9	-3	4	-54	-58	-60	-59	-58	-56	-54
	kW	26.9	26.4	26.1	26.0	25.9	25.9	25.9	28.8	28.4	28.2	28.3	28.5	28.8	29.2
	BF	0.00	0.01	0.02	0.03	0.04	0.05	0.07	0.00	0.00	0.01	0.03	0.05	0.07	0.09
60	TC	147	155	161	165	169	172	175	157	165	172	177	181	183	184
	SHC	-41	-39	-35	-31	-25	-19	-12	-69	-73	-75	-75	-73	-72	-70
	kW	27.8	27.2	26.9	26.8	26.7	26.7	26.7	29.7	29.2	29.0	29.1	29.3	29.6	30.0
	BF	0.00	0.01	0.02	0.03	0.04	0.05	0.07	0.00	0.00	0.01	0.03	0.05	0.07	0.09
70	TC	129	136	141	145	149	152	154	138	146	152	157	160	162	162
	SHC	-56	-55	-51	-46	-41	-35	-28	-84	-89	-90	-90	-89	-88	-86
	kW	28.7	28.2	27.8	27.7	27.6	27.6	27.7	30.6	30.1	29.9	30.0	30.2	30.5	30.9
	BF	0.00	0.01	0.02	0.03	0.04	0.05	0.07	0.00	0.00	0.01	0.03	0.05	0.07	0.09
75	TC	119	126	131	135	139	141	143	129	137	142	147	150	151	152
	SHC	-64	-62	-59	-54	-49	-43	-36	-92	-96	-98	-98	-97	-96	-94
	kW	29.2	28.7	28.3	28.2	28.1	28.1	28.1	31.1	30.6	30.4	30.5	30.7	31.0	31.3
	BF	0.00	0.01	0.02	0.03	0.04	0.05	0.07	0.00	0.00	0.01	0.03	0.05	0.07	0.09
80	TC	110	117	122	125	128	131	133	119	127	133	137	139	141	141
	SHC	-71	-70	-67	-62	-57	-51	-44	-99	-104	-106	-106	-105	-104	-102
	kW	29.7	29.2	28.9	28.7	28.6	28.6	28.7	31.6	31.1	30.9	31.0	31.2	31.5	31.8
	BF	0.00	0.01	0.02	0.03	0.04	0.05	0.07	0.00	0.00	0.01	0.03	0.05	0.07	0.09

See legend on page 57.

Performance data (cont)



COOLING CAPACITIES (cont)

48/50A040 (40 TONS) — STANDARD MODE

Temp (F) Air Entering Condenser (Edb)		Evaporator Air Quantity — Cfm																			
		8,000					10,000					12,000					14,000				
		Evaporator Air — Ewb (F)																			
		75	72	67	62	57	75	72	67	62	57	75	72	67	62	57	75	72	67	62	57
75	TC	517	495	459	423	388	542	518	482	445	415	558	533	498	461	439	570	546	509	473	460
	SHC	206	235	284	330	371	216	253	313	370	408	228	270	341	408	439	233	287	368	441	460
	KW	25.9	25.5	25.0	24.7	24.3	26.3	25.9	25.4	25.0	24.5	26.6	26.2	25.6	25.2	24.8	26.8	26.4	25.8	25.3	25.1
	BF	0.00	0.00	0.06	0.04	0.05	0.00	0.10	0.06	0.05	0.13	0.15	0.08	0.06	0.06	0.20	0.11	0.08	0.07	0.08	0.29
85	TC	503	481	446	410	376	525	504	467	431	405	541	519	483	447	427	552	531	494	458	448
	SHC	199	230	278	325	364	210	248	307	363	397	222	265	335	400	427	233	282	362	434	448
	KW	29.2	28.8	28.5	28.0	27.7	29.6	29.3	28.8	28.4	27.9	29.9	29.5	29.0	28.6	28.3	30.1	29.7	29.2	28.7	28.5
	BF	0.00	0.13	0.06	0.03	0.05	0.00	0.09	0.06	0.05	0.16	0.13	0.08	0.06	0.06	0.23	0.10	0.08	0.07	0.08	0.31
95	TC	489	467	431	395	363	510	488	452	416	390	525	503	466	429	414	536	514	477	442	434
	SHC	193	224	272	317	356	205	242	301	356	390	217	260	328	392	414	228	276	355	425	434
	KW	33.0	32.6	32.3	32.0	31.7	33.4	33.1	32.6	32.3	31.8	33.7	33.4	32.9	32.5	32.1	33.9	33.5	33.0	32.6	32.4
	BF	0.00	0.10	0.05	0.04	0.06	0.10	0.08	0.05	0.05	0.15	0.11	0.08	0.06	0.06	0.25	0.10	0.08	0.07	0.09	0.33
105	TC	473	451	414	381	350	492	470	434	399	378	506	484	447	412	401	516	493	457	423	419
	SHC	187	218	264	311	346	200	236	293	348	378	211	253	321	384	401	221	269	347	414	419
	KW	37.2	36.8	36.8	36.2	36.5	37.6	37.4	37.0	37.0	36.6	37.9	37.6	37.2	37.1	36.7	38.1	37.8	37.4	37.0	36.8
	BF	0.00	0.08	0.05	0.03	0.07	0.15	0.08	0.05	0.05	0.18	0.10	0.07	0.06	0.07	0.27	0.09	0.08	0.07	0.10	0.35
115	TC	453	432	397	364	337	471	450	415	381	364	483	462	427	394	386	492	472	436	405	403
	SHC	180	211	257	302	332	193	228	286	340	364	204	245	313	375	386	214	262	339	402	403
	KW	42.0	41.4	42.2	42.1	41.8	42.5	42.4	42.4	42.5	42.2	42.6	42.6	42.5	42.5	42.2	42.8	42.8	42.7	42.3	42.2
	BF	0.00	0.07	0.05	0.03	0.11	0.12	0.07	0.05	0.05	0.21	0.09	0.07	0.06	0.07	0.30	0.08	0.07	0.06	0.11	0.37
120	TC	442	422	389	354	330	460	440	405	372	356	473	451	417	384	378	481	460	425	395	395
	SHC	177	207	255	297	327	189	225	281	336	356	200	241	309	369	378	211	258	335	395	395
	KW	44.6	44.8	44.1	45.8	45.1	45.2	45.3	45.3	45.2	45.2	45.5	45.4	45.4	45.4	45.2	45.6	45.6	45.6	45.2	45.2
	BF	0.00	0.07	0.03	0.04	0.12	0.11	0.07	0.05	0.04	0.23	0.09	0.07	0.06	0.07	0.32	0.08	0.07	0.06	0.12	0.39

48/50A040 (40 TONS) — STANDARD MODE (cont)

Temp (F) Air Entering Condenser (Edb)		Evaporator Air Quantity — Cfm														
		16,000					18,000					20,000				
		Evaporator Air — Ewb (F)														
		75	72	67	62	57	75	72	67	62	57	75	72	67	62	57
75	TC	579	555	519	483	477	587	563	526	491	491	593	569	532	504	503
	SHC	249	304	394	470	477	259	320	419	491	491	269	335	443	499	503
	KW	26.9	26.5	25.9	25.4	25.3	27.1	26.6	26.1	25.5	25.5	27.2	26.7	26.1	25.7	25.7
	BF	0.10	0.09	0.07	0.11	0.35	0.11	0.09	0.08	0.15	0.41	0.11	0.10	0.09	0.23	0.45
85	TC	560	539	503	468	464	568	546	510	479	478	574	552	515	491	489
	SHC	243	298	388	461	464	253	314	412	476	478	263	330	437	486	489
	KW	30.2	29.9	29.3	28.8	28.7	30.4	30.0	29.4	28.9	28.9	30.5	30.1	29.5	29.1	29.1
	BF	0.10	0.09	0.07	0.12	0.37	0.11	0.09	0.09	0.18	0.42	0.11	0.09	0.09	0.25	0.47
95	TC	543	522	485	451	450	551	528	492	465	463	556	534	497	477	475
	SHC	238	292	380	449	450	248	308	405	458	463	258	324	427	465	475
	KW	34.0	33.7	33.2	32.6	32.6	34.1	33.8	33.3	32.8	32.8	34.2	33.9	33.4	32.9	32.9
	BF	0.09	0.08	0.08	0.13	0.39	0.10	0.09	0.08	0.22	0.44	0.11	0.09	0.09	0.29	0.48
105	TC	523	501	464	435	434	529	507	471	450	447	534	512	475	459	458
	SHC	232	285	373	432	434	241	301	397	440	447	251	317	420	454	458
	KW	38.2	38.0	37.5	36.9	37.0	38.4	38.1	37.6	37.0	37.1	38.5	38.2	37.7	37.2	37.3
	BF	0.09	0.08	0.07	0.16	0.41	0.10	0.09	0.08	0.25	0.46	0.10	0.09	0.10	0.30	0.50
115	TC	500	479	443	420	417	505	484	449	434	429	510	489	453	440	439
	SHC	224	278	365	412	417	234	294	389	434	429	244	309	411	440	439
	KW	43.1	42.9	42.7	42.0	42.2	43.2	43.0	42.8	42.3	42.3	43.3	43.1	42.8	42.4	42.4
	BF	0.09	0.08	0.07	0.21	0.43	0.10	0.09	0.09	0.31	0.48	0.10	0.09	0.10	0.32	0.52
120	TC	488	467	432	412	408	493	473	437	425	420	497	477	442	430	430
	SHC	220	274	361	404	408	230	290	384	425	420	240	306	406	430	430
	KW	45.9	45.7	45.5	44.4	45.2	46.0	45.8	45.7	45.2	45.2	46.1	45.9	45.6	45.2	45.2
	BF	0.09	0.08	0.07	0.23	0.45	0.10	0.09	0.09	0.33	0.49	0.10	0.09	0.10	0.33	0.53

See legend on page 57.

COOLING CAPACITIES (cont)

48/50A040 (40 TONS) — SUBCOOLING MODE

Temp (F) Air Entering Condenser (Edb)		Evaporator Air Quantity – SCFM																			
		8,000					10,000					12,000					14,000				
		Evaporator Air Ewb (F)																			
		75	72	67	62	57	75	72	67	62	57	75	72	67	62	57	75	72	67	62	57
75	TC	501	473	429	379	352	528	499	455	403	374	549	519	474	420	387	562	534	488	446	408
	SHC	189	214	253	281	327	202	231	281	319	368	214	249	307	352	387	224	265	331	395	408
	kW	26.5	26.1	25.7	24.9	25.0	26.8	26.4	25.9	25.2	25.1	27.1	26.7	26.2	25.4	25.0	27.3	26.9	26.3	26.0	25.3
	BF	0.00	0.07	0.09	0.09	0.10	0.07	0.10	0.11	0.11	0.14	0.10	0.12	0.12	0.13	0.22	0.12	0.13	0.14	0.15	0.30
85	TC	478	444	410	369	330	497	477	422	382	344	523	492	440	397	363	527	498	462	424	383
	SHC	172	190	239	276	309	177	215	253	302	338	195	229	279	334	363	196	236	311	378	383
	kW	29.4	28.9	28.9	28.4	27.9	29.5	29.4	28.6	28.2	27.9	30.0	29.6	28.9	28.4	28.1	30.1	29.7	29.2	29.1	28.2
	BF	0.00	0.07	0.09	0.09	0.11	0.07	0.10	0.11	0.11	0.16	0.10	0.12	0.12	0.13	0.24	0.12	0.13	0.14	0.16	0.32
95	TC	442	416	375	348	310	476	451	398	358	332	484	457	426	386	344	506	480	437	395	363
	SHC	142	168	209	259	292	164	196	235	284	326	164	201	271	328	344	184	226	293	354	363
	kW	32.6	32.3	31.9	31.9	31.6	33.1	32.9	32.1	31.7	31.7	33.1	32.8	32.6	32.3	31.7	33.5	33.2	32.7	32.3	31.8
	BF	0.02	0.07	0.09	0.09	0.11	0.08	0.10	0.11	0.11	0.18	0.11	0.12	0.12	0.13	0.25	0.13	0.13	0.14	0.16	0.33
105	TC	415	402	363	314	288	438	413	384	347	316	464	439	400	361	325	467	449	410	374	342
	SHC	122	160	203	231	275	133	165	227	278	311	153	190	252	309	325	153	202	274	338	342
	kW	36.6	36.7	36.4	35.9	35.9	36.8	36.6	36.5	36.4	36.2	37.2	37.0	36.7	36.4	36.0	37.2	37.1	36.8	36.5	36.1
	BF	0.03	0.08	0.09	0.09	0.11	0.08	0.10	0.11	0.11	0.19	0.11	0.12	0.12	0.14	0.27	0.13	0.13	0.14	0.16	0.34
115	TC	388	376	339	304	273	410	394	356	311	295	433	410	371	324	303	445	421	383	334	330
	SHC	103	141	184	226	260	113	154	207	247	291	130	169	231	277	303	140	183	254	303	330
	kW	41.2	41.5	41.4	41.4	41.5	41.4	41.5	41.4	40.9	41.3	41.8	41.6	41.4	41.0	40.9	41.9	41.7	41.6	41.0	41.4
	BF	0.03	0.08	0.09	0.09	0.13	0.08	0.10	0.10	0.11	0.21	0.11	0.12	0.12	0.14	0.29	0.13	0.13	0.14	0.17	0.36

48/50A040 (40 TONS) — SUBCOOLING MODE (cont)

Temp (F) Air Entering Condenser (Edb)		Evaporator Air Quantity – SCFM														
		16,000					18,000					20,000				
		Evaporator Air Ewb (F)														
		75	72	67	62	57	75	72	67	62	57	75	72	67	62	57
75	TC	568	537	490	445	416	583	553	509	465	452	591	554	516	469	464
	SHC	228	272	345	410	416	243	293	377	445	452	252	300	400	465	464
	kW	27.4	26.9	26.3	25.7	25.4	27.6	27.2	26.6	26.1	25.9	27.7	27.2	26.8	26.0	26.0
	BF	0.14	0.15	0.15	0.18	0.37	0.15	0.16	0.17	0.21	0.42	0.17	0.18	0.18	0.24	0.47
85	TC	539	509	463	421	405	553	519	469	439	433	561	531	478	46	444
	SHC	206	251	325	391	405	222	266	345	422	433	231	285	368	45	444
	kW	30.2	29.8	29.2	28.7	28.5	30.5	29.9	29.2	29.2	29.1	30.6	30.1	29.4	29.2	29.2
	BF	0.14	0.15	0.15	0.18	0.38	0.16	0.16	0.17	0.22	0.43	0.17	0.18	0.18	0.25	0.48
95	TC	515	489	448	409	394	517	488	455	404	409	525	495	449	424	425
	SHC	192	239	317	384	394	194	244	338	394	409	204	257	347	423	425
	kW	33.6	33.3	32.9	32.6	32.4	33.7	33.2	32.9	32.2	32.5	33.8	33.3	32.7	32.7	32.9
	BF	0.14	0.15	0.15	0.19	0.39	0.16	0.16	0.17	0.22	0.44	0.17	0.18	0.18	0.26	0.49
105	TC	484	460	420	369	359	488	464	426	384	385	491	471	431	399	396
	SHC	169	218	297	351	359	175	229	318	374	385	179	243	337	399	396
	kW	37.5	37.2	36.9	36.2	36.1	37.5	37.2	37.0	36.4	36.6	37.5	37.3	37.0	36.8	36.7
	BF	0.14	0.15	0.15	0.19	0.41	0.16	0.16	0.17	0.24	0.46	0.17	0.18	0.18	0.28	0.50
115	TC	445	429	390	357	335	458	435	397	365	355	464	432	401	375	366
	SHC	139	195	275	339	335	153	208	296	356	355	161	212	314	375	366
	kW	41.8	41.8	41.6	41.5	40.9	42.0	41.8	41.6	41.5	41.4	42.1	41.7	41.7	41.6	41.4
	BF	0.14	0.15	0.15	0.21	0.42	0.16	0.16	0.17	0.26	0.47	0.17	0.18	0.19	0.29	0.51

See legend on page 57.

Performance data (cont)



COOLING CAPACITIES (cont)

50A040 (40 TONS) — HOT GAS REHEAT MODE

Temp (F) Air Entering Condenser (Edb)		Air Entering Evaporator — Ewb (F)													
		75 Dry Bulb							75 Dry Bulb						
		62.5 Wet Bulb (50% RH)							65.3 Wet Bulb (60% RH)						
		Air Entering Evaporator — SCFM													
		8,000	10,000	12,000	14,000	16,000	18,000	20,000	8,000	10,000	12,000	14,000	16,000	18,000	20,000
40	TC	243	259	269	277	283	288	291	259	275	286	294	300	305	308
	SHC	100	118	136	153	171	188	205	73	85	97	110	122	135	148
	KW	23.4	23.3	23.3	23.3	23.3	23.3	23.3	24.4	24.2	24.1	24.0	24.0	24.0	24.0
	BF	0.06	0.08	0.10	0.11	0.13	0.15	0.16	0.05	0.07	0.10	0.11	0.13	0.15	0.16
50	TC	224	239	249	256	262	266	270	240	255	265	273	278	283	286
	SHC	84	101	119	137	154	172	189	57	69	81	93	106	119	131
	KW	24.3	24.2	24.2	24.2	24.2	24.2	24.2	25.3	25.1	25.0	24.9	24.9	24.9	24.9
	BF	0.06	0.08	0.10	0.11	0.13	0.14	0.16	0.05	0.07	0.09	0.11	0.13	0.15	0.16
60	TC	204	217	227	234	239	243	247	219	233	243	250	256	260	263
	SHC	67	84	102	120	137	155	172	40	52	64	76	89	102	115
	KW	25.4	25.2	25.2	25.1	25.1	25.1	25.1	26.4	26.1	26.0	25.9	25.9	25.8	25.8
	BF	0.06	0.08	0.09	0.11	0.13	0.14	0.16	0.05	0.07	0.09	0.11	0.13	0.15	0.16
70	TC	184	196	205	211	216	220	223	198	211	220	227	232	235	238
	SHC	51	67	85	102	120	137	154	23	34	47	59	72	84	97
	KW	26.5	26.4	26.3	26.2	26.2	26.2	26.2	27.5	27.2	27.1	27.0	27.0	26.9	26.9
	BF	0.06	0.08	0.09	0.11	0.13	0.14	0.16	0.05	0.07	0.09	0.11	0.13	0.14	0.16
75	TC	175	186	194	200	204	208	211	188	200	209	215	220	223	226
	SHC	42	59	76	94	111	128	145	15	26	38	50	63	76	88
	KW	27.2	27.0	26.9	26.9	26.8	26.8	26.8	28.2	27.9	27.7	27.6	27.6	27.5	27.5
	BF	0.06	0.08	0.09	0.11	0.13	0.14	0.16	0.05	0.07	0.09	0.11	0.13	0.14	0.16
80	TC	165	176	183	188	193	196	199	178	189	197	203	208	211	214
	SHC	34	51	68	85	102	120	136	6	17	29	42	54	67	80
	KW	27.9	27.7	27.6	27.5	27.5	27.5	27.5	28.8	28.5	28.4	28.3	28.2	28.2	28.1
	BF	0.06	0.08	0.09	0.11	0.13	0.14	0.16	0.05	0.07	0.09	0.11	0.13	0.14	0.16

50A040 (40 TONS) — HOT GAS REHEAT MODE (cont)

Temp (F) Air Entering Condenser (Edb)		Air Entering Evaporator — Ewb (F)													
		75 Dry Bulb							75 Dry Bulb						
		68.0 Wet Bulb (70% RH)							70.5 Wet Bulb (80% RH)						
		Air Entering Evaporator — SCFM													
		8,000	10,000	12,000	14,000	16,000	18,000	20,000	8,000	10,000	12,000	14,000	16,000	18,000	20,000
40	TC	275	291	302	310	316	321	325	290	305	316	324	331	335	339
	SHC	47	53	60	68	76	84	92	20	23	26	29	33	37	42
	KW	25.5	25.1	25.0	24.9	24.8	24.8	24.7	26.5	26.1	25.8	25.7	25.6	25.5	25.4
	BF	0.02	0.05	0.08	0.10	0.13	0.14	0.16	0.00	0.00	0.02	0.06	0.09	0.11	0.13
50	TC	255	271	281	289	295	299	303	270	286	296	304	310	315	318
	SHC	30	37	44	51	59	67	76	5	7	10	13	17	21	26
	KW	26.4	26.0	25.8	25.7	25.6	25.6	25.5	27.4	26.9	26.7	26.5	26.4	26.3	26.2
	BF	0.02	0.05	0.08	0.10	0.12	0.14	0.16	0.00	0.00	0.02	0.06	0.09	0.11	0.13
60	TC	235	249	259	266	272	276	279	249	264	274	281	287	291	294
	SHC	14	20	27	34	42	51	59	-12	-10	-7	-4	0	4	9
	KW	27.4	27.0	26.8	26.7	26.6	26.5	26.5	28.4	27.9	27.6	27.4	27.3	27.2	27.2
	BF	0.02	0.05	0.08	0.10	0.12	0.14	0.16	0.00	0.00	0.03	0.06	0.09	0.11	0.13
70	TC	213	227	236	243	248	252	255	227	241	251	257	263	267	270
	SHC	-4	3	10	17	25	33	42	-29	-27	-24	-21	-17	-13	-9
	KW	28.5	28.1	27.9	27.8	27.7	27.6	27.6	29.6	29.0	28.7	28.5	28.4	28.3	28.2
	BF	0.02	0.05	0.08	0.10	0.12	0.14	0.16	0.00	0.00	0.03	0.06	0.09	0.11	0.13
75	TC	202	215	224	231	235	239	242	216	230	239	245	250	254	257
	SHC	-12	-6	1	8	16	25	33	-38	-36	-33	-30	-26	-22	-17
	KW	29.2	28.8	28.5	28.4	28.3	28.2	28.2	30.2	29.7	29.3	29.1	29.0	28.9	28.8
	BF	0.02	0.05	0.08	0.10	0.12	0.14	0.16	0.00	0.00	0.03	0.06	0.09	0.11	0.13
80	TC	191	203	212	218	223	226	229	205	218	227	233	238	241	244
	SHC	-21	-15	-8	0	8	16	24	-46	-45	-42	-39	-35	-31	-26
	KW	29.8	29.4	29.2	29.0	28.9	28.9	28.8	30.9	30.3	30.0	29.8	29.7	29.6	29.5
	BF	0.02	0.05	0.08	0.10	0.12	0.14	0.16	0.00	0.00	0.03	0.06	0.09	0.11	0.13

See legend on page 57.

COOLING CAPACITIES (cont)

48/50A050 (50 TONS) — STANDARD MODE

Temp (F) Air Entering Condenser (Edb)		Evaporator Air Quantity — Cfm														
		10,000					12,500					15,000				
		Evaporator Air — Ewb (F)														
		75	72	67	62	57	75	72	67	62	57	75	72	67	62	57
75	TC	636	602	545	495	450	669	633	575	525	489	692	658	602	550	523
	SHC	255	287	340	391	438	271	314	379	443	482	289	338	418	493	523
	kW	31.3	30.7	29.9	29.2	28.5	31.8	31.2	30.3	29.6	29.0	32.2	31.6	30.8	30.1	29.6
	BF	0.00	0.07	0.06	0.04	0.05	0.00	0.10	0.06	0.05	0.16	0.18	0.09	0.06	0.06	0.23
85	TC	611	574	524	476	432	639	605	553	504	471	662	628	576	525	503
	SHC	237	270	322	371	413	253	293	357	417	450	266	312	387	456	481
	kW	34.6	33.9	33.3	32.8	32.2	35.0	34.5	33.8	33.2	32.6	35.4	34.9	34.2	33.6	33.1
	BF	0.00	0.17	0.06	0.04	0.06	0.00	0.09	0.05	0.05	0.17	0.15	0.08	0.06	0.06	0.25
95	TC	584	553	502	454	411	613	581	530	480	450	633	601	549	499	482
	SHC	227	261	315	365	408	246	287	354	416	450	263	311	390	463	482
	kW	38.4	38.0	37.5	37.4	36.8	38.9	38.5	38.1	37.9	37.2	39.3	38.9	38.5	38.1	37.6
	BF	0.00	0.13	0.05	0.04	0.07	0.08	0.08	0.05	0.05	0.18	0.13	0.08	0.06	0.06	0.28
105	TC	559	527	477	429	393	585	553	502	453	429	603	572	519	471	459
	SHC	213	248	301	351	387	233	274	339	401	429	249	297	375	447	459
	kW	43.0	42.9	42.9	43.5	42.4	43.8	43.5	43.5	43.8	43.0	44.1	43.9	43.9	43.7	43.2
	BF	0.00	0.10	0.05	0.04	0.11	0.20	0.08	0.05	0.05	0.21	0.12	0.07	0.06	0.07	0.30
115	TC	529	498	449	402	368	554	523	472	425	406	572	540	489	442	435
	SHC	201	234	286	335	367	219	259	324	385	406	235	283	360	428	435
	kW	49.0	49.3	50.0	51.1	50.1	49.8	49.9	50.6	51.2	50.4	50.2	50.3	51.0	50.8	50.4
	BF	0.00	0.09	0.04	0.04	0.13	0.15	0.07	0.05	0.05	0.24	0.11	0.07	0.05	0.08	0.33
120	TC	514	484	435	386	357	538	507	457	409	393	555	524	472	427	421
	SHC	194	227	278	326	357	212	252	316	376	393	228	275	351	418	421
	kW	52.5	53.0	54.3	55.3	54.6	53.3	53.7	54.7	55.5	54.2	53.8	54.1	55.3	54.7	54.1
	BF	0.00	0.08	0.04	0.04	0.15	0.13	0.07	0.05	0.05	0.26	0.10	0.07	0.05	0.08	0.35

48/50A050 (50 TONS) — STANDARD MODE (cont)

Temp (F) Air Entering Condenser (Edb)		Evaporator Air Quantity — Cfm									
		17,500					20,000				
		Evaporator Air — Ewb (F)									
		75	72	67	62	57	75	72	67	62	57
75	TC	709	674	618	566	550	740	685	629	577	573
	SHC	305	361	453	537	550	326	383	486	570	573
	kW	32.4	31.9	31.0	30.3	30.0	32.6	32.1	31.2	30.4	30.3
	BF	0.13	0.08	0.06	0.08	0.31	0.12	0.08	0.07	0.12	0.37
85	TC	678	645	591	540	529	691	656	600	552	550
	SHC	276	328	413	488	499	284	341	435	504	510
	kW	35.7	35.3	34.4	33.7	33.5	35.9	35.4	34.6	33.8	33.8
	BF	0.12	0.08	0.06	0.09	0.33	0.11	0.08	0.07	0.15	0.39
95	TC	648	616	563	512	506	658	625	572	530	527
	SHC	278	334	425	501	506	292	355	457	522	527
	kW	39.6	39.2	38.8	37.9	37.9	39.8	39.3	38.9	38.0	38.1
	BF	0.11	0.08	0.06	0.10	0.35	0.10	0.08	0.07	0.18	0.41
105	TC	617	585	532	487	483	628	595	542	506	503
	SHC	264	320	409	481	483	279	341	442	499	503
	kW	44.4	44.2	44.3	43.2	43.4	44.6	44.4	44.5	43.3	43.5
	BF	0.10	0.07	0.06	0.12	0.37	0.10	0.08	0.07	0.20	0.43
115	TC	584	553	500	463	458	594	562	508	476	474
	SHC	250	305	394	451	458	265	327	425	476	474
	kW	50.6	50.7	51.4	50.1	50.4	50.8	50.9	51.7	50.4	50.2
	BF	0.10	0.07	0.06	0.17	0.40	0.09	0.07	0.07	0.22	0.46
120	TC	567	535	482	447	444	577	545	492	465	462
	SHC	243	297	385	440	444	257	319	417	459	462
	kW	54.1	54.4	55.3	53.6	54.3	54.3	54.7	56.0	53.8	54.2
	BF	0.09	0.07	0.06	0.18	0.41	0.09	0.07	0.07	0.25	0.47

See legend on page 57.

Performance data (cont)



COOLING CAPACITIES (cont)

48/50A050 (50 TONS) — SUBCOOLING MODE

Temp (F) Air Entering Condenser (Edb)		Evaporator Air Quantity – SCFM																			
		10,000					12,500					15,000					17,500				
		Evaporator Air Ewb (F)																			
		75	72	67	62	57	75	72	67	62	57	75	72	67	62	57	75	72	67	62	57
75	TC	601	568	523	479	438	624	596	547	507	471	643	608	567	521	494	651	604	582	542	524
	SHC	218	251	311	367	418	229	274	342	416	468	241	287	377	455	494	247	289	410	501	524
	KW	31.4	30.8	30.1	29.5	28.9	31.9	31.4	30.5	29.9	29.4	32.5	31.8	30.9	30.1	29.7	32.6	31.7	31.2	30.4	30.1
	BF	0.00	0.02	0.03	0.03	0.05	0.01	0.04	0.04	0.05	0.12	0.04	0.05	0.06	0.07	0.21	0.06	0.07	0.07	0.09	0.30
85	TC	567	541	498	455	417	596	570	522	481	449	620	586	540	495	472	610	599	554	510	496
	SHC	192	230	291	348	399	209	254	324	396	446	429	272	356	434	472	428	426	414	474	496
	KW	34.6	34.2	33.5	32.8	32.3	35.2	34.7	33.9	33.2	32.8	35.8	35.0	34.2	33.4	33.1	35.6	35.5	34.5	33.7	33.4
	BF	0.00	0.02	0.03	0.03	0.06	0.02	0.04	0.04	0.05	0.14	0.04	0.05	0.06	0.07	0.23	0.06	0.07	0.07	0.10	0.31
95	TC	540	513	469	428	395	565	547	495	454	426	565	555	512	470	452	591	568	524	482	477
	SHC	172	209	268	326	380	185	189	304	375	426	180	250	336	415	452	205	269	367	451	477
	KW	38.6	38.1	37.3	36.7	36.4	39.1	38.0	37.8	37.1	36.7	39.2	38.9	38.1	37.3	37.0	39.7	39.0	38.3	37.6	37.5
	BF	0.00	0.02	0.03	0.03	0.07	0.02	0.04	0.04	0.05	0.14	0.05	0.05	0.06	0.07	0.24	0.06	0.07	0.07	0.10	0.32
105	TC	512	484	444	405	378	533	506	465	424	400	548	523	482	440	423	524	535	494	455	445
	SHC	153	189	250	309	364	163	207	281	352	400	174	227	315	392	423	149	246	346	430	445
	KW	43.2	42.7	42.1	41.6	41.5	43.6	43.0	42.4	41.8	41.5	43.9	43.3	42.6	42.0	41.7	43.6	43.6	42.8	42.2	42.0
	BF	0.00	0.02	0.03	0.03	0.08	0.02	0.04	0.04	0.05	0.16	0.05	0.05	0.06	0.08	0.26	0.07	0.07	0.07	0.11	0.34
115	TC	477	454	421	385	350	500	474	432	398	377	515	489	450	413	401	533	502	459	427	421
	SHC	127	167	236	296	337	139	184	257	332	377	150	203	292	372	401	168	223	320	404	421
	KW	48.5	48.1	47.8	47.5	47.2	48.9	48.4	47.8	47.5	47.3	49.2	48.7	48.0	47.6	47.4	49.5	48.9	48.1	47.7	47.6
	BF	0.00	0.02	0.03	0.04	0.10	0.03	0.04	0.04	0.05	0.18	0.05	0.05	0.06	0.08	0.28	0.07	0.07	0.07	0.13	0.35

48/50A050 (50 TONS) — SUBCOOLING MODE (cont)

Temp (F) Air Entering Condenser (Edb)		Evaporator Air Quantity – SCFM														
		20,000					22,500					25,000				
		Evaporator Air Ewb (F)														
		75	72	67	62	57	75	72	67	62	57	75	72	67	62	57
75	TC	657	628	564	549	544	666	640	592	561	559	671	646	604	575	574
	SHC	255	320	412	530	544	267	343	460	557	559	276	360	493	575	574
	KW	32.7	32.2	31.0	30.6	30.5	32.9	32.4	31.5	30.8	30.7	33.0	32.5	31.8	31.0	31.0
	BF	0.08	0.08	0.08	0.13	0.36	0.10	0.10	0.10	0.18	0.42	0.11	0.11	0.11	0.23	0.46
85	TC	613	586	527	523	517	641	614	573	536	532	630	620	568	553	552
	SHC	428	422	409	407	406	437	430	418	409	409	433	430	416	553	552
	KW	35.7	35.2	34.1	33.9	33.8	36.4	35.8	34.8	34.1	34.1	36.1	35.8	34.7	34.4	34.4
	BF	0.08	0.08	0.08	0.13	0.37	0.10	0.10	0.10	0.19	0.43	0.11	0.11	0.12	0.25	0.47
95	TC	608	579	534	499	494	615	588	535	508	506	599	598	549	520	524
	SHC	224	289	397	486	494	236	309	419	505	506	222	329	454	520	524
	KW	39.9	39.3	38.5	37.8	37.7	40.0	39.5	38.5	38.0	38.0	39.9	39.7	38.8	38.2	38.2
	BF	0.08	0.08	0.09	0.15	0.39	0.10	0.10	0.10	0.20	0.44	0.11	0.11	0.12	0.26	0.48
105	TC	568	517	501	473	462	579	553	509	478	476	562	548	516	494	494
	SHC	194	237	374	461	462	210	284	402	478	476	198	292	430	494	494
	KW	44.3	43.3	42.9	42.4	42.2	44.5	43.9	43.0	42.5	42.5	44.3	43.9	43.2	42.7	42.7
	BF	0.08	0.08	0.09	0.16	0.40	0.10	0.10	0.10	0.21	0.45	0.11	0.11	0.12	0.28	0.49
115	TC	496	481	469	443	439	514	490	476	452	452	533	506	482	461	462
	SHC	134	211	350	432	439	155	204	378	452	452	179	231	404	461	462
	KW	49.0	48.5	48.2	47.8	47.7	49.3	48.7	48.3	47.9	47.9	49.5	48.9	48.4	48.0	48.1
	BF	0.08	0.08	0.09	0.18	0.41	0.10	0.10	0.11	0.23	0.46	0.11	0.11	0.13	0.29	0.51

See legend on page 57.

COOLING CAPACITIES (cont)

50A050 (50 TONS) — HOT GAS REHEAT MODE

Temp (F) Air Entering Condenser (Edb)		Air Entering Evaporator — Ewb (F)													
		75 Dry Bulb						75 Dry Bulb							
		62.5 Wet Bulb (50% RH)						65.3 Wet Bulb (60% RH)							
		Air Entering Evaporator — SCFM													
		10,000	12,500	15,000	17,500	20,000	22,500	25,000	10,000	12,500	15,000	17,500	20,000	22,500	25,000
40	TC	192	208	218	225	230	234	238	203	219	230	238	243	247	251
	SHC	40	67	93	118	142	166	188	-1	18	37	55	74	93	112
	kW	37.0	36.0	35.5	35.2	35.0	34.9	34.8	38.5	37.3	36.7	36.3	36.1	35.9	35.8
	BF	0.02	0.03	0.04	0.06	0.07	0.09	0.11	0.02	0.03	0.04	0.05	0.07	0.08	0.09
50	TC	197	213	223	231	236	240	243	209	226	237	244	250	254	258
	SHC	43	70	96	121	145	169	191	2	21	40	59	78	97	115
	kW	36.1	35.1	34.6	34.3	34.1	34.0	33.9	37.6	36.4	35.8	35.4	35.2	35.0	34.9
	BF	0.02	0.03	0.04	0.06	0.07	0.09	0.11	0.02	0.03	0.04	0.05	0.07	0.08	0.09
60	TC	203	219	229	237	242	246	250	214	231	242	250	255	260	263
	SHC	47	73	99	124	149	173	195	5	24	43	62	80	99	118
	kW	35.3	34.3	33.8	33.5	33.3	33.2	33.2	36.8	35.6	35.0	34.7	34.4	34.3	34.1
	BF	0.02	0.03	0.04	0.06	0.07	0.09	0.11	0.02	0.03	0.04	0.05	0.07	0.08	0.09
70	TC	212	228	239	246	252	256	259	222	240	251	259	265	270	273
	SHC	52	78	104	129	154	178	200	10	29	48	67	86	105	124
	kW	33.8	32.9	32.4	32.1	32.0	31.9	31.8	35.3	34.2	33.6	33.3	33.1	32.9	32.8
	BF	0.02	0.03	0.04	0.05	0.07	0.08	0.10	0.02	0.03	0.04	0.05	0.06	0.08	0.09
75	TC	219	235	246	254	260	265	269	230	247	259	268	275	281	285
	SHC	57	83	109	134	159	183	206	15	34	53	72	91	110	129
	kW	32.6	31.7	31.2	31.0	30.8	30.8	30.7	34.1	33.0	32.5	32.2	32.0	31.8	31.7
	BF	0.02	0.03	0.04	0.05	0.07	0.08	0.10	0.02	0.03	0.04	0.05	0.06	0.08	0.09
80	TC	225	243	255	264	271	276	280	236	256	269	279	286	292	297
	SHC	61	87	114	140	165	189	212	19	39	58	78	97	116	135
	kW	31.5	30.7	30.3	30.0	29.9	29.8	29.8	33.0	32.0	31.5	31.2	31.0	30.9	30.8
	BF	0.02	0.03	0.04	0.05	0.07	0.08	0.10	0.02	0.03	0.04	0.05	0.06	0.08	0.09

50A050 (50 TONS) — HOT GAS REHEAT MODE (cont)

Temp (F) Air Entering Condenser (Edb)		Air Entering Evaporator — Ewb (F)													
		75 Dry Bulb						75 Dry Bulb							
		68.0 Wet Bulb (70% RH)						70.5 Wet Bulb (80% RH)							
		Air Entering Evaporator — SCFM													
		10,000	12,500	15,000	17,500	20,000	22,500	25,000	10,000	12,500	15,000	17,500	20,000	22,500	25,000
40	TC	213	231	242	250	256	260	264	223	241	253	262	268	273	277
	SHC	-42	-30	-18	-6	6	18	31	-81	-76	-71	-65	-59	-52	-45
	kW	40.0	38.6	37.9	37.4	37.1	36.9	36.8	41.6	40.0	39.1	38.6	38.2	38.0	37.8
	BF	0.01	0.03	0.04	0.05	0.07	0.08	0.09	0.00	0.01	0.03	0.05	0.07	0.08	0.10
50	TC	219	237	248	257	263	267	271	229	248	260	268	275	280	284
	SHC	-39	-27	-15	-3	9	22	34	-78	-73	-68	-62	-56	-49	-42
	kW	39.1	37.8	37.0	36.6	36.3	36.1	36.0	40.7	39.1	38.3	37.8	37.4	37.1	36.9
	BF	0.01	0.03	0.04	0.05	0.07	0.08	0.09	0.00	0.01	0.03	0.05	0.07	0.08	0.10
60	TC	224	242	254	262	268	273	277	234	253	265	274	281	286	290
	SHC	-36	-24	-12	0	12	24	37	-75	-70	-65	-59	-53	-46	-40
	kW	38.3	37.0	36.3	35.8	35.5	35.3	35.2	39.9	38.3	37.5	37.0	36.6	36.4	36.2
	BF	0.01	0.03	0.04	0.05	0.07	0.08	0.09	0.00	0.01	0.03	0.05	0.07	0.08	0.10
70	TC	233	251	263	272	278	283	287	243	262	275	284	291	296	300
	SHC	-31	-19	-7	5	17	29	42	-70	-65	-60	-54	-48	-41	-35
	kW	36.8	35.5	34.9	34.5	34.2	34.0	33.9	38.4	36.9	36.1	35.6	35.3	35.0	34.9
	BF	0.01	0.03	0.04	0.05	0.07	0.08	0.09	0.00	0.01	0.03	0.05	0.07	0.08	0.10
75	TC	241	259	273	282	290	295	300	251	271	285	296	303	309	314
	SHC	-26	-15	-2	10	23	35	48	-66	-60	-55	-49	-42	-35	-28
	kW	35.6	34.4	33.8	33.4	33.1	32.9	32.8	37.3	35.8	35.0	34.5	34.2	34.0	33.8
	BF	0.01	0.03	0.04	0.05	0.07	0.08	0.09	0.00	0.01	0.03	0.05	0.07	0.08	0.10
80	TC	249	269	283	294	301	307	312	260	282	297	307	316	322	327
	SHC	-22	-9	3	16	29	41	54	-61	-55	-49	-43	-36	-29	-22
	kW	34.6	33.4	32.8	32.4	32.2	32.0	31.9	36.3	34.8	34.1	33.6	33.3	33.1	32.9
	BF	0.01	0.03	0.04	0.05	0.07	0.08	0.09	0.00	0.01	0.03	0.05	0.07	0.08	0.10

See legend on page 57.

Performance data (cont)



COOLING CAPACITIES (cont)

48/50A060 (60 TONS) — STANDARD MODE

Temp (F) Air Entering Condenser (Edb)		Evaporator Air Quantity — Cfm														
		12,000					15,000					18,000				
		Evaporator Air — Ewb (F)														
		75	72	67	62	57	75	72	67	62	57	75	72	67	62	57
75	TC	738	705	653	603	554	773	736	684	633	592	796	759	706	655	622
	SHC	293	334	406	474	533	305	361	447	530	578	324	386	486	582	622
	KW	40.0	39.2	38.1	37.1	36.3	40.7	39.9	38.7	37.7	36.9	41.2	40.4	39.2	38.2	37.5
	BF	0.00	0.00	0.10	0.08	0.08	0.00	0.15	0.10	0.09	0.19	0.23	0.13	0.11	0.10	0.25
85	TC	716	686	635	585	537	748	715	664	615	579	768	737	685	635	607
	SHC	284	327	398	465	522	298	353	439	521	562	315	378	478	572	607
	KW	44.4	43.7	42.7	41.7	40.9	45.1	44.4	43.3	42.3	41.5	45.6	44.9	43.7	42.7	42.1
	BF	0.00	0.12	0.10	0.07	0.09	0.00	0.14	0.10	0.09	0.22	0.20	0.12	0.11	0.10	0.27
95	TC	695	666	615	566	519	725	694	643	593	557	745	713	662	613	590
	SHC	276	320	389	456	510	292	346	430	511	557	308	370	469	561	590
	KW	49.5	48.8	47.8	46.9	46.1	50.2	49.5	48.4	47.5	46.8	50.7	50.0	48.8	47.9	47.4
	BF	0.00	0.19	0.09	0.07	0.10	0.00	0.13	0.09	0.09	0.20	0.18	0.12	0.10	0.10	0.29
105	TC	673	643	593	545	502	699	669	619	570	539	718	687	638	587	570
	SHC	264	311	380	446	493	283	337	420	500	539	300	361	460	549	570
	KW	55.3	54.6	53.7	52.8	51.8	55.9	55.3	54.2	53.3	52.6	56.4	55.7	54.7	53.7	53.3
	BF	0.00	0.15	0.09	0.07	0.13	0.24	0.12	0.09	0.08	0.22	0.16	0.12	0.10	0.11	0.31
115	TC	647	617	567	521	484	670	641	592	544	519	687	657	609	561	549
	SHC	255	301	369	434	474	274	327	410	488	519	290	350	448	536	549
	KW	61.7	61.1	60.3	60.0	59.2	62.3	61.7	60.9	60.4	59.9	62.8	62.2	61.3	60.6	60.2
	BF	0.00	0.13	0.08	0.07	0.17	0.18	0.11	0.09	0.08	0.25	0.14	0.11	0.10	0.11	0.34
120	TC	632	603	554	508	471	654	626	578	531	509	670	641	594	547	538
	SHC	251	296	364	428	461	269	322	404	482	509	285	345	443	528	538
	KW	65.2	64.8	64.3	64.1	63.3	65.8	65.5	64.9	64.5	64.0	66.4	65.8	65.2	64.7	64.4
	BF	0.00	0.12	0.08	0.07	0.17	0.17	0.10	0.09	0.09	0.27	0.13	0.11	0.10	0.12	0.35

48/50A060 (60 TONS) — STANDARD MODE (cont)

Temp (F) Air Entering Condenser (Edb)		Evaporator Air Quantity — Cfm														
		21,000					24,000					27,000				
		Evaporator Air — Ewb (F)														
		75	72	67	62	57	75	72	67	62	57	75	72	67	62	57
75	TC	813	776	722	671	651	826	789	735	683	674	837	800	745	695	693
	SHC	340	409	523	627	651	355	432	560	665	674	369	454	594	689	693
	KW	41.6	40.7	39.5	38.5	38.1	41.9	41.0	39.8	38.7	38.5	42.2	41.3	40.1	39.0	38.9
	BF	0.18	0.13	0.11	0.12	0.33	0.16	0.14	0.12	0.16	0.39	0.16	0.14	0.13	0.21	0.44
85	TC	784	752	700	650	634	796	764	713	662	656	806	774	723	678	675
	SHC	331	401	515	617	634	346	423	552	648	656	361	446	587	665	675
	KW	46.0	45.2	44.1	43.0	42.7	46.3	45.5	44.3	43.2	43.1	46.5	45.8	44.6	43.6	43.5
	BF	0.16	0.13	0.11	0.13	0.35	0.15	0.14	0.12	0.18	0.41	0.15	0.14	0.13	0.25	0.46
95	TC	759	728	678	627	616	770	739	689	640	638	780	748	698	659	656
	SHC	323	393	507	604	616	338	415	543	630	638	353	437	577	644	656
	KW	51.1	50.4	49.2	48.2	47.9	51.4	50.6	49.5	48.4	48.3	51.6	50.9	49.7	48.8	48.7
	BF	0.15	0.13	0.11	0.14	0.36	0.15	0.13	0.12	0.20	0.42	0.15	0.14	0.13	0.27	0.47
105	TC	731	701	651	602	596	742	711	662	620	616	750	720	670	637	634
	SHC	315	384	497	589	596	330	406	533	608	616	344	428	566	622	634
	KW	56.8	56.1	55.0	54.0	53.8	57.1	56.4	55.3	54.2	54.2	57.3	56.6	55.5	54.6	54.6
	BF	0.14	0.12	0.11	0.15	0.39	0.14	0.13	0.12	0.23	0.44	0.14	0.14	0.13	0.30	0.49
115	TC	699	670	622	576	573	709	679	631	596	592	716	687	639	612	609
	SHC	305	373	485	568	573	320	396	521	583	592	334	418	555	596	609
	KW	63.2	62.5	61.5	60.6	60.6	63.5	62.7	61.8	60.8	60.8	63.6	62.9	62.0	61.1	61.1
	BF	0.13	0.12	0.11	0.17	0.41	0.13	0.13	0.12	0.26	0.47	0.14	0.14	0.13	0.33	0.51
120	TC	682	653	607	564	561	691	662	616	584	580	698	670	623	600	595
	SHC	300	368	480	555	561	315	390	515	570	580	329	412	549	584	595
	KW	66.7	66.1	65.4	64.4	64.6	67.0	66.3	65.7	64.7	64.8	67.1	66.5	65.8	65.0	65.4
	BF	0.13	0.12	0.11	0.19	0.42	0.13	0.13	0.12	0.28	0.48	0.13	0.13	0.13	0.35	0.52

See legend on page 57.

COOLING CAPACITIES (cont)

48/50A060 (60 TONS) — SUBCOOLING MODE

Temp (F) Air Entering Condenser (Edb)		Evaporator Air Quantity – SCFM																			
		12,000					15,000					18,000					21,000				
		Evaporator Air Ewb (F)																			
		75	72	67	62	57	75	72	67	62	57	75	72	67	62	57	75	72	67	62	57
75	TC	708	671	616	563	513	742	706	649	596	549	767	732	675	620	583	787	751	693	639	613
	SHC	253	294	361	425	483	271	320	400	481	542	288	346	441	531	583	303	368	477	578	613
	kW	39.7	39.0	38.0	37.1	36.2	40.4	39.7	38.6	37.7	36.9	40.8	40.2	39.1	38.0	37.4	41.2	40.5	39.4	38.4	38.0
	BF	0.00	0.03	0.06	0.07	0.08	0.01	0.07	0.08	0.09	0.15	0.05	0.09	0.10	0.11	0.23	0.08	0.11	0.12	0.14	0.31
85	TC	676	642	588	539	492	709	675	620	568	525	730	697	643	590	556	748	714	660	607	585
	SHC	229	272	340	406	466	247	297	379	459	519	260	320	416	508	556	275	341	452	552	585
	kW	43.8	43.1	42.1	41.2	40.4	44.4	43.7	42.7	41.7	41.0	44.9	44.2	43.1	42.1	41.5	45.2	44.5	43.5	42.4	42.0
	BF	0.00	0.04	0.06	0.07	0.09	0.02	0.07	0.08	0.09	0.16	0.06	0.09	0.10	0.11	0.24	0.09	0.11	0.12	0.14	0.32
95	TC	643	608	559	511	464	674	641	589	539	500	695	663	610	560	531	711	679	626	576	556
	SHC	205	245	317	384	445	220	271	356	437	494	235	294	392	485	531	249	316	427	528	556
	kW	48.4	47.7	46.7	45.8	45.0	49.0	48.3	47.3	46.3	45.6	49.5	48.8	47.7	46.7	46.2	49.8	49.1	48.0	47.0	46.6
	BF	0.00	0.04	0.06	0.07	0.08	0.02	0.07	0.08	0.09	0.17	0.06	0.09	0.10	0.11	0.26	0.09	0.11	0.12	0.14	0.33
105	TC	609	574	528	481	439	636	606	556	508	473	654	625	575	527	501	671	640	590	543	526
	SHC	179	220	294	362	420	193	245	331	413	469	205	267	366	459	501	219	288	401	501	526
	kW	53.6	52.8	51.9	51.0	50.2	54.2	53.5	52.5	51.5	50.8	54.6	54.0	52.9	51.9	51.4	55.0	54.3	53.2	52.2	51.9
	BF	0.00	0.04	0.06	0.07	0.10	0.03	0.07	0.08	0.09	0.18	0.07	0.09	0.10	0.11	0.27	0.09	0.11	0.11	0.15	0.35
115	TC	571	538	494	450	413	594	566	519	474	443	614	585	538	492	470	628	599	551	506	494
	SHC	153	193	268	338	395	162	217	304	387	443	177	238	339	433	470	189	259	373	472	494
	kW	59.4	58.7	57.8	56.9	56.1	59.9	59.3	58.3	57.4	56.7	60.4	59.7	58.7	57.7	57.3	60.7	60.0	59.0	58.0	57.8
	BF	0.01	0.05	0.06	0.07	0.12	0.04	0.07	0.08	0.09	0.19	0.07	0.09	0.10	0.12	0.29	0.09	0.11	0.11	0.15	0.36

48/50A060 (60 TONS) — SUBCOOLING MODE (cont)

Temp (F) Air Entering Condenser (Edb)		Evaporator Air Quantity – SCFM														
		24,000					27,000					30,000				
		Evaporator Air Ewb (F)														
		75	72	67	62	57	75	72	67	62	57	75	72	67	62	57
75	TC	804	768	708	654	637	814	779	720	665	657	825	789	729	678	674
	SHC	320	392	512	618	637	332	413	546	652	657	346	434	578	678	674
	kW	41.5	40.9	39.7	38.7	38.4	41.8	41.1	39.9	38.9	38.8	42.0	41.3	40.1	39.2	39.1
	BF	0.11	0.13	0.13	0.17	0.38	0.12	0.14	0.15	0.20	0.43	0.14	0.16	0.16	0.24	0.47
85	TC	761	729	674	621	607	772	740	684	634	627	783	749	693	647	646
	SHC	289	364	487	591	607	302	385	520	621	627	317	406	552	647	646
	kW	45.5	44.8	43.7	42.7	42.5	45.7	45.1	43.9	43.0	42.8	46.0	45.3	44.1	43.2	43.2
	BF	0.11	0.13	0.13	0.17	0.39	0.13	0.14	0.15	0.21	0.44	0.14	0.16	0.16	0.26	0.48
95	TC	722	691	639	589	578	734	702	647	599	597	742	709	656	612	613
	SHC	260	337	461	565	578	275	358	492	588	597	287	377	524	612	613
	kW	50.1	49.4	48.3	47.3	47.1	50.3	49.6	48.5	47.5	47.4	50.5	49.8	48.6	47.7	47.8
	BF	0.11	0.13	0.13	0.17	0.40	0.13	0.14	0.15	0.23	0.45	0.14	0.15	0.16	0.27	0.49
105	TC	682	651	601	556	547	692	661	608	569	565	700	669	618	582	580
	SHC	232	308	434	533	547	245	328	464	559	565	258	349	496	582	580
	kW	55.3	54.5	53.4	52.5	52.3	55.5	54.8	53.6	52.7	52.7	55.7	54.9	53.8	53.0	53.0
	BF	0.11	0.12	0.13	0.19	0.41	0.13	0.14	0.15	0.24	0.46	0.14	0.15	0.16	0.29	0.50
115	TC	639	610	562	521	514	647	618	570	535	531	655	625	575	546	545
	SHC	202	279	406	501	514	214	299	437	527	531	226	318	464	546	545
	kW	61.0	60.3	59.2	58.3	58.2	61.2	60.5	59.4	58.6	58.5	61.4	60.7	59.5	58.8	58.8
	BF	0.11	0.12	0.13	0.21	0.42	0.13	0.14	0.15	0.25	0.47	0.14	0.15	0.17	0.30	0.51

See legend on page 57.

Performance data (cont)



COOLING CAPACITIES (cont)

50A060 (60 TONS) — HOT GAS REHEAT MODE

Temp (F) Air Entering Condenser (Edb)		Air Entering Evaporator — Ewb (F)													
		75 Dry Bulb							75 Dry Bulb						
		62.5 Wet Bulb (50% RH)							65.3 Wet Bulb (60% RH)						
		Air Entering Evaporator — SCFM													
		12,000	15,000	18,000	21,000	24,000	27,000	30,000	12,000	15,000	18,000	21,000	24,000	27,000	30,000
40	TC	298	322	339	352	362	369	375	314	339	357	370	380	388	395
	SHC	80	111	141	171	201	230	258	30	52	74	97	119	141	163
	KW	36.2	36.0	36.0	36.1	36.1	36.2	36.3	37.8	37.5	37.4	37.4	37.4	37.5	37.5
	BF	0.04	0.06	0.07	0.08	0.09	0.11	0.12	0.03	0.05	0.07	0.08	0.09	0.10	0.12
50	TC	287	308	324	336	345	351	357	301	325	341	353	363	370	376
	SHC	74	104	134	164	194	223	250	24	46	68	90	112	134	156
	KW	37.7	37.5	37.4	37.4	37.5	37.5	37.6	39.3	38.9	38.8	38.8	38.8	38.8	38.8
	BF	0.04	0.06	0.07	0.08	0.09	0.11	0.12	0.04	0.05	0.07	0.08	0.09	0.10	0.12
60	TC	277	297	311	320	328	335	340	291	311	326	337	346	352	358
	SHC	70	99	128	157	187	216	243	19	40	61	83	105	127	149
	KW	39.4	39.1	39.0	39.0	39.0	39.0	39.1	40.9	40.5	40.3	40.3	40.3	40.3	40.3
	BF	0.04	0.06	0.07	0.08	0.09	0.11	0.12	0.04	0.05	0.07	0.08	0.09	0.10	0.11
70	TC	267	287	299	309	316	321	325	280	300	314	324	331	336	341
	SHC	65	94	123	153	182	210	237	15	35	56	78	100	121	143
	KW	41.2	40.9	40.8	40.7	40.7	40.7	40.8	42.7	42.3	42.1	42.0	42.0	42.0	42.0
	BF	0.04	0.06	0.07	0.08	0.09	0.11	0.12	0.04	0.05	0.07	0.08	0.09	0.10	0.11
75	TC	262	281	294	303	309	314	319	275	295	308	317	324	330	334
	SHC	62	92	121	150	180	207	234	12	33	54	75	97	119	141
	KW	42.2	41.9	41.7	41.7	41.7	41.7	41.7	43.7	43.3	43.1	43.0	43.0	42.9	42.9
	BF	0.04	0.06	0.07	0.08	0.09	0.11	0.13	0.04	0.05	0.07	0.08	0.09	0.10	0.11
80	TC	257	275	288	296	303	308	312	270	289	302	311	318	323	327
	SHC	60	89	118	148	177	205	232	10	30	51	73	95	116	138
	KW	43.3	42.9	42.8	42.7	42.7	42.7	42.7	44.8	44.3	44.1	44.0	44.0	44.0	43.9
	BF	0.04	0.06	0.07	0.08	0.09	0.11	0.13	0.04	0.05	0.07	0.08	0.09	0.10	0.11

50A060 (60 TONS) — HOT GAS REHEAT MODE (cont)

Temp (F) Air Entering Condenser (Edb)		Air Entering Evaporator — Ewb (F)													
		75 Dry Bulb							75 Dry Bulb						
		68.0 Wet Bulb (70% RH)							70.5 Wet Bulb (80% RH)						
		Air Entering Evaporator — SCFM													
		12,000	15,000	18,000	21,000	24,000	27,000	30,000	12,000	15,000	18,000	21,000	24,000	27,000	30,000
40	TC	330	357	375	389	400	408	414	345	373	393	407	418	426	433
	SHC	-19	-5	10	24	39	54	69	-65	-58	-51	-43	-35	-27	-18
	KW	39.4	39.0	38.8	38.8	38.8	38.7	38.8	41.0	40.4	40.2	40.0	40.0	39.9	39.9
	BF	0.02	0.04	0.06	0.07	0.09	0.10	0.11	0.00	0.01	0.03	0.05	0.07	0.09	0.10
50	TC	316	341	359	372	381	389	395	331	358	376	389	399	407	413
	SHC	-25	-11	3	18	32	48	63	-72	-64	-57	-50	-42	-33	-25
	KW	40.9	40.4	40.2	40.1	40.1	40.1	40.1	42.5	41.8	41.5	41.4	41.3	41.2	41.2
	BF	0.02	0.04	0.06	0.07	0.09	0.10	0.11	0.00	0.01	0.03	0.05	0.07	0.09	0.10
60	TC	304	326	342	354	363	370	376	318	342	358	371	380	387	393
	SHC	-30	-17	-3	11	26	41	56	-77	-71	-64	-56	-48	-40	-31
	KW	42.5	42.0	41.7	41.6	41.6	41.5	41.5	44.1	43.4	43.1	42.9	42.8	42.7	42.6
	BF	0.02	0.04	0.06	0.07	0.09	0.10	0.11	0.00	0.01	0.03	0.05	0.07	0.09	0.10
70	TC	294	315	329	339	347	353	357	307	329	343	354	363	369	374
	SHC	-35	-22	-9	5	20	35	49	-82	-75	-69	-62	-54	-46	-37
	KW	44.3	43.8	43.5	43.3	43.3	43.2	43.2	45.9	45.2	44.8	44.6	44.5	44.4	44.3
	BF	0.02	0.04	0.06	0.07	0.09	0.10	0.11	0.00	0.01	0.03	0.05	0.07	0.09	0.10
75	TC	288	309	323	332	340	346	350	301	323	337	348	356	362	367
	SHC	-37	-24	-11	3	18	32	47	-84	-78	-71	-64	-56	-48	-40
	KW	45.3	44.7	44.5	44.3	44.2	44.2	44.1	46.9	46.1	45.7	45.5	45.4	45.3	45.3
	BF	0.02	0.04	0.06	0.07	0.09	0.10	0.11	0.00	0.01	0.03	0.05	0.07	0.09	0.10
80	TC	283	303	316	326	333	339	343	295	316	330	341	348	355	360
	SHC	-39	-27	-13	1	15	30	44	-86	-80	-74	-67	-59	-50	-42
	KW	46.4	45.8	45.5	45.3	45.2	45.2	45.1	47.9	47.2	46.8	46.6	46.4	46.3	46.3
	BF	0.02	0.04	0.06	0.07	0.09	0.10	0.11	0.00	0.01	0.03	0.05	0.07	0.09	0.10

See legend on page 57.

FAN PERFORMANCE — VERTICAL DISCHARGE UNITS

48A2,A3 020 (20 TONS)

Airflow (Cfm)	Available External Static Pressure (in. wg)																			
	0.2		0.4		0.6		0.8		1.0		1.2		1.4		1.6		1.8		2.0	
	Rpm	Bhp	Rpm	Bhp	Rpm	Bhp	Rpm	Bhp	Rpm	Bhp	Rpm	Bhp	Rpm	Bhp	Rpm	Bhp	Rpm	Bhp	Rpm	Bhp
4,000	328	0.62	406	0.84	472	1.07	529	1.30	580	1.54	626	1.78	668	2.02	708	2.27	745	2.51	780	2.76
5,000	369	0.97	439	1.19	500	1.43	554	1.69	604	1.95	650	2.21	692	2.48	731	2.74	769	3.01	804	3.28
6,000	415	1.43	477	1.65	533	1.90	584	2.17	631	2.45	676	2.73	717	3.01	756	3.30	793	3.59	828	3.88
7,000	463	2.01	519	2.25	570	2.50	618	2.78	662	3.06	704	3.36	744	3.65	782	3.96	818	4.27	852	4.58
7,500	488	2.36	541	2.60	590	2.86	636	3.13	679	3.42	720	3.72	759	4.02	796	4.33	832	4.65	866	4.96
8,000	513	2.74	564	2.98	611	3.24	655	3.52	697	3.81	737	4.11	775	4.42	811	4.74	846	5.06	879	5.38
9,000	564	3.61	612	3.87	655	4.13	696	4.42	735	4.71	772	5.02	808	5.33	843	5.65	876	5.98	909	6.32
10,000	616	4.64	661	4.91	701	5.18	739	5.47	776	5.77	811	6.08	845	6.40	878	6.72	909	7.06	940	7.40

48A2,A3 020 (20 TONS) (cont)

Airflow (Cfm)	Available External Static Pressure (in. wg)																			
	2.2		2.4		2.6		2.8		3.0		3.2		3.4		3.6		3.8		4.0	
	Rpm	Bhp	Rpm	Bhp	Rpm	Bhp	Rpm	Bhp	Rpm	Bhp	Rpm	Bhp	Rpm	Bhp	Rpm	Bhp	Rpm	Bhp	Rpm	Bhp
4,000	814	3.01	845	3.26	876	3.51	905	3.76	934	4.02	961	4.28	987	4.54	1013	4.80	1038	5.06	1062	5.32
5,000	837	3.55	869	3.82	900	4.10	929	4.37	958	4.64	985	4.92	1012	5.20	1038	5.48	1063	5.76	1087	6.04
6,000	861	4.17	893	4.46	923	4.76	953	5.05	981	5.35	1009	5.65	1036	5.94	1062	6.24	1087	6.54	1111	6.84
7,000	885	4.89	917	5.20	947	5.51	977	5.83	1005	6.14	1033	6.46	1059	6.78	1085	7.09	1110	7.41	1135	7.73
7,500	898	5.28	930	5.61	960	5.93	989	6.25	1017	6.58	1045	6.90	1071	7.23	1097	7.56	1122	7.88	1147	8.21
8,000	912	5.71	943	6.04	973	6.37	1002	6.70	1030	7.04	1057	7.37	1083	7.71	1109	8.04	1134	8.38	1159	8.72
9,000	940	6.66	970	7.00	999	7.35	1028	7.69	1055	8.04	1082	8.39	1109	8.75	1134	9.10	1159	9.45	1183	9.81
10,000	971	7.75	1000	8.10	1028	8.46	1056	8.82	1083	9.18	1109	9.54	1135	9.91	1160	10.28	1185	10.65	—	—

48A2,A3 025-030 (25 THRU 30 TONS)

Airflow (Cfm)	Available External Static Pressure (in. wg)																			
	0.2		0.4		0.6		0.8		1.0		1.2		1.4		1.6		1.8		2.0	
	Rpm	Bhp	Rpm	Bhp	Rpm	Bhp	Rpm	Bhp	Rpm	Bhp	Rpm	Bhp	Rpm	Bhp	Rpm	Bhp	Rpm	Bhp	Rpm	Bhp
5,000	374	0.98	443	1.20	503	1.45	558	1.70	607	1.96	653	2.23	695	2.49	734	2.76	771	3.03	806	3.30
6,000	421	1.45	482	1.68	538	1.93	589	2.20	636	2.47	680	2.75	721	3.04	759	3.33	796	3.62	831	3.91
7,000	471	2.04	526	2.28	576	2.54	623	2.81	668	3.10	710	3.39	749	3.69	787	4.00	823	4.31	857	4.62
8,000	522	2.78	572	3.03	619	3.29	662	3.57	704	3.86	743	4.16	781	4.47	817	4.79	851	5.11	885	5.44
9,000	574	3.66	621	3.92	664	4.19	704	4.47	743	4.77	780	5.08	815	5.40	850	5.72	883	6.05	915	6.39
10,000	628	4.71	671	4.97	711	5.25	748	5.54	784	5.84	819	6.15	853	6.47	885	6.81	917	7.14	948	7.49
11,000	682	5.91	722	6.19	759	6.48	795	6.77	828	7.08	861	7.40	893	7.72	924	8.06	954	8.40	983	8.75
12,000	736	7.30	774	7.59	809	7.88	842	8.18	874	8.49	905	8.82	935	9.15	965	9.48	993	9.83	1021	10.19
13,000	791	8.86	827	9.16	860	9.46	891	9.78	922	10.09	951	10.42	979	10.75	1007	11.10	1034	11.45	1061	11.80
14,000	846	10.61	880	10.93	912	11.24	941	11.56	970	11.88	998	12.21	1025	12.56	1052	12.90	1078	13.26	1103	13.62
15,000	902	12.56	934	12.89	964	13.21	992	13.54	1020	13.87	1046	14.21	1072	14.55	1098	14.91	1122	15.26	1147	15.63

48A2,A3 025-030 (25 THRU 30 TONS) (cont)

Airflow (Cfm)	Available External Static Pressure (in. wg)																			
	2.2		2.4		2.6		2.8		3.0		3.2		3.4		3.6		3.8		4.0	
	Rpm	Bhp	Rpm	Bhp	Rpm	Bhp	Rpm	Bhp	Rpm	Bhp	Rpm	Bhp	Rpm	Bhp	Rpm	Bhp	Rpm	Bhp	Rpm	Bhp
5,000	839	3.57	871	3.84	902	4.11	931	4.39	960	4.66	987	4.94	1014	5.22	1039	5.50	1064	5.78	1089	6.06
6,000	864	4.20	896	4.49	926	4.79	956	5.08	984	5.38	1012	5.68	1038	5.97	1064	6.27	1089	6.57	1114	6.87
7,000	890	4.93	921	5.24	951	5.55	980	5.87	1009	6.18	1036	6.50	1063	6.82	1088	7.14	1114	7.45	1138	7.77
8,000	917	5.76	948	6.09	977	6.42	1006	6.76	1034	7.09	1061	7.43	1088	7.76	1113	8.10	1138	8.43	1163	8.77
9,000	946	6.73	976	7.07	1005	7.42	1033	7.76	1061	8.11	1088	8.46	1114	8.82	1139	9.17	1164	9.52	1188	9.88
10,000	978	7.84	1007	8.19	1035	8.55	1063	8.91	1089	9.27	1116	9.63	1141	10.00	1166	10.37	1191	10.74	—	—
11,000	1012	9.10	1040	9.47	1067	9.83	1094	10.20	1120	10.57	1145	10.95	1170	11.33	1195	11.71	—	—	—	—
12,000	1048	10.54	1075	10.91	1102	11.28	1127	11.66	1152	12.04	1177	12.42	—	—	—	—	—	—	—	—
13,000	1087	12.17	1113	12.54	1138	12.91	1163	13.30	1187	13.68	—	—	—	—	—	—	—	—	—	—
14,000	1128	13.98	1153	14.36	1177	14.74	—	—	—	—	—	—	—	—	—	—	—	—	—	—
15,000	1171	16.00	1194	16.38	—	—	—	—	—	—	—	—	—	—	—	—	—	—	—	—

LEGEND

Bhp — Brake Horsepower

NOTES:

- Fan performance is based on wet coils, economizer, roof curb, cabinet losses, and clean 2-in. filters.
- Conversion — Bhp to watts:

$$\text{Watts} = \frac{\text{Bhp} \times 746}{\text{Motor efficiency}}$$

- Variable air volume units will operate down to 70 cfm/ton. Performance at 70 cfm/ton is limited to unloaded operation and may be additionally limited by edb and ewb conditions or Humidi-MiZer operation.

Performance data (cont)



FAN PERFORMANCE — VERTICAL DISCHARGE UNITS (cont)

50A2,A3 020 (20 TONS)

Airflow (Cfm)	Available External Static Pressure (in. wg)																			
	0.2		0.4		0.6		0.8		1.0		1.2		1.4		1.6		1.8		2.0	
	Rpm	Bhp	Rpm	Bhp	Rpm	Bhp	Rpm	Bhp	Rpm	Bhp	Rpm	Bhp	Rpm	Bhp	Rpm	Bhp	Rpm	Bhp	Rpm	Bhp
4,000	311	0.54	390	0.71	457	0.88	515	1.05	567	1.21	613	1.38	656	1.55	696	1.71	733	1.88	768	2.04
5,000	347	0.84	417	1.02	480	1.21	536	1.40	587	1.59	633	1.78	676	1.97	716	2.16	753	2.34	788	2.52
6,000	387	1.25	450	1.43	507	1.63	560	1.84	609	2.05	654	2.26	696	2.47	735	2.68	773	2.88	808	3.09
7,000	430	1.77	488	1.96	540	2.17	588	2.38	634	2.61	677	2.83	718	3.06	756	3.29	793	3.51	828	3.74
7,500	452	2.07	507	2.27	557	2.48	604	2.70	648	2.93	690	3.16	730	3.40	768	3.63	804	3.87	839	4.10
8,000	474	2.41	528	2.61	576	2.82	620	3.04	663	3.28	704	3.52	743	3.76	780	4.00	816	4.24	850	4.48
9,000	519	3.19	570	3.39	614	3.60	656	3.83	696	4.07	734	4.32	771	4.57	806	4.82	840	5.08	873	5.34
10,000	565	4.10	613	4.31	655	4.53	694	4.76	731	5.00	767	5.26	802	5.51	835	5.78	868	6.04	900	6.31

50A2,A3 020 (20 TONS) (cont)

Airflow (Cfm)	Available External Static Pressure (in. wg)																			
	2.2		2.4		2.6		2.8		3.0		3.2		3.4		3.6		3.8		4.0	
	Rpm	Bhp	Rpm	Bhp	Rpm	Bhp	Rpm	Bhp	Rpm	Bhp	Rpm	Bhp	Rpm	Bhp	Rpm	Bhp	Rpm	Bhp	Rpm	Bhp
4,000	802	2.21	833	2.38	864	2.55	893	2.71	921	2.88	949	3.06	975	3.23	1001	3.40	1026	3.58	1050	3.75
5,000	822	2.71	854	2.89	885	3.08	914	3.26	943	3.45	970	3.64	997	3.82	1023	4.01	1048	4.20	1072	4.39
6,000	842	3.29	874	3.50	905	3.70	934	3.90	963	4.10	991	4.31	1017	4.51	1043	4.71	1069	4.91	1093	5.12
7,000	862	3.96	894	4.19	924	4.41	954	4.63	983	4.85	1010	5.07	1037	5.29	1063	5.51	1089	5.72	1113	5.94
7,500	872	4.33	904	4.56	934	4.79	964	5.02	993	5.25	1020	5.48	1047	5.71	1073	5.94	1099	6.16	1123	6.39
8,000	883	4.73	914	4.97	945	5.21	974	5.45	1003	5.68	1030	5.92	1057	6.16	1083	6.39	1108	6.63	1133	6.87
9,000	905	5.60	936	5.85	966	6.11	995	6.37	1023	6.62	1051	6.88	1077	7.13	1103	7.38	1129	7.64	1153	7.89
10,000	931	6.58	961	6.85	990	7.13	1018	7.40	1046	7.67	1073	7.94	1099	8.21	1124	8.48	1149	8.75	1174	9.02

50A2,A3 025-030 (25 THRU 30 TONS)

Airflow (Cfm)	Available External Static Pressure (in. wg)																			
	0.2		0.4		0.6		0.8		1.0		1.2		1.4		1.6		1.8		2.0	
	Rpm	Bhp	Rpm	Bhp	Rpm	Bhp	Rpm	Bhp	Rpm	Bhp	Rpm	Bhp	Rpm	Bhp	Rpm	Bhp	Rpm	Bhp	Rpm	Bhp
5,000	352	0.85	422	1.03	484	1.22	540	1.42	590	1.61	636	1.79	678	1.98	718	2.17	755	2.35	791	2.54
6,000	394	1.26	456	1.45	513	1.65	565	1.86	613	2.07	658	2.28	700	2.49	739	2.70	776	2.90	811	3.11
7,000	438	1.79	495	1.98	546	2.19	594	2.41	640	2.64	682	2.86	723	3.09	761	3.32	798	3.54	833	3.77
8,000	483	2.44	536	2.64	583	2.85	628	3.08	670	3.32	710	3.55	749	3.80	786	4.04	821	4.28	855	4.52
9,000	530	3.23	579	3.43	623	3.65	664	3.88	704	4.12	741	4.37	778	4.62	813	4.88	847	5.13	880	5.39
10,000	577	4.15	624	4.36	665	4.58	703	4.82	740	5.06	776	5.32	810	5.58	843	5.84	876	6.11	907	6.38
11,000	625	5.22	669	5.44	708	5.67	744	5.91	779	6.16	813	6.41	845	6.68	877	6.95	907	7.22	937	7.50
12,000	674	6.45	715	6.67	753	6.90	787	7.15	820	7.40	851	7.67	882	7.93	912	8.21	941	8.49	970	8.78
13,000	722	7.85	762	8.07	798	8.30	831	8.55	862	8.81	892	9.08	921	9.35	950	9.63	977	9.92	1005	10.21
14,000	771	9.41	810	9.64	844	9.88	875	10.13	905	10.39	934	10.66	962	10.94	989	11.22	1015	11.51	1041	11.81
15,000	821	11.15	857	11.38	890	11.62	921	11.88	949	12.14	977	12.42	1004	12.70	1030	12.99	1055	13.28	1080	13.58

50A2,A3 025-030 (25 THRU 30 TONS) (cont)

Airflow (Cfm)	Available External Static Pressure (in. wg)																			
	2.2		2.4		2.6		2.8		3.0		3.2		3.4		3.6		3.8		4.0	
	Rpm	Bhp	Rpm	Bhp	Rpm	Bhp	Rpm	Bhp	Rpm	Bhp	Rpm	Bhp	Rpm	Bhp	Rpm	Bhp	Rpm	Bhp	Rpm	Bhp
5,000	824	2.72	856	2.91	887	3.09	916	3.28	945	3.46	972	3.65	999	3.83	1024	4.02	1049	4.21	1074	4.40
6,000	845	3.31	877	3.52	908	3.72	937	3.92	966	4.12	993	4.32	1020	4.53	1046	4.73	1071	4.93	1096	5.14
7,000	866	3.99	898	4.21	928	4.43	958	4.66	986	4.88	1014	5.10	1041	5.31	1067	5.53	1092	5.75	1116	5.97
8,000	888	4.77	919	5.01	950	5.25	979	5.49	1007	5.72	1035	5.96	1061	6.20	1087	6.43	1113	6.67	1137	6.90
9,000	912	5.65	942	5.90	972	6.16	1001	6.42	1029	6.67	1056	6.93	1083	7.18	1108	7.43	1134	7.69	1158	7.94
10,000	938	6.65	968	6.92	997	7.19	1025	7.46	1052	7.73	1079	8.00	1105	8.27	1130	8.54	1155	8.81	1180	9.08
11,000	967	7.78	995	8.07	1023	8.35	1051	8.63	1077	8.92	1103	9.20	1129	9.49	1154	9.77	1178	10.06	—	—
12,000	998	9.07	1025	9.35	1052	9.65	1078	9.94	1104	10.24	1130	10.54	1154	10.83	1179	11.13	—	—	—	—
13,000	1031	10.50	1058	10.80	1083	11.10	1109	11.40	1133	11.71	1158	12.01	1182	12.32	—	—	—	—	—	—
14,000	1067	12.10	1092	12.41	1117	12.71	1141	13.02	1165	13.33	1188	13.65	—	—	—	—	—	—	—	—
15,000	1104	13.88	1128	14.19	1152	14.50	1175	14.81	1198	15.13	—	—	—	—	—	—	—	—	—	—

LEGEND

Bhp — Brake Horsepower

NOTES:

- Fan performance is based on wet coils, economizer, roof curb, cabinet losses, and clean 2-in. filters.
- Conversion — Bhp to watts:

$$\text{Watts} = \frac{\text{Bhp} \times 746}{\text{Motor efficiency}}$$

- Variable air volume units will operate down to 70 cfm/ton. Performance at 70 cfm/ton is limited to unloaded operation and may be additionally limited by edb and ewb conditions or Humidi-MiZer operation.

FAN PERFORMANCE — HORIZONTAL DISCHARGE UNITS

48A4,A5 020 (20 TONS)

Airflow (Cfm)	Available External Static Pressure (in. wg)																			
	0.2		0.4		0.6		0.8		1.0		1.2		1.4		1.6		1.8		2.0	
	Rpm	Bhp	Rpm	Bhp	Rpm	Bhp	Rpm	Bhp	Rpm	Bhp	Rpm	Bhp	Rpm	Bhp	Rpm	Bhp	Rpm	Bhp	Rpm	Bhp
4,000	339	0.71	414	0.97	478	1.25	534	1.54	585	1.84	631	2.14	674	2.44	714	2.75	751	3.06	787	3.37
5,000	384	1.10	452	1.37	510	1.66	563	1.96	611	2.28	656	2.60	698	2.93	738	3.27	775	3.60	811	3.94
6,000	433	1.61	494	1.89	548	2.19	597	2.51	643	2.84	686	3.18	726	3.52	764	3.88	800	4.23	835	4.60
7,000	484	2.27	540	2.56	590	2.87	636	3.19	679	3.53	719	3.88	757	4.24	794	4.61	829	4.98	863	5.36
7,500	511	2.66	563	2.95	612	3.26	656	3.59	698	3.94	737	4.29	775	4.66	810	5.03	845	5.41	877	5.79
8,000	538	3.09	588	3.38	634	3.70	678	4.03	718	4.38	756	4.74	793	5.11	827	5.49	861	5.87	893	6.26
9,000	593	4.07	639	4.37	682	4.69	722	5.03	760	5.39	796	5.76	831	6.13	864	6.52	896	6.91	927	7.32
10,000	649	5.23	691	5.54	731	5.87	769	6.21	805	6.58	839	6.95	872	7.34	904	7.73	934	8.13	964	8.54

48A4,A5 020 (20 TONS) (cont)

Airflow (Cfm)	Available External Static Pressure (in. wg)																			
	2.2		2.4		2.6		2.8		3.0		3.2		3.4		3.6		3.8		4.0	
	Rpm	Bhp	Rpm	Bhp	Rpm	Bhp	Rpm	Bhp	Rpm	Bhp	Rpm	Bhp	Rpm	Bhp	Rpm	Bhp	Rpm	Bhp	Rpm	Bhp
4,000	820	3.68	852	3.99	883	4.30	912	4.62	940	4.93	967	5.25	993	5.57	1019	5.89	1043	6.21	1067	6.53
5,000	844	4.28	877	4.63	907	4.97	937	5.31	966	5.66	993	6.01	1020	6.35	1046	6.70	1071	7.05	1095	7.40
6,000	869	4.96	901	5.33	931	5.70	961	6.07	990	6.44	1017	6.81	1044	7.19	1070	7.57	1096	7.94	1121	8.32
7,000	895	5.74	926	6.13	956	6.52	986	6.91	1014	7.30	1042	7.70	1068	8.10	1094	8.50	1120	8.90	1145	9.30
7,500	909	6.18	940	6.57	970	6.97	999	7.37	1027	7.78	1054	8.18	1081	8.59	1107	9.00	1132	9.41	1157	9.82
8,000	925	6.66	955	7.06	984	7.46	1013	7.87	1040	8.28	1067	8.69	1094	9.11	1119	9.53	1144	9.95	1169	10.37
9,000	957	7.72	986	8.13	1015	8.55	1042	8.97	1069	9.39	1096	9.82	1121	10.25	1146	10.69	1171	11.12	1195	11.56
10,000	993	8.96	1021	9.38	1048	9.80	1075	10.23	1101	10.67	1126	11.11	1151	11.55	1176	12.00	1200	12.45	—	—

48A4,A5 025-030 (25 THRU 30 TONS)

Airflow (Cfm)	Available External Static Pressure (in. wg)																			
	0.2		0.4		0.6		0.8		1.0		1.2		1.4		1.6		1.8		2.0	
	Rpm	Bhp	Rpm	Bhp	Rpm	Bhp	Rpm	Bhp	Rpm	Bhp	Rpm	Bhp	Rpm	Bhp	Rpm	Bhp	Rpm	Bhp	Rpm	Bhp
5,000	389	1.11	456	1.38	514	1.68	566	1.98	614	2.30	659	2.62	701	2.95	740	3.29	777	3.62	813	3.96
6,000	439	1.64	499	1.92	553	2.22	602	2.54	647	2.87	689	3.21	730	3.56	768	3.91	804	4.27	838	4.63
7,000	492	2.31	546	2.60	596	2.91	641	3.24	684	3.58	724	3.93	762	4.29	798	4.66	833	5.03	867	5.41
8,000	546	3.14	596	3.43	642	3.75	684	4.09	724	4.44	762	4.80	798	5.17	833	5.55	866	5.93	898	6.32
9,000	602	4.13	647	4.43	690	4.76	730	5.10	768	5.46	803	5.83	838	6.21	871	6.60	903	7.00	933	7.40
10,000	659	5.31	701	5.62	740	5.95	777	6.30	813	6.67	847	7.04	880	7.43	911	7.83	942	8.23	971	8.64
11,000	717	6.67	755	6.99	792	7.33	827	7.68	860	8.06	893	8.44	924	8.83	954	9.24	983	9.65	1011	10.07
12,000	775	8.23	811	8.56	845	8.90	878	9.27	909	9.64	940	10.03	970	10.43	999	10.84	1026	11.26	1054	11.69
13,000	834	9.99	867	10.33	899	10.68	930	11.05	960	11.44	989	11.83	1017	12.24	1045	12.65	1072	13.08	1098	13.51
14,000	893	11.97	924	12.32	954	12.68	983	13.06	1012	13.44	1039	13.85	1066	14.26	1093	14.68	1118	15.11	1143	15.54
15,000	953	14.17	982	14.53	1010	14.90	1037	15.28	1064	15.68	1091	16.08	1116	16.50	1142	16.93	1166	17.36	1190	17.80

48A4,A5 025-030 (25 THRU 30 TONS) (cont)

Airflow (Cfm)	Available External Static Pressure (in. wg)																			
	2.2		2.4		2.6		2.8		3.0		3.2		3.4		3.6		3.8		4.0	
	Rpm	Bhp	Rpm	Bhp	Rpm	Bhp	Rpm	Bhp	Rpm	Bhp	Rpm	Bhp	Rpm	Bhp	Rpm	Bhp	Rpm	Bhp	Rpm	Bhp
5,000	846	4.31	879	4.65	909	4.99	939	5.34	968	5.68	995	6.03	1022	6.38	1048	6.73	1073	7.08	1097	7.43
6,000	872	5.00	903	5.36	934	5.73	964	6.10	992	6.48	1020	6.85	1047	7.22	1073	7.60	1098	7.98	1123	8.36
7,000	899	5.79	930	6.18	960	6.57	989	6.96	1018	7.36	1045	7.75	1072	8.15	1098	8.55	1123	8.95	1148	9.35
8,000	930	6.72	960	7.12	989	7.53	1017	7.94	1045	8.35	1072	8.76	1098	9.18	1124	9.60	1148	10.02	1173	10.44
9,000	963	7.80	992	8.22	1020	8.63	1048	9.06	1075	9.48	1101	9.91	1126	10.34	1151	10.78	1176	11.21	1200	11.65
10,000	1000	9.06	1028	9.48	1055	9.91	1081	10.34	1107	10.77	1133	11.22	1157	11.66	1182	12.11	—	—	—	—
11,000	1039	10.49	1066	10.92	1092	11.36	1117	11.80	1142	12.24	1167	12.69	1191	13.15	—	—	—	—	—	—
12,000	1080	12.12	1106	12.56	1131	13.00	1156	13.45	1180	13.90	—	—	—	—	—	—	—	—	—	—
13,000	1123	13.95	1148	14.39	1172	14.84	1196	15.30	—	—	—	—	—	—	—	—	—	—	—	—
14,000	1168	15.99	1192	16.44	—	—	—	—	—	—	—	—	—	—	—	—	—	—	—	—
15,000	—	—	—	—	—	—	—	—	—	—	—	—	—	—	—	—	—	—	—	—

LEGEND

Bhp — Brake Horsepower

NOTES:

1. Fan performance is based on wet coils, economizer, roof curb, cabinet losses, and clean 2-in. filters.
2. Conversion — Bhp to watts:

$$\text{Watts} = \frac{\text{Bhp} \times 746}{\text{Motor efficiency}}$$

3. Variable air volume units will operate down to 70 cfm/ton. Performance at 70 cfm/ton is limited to unloaded operation and may be additionally limited by edb and ewb conditions or Humidi-Mizer operation.

Performance data (cont)



FAN PERFORMANCE — HORIZONTAL DISCHARGE UNITS (cont)

50A4,A5 020 (20 TONS)

Airflow (Cfm)	Available External Static Pressure (in. wg)																			
	0.2		0.4		0.6		0.8		1.0		1.2		1.4		1.6		1.8		2.0	
	Rpm	Bhp	Rpm	Bhp	Rpm	Bhp	Rpm	Bhp	Rpm	Bhp	Rpm	Bhp	Rpm	Bhp	Rpm	Bhp	Rpm	Bhp	Rpm	Bhp
4,000	322	0.62	399	0.82	464	1.04	521	1.26	572	1.48	619	1.71	662	1.93	702	2.16	739	2.38	774	2.61
5,000	361	0.95	431	1.17	491	1.41	545	1.65	594	1.89	640	2.14	682	2.39	722	2.64	759	2.89	795	3.14
6,000	405	1.41	467	1.64	524	1.88	574	2.14	621	2.40	664	2.67	705	2.93	744	3.20	780	3.47	816	3.75
7,000	451	2.00	508	2.22	559	2.48	607	2.75	651	3.02	693	3.30	732	3.58	769	3.87	804	4.16	839	4.45
7,500	475	2.34	529	2.57	579	2.82	625	3.10	668	3.38	708	3.66	746	3.96	783	4.25	818	4.55	851	4.84
8,000	500	2.72	551	2.95	598	3.21	643	3.48	685	3.77	724	4.06	762	4.36	797	4.66	832	4.96	864	5.27
9,000	550	3.60	596	3.83	640	4.09	682	4.36	721	4.66	759	4.96	795	5.27	829	5.58	862	5.90	893	6.22
10,000	601	4.63	644	4.86	684	5.12	723	5.40	760	5.70	796	6.01	830	6.33	863	6.65	894	6.98	925	7.31

50A4,A5 020 (20 TONS) (cont)

Airflow (Cfm)	Available External Static Pressure (in. wg)																			
	2.2		2.4		2.6		2.8		3.0		3.2		3.4		3.6		3.8		4.0	
	Rpm	Bhp	Rpm	Bhp	Rpm	Bhp	Rpm	Bhp	Rpm	Bhp	Rpm	Bhp	Rpm	Bhp	Rpm	Bhp	Rpm	Bhp	Rpm	Bhp
4,000	808	2.84	840	3.06	870	3.29	900	3.52	928	3.75	955	3.98	981	4.21	1007	4.44	1031	4.67	1055	4.91
5,000	829	3.39	861	3.64	892	3.89	922	4.14	950	4.40	978	4.65	1005	4.90	1031	5.16	1056	5.41	1080	5.67
6,000	849	4.02	881	4.29	912	4.57	942	4.84	971	5.12	999	5.39	1026	5.67	1052	5.94	1077	6.22	1102	6.49
7,000	871	4.74	903	5.03	933	5.33	963	5.62	991	5.92	1019	6.21	1046	6.51	1072	6.80	1098	7.10	1123	7.40
7,500	883	5.14	915	5.44	945	5.75	974	6.05	1002	6.35	1030	6.66	1057	6.96	1083	7.27	1108	7.58	1133	7.88
8,000	896	5.58	927	5.89	957	6.20	985	6.51	1014	6.82	1041	7.13	1067	7.45	1093	7.76	1118	8.08	1143	8.39
9,000	924	6.54	954	6.86	983	7.19	1011	7.51	1038	7.84	1064	8.17	1090	8.50	1116	8.83	1141	9.16	1165	9.49
10,000	954	7.64	983	7.98	1011	8.31	1038	8.65	1065	8.99	1091	9.34	1116	9.68	1141	10.02	1165	10.37	1189	10.72

50A4,A5 025-030 (25 THRU 30 TONS)

Airflow (Cfm)	Available External Static Pressure (in. wg)																			
	0.2		0.4		0.6		0.8		1.0		1.2		1.4		1.6		1.8		2.0	
	Rpm	Bhp	Rpm	Bhp	Rpm	Bhp	Rpm	Bhp	Rpm	Bhp	Rpm	Bhp	Rpm	Bhp	Rpm	Bhp	Rpm	Bhp	Rpm	Bhp
5,000	366	0.97	435	1.19	495	1.42	548	1.67	597	1.91	642	2.16	685	2.41	724	2.65	762	2.90	797	3.16
6,000	411	1.43	473	1.66	529	1.91	579	2.16	625	2.43	668	2.69	709	2.96	747	3.23	784	3.50	819	3.77
7,000	459	2.02	515	2.25	566	2.51	613	2.78	657	3.06	698	3.34	737	3.62	774	3.91	809	4.20	843	4.49
8,000	508	2.76	559	2.99	606	3.25	650	3.53	691	3.82	731	4.11	768	4.41	803	4.71	837	5.01	870	5.32
9,000	560	3.64	605	3.88	649	4.14	690	4.42	729	4.72	766	5.02	802	5.33	835	5.64	868	5.96	900	6.28
10,000	612	4.68	654	4.92	694	5.19	732	5.47	769	5.77	804	6.09	838	6.40	870	6.73	902	7.06	932	7.39
11,000	665	5.89	703	6.14	740	6.41	776	6.69	811	7.00	844	7.31	876	7.64	907	7.97	937	8.31	967	8.65
12,000	718	7.28	754	7.53	788	7.80	822	8.09	854	8.39	886	8.71	916	9.04	946	9.38	975	9.72	1003	10.07
13,000	772	8.85	806	9.11	838	9.38	869	9.67	899	9.98	929	10.30	958	10.63	987	10.97	1014	11.32	1041	11.68
14,000	826	10.61	858	10.87	888	11.15	917	11.44	946	11.75	974	12.07	1002	12.41	1029	12.75	1055	13.10	1081	13.46
15,000	881	12.57	910	12.84	939	13.12	967	13.41	994	13.72	1021	14.05	1047	14.38	1073	14.73	1098	15.08	1123	15.45

50A4,A5 025-030 (25 THRU 30 TONS) (cont)

Airflow (Cfm)	Available External Static Pressure (in. wg)																			
	2.2		2.4		2.6		2.8		3.0		3.2		3.4		3.6		3.8		4.0	
	Rpm	Bhp	Rpm	Bhp	Rpm	Bhp	Rpm	Bhp	Rpm	Bhp	Rpm	Bhp	Rpm	Bhp	Rpm	Bhp	Rpm	Bhp	Rpm	Bhp
5,000	831	3.41	863	3.66	894	3.91	924	4.16	952	4.41	980	4.67	1007	4.92	1032	5.17	1057	5.43	1082	5.68
6,000	852	4.05	884	4.32	915	4.59	945	4.87	974	5.14	1001	5.42	1028	5.69	1054	5.97	1080	6.24	1105	6.52
7,000	875	4.78	907	5.07	937	5.37	967	5.66	995	5.95	1023	6.25	1049	6.55	1076	6.84	1101	7.14	1126	7.44
8,000	901	5.63	932	5.94	961	6.25	990	6.56	1018	6.87	1045	7.18	1072	7.50	1097	7.81	1123	8.13	1147	8.44
9,000	930	6.60	960	6.93	988	7.25	1016	7.58	1043	7.91	1070	8.23	1096	8.57	1121	8.90	1146	9.23	1170	9.56
10,000	961	7.72	990	8.06	1018	8.40	1045	8.74	1071	9.08	1097	9.42	1122	9.76	1147	10.11	1171	10.46	1194	10.80
11,000	995	8.99	1022	9.34	1049	9.69	1075	10.04	1101	10.39	1126	10.75	1151	11.11	1175	11.47	1198	11.82	—	—
12,000	1030	10.43	1057	10.78	1083	11.14	1108	11.51	1133	11.87	1157	12.24	1181	12.61	—	—	—	—	—	—
13,000	1068	12.04	1093	12.40	1119	12.77	1143	13.14	1167	13.52	1191	13.89	—	—	—	—	—	—	—	—
14,000	1107	13.83	1131	14.20	1156	14.58	1179	14.96	—	—	—	—	—	—	—	—	—	—	—	—
15,000	1147	15.82	1171	16.19	1194	16.58	—	—	—	—	—	—	—	—	—	—	—	—	—	—

LEGEND

Bhp — Brake Horsepower

NOTES:

- Fan performance is based on wet coils, economizer, roof curb, cabinet losses, and clean 2-in. filters.
- Conversion — Bhp to watts:

$$\text{Watts} = \frac{\text{Bhp} \times 746}{\text{Motor efficiency}}$$

- Variable air volume units will operate down to 70 cfm/ton. Performance at 70 cfm/ton is limited to unloaded operation and may be additionally limited by edb and ewb conditions or Humidi-MiZer operation.



FAN PERFORMANCE — STANDARD AND MODULATING POWER EXHAUST

48/50A2,A3,A4,A5020-050 (20 to 50 Tons)						
Airflow (Cfm)	208 V			230, 460, 575 V		
	ESP	Bhp	Watts	ESP	Bhp	Watts
7,700	0.60	3.69	4140	0.73	3.98	4460
7,900	0.56	3.74	4190	0.69	4.02	4510
8,100	0.51	3.78	4240	0.65	4.07	4560
8,500	0.41	3.83	4290	0.56	4.12	4620
8,900	0.31	3.93	4410	0.47	4.23	4740
9,300	0.20	4.07	4560	0.37	4.37	4900
9,700	0.11	4.17	4670	0.30	4.47	5010
10,100	0.04	4.25	4770	0.23	4.56	5110
10,500	—	—	—	0.17	4.66	5220
10,900	—	—	—	0.12	4.75	5330
11,300	—	—	—	0.07	4.80	5380
11,700	—	—	—	0.04	4.83	5420

48/50A2,A3,A4,A5060 (60 Tons)						
Airflow (Cfm)	208 V			230, 460, 575 V		
	ESP	Bhp	Watts	ESP	Bhp	Watts
11,550	0.60	5.54	6210	0.73	5.97	6690
11,850	0.56	5.61	6285	0.69	6.03	6765
12,150	0.51	5.67	6360	0.65	6.10	6840
12,750	0.41	5.74	6435	0.56	6.18	6930
13,350	0.31	5.90	6615	0.47	6.34	7110
13,950	0.20	6.10	6840	0.37	6.56	7350
14,550	0.11	6.25	7005	0.30	6.70	7515
15,150	0.04	6.38	7155	0.23	6.84	7665
15,750	—	—	—	0.17	6.98	7830
16,350	—	—	—	0.12	7.13	7995
16,950	—	—	—	0.07	7.20	8070
17,550	—	—	—	0.04	7.25	8130

LEGEND

Bhp — Brake Horsepower
ESP — External Static Pressure (in. wg)
Watts — Input Watts to Motor

LEGEND

Bhp — Brake Horsepower
ESP — External Static Pressure (in. wg)
Watts — Input Watts to Motor

HIGH CAPACITY POWER EXHAUST ACCESSORY

PART NO.	VOLTAGE	CFM PERFORMANCE VS. STATIC PRESSURE				TOTAL AMPS	NOISE (dB)	
		1/4 in.	3/8 in.	1/2 in.	5/8 in.		at 1 foot	at 10 foot
Single Module								
CRPWREXH071A00	230V/3PH	9,817	9,631	9,591	8,964	12.8	88	77
CRPWREXH072A00	460V/3PH					6.4		
CRPWREXH073A00	575V/3PH					4.8		
Two Module								
CRPWREXH074A00	230V/3PH	19,634	19,262	19,182	17,928	25.6	88	77
CRPWREXH075A00	460V/3PH					12.8		
CRPWREXH076A00	575V/3PH					9.6		
Three Module								
CRPWREXH077A00	230V/3PH	29,451	28,893	28,773	26,892	38.4	88	77
CRPWREXH078A00	460V/3PH					19.2		
CRPWREXH079A00	575V/3PH					14.4		

HUMIDI-MIZER® SYSTEM COMPONENT PRESSURE DROPS (in. wg) SIZE 020-035 UNITS

COMPONENT	AIRFLOW (cfm)					
	4,000	6,000	8,000	10,000	12,000	14,000
HUMIDI-MIZER	0.012	0.022	0.035	0.050	0.068	0.089

HUMIDI-MIZER SYSTEM COMPONENT PRESSURE DROPS (in. wg) SIZE 040,050 UNITS

COMPONENT	AIRFLOW (cfm)						
	8,000	10,000	12,000	14,000	16,000	18,000	20,000
HUMIDI-MIZER	0.035	0.050	0.068	0.089	0.112	0.137	0.165

HUMIDI-MIZER SYSTEM COMPONENT PRESSURE DROPS (in. wg) SIZE 060 UNITS

COMPONENT	AIRFLOW (cfm)						
	12,000	14,000	16,000	18,000	20,000	22,000	24,000
HUMIDI-MIZER	0.002	0.004	0.010	0.023	0.044	0.077	0.125

Performance data (cont)



SUPPLY MOTOR LIMITATIONS

PREMIUM-EFFICIENCY MOTORS						
Nominal		Maximum		Maximum Amps		Maximum Efficiency
Bhp	BkW	Bhp	BkW	230 v	460 v	
5	3.73	5.9	4.40	15.8	7.9	89.5
10	7.46	10.2	7.61	30.0	—	91.7
		11.8	8.80	—	15.0	91.7
15	11.19	15.3	11.41	46.0	—	93.0
		18.0	13.43	—	22.0	93.0
20	14.92	22.4	16.71	59.0	—	93.6
		23.4	17.46	—	28.7	93.6
25	18.65	28.9	21.56	73.0	—	93.6
		29.4	21.93	—	36.3	93.6
30	22.38	35.6	26.56	82.6	—	93.6
		34.7	25.89	—	41.7	93.6
40	29.84	42.0	31.33	110.0	55.0	94.5

LEGEND

Bhp — Brake Horsepower
BkW — Brake Kilowatts

shown in the Motor Limitations table will not result in nuisance tripping or premature motor failures. Unit warranty will not be affected.
 2. All motors comply with Energy Policy Act (EPACT) Standards effective October 24, 1997.

NOTES:

1. Extensive motor and electrical testing on the Carrier units has ensured that the full horsepower range of the motor can be utilized with confidence. Using the fan motors up to the horsepower ratings

AIR QUANTITY LIMITS (48A2,A3,A4,A5)

UNIT 48A2,A3,A4,A5	MINIMUM HEATING AIRFLOW CFM (Low Heat)	MINIMUM HEATING AIRFLOW CFM (High Heat)	MINIMUM COOLING AIRFLOW (VAV) CFM AT FULL LOAD	MINIMUM COOLING AIRFLOW CFM (CV)	MAXIMUM AIRFLOW CFM
020	5,900	6,100	4,000	6,000	10,000
025	5,900	6,100	5,000	7,500	12,500
027	5,900	6,100	5,400	8,100	13,500
030	5,900	6,100	6,000	9,000	15,000
035	5,900	10,100	7,000	10,500	17,500
040	7,600	10,100	8,000	12,000	20,000
050	7,600	10,100	10,000	13,500	20,000
060	11,000	14,700	12,000	18,000	27,000

LEGEND

CV — Constant Volume
VAV — Variable Air Volume

NOTE: Variable air volume units will operate down to 70 cfm/ton in Cooling mode. Performance at 70 cfm/ton is limited to unloaded operation and may be also limited by edb (entering dry bulb) and ewb (entering wet bulb) conditions.

AIR QUANTITY LIMITS (50A2,A3,A4,A5)

UNIT	COOLING		ELECTRIC HEAT	
	Min CFM	Max CFM*	Min CFM	Max CFM
50A2,A4020	6,000	10,000	6,000	15,000
50A3,A5020	4,000	10,000		
50A2,A4025	7,500	12,500		
50A3,A5025	5,000	12,500		
50A2,A4027	8,100	13,500		
50A3,A5027	5,400	13,500		
50A2,A4030	9,000	15,000		
50A3,A5030	6,000	15,000		
50A2,A4035	10,500	17,500		
50A3,A5035	7,000	17,500		
50A2,A4040	12,000	20,000	10,500	20,000
50A3,A5040	8,000	20,000		
50A2,A4050	13,500	20,000		
50A3,A5050	10,000	20,000		
50A2,A4060	18,000	27,000		
50A3,A5060	12,000	27,000		

*Operation at these levels may be limited by entering evaporator air wet bulb temperatures.

NOTES:

1. Extensive motor and electrical testing on the Carrier units has ensured that the full horsepower range of the motor can be utilized with confidence. Using the fan motors up to the horsepower ratings

shown in the Motor Limitations table will not result in nuisance tripping or premature motor failure. Unit warranty will not be affected.
 2. All motors comply with Energy Policy Act (EPACT) Standards effective October 24, 1997.

LEGEND AND NOTES FOR ELECTRICAL DATA TABLES

LEGEND

FLA	— Full Load Amps
HACR	— Heating, Air Conditioning and Refrigeration
LRA	— Locked Rotor Amps
MCA	— Minimum Circuit Amps
MCHX	— Microchannel
MOCP	— Maximum Overcurrent Protection
NEC	— National Electrical Code
RLA	— Rated Load Amps
RTPF	— Round Tube Plate Fin

*Fuse or HACR circuit breaker.



NOTES:

- In compliance with NEC requirements for multimotor and combination load equipment (refer to NEC Articles 430 and 440), the overcurrent protective device for the unit shall be fuse or HACR breaker.
- Unbalanced 3-Phase Supply Voltage**
Never operate a motor where a phase imbalance in supply voltage is greater than 2%. Use the following formula to determine the percent voltage imbalance.

% Voltage Imbalance

$$= 100 \times \frac{\text{max voltage deviation from average voltage}}{\text{average voltage}}$$

EXAMPLE: Supply voltage is 460-3-60.

AB = 452 v
 BC = 464 v
 AC = 455 v



$$\text{Average Voltage} = \frac{452 + 464 + 455}{3}$$

$$= \frac{1371}{3}$$

$$= 457$$

Determine maximum deviation from average voltage.

(AB) 457 - 452 = 5 v
 (BC) 464 - 457 = 7 v
 (AC) 457 - 455 = 2 v

Maximum deviation is 7 v.

Determine percent voltage imbalance.

$$\% \text{ Voltage Imbalance} = 100 \times \frac{7}{457}$$

Electrical data (cont)



48A2,A3,A4,A5 UNITS WITHOUT CONVENIENCE OUTLET

UNIT SIZE 48A	VOLTAGE 3 PH, 60 Hz	VOLTAGE RANGE		COMPRESSOR								CONDENSER FAN MOTOR		EVAPORATOR FAN MOTOR		POWER EXHAUST	POWER SUPPLY	
		Min	Max	Cir A, No. 1		Cir A, No. 2		Cir B, No. 1		Cir B, No. 2		Qty	FLA	Hp	FLA	FLA (total)	MCA	MOCP*
				RLA	LRA	RLA	LRA	RLA	LRA	RLA	LRA							
020	208	187	229	22.4	149	22.4	149	27.6	191	—	—	2	6.5 (ea)	5	16.7	—	109.0	125
														10	30.8	23.6	132.6	150
														15	46.2	23.6	123.9	150
	230	207	253	22.4	149	22.4	149	27.6	191	—	—	2	6.6 (ea)	5	15.2	—	143.2	175
														10	28.0	23.6	147.5	175
														15	42.0	23.6	143.2	200
	460	414	508	10.6	75	10.6	75	12.8	100	—	—	2	3.3 (ea)	5	7.6	—	51.4	60
														10	14.0	12.6	64.0	70
														15	21.0	12.6	58.1	80
	575	518	632	7.7	54	7.7	54	12.2	80	—	—	2	2.6 (ea)	5	6.1	—	66.9	80
														10	11.0	9.6	79.5	100
														15	17.0	9.6	42.0	50
025	208	187	229	27.6	191	27.6	191	27.6	191	—	—	2	6.5 (ea)	5	16.7	—	119.4	125
														10	30.8	23.6	143.0	150
														15	46.2	23.6	134.3	175
	230	207	253	27.6	191	27.6	191	27.6	191	—	—	2	6.6 (ea)	5	15.2	—	153.6	175
														10	28.0	23.6	177.2	200
														15	42.0	23.6	118.1	125
	460	414	508	12.8	100	12.8	100	12.8	100	—	—	2	3.3 (ea)	5	7.6	—	55.8	60
														10	14.0	12.6	68.4	80
														15	21.0	12.6	62.5	70
	575	518	632	12.2	80	12.2	80	12.2	80	—	—	2	2.6 (ea)	5	6.1	—	71.3	90
														10	11.0	9.6	83.9	100
														15	17.0	9.6	51.0	60
027	208	187	229	27.6	191	27.6	191	27.6	191	—	—	2	6.5 (ea)	10	30.8	—	134.3	150
														15	46.2	23.6	157.9	175
														20	59.4	23.6	153.6	200
	230	207	253	27.6	191	27.6	191	27.6	191	—	—	2	6.6 (ea)	10	28.0	—	170.1	225
														15	42.0	23.6	193.7	250
														20	54.0	23.6	131.0	150
	460	414	508	12.8	100	12.8	100	12.8	100	—	—	2	3.3 (ea)	10	14.0	—	154.6	175
														15	21.0	12.6	148.5	200
														20	27.0	12.6	172.1	200
	575	518	632	12.2	80	12.2	80	12.2	80	—	—	2	2.6 (ea)	10	11.0	—	163.5	200
														15	17.0	9.6	187.1	225
														20	22.0	9.6	62.5	70

See Legend and Notes on page 83.

48A2,A3,A4,A5 UNITS WITHOUT CONVENIENCE OUTLET (cont)

UNIT SIZE 48A	VOLTAGE 3 PH, 60 Hz	VOLTAGE RANGE		COMPRESSOR								CONDENSER FAN MOTOR		EVAPORATOR FAN MOTOR		POWER EXHAUST	POWER SUPPLY	
				Cir A, No. 1		Cir A, No. 2		Cir B, No. 1		Cir B, No. 2								
		Min	Max	RLA	LRA	RLA	LRA	RLA	LRA	RLA	LRA	Qty	FLA	Hp	FLA	FLA (total)	MCA	MOCPS*
030	208	187	229	23.2	184	23.2	164	23.2	164	23.2	164	2	6.5 (ea)	10	30.8	—	144.3	175
														15	46.2	23.6	163.6	200
														20	59.4	23.6	180.1	225
	230	207	253	23.2	164	23.2	164	23.2	164	23.2	164	2	6.6 (ea)	10	28.0	23.6	141.0	150
														15	42.0	23.6	158.5	200
														20	54.0	23.6	173.5	225
	460	414	508	11.2	75	11.2	75	11.2	75	11.2	75	2	3.3 (ea)	10	14.0	12.6	68.9	80
														15	21.0	12.6	77.7	90
														20	27.0	12.6	85.2	110
	575	518	632	7.9	54	7.9	54	7.9	54	7.9	54	2	2.6 (ea)	10	11.0	9.6	50.6	60
														15	17.0	9.6	58.1	70
														20	22.0	9.6	64.3	80
035	208	187	229	22.4	149	22.4	149	28.2	239	28.2	239	2	6.5 (ea)	15	46.2	23.6	172.0	200
														20	59.4	23.6	188.5	225
														25	74.8	23.6	207.7	250
	230	207	253	22.4	149	22.4	149	28.2	239	28.2	239	2	6.6 (ea)	15	42.0	23.6	166.9	200
														20	54.0	23.6	181.9	225
														25	68.0	23.6	199.4	250
	460	414	508	10.6	75	10.6	75	14.7	130	14.7	130	2	3.3 (ea)	15	21.0	12.6	83.5	100
														20	27.0	12.6	91.0	110
														25	27.0	12.6	99.7	125
	575	518	632	7.7	54	7.7	54	11.3	93.7	11.3	93.7	2	2.6 (ea)	15	17.0	9.6	64.5	80
														20	22.0	9.6	70.7	90
														25	27.0	9.6	77.0	100
040	208	187	229	28.2	239	28.2	239	28.2	239	28.2	239	4	6.5 (ea)	15	46.2	23.6	196.6	225
														20	59.4	23.6	213.1	250
														25	74.8	23.6	232.3	300
	230	207	253	28.2	239	28.2	239	28.2	239	28.2	239	4	6.6 (ea)	15	42.0	23.6	191.7	225
														20	54.0	23.6	206.7	250
														25	68.0	23.6	224.2	250
	460	414	508	14.7	130	14.7	130	14.7	130	14.7	130	4	3.3 (ea)	15	21.0	12.6	98.3	110
														20	21.0	12.6	105.8	125
														25	34.0	12.6	114.5	125
	575	518	632	11.3	93.7	11.3	93.7	11.3	93.7	11.3	93.7	4	2.6 (ea)	15	17.0	9.6	76.9	90
														20	17.0	9.6	83.1	100
														25	17.0	9.6	89.4	110

See Legend and Notes on page 83.

Electrical data (cont)



48A2,A3,A4,A5 UNITS WITHOUT CONVENIENCE OUTLET (cont)

UNIT SIZE 48A	VOLTAGE 3 PH, 60 Hz	VOLTAGE RANGE		COMPRESSOR								CONDENSER FAN MOTOR		EVAPORATOR FAN MOTOR		POWER EXHAUST	POWER SUPPLY			
		Min	Max	Cir A, No. 1		Cir A, No. 2		Cir B, No. 1		Cir B, No. 2		Qty	FLA	Hp	FLA	FLA (total)	MCA	MOCP*		
				RLA	LRA	RLA	LRA	RLA	LRA	RLA	LRA									
050	208	187	229	34	240	34	240	34	240	34	240	4	6.5 (ea)	20	59.4	— 23.6	236.3 259.9	250 300		
														25	74.8	— 23.6	255.5 279.1	300 350		
														30	88.0	— 23.6	272.0 295.6	350 350		
	230	207	253	34	240	34	240	34	240	34	240	34	240	4	6.6 (ea)	20	54.0	— 23.6	229.9 253.5	250 300
																25	68.0	— 23.6	247.4 271.0	300 300
																30	80.0	— 23.6	262.4 286.0	300 350
	460	414	508	16	140	16	140	16	140	16	140	16	140	4	3.3 (ea)	20	27.0	— 12.6	111.0 123.6	125 150
																25	34.0	— 12.6	119.7 132.3	150 150
																30	40.0	— 12.6	127.2 139.8	150 175
	575	518	632	12.9	108	12.9	108	12.9	108	12.9	108	12.9	108	4	2.6 (ea)	20	22.0	— 9.6	89.5 99.1	110 110
																25	27.0	— 9.6	95.8 105.4	110 125
																30	32.0	— 9.6	102.0 111.6	125 125
060 (MCHX)	208	187	229	51.3	300	51.3	300	51.3	300	51.3	300	51.3	300	4	5.5 (ea)	25	74.8	— 35.4	320.7 356.1	350 400
																30	88.0	— 35.4	337.2 372.6	400 450
																40	114.0	— 35.4	369.7 405.1	450 500
	230	207	253	51.3	300	51.3	300	51.3	300	51.3	300	51.3	300	4	5.8 (ea)	25	68.0	— 35.4	313.4 348.8	350 400
																30	80.0	— 35.4	328.4 363.8	400 400
																40	104.0	— 35.4	358.4 393.8	450 450
	460	414	508	22.4	150	22.4	150	22.4	150	22.4	150	22.4	150	4	2.9 (ea)	25	34.0	— 18.9	143.7 162.6	175 175
																30	40.0	— 18.9	151.2 170.1	175 200
																40	52.0	— 18.9	166.2 185.1	200 225
	575	518	632	19.9	109	19.9	109	19.9	109	19.9	109	19.9	109	4	2.3 (ea)	25	27.0	— 14.4	122.6 137.0	125 150
																30	32.0	— 14.4	128.8 143.2	150 175
																40	41.0	— 14.4	140.1 154.5	175 175
060 (RTPF)	208	187	229	51.3	300	51.3	300	51.3	300	51.3	300	51.3	300	6	6.5 (ea)	25	74.8	— 35.4	337.7 373.1	400 400
																30	88.0	— 35.4	354.2 389.6	400 450
																40	114.0	— 35.4	386.7 422.1	500 500
	230	207	253	51.3	300	51.3	300	51.3	300	51.3	300	51.3	300	6	6.6 (ea)	25	68.0	— 35.4	329.8 365.2	350 400
																30	80.0	— 35.4	344.8 380.2	400 450
																40	104.0	— 35.4	374.8 410.2	450 500
	460	414	508	22.4	150	22.4	150	22.4	150	22.4	150	22.4	150	6	3.3 (ea)	25	34.0	— 18.9	151.9 170.8	175 200
																30	40.0	— 18.9	159.4 178.3	175 200
																40	52.0	— 18.9	174.4 193.3	225 225
	575	518	632	19.9	109	19.9	109	19.9	109	19.9	109	19.9	109	6	2.6 (ea)	25	27.0	— 14.4	129.0 143.4	150 150
																30	32.0	— 14.4	135.2 149.6	150 175
																40	41.0	— 14.4	146.5 160.9	175 200

See Legend and Notes on page 83.

48A2,A3,A4,A5 UNITS WITH CONVENIENCE OUTLET

UNIT SIZE 48A	VOLTAGE 3 PH, 60 Hz	VOLTAGE RANGE		COMPRESSOR								CONDENSER FAN MOTOR		EVAPORATOR FAN MOTOR		POWER EXHAUST	CONVENIENCE OUTLET		POWER SUPPLY		
		Min	Max	Cir A, No. 1		Cir A, No. 2		Cir B, No. 1		Cir B, No. 2		Qty	FLA	Hp	FLA	FLA (total)	FLA	MCA	MOCP*		
				RLA	LRA	RLA	LRA	RLA	LRA	RLA	LRA										
020	208	187	229	22.4	149	22.4	149	27.6	191	—	—	2	6.5 (ea)	5	16.7	—	23.6	7.0	7.0	116.0	125
														10	30.8	—	23.6	7.0	7.0	130.9	150
														15	46.2	—	23.6	7.0	7.0	150.2	175
	230	207	253	22.4	149	22.4	149	27.6	191	—	—	2	6.6 (ea)	5	15.2	—	23.6	7.0	7.0	114.7	125
														10	28.0	—	23.6	7.0	7.0	127.6	150
														15	42.0	—	23.6	7.0	7.0	145.1	175
	460	414	508	10.6	75	10.6	75	12.8	100	—	—	2	3.3 (ea)	5	7.6	—	12.6	3.5	3.5	54.9	60
														10	14.0	—	12.6	3.5	3.5	61.6	70
														15	21.0	—	12.6	3.5	3.5	70.4	80
	575	518	632	7.7	54	7.7	54	12.2	80	—	—	2	2.6 (ea)	5	6.1	—	9.6	2.5	2.5	44.5	50
														10	11.0	—	9.6	2.5	2.5	49.4	60
														15	17.0	—	9.6	2.5	2.5	56.6	70
025	208	187	229	27.6	191	27.6	191	27.6	191	—	—	2	6.5 (ea)	5	16.7	—	23.6	7.0	7.0	126.4	150
														10	30.8	—	23.6	7.0	7.0	141.3	175
														15	46.2	—	23.6	7.0	7.0	160.6	200
	230	207	253	27.6	191	27.6	191	27.6	191	—	—	2	6.6 (ea)	5	15.2	—	23.6	7.0	7.0	125.1	150
														10	28.0	—	23.6	7.0	7.0	138.0	175
														15	42.0	—	23.6	7.0	7.0	155.5	200
	460	414	508	12.8	100	12.8	100	12.8	100	—	—	2	3.3 (ea)	5	7.6	—	12.6	3.5	3.5	59.3	70
														10	14.0	—	12.6	3.5	3.5	66.0	80
														15	21.0	—	12.6	3.5	3.5	74.8	90
	575	518	632	12.2	80	12.2	80	12.2	80	—	—	2	2.6 (ea)	5	6.1	—	9.6	2.5	2.5	53.5	60
														10	11.0	—	9.6	2.5	2.5	58.4	70
														15	17.0	—	9.6	2.5	2.5	65.6	80
027	208	187	229	27.6	191	27.6	191	27.6	191	—	—	2	6.5 (ea)	10	30.8	—	23.6	7.0	7.0	141.3	150
														15	46.2	—	23.6	7.0	7.0	160.6	200
														20	59.4	—	23.6	7.0	7.0	177.1	225
	230	207	253	27.6	191	27.6	191	27.6	191	—	—	2	6.6 (ea)	10	28.0	—	23.6	7.0	7.0	138.0	150
														15	42.0	—	23.6	7.0	7.0	155.5	175
														20	54.0	—	23.6	7.0	7.0	170.5	200
	460	414	508	12.8	100	12.8	100	12.8	100	—	—	2	3.3 (ea)	10	14.0	—	12.6	3.5	3.5	66.0	80
														15	21.0	—	12.6	3.5	3.5	74.8	90
														20	27.0	—	12.6	3.5	3.5	82.3	100
	575	518	632	12.2	80	12.2	80	12.2	80	—	—	2	2.6 (ea)	10	11.0	—	9.6	2.5	2.5	58.4	70
														15	17.0	—	9.6	2.5	2.5	65.6	80
														20	22.0	—	9.6	2.5	2.5	71.8	90

See Legend and Notes on page 83.

Electrical data (cont)



48A2,A3,A4,A5 UNITS WITH CONVENIENCE OUTLET (cont)

UNIT SIZE 48A	VOLTAGE 3 PH, 60 Hz	VOLTAGE RANGE		COMPRESSOR								CONDENSER FAN MOTOR		EVAPORATOR FAN MOTOR		POWER EXHAUST	CONVENIENCE OUTLET		POWER SUPPLY	
		Min	Max	Cir A, No. 1		Cir A, No. 2		Cir B, No. 1		Cir B, No. 2		Qty	FLA	Hp	FLA	FLA (total)	FLA	MCA	MOCP*	
				RLA	LRA	RLA	LRA	RLA	LRA	RLA	LRA									
030	208	187	229	23.2	184	23.2	164	23.2	164	23.2	164	2	6.5 (ea)	10	30.8	— 23.6	7.0 7.0	151.3 174.9	175 200	
														15	46.2	— 23.6	7.0 7.0	170.6 194.2	200 225	
														20	59.4	— 23.6	7.0 7.0	187.1 210.7	225 250	
	230	207	253	23.2	164	23.2	164	23.2	164	23.2	164	2	6.6 (ea)	10	28.0	— 23.6	7.0 7.0	148.0 171.6	175 175	
														15	42.0	— 23.6	7.0 7.0	165.5 189.1	200 225	
														20	54.0	— 23.6	7.0 7.0	180.5 204.1	225 250	
	460	414	508	11.2	75	11.2	75	11.2	75	11.2	75	2	3.3 (ea)	10	14.0	— 12.6	3.5 3.5	72.4 85.0	80 90	
														15	21.0	— 12.6	3.5 3.5	81.2 93.8	100 110	
														20	27.0	— 12.6	3.5 3.5	88.7 101.3	110 125	
	575	518	632	7.9	54	7.9	54	7.9	54	7.9	54	2	2.6 (ea)	10	11.0	— 9.6	2.5 2.5	53.1 62.7	60 70	
														15	17.0	— 9.6	2.5 2.5	60.6 70.2	70 80	
														20	22.0	— 9.6	2.5 2.5	66.8 76.4	80 90	
035	208	187	229	22.4	149	22.4	149	28.2	239	28.2	239	2	6.5 (ea)	15	46.2	— 23.6	7.0 7.0	179.0 202.6	225 225	
														20	59.4	— 23.6	7.0 7.0	195.5 219.1	250 250	
														25	74.8	— 23.6	7.0 7.0	214.7 238.3	250 300	
	230	207	253	22.4	149	22.4	149	28.2	239	28.2	239	2	6.6 (ea)	15	42.0	— 23.6	7.0 7.0	173.9 197.5	200 225	
														20	54.0	— 23.6	7.0 7.0	188.9 212.5	225 250	
														25	68.0	— 23.6	7.0 7.0	206.4 230.0	250 250	
	460	414	508	10.6	75	10.6	75	14.7	130	14.7	130	2	3.3 (ea)	15	21.0	— 12.6	3.5 3.5	87.0 99.6	100 110	
														20	27.0	— 12.6	3.5 3.5	94.5 107.1	110 125	
														25	34.0	— 12.6	3.5 3.5	103.2 115.8	125 125	
	575	518	632	7.7	54	7.7	54	11.3	93.7	11.3	93.7	2	2.6 (ea)	15	17.0	— 9.6	2.5 2.5	67.0 76.6	80 90	
														20	22.0	— 9.6	2.5 2.5	73.2 82.8	90 100	
														25	27.0	— 9.6	2.5 2.5	79.5 89.1	100 110	
040	208	187	229	28.2	239	28.2	239	28.2	239	28.2	239	4	6.5 (ea)	15	46.2	— 23.6	7.0 7.0	203.6 227.2	225 250	
														20	59.4	— 23.6	7.0 7.0	220.1 243.7	250 300	
														25	74.8	— 23.6	7.0 7.0	239.3 262.9	300 300	
	230	207	253	28.2	239	28.2	239	28.2	239	28.2	239	4	6.6 (ea)	15	42.0	— 23.6	7.0 7.0	198.7 222.3	225 250	
														20	54.0	— 23.6	7.0 7.0	213.7 237.3	250 250	
														25	68.0	— 23.6	7.0 7.0	231.2 254.8	250 300	
	460	414	508	14.7	130	14.7	130	14.7	130	14.7	130	4	3.3 (ea)	15	21.0	— 12.6	3.5 3.5	101.8 114.4	110 125	
														20	27.0	— 12.6	3.5 3.5	109.3 121.9	125 125	
														25	34.0	— 12.6	3.5 3.5	118.0 130.6	150 150	
	575	518	632	11.3	93.7	11.3	93.7	11.3	93.7	11.3	93.7	4	2.6 (ea)	15	17.0	— 9.6	2.5 2.5	79.4 89.0	90 100	
														20	22.0	— 9.6	2.5 2.5	85.6 95.2	100 110	
														25	27.0	— 9.6	2.5 2.5	91.9 101.5	110 125	

See Legend and Notes on page 83.

48A2,A3,A4,A5 UNITS WITH CONVENIENCE OUTLET (cont)

UNIT SIZE 48A	VOLTAGE 3 PH, 60 Hz	VOLTAGE RANGE		COMPRESSOR								CONDENSER FAN MOTOR		EVAPORATOR FAN MOTOR			POWER EXHAUST	CONVENIENCE OUTLET	POWER SUPPLY	
		Min	Max	Cir A, No. 1		Cir A, No. 2		Cir B, No. 1		Cir B, No. 2		Qty	FLA	Hp	FLA	FLA (total)	FLA	MCA	MOCP*	
				RLA	LRA	RLA	LRA	RLA	LRA	RLA	LRA									
050	208	187	229	34	240	34	240	34	240	34	240	4	6.5 (ea)	20	59.4	—	23.6	7.0	243.3	300
														25	77.8	—	23.6	7.0	262.5	300
														30	88.0	—	23.6	7.0	279.0	350
	230	207	253	34	240	34	240	34	240	34	240	4	6.6 (ea)	20	54.0	—	23.6	7.0	236.9	250
														25	68.0	—	23.6	7.0	254.4	300
														30	80.0	—	23.6	7.0	269.4	300
	460	414	508	16	140	16	140	16	140	16	140	4	3.3 (ea)	20	27.0	—	12.6	3.5	114.5	125
														25	34.0	—	12.6	3.5	123.2	150
														30	40.0	—	12.6	3.5	130.7	150
	575	518	632	12.9	108	12.9	108	12.9	108	12.9	108	4	2.6 (ea)	20	22.0	—	9.6	2.5	92.0	110
														25	27.0	—	9.6	2.5	98.3	125
														30	32.0	—	9.6	2.5	104.5	125
060 (MCHX)	208	187	229	51.3	300	51.3	300	51.3	300	51.3	300	4	5.5 (ea)	25	75.0	—	35.4	7.0	327.7	400
														30	88.0	—	35.4	7.0	344.2	400
														40	114.0	—	35.4	7.0	376.7	450
	230	207	253	51.3	300	51.3	300	51.3	300	51.3	300	4	5.8 (ea)	25	68.0	—	35.4	7.0	320.4	350
														30	80.0	—	35.4	7.0	335.4	400
														40	104.0	—	35.4	7.0	365.4	450
	460	414	508	22.4	150	22.4	150	22.4	150	22.4	150	4	2.9 (ea)	25	34.0	—	18.9	3.5	147.2	175
														30	40.0	—	18.9	3.5	154.7	200
														40	52.0	—	18.9	3.5	169.7	200
	575	518	632	19.9	109	19.9	109	19.9	109	19.9	109	4	2.3 (ea)	25	27.0	—	14.4	2.5	125.1	150
														30	32.0	—	14.4	2.5	131.3	150
														40	41.0	—	14.4	2.5	142.6	175
060 (RTPF)	208	187	229	51.3	300	51.3	300	51.3	300	51.3	300	6	6.5 (ea)	25	74.8	—	35.4	7.0	344.7	400
														30	88.0	—	35.4	7.0	361.2	400
														40	114.0	—	35.4	7.0	393.7	500
	230	207	253	51.3	300	51.3	300	51.3	300	51.3	300	6	6.6 (ea)	25	68.0	—	35.4	7.0	336.8	400
														30	80.0	—	35.4	7.0	351.8	400
														40	104.0	—	35.4	7.0	381.8	450
	460	414	508	22.4	150	22.4	150	22.4	150	22.4	150	6	3.3 (ea)	25	34.0	—	18.9	3.5	155.4	175
														30	40.0	—	18.9	3.5	162.9	200
														40	52.0	—	18.9	3.5	177.9	225
	575	518	632	19.9	109	19.9	109	19.9	109	19.9	109	6	2.6 (ea)	25	27.0	—	14.4	2.5	131.5	150
														30	32.0	—	14.4	2.5	137.7	150
														40	41.0	—	14.4	2.5	149.0	175

See Legend and Notes on page 83.

Electrical data (cont)



50A2,A3,A4,A5 UNITS WITHOUT CONVENIENCE OUTLET

UNIT SIZE 50A	VOLTAGE 3 PH, 60 Hz	VOLTAGE RANGE		COMPRESSOR								CONDENSER FAN MOTOR		EVAPORATOR FAN MOTOR		POWER EXHAUST	OPTIONAL ELECTRIC HEAT		POWER SUPPLY	
				Cir A, No. 1		Cir A, No. 2		Cir B, No. 1		Cir B, No. 2		Qty	FLA	Hp	FLA	FLA (total)	FLA	kW	MCA	MOCP*
		Min	Max	RLA	LRA	RLA	LRA	RLA	LRA	RLA	LRA	RLA	LRA							
020	208	187	229	22.4	149	22.4	149	27.6	191	—	—	2	6.5 (ea)	5	16.7	—	—	—	109.0	125
																75.1	150.1	27	114.8	125
																54	54	54	171.0	200
																23.6	75.1	27	132.6	150
																150.1	54	54	144.3	150
																200.5	200.5	225	200.5	225
	230	207	253	22.4	149	22.4	149	27.6	191	—	—	2	6.6 (ea)	5	15.2	—	—	—	107.7	125
																86.6	173.2	36	127.3	150
																72	72	72	192.2	225
																23.6	86.6	36	131.3	150
																173.2	72	72	156.8	175
																221.7	221.7	225	221.7	225
380	342	418	11	75.3	11	75.3	16.7	123	—	—	2	3.6 (ea)	5	9.1	—	—	—	59.2	70	
															34.2	68.4	23	59.2	70	
															45	45	45	96.9	100	
															14.8	34.2	23	74.0	90	
															68.4	45	45	74.0	90	
															115.4	115.4	125	115.4	125	
460	414	508	10.6	75	10.6	75	12.8	100	—	—	2	3.3 (ea)	5	7.6	—	—	—	51.4	60	
															43.3	86.6	36	63.6	70	
															72	72	72	96.1	110	
															12.6	43.3	36	64.0	70	
															86.6	72	72	79.4	80	
															111.9	111.9	125	111.9	125	
575	518	632	7.7	54	7.7	54	12.2	80	—	—	2	2.6 (ea)	5	6.1	—	—	—	42.0	50	
															34.6	69.3	36	50.9	60	
															72	72	72	76.9	90	
															9.6	34.6	36	51.6	60	
															69.3	72	72	62.9	70	
															88.9	88.9	100	88.9	100	
575	518	632	7.7	54	7.7	54	12.2	80	—	—	2	2.6 (ea)	10	11.0	—	—	—	46.9	50	
															34.6	69.3	36	57.0	60	
															72	72	72	83.1	90	
															9.6	34.6	36	56.5	60	
															69.3	72	72	69.0	70	
															95.1	95.1	100	95.1	100	
575	518	632	7.7	54	7.7	54	12.2	80	—	—	2	2.6 (ea)	15	17.0	—	—	—	54.1	70	
															34.6	69.3	36	64.5	70	
															72	72	72	90.6	100	
															9.6	34.6	36	63.7	80	
															69.3	72	72	76.5	80	
															102.6	102.6	110	102.6	110	

See Legend and Notes on page 83.

50A2,A3,A4,A5 UNITS WITHOUT CONVENIENCE OUTLET (cont)

UNIT SIZE 50A	VOLTAGE 3 PH, 60 Hz	VOLTAGE RANGE		COMPRESSOR								CONDENSER FAN MOTOR		EVAPORATOR FAN MOTOR		POWER EXHAUST FLA (total)	OPTIONAL ELECTRIC HEAT		POWER SUPPLY	
				Cir A, No. 1		Cir A, No. 2		Cir B, No. 1		Cir B, No. 2							FLA	kW	MCA	MOCP*
		Min	Max	RLA	LRA	RLA	LRA	RLA	LRA	RLA	LRA	RLA	LRA	Qty	FLA	Hp	FLA	FLA	FLA	kW
025	208	187	229	27.6	191	27.6	191	27.6	191	—	—	2	6.5 (ea)	5	16.7	—	75.1 150.1	27 54	119.4 119.4 171.0	125 125 200
																23.6	75.1 150.1	27 54	143.0 144.3 200.5	150 150 225
																—	75.1 150.1	27 54	134.3 134.3 188.6	150 150 200
																23.6	75.1 150.1	27 54	157.9 161.9 218.1	175 175 225
																—	75.1 150.1	27 54	153.6 153.6 207.9	175 175 250
																23.6	75.1 150.1	27 54	177.2 181.1 237.4	200 200 250
	230	207	253	27.6	191	27.6	191	27.6	191	—	—	2	6.6 (ea)	5	15.2	—	86.6 173.2	36 72	118.1 118.1 192.2	125 150 225
																23.6	86.6 173.2	36 72	141.7 156.8 221.7	150 175 225
																—	86.6 173.2	36 72	131.0 143.3 208.2	150 150 225
																23.6	86.6 173.2	36 72	154.6 172.8 237.7	175 175 250
																—	86.6 173.2	36 72	148.5 160.8 225.7	175 175 250
																23.6	86.6 173.2	36 72	172.1 190.3 255.2	200 200 300
380	342	418	16.7	123	16.7	123	16.7	123	—	—	2	3.6 (ea)	5	9.1	—	34.2 68.4	23 45	70.6 70.6 96.9	80 80 100	
															14.8	34.2 68.4	23 45	85.4 85.4 115.4	100 100 125	
															—	34.2 68.4	23 45	78.2 78.2 106.4	90 90 110	
															14.8	34.2 68.4	23 45	93.0 93.0 124.9	100 100 125	
															—	34.2 68.4	23 45	87.9 87.9 116.1	110 110 125	
															14.8	34.2 68.4	23 45	102.7 102.7 134.6	125 125 150	
460	414	508	12.8	100	12.8	100	12.8	100	—	—	2	3.3 (ea)	5	7.6	—	43.3 86.6	36 72	55.8 63.6 96.1	60 70 110	
															12.6	43.3 86.6	36 72	68.4 79.4 111.9	80 80 125	
															—	43.3 86.6	36 72	62.5 71.6 104.1	70 80 110	
															12.6	43.3 86.6	36 72	75.1 87.4 119.9	80 90 125	
															—	43.3 86.6	36 72	71.3 80.4 112.9	90 90 125	
															12.6	43.3 86.6	36 72	83.9 96.1 128.6	100 100 150	
575	518	632	12.2	80	12.2	80	12.2	80	—	—	2	2.6 (ea)	5	6.1	—	34.6 69.3	36 72	51.0 51.0 76.9	60 60 90	
															9.6	34.6 69.3	36 72	60.6 62.9 88.9	70 70 100	
															—	34.6 69.3	36 72	55.9 57.0 83.1	60 60 90	
															9.6	34.6 69.3	36 72	65.5 69.0 95.1	70 70 100	
															—	34.6 69.3	36 72	63.1 64.5 90.6	80 80 100	
															9.6	34.6 69.3	36 72	72.7 76.5 102.6	80 80 110	

See Legend and Notes on page 83.

Electrical data (cont)



50A2,A3,A4,A5 UNITS WITHOUT CONVENIENCE OUTLET (cont)

UNIT SIZE 50A	VOLTAGE 3 PH, 60 Hz	VOLTAGE RANGE		COMPRESSOR								CONDENSER FAN MOTOR		EVAPORATOR FAN MOTOR		POWER EXHAUST	OPTIONAL ELECTRIC HEAT		POWER SUPPLY	
				Cir A, No. 1		Cir A, No. 2		Cir B, No. 1		Cir B, No. 2		Qty	FLA	Hp	FLA	FLA (total)	FLA	kW	MCA	MOCPS*
		Min	Max	RLA	LRA	RLA	LRA	RLA	LRA	RLA	LRA	RLA	LRA							
027	208	187	229	27.6	191	27.6	191	27.6	191	—	—	2	6.5 (ea)	10	30.8	—	—	—	134.3	150
																75.1	27	134.3	150	
																150.1	54	188.6	200	
																23.6	—	—	157.9	175
																75.1	27	161.9	175	
																150.1	54	218.1	225	
	230	207	253	27.6	191	27.6	191	27.6	191	—	—	2	6.6 (ea)	15	46.2	—	—	—	153.6	175
																75.1	27	153.6	175	
																150.1	54	207.9	250	
																23.6	—	—	177.2	200
																75.1	27	181.1	200	
																150.1	54	237.4	250	
230	207	253	27.6	191	27.6	191	27.6	191	—	—	2	6.6 (ea)	20	59.4	—	—	—	170.1	225	
															75.1	27	170.1	225		
															150.1	54	224.4	250		
															23.6	—	—	193.7	250	
															75.1	27	197.6	250		
															150.1	54	253.9	300		
027	380	342	418	16.7	123	16.7	123	16.7	123	—	—	2	3.6 (ea)	10	16.7	—	—	—	78.2	90
																34.2	23	78.2	90	
																68.4	45	106.4	110	
																14.8	—	—	93.0	100
																34.2	23	93.0	100	
																68.4	45	124.9	125	
	380	342	418	16.7	123	16.7	123	16.7	123	—	—	2	3.6 (ea)	15	24.5	—	—	—	87.9	110
																34.2	23	87.9	110	
																68.4	45	116.1	125	
																14.8	—	—	102.7	125
																34.2	23	102.7	125	
																68.4	45	134.6	150	
380	342	418	16.7	123	16.7	123	16.7	123	—	—	2	3.6 (ea)	20	30.0	—	—	—	94.8	110	
															34.2	23	94.8	110		
															68.4	45	123.0	125		
															14.8	—	—	109.6	125	
															34.2	23	109.6	125		
															68.4	45	141.5	150		
027	460	414	508	12.8	100	12.8	100	12.8	100	—	—	2	3.3 (ea)	10	14.0	—	—	—	62.5	70
																43.3	36	71.6	80	
																86.6	72	104.1	110	
																12.6	—	—	75.1	80
																43.3	36	87.4	90	
																86.6	72	119.9	125	
	460	414	508	12.8	100	12.8	100	12.8	100	—	—	2	3.3 (ea)	15	21.0	—	—	—	71.3	90
																43.3	36	80.4	90	
																86.6	72	112.9	125	
																12.6	—	—	83.9	100
																43.3	36	96.1	100	
																86.6	72	128.6	150	
460	414	508	12.8	100	12.8	100	12.8	100	—	—	2	3.3 (ea)	20	27.0	—	—	—	78.8	100	
															43.3	36	87.9	100		
															86.6	72	120.4	125		
															12.6	—	—	91.4	110	
															43.3	36	103.6	110		
															86.6	72	136.1	150		
027	575	518	632	12.2	80	12.2	80	12.2	80	—	—	2	2.6 (ea)	10	11.0	—	—	—	55.9	60
																34.6	36	57.0	60	
																69.3	72	83.1	90	
																9.6	—	—	65.5	70
																34.6	36	69.0	70	
																69.3	72	95.1	100	
	575	518	632	12.2	80	12.2	80	12.2	80	—	—	2	2.6 (ea)	15	17.0	—	—	—	63.1	80
																34.6	36	64.5	80	
																69.3	72	90.6	100	
																9.6	—	—	72.7	80
																34.6	36	76.5	80	
																69.3	72	102.6	110	
575	518	632	12.2	80	12.2	80	12.2	80	—	—	2	2.6 (ea)	20	22.0	—	—	—	69.3	90	
															34.6	36	70.8	90		
															69.3	72	96.8	110		
															9.6	—	—	78.9	100	
															34.6	36	82.8	100		
															69.3	72	108.8	125		

See Legend and Notes on page 83.

50A2,A3,A4,A5 UNITS WITHOUT CONVENIENCE OUTLET (cont)

UNIT SIZE 50A	VOLTAGE 3 PH, 60 Hz	VOLTAGE RANGE		COMPRESSOR								CONDENSER FAN MOTOR		EVAPORATOR FAN MOTOR		POWER EXHAUST	OPTIONAL ELECTRIC HEAT			POWER SUPPLY	
				Cir A, No. 1		Cir A, No. 2		Cir B, No. 1		Cir B, No. 2											
		Min	Max	RLA	LRA	RLA	LRA	RLA	LRA	RLA	LRA	Qty	FLA	FLA (total)	FLA	kW	MCA	MOCP*			
030	208	187	229	23.2	164	23.2	164	23.2	164	23.2	164	2	6.5 (ea)	10	30.8	—	75.1	27	144.3	175	
																—	150.1	54	144.3	200	
																23.6	75.1	27	167.9	175	
																—	150.1	54	167.9	225	
																—	75.1	27	163.6	200	
																—	150.1	54	163.6	250	
	23.6	75.1	27	187.2	225																
	—	150.1	54	187.2	250																
	23.6	75.1	27	203.7	225																
	—	150.1	54	203.7	250																
	23.6	75.1	27	237.4	250																
	—	150.1	54	237.4	300																
230	207	253	23.2	164	23.2	164	23.2	164	23.2	164	2	6.6 (ea)	10	28.0	—	86.6	36	141.0	150		
															—	173.2	72	143.3	225		
															23.6	86.6	36	164.6	175		
															—	173.2	72	164.6	250		
															—	86.6	36	158.5	200		
															—	173.2	72	158.5	250		
23.6	86.6	36	182.1	200																	
—	173.2	72	182.1	250																	
23.6	86.6	36	190.3	200																	
—	173.2	72	190.3	300																	
23.6	86.6	36	225.2	225																	
—	173.2	72	225.2	250																	
23.6	86.6	36	255.2	300																	
—	173.2	72	255.2	300																	
380	342	418	12.2	73	12.2	73	12.2	73	12.2	73	2	3.6 (ea)	10	16.7	—	34.2	23	76.9	90		
															—	68.4	45	76.9	110		
															14.8	34.2	23	91.7	100		
															—	68.4	45	91.7	125		
															—	34.2	23	86.6	110		
															—	68.4	45	86.6	125		
14.8	34.2	23	101.4	125																	
—	68.4	45	101.4	150																	
—	34.2	23	93.5	110																	
—	68.4	45	93.5	110																	
14.8	34.2	23	123.0	125																	
—	68.4	45	123.0	125																	
14.8	34.2	23	108.3	125																	
—	68.4	45	108.3	150																	
14.8	34.2	23	141.5	150																	
—	68.4	45	141.5	150																	
460	414	508	11.2	75	11.2	75	11.2	75	11.2	75	2	3.3 (ea)	10	14.0	—	43.3	36	68.9	80		
															—	86.6	72	71.6	80		
															12.6	43.3	36	81.5	90		
															—	86.6	72	81.5	125		
															—	43.3	36	77.7	90		
															—	86.6	72	77.7	125		
12.6	43.3	36	90.3	110																	
—	86.6	72	90.3	150																	
—	43.3	36	96.1	110																	
—	86.6	72	96.1	150																	
—	43.3	36	85.2	110																	
—	86.6	72	85.2	110																	
12.6	43.3	36	87.9	110																	
—	86.6	72	87.9	125																	
12.6	43.3	36	103.6	110																	
—	86.6	72	103.6	150																	
12.6	43.3	36	97.8	110																	
—	86.6	72	97.8	110																	
12.6	43.3	36	103.6	110																	
—	86.6	72	103.6	150																	
575	518	632	7.9	54	7.9	54	7.9	54	7.9	54	2	2.6 (ea)	10	11.0	—	34.6	36	50.6	60		
															—	69.3	72	57.0	60		
															9.6	34.6	36	60.2	70		
															—	69.3	72	60.2	100		
															—	34.6	36	58.1	70		
															—	69.3	72	58.1	100		
9.6	34.6	36	67.7	80																	
—	69.3	72	67.7	110																	
—	34.6	36	76.5	80																	
—	69.3	72	76.5	110																	
—	34.6	36	64.3	80																	
—	69.3	72	64.3	80																	
9.6	34.6	36	70.8	80																	
—	69.3	72	70.8	110																	
9.6	34.6	36	73.9	90																	
—	69.3	72	73.9	90																	
9.6	34.6	36	82.8	90																	
—	69.3	72	82.8	125																	

See Legend and Notes on page 83.

Electrical data (cont)



50A2,A3,A4,A5 UNITS WITHOUT CONVENIENCE OUTLET (cont)

UNIT SIZE 50A	VOLTAGE 3 PH, 60 Hz	VOLTAGE RANGE		COMPRESSOR								CONDENSER FAN MOTOR		EVAPORATOR FAN MOTOR		POWER EXHAUST	OPTIONAL ELECTRIC HEAT		POWER SUPPLY	
				Cir A, No. 1		Cir A, No. 2		Cir B, No. 1		Cir B, No. 2							FLA	kW	MCA	MOCPS*
		Min	Max	RLA	LRA	RLA	LRA	RLA	LRA	RLA	LRA	Qty	FLA	Hp	FLA	FLA (total)	FLA	kW	MCA	MOCPS*
035	208	187	229	22.4	149	22.4	149	28.2	239	28.2	239	2	6.5 (ea)	15	46.2	—	75.1	27	172.0	200
																—	150.1	54	172.0	200
																23.6	75.1	27	195.6	225
																—	150.1	54	195.6	225
																—	75.1	27	207.7	250
																—	150.1	54	207.7	250
	20	59.4	—	75.1	27	188.5	225													
			—	150.1	54	188.5	225													
			23.6	75.1	27	212.1	250													
			—	150.1	54	212.1	250													
			—	75.1	27	231.3	300													
			—	150.1	54	231.3	300													
25	74.8	—	75.1	27	207.7	250														
		—	150.1	54	207.7	250														
		23.6	75.1	27	243.6	300														
		—	150.1	54	243.6	300														
		—	75.1	27	273.1	300														
		—	150.1	54	273.1	300														
035	230	207	253	22.4	149	22.4	149	28.2	239	28.2	239	2	6.6 (ea)	15	42.0	—	86.6	36	166.9	200
																—	173.2	72	166.9	200
																23.6	86.6	36	190.5	225
																—	173.2	72	190.5	225
																—	86.6	36	255.2	300
																—	173.2	72	255.2	300
	20	54.0	—	86.6	36	181.9	225													
			—	173.2	72	181.9	225													
			23.6	86.6	36	205.5	250													
			—	173.2	72	205.5	250													
			—	86.6	36	270.2	300													
			—	173.2	72	270.2	300													
25	68.0	—	86.6	36	199.4	250														
		—	173.2	72	199.4	250														
		23.6	86.6	36	258.2	300														
		—	173.2	72	258.2	300														
		—	86.6	36	223.0	250														
		—	173.2	72	223.0	250														
035	380	342	418	11	88	11	88	16	135	16	135	2	3.6 (ea)	15	24.5	—	34.2	23	91.8	110
																—	68.4	45	91.8	110
																14.8	34.2	23	106.6	125
																—	68.4	45	106.6	125
																—	34.2	23	134.6	150
																—	68.4	45	134.6	150
	20	30.0	—	34.2	23	98.7	125													
			—	68.4	45	98.7	125													
			14.8	34.2	23	113.5	125													
			—	68.4	45	113.5	125													
			—	34.2	23	141.5	150													
			—	68.4	45	141.5	150													
25	38.0	—	34.2	23	108.7	125														
		—	68.4	45	108.7	125														
		14.8	34.2	23	133.0	150														
		—	68.4	45	133.0	150														
		—	34.2	23	123.5	150														
		—	68.4	45	123.5	150														
035	460	414	508	10.6	75	10.6	75	14.7	130	14.7	130	2	3.3 (ea)	15	21.0	—	43.3	36	83.5	100
																—	86.6	72	83.5	100
																12.6	43.3	36	91.0	110
																—	86.6	72	91.0	110
																—	43.3	36	128.6	150
																—	86.6	72	128.6	150
	20	27.0	—	43.3	36	91.0	110													
			—	86.6	72	91.0	110													
			12.6	43.3	36	103.6	125													
			—	86.6	72	103.6	125													
			—	43.3	36	136.1	150													
			—	86.6	72	136.1	150													
25	34.0	—	43.3	36	99.7	125														
		—	86.6	72	99.7	125														
		12.6	43.3	36	129.1	150														
		—	86.6	72	129.1	150														
		—	43.3	36	112.3	125														
		—	86.6	72	112.3	125														
035	575	518	632	7.7	54	7.7	54	11.3	93.7	11.3	93.7	2	2.6 (ea)	15	17.0	—	34.6	36	64.5	80
																—	69.3	72	64.5	80
																9.6	34.6	36	74.1	90
																—	69.3	72	74.1	90
																—	34.6	36	102.6	110
																—	69.3	72	102.6	110
	20	22.0	—	34.6	36	70.7	90													
			—	69.3	72	70.7	90													
			9.6	34.6	36	96.8	110													
			—	69.3	72	96.8	110													
			—	34.6	36	80.3	100													
			—	69.3	72	80.3	100													
25	27.0	—	34.6	36	77.0	100														
		—	69.3	72	77.0	100														
		9.6	34.6	36	103.1	125														
		—	69.3	72	103.1	125														
		—	34.6	36	86.6	110														
		—	69.3	72	86.6	110														

See Legend and Notes on page 83.

50A2,A3,A4,A5 UNITS WITHOUT CONVENIENCE OUTLET (cont)

UNIT SIZE 50A	VOLTAGE 3 PH, 60 Hz	VOLTAGE RANGE		COMPRESSOR								CONDENSER FAN MOTOR		EVAPORATOR FAN MOTOR		POWER EXHAUST	OPTIONAL ELECTRIC HEAT		POWER SUPPLY			
				Cir A, No. 1		Cir A, No. 2		Cir B, No. 1		Cir B, No. 2												
		Min	Max	RLA	LRA	RLA	LRA	RLA	LRA	RLA	LRA	Qty	FLA	FLA	FLA	FLA (total)	FLA	KW	MCA	MOCPS*		
040	208	187	229	28.2	239	28.2	239	28.2	239	28.2	239	4	6.5 (ea)	15	46.2	—	75.1	27	196.6	225		
																—	150.1	54	196.6	225		
																23.6	75.1	27	220.2	250		
																—	150.1	54	220.2	250		
																—	75.1	27	213.1	250		
																23.6	75.1	27	236.7	250		
	—	150.1	54	237.4	250																	
	230	207	253	28.2	239	28.2	239	28.2	239	28.2	239	28.2	239	4	6.6 (ea)	15	42.0	—	86.6	36	191.7	225
																		—	173.2	72	191.7	225
																		23.6	86.6	36	215.3	250
																		—	173.2	72	215.3	250
																		—	86.6	36	206.7	250
23.6																		86.6	36	230.3	250	
—	173.2	72	270.2	300																		
380	342	418	16.0	135	16.0	135	16.0	135	16.0	135	16.0	135	4	3.6 (ea)	15	24.5	—	34.2	23	109.0	125	
																	—	68.4	45	109.0	125	
																	14.8	34.2	23	123.8	125	
																	—	68.4	45	123.8	125	
																	—	34.2	23	115.9	125	
																	14.8	34.2	23	130.7	150	
—	68.4	45	141.5	150																		
460	414	508	14.7	130	14.7	130	14.7	130	14.7	130	14.7	130	4	3.3 (ea)	15	21.0	—	43.3	36	98.3	110	
																	—	86.6	72	98.3	110	
																	12.6	43.3	36	110.9	125	
																	—	86.6	72	110.9	125	
																	—	43.3	36	105.8	125	
																	12.6	43.3	36	105.8	125	
—	86.6	72	120.4	125																		
575	518	632	11.3	93.7	11.3	93.7	11.3	93.7	11.3	93.7	11.3	93.7	4	2.6 (ea)	15	17.0	—	34.6	36	76.9	90	
																	—	69.3	72	76.9	90	
																	9.6	34.6	36	86.5	100	
																	—	69.3	72	86.5	100	
																	—	34.6	36	83.1	100	
																	9.6	34.6	36	83.1	100	
—	69.3	72	96.8	110																		
50A2	518	632	11.3	93.7	11.3	93.7	11.3	93.7	11.3	93.7	11.3	93.7	4	2.6 (ea)	20	22.0	—	34.6	36	92.7	110	
																	—	69.3	72	92.7	110	
																	9.6	34.6	36	92.7	110	
																	—	69.3	72	92.7	110	
																	—	34.6	36	89.4	110	
																	9.6	34.6	36	89.4	110	
—	69.3	72	103.1	125																		
50A3	518	632	11.3	93.7	11.3	93.7	11.3	93.7	11.3	93.7	11.3	93.7	4	2.6 (ea)	25	27.0	—	34.6	36	99.0	125	
																	—	69.3	72	99.0	125	
																	9.6	34.6	36	99.0	125	
																	—	69.3	72	99.0	125	
																	—	34.6	36	89.4	110	
																	9.6	34.6	36	89.4	110	
—	69.3	72	103.1	125																		

See Legend and Notes on page 83.

Electrical data (cont)



50A2,A3,A4,A5 UNITS WITHOUT CONVENIENCE OUTLET (cont)

UNIT SIZE 50A	VOLTAGE 3 PH, 60 Hz	VOLTAGE RANGE		COMPRESSOR								CONDENSER FAN MOTOR		EVAPORATOR FAN MOTOR		POWER EXHAUST	OPTIONAL ELECTRIC HEAT		POWER SUPPLY	
				Cir A, No. 1		Cir A, No. 2		Cir B, No. 1		Cir B, No. 2							FLA (total)	FLA	KW	MCA
		Min	Max	RLA	LRA	RLA	LRA	RLA	LRA	RLA	LRA	Qty	FLA	Hp	FLA	FLA (total)	FLA	KW	MCA	MOCPS*
050	208	187	229	33.3	239	33.3	239	33.3	239	33.3	239	4	6.5 (ea)	20	59.0	—	75.1	27	233.5	250
																—	150.1	54	233.5	250
																23.6	75.1	27	257.1	300
																—	150.1	54	257.1	300
																—	75.1	27	252.7	300
																—	150.1	54	252.7	300
	25	75.0	—	75.1	27	276.3	350													
			—	150.1	54	276.3	350													
			23.6	75.1	27	276.3	350													
			—	150.1	54	276.3	350													
			—	75.1	27	269.2	350													
			—	150.1	54	269.2	350													
30	88.0	—	75.1	27	292.8	350														
		—	150.1	54	292.8	350														
		23.6	75.1	27	292.8	350														
		—	150.1	54	292.8	350														
		—	75.1	27	227.1	250														
		—	150.1	54	227.1	250														
050	230	207	253	33.3	239	33.3	239	33.3	239	33.3	239	4	6.6 (ea)	20	54.0	—	86.6	36	227.1	250
																—	173.2	72	240.7	250
																23.6	86.6	36	250.7	300
																—	173.2	72	250.7	300
																—	86.6	36	244.6	300
																—	173.2	72	244.6	300
	25	68.0	—	86.6	36	268.2	300													
			—	173.2	72	268.2	300													
			23.6	86.6	36	268.2	300													
			—	173.2	72	268.2	300													
			—	86.6	36	259.6	300													
			—	173.2	72	259.6	300													
30	80.0	—	86.6	36	283.2	350														
		—	173.2	72	283.2	350														
		23.6	86.6	36	283.2	350														
		—	173.2	72	283.2	350														
		—	86.6	36	146.7	175														
		—	173.2	72	146.7	175														
050	380	342	418	23.7	145	23.7	145	23.7	145	23.7	145	4	3.6 (ea)	20	30.0	—	34.2	23	146.7	175
																—	68.4	45	146.7	175
																14.8	34.2	23	161.5	175
																—	68.4	45	161.5	175
																—	34.2	23	156.7	175
																—	68.4	45	156.7	175
	25	38.0	—	34.2	23	171.5	200													
			—	68.4	45	171.5	200													
			14.8	34.2	23	171.5	200													
			—	68.4	45	171.5	200													
			—	34.2	23	163.6	200													
			—	68.4	45	163.6	200													
30	43.5	—	34.2	23	178.4	200														
		—	68.4	45	178.4	200														
		14.8	34.2	23	178.4	200														
		—	68.4	45	178.4	200														
		—	43.3	36	118.6	125														
		—	86.6	72	118.6	125														
050	460	414	508	17.9	125	17.9	125	17.9	125	17.9	125	4	3.3 (ea)	20	27.0	—	43.3	36	131.2	150
																—	86.6	72	131.2	150
																12.6	43.3	36	136.1	150
																—	86.6	72	136.1	150
																—	43.3	36	127.3	150
																—	86.6	72	127.3	150
	25	34.0	—	43.3	36	139.9	150													
			—	86.6	72	139.9	150													
			12.6	43.3	36	144.9	175													
			—	86.6	72	144.9	175													
			—	43.3	36	134.8	150													
			—	86.6	72	134.8	150													
30	40.0	—	43.3	36	147.4	175														
		—	86.6	72	147.4	175														
		12.6	43.3	36	152.4	175														
		—	86.6	72	152.4	175														
		—	34.6	36	89.1	110														
		—	69.3	72	89.1	110														
050	575	518	632	12.8	80	12.8	80	12.8	80	12.8	80	4	2.6 (ea)	20	22.0	—	34.6	36	98.7	110
																—	69.3	72	98.7	110
																9.6	34.6	36	108.8	125
																—	69.3	72	108.8	125
																—	34.6	36	95.4	110
																—	69.3	72	95.4	110
	25	27.0	—	34.6	36	105.0	125													
			—	69.3	72	105.0	125													
			9.6	34.6	36	115.1	125													
			—	69.3	72	115.1	125													
			—	34.6	36	101.6	125													
			—	69.3	72	101.6	125													
30	32.0	—	34.6	36	111.2	125														
		—	69.3	72	111.2	125														
		9.6	34.6	36	121.3	150														
		—	69.3	72	121.3	150														

See Legend and Notes on page 83.

50A2,A3,A4,A5 UNITS WITHOUT CONVENIENCE OUTLET (cont)

UNIT SIZE 50A	VOLTAGE 3 PH, 60 Hz	VOLTAGE RANGE		COMPRESSOR								CONDENSER FAN MOTOR		EVAPORATOR FAN MOTOR		POWER EXHAUST	OPTIONAL ELECTRIC HEAT		POWER SUPPLY		
		Min	Max	Cir A, No. 1		Cir A, No. 2		Cir B, No. 1		Cir B, No. 2		Qty	FLA	Hp	FLA	FLA (total)	FLA	kW	MCA	MOCP*	
				RLA	LRA	RLA	LRA	RLA	LRA	RLA	LRA										
060 (MCHX)	208	187	229	51.3	300	51.3	300	51.3	300	51.3	300	4	5.5 (ea)	25	74.8	—	—	—	320.7	350	
																112.6	41	—	320.7	350	
		225.2	81	—	320.7	350															
		35.4	—	—	356.1	400															
		112.6	41	—	356.1	400															
		225.2	81	—	363.0	400															
	208	187	229	51.3	300	51.3	300	51.3	300	51.3	300	4	5.5 (ea)	30	88.0	—	—	—	337.2	400	
																112.6	41	—	337.2	400	
	225.2	81	—	337.2	400																
	35.4	—	—	372.6	450																
	112.6	41	—	372.6	450																
	225.2	81	—	379.5	450																
208	187	229	51.3	300	51.3	300	51.3	300	51.3	300	4	5.5 (ea)	40	114.0	—	—	—	369.7	450		
															112.6	41	—	369.7	450		
225.2	81	—	369.7	450																	
35.4	—	—	405.1	500																	
112.6	41	—	405.1	500																	
225.2	81	—	412.0	500																	
230	207	253	51.3	300	51.3	300	51.3	300	51.3	300	4	5.8 (ea)	25	68.0	—	—	—	313.4	350		
															129.9	54	—	313.4	350		
	259.8	108	—	344.8	400																
	35.4	—	—	348.8	400																
	129.9	54	—	348.8	400																
	259.8	108	—	389.1	400																
230	207	253	51.3	300	51.3	300	51.3	300	51.3	300	4	5.8 (ea)	30	80.0	—	—	—	328.4	400		
															129.9	54	—	328.4	400		
259.8	108	—	328.4	400																	
35.4	—	—	363.8	400																	
129.9	54	—	363.8	400																	
259.8	108	—	404.1	450																	
230	207	253	51.3	300	51.3	300	51.3	300	51.3	300	4	5.8 (ea)	40	104.0	—	—	—	358.4	450		
															129.9	54	—	358.4	450		
259.8	108	—	389.8	450																	
35.4	—	—	393.8	450																	
129.9	54	—	393.8	450																	
259.8	108	—	434.1	500																	
380	342	418	26.9	139	26.9	139	26.9	139	26.9	139	26.9	139	4	3.7 (ea)	25	38.0	—	—	—	169.9	200
																	51.4	33.8	—	169.9	200
	102.8	67.7	—	169.9	200																
	22.2	—	—	192.1	225																
	51.4	33.8	—	192.1	225																
	102.8	67.7	—	192.1	225																
380	342	418	26.9	139	26.9	139	26.9	139	26.9	139	26.9	139	4	3.7 (ea)	30	43.5	—	—	—	176.8	200
																	51.4	33.8	—	176.8	200
102.8	67.7	—	176.8	200																	
22.2	—	—	199.0	225																	
51.4	33.8	—	199.0	225																	
102.8	67.7	—	199.0	225																	
380	342	418	26.9	139	26.9	139	26.9	139	26.9	139	26.9	139	4	3.7 (ea)	40	56.2	—	—	—	192.7	225
																	51.4	33.8	—	192.7	225
102.8	67.7	—	192.7	225																	
22.2	—	—	214.9	250																	
51.4	33.8	—	214.9	250																	
102.8	67.7	—	214.9	250																	
460	414	508	22.4	150	22.4	150	22.4	150	22.4	150	22.4	150	4	2.9 (ea)	25	34.0	—	—	—	143.7	175
																	65.0	54	—	143.7	175
	129.9	108	—	172.4	200																
	18.9	—	—	162.6	175																
	65.0	54	—	162.6	175																
	129.9	108	—	196.0	225																
460	414	508	22.4	150	22.4	150	22.4	150	22.4	150	22.4	150	4	2.9 (ea)	30	40.0	—	—	—	151.2	175
																	65.0	54	—	151.2	175
129.9	108	—	151.2	175																	
18.9	—	—	170.1	200																	
65.0	54	—	170.1	200																	
129.9	108	—	203.5	225																	
460	414	508	22.4	150	22.4	150	22.4	150	22.4	150	22.4	150	4	2.9 (ea)	40	52.0	—	—	—	166.2	200
																	65.0	54	—	166.2	200
129.9	108	—	166.2	200																	
18.9	—	—	194.9	225																	
65.0	54	—	185.1	225																	
129.9	108	—	185.1	225																	
218.5	—	—	218.5	250																	
575	518	632	19.9	109	19.9	109	19.9	109	19.9	109	19.9	109	4	2.3 (ea)	25	27.0	—	—	—	122.6	125
																	65.0	54	—	122.6	125
	129.9	108	—	137.7	150																
	14.4	—	—	137.0	150																
	65.0	54	—	137.0	150																
	129.9	108	—	155.7	175																
575	518	632	19.9	109	19.9	109	19.9	109	19.9	109	19.9	109	4	2.3 (ea)	30	32.0	—	—	—	128.8	150
																	65.0	54	—	128.8	150
129.9	108	—	128.8	150																	
14.4	—	—	143.2	175																	
65.0	54	—	143.2	175																	
129.9	108	—	161.9	175																	
575	518	632	19.9	109	19.9	109	19.9	109	19.9	109	19.9	109	4	2.3 (ea)	40	41.0	—	—	—	140.1	175
																	65.0	54	—	140.1	175
129.9	108	—	140.1	175																	
14.4	—	—	154.5	175																	
65.0	54	—	154.5	175																	
129.9	108	—	173.2	200																	

See Legend and Notes on page 83.

Electrical data (cont)



50A2,A3,A4,A5 UNITS WITHOUT CONVENIENCE OUTLET (cont)

UNIT SIZE 50A	VOLTAGE 3 PH, 60 Hz	VOLTAGE RANGE		COMPRESSOR								CONDENSER FAN MOTOR		EVAPORATOR FAN MOTOR		POWER EXHAUST	OPTIONAL ELECTRIC HEAT		POWER SUPPLY	
				Cir A, No. 1		Cir A, No. 2		Cir B, No. 1		Cir B, No. 2							FLA	kW	MCA	MOCP*
		Min	Max	RLA	LRA	RLA	LRA	RLA	LRA	RLA	LRA	Qty	FLA	Hp	FLA	FLA (total)	FLA	kW	MCA	MOCP*
060 (RTPF)	208	187	229	51.3	300	51.3	300	51.3	300	51.3	300	6	6.5 (ea)	25	74.8	—	112.6	41	333.7	400
																—	225.2	81	333.7	400
																35.4	112.6	41	373.1	400
																—	225.2	81	373.0	400
																—	112.6	41	354.2	400
																—	225.2	81	354.2	400
	30	88.0	—	112.6	41	389.6	450													
			—	225.2	81	389.6	450													
			35.4	112.6	41	389.6	450													
			—	225.2	81	389.6	450													
			—	112.6	41	386.7	500													
			—	225.2	81	386.7	500													
	40	114.0	—	112.6	41	422.1	500													
			—	225.2	81	422.1	500													
			35.4	112.6	41	422.1	500													
			—	225.2	81	422.1	500													
			—	112.6	41	329.8	350													
			—	225.2	81	329.8	350													
	230	207	253	51.3	300	51.3	300	51.3	300	51.3	300	6	6.6 (ea)	25	68.0	—	129.9	54	329.8	350
																—	259.8	108	344.8	400
																35.4	129.9	54	365.2	400
																—	259.8	108	365.2	400
																—	129.9	54	344.8	400
																—	259.8	108	344.8	400
30	80.0	—	129.9	54	380.2	450														
		—	259.8	108	380.2	450														
		35.4	129.9	54	380.2	450														
		—	259.8	108	380.2	450														
		—	129.9	54	374.8	450														
		—	259.8	108	374.8	450														
40	104.0	—	129.9	54	410.2	500														
		—	259.8	108	410.2	500														
		35.4	129.9	54	410.2	500														
		—	259.8	108	410.2	500														
		—	129.9	54	374.8	450														
		—	259.8	108	374.8	450														
380	342	418	26.9	139	26.9	139	26.9	139	26.9	139	6	3.6 (ea)	25	38.0	—	51.4	33.8	151.9	175	
															—	102.8	67.7	172.4	200	
															22.2	51.4	33.8	170.8	200	
															—	102.8	67.7	170.8	200	
															—	51.4	33.8	159.4	175	
															—	102.8	67.7	159.4	175	
30	43.5	—	51.4	33.8	178.3	200														
		—	102.8	67.7	178.3	200														
		22.2	51.4	33.8	178.3	200														
		—	102.8	67.7	203.5	225														
		—	51.4	33.8	174.4	225														
		—	102.8	67.7	174.4	225														
40	56.2	—	51.4	33.8	193.3	225														
		—	102.8	67.7	193.3	225														
		22.2	51.4	33.8	193.3	225														
		—	102.8	67.7	218.5	250														
		—	51.4	33.8	151.9	175														
		—	102.8	67.7	151.9	175														
460	414	508	22.4	150	22.4	150	22.4	150	22.4	150	6	3.3 (ea)	25	34.0	—	65.0	54	151.9	175	
															—	129.9	108	172.4	200	
															18.9	65.0	54	170.8	200	
															—	129.9	108	170.8	200	
															—	65.0	54	159.4	175	
															—	129.9	108	159.4	175	
30	40.0	—	65.0	54	178.3	200														
		—	129.9	108	178.3	200														
		18.9	65.0	54	178.3	200														
		—	129.9	108	203.5	225														
		—	65.0	54	174.4	225														
		—	129.9	108	174.4	225														
40	52.0	—	65.0	54	193.3	225														
		—	129.9	108	193.3	225														
		18.9	65.0	54	193.3	225														
		—	129.9	108	218.5	250														
		—	65.0	54	129.0	150														
		—	129.9	108	129.0	150														
575	518	632	19.9	109	19.9	190	19.9	109	19.9	109	6	2.6 (ea)	25	27.0	—	52.0	54	129.0	150	
															—	103.9	108	137.7	150	
															14.4	52.0	54	143.4	150	
															—	103.9	108	143.4	150	
															—	52.0	54	135.2	150	
															—	103.9	108	135.2	150	
30	32.0	—	52.0	54	149.6	175														
		—	103.9	108	149.6	175														
		14.4	52.0	54	149.6	175														
		—	103.9	108	149.6	175														
		—	52.0	54	146.5	175														
		—	103.9	108	146.5	175														
40	41.0	—	52.0	54	160.9	200														
		—	103.9	108	160.9	200														
		14.4	52.0	54	160.9	200														
		—	103.9	108	160.9	200														
		—	52.0	54	173.2	200														
		—	103.9	108	173.2	200														

See Legend and Notes on page 83.

50A2,A3,A4,A5 UNITS WITH CONVENIENCE OUTLET

UNIT SIZE 50A	VOLTAGE 3 PH, 60 Hz	VOLTAGE RANGE		COMPRESSOR								CONDENSER FAN MOTOR		EVAPORATOR FAN MOTOR		POWER EXHAUST	CONVENIENCE OUTLET	OPTIONAL ELECTRIC HEAT		POWER SUPPLY	
		Min	Max	Cir A, No. 1		Cir A, No. 2		Cir B, No. 1		Cir B, No. 2		Qty	FLA	Hp	FLA	FLA (total)	FLA	FLA	kW	MCA	MOCP*
		RLA	LRA	RLA	LRA	RLA	LRA	RLA	LRA	Qty	FLA	FLA	FLA	FLA	FLA	FLA	FLA	kW	MCA	MOCP*	
020	208	187	229	22.4	149	22.4	149	27.6	191	—	—	2	6.5 (ea)	5	16.7	—	7.0	—	—	116.0	125
																—	7.0	75.1	27	123.5	125
																—	7.0	150.1	54	179.7	200
																23.6	7.0	—	—	139.6	150
																—	7.0	75.1	27	153.0	175
																—	7.0	150.1	54	209.2	225
		10	30.8	—	7.0	—	—	130.9	150												
				—	7.0	75.1	27	141.1	150												
				—	7.0	150.1	54	197.4	225												
				23.6	7.0	—	—	154.5	175												
				—	7.0	75.1	27	170.6	175												
				—	7.0	150.1	54	226.9	250												
	15	46.2	—	7.0	—	—	150.2	175													
			—	7.0	75.1	27	160.4	175													
			—	7.0	150.1	54	216.6	250													
			23.6	7.0	—	—	173.8	200													
			—	7.0	75.1	27	189.9	200													
			—	7.0	150.1	54	246.1	250													
	230	207	253	22.4	149	22.4	149	27.6	191	—	—	2	6.6 (ea)	5	15.2	—	7.0	—	—	114.7	125
																—	7.0	86.6	36	136.0	150
																—	7.0	173.2	72	201.0	225
																23.6	7.0	—	—	138.3	150
																—	7.0	86.6	36	165.5	175
																—	7.0	173.2	72	230.5	250
10		28.0	—	7.0	—	—	127.6	150													
			—	7.0	86.6	36	152.0	175													
			—	7.0	173.2	72	217.0	225													
			23.6	7.0	—	—	151.2	175													
			—	7.0	86.6	36	181.5	200													
			—	7.0	173.2	72	246.5	250													
15	42.0	—	7.0	—	—	145.1	175														
		—	7.0	86.6	36	169.5	175														
		—	7.0	173.2	72	234.5	250														
		23.6	7.0	—	—	168.7	200														
		—	7.0	86.6	36	199.0	200														
		—	7.0	173.2	72	264.0	300														
460	414	508	10.6	75	10.6	75	12.8	100	—	—	2	3.3 (ea)	5	7.6	—	3.5	—	—	54.9	60	
															—	3.5	43.3	36	68.0	70	
															—	3.5	86.6	72	100.5	110	
															12.6	3.5	—	—	67.5	80	
															—	3.5	43.3	36	83.8	90	
															—	3.5	86.6	72	116.2	125	
	10	14.0	—	3.5	—	—	61.6	70													
			—	3.5	43.3	36	76.0	80													
			—	3.5	86.6	72	108.5	110													
			12.6	3.5	—	—	74.2	80													
			—	3.5	43.3	36	91.8	100													
			—	3.5	86.6	72	124.2	125													
15	21.0	—	3.5	—	—	70.4	90														
		—	3.5	43.3	36	84.8	90														
		—	3.5	86.6	72	117.2	125														
		12.6	3.5	—	—	83.0	100														
		—	3.5	43.3	36	100.5	110														
		—	3.5	86.6	72	133.0	150														
575	518	632	7.7	54	7.7	54	12.2	80	—	—	2	2.6 (ea)	5	6.1	—	2.5	—	—	44.5	50	
															—	2.5	34.6	36	54.0	60	
															—	2.5	69.3	72	80.1	90	
															9.6	2.5	—	—	54.1	60	
															—	2.5	34.6	36	66.0	70	
															—	2.5	69.3	72	92.1	100	
	10	11.0	—	2.5	—	—	49.4	60													
			—	2.5	34.6	36	60.1	70													
			—	2.5	69.3	72	86.2	90													
			9.6	2.5	—	—	59.0	70													
			—	2.5	34.6	36	72.1	80													
			—	2.5	69.3	72	98.2	100													
15	17.0	—	2.5	—	—	56.6	70														
		—	2.5	34.6	36	67.6	70														
		—	2.5	69.3	72	93.7	110														
		9.6	2.5	—	—	66.2	80														
		—	2.5	34.6	36	79.6	80														
		—	2.5	69.3	72	105.7	110														

See Legend and Notes on page 83.

Electrical data (cont)



50A2,A3,A4,A5 UNITS WITH CONVENIENCE OUTLET (cont)

UNIT SIZE 50A	VOLTAGE 3 PH, 60 Hz	VOLTAGE RANGE		COMPRESSOR								CONDENSER FAN MOTOR		EVAPORATOR FAN MOTOR		POWER EXHAUST	CONVENIENCE OUTLET		OPTIONAL ELECTRIC HEAT		POWER SUPPLY	
		Min	Max	Cir A, No. 1		Cir A, No. 2		Cir B, No. 1		Cir B, No. 2		Qty	FLA	Hp	FLA	FLA (total)	FLA	FLA	FLA	kW	MCA	MOCP*
				RLA	LRA	RLA	LRA	RLA	LRA	RLA	LRA											
025	208	187	229	27.6	191	27.6	191	27.6	191	—	—	2	6.5 (ea)	5	16.7	—	7.0	—	—	126.4	150	
																7.0	75.1	27	126.4	150		
																7.0	150.1	54	179.7	200		
																23.6	7.0	—	—	150.0	175	
																7.0	75.1	27	153.0	175		
																7.0	150.1	54	209.2	225		
	10	30.8	—	7.0	—	—	141.3	150														
			7.0	75.1	27	141.3	150															
			7.0	150.1	54	197.4	225															
			23.6	7.0	—	—	164.9	175														
			7.0	75.1	27	170.6	175															
			7.0	150.1	54	226.9	250															
15	46.2	—	7.0	—	—	160.6	200															
		7.0	75.1	27	160.6	200																
		7.0	150.1	54	216.6	250																
		23.6	7.0	—	—	184.2	225															
		7.0	75.1	27	189.9	225																
		7.0	150.1	54	246.1	250																
025	230	207	253	27.6	191	27.6	191	27.6	191	—	—	2	6.6 (ea)	5	15.2	—	7.0	—	—	125.1	150	
																7.0	86.6	36	136.0	150		
																7.0	173.2	72	201.0	225		
																23.6	7.0	—	—	148.7	175	
																7.0	86.6	36	165.5	175		
																7.0	173.2	72	230.5	250		
	10	28.0	—	7.0	—	—	138.0	150														
			7.0	86.6	36	152.0	175															
			7.0	173.2	72	217.0	225															
			23.6	7.0	—	—	161.6	175														
			7.0	86.6	36	181.5	200															
			7.0	173.2	72	246.5	250															
15	42.0	—	7.0	—	—	155.5	175															
		7.0	86.6	36	169.5	175																
		7.0	173.2	72	234.5	250																
		23.6	7.0	—	—	179.1	200															
		7.0	86.6	36	199.0	200																
		7.0	173.2	72	264.0	300																
025	460	414	508	12.8	100	12.8	100	12.8	100	—	—	2	3.3 (ea)	5	7.6	—	3.5	—	—	59.3	70	
																3.5	43.3	36	68.0	70		
																3.5	86.6	72	100.5	110		
																12.6	3.5	—	—	71.9	80	
																3.5	43.3	36	83.8	90		
																3.5	86.6	72	116.2	125		
	10	14.0	—	3.5	—	—	66.0	80														
			3.5	43.3	36	76.0	80															
			3.5	86.6	72	108.5	110															
			12.6	3.5	—	—	78.6	90														
			3.5	43.3	36	91.8	100															
			3.5	86.6	72	124.2	125															
15	21.0	—	3.5	—	—	74.8	90															
		3.5	43.3	36	84.8	90																
		3.5	86.6	72	117.2	125																
		12.6	3.5	—	—	87.4	100															
		3.5	43.3	36	100.5	110																
		3.5	86.6	72	133.0	150																
025	575	518	632	12.2	80	12.2	80	12.2	80	—	—	2	2.6 (ea)	5	6.1	—	2.5	—	—	53.5	60	
																2.5	34.6	36	54.0	60		
																2.5	69.3	72	80.1	90		
																9.6	2.5	—	—	63.1	70	
																2.5	34.6	36	66.0	70		
																2.5	69.3	72	92.1	100		
	10	11.0	—	2.5	—	—	58.4	70														
			2.5	34.6	36	60.1	70															
			2.5	69.3	72	86.2	90															
			9.6	2.5	—	—	68.0	80														
			2.5	34.6	36	72.1	80															
			2.5	69.3	72	98.2	100															
15	17.0	—	2.5	—	—	65.6	80															
		2.5	34.6	36	67.6	80																
		2.5	69.3	72	93.7	110																
		9.6	2.5	—	—	75.2	90															
		2.5	34.6	36	79.6	90																
		2.5	69.3	72	105.7	110																

See Legend and Notes on page 83.

50A2,A3,A4,A5 UNITS WITH CONVENIENCE OUTLET (cont)

UNIT SIZE 50A	VOLTAGE 3 PH, 60 Hz	VOLTAGE RANGE		COMPRESSOR								CONDENSER FAN MOTOR		EVAPORATOR FAN MOTOR		POWER EXHAUST	CONVENIENCE OUTLET		OPTIONAL ELECTRIC HEAT		POWER SUPPLY	
		Min	Max	Cir A, No. 1		Cir A, No. 2		Cir B, No. 1		Cir B, No. 2		Qty	FLA	Hp	FLA	FLA (total)	FLA	FLA	kW	MCA	MOCP*	
		RLA	LRA	RLA	LRA	RLA	LRA	RLA	LRA	Qty	FLA	FLA	FLA	FLA	FLA	FLA	FLA	FLA	FLA	FLA	FLA	FLA
027	208	187	229	27.6	191	27.6	191	27.6	191	—	—	2	6.5 (ea)	10	30.8	—	7.0	—	—	141.3	150	
																—	7.0	75.1	27	141.3	150	
																—	7.0	150.1	54	197.4	225	
																23.6	7.0	—	—	164.9	175	
																—	7.0	75.1	27	170.6	175	
																—	7.0	150.1	54	226.9	250	
	15	46.2	—	7.0	—	—	160.6	200														
			—	7.0	75.1	27	160.6	200														
			—	7.0	150.1	54	216.6	250														
			23.6	7.0	—	—	184.2	225														
			—	7.0	75.1	27	189.9	225														
			—	7.0	150.1	54	246.1	250														
20	59.4	—	7.0	—	—	177.1	225															
		—	7.0	75.1	27	177.1	225															
		—	7.0	150.1	54	233.1	250															
		23.6	7.0	—	—	200.7	250															
		—	7.0	75.1	27	206.4	250															
		—	7.0	150.1	54	262.6	300															
027	230	207	253	27.6	191	27.6	191	27.6	191	—	—	2	6.6 (ea)	10	28.0	—	7.0	—	—	138.0	150	
																—	7.0	86.6	36	152.0	175	
																—	7.0	173.2	72	217.0	225	
																23.6	7.0	—	—	161.6	175	
																—	7.0	86.6	36	181.5	200	
																—	7.0	173.2	72	246.5	250	
	15	42.0	—	7.0	—	—	155.5	175														
			—	7.0	86.6	36	169.5	175														
			—	7.0	173.2	72	234.5	250														
			23.6	7.0	—	—	179.1	200														
			—	7.0	86.6	36	199.0	200														
			—	7.0	173.2	72	264.0	300														
20	54.0	—	7.0	—	—	170.5	200															
		—	7.0	86.6	36	184.5	200															
		—	7.0	173.2	72	249.5	300															
		23.6	7.0	—	—	194.1	225															
		—	7.0	86.6	36	214.0	225															
		—	7.0	173.2	72	279.0	300															
027	460	414	508	12.8	100	12.8	100	12.8	100	—	—	2	3.3 (ea)	10	14.0	—	3.5	—	—	66.0	80	
																—	3.5	43.3	36	76.0	80	
																—	3.5	86.6	72	108.5	110	
																12.6	3.5	—	—	78.6	90	
																—	3.5	43.3	36	91.8	100	
																—	3.5	86.6	72	124.2	125	
	15	21.0	—	3.5	—	—	74.8	90														
			—	3.5	43.3	36	84.8	90														
			—	3.5	86.6	72	117.2	125														
			12.6	3.5	—	—	87.4	100														
			—	3.5	43.3	36	100.5	110														
			—	3.5	86.6	72	133.0	150														
20	27.0	—	3.5	—	—	82.3	100															
		—	3.5	43.3	36	92.3	100															
		—	3.5	86.6	72	124.7	150															
		12.6	3.5	—	—	94.9	110															
		—	3.5	43.3	36	108.0	110															
		—	3.5	86.6	72	140.5	150															
027	575	518	632	12.2	80	12.2	80	12.2	80	—	—	2	2.6 (ea)	10	11.0	—	2.5	—	—	58.4	70	
																—	2.5	34.6	36	60.1	70	
																—	2.5	69.3	72	86.2	90	
																9.6	2.5	—	—	68.0	80	
																—	2.5	34.6	36	72.1	80	
																—	2.5	69.3	72	98.2	100	
	15	17.0	—	2.5	—	—	65.6	80														
			—	2.5	34.6	36	67.6	80														
			—	2.5	69.3	72	93.7	110														
			9.6	2.5	—	—	75.2	90														
			—	2.5	34.6	36	79.6	90														
			—	2.5	69.3	72	105.7	110														
20	22.0	—	2.5	—	—	71.8	90															
		—	2.5	34.6	36	73.9	90															
		—	2.5	69.3	72	99.9	110															
		9.6	2.5	—	—	81.4	100															
		—	2.5	34.6	36	85.9	100															
		—	2.5	69.3	72	111.9	125															

See Legend and Notes on page 83.

Electrical data (cont)



50A2,A3,A4,A5 UNITS WITH CONVENIENCE OUTLET (cont)

UNIT SIZE 50A	VOLTAGE 3 PH, 60 Hz	VOLTAGE RANGE		COMPRESSOR								CONDENSER FAN MOTOR		EVAPORATOR FAN MOTOR		POWER EXHAUST	CONVENIENCE OUTLET		OPTIONAL ELECTRIC HEAT		POWER SUPPLY		
		Min	Max	Cir A, No. 1		Cir A, No. 2		Cir B, No. 1		Cir B, No. 2		Qty	FLA	Hp	FLA	FLA (total)	FLA	FLA	FLA	kW	MCA	MOCP*	
				RLA	LRA	RLA	LRA	RLA	LRA	RLA	LRA												
030	208	187	229	23.2	164	23.2	164	23.2	164	23.2	164	2	6.5 (ea)	10	30.8	—	7.0	—	—	151.3	175		
																—	7.0	75.1	27	151.3	175		
																—	7.0	150.1	54	197.4	225		
																23.6	7.0	—	—	174.9	200		
																—	7.0	75.1	27	174.9	200		
																—	7.0	150.1	54	226.9	250		
	230	207	253	23.2	164	23.2	164	23.2	164	23.2	164	23.2	164	2	6.6 (ea)	10	28.0	—	7.0	—	—	148.0	175
																		—	7.0	86.6	36	152.0	175
																		—	7.0	173.2	72	217.0	225
																		23.6	7.0	—	—	171.6	175
																		—	7.0	86.6	36	181.5	200
																		—	7.0	173.2	72	246.5	250
460	414	508	11.2	75	11.2	75	11.2	75	11.2	75	11.2	75	2	3.3 (ea)	10	14.0	—	3.5	—	—	72.4	80	
																	—	3.5	43.3	36	76.0	80	
																	—	3.5	86.6	72	108.5	110	
																	12.6	3.5	—	—	85.0	90	
																	—	3.5	43.3	36	91.8	100	
																	—	3.5	86.6	72	124.2	125	
575	518	632	7.9	54	7.9	54	7.9	54	7.9	54	7.9	54	2	2.6 (ea)	10	11.0	—	2.5	—	—	53.1	60	
																	—	2.5	34.6	36	60.1	70	
																	—	2.5	69.3	72	86.2	90	
																	9.6	2.5	—	—	62.7	70	
																	—	2.5	34.6	36	72.1	80	
																	—	2.5	69.3	72	98.2	100	
575	518	632	7.9	54	7.9	54	7.9	54	7.9	54	7.9	54	2	2.6 (ea)	15	17.0	—	2.5	—	—	60.6	70	
																	—	2.5	34.6	36	67.6	70	
																	—	2.5	69.3	72	93.7	110	
																	9.6	2.5	—	—	70.2	80	
																	—	2.5	34.6	36	79.6	80	
																	—	2.5	69.3	72	105.7	110	
575	518	632	7.9	54	7.9	54	7.9	54	7.9	54	7.9	54	2	2.6 (ea)	20	22.0	—	2.5	—	—	66.8	80	
																	—	2.5	34.6	36	73.9	80	
																	—	2.5	69.3	72	99.9	110	
																	9.6	2.5	—	—	76.4	90	
																	—	2.5	34.6	36	85.9	90	
																	—	2.5	69.3	72	111.9	125	

See Legend and Notes on page 83.

50A2,A3,A4,A5 UNITS WITH CONVENIENCE OUTLET (cont)

UNIT SIZE 50A	VOLTAGE 3 PH, 60 Hz	VOLTAGE RANGE		COMPRESSOR								CONDENSER FAN MOTOR		EVAPORATOR FAN MOTOR		POWER EXHAUST	CONVENIENCE OUTLET		OPTIONAL ELECTRIC HEAT		POWER SUPPLY	
		Min	Max	Cir A, No. 1		Cir A, No. 2		Cir B, No. 1		Cir B, No. 2		Qty	FLA	Hp	FLA	FLA (total)	FLA	FLA	FLA	kW	MCA	MOCP*
		RLA	LRA	RLA	LRA	RLA	LRA	RLA	LRA	RLA	LRA											
035	208	187	229	22.4	149	22.4	149	28.2	239	28.2	239	2	6.5 (ea)	15	46.2	—	7.0	—	—	179.0	225	
																—	7.0	75.1	27	179.0	225	
																—	7.0	150.1	54	216.6	250	
																23.6	7.0	—	—	202.6	225	
																23.6	7.0	75.1	27	202.6	225	
																23.6	7.0	150.1	54	246.1	250	
																—	7.0	—	—	195.5	250	
																—	7.0	75.1	27	195.5	250	
																—	7.0	150.1	54	233.1	250	
	23.6	7.0	—	—	219.1	250																
	23.6	7.0	75.1	27	219.1	250																
	23.6	7.0	150.1	54	262.6	300																
	—	7.0	—	—	214.7	250																
	—	7.0	75.1	27	214.7	250																
	—	7.0	150.1	54	252.4	300																
	23.6	7.0	—	—	238.3	300																
	23.6	7.0	75.1	27	238.3	300																
	23.6	7.0	150.1	54	281.9	300																
	230	207	253	22.4	149	22.4	149	28.2	239	28.2	239	2	6.6 (ea)	15	42.0	—	7.0	—	—	173.9	200	
																—	7.0	86.6	36	173.9	200	
																—	7.0	173.2	72	234.5	250	
																23.6	7.0	—	—	197.5	225	
																23.6	7.0	86.6	36	199.0	225	
																23.6	7.0	173.2	72	264.0	300	
—																7.0	—	—	188.9	225		
—																7.0	86.6	36	188.9	225		
—																7.0	173.2	72	249.5	300		
23.6	7.0	—	—	212.5	250																	
23.6	7.0	86.6	36	214.0	250																	
23.6	7.0	173.2	72	279.0	300																	
—	7.0	—	—	206.4	250																	
—	7.0	86.6	36	206.4	250																	
—	7.0	173.2	72	267.0	300																	
23.6	7.0	—	—	230.0	250																	
23.6	7.0	86.6	36	231.5	250																	
23.6	7.0	173.2	72	296.5	350																	
460	414	508	10.6	75	10.6	75	14.7	130	14.7	130	2	3.3 (ea)	15	21.0	—	3.5	—	—	87.0	100		
															—	3.5	43.3	36	87.0	100		
															—	3.5	86.6	72	117.2	125		
															12.6	3.5	—	—	99.6	110		
															12.6	3.5	43.3	36	100.5	110		
															12.6	3.5	86.6	72	133.0	150		
													20	27.0	—	3.5	—	—	94.5	110		
															—	3.5	43.3	36	94.5	110		
															—	3.5	86.6	72	124.7	150		
															12.6	3.5	—	—	107.1	125		
															12.6	3.5	43.3	36	108.0	125		
															12.6	3.5	86.6	72	140.5	150		
25	34.0	—	3.5	—	—	103.2	125															
		—	3.5	43.3	36	103.2	125															
		—	3.5	86.6	72	133.5	150															
		12.6	3.5	—	—	115.8	125															
		12.6	3.5	43.3	36	116.8	125															
		12.6	3.5	86.6	72	149.2	175															
575	518	632	7.7	54	7.7	54	11.3	93.7	11.3	93.7	2	2.6 (ea)	15	17.0	—	2.5	—	—	67.0	80		
															—	2.5	34.6	36	67.6	80		
															—	2.5	69.3	72	93.7	110		
															9.6	2.5	—	—	76.6	90		
															9.6	2.5	34.6	36	79.6	90		
															9.6	2.5	69.3	72	105.7	110		
													20	22.0	—	2.5	—	—	73.2	90		
															—	2.5	34.6	36	73.9	90		
															—	2.5	69.3	72	99.9	110		
															9.6	2.5	—	—	82.8	100		
															9.6	2.5	34.6	36	85.9	100		
															9.6	2.5	69.3	72	111.9	125		
25	27.0	—	2.5	—	—	79.5	100															
		—	2.5	34.6	36	80.1	100															
		—	2.5	69.3	72	106.2	125															
		9.6	2.5	—	—	89.1	110															
		9.6	2.5	34.6	36	92.1	110															
		9.6	2.5	69.3	72	118.2	125															

See Legend and Notes on page 83.

Electrical data (cont)



50A2,A3,A4,A5 UNITS WITH CONVENIENCE OUTLET (cont)

UNIT SIZE 50A	VOLTAGE 3 PH, 60 Hz	VOLTAGE RANGE		COMPRESSOR								CONDENSER FAN MOTOR		EVAPORATOR FAN MOTOR		POWER EXHAUST	CONVENIENCE OUTLET	OPTIONAL ELECTRIC HEAT		POWER SUPPLY	
		Min	Max	Cir A, No. 1		Cir A, No. 2		Cir B, No. 1		Cir B, No. 2		Qty	FLA	Hp	FLA	FLA (total)	FLA	FLA	kW	MCA	MOCP*
		RLA	LRA	RLA	LRA	RLA	LRA	RLA	LRA	RLA	LRA										
040	208	187	229	28.2	239	28.2	239	28.2	239	28.2	239	4	6.5 (ea)	15	46.2	—	7.0	—	—	203.6	225
																—	7.0	75.1	27	203.6	225
																—	7.0	150.1	54	216.6	250
																23.6	7.0	—	—	227.2	250
																—	7.0	75.1	27	227.2	250
																—	7.0	150.1	54	246.1	250
	230	207	253	28.2	239	28.2	239	28.2	239	28.2	239	4	6.6 (ea)	15	42.0	—	7.0	—	—	198.7	225
																—	7.0	86.6	36	198.7	225
																—	7.0	173.2	72	234.5	250
																23.6	7.0	—	—	222.3	250
																—	7.0	86.6	36	222.3	250
																—	7.0	173.2	72	264.0	300
230	207	253	28.2	239	28.2	239	28.2	239	28.2	239	4	6.6 (ea)	20	54.0	—	7.0	—	—	213.7	250	
															—	7.0	86.6	36	213.7	250	
															—	7.0	173.2	72	249.5	300	
															23.6	7.0	—	—	237.3	250	
															—	7.0	86.6	36	237.3	250	
															—	7.0	173.2	72	279.0	300	
230	207	253	28.2	239	28.2	239	28.2	239	28.2	239	4	6.6 (ea)	25	68.0	—	7.0	—	—	231.2	250	
															—	7.0	86.6	36	231.2	250	
															—	7.0	173.2	72	267.0	300	
															23.6	7.0	—	—	254.8	300	
															—	7.0	86.6	36	254.8	300	
															—	7.0	173.2	72	296.5	350	
040	460	414	508	14.7	130	14.7	130	14.7	130	14.7	130	4	3.3 (ea)	15	21.0	—	3.5	—	—	101.8	110
																—	3.5	43.3	36	101.8	110
																—	3.5	86.6	72	117.2	125
																12.6	3.5	—	—	114.4	125
																—	3.5	43.3	36	114.4	125
																—	3.5	86.6	72	133.0	150
	460	414	508	14.7	130	14.7	130	14.7	130	14.7	130	4	3.3 (ea)	20	27.0	—	3.5	—	—	109.3	125
																—	3.5	43.3	36	109.3	125
																—	3.5	86.6	72	124.7	150
																12.6	3.5	—	—	121.9	125
																—	3.5	43.3	36	121.9	125
																—	3.5	86.6	72	140.5	150
460	414	508	14.7	130	14.7	130	14.7	130	14.7	130	4	3.3 (ea)	25	34.0	—	3.5	—	—	118.0	150	
															—	3.5	43.3	36	118.0	150	
															—	3.5	86.6	72	133.5	150	
															12.6	3.5	—	—	130.6	150	
															—	3.5	43.3	36	130.6	150	
															—	3.5	86.6	72	149.2	175	
040	575	518	632	11.3	93.7	11.3	93.7	11.3	93.7	11.3	93.7	4	2.6 (ea)	15	17.0	—	2.5	—	—	79.4	90
																—	2.5	34.6	36	79.4	90
																—	2.5	69.3	72	93.7	110
																9.6	2.5	—	—	89.0	100
																—	2.5	34.6	36	89.0	100
																—	2.5	69.3	72	105.7	110
	575	518	632	11.3	93.7	11.3	93.7	11.3	93.7	11.3	93.7	4	2.6 (ea)	20	22.0	—	2.5	—	—	85.6	100
																—	2.5	34.6	36	85.6	100
																—	2.5	69.3	72	99.9	110
																9.6	2.5	—	—	95.2	110
																—	2.5	34.6	36	95.2	110
																—	2.5	69.3	72	111.9	125
575	518	632	11.3	93.7	11.3	93.7	11.3	93.7	11.3	93.7	4	2.6 (ea)	25	27.0	—	2.5	—	—	91.9	110	
															—	2.5	34.6	36	91.9	110	
															—	2.5	69.3	72	106.2	125	
															9.6	2.5	—	—	101.5	125	
															—	2.5	34.6	36	101.5	125	
															—	2.5	69.3	72	118.2	125	

See Legend and Notes on page 83.



50A2,A3,A4,A5 UNITS WITH CONVENIENCE OUTLET (cont)

UNIT SIZE 50A	VOLTAGE 3 PH, 60 Hz	VOLTAGE RANGE		COMPRESSOR								CONDENSER FAN MOTOR		EVAPORATOR FAN MOTOR		POWER EXHAUST	CONVENIENCE OUTLET	OPTIONAL ELECTRIC HEAT		POWER SUPPLY	
		Min	Max	Cir A, No. 1		Cir A, No. 2		Cir B, No. 1		Cir B, No. 2		Qty	FLA	Hp	FLA	FLA (total)	FLA	FLA	kW	MCA	MOCP*
		RLA	LRA	RLA	LRA	RLA	LRA	RLA	LRA	RLA	LRA										
050	208	187	229	33.3	239	33.3	239	33.3	239	33.3	239	4	6.5 (ea)	20	59.0	—	7.0	—	—	240.5	250
																—	7.0	75.1	27	240.5	250
																—	7.0	150.1	54	240.5	250
																23.6	7.0	—	—	264.1	300
																—	7.0	75.1	27	264.1	300
																—	7.0	150.1	54	264.1	300
		25	75.0	—	7.0	—	—	259.7	300												
				—	7.0	75.1	27	259.7	300												
				—	7.0	150.1	54	259.7	300												
				23.6	7.0	—	—	283.3	350												
				—	7.0	75.1	27	283.3	350												
				—	7.0	150.1	54	283.3	350												
	30	88.0	—	7.0	—	—	276.2	350													
			—	7.0	75.1	27	276.2	350													
			—	7.0	150.1	54	276.2	350													
			23.6	7.0	—	—	299.8	350													
			—	7.0	75.1	27	299.8	350													
			—	7.0	150.1	54	299.8	350													
	230	207	253	33.3	239	33.3	239	33.3	239	33.3	239	4	6.6 (ea)	20	54.0	—	7.0	—	—	234.1	250
																—	7.0	86.6	36	234.1	250
																—	7.0	173.2	72	249.5	300
																23.6	7.0	—	—	257.7	300
																—	7.0	86.6	36	257.7	300
																—	7.0	173.2	72	279.0	300
25		68.0	—	7.0	—	—	251.6	300													
			—	7.0	86.6	36	251.6	300													
			—	7.0	173.2	72	267.0	300													
			23.6	7.0	—	—	275.2	300													
			—	7.0	86.6	36	275.2	300													
			—	7.0	173.2	72	296.5	350													
30	80.0	—	7.0	—	—	266.6	300														
		—	7.0	86.6	36	266.6	300														
		—	7.0	173.2	72	282.0	350														
		23.6	7.0	—	—	290.2	350														
		—	7.0	86.6	36	290.2	350														
		—	7.0	173.2	72	311.5	350														
460	414	508	17.9	125	17.9	125	17.9	125	17.9	125	4	3.3 (ea)	20	27.0	—	3.5	—	—	122.1	125	
															—	3.5	43.3	36	122.1	125	
															—	3.5	86.6	72	124.7	150	
															12.6	3.5	—	—	134.7	150	
															—	3.5	43.3	36	134.7	150	
															—	3.5	86.6	72	140.5	150	
	25	34.0	—	3.5	—	—	130.8	150													
			—	3.5	43.3	36	130.8	150													
			—	3.5	86.6	72	133.5	150													
			12.6	3.5	—	—	143.4	175													
			—	3.5	43.3	36	143.4	175													
			—	3.5	86.6	72	149.2	175													
30	40.0	—	3.5	—	—	138.3	175														
		—	3.5	43.3	36	138.3	175														
		—	3.5	86.6	72	141.0	175														
		12.6	3.5	—	—	150.9	175														
		—	3.5	43.3	36	150.9	175														
		—	3.5	86.6	72	156.7	175														
575	518	632	12.8	80	12.8	80	12.8	80	12.8	80	4	2.6 (ea)	20	22.0	—	2.5	—	—	91.6	110	
															—	2.5	34.6	36	91.6	110	
															—	2.5	69.3	72	99.9	110	
															9.6	2.5	—	—	101.2	110	
															—	2.5	34.6	36	101.2	110	
															—	2.5	69.3	72	111.9	125	
	25	27.0	—	2.5	—	—	97.9	110													
			—	2.5	34.6	36	97.9	110													
			—	2.5	69.3	72	106.2	125													
			9.6	2.5	—	—	107.5	125													
			—	2.5	34.6	36	107.5	125													
			—	2.5	69.3	72	118.2	125													
30	32.0	—	2.5	—	—	104.1	125														
		—	2.5	34.6	36	104.1	125														
		—	2.5	69.3	72	112.4	125														
		9.6	2.5	—	—	113.7	125														
		—	2.5	34.6	36	113.7	125														
		—	2.5	69.3	72	124.4	150														

See Legend and Notes on page 83.

Electrical data (cont)



50A2,A3,A4,A5 UNITS WITH CONVENIENCE OUTLET (cont)

UNIT SIZE 50A	VOLTAGE 3 PH, 60 Hz	VOLTAGE RANGE		COMPRESSOR								CONDENSER FAN MOTOR		EVAPORATOR FAN MOTOR		POWER EXHAUST	CONVENIENCE OUTLET	OPTIONAL ELECTRIC HEAT		POWER SUPPLY	
				Cir A, No. 1		Cir A, No. 2		Cir B, No. 1		Cir B, No. 2											
		Min	Max	RLA	LRA	RLA	LRA	RLA	LRA	RLA	LRA	Qty	FLA	Hp	FLA	FLA (total)	FLA	FLA	kW	MCA	MOCP*
060 (MCHX)	208	187	229	51.3	300	51.3	300	51.3	300	51.3	300	4	5.5 (ea)	25	75.0	—	7.0	—	—	327.7	400
																—	7.0	112.6	41	327.7	400
																—	7.0	225.2	81	327.7	400
																35.4	7.0	—	—	363.1	400
																—	7.0	112.6	41	363.1	400
																—	7.0	225.2	81	371.7	400
	230	207	253	51.3	300	51.3	300	51.3	300	51.3	300	4	5.8 (ea)	25	68.0	—	7.0	—	—	320.4	350
																—	7.0	129.9	54	320.4	350
																—	7.0	259.8	108	353.6	400
																35.4	7.0	—	—	355.8	400
																—	7.0	129.9	54	355.8	400
																—	7.0	259.8	108	397.8	450
460	414	508	22.4	150	22.4	150	22.4	150	22.4	150	4	2.9 (ea)	25	34.0	—	3.5	—	—	147.2	175	
															—	3.5	65.0	54	147.2	175	
															—	3.5	129.9	108	176.8	200	
															18.9	3.5	—	—	166.1	200	
															—	3.5	65.0	54	166.1	200	
															—	3.5	129.9	108	200.4	225	
575	518	632	19.9	109	19.9	190	19.9	109	19.9	109	4	2.3 (ea)	25	27.0	—	2.5	—	—	125.1	150	
															—	2.5	65.0	54	125.1	150	
															—	2.5	129.9	108	140.8	150	
															14.4	2.5	—	—	139.5	150	
															—	2.5	65.0	54	139.5	150	
															—	2.5	129.9	108	158.8	175	
50A	208	187	229	51.3	300	51.3	300	51.3	300	51.3	300	4	5.5 (ea)	30	88.0	—	7.0	—	—	344.2	400
																—	7.0	112.6	41	344.2	400
																—	7.0	225.2	81	344.2	400
																35.4	7.0	—	—	379.6	450
																—	7.0	112.6	41	379.6	450
																—	7.0	225.2	81	388.2	450
50A	230	207	253	51.3	300	51.3	300	51.3	300	51.3	300	4	5.8 (ea)	30	80.0	—	7.0	—	—	335.4	400
																—	7.0	129.9	54	335.4	400
																—	7.0	259.8	108	368.6	400
																35.4	7.0	—	—	370.8	450
																—	7.0	129.9	54	370.8	450
																—	7.0	259.8	108	412.8	450
50A	460	414	508	22.4	150	22.4	150	22.4	150	22.4	150	4	2.9 (ea)	40	104.0	—	7.0	—	—	365.4	450
																—	7.0	129.9	54	365.4	450
																—	7.0	259.8	108	398.6	500
																35.4	7.0	—	—	400.8	500
																—	7.0	129.9	54	400.8	500
																—	7.0	259.8	108	442.8	500

See Legend and Notes on page 83.

50A2,A3,A4,A5 UNITS WITH CONVENIENCE OUTLET (cont)

UNIT SIZE 50A	VOLTAGE 3 PH, 60 Hz	VOLTAGE RANGE		COMPRESSOR								CONDENSER FAN MOTOR		EVAPORATOR FAN MOTOR		POWER EXHAUST	CONVENIENCE OUTLET	OPTIONAL ELECTRIC HEAT		POWER SUPPLY	
		Min	Max	Cir A, No. 1		Cir A, No. 2		Cir B, No. 1		Cir B, No. 2		Qty	FLA	Hp	FLA	FLA (total)	FLA	FLA	kW	MCA	MOCP*
				RLA	LRA	RLA	LRA	RLA	LRA	RLA	LRA										
060 (RTPF)	208	187	229	51.3	300	51.3	300	51.3	300	51.3	300	6	6.5 (ea)	25	74.8	—	7.0	—	—	344.7	400
																—	7.0	112.6	41	344.7	400
																—	7.0	225.2	81	344.7	400
																35.4	7.0	—	—	380.1	450
																—	7.0	112.6	41	380.1	450
																—	7.0	225.2	81	380.7	450
		—	7.0	—	—	361.2	400														
		—	7.0	112.6	41	361.2	400														
		—	7.0	225.2	81	361.2	400														
		35.4	7.0	—	—	396.6	450														
		—	7.0	112.6	41	396.6	450														
		—	7.0	225.2	81	396.6	450														
	—	7.0	—	—	393.7	500															
	—	7.0	112.6	41	393.7	500															
	—	7.0	225.2	81	393.7	500															
	35.4	7.0	—	—	429.1	500															
	—	7.0	112.6	41	429.1	500															
	—	7.0	225.2	81	429.1	500															
	230	207	253	51.3	300	51.3	300	51.3	300	51.3	300	6	6.6 (ea)	25	68.0	—	7.0	—	—	336.8	400
																—	7.0	129.9	54	336.8	400
																—	7.0	259.8	108	353.6	400
																35.4	7.0	—	—	372.2	400
																—	7.0	129.9	54	372.2	400
																—	7.0	259.8	108	397.8	450
—		7.0	—	—	351.8	400															
—		7.0	129.9	54	351.8	400															
—		7.0	259.8	108	368.6	400															
35.4		7.0	—	—	387.2	450															
—		7.0	129.9	54	387.2	450															
—		7.0	259.8	108	412.8	450															
—	7.0	—	—	381.8	450																
—	7.0	129.9	54	381.8	450																
—	7.0	259.8	108	398.6	500																
35.4	7.0	—	—	417.2	500																
—	7.0	129.9	54	417.2	500																
—	7.0	259.8	108	442.8	500																
460	414	508	22.4	150	22.4	150	22.4	150	22.4	150	6	3.3 (ea)	25	34.0	—	3.5	—	—	155.4	175	
															—	3.5	65.0	54	155.4	175	
															—	3.5	129.9	108	176.8	200	
															18.9	3.5	—	—	174.3	200	
															—	3.5	65.0	54	174.3	200	
															—	3.5	129.9	108	200.4	225	
	—	3.5	—	—	162.9	200															
	—	3.5	65.0	54	162.9	200															
	—	3.5	129.9	108	184.3	200															
	18.9	3.5	—	—	181.8	200															
	—	3.5	65.0	54	181.8	200															
	—	3.5	129.9	108	207.9	225															
—	3.5	—	—	177.9	225																
—	3.5	65.0	54	177.9	225																
—	3.5	129.9	108	199.3	250																
18.9	3.5	—	—	196.8	225																
—	3.5	65.0	54	196.8	225																
—	3.5	129.9	108	222.9	250																
575	518	632	19.9	109	19.9	190	19.9	109	19.9	109	6	2.6 (ea)	25	27.0	—	2.5	—	—	131.5	150	
															—	2.5	52.0	54	131.5	150	
															—	2.5	103.9	108	140.8	150	
															14.4	2.5	—	—	145.9	150	
															—	2.5	52.0	54	145.9	150	
															—	2.5	103.9	108	158.8	175	
	—	2.5	—	—	137.7	150															
	—	2.5	52.0	54	137.7	150															
	—	2.5	103.9	108	147.0	175															
	14.4	2.5	—	—	152.1	175															
	—	2.5	52.0	54	152.1	175															
	—	2.5	103.9	108	165.0	175															
—	2.5	—	—	149.0	175																
—	2.5	52.0	54	149.0	175																
—	2.5	103.9	108	158.3	175																
14.4	2.5	—	—	163.4	200																
—	2.5	52.0	54	163.4	200																
—	2.5	103.9	108	176.3	200																

See Legend and Notes on page 83.

Control components

The 48/50A Series rooftops use the *ComfortLink* control system that has been developed for use in Carrier Commercial equipment. The control system monitors all operating conditions in the rooftop unit, as well as controlling the compressors, economizers, fans, heat, and other devices. It also has the capability of communicating with the Carrier Comfort Network® devices using the CCN protocol and other popular protocols including BACnet, MODBUS, LonWorks, etc.

The system uses a microprocessor and a series of boards, each with inputs and outputs. A local network communications bus (LEN) ties all the boards together into a system and enables the boards to communicate.

For the 48/50A Series, the control consists of the following key components:

Main base board (MBB) — The MBB is the center of the *ComfortLink* control system. It contains the major portion of the operating software and controls the operation of the unit. The MBB continuously monitors inputs and outputs as well as data from the LEN and CCN communications channels. The MBB also controls 11 output relays. A complete list of the MBB and system I/O are contained in the table on page 109. The board is located in the main control box.

Economizer control board (ECB1) — The ECB1 controls the economizer actuator. The ECB1 controls the economizer motor using a digital communications signal that also provides operation and diagnostic data on the economizer motor. The ECB1 also controls the operation of the power exhaust motors and provides up to 6 stages of digitally sequenced power exhaust. Exhaust sequencing can be based on either the economizer motor position or the building pressure. On the A Series unit, the ECB1 board is located in an auxiliary box located at the end of the unit near the economizer motor. The board also contains a second LEN port that can be used with the handheld Navigator™ display.

Supply and building pressure control board (ECB2 or RXB) — The board, which is the same hardware as the ECB1, is used to control the supply fan inverter on the VAV units. It sends a 4 to 20 mA signal to the inverter based on a supply duct pressure sensor connected to the board. The board also accepts a signal from another pressure sensor that monitors building pressure and controls the operation of the optional modulating power exhaust system.

On units equipped with the variable capacity compressor and/or Humidi-MiZer system, this board is called the RXB. The RXB performs the same functions as the ECB2 and has additional inputs and outputs to control the variable capacity compressor as well as the Humidi-MiZer adaptive dehumidification system. The ECB2/RXB is located in the auxiliary control box.

Staged gas heat board (SCB) — When the optional staged gas heat is used, the SCB board will be installed and will control the operation of the gas valves. It also provides additional sensors for monitoring the supply air temperature. This board is located in the gas heat section of the unit.

Integrated gas controller (IGC) — One IGC is provided with each bank of gas heat exchangers. It controls the direct spark ignition system and monitors the rollout switch, limit switches, and induced-draft motor Hall Effect sensor. It is equipped with an LED for diagnostics.

Controls expansion module (CEM) — The optional expansion module is used to provide inputs for demand limiting, remote set point, and other optional inputs. It is located in the main control box.

Compressor protection Cycle-LOC™ board (CS) — This board monitors the status of the compressor by sensing the current flow to the compressors; it then provides digital status signal to the MBB.

Expansion valve control board (EXV) — The optional EXV board controls both the condenser and bypass modulation valves of the humidifier. This board also receives inputs to sense the evaporative discharge temperature if the unit has the humidifier option. This board is located in the auxiliary control box.

Low ambient outdoor fan control board (SCB2) — The optional low ambient board controls the Motormaster® V inverter fan speed control of the outdoor fan(s). This board is located in the auxiliary control box.

Scrolling marquee display — This device is the keypad interface used to access the control information, read sensor values, test the unit, and monitor alarm status. The marquee display is a 4-key, 4-character, 16-segment LED (light-emitting diode) display. The display is very easy to operate using 4 buttons and a group of 11 LEDs that indicate the following menu structures:

- Run Status
- Service Test
- Temperatures
- Pressures
- Set Points
- Inputs
- Outputs
- Configuration
- Timeclock
- Operating Modes
- Alarms

Through the display, inputs and outputs can be checked for their value or status. Because the unit is equipped with suction pressure transducers and discharge saturation temperature sensors, it can also display pressures typically obtained from gages. The control includes a full alarm history which can be accessed from the display. Through the display, a built-in test routine can be used at start-up commission and during maintenance inspections to help diagnose operational problems with the unit.

MAIN BASE BOARD (MBB) INPUTS AND OUTPUTS

POINT NAME	POINT DESCRIPTION	I/O POINT NAME	PLUG AND PIN REFERENCE	SIGNAL PIN(S)	PORT STATE
INPUTS					
GASFAN	YAC Indoor Fan relay (fan request from YAC)	DI1	J6, 3-4	4	0 = 24vac, 1= 0vac
FSD	Fire Shutdown switch input	DI2	J6, 5-6	6	0 = 24vac, 1= 0vac
G	Thermostat 'G' input/Remote Occupied	DI3	J7, 1-2	2	0 = 24vac, 1= 0vac
W2	Thermostat 'W2' input	DI4	J7, 3-4	4	0 = 24vac, 1= 0vac
W1	Thermostat 'W1' input	DI5	J7, 5-6	6	0 = 24vac, 1= 0vac
Y2	Thermostat 'Y2' input	DI6	J7, 7-8	8	0 = 24vac, 1= 0vac
Y1	Thermostat 'Y1' input	DI7	J7, 9-10	10	0 = 24vac, 1= 0vac
CSB_A1	Compressor A1 current sensor	DIG1	J9, 10-12	10=5v, 11=Vin, 12=GND	0 = 5vdc, 1 = 0vdc
CSB_A2	Compressor A2 current sensor	DIG2	J9, 7-9	7=5v, 8=Vin, 9=GND	0 = 5vdc, 1 = 0vdc
CSB_B1	Compressor B1 current sensor	DIG3	J9, 4-6	4=5v, 5=Vin, 6 =GND	0 = 5vdc, 1 = 0vdc
CSB_B2	Compressor B2 current sensor	DIG4	J9, 1-3	1=5v, 2=Vin, 3=GND	0 = 5vdc, 1 = 0vdc
DP_A/SCTA	Circuit A saturated condensing pressure/temp	AN1	J8, 21-23	21=5v, 22=Vin, 23=GND (thermistor 21-22)	(0-5vdc, thermistor, ohms)
DP_B/SCTB	Circuit B saturated condensing pressure/temp	AN2	J8, 24-26	24=5v, 25=Vin, 26=GND (thermistor 24-25)	(0-5vdc, thermistor, ohms)
SP_A/SSTA	Circuit A saturated suction pressure/temp	AN3	J8, 15-17	15=5v, 16=Vin, 17=GND (thermistor 15-16)	(0-5vdc, thermistor, ohms)
SP_B/SSTB	Circuit B saturated suction pressure/temp	AN4	J8, 18-20	18=5v, 19=Vin, 20=GND (thermistor 18-20)	(0-5vdc, thermistor, ohms)
RAT	Return air temperature	AN5	J8, 9-10	9	(thermistor, ohms)
SA_TEMP	Supply air temperature	AN6	J8, 11-12	11	(thermistor, ohms)
OAT	Outdoor air temperature	AN7	J8, 13-14	13	(thermistor, ohms)
SPT	Space temperature (T55/56)	AN8	J8, 1-2	1	(thermistor, ohms)
SPTO	Space temperature offset (T56)	AN9	J8, 3-4	3	(thermistor, ohms)
IAQ/IAQMINOV	IAQ analog input	AN10	J8, 5-6	5	(thermistor, ohms)
FLTS	Filter Status	AN11	J8, 7-8	7	(thermistor, ohms)
OUTPUTS					
CMPB2	Compressor B2	RLY 1	J10, 20-21	20 = RLY1A (=RLY2A), 21 = RLY1B	1 = Closes RLY1A/RLY1B
CMPB1	Compressor B1	RLY 2	J10, 22-23	22 = RLY2A (=RLY1A), 23 = RLY2B	1 = Closes RLY2A/RLY2B
CMPA2	Compressor A2	RLY 3	J10, 24-25	24 = RLY3A (=RLY4A), 25 = RLY3B	1 = Closes RLY3A/RLY3B
CMPA1	Compressor A1	RLY 4	J10, 26-27	26 = RLY4A (=RLY3A), 27 = RLY4B	1 = Closes RLY4A/RLY4B
CONDFANB	Condenser fan B	RLY 5	J10, 10-11	10 = RLY5A (=RLY6A), 11 = RLY5B	1 = Closes RLY5A/RLY5B
CONDFANA	Condenser fan A	RLY 6	J10, 12-13	12 = RLY6A (=RLY5A), 13 = RLY6B	1 = Closes RLY6A/RLY6B
HS2	Heat stage 2	RLY7	J10, 14-16	14 = 15 = RLY7A, 16 = RLY7B	1 = Closes RLY7A/RLY7B
HS1	Heat stage 1	RLY 8	J10, 17-19	17 = 18 = RLY8A, 19 = RLY8B	1 = Closes RLY8A/RLY8B
HIR	Heat interlock relay	RLY 9	J10, 4-6	4 = 5 = RLY9A, 6 = RLY9B	1 = Closes RLY9A/RLY9B
SF	Supply fan	RLY 10	J10, 7-9	7 = 8 = RLY10A, 9 = RLY10B	1 = Closes RLY10A/RLY10B
ALRM	Alarm output relay	RLY 11	J10, 1-3	1 = 2 = RLY11A, 3 = RLY11B	1 = Closes RLY11A/RLY11B

LEGEND

IAQ — Indoor-Air Quality
YAC — Gas Heat Unit

CONTROLS EXPANSION MODULE (CEM) INPUTS

POINT NAME	POINT DESCRIPTION	I/O POINT NAME	PLUG AND PIN REFERENCE	SIGNAL PIN(S)	PORT STATE
INPUTS					
SFS	Supply Fan Status switch	DI 1	J7, 1-2	2	0 = 24vac, 1= 0vac
DMD_SW1	Demand Limit - SW1	DI 2	J7, 3-4	4	0 = 24vac, 1= 0vac
DMD_SW2/DHDISCIN	Demand Limit - SW2 / Dehumidification Switch Input	DI 3	J7, 5-6	6	0 = 24vac, 1= 0vac
PRES	Pressurization	DI 4	J7, 7-8	8	0 = 24vac, 1= 0vac
EVAC	Evacuation	DI 5	J7, 9-10	10	0 = 24vac, 1= 0vac
PURG	Purge	DI 6	J7, 11-12	12	0 = 24vac, 1= 0vac
IAQIN	Indoor Air Quality Switch	DI 7	J7, 13-14	14	0 = 24vac, 1= 0vac
		AN7	J6, 1-3	2 (1 = loop power)	(0-20mA input)
DMDLMTMA	4-20mA Demand Limit	AN8	J6, 4-6	5 (4 = loop power)	(0-20mA input)
EDTRESMA	4-20mA Evaporator Discharge SP Reset	AN9	J6, 7-9	8 (7 = loop power)	(0-20mA input)
OAQ	Outside Air CO ₂ Sensor	AN10	J6, 10-12	11 (10 = loop power)	(0-20mA input)
SPRESET	SP Reset milliamps	AN10	J6, 10-12	11 (10 = loop power)	(0-20mA input)
CEM_10K1/CEM_4201	CEM AN1 10k temp J5,1-2/CEM AN1 4-20 ma J5,1-2	AN1	J5, 1-2	1	(thermistor, ohms)
CEM_10K2/CEM_4202	CEM AN2 10k temp J5,3-4/CEM AN2 4-20 ma J5,3-4	AN2	J5, 3-4	3	(thermistor, ohms)
CEM_10K3/CEM_4203	CEM AN3 10k temp J5,5-6/CEM AN3 4-20 ma J5,5-6	AN3	J5, 5-6	5	(thermistor, ohms)
CEM_10K4/CEM_4204	CEM AN4 10k temp J5,7-8/CEM AN4 4-20 ma J5,7-8	AN4	J5, 7-8	7	(thermistor, ohms)
		AN5	J5, 9-10	9	(thermistor, ohms)
		AN6	J5, 11-12	11	(thermistor, ohms)

Controls (cont)



ECONOMIZER CONTROL BOARD (ECB1) INPUTS AND OUTPUTS

POINT NAME	POINT DESCRIPTION	I/O POINT NAME	PLUG AND PIN REFERENCE	SIGNAL PIN(S)	PORT STATE
INPUTS					
RMTIN	Remote occupancy	DI1	J4, 1-2	2	24VAC = 1, 0VAC = 0
ECONENBL, ECOORIDE	Economizer enable	DI2	J4, 3-4	4	24VAC = 1, 0VAC = 0
RARH	Return air relative humidity	AN1	J5, 1-3	1=24VDC, 2=0-20mA in, 3=GND	0-20mA
OARH	Outdoor air relative humidity	AN2	J5, 4-6	4=24VDC, 5=0-20mA in, 6=GND	0-20mA
OUTPUTS					
ECB1_AO1	ECB1, analog output 1	AO1	J9, 1-2	1=0-20mA, 2=GND	0-20mA OUT
ECONOCMD	Economizer actuator (digital control)	PP/MP	J7, 1-3	1=PP/MP Data, 2=24VAC, 3=GND	Belimo PP/MP Protocol
PE_A	Power Exhaust stage A	RLY1	J8, 1-3	1 = 2 = RLY1A, 3 = RLY1B	1 = Closes RLY1A/RLY1B
PE_B	Power Exhaust stage B	RLY 2	J8, 4-6	4 =5 = RLY2A, 6 = RLY2B	1 = Closes RLY2A/RLY2B
PE_C	Power Exhaust stage C	RLY 3	J8, 7-9	7 = 8 = RLY3A, 9 = RLY3B	1 = Closes RLY3A/RLY3B
ECON_PWR	Economizer Power	RLY 6	J8, 16-18	16 = 17 = RLY6A, 18 = RLY6B	1 = Closes RLY6A/RLY6B

RXB CONTROL BOARD (ECB2) INPUTS AND OUTPUTS

POINT NAME	POINT DESCRIPTION	I/O POINT NAME	PLUG AND PIN REFERENCE	SIGNAL PIN(S)	PORT STATE
INPUTS					
		DI1	J4, 1-2	2=Vin, 1=24VAC	24VAC = 1, 0VAC = 0
		DI2	J4, 3-4	4=Vin, 3=24vac	24VAC = 1, 0VAC = 0
		DI3	J4, 5-6	6=Vin, 5=24vac	
		DI4	J4, 7-8	8=Vin, 7=24vac	
		DI5	J4, 9-10	10=Vin, 9=24vac	
		DI6	J4, 11-12	12=Vin, 11=24vac	
BP	Building static pressure	AN1	J5, 1-3	1=24VDC, 2=0-20mA in, 3=GND	0-20mA
SP	Supply Duct static pressure	AN2	J5, 4-6	4=24VDC, 5=0-20mA in, 6=GND	0-20mA
CCT	Air Temp Lvg Evap Coil	AN3	J6, 1-2	1=Vin, 2=GND	(thermistor, ohms)
DSDT	DS Discharge Temperature	AN4	J6, 3-4	3=Vin, 4=GND	(thermistor, ohms)
		AN5	J6, 5-6	5=Vin, 6=GND	(thermistor, ohms)
		AN6	J6, 7-8	7=Vin, 8=GND	(thermistor, ohms)
OUTPUTS					
SFAN_VFD	Supply Fan Inverter speed	AO1	J9, 1-2	1=0-20mA, 2=GND	0-20mA OUT
CMPDSCAP	Digital Scroll Solenoid	PP/MP	J7, 1-3	1=PP/MP Data, 2=24VAC, 3=GND	Belimo PP/MP Protocol
		RLY1	J8, 1-3	1 = 2 = RLY1A, 3 = RLY1B	1 = Closes RLY1A / RLY1B
		RLY2	J8, 4-6	4 = 5 = RLY2A, 6 = RLY2B	1 = Closes RLY2A / RLY2B
HUM3WVAL	Humidimizer 3 Way Valve	RLY3	J8, 7-9	7 = 8 = RLY3A, 9 = RLY3B	1 = Closes RLY3A / RLY3B
		RLY4	J8, 10-12	10 = 11 = RLY4A, 12 = RLY4B	1 = Closes RLY4A / RLY4B
		RLY5	J8, 13-15	13 = 14 = RLY5A, 15 = RLY5B	1 = Closes RLY5A / RLY5B
MLV	Minimum load valve	RLY 6	J8, 16-18	16 = 17 = RLY6A, 18 = RLY6B	1 = Closes RLY6A / RLY6B

NOTE: RXB is required for Digital Scroll or Humidi-MiZer option.

STAGED GAS HEAT BOARD (SCB) INPUTS AND OUTPUTS

POINT NAME	POINT DESCRIPTION	I/O POINT NAME	PLUG AND PIN REFERENCE	SIGNAL PIN(S)	PORT STATE
INPUTS					
		AN1	J5, 1-3	1=5v, 2=Vin, 3=GND (thermistor 1-2)	(0-5VDC, thermistor, ohms)
		AN2	J5, 4-6	4=5v, 5=Vin, 6=GND (thermistor 4-5)	(0-5VDC, thermistor, ohms)
LAT1SGAS	Leaving air temperature 1	AN3	J5, 7-9	7=5v, 8=Vin, 9=GND (thermistor 7-8)	(0-5VDC, thermistor, ohms)
LAT2SGAS	Leaving air temperature 2	AN4	J5, 10-12	10=5v, 11=Vin, 12=GND (thermistor 10-11)	(0-5VDC, thermistor, ohms)
LAT3SGAS	Leaving air temperature 3	AN5	J5, 13-15	13=5v, 14=Vin, 15=GND (thermistor 13-14)	(0-5VDC, thermistor, ohms)
		AN6	J6, 1-3	1=5v, 2=Vin, 3=GND (thermistor 1-2)	(0-5VDC, thermistor, ohms)
		AN7	J6, 4-6	4=5v, 5=Vin, 6=GND (thermistor 4-5)	(0-5VDC, thermistor, ohms)
		AN8	J6, 7-9	7=5v, 8=Vin, 9=GND (thermistor 7-8)	(0-5VDC, thermistor, ohms)
		AN9	J7, 1-2	1	(thermistor, ohms)
		AN10	J7, 3-4	3	(thermistor, ohms)
OUTPUTS					
		AO1	J8, 1-2	1=0-20mA, 2=GND	0-20mA OUT
		AO2	J8, 3-4	3=0-20mA, 4=GND	0-20mA OUT
HS3	Heat Stage 3	RLY1	J9, 1-3	1 = 2 = RLY1A, 3 = RLY1B	1 = Closes RLY1A/RLY1B
HS4	Heat Stage 4	RLY 2	J9, 4-6	4 =5 = RLY2A, 6 = RLY2B	1 = Closes RLY2A/RLY2B
HS5	Heat Stage 5	RLY 3	J9, 7-9	7 = 8 = RLY3A, 9 = RLY3B	1 = Closes RLY3A/RLY3B
HS6	Heat Stage 6	RLY 4	J9, 10-12	10 = 11 = RLY4A, 12 = RLY4B	1 = Closes RLY4A/RLY4B
		RLY 5	J9, 13-15	13 = 14 = RLY5A, 15 = RLY5B	1 = Closes RLY5A/RLY5B

LOW AMBIENT CONTROL BOARD (SCB2) INPUTS AND OUTPUTS

POINT NAME	POINT DESCRIPTION	I/O POINT NAME	PLUG AND PIN REFERENCE	SIGNAL PIN(S)	PORT STATE
INPUTS					
		AN1	J5, 1-3	1=5v, 2=Vin, 3=GND (thermistor 1-2)	(0-5 vdc, thermistor, ohms)
		AN2	J5, 4-6	4=5v, 5=Vin, 6=GND (thermistor 4-5)	(0-5 vdc, thermistor, ohms)
		AN3	J5, 7-9	7=5v, 8=Vin, 9=GND (thermistor 7-8)	(0-5 vdc, thermistor, ohms)
		AN4	J5, 10-12	10=5v, 11=Vin, 12=GND (thermistor 10-11)	(0-5 vdc, thermistor, ohms)
		AN5	J5, 13-15	13=5v, 14=Vin, 15=GND (thermistor 13-14)	(0-5 vdc, thermistor, ohms)
		AN6	J6, 1-3	1=5v, 2=Vin, 3=GND (thermistor 1-2)	(0-5 vdc, thermistor, ohms)
		AN7	J6, 4-6	4=5v, 5=Vin, 6=GND (thermistor 4-5)	(0-5 vdc, thermistor, ohms)
		AN8	J6, 7-9	7=5v, 8=Vin, 9=GND (thermistor 7-8)	(0-5 vdc, thermistor, ohms)
		AN9	J7, 1-2	1	(thermistor, ohms)
		AN10	J7, 3-4	3	(thermistor, ohms)
OUTPUTS					
MM_A_VFD	Motor Master VFD A	AO1	J8, 1-2	1=0-20 mA, 2=GND	0-20 mA OUT
MM_B_VFD	Motor Master VFD B	AO2	J8, 3-4	3=0-20 mA, 4=GND	0-20 mA OUT
MM_A_RUN	Motor Master A RunEnable	RLY1	J9, 1-3	1 = 2 = RLY1A, 3 = RLY1B	1 = Closes RLY1A/RLY1B
MM_B_RUN	Motor Master B RunEnable	RLY2	J9, 4-6	4 =5 = RLY2A, 6 = RLY2B	1 = Closes RLY2A/RLY2B
		RLY3	J9, 7-9	7 = 8 = RLY3A, 9 = RLY3B	1 = Closes RLY3A/RLY3B
		RLY4	J9, 10-12	10 = 11 = RLY4A, 12 = RLY4B	1 = Closes RLY4A/RLY4B
		RLY5	J9, 13-15	13 = 14 = RLY5A, 15 = RLY5B	1 = Closes RLY5A/RLY5B

Controls (cont)



HUMIDI-MIZER CONTROL BOARD (EXV) INPUTS AND OUTPUTS

POINT NAME	POINT DESCRIPTION	I/O POINT NAME	PLUG AND PIN REFERENCE	SIGNAL PIN(S)	PORT STATE	
INPUTS						
CCT	Air Temp Lvg Evap Coil	AN1	J5, 5-6	5=Vin, 6=GND	(Thermistor, ohms)	
		AN2	J5, 7-8	7=Vin, 8 =GND	(Thermistor, ohms)	
		AN3	J5, 9-10	9=Vin, 10=GND	(Thermistor, ohms)	
		AN4	J5, 11-12	11=Vin, 12=GND	(Thermistor, ohms)	
		AN5	J5, 1-2	1=Vin, 2=GND	0-20mA INPUT	
		AN6	J5, 3-4	3=Vin, 4=GND	0-20mA INPUT	
OUTPUTS						
COND_EXV	Condenser EXV Position	OUTA				
		Coil1A	J6,1	1	HI Z when P5.7 and P5.6 = 0 +12 vdc when P5.7 = 1 and P5.6 = 0 0 vdc when P5.7 = 0 and P5.6 = 1 PROHIBITED when P5.7 = 1 and P5.6 = 1	
	Coil2A	J6,2	2	HI Z when P5.5 and P5.4 = 0 +12 vdc when P5.5 = 1 and P5.4 = 0 0 vdc when P5.5 = 0 and P5.4 = 1 PROHIBITED when P5.5 = 1 and P5.4 = 1		
	12VDC	J6, 3	3	Power Output		
	Coil3A	J6,4	4	HI Z when P5.3 and P5.2 = 0 +12 vdc when P5.3 = 1 and P5.2 = 0 0 vdc when P5.3 = 0 and P5.2 = 1 PROHIBITED when P5.3 = 1 and P5.2 = 1		
	Coil4A	J6,5	5	HI Z when P5.1 and P5.0 = 0 +12 vdc when P5.1 = 1 and P5.0 = 0 0 vdc when P5.1 = 0 and P5.0 = 1 PROHIBITED when P5.1 = 1 and P5.0 = 1		
	Bypass EXV Position	OUTB				
		Coil1B	J7,1	1	HI Z when P8.7 and P8.6 = 0 +12 vdc when P8.7 = 1 and P8.6 = 0 0 vdc when P8.7 = 0 and P8.6 = 1 PROHIBITED when P8.7 = 1 and P8.6 = 1	
		Coil2B	J7,2	2	HI Z when P8.5 and P8.4 = 0 +12 vdc when P8.5 = 1 and P8.4 = 0 PROHIBITED when P8.5 = 1 and P8.4 = 1	
		12VDC	J7,3	3	Power Output	
Coil3B		J7,4	4	HI Z when P8.3 and P8.2 = 0 +12 vdc when P8.3 = 1 and P8.2 = 0 0 vdc when P8.3 = 0 and P8.2 = 1 PROHIBITED when P8.3 = 1 and P8.2 = 1		
Coil4B	J7,5	5	HI Z when P8.1 and P8.0 = 0 +12 vdc when P8.1 = 1 and P8.0 = 0 0 vdc when P8.1 = 0 and P8.0 = 1 PROHIBITED when P8.1 = 1 and P8.0 = 1			

INPUT/OUTPUT CHANNEL DESIGNATIONS — FIELD CONNECTION TERMINAL STRIPS

TERMINAL BOARD	TERMINAL NO.	DESCRIPTION	TYPE
TB-1 - POWER CONNECTION OR DISCONNECT (in Main Control Box)			
TB1	11	L1 power supply	208-230/460/575/380/-3-60
	12	L2 power supply	208-230/460/575/380/-3-60
	13	L3 power supply	208-230/460/575/380/-3-60
TB-2 - GROUND (in Main Control Box)			
TB2	1	Neutral Power	
TB-3 - CCN COMMUNICATIONS (HY84HA096) (in Main Control Box)			
TB3	1	LEN +	5 VDC, logic
	2	LEN C	5 VDC, logic
	3	LEN -	5 VDC, logic
	4	24 VAC	24 VAC
	5	CCN +	5 VDC, logic
	6	CCN C	5 VDC, logic
	7	CCN -	5 VDC, logic
	8	Grd	ground
TB-4 - THEROMSTAT CONNECTIONS (HY84HA090) (in Main Control Box)			
TB4	1	Thermostat R	24 VAC Power
	2	Thermostat Y1	24 VAC Input
	3	Thermostat Y2	24 VAC Input
	4	Thermostat W1	24 VAC Input
	5	Thermostat W2	24 VAC Input
	6	Thermostat G	24 VAC Input
	7	Thermostat C	24 VAC Common
	8	Thermostat X (Alarm Contact)	24 VAC Output
TB-5 - FIELD CONNECTIONS (HY84HA101) (in Main Control Box)			
TB5	1	VAV Heater Interlock Relay, Ground	Dry Contact, Max 1 Amp
	2	VAV Heater Interlock Relay, 24 VAC	Dry Contact, Max 1 Amp
	3	T55/T56 10 K Thermistor	Thermistor Input
	4	T55/T56 10 K Thermistor	Thermistor Input
	5	T56 Set Point Adjustment (100,000 ohm)	Thermistor Input
	6	Indoor Air IAQ Remote Sensor/Remote Pot/Remote 4-20 mA	4-20 mA, ext. powered w/res or 0-5 VDC, +
	7	Indoor Air IAQ Remote Sensor/Remote Pot/Remote 4-20 mA	4-20 mA, ext. powered w/res or 0-5 VDC, -
	8	Smoke Detector Remote Alarm	external contacts
	9	Smoke Detector Remote Alarm	external contacts
	10	Fire Shutdown	24 VAC Power
	11	Fire Shutdown	24 VAC Input
	12	Fire Control*	24 VAC Power
	13	Fire Pressurization*	24 VAC Input
	14	Fire Evacuation*	24 VAC Input
	15	Fire Smoke Purge*	24 VAC Input
	16	Not Used	—
TB-6 - FIELD CONNECTIONS (HY84HA101) (in Main Control Box)			
TB6	1	Remote Occupied/Economizer Enable 24 VAC	24 VAC Power
	2	Remote Economizer Contact	24 VAC Input
	3	Remote Occupied Contact	24 VAC Input
	4	Demand Limit Contacts Common*	24 VAC Power
	5	Demand Limit SW1*	24 VAC Input
	6	Demand Limit SW2 / Dehumidification Switch*	24 VAC Input
	7	Demand Limit 4-20 mA*	externally powered 4-20 mA
	8	Demand Limit 4-20 mA*	externally powered 4-20 mA
	9	Remote Supply Air Setpoint 4-20 mA*	externally powered 4-20 mA
	10	Remote Supply Air Setpoint 4-20 mA*	externally powered 4-20 mA
	11	Outdoor Air IAQ 4-20 mA*	externally powered 4-20 mA
	12	Outdoor Air IAQ 4-20 mA*	externally powered 4-20 mA
	13	IAQ Remote Switch*	24 VAC Power
	14	IAQ Remote Switch*	24 VAC Input
	15	Supply Fan Status Switch*	24 VAC Power
	16	Supply Fan Status Switch*	24 VAC Input
TB-7 - ELECTRIC HEAT POWER BLOCK (in Electric Heat section)			
TB7	1	L1 Power Supply	208-230/460/575/380/-3-60, 400-3-50
	2	L2 Power Supply	208-230/460/575/380/-3-60, 400-3-50
	3	L3 Power Supply	208-230/460/575/380/-3-60, 400-3-50

* Requires optional Controls Expansion Module (CEM).

Controls (cont)



Cooling control options

When mechanical cooling is required, the A Series *ComfortLink* controls have the capability to control the staging of the compressors in several different ways:

- 3 compressor stages on 020-027 units.
- 4 compressor stages on 030-060 units.
- Optional variable capacity scroll compressor.
- Optional minimum load hot gas bypass valve (MLV)

The control also integrates the use of an economizer with the use of mechanical cooling to allow for the greatest use of free cooling. When both mechanical cooling and the economizer are being used, the control will use the economizer to provide better temperature control and limit the cycling of the compressors. The control also ensures safety limits are not exceeded and the compressors are reliably operated.

The A Series *ComfortLink* controls offer two basic control approaches to mechanical cooling:

- constant volume/staged air volume
- VAV

Both approaches utilize multiple stages of cooling. In addition, the A Series *ComfortLink* controls offer the ability to run multiple stages of cooling in constant volume/staged air volume operation by controlling the unit to either a low or high cool supply air set point based on either a space temperature sensor or 2-stage thermostat input.

CONTROL TYPE			COOLING CONTROL METHOD
Unit	Application	Demand Source	
A3,A5	VAV	RAT or SPT	VAV Supply Air Temperature (SAT) Control
A2,A4	CV/SAV	SPT or T-STAT	Multiple Adaptive Demand

Control type — The control type determines the selection of the type of cooling control as well as the technique for selecting a cooling mode. The control types are:

VAV-RAT and VAV-SPT — Both of these configurations refer to standard VAV operation. If the control is occupied, the supply fan is run continuously and return-air temperature will be used in the determination of the cooling mode. VAV-SPT differs from VAV-RAT only in that during the unoccupied period, space temperature will be used instead of return-air temperature to start the fan for ten minutes before the return-air temperature is allowed to call out any mode.

CV/SAV TSTAT-Multiple Stage — This configuration will force the control to monitor the thermostat inputs (Y1, Y2) to make a determination of mode. Unlike traditional 2-stage thermostat control, the unit is allowed to use multiple stages of cooling control and perform VAV-style capacity control.

CV/SAV SPT-Multiple Stage — This configuration will force the control to monitor a space temperature sensor to make a determination of mode. The unit is allowed to use multiple stages of cooling control and perform VAV-style capacity control.

Cooling control method — Two different cooling control methods are used to step through the available stages of capacity. Depending on the unit size, cooling control method, and presence of an MLV, this may range from 2 up to 5 stages of capacity control. These methods are:

VAV Supply Air Temperature (SAT) Control — The capacity of the economizer and compressors are controlled based on the evaporator air discharge temperature and supply air temperature set point. This control method uses an adaptive PID (proportional, integral, derivative) algorithm (referred to as SumZ) to calculate the estimated change in supply-air temperature before engaging or disengaging the next stage of cooling. The algorithm compensates for varying conditions, including changing flow rates across the evaporator coil, to provide better overall control of compressor staging.

Multiple Adaptive Demand — This control method will base the capacity of the economizer and compressors on the evaporator air discharge temperature and one of two supply air temperature set points. The control will be able to call out a LOW COOL or a HIGH COOL mode and maintain a low or high cool supply air set point. The unit will either use the input from a conventional thermostat to turn the Y1, Y2 signals into a high and low demand signal, or with a space temperature sensor use a differential from set point to determine the mode. Once the mode has been established, the control uses the same algorithm as with VAV control.

Integrated economizer — For each of the above modes of operation, all mechanical cooling will first be delayed while the unit attempts to use the economizer for free cooling. Once the economizer is at full capacity, the control will then supplement the free cooling with as much mechanical cooling as required. To prevent any rapid changes in cooling, the control will also use the economizer to trim the cooling supplied.

Heating control options

When heating is required, the A Series units can be provided with 2-stage electric heat, 2-stage gas heat, or multiple-stage gas heat. Depending on unit size and heating capacity, the multiple-stage option may have between 5 and 11 stages of heating capacity control. The A Series *ComfortLink* controls have the capability to control the heating capacity based on input from a 2-stage mechanical thermostat, a space temperature sensor, or on VAV units by the return air temperature sensor. With CV/SAV units the heating mode (off, low or high) will be enabled based on W1 and W2 thermostat inputs, or when using a space temperature sensor the differential from heating set point will be used. Heating with VAV units will be enabled based on the return-air temperature or the space temperature, but once enabled, control will be based on the return-air temperature. Variable air volume terminals will be commanded open to the heating cfm through linkage or the heat interlock relay.

The A Series *ComfortLink* controls will use one of the following control methods:

Two-stage control — The unit will operate in LOW HEAT or HIGH HEAT mode as determined by the demand inputs. In the LOW HEAT mode if the temperature sensed by the evaporator discharge temperature sensor is below 50 F, the unit will automatically go into a HIGH HEAT mode.

Multiple-stage control — When the unit is in a LOW HEAT mode, the algorithm calculates the desired heat capacity based on set point and supply-air temperature. The staged gas control logic will stage the heating capacity to match the calculated demand. When the unit is in a HIGH HEAT mode, all stages of heat will be activated. Staged gas heat can also be used in a TEMPERING mode.

Tempering control — When a unit is equipped with multiple staged gas heat, tempering allows the unit to provide a neutral supply air temperature in winter climates. This mode is enabled during a VENTILATION, LOW COOL, or HIGH COOL mode when the economizer dampers are at their minimum ventilation position and the mixed-air temperature is below the supply air set point. Tempering can also be used during a preoccupancy purge to prevent low temperature air from being delivered to the space.

Economizer and IAQ options

The controls have been designed to support the requirements of indoor air quality control through the use of outside air. Units can be equipped either with an adjustable, self-closing outdoor air damper or with a fully modulating economizer with ultra-low leak dampers. The economizer can be configured for a full modulation mode or 3-position mode of operation. The control includes logic for a minimum ventilation position and different set points for occupied and unoccupied minimum position set points. This control also has logic built in to calibrate the economizer position to the actual percentage of outside air introduced. During periods when the compressors are not being used, the control will use the RAT, SAT and OAT to calibrate the economizer. This will allow for setting the outside air actual percentage, not just the percent damper position.

The use of the economizer will depend on the mode of change selected. This control integrates the changeover directly into the control. Five types of changeover are available:

- Outdoor air dry bulb
- Differential dry bulb
- Outdoor air enthalpy
- Differential enthalpy
- Outdoor air dew point

The units are provided with an outdoor air and return air temperature sensor so the first two changeover methods are available as standard. To use the enthalpy changeover options, the control supports the addition of highly reliable electronic humidity or enthalpy sensors. The humidity sensor input is then used with the dry bulb sensors to calculate the enthalpy. For outdoor enthalpy changeover the control also has the ASHRAE 90.1 A, B, C, D economizer changeover curves built into the software.

Building pressure control — When operating with outside air economizers, large amounts of air can be introduced into the building and a means must be provided for building pressure relief. The 48/50A Series control supports the following three types of building pressure control:

- Relief Dampers — Can be used on low return duct static applications
- Non-Modulating Two-Stage Power Exhaust — The unit can be equipped with multiple power exhaust fans—4 on sizes 020-050 and 6 on size 060. The software controls the power exhaust stages based on the economizer position (percent open).
- Modulating Power Exhaust — Both the VAV and CV/SAV units can be equipped with power exhaust fans that are controlled by a building pressure sensor that is connected to the *ComfortLink* controller. The fans are in groups which allow for 4 stages on sizes 020-050 and 6 stages on size 060.
- High Capacity Power Exhaust (field-installed) — Both the VAV and CV/SAV units can be equipped with the field-installed high capacity power exhaust. These motors are modulated via VFDs which are controlled by a building pressure sensor that is connected to the *ComfortLink* controller. The VFDs provide full modulation and precise building pressure control.

The units are capable of using either 2-in. or optional 4-in. pleated filters and can have an optional filter pressure drop switch to warn of dirty filter conditions.

The indoor air quality (IAQ) function provides a demand-based control for ventilation air quantity, by providing a modulating outside air damper position that is proportional to the space CO₂ level. The ventilation damper position is varied between a minimum ventilation level (based on internal sources of contaminants and CO₂ levels other than the effect of people) and the maximum design ventilation level (determined at maximum populated status in the building). During a less-than-fully populated space period, the CO₂ level will be lower than that at full-load design condition and will require less ventilation air. Reduced quantities of ventilation air will result in reduced operating costs. Space CO₂ levels are monitored and compared to user-configured set points. Accessory CO₂ sensor for space (or return duct mounting) is required. The IAQ routine can be enhanced by also installing a sensor for outdoor air (CEM required).

During the occupied period, in the absence of a demand for cooling using outside air, if CO₂ levels are below the set point for the minimum ventilation level, the outside-air damper will open to the minimum ventilation level damper position set point. The minimum damper position will be maintained as long as the CO₂ level remains below the set point.

When the space CO₂ level exceeds set point for the minimum ventilation level condition, the *ComfortLink* controls will begin to open the outside air damper position to admit more ventilation air and remove the additional contaminants. As the space CO₂ level approaches the set point for maximum design ventilation level condition, the outside air damper position will reach the maximum ventilation level damper position set point limit. Damper position will be modulated in a directly proportional

Controls (cont)



relationship between these two CO₂ set point limits and their corresponding damper position limits.

In most applications a fixed reference value can be set for the outdoor air quality level, but the control also supports (with optional CEM) the addition of an outdoor air quality sensor that will be compared to the indoor or return IAQ sensor. If an OAQ (outdoor air quality) sensor is connected, the demand set point levels will be adjusted automatically as the outdoor CO₂ levels vary. Also, if the outdoor CO₂ level exceeds a user-configured maximum limit value, then outside air damper position will be limited to the minimum ventilation damper set point value. The control can also receive these signals through the CCN system.

The IAQ and OAQ measurement levels are displayed by the *ComfortLink* scrolling marquee in parts per million (ppm).

Fire and smoke controls interface — The unit can be equipped with an optional return air smoke detector. The smoke detector is wired to stop the unit and send a message to a remote alarm system if a fault condition is detected. If the controls expansion module (CEM) is added, the control will support smoke control modes including evacuation, smoke purge, and pressurization.

Demand limiting — The control supports demand limiting using one or two fixed capacity limits initiated by discrete input switches or a variable capacity limit function based on an analog input signal. On CCN systems this can be done through the network, or for non-CCN network jobs this can be done by adding the controls expansion module.

Diagnostics

The *ComfortLink* controls have fully integrated all controls and sensors into a common control system. The control monitors these inputs as well as many of the routines to provide advanced diagnostics and prognostics. These include adaptive logic to allow the unit to continue to operate in a reduced output mode and automatic resets where applicable. The last 10 alarms and alerts are stored in memory and can be accessed through the display. The alarms can also be monitored through the Carrier Comfort Network® connection or building automation system. The unit also supports the use of the hand-held Navigator™ display which can be plugged in at the main control box and auxiliary control box at the opposite end of the unit.

Some of the diagnostics that are included are:

- Monitoring of all sensors
- Suction pressure transducers to provide compressor protection and coil freeze protection
- Monitoring of the economizer actuator via digital communication
- Monitoring of compressor status using compressor protection boards
- Adaptive logic for low supply-air temperatures
- Compressor lockout at low ambient conditions
- Storage of compressor run hours and starts
- Low refrigerant charge protection
- Compressor reverse rotation protection

Control interface

The *ComfortLink* controller can interface with the i-Vu® Open Control System, a BACnet building automation

system, or Carrier Comfort Network® devices. This will allow for the use of all system control programs. These include:

- Network Service Tool
- System Pilot™ device
- Touch Pilot™ device
- i-Vu® Open Control System software
- ComfortView™ software
- CCN Web software
- ComfortID™ system

Contact Carrier Controls Marketing for more information.

The control can also provide interface with other energy management systems with the addition of either the BACnet communication option, the MODBUS Carrier translator, or the LonWorks Carrier translator.

Several contact connection points have been provided in the main control box for interface to external controls and for easy third party control. These are summarized in the Interface Connections table on page 117. External controls use the following interface points:

- Start/Stop (On/Off) — Start/Stop is accomplished with a contact closure between terminals 1 and 3 on TB6.
- Remote Economizer Enable — Enabling and disabling of the economizer can be done by connecting a contact closure to terminals 1 and 2 on TB6. The economizer can be configured for a switch closure changeover for 3-position operation.
- VAV Heating Interlock — Interface with non-linkage terminals can be done through TB5 terminal 1 and 2.
- Remote IAQ Inputs — External IAQ demand inputs can be connected through terminals 6 and 7 on TB5.
- Smoke Detectors Alarm Output — Remote detector alarm outputs can be connected through terminals 8 and 9 on TB5.
- Fire Shutdown — A remote fire shutdown signal can be connected to 10 and 11 on TB5. The software can be configured to shut the unit down on an open or closed signal.
- Fire Pressurization — For a remote control of pressurization a contact closer can be connected to terminals 12 and 13 on TB5. In this mode the economizer damper will be fully opened and the supply fan turned on to pressurize the space.
- Fire Evacuation — For this mode a remote contact closure can be connected to terminal 12 and 14 on TB5. For remote evacuation of a space the outside-air dampers will be opened and the power exhaust fans turned on to evacuate the space of smoke.
- Fire Purge — For this mode external contacts can be connected to terminals 12 and 15 on TB5. In this mode the supply fan and return fans will be turned on with the economizer at a full open position.
- Demand Limiting — For demand limiting the controls expansion module (CEM) must be used. Connections are provided on TB6 for switch input demand limiting and for 4 to 20 mA demand limit signals.
- Dehumidification — A discrete input is available on TB6 to initiate the Dehumidification mode. This input is shared with one of the demand limiting inputs and requires the controls expansion module.

- Remote Supply Air Set Point — A remote supply air temperature set point can be supported when the controls expansion module is used. It can be connected to terminals 9 and 10 on TB6.
- Outdoor Air IAQ Signal — If an external outdoor air signal is being used then it can be connected to terminals 11 and 12 on TB6.
- IAQ Switch Input — If an external control will be controlling IAQ then it can be connected as a contact closure through terminals 13 and 14 on TB6.

Carrier can also support electronic interface to other systems using the following;

- MODBUS Carrier translator (read/write, provides CCN to MODBUS remote terminal unit [RTU] protocol conversion)
- LonWorks Carrier translator (read/write, provides CCN to LON FT-10A ANSI/EIA-709.1 protocol conversion)

Constant volume/staged volume applications

The 48/50A2,A4 units are designed to operate in CV/SAV™ applications. The units are shipped as operable, stand-alone units using either a standard (mechanical or electronic) 2-stage heat or 2-stage cool thermostat, or with an electronic room temperature sensor and a timeclock to establish unit start and stop times.

With a standard thermostat (programmable is optional), heating and cooling operation is set by space temperature.

With a space sensor and field-supplied timeclock, the machine will operate at default values unless they are changed using appropriate input devices. The space sensor monitors space temperature and may be equipped with a timed override feature, which allows unit operation during unoccupied periods. The space sensors may be used in multiples of 4 or 9 to achieve space temperature averaging. The use of a space sensor also allows the unit to be turned on and off from a remote signal or it can be programmed to use the time of day scheduling that is built into the control.

Supply air can be supplied at a constant volume, or at staged air volumes corresponding to two configurable speeds. Features with thermostat control of unit

- Two-stage heating (if installed)
- Multiple stage gas heating if unit is equipped with the staged gas heat option
- Two-stage demand with fully proportional economizers and integrated compressor capacity
- Adaptive multiple stage cooling which can provide up to 5 stages of capacity
- Control of unit using Y1, Y2, W1, W2, and G thermostat or T55 or T56 space sensors
- Outdoor-air temperature/supply-air temperature monitoring with logic to lock the compressors out at low ambient temperatures down to 0° F
- Control of modulating economizer for free cooling
- Control to maximize the use of outside air cooling to reduce part load operating costs

- Control of the power exhaust fans based on configurable damper positions or directly from the optional building pressure sensor
- Compressor time guard override (power up and minimum on and off timers)
- Support of IAQ sensor

INTERFACE CONNECTIONS

TB-3 — CCN COMMUNICATIONS (HY84HA096)

TB3	1	LEN +
	2	LEN C
	3	LEN -
	4	24 VAC
	5	CCN +
	6	CCN c
	7	CCN -
	8	Grd

TB-4 — THERMOSTAT CONNECTIONS (HY84HA090)

TB4	1	Thermostat R
	2	Thermostat Y1
	3	Thermostat Y2
	4	Thermostat W1
	5	Thermostat W2
	6	Thermostat G
	7	Thermostat C
	8	Thermostat X

TB-5 — FIELD CONNECTIONS (HY84HA101)

TB5	1	VAV Heater Interlock Relay, Ground
	2	VAV Heater Interlock Relay, 24 VAC
	3	T55/T56 10K Thermistor
	4	T55/T56 10K Thermistor
	5	T56 Set Point Adjustment (100,000 ohm)
	6	Indoor Air IAQ Remote Sensor/Remote Pot/Remote 4-20 mA
	7	Indoor Air IAQ Remote Sensor/Remote Pot/Remote 4-20 mA
	8	Smoke Detector Remote Alarm
	9	Smoke Detector Remote Alarm
	10	Fire Shutdown
	11	Fire Shutdown
	12	Fire Control Common*
	13	Fire Pressurization*
	14	Fire Evacuation*
	15	Fire Smoke Purge*
	16	Not Used

TB-6 — FIELD CONNECTIONS (HY84HA101)

TB6	1	Remote Occupied/Economizer Enable 24 VAC
	2	Remote Occupied Contact
	3	Remote Economizer Contact
	4	Demand Limit Contacts Common*
	5	Demand Limit Switch 1*
	6	Demand Limit Switch 2/Dehumidify Switch*
	7	Demand Limit 4-20 mA*
	8	Demand Limit 4-20 mA*
	9	Remote Supply Air Set Point 4-20 mA*
	10	Remote Supply Air Set Point 4-20 mA*
	11	Outdoor Air IAQ 4-20 mA*
	12	Outdoor Air IAQ 4-20 mA*
	13	IAQ Remote Switch Common*
	14	IAQ Remote Switch*
	15	Supply Fan Status Switch*
	16	Supply Fan Status Switch*

* Optional controls expansion module (CEM) is required.

Controls (cont)



Features with sensor control of unit

There are 2 sensor options available:

- T55 sensor will monitor room temperature and provide unoccupied override capability (1 to 4 hours).
- T56 sensor will monitor room temperature, provide unoccupied override capability (1 to 4 hours), and provide a temperature offset of 5° F maximum.

Standard features are:

- Support of remote occupied/unoccupied input to start and stop the unit
- Two-stage economizer demand with fully proportional economizers and integrated compressor capacity
- Variable capacity control with variable capacity compressor option
- Cooling capacity with adaptive control, with up to 5 stages of mechanical refrigeration capacity
- Occupied or unoccupied set point
- Enable heating (if installed) or cooling during unoccupied periods as required to maintain space temperature within the unoccupied set points
- Adjustment of space temperature set points of $\pm 5^\circ$ F when using a T56 sensor
- Support of IAQ sensor
- 365-day timeclock with backup (supports minute, hour, and day of week, date, month, and year access). The timeclock includes the following features:
 - Daylight savings time function
 - Occupancy control with 8 periods for unit operation
 - Holiday table containing up to 18 holiday schedules
 - Ability to initiate timed override from T55 or T56 sensors (for a timed period of 1 to 4 hours)
 - Temperature-compensated start to calculate early start times before occupancy
 - For units connected into a CCN network, the timeclock can be integrated into the overall building energy management system and be updated remotely
- For units connected to the CCN network the user can also display all the unit information including I/O values Maintenance, Configuration, Service, and Set Point data tables

Variable air volume (VAV) applications

The 48/50A3,A5 units are designed to operate in VAV applications. As standard they include a supply fan inverter (VFD) to control the supply fan speed and duct pressure. They are designed to control the leaving-air temperature in cooling to a configurable set point. The changes in mode of operation from Heating to Vent to Cooling mode can be controlled either from the return air temperature sensor or from an accessory space temperature sensor. Some of the features for VAV units in a stand-alone application are:

- The units are shipped as operable, stand-alone units with the addition of a field-supplied timeclock to establish unit start and stop times or they can use *ComfortLink* time of day scheduling routine
- Provides cooling and heating control (if equipped with heat) in both occupied and unoccupied modes

- Supports an optional space temperature sensor for mode control and supply air temperature reset
- If space sensor is equipped with an override feature, the sensor will allow operation during the unoccupied period for a fixed length of time
- Base unit control supports a heat interlock relay (field supplied) to signal the VAV terminal devices to fully open during heating operation
- Control board diagnostics
- Control of modulating economizer for free cooling
- Control to maximize the use of outside air cooling to reduce part load operating costs
- Support of remote occupied/unoccupied input to start
- Controls the operation of the supply fan inverter to maintain a configurable supply duct static pressure set point. Inverter is configured and controlled directly by *ComfortLink* controls
- Support of IAQ sensor
- Support a field test for field check out
- Support linkage to *ComfortID™* systems
- Cooling capacity control of up to 5 stages plus economizer
- Control of heat to maintain return-air temperature
- Control of heat interlock relay
- Compressor time delays to prevent rapid cycling of compressors
- Automatic lead-lag control of compressors to reduce the number of compressor cycles
- With the addition of a remote start/stop switch, heating or cooling is enabled during unoccupied periods as required to maintain space temperature to within unoccupied set points
- With the addition of the controls expansion board, the *ComfortLink* controls will also support demand limiting and remote set point control

When the unit is connected to a CCN (Carrier Comfort Network®) system, additional features can be used:

- Interface of the unit clock with the CCN network clock and allow for remote configuration of the schedules
- CCN demand limit participation
- Interface with *ComfortID™* control systems through linkage

Sequence of operation

Cooling, constant volume (CV)/staged air volume (SAV™) units — On power up, the initialization software will determine the unit configuration and also initialize any controls loops and input/output devices. All alarms and configurations are saved in memory and maintained during power outages. All alarms will be maintained in memory and must be cleared through the display.

On SAV units equipped with a supply fan VFD, the fan is controlled at discrete speeds based on the operation mode of the unit.

Fan will operate in Low speed when:

- Cooling capacity is less than 50%
- In ventilation mode
- Heating is less than 75% capacity

Fan will operate in High speed when:

- Cooling capacity is greater than 50%
- Heating capacity is greater than 75% capacity

Constant volume/staged air volume conventional thermostat control — If the unit is equipped with a conventional thermostat with Y1, Y2, W1, W2, and G connections, then the control will perform the following sequence.

When G is closed the indoor fan will turn on. G must be closed for heating or cooling to occur.

If Y1 is closed, then the control will first check the ability to use the economizer. If the economizer can be used, the control will modulate the damper open to maintain the low load economizer leaving air temperature set point.

If Y2 closes, then the control will lower the leaving air temperature set point to the configured set point. If the economizer cannot satisfy the load, then compressors will be sequenced on to maintain either the low or high load temperature set points. If the economizer cannot be used or the enable control disables the economizer, then the control will sequence the compressors based on the Y1 and Y2 signals.

If two-stage control has been selected, then the control will map the compressors to the Y1 and Y2 inputs as defined in the loading sequence.

If Adaptive mode has been selected, then the control will add and remove compressor stages to maintain the low and high demand leaving air set points. If Y1 is closed, at least one compressor stage will be turned on.

Heating — If W1 closes, then it will indicate that the units should be in the Heating mode. The economizer will be closed to the minimum position, and if the unit is equipped with gas or electric heat then the first stage of heat will be energized. If W2 closes, then the control will turn on the second stage of heat. If the unit is equipped with a staged gas heat control option, then the W1 signal will be used to control the gas heat to the configurable low heat load leaving air temperature set point. When W2 is energized, the unit will fire all stages of heat capacity. If the unit is equipped with gas heat, then the IGC board will control the operation of the gas heat. See the 48 Series Gas Heat units section for the IGC board sequence of operation.

Constant volume/staged air volume space temperature sensor control — If the space temperature operation has been selected using a T55, T56, or T59 sensor, then the following logic will be used to control the operation of the unit. If a space temperature is used, then a wire jumper must be added between R, W1, and W2. If a remote occupancy control method has been selected, then the input must first be closed for the unit to go into Heat, Vent or Cooling mode.

If the internal timeclock is used, the control module determines the occupancy state based on the system time schedules.

If Temperature Compensated Start is active, the unit will be controlled as in the occupied mode and will start a time as determined by prior operation to have the space at set point by the occupied time.

If the unit has been configured for a preoccupancy purge, then the control will start the unit in Vent mode prior to the occupancy time to vent the space. If an IAQ sensor is being used and the low IAQ set point is satisfied, then the occupancy purge mode will be terminated. The

set points for heat and cooling are configurable through the display. If a T56 sensor is being used, then the set point can be shifted by as much as 5 degrees.

Cooling — If the space temperature goes above the cooling set point, then the unit will go into Cooling mode. If the economizer can be used, the control will first try to control to the leaving air temperature set point. The set point will depend on the space temperature. If the temperature is above the low demand set point, then the low economizer load discharge air temperature set point will be used. If the temperature is above the high load space temperature set point, then the high load leaving air temperature set point will be used. If the economizer cannot satisfy the load, then compressors will be sequenced on to maintain either the low or high load temperature set points.

If the economizer cannot be used or the enable control disables the economizer, then the control will sequence the compressors based on the low and high load space temperature variables. If two-stage control has been selected, then the control will map the compressors to the low and high loads as defined in the loading sequence. If Adaptive mode has been selected, then the control will add and remove compressor stages to maintain the high and low demand leaving air set points.

Heating — If the space temperature goes below the heating space temperature set points, then it will indicate that the units should be in the Heating mode. The economizer will be closed to the minimum position and if the unit is equipped with gas or electric heat then the first stage of heat will be energized. If the space temperature goes below the high load space temperature set point, then the control will turn on the second stage of heat. If the unit is equipped with a staged gas heat control option, then the low load demand signal will turn on heating stages to maintain the leaving air temperature set point. A high demand signal will energize all stages of heat.

Unoccupied Mode — If the unit is configured for unoccupied free cooling, mechanical cooling, or heating, and the temperature goes beyond the unoccupied configuration set points, then the control will turn on free cooling, mechanical cooling, or heat as needed to get within the unoccupied set points. When in this mode, the economizer dampers will be maintained fully closed or to the minimum unoccupied ventilation set point.

Variable air volume control — On power up, the initialization software will determine the unit configuration and also initialize any controls loops and input/output devices. All alarms and configurations are saved in memory and maintained during power outages. All alarms will be maintained in memory and must be cleared through the display.

The unit will first determine the mode of operation. If the unit has been configured for space temperature demand, then the control will determine, based on the configurable set points, if the unit should be in heat mode, vent mode, or cooling mode. If the unit is configured for return air temperature control, then it will start the fan and monitor the return air temperature vs. the configurable set point to determine if the unit should be in cooling, vent, or heating mode.

Controls (cont)



If the control is connected to a ComfortID™ system, the room terminals are equipped with microprocessor controls that give commands to the base module. If linkage is active, the control module will replace local *ComfortLink* set points and occupancy data with linkage-supplied data.

If temperature compensated start is active, then advance pre-cool or heat of the space is enabled. If the unit is configured to use a pre-purge cycle, then the *ComfortLink* controls will start the unit in Vent mode based on a pre-start time interval. If an IAQ sensor is being used and the low IAQ control point is satisfied, then the mode will be terminated.

Cooling — If Cooling mode is required, then the controlling set point will be the leaving air temperature set point. If an economizer is present and the changeover control allows the economizer to be used, then it will first attempt to control the leaving-air temperature using free cooling. If this cannot satisfy the load, then additional compressor stages will be turned on to maintain the leaving-air temperature. When both compressors and economizers are being used, the control will use the economizer dampers to maintain better control of the leaving air and to help prevent high compressor cycling. If the economizer cannot be used, then it will be set to the minimum vent position. When using compressors, the leaving-air temperature will sequence to compressors on and off using a PID control loop.

If the unit is equipped with an optional hot gas bypass valve, the control will use the hot gas as an additional stage of capacity. When the first stage of cooling is required the control will turn on a circuit “A” compressor and the hot gas bypass valve. When additional cooling is called for it will turn off the hot gas bypass valve. The valve will also be used for additional freeze protection of the coils when low evaporator refrigerant temperatures are detected using the suction pressure transducers.

When operating in cooling mode, the control will also monitor the supply duct pressure and send a 4 to 20 mA signal to the factory-supplied inverter to control the speed of the fan and the delivered cfm. If on a linkage system, the control will also support static pressure reset based on the needs of the zones.

Heating — If the unit has been enabled for occupied heat and the space temperature sensor (SPT), return air temperature sensor (RAT), or linkage demand calls for heat, the control will energize the electric heat or gas heat (if present) to warm the space. In this mode the control will energize the heat interlock relay which will signal the terminals to open to the heating position. Note that for the linkage systems the interlock relay connection is not required. Once the Heat mode is enabled, the heat capacity will be controlled by the return air temperature set point. Heating will continue until the return temperature set point is satisfied. If the unit is configured for morning warm-up and the heating demand is below the set point during the first 10 minutes of operation, the control will energize full heating capacity until the return air temperature set point is satisfied.

If the space temperature sensor (SPT), return air temperature sensor (RAT), or linkage demand requires that the unit be in heating, then the control will energize the electric heat or gas heat (if present) to warm the space. In this mode the control will energize the heat interlock relay which should be

connected to the terminals to indicate that they should open to the heating position. The interlock relay connection is not required for the linkage systems. Heating will continue until the mode selection sensor is satisfied.

Dehumidification mode — A Dehumidification mode can be initiated by either a discrete input on TB6 or by a direct measurement of humidity levels with an optional space or return air humidity sensor. When the Dehumidification mode is active, the evaporator coil leaving air temperature will be controlled to the Dehumidify Cool set point, which is typically colder than the normal cool mode leaving air set points.

In this mode, comfort condition set points, which are based on dry bulb temperature, will be overridden. If a source of reheat is available, then the leaving-air temperature can be raised to a more desirable temperature. Available methods of reheat are internal gas heat if the unit is equipped with the staged gas heating option or an external heat source that can be controlled by an auxiliary alarm relay switch.

Humidi-MiZer® operation — The design of the Humidi-MiZer adaptive dehumidification system allows for two humidity control modes of operation of the rooftop unit, utilizing a common subcooling/reheat dehumidification coil located downstream of the standard evaporator coil.

This unique and innovative design provides the capability for the rooftop unit to operate in both a subcooling mode and a hot gas reheat mode for maximum system flexibility. The Humidi-MiZer package is factory installed and will operate whenever there is a dehumidification requirement.

The Humidi-MiZer system is initiated based on input from a factory-installed return air humidity sensor to the large rooftop unit controller. Additionally, the unit controller may receive an input from a field-installed space humidity sensor, a discrete input from a mechanical humidistat, or input from a third-party controller.

A unit equipped with a Humidi-MiZer system can operate in the following modes:

Conventional Cooling mode — Conventional operation of the A series large rooftop unit allows the unit to cycle up to six compressors to maintain comfort conditions, with expanded cycling operation offered by the optional digital compressor. This mode is the conventional DX (direct expansion) cooling method used on Carrier's standard large rooftops and provides equivalent capacity to a non-Humidi-MiZer equipped unit. It is used when there is a call for cooling only, such as at design AHRI (Air-Conditioning, Heating, and Refrigeration Institute) cooling conditions of 95 F ambient and 80 F/67 F db/wb entering air conditions. The SHR (sensible heat ratio) for equipment in this scenario is typically 0.7 or higher.

Subcooling mode — This modulating mode will operate to satisfy part load type conditions when there is a space call for cooling and dehumidification. Although the temperature (sensible) may have dropped and decreased the sensible load in the space, the outdoor and/or space humidity levels may have risen.

A typical scenario might be when the outside air is 85 F and 70 to 80% relative humidity (RH). Desired SHR for

equipment in this scenario is typically 0.4 to 0.7. Carrier's A Series Humidi-MiZer adaptive dehumidification system will increase subcooling entering the evaporator and cycle on enough compressors to meet the latent load requirement, while simultaneously adjusting refrigerant flow to the Humidi-MiZer coil to reheat the air to the required supply air set point. This will allow the unit to provide variable SHR to meet space requirements.

Conversely, a standard unit might overcool the space or stage down to meet set point, sacrificing latent capacity control. The Humidi-MiZer unit will initiate subcooling mode when the space temperature and humidity are both above the temperature and humidity set points, and attempt to meet both requirements. Once the humidity requirement is met, the unit can continue to operate in normal cooling mode to meet any remaining sensible capacity load. Alternatively, if the sensible load is met and humidity levels remain high, the unit can switch to Hot Gas Reheat mode to provide neutral, dehumidified air.

Hot Gas Reheat mode — This modulating mode is used when dehumidification is required without a need for cooling, such as when the outside air is at a neutral temperature (70 to 75 F) but high humidity exists. This situation requires the equipment to operate at a SHR of 0.0 to 0.2.

With no cooling requirement and a call for dehumidification, the A Series Humidi-MiZer adaptive dehumidification system will cycle on enough compressors to meet the latent load requirement, while simultaneously modulating refrigerant flow to the Humidi-MiZer® coil to reheat the air to the desired neutral air set point.

The A-Series Humid-MiZer system controls allow for the discharge air to be reheated either to the return-air temperature minus a configurable offset or to a configurable Reheat set point (default 70 F). The Hot Gas Reheat mode will be initiated when only the humidity is above the humidity set point, without a demand for cooling.

Mode control — The essential difference between the Subcooling mode and the Hot Gas Reheat mode is in the supply air set point. In Subcooling mode, the supply air set point is the temperature required to provide cooling to the space. In Reheat mode, the supply air set point is the temperature required to provide neutral air to the space. In both cases, the unit will decrease the evaporator discharge temperature to meet the latent load and reheat the air to the required cooling or reheat set point (i.e., 50, 60, 70 F, etc.).

48 series gas heat units

The gas heat units incorporate 2 (3 on size 060) separate systems to provide gas heat. Each system incorporates its own induced-draft motor, integrated gas control (IGC) board, 2-stage gas valve, manifold, and safeties. For 2-stage heat control, the systems are operated in parallel. For example, when there is a call for first stage heat, both induced-draft motors operate, both gas valves are energized, and both IGC boards initiate spark.

With the staged gas control, the systems are operated independently to allow for a greater range of capacity control. All of the gas heating control is performed through the IGC boards (located in the heating section). The MBB module board serves only to initiate and terminate heating operation and monitor the status of the requirements for indoor fan operation.

The fan will be controlled directly by the MBB board. The base module board is powered by 24 vac. When the thermostat or room sensor calls for heating, the MBB board will close heating relays and send power to W on each of the IGC boards.

An LED on the IGC board will be on during normal operation. A check is made to ensure that the rollout switches and limit switches are closed and the induced-draft motors are not running. After the induced-draft motors are energized and speed is proven with the Hall Effect sensor on the motor, the ignition activation period begins. The burners will ignite within 5 seconds.

When ignition occurs, the IGC board will continue to monitor the condition of the rollout and limit switches, the Hall Effect sensor, and the flame sensor. If the unit is controlled through a room thermostat set for fan auto., 45 seconds after ignition occurs the indoor-fan motor will be energized and the outdoor-air dampers will open to their minimum position.

If the overtemperature limit opens prior to the start of the indoor fan blower, on the next attempt the 45-second delay will be shortened to 5 seconds less than the time from initiation of heat to when the limit tripped. Gas will not be interrupted to the burners and heating will continue. Once modified, the fan on delay will not change back to 45 seconds unless power is reset to the control.

If the unit is controlled through a room sensor, the indoor fan will be operating in the occupied mode and the outdoor-air dampers will be in the minimum position. If the unit is controlled with a room sensor in the unoccupied mode, the indoor fan will be energized through the IGC board with a 45-second delay and the outside-air dampers will move to the minimum unoccupied set point.

When additional heat is required, the second stage MBB output relay closes and initiates power to the second stage of all main gas valves in all sections. When the demand is satisfied, MBB heat output relays will open and the gas valves close, interrupting the flow of gas to the main burners. If the call for stage 1 heat lasts less than 1 minute, the heating cycle will not terminate until 1 minute after W1 became active. If the unit is configured for intermittent fan, the indoor-fan motor will continue to operate for an additional 45 seconds, then stop, and the outdoor-air dampers will close. If the overtemperature limit opens after the indoor motor is stopped within 10 minutes of W1 becoming inactive, on the next cycle the time will be extended by 15 seconds. The maximum delay is 3 minutes. Once modified, the fan off delay will not change back to 45 seconds unless power is reset to the control.

Application data



Ductwork — Secure vertical discharge ductwork to roof curb. Interior installation may proceed before unit is set in place on roof. For horizontal discharge applications, attach ductwork to unit, or field-supplied flanges can be attached to horizontal discharge openings and all ductwork attached to flanges. Units equipped with electric heat require a 90-degree elbow below the unit supply duct connection.

Thru-the-curb service connections — Roof curb connections allow field power wires and control wires to enter through the roof curb opening.

Thermostat (CV only) — Use of a thermistor-type room sensor is recommended on all CCN installations. A thermistor-type room sensor or a 2-stage heating/cooling thermostat may be used for all other units.

Heating-to-cooling changeover — All units are automatic changeover from heating to cooling when automatic changeover thermostat and subbase or a thermistor-type room sensor are used.

Airflow — Units are draw-thru on cooling and blow-thru on heating.

Maximum airflow — To minimize the possibility of condensate blow-off from evaporator, airflow through units should not exceed values shown in Cooling Cfm Operating Range table and Cooling Capacities tables.

Minimum airflow — The minimum airflow for cooling is 300 cfm/ton for constant volume units and 70 cfm/ton for VAV (variable air volume) units. Performance at 70 cfm/ton is limited to unloaded operation and may be additionally limited by entering-air temperatures or Humidi-MiZer operation. Refer to Gas Heating Capacities and Efficiencies table on page 7 for minimum airflow cfm for heating.

Minimum ambient cooling operation temperature — All units are equipped with factory economizers to allow free cooling at any outdoor ambient. If mechanical cooling is required, the units are designed to operate at outdoor temperatures down to 32 F. Motormaster® V control units can operate at outdoor temperatures down to -20 F.

Carrier recommends the installation of field-fabricated wind baffles on all vertically oriented condenser coil surfaces when operating in environments with prevailing winds of more than 5 mph and where temperatures drop below 32 F.

Maximum operating outdoor-air temperature — The maximum operating outdoor-air temperature is 115 F. Some models will operate up to 125 F depending on model and operating conditions.

High altitude (gas heat units only) — A change to the gas orifice may be required at high altitudes. Refer to Altitude Compensation table on page 9.

Minimum temperature — Minimum allowable temperature of mixed air entering the heat exchanger during half rate (first stage) operation is 50 F. There is no minimum mixture temperature during full-rate operation. Comfort conditioning may be compromised at temperatures below 50 F. Below 50 F entering-air temperature (EAT) both stages of heat are engaged.

Internal unit design — Due to Carrier's internal unit design (draw-thru over the motor), air path, and specially designed motors, the full horsepower listed in the Physical

Data table and Motor Limitations table can be used with extreme confidence. Using Carrier motors with the values listed in the Physical Data and Motor Limitations tables will not result in nuisance tripping or premature motor failure. The unit warranty will not be affected.

Electric heat — A field-supplied 90-degree elbow must be installed in the supply ductwork below the unit discharge.

Acoustical considerations — In order to minimize sound transmitted to the space, please conform to the following recommendations:

Location

- Avoid locating the unit above sound-sensitive areas. Instead, locate the unit above restrooms, storage areas, corridors, or other noise-tolerant areas.
- Avoid mounting the unit in the middle of large roof expanses between vertical supports. This will minimize the phenomenon known as roof bounce.
- Install the units close to vertical roof supports (columns or load bearing walls).
- Locate the units at least 25 feet away from critical areas. If this is not possible, the ductwork and ceiling structure should be acoustically treated.
- Consider the use of vibration isolators or an acoustic curb.

Ductwork

- Use flexible connectors between the unit and the supply and return ducts.
- Supply and return air main trunk ducts should be located over hallways and/or public areas.
- Provide trailing edge turning vanes in ductwork elbows and tees to reduce air turbulence.
- Make the ductwork as stiff as possible.
- Use round duct wherever possible because it is less noisy.
- Seal all penetrations around ductwork entering the space.
- Make sure that ceiling and wall contractors do not attach hangers or supports to ductwork.
- Provide as smooth and gradual transition as possible when connecting the rooftop unit discharge to the supply duct.
- If a ceiling plenum return is used, provide a return elbow or tee to eliminate line-of-sight noise to the space. Face the entrance of the return duct away from other adjacent units.

Acoustic insulation

- Provide acoustic interior lining for first 20 feet of supply and return duct or until the first elbow is encountered. The elbow prevents line-of-sight transmission in the supply and return ducts.
- Install a double layer of 2-in. low density quilted fiberglass acoustical pad with a 1/8-in. barium-loaded vinyl facing on top of the roof deck before building insulation and roofing installation occur. Place the material inside the curb and for 4 to 8 ft beyond the unit perimeter, dependent upon unit size (larger units require a wider apron outside the curb). Openings in the pad should only be large enough for the supply and return ducts. An alternate approach is to use two layers of gypsum board with staggered seams in addition to the acoustical pad.

ACOUSTICAL CONSIDERATIONS

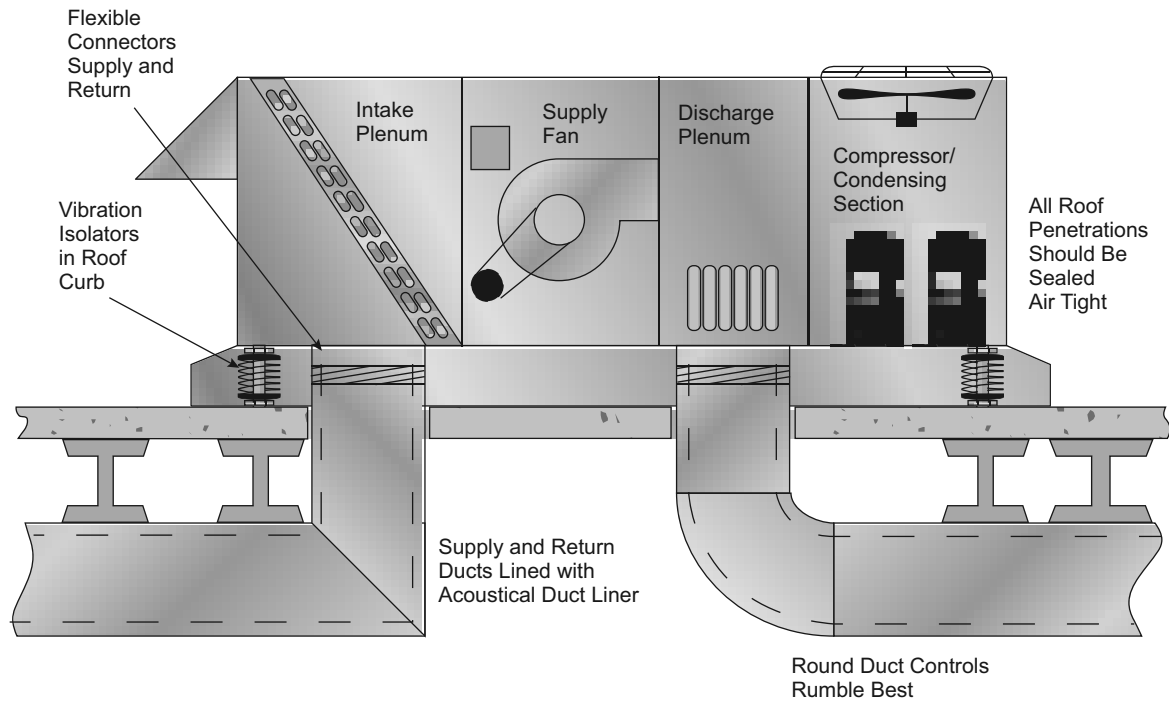

Typical wiring schematics



TYPICAL POWER SCHEMATIC (48/50A2,A3,A4,A5040 Shown)

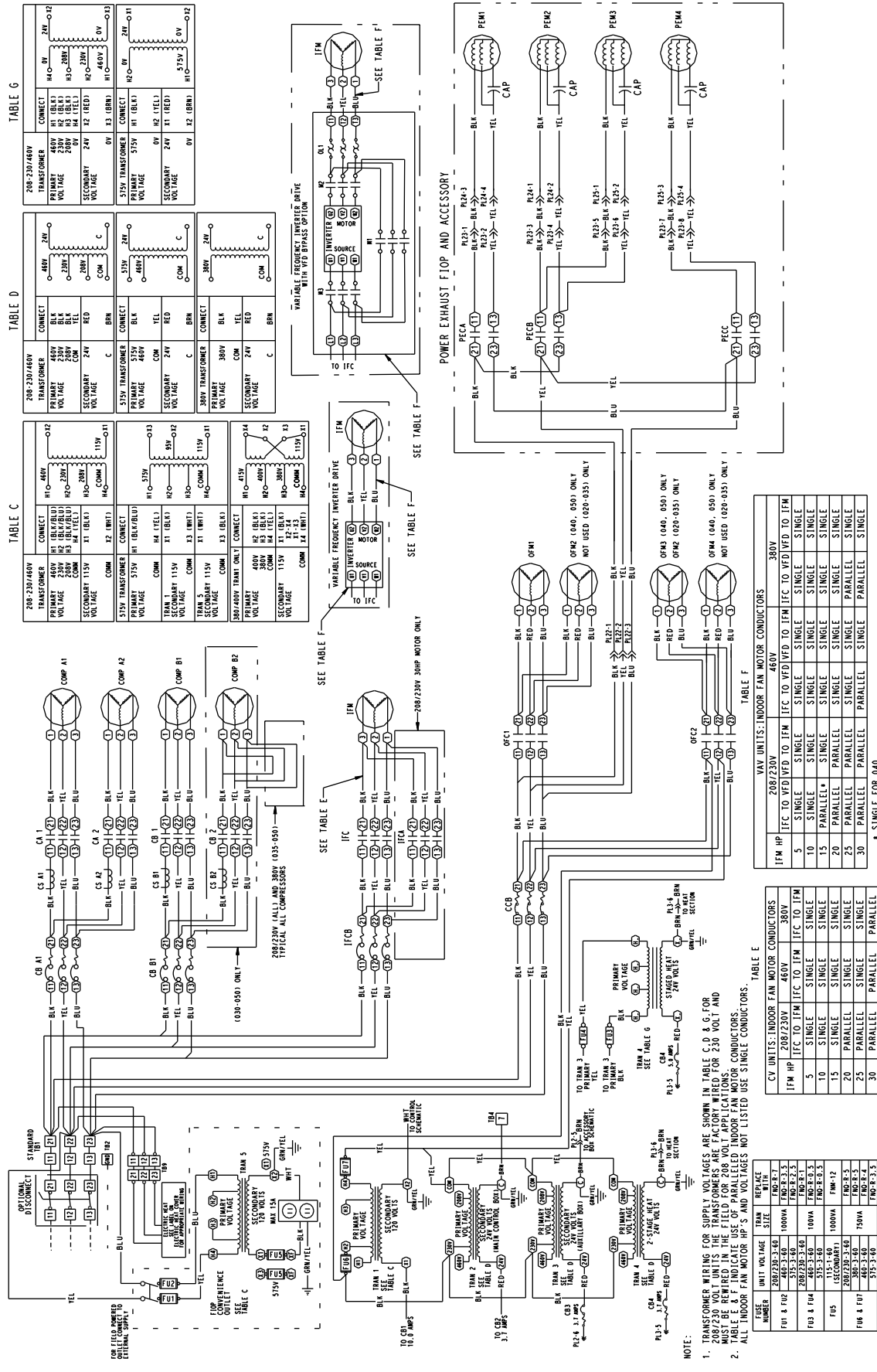

NOTE:

1. TRANSFORMER WIRING FOR SUPPLY VOLTAGES ARE SHOWN IN TABLE C, D & G. FOR 208/230V SUPPLY VOLTAGE, THE WIRING FOR 230V MUST BE USED FOR 208V APPLICATIONS.
2. TABLE E & F INDICATE USE OF PARALLEL INDOOR FAN MOTOR CONDUCTORS. ALL INDOOR FAN MOTOR HP'S AND VOLTAGES NOT LISTED USE SINGLE CONDUCTORS.

MAIN BOX CONTROL SCHEMATIC 48/50A2,A3,A4,A5020-060

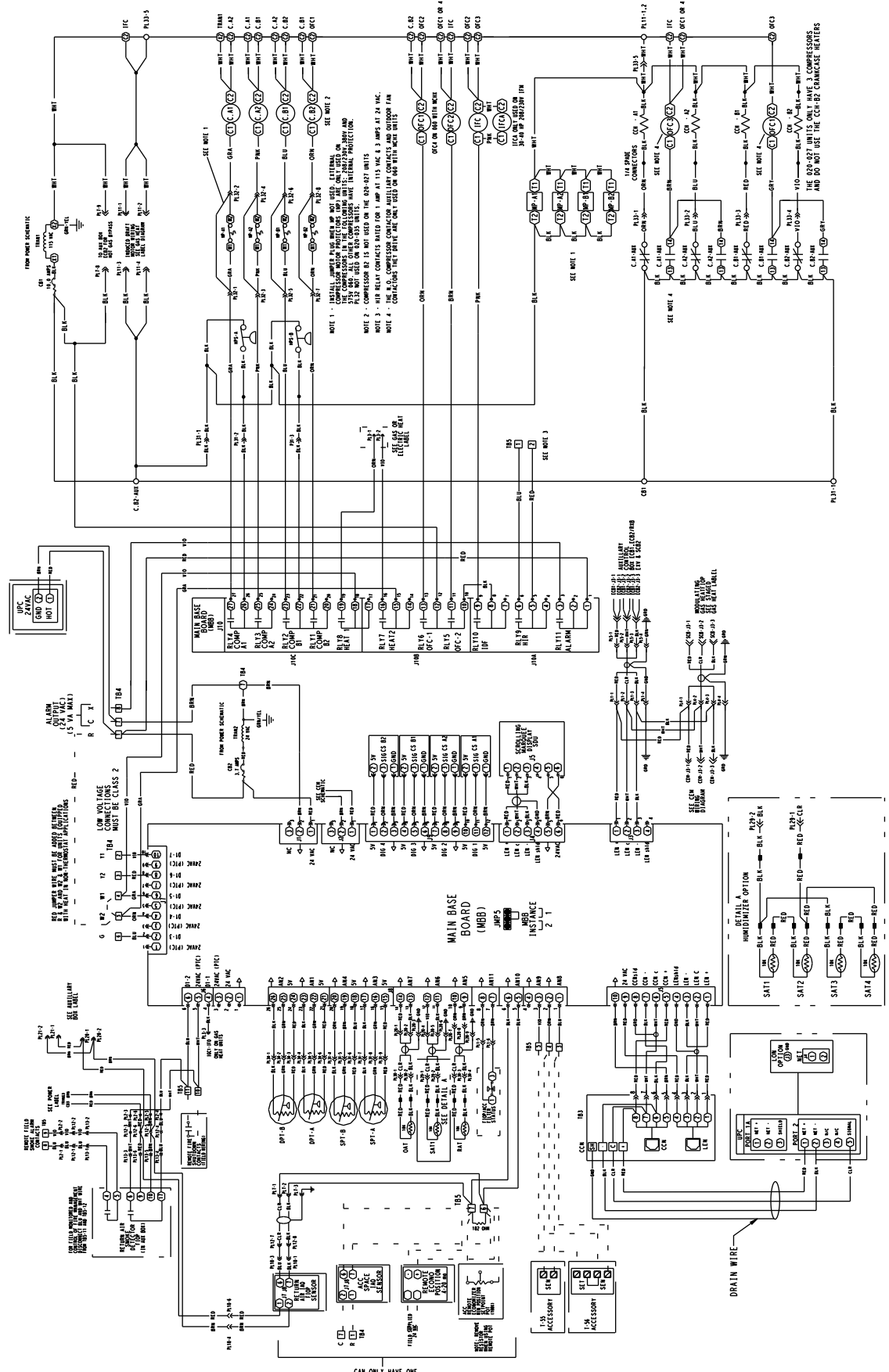

CONTROLS EXPANSION MODULE WIRING SCHEMATIC 48/50A2,A3,A4,A5020-060

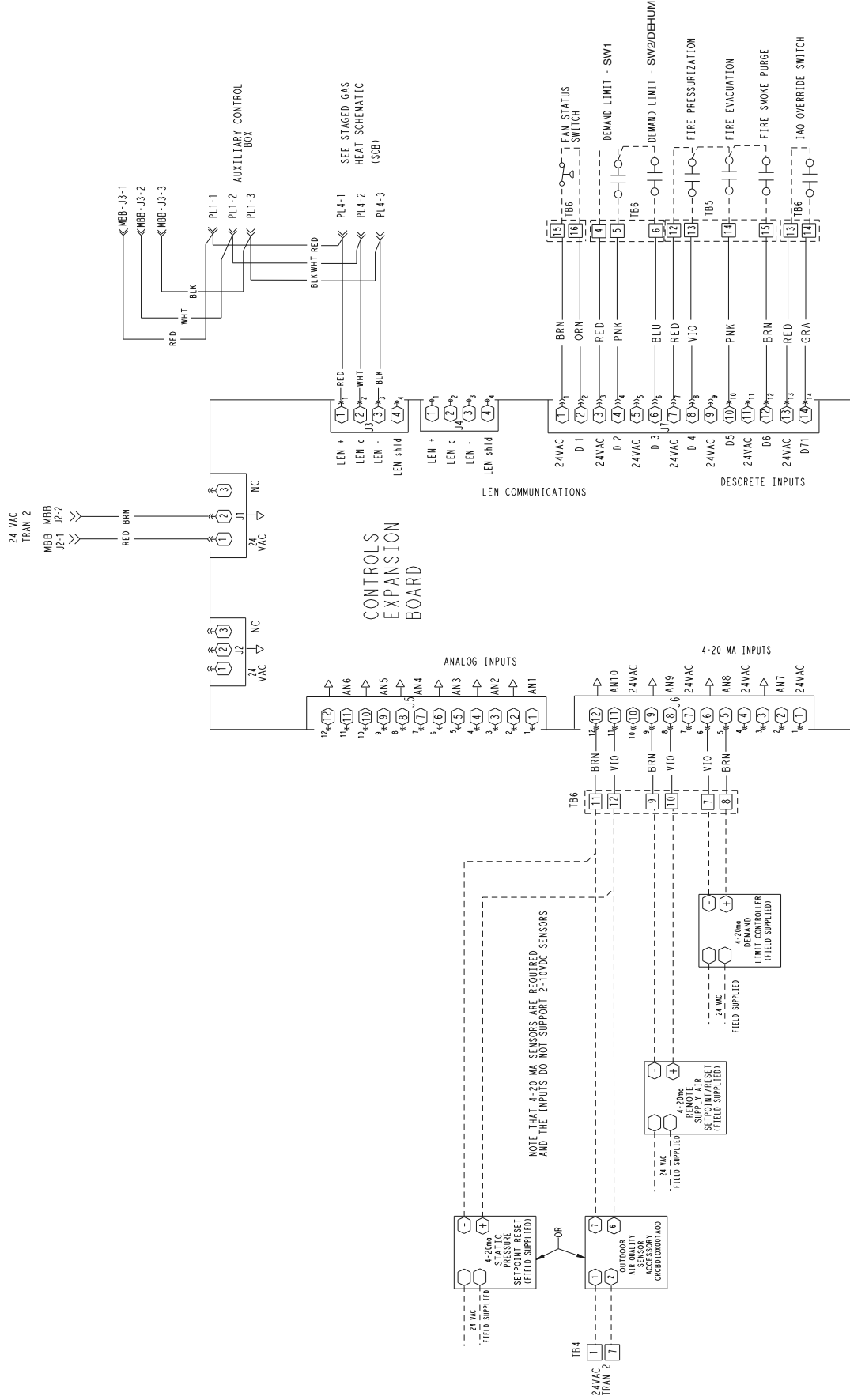

Typical wiring schematics (cont)

GAS HEAT CONTROL SCHEMATIC (TWO-STAGE HEAT) 48A2,A3020-060

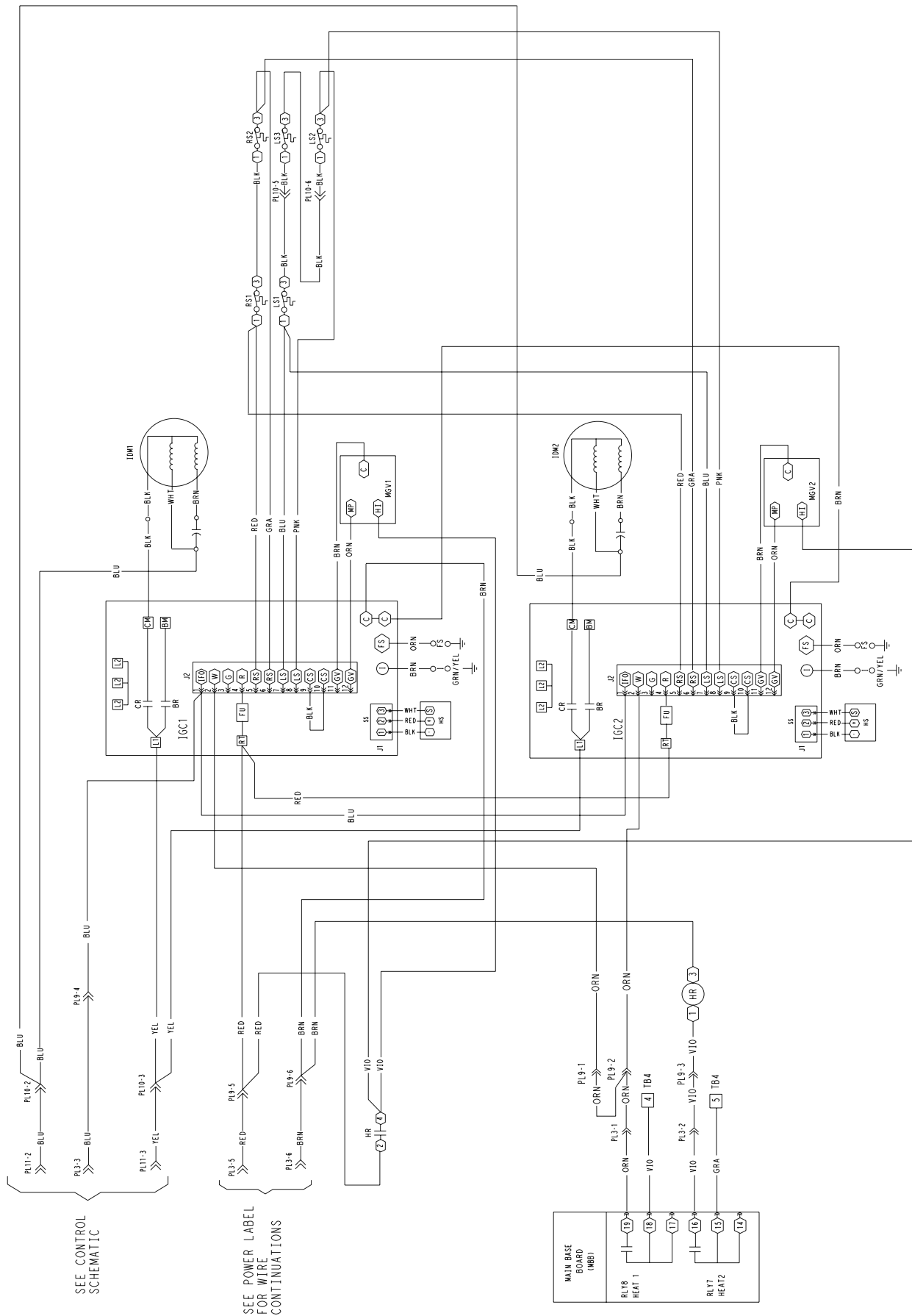

LEGEND FOR TYPICAL WIRING SCHEMATICS

LEGEND

A — Circuit A
AUX — Auxiliary Contact
BP — Building Pressure Transducer
C — Compressor Contactor
CAP — Capacitor
CB — Circuit Breaker
CCB — Control Circuit Breaker
CCH — Crankcase Heater
CCN — Carrier Comfort Network®
CCT — Cooling Coil Thermistor
CEM — Controls Expansion Module
CMR — Compressor Modulation Relay
COMP — Compressor
CS — Compressor Current Sensor Board
DP — Discharge Pressure Transducer
DPT — Discharge Pressure Transducer
DTT — Digital Scroll Discharge Temperature Thermistor

DUS — Digital Unloader Solenoid
ECB-1 — Economizer Control Board
ECB-2 — VAV Control Board
EDT — Evaporator Discharge Temperature
EXV — Expansion Valve Control Board
FIOP — Factory-Installed Option
FS — Flame Sensor
FU — Fuse
GND — Ground
HGBP — Hot Gas Bypass
HMV — Humidi-MiZer Valve
HPS — High-Pressure Switch
HR — Heat Relay
HS — Hall Effect Induced Draft Motor Switch
HVS — Humidi-MiZer Valve Solenoid
IAQ — Indoor Air Quality
IDM — Induced-Draft Motor

IFC — Indoor-Fan Contactor
IFCB — Indoor-Fan Circuit Breaker
IFM — Indoor-Fan Motor
IGC — Integrated Gas Control Board
IP — Internal Compressor Protector
LEN — Local Equipment Network
LS — Limit Switch
MBB — Main Base Board
MGV — Main Gas Valve
MMR — Motormaster Relay
MMV — Motormaster V
OARH — Outdoor Air Relative Humidity
OAT — Outdoor Air Temperature Sensor
OFC — Outdoor-Fan Contactor
OFM — Outdoor-Fan Motor
OL — Overload
PEC — Power Exhaust Contactor
PEM — Power Exhaust Motor
PL — Plug
PTC — Positive Temperature Coefficient
RARH — Return Air Relative Humidity
RAT — Return Air Temperature Sensor
RS — Rollout Switch
RXB — Rooftop Control Board
SCB — Staged Gas Heat Control Board
SCB2 — MotorMaster Control Board
SDU — Scrolling Marquee Display
SPT — Suction Pressure Transducer
T-55 — Room Temperature Sensor
T-56 — Room Temperature Sensor with Set Point
TB — Terminal Block
TRANS — Transformer
UPC — Universal Protocol Converter
VAV — Variable Air Volume
VFD — Variable Frequency Drive

THERMOSTAT MARKINGS

BM — Blower Motor
C — Common
CM — Inducer Motor
CS — Centrifugal Switch
G — Fan
IFO — Indoor Fan On
L1 — Line 1
R — Thermostat Power
RT — Power Supply
SS — Speed Sensor
W1 — Thermostat Heat Stage 1
W2 — Thermostat Heat Stage 2
X — Alarm Output
Y1 — Thermostat Cooling Stage 1
Y2 — Thermostat Cooling Stage 2

Terminal (Marked)

○ Terminal (Unmarked)

■ Terminal Block

■ Splice

— Factory Wiring

- - - Field Wiring

— To indicate common potential only, not to represent wiring.

Packaged Rooftop Cooling Unit and Packaged Rooftop Cooling Unit with Gas Heat — Constant Volume or Staged Air Volume Application

HVAC Guide Specifications — Section 48/50A2,A4

Size Range: **20 to 60 Tons, Nominal (Cooling)**

Carrier Model Number:

48A2, 48A4, 50A2, 50A4

Part 1 — General

1.01 SYSTEM DESCRIPTION

Outdoor roof curb or slab mounted, electronically controlled heating and cooling unit utilizing hermetic scroll compressors with crankcase heaters for cooling duty and with optional gas heat or electric heat. Units shall discharge supply and return air vertically or horizontally as shown on contract drawings. EER (Energy Efficiency Ratio) shall meet requirements of ASHRAE (American Society of Heating, Refrigeration and Air-Conditioning Engineers) Standard 90.1-2013.

1.02 QUALITY ASSURANCE

- A. Unit shall be rated in accordance with AHRI (Air-Conditioning, Heating, and Refrigeration Institute) Standard 340/360, latest edition.
- B. Unit shall be designed to conform to ANSI (American National Standards Institute)/ASHRAE 15, ASHRAE 62, and UL (Underwriters Laboratories) Standard 1995.
- C. Unit shall be listed by ETL and ETL, Canada as a total package.
- D. The 48A2,A4 units shall be designed to conform with ANSI Standard Z21.47 (U.S.A.) / CSA (Canadian Standards Association) Standard 2.3 (Canada), Gas-Fired Central Furnaces.
- E. Roof curb shall be designed to NRCA (National Roofing Contractors Association) criteria per Bulletin B-1986.
- F. Insulation and adhesive shall meet NFPA (National Fire Protection Association) 90A requirements for flame spread and smoke generation.
- G. The management system governing the manufacture of this product is ISO (International Organization for Standardization) 9001:2008 certified.

1.03 DELIVERY, STORAGE AND HANDLING

Unit shall be stored and handled per manufacturer's recommendations. All exposed coils shall have protective shipping covers.

Part 2 — Products

2.01 EQUIPMENT

A. General:

Factory-assembled, single-piece heating and cooling unit. Contained within the unit enclosure shall be all factory wiring, piping, refrigerant charge (R-410A), operating oil charge, dual refrigerant circuits,

microprocessor based control system and associated hardware, and all special features required prior to field start-up.

B. Unit Cabinet:

1. Constructed of galvanized steel, bonderized and precoated with a baked enamel finish.
 - a. Top cover shall be 18-gage sheet metal with 0.75-in. thick, 1.5-lb density, fiberglass insulation.
 - b. Access panels and doors shall be 20-gage sheet metal with 0.5-in. thick, 1.5-lb density, fiberglass insulation.
 - c. Corner and center posts shall be 16-gage galvanized steel.
 - d. Basepans in the heating and return air sections shall be 16-gage galvanized steel.
 - e. Basepans in the condenser section shall be 16-gage galvanized steel.
 - f. Compressor rail shall be 12-gage galvanized steel.
 - g. Condensate pan shall be 16-gage aluminized steel.
 - h. Air baffles shall be 18-gage galvanized steel with 0.5-in. thick, 1.5-lb density, fiberglass insulation.
 - i. Base rail shall be 14-gage galvanized steel.
 - j. Fan deck (indoor and outdoor section) shall be 16-gage galvanized steel.
2. Unit casing shall be capable of withstanding 500-hour salt spray exposure per ASTM (American Society for Testing and Materials) B117 (scribed specimen).
3. Sides shall have person-sized insulated hinged access doors for easy access to the control box and other areas requiring servicing. Each door shall seal against a rubber gasket to help prevent air and water leakage and be equipped to permit ease and safety during servicing.
4. Interior cabinet surfaces shall be sheet metal lined or insulated with flexible fire-retardant material, coated on the air side.
5. Unit shall have a factory-installed sloped condensate drain connection made from an aluminized steel or optional stainless steel.
6. Equipped with lifting lugs to facilitate overhead rigging.
7. Filters shall be accessible through a hinged access panel without requiring any special tools.

C. Fans:

1. Indoor Evaporator Fans:

- a. Double-width/double-inlet, centrifugal, belt driven, forward-curved type with single outlet discharge.
- b. Fan shaft bearings shall be of the pillow-block type with positive locking collar and lubrication provisions.

- c. Statically and dynamically balanced.
 - d. Evaporator fan shaft bearings shall have a life of 200,000 hours at design operating conditions in accordance with ANSI B3.15.
 - e. Solid fan shaft construction for size 020-050 units and two-piece solid fan shaft construction on the size 060 unit.
2. Condenser Fans:
- a. Fans shall be direct-driven propeller type only, with corrosion-resistant blades riveted to corrosion resistant steel supports for all size 020-050 units and the size 060 unit with optional condenser coil. Size 060 units with the microchannel condenser coil shall have a direct driven, 9-blade airfoil cross section, reinforced polymer construction, and shrouded-axial type fans with inherent corrosion resistance.
 - b. Fans discharge air vertically upward and are protected by PVC coated steel wire safety guards.
 - c. Statically and dynamically balanced.
3. Fan Drive for SAV™ (Staged Air Volume) Units:
 Staged air volume units shall be equipped with variable frequency drive (VFD) inverter. The VFD shall control motor speed to user-configurable speeds. High speed shall be a percentage of 60 Hz, and shall be user configurable. The range of adjustment for high speed shall be between 50 and 100% of 60 Hz. Low speed shall be a percentage of 60 Hz, and shall be user configurable. The range of adjustment for low speed shall be between 33 and 67% of 60 Hz. The control shall allow user-configurable fan speeds for cooling and heating modes. The VFD shall be factory-mounted, wired, and tested. The variable speed drive shall include the following features.
- a. Full digital control with direct control from the unit *ComfortLink* controls.
 - b. Insulated gate bi-polar transistors (IGBT) used to produce the output pulse width modulated (PWM) waveform, allowing for quiet motor operation.
 - c. Inverters capable of operation at a frequency of 8 kHz so no acoustic noise shall be produced by the motor.
 - d. Critical frequency avoidance.
 - e. Self diagnostics.
 - f. On-board storage of unit manufacturer's customer user settings, retrievable from the keypad.
 - g. RS485 communications capability.
 - h. Electronic thermal overload protection.
 - i. 5% swinging chokes for harmonic reduction and improved power factor.
 - j. All printed circuit boards shall be conformal coated.
- k. Shall, through ABB, qualify for a 24-month warranty from date of commissioning or 30 months from date of sale, whichever comes first.
- D. Compressors:
- 1. Fully hermetic, scroll type compressors with overload protection and short cycle protection with minimum on and off timers.
 - 2. Factory rubber-in-shear mounted for vibration isolation.
 - 3. Reverse rotation protection capability.
 - 4. Crankcase heaters shall only be activated during compressor off mode.
- E. Coils:
- 1. Standard evaporator coil shall have aluminum plate fins mechanically bonded to seamless internally grooved copper tubes with all joints brazed.
 - 2. Standard condenser coil shall be microchannel design. The coil shall have a series of flat tubes containing a series of multiple, parallel flow microchannels layered between the refrigerant manifolds. Microchannel coils shall consist of a two-pass arrangement. Coil construction shall consist of aluminum alloys for the fins, tubes, and manifolds.
 - 3. Coils shall be leak tested at 150 psig and pressure tested at 650 psig.
 - 4. Optional condenser coil shall have aluminum plate fins mechanically bonded to seamless internally grooved copper tubes with all joints brazed.
 - 5. Optional pre-coated aluminum-fin coils shall have a durable epoxy-phenolic coating to provide protection in mildly corrosive coastal environments. Coating shall be applied to the aluminum fin stock prior to the fin stamping process to create an inert barrier between the aluminum fin and copper tube. Epoxy-phenolic barrier shall minimize galvanic action between dissimilar metals.
 - 6. Copper-fin coils shall be constructed of copper fins mechanically bonded to copper tubes and copper tube sheets. Galvanized steel tube sheets shall not be acceptable. A polymer strip shall prevent coil assembly from contacting the sheet metal coil pan to minimize potential for galvanic corrosion between coil and pan. All copper construction shall provide protection in moderate coastal environments.
 - 7. E-coated coils shall have a flexible epoxy polymer coating uniformly applied to all coil surface areas without material bridging between fins. Coating process shall ensure complete coil encapsulation. Color shall be high gloss black with gloss — 60 deg of 65 to 90% per ASTM D523-89. Uniform dry film thickness from 0.8 to 1.2 mil on all surface areas including fin

edges. Superior hardness characteristics of 2H per ASTM D3363-92A and cross-hatch adhesion of 4B-5B per ASTM D3359-93. Impact resistance shall be up to 160 in./lb (ASTM D2794-93). Humidity and water immersion resistance shall be up to minimum 1000 and 250 hours respectively (ASTM D2247-92 and ASTM D870-92). Corrosion durability shall be confirmed through testing to be no less than 6000 hours salt spray per ASTM B117-90. Coil construction shall be aluminum fins mechanically bonded to copper tubes.

F. Gas Heating Section (48 Series Only):

1. Induced-draft combustion type with energy-saving direct spark ignition systems and redundant main gas valves.
2. The heat exchanger shall be of the tubular section type constructed of a minimum of 20-gage steel coated with a nominal 1.2 mil aluminum-silicone alloy for corrosion resistance. Optional stainless steel heat exchangers shall be available.
3. Burners shall be of the in-shot type constructed of aluminum coated steel.
4. All gas piping shall enter the unit cabinet at a single location.
5. Induced Draft Fans:
 - a. Direct-driven, single inlet, forward-curved centrifugal type.
 - b. Statically and dynamically balanced.
 - c. Made from steel with a corrosion-resistant finish.
6. High-corrosion areas such as flue gas collection and exhaust areas shall be lined with corrosion resistant material.

G. Refrigerant Components:

Unit shall be equipped with dual refrigerant circuits, each containing:

1. Solid core filter drier.
2. Thermostatic expansion valve.
3. Fusible plug.

H. Filter Section:

Standard filter section shall be supplied with 2-in. thick disposable fiberglass filters.

I. Controls and Safeties:

1. Unit *ComfortLink* Controls:
 - a. Scrolling marquee display.
 - b. CCN (Carrier Comfort Network®) capable.
 - c. Unit control with standard suction pressure and condensing pressure transducers.
 - d. Shall provide a minimum 5° F temperature difference between cooling and heating set points to meet ASHRAE 90.1 energy standard.
 - e. Shall provide and display a current alarm list and an alarm history list.

- f. Automatic compressor lead/lag control.
- g. Service run test capability.
- h. Shall accept input from a CO₂ sensor (both indoor and outdoor).
- i. Configurable alarm light shall be provided which activates when certain types of alarms occur.
- j. Compressor minimum run time (3 minutes) and minimum off time (3 minutes) are provided.
- k. Service diagnostic mode.
- l. Optional integrated economizer control or two-position self-closing adjustable outside air damper.
- m. Minimum of 3 capacity stages of mechanical capacity control (excluding hot gas bypass) controlled by the following method:

A control algorithm to maintain either high-cool or low-cool supply air temperature set point. Cooling mode (off, low, or high) to be determined from space temperature sensor or standard 2-stage mechanical thermostat input.
- n. Optional minimum load valve for additional capacity stage.
- o. Unit shall be complete with self-contained low voltage control circuit.
- p. Control of evaporator leaving air temperature through compressor and economizer control.

2. Safeties:

- a. Unit shall incorporate a solid-state compressor lockout which provides optional reset capability at the space thermostat should any of the following safety devices trip and shut off compressor:
 - 1) Compressor lockout protection provided for either internal or external overload.
 - 2) Low-pressure protection.
 - 3) Freeze protection (evaporator coil).
 - 4) High-pressure protection (high pressure switch or internal).
 - 5) Compressor reverse rotation protection.
 - 6) Loss-of-charge protection.
 - 7) Welded contactor protection.
- b. Supply-air sensor shall be located in the unit and should be used for economizer control and compressor stage control.
- c. Induced draft heating section (48 Series) shall be provided with the following minimum protections:
 - 1) High-temperature limit switch.
 - 2) Induced-draft motor speed sensor.
 - 3) Flame rollout switch.
 - 4) Flame proving controls.
 - 5) Redundant gas valve.

J. Operating Characteristics:

1. Unit shall be capable of starting and running at 115 F ambient outdoor temperature per maximum load criteria of AHRI Standard 340/360.
2. Unit with standard controls will operate in cooling down to an outdoor ambient temperature of 32 F.
3. Unit shall be provided with fan time delay to help prevent cold air delivery.

K. Electrical Requirements:

All unit power wiring shall enter unit cabinet at a single location.

L. Motors:

1. Compressor motors shall be cooled by refrigerant gas passing through motor windings and shall have either internal line break thermal and current overload protection or external current overload modules with compressor temperature sensors.
2. All condenser-fan motors shall be totally enclosed 3-phase type with permanently lubricated ball bearings, class F insulation and internal, automatic-reset thermal overload protection or manual reset calibrated circuit breakers.
3. All indoor fan and power exhaust motors 5 hp and larger shall meet the minimum efficiency requirements as established by the Energy Independence and Security Act (EISA) of 2007.

M. Special Features:

Certain features are not applicable when the features designated * are specified. For assistance in amending the specifications, contact your local Carrier Sales Office.

1. Variable Capacity Compressor:

A variable capacity compressor shall be available for constant volume, staged air volume, and variable air volume configurations. The *ComfortLink* control system shall be capable of unloading this compressor in an infinite number of steps from 100% of compressor capacity down to 50% of compressor capacity.

2. Humidi-MiZer® Adaptive Dehumidification:

The Humidi-MiZer dehumidification system shall be factory installed with an e-coated reheat coil and shall provide greater dehumidification of the occupied space by using two modes of dehumidification instead of the normal design cooling mode of the unit:

- a. Subcooling mode shall further subcool the hot liquid refrigerant leaving the condenser coil when both temperature and humidity in the space are not satisfied.
- b. Hot gas reheat mode shall mix a portion of the hot gas from the discharge of the compressor with the hot liquid refrigerant leaving the condenser coil to create a two-phase

heat transfer in the system, resulting in a neutral leaving-air temperature.

- c. The system shall be equipped with modulating control valves to provide precise leaving-air temperature control. On-off, cycling type control shall not be acceptable.
- * 3. Integrated Ultra Low Leak Economizer:
 - a. Economizer shall meet the requirements of ASHRAE 90.1 (latest revision) and California Energy Commission Title 24.
 - b. Economizer shall be furnished and installed complete with recirculated air dampers, outdoor air dampers, and controls.
 - c. All dampers shall be ultra-low leakage type with blade and edge seals. Dampers shall be 1A certified and exhibit a maximum leakage rate of 3 cfm per square foot of area at 1 in. wg pressure differential when tested per AMCA (Air Movement and Control Association) Std 511.
 - d. Dampers shall continue to operate as intended after 100,000 cycles when tested in accordance with Section 8, UL (Underwriters Laboratories) standard 555S.
 - e. Actuator shall have a spring return feature which closes the outdoor air dampers upon a power interruption or unit shutdown. Actuators shall be of the communicating type and capable of internal diagnostics.
 - f. Economizer shall be capable of introducing up to 100% outdoor air for ventilation or free cooling.
 - g. Economizer outdoor air hoods shall be constructed of pre-painted steel.
- * 4. Barometric Relief Damper Package:
 - a. Package shall include damper, seals, hardware, and hoods to relieve excess internal pressure.
 - b. Damper shall close due to gravity upon unit shutdown.
- * 5. Power Exhaust:

Package shall include a multiple exhaust fan (centrifugal style) fan, 1 Hp 208-230, 460 v direct-drive motor, and damper for vertical flow units with economizer to control over-pressurization of building. Control shall be through *ComfortLink* controls based on damper position or through an optional building pressure sensor. On size 020-050 units, 4 stages of control shall be available. On size 060 units, 6 stages of control shall be available.
- * 6. Thermostats and Subbases:

To provide staged heating and cooling in addition to automatic (or manual) changeover and fan control.

- * 7. Electronic Programmable Thermostat:
Capable of using deluxe full-featured electronic thermostat.
- * 8. Liquefied Propane Conversion Kit (48 Series):
Kit shall contain all the necessary hardware and instructions to convert a standard natural gas unit for use with liquefied propane gas.
- * 9. Convenience Outlet:
Shall be factory installed and internally mounted with an externally accessible 115-v, 15 amp. GFI (Ground Fault Interrupter), female receptacle with hinged cover. A step-down transformer and overload protection shall be included so no additional wiring is necessary unless the field-wired outlet has been requested. When applied with a unit-mounted disconnect, the outlet shall be wired to the load side of the disconnect so the outlet will shut off with the disconnect.
- *10. Non-Fused Disconnect Switch:
Shall be factory installed, internally mounted, and UL approved. Non-fused switch shall provide unit power shutoff. Shall be accessible from outside the unit and shall provide power-off lockout capability.
- *11. Electric Heater (50 Series Units Only):
Electric resistance heaters shall be factory installed, nichrome element type, open wire coils with 0.29 in. inside diameter, insulated with ceramic bushings, and shall include operating and safety controls. Coil ends are staked and welded to terminal screw slots.
- *12. Hail Guard, Condenser Coil Grille:
Shall protect the condenser coil from hail, flying debris, and damage by large objects without increasing unit clearances.
- *13. CO₂ Sensor:
The CO₂ sensor shall have the ability to monitor CO₂ levels and relay information to the controller. The controller will use CO₂ level information to modulate the economizer and provide demand controlled ventilation. The sensor shall be available as a field-installed or factory-installed return air sensor or a remote space sensor.
- *14. Return Air Smoke Detector:
The smoke detector shall send input to the controller to shut down the unit in case smoke is detected. The smoke detector shall be factory installed in the return air section or shall be available as a field-installed accessory.
- *15. Filter Status:
The filter status switch shall be a pressure differential switch and will indicate a dirty filter. The switch shall be available as field or factory installed.
- *16. Humidity Sensor:
A humidity sensor will allow for outside air enthalpy changeover control using the standard outside air dry bulb sensor and the accessory humidity sensor. When both an outside and return air humidity sensor are used, differential enthalpy changeover can be supported.
- *17. Two-Position Damper:
A two-position damper shall admit up to 25% outdoor air during fan operation and shall close when the fan is off. The damper position shall be mechanically adjustable.
- *18. 4-Inch Filters:
Optional filter section shall be supplied with 4-in. thick MERV (Minimum Efficiency Reporting Value) 7 pleated fiberglass filters.
- *19. Control Expansion Module (CEM):
Shall provide the following additional optional features:
 - a. Remote set point
 - b. Demand limit control
 - c. Remote economizer position
 - d. Fire and smoke control override control
 - e. Remote sensor monitoring
 - f. Fan status switch monitoring
- *20. Staged Gas Heat (48A2,A4 only):
The control shall have the option for control of the gas heat to a discharge air temperature by sequencing on the gas cells to provide up to 11 stages of capacity. The control shall be integrated directly into the main unit controls and shall include leaving air temperature sensors to ensure that high temperatures do not occur during the operation of the staged gas heat.
- 21. Navigator™ Display Module:
The Navigator display module shall be a portable hand-held display module with a minimum of 4 lines and 20 characters per line, of clear English, Spanish, Portuguese, or French language. Display menus shall provide clear language descriptions of all menu items, operating modes, configuration points, and alarm diagnostics. Reference to factory codes shall not be accepted. An industrial grade coiled extension cord shall allow the display module to be moved around the chiller. Magnets shall hold the display module to any sheet metal panel to allow hands-free operation. Display module shall have NEMA (National Electrical Manufacturers Association) 4x housing suitable for use in outdoor environments. Display shall have back light and contrast adjustment for easy viewing in bright sunlight or night conditions. The display module shall have raised surface buttons with positive tactile response.

22. BACnet* Communication Option:
Shall provide factory-installed communication capability with a BACnet MS/TP network. Allows integration with i-Vu® Open Control System or a BACnet Building Automation System.
23. Modbus† Protocol Translator:
A controller-based accessory module shall provide CCN to MODBUS Remote Terminal Unit (RTU) protocol conversion.
24. LonWorks** Protocol Translator:
A controller-based accessory module shall provide CCN to LON FT-10A ANSI/EIA-709.1 protocol conversion.
25. Full Perimeter Roof Curbs (Horizontal and Vertical):
Shall be formed of 14-gage galvanized steel with wood nailer strip and shall be capable of supporting entire unit weight.
26. Security Grille (48/50A060 Unit with MCHX [microchannel heat exchanger] Only):
Factory-installed grille shall limit access to compressor and condenser coil area to authorized personnel only.
27. Double Wall Option:
Unit cabinet shall have double wall construction featuring flexible fire retardant fiberglass insulation sandwiched between pre-painted exterior panels and galvanized steel inner panels.
28. Low Outdoor Sound Accessory:
Field-installed accessory, consisting of compressor sound blankets which are used to mitigate the level of outdoor sound. Available in both single and tandem arrangements.
29. Low Outdoor Sound Condenser Fans:
Low sound condenser fan system shall be provided to reduce outdoor sound levels.
30. Low Ambient Control:
 - a. Control shall regulate outdoor fan motor speed in response to the saturated condensing temperature of the unit. The control shall be capable of operating the rooftop unit with outdoor temperatures at -20 F.
 - b. Motormaster® low ambient control shall be available as a factory-installed option.

* BACnet is a registered trademark of ASHRAE (American Society of Heating, Refrigerating, and Air-Conditioning Engineers).

† Modbus is a registered trademark of Schneider Electric.

** LonWorks is a registered trademark of Echelon Corporation.

Packaged Rooftop Cooling Unit and Packaged Rooftop Cooling Unit with Gas Heat — Variable Air Volume Application

HVAC Guide Specifications — Section 48/50A3,A5

Size Range: **20 to 60 Tons, Nominal (Cooling)**

Carrier Model Number:
48A3, 48A5, 50A3, 50A5

Part 1 — General

1.01 SYSTEM DESCRIPTION

Outdoor roof curb or slab mounted, electronically controlled heating and cooling unit utilizing hermetic scroll compressors with crankcase heaters for cooling duty and gas heat or electric heat. Units shall discharge supply and return air vertically or horizontally as shown on contract drawings. EERs (Energy Efficiency Ratios) shall meet requirements of ASHRAE (American Society of Heating, Refrigeration, and Air-Conditioning Engineers) Standard 90.1-2013.

1.02 QUALITY ASSURANCE

- A. Unit shall be rated in accordance with AHRI (Air-Conditioning, Heating, and Refrigeration Institute) Standard 340/360, latest edition.
- B. Unit shall be designed to conform to ANSI/ASHRAE 15 (latest edition), ASHRAE 62, and UL (Underwriters Laboratories) Standard 1995.
- C. Unit shall be listed by ETL and ETL, Canada as a total package.
- D. The 48A3,A5 units shall be designed to conform with ANSI (American National Standards Institute) Standard Z21.47 (U.S.A.) / CSA (Canadian Standards Association) Standard 2.3, Gas-Fired Central Furnaces.
- E. Roof curb shall be designed to NRCA (National Roofing Contractors Association) criteria per Bulletin B-1986.
- F. Insulation and adhesive shall meet NFPA (National Fire Protection Association) 90A requirements for flame spread and smoke generation.
- G. The management system governing the manufacture of this product is ISO (International Organization for Standardization) 9001:2008 certified.

1.03 DELIVERY, STORAGE AND HANDLING

Unit shall be stored and handled per manufacturer's recommendations.

Part 2 — Products

2.01 EQUIPMENT

A. General:

Factory-assembled, single-piece heating and cooling unit. Contained within the unit enclosure shall be all factory wiring, piping, refrigerant charge (R-410A), operating oil charge, dual refrigerant circuits, micro-processor-based control system and associated hardware, and all special features required prior to field start-up.

B. Unit Cabinet:

1. Constructed of galvanized steel, bonderized and precoated with a baked enamel finish.
 - a. Top cover shall be 18-gage sheet metal with 0.75-in. thick, 1.5-lb density, fiberglass insulation.
 - b. Access panels and doors shall be 20-gage sheet metal with 0.5-in. thick, 1.5-lb density, fiberglass insulation.
 - c. Corner and center posts shall be 16-gage galvanized steel.
 - d. Basepans in the heating and return air sections shall be 16-gage galvanized steel.
 - e. Basepans in the condenser section shall be 16-gage galvanized steel.
 - f. Compressor rail shall be 12-gage galvanized steel.
 - g. Condensate pan shall be 16-gage aluminized steel.
 - h. Air baffles shall be 18-gage galvanized steel with 0.5-in. thick, 1.5-lb density, fiberglass insulation.
 - i. Base rail shall be 14-gage galvanized steel.
 - j. Fan deck (indoor and outdoor section) shall be 16-gage galvanized steel.
2. Unit casing shall be capable of withstanding 500-hour salt spray exposure per ASTM (American Society for Testing and Materials) B117 (scribed specimen).
3. Sides shall have person-sized insulated hinged access doors for easy access to the control box and other areas requiring servicing. Each door shall seal against a rubber gasket to help prevent air and water leakage and be equipped to permit ease and safety during servicing.
4. Interior cabinet surfaces shall be sheet metal lined or insulated with flexible fire-retardant material, coated on the air side.
5. Unit shall have a factory-installed sloped condensate drain connection made from an aluminized steel or optional stainless steel.
6. Equipped with lifting lugs to facilitate overhead rigging.
7. Filters shall be accessible through a hinged access panel without requiring any special tools.

C. Fans:

1. Indoor Evaporator Fans:
 - a. Double-width/double-inlet, centrifugal, belt driven, forward-curved type with single outlet discharge.
 - b. Fan shaft bearings shall be of the pillow-block type with positive locking collar and lubrication provisions.
 - c. Statically and dynamically balanced.

- d. Evaporator fan shaft bearings shall have a life of 200,000 hours at design operating conditions in accordance with ANSI B3.15.
- e. Solid fan shaft construction for size 020-050 units and two-piece solid fan shaft construction on the size 060 unit.

2. Condenser Fans:

- a. Fans shall be direct-driven propeller type only, with corrosion-resistant blades riveted to corrosion-resistant steel supports for all size 020-050 units and the size 060 unit with optional condenser coil. Size 060 units with the microchannel condenser coil shall have a direct driven, 9-blade airfoil cross section, reinforced polymer construction, and shrouded-axial type fans with inherent corrosion resistance.
- b. Fans discharge air vertically upward and are protected by PVC coated steel wire safety guards.
- c. Statically and dynamically balanced.

3. Supply Fan Drive:

Unit shall be equipped with variable frequency drive (VFD) inverter. The VFD shall be installed inside the unit cabinet and shall be factory mounted, wired, and tested. The VFD shall control motor speed to maintain set point static pressure at the sensor tube location of the supply duct pressure transducer (transducer is factory provided and installed; sensor tube must be field routed). The control system may be field-adjusted to maintain supply duct static pressure set points from 0 in. wg to 3.5 in. wg.

The variable frequency drive shall include the following features:

- a. Full digital control with direct control from the unit *ComfortLink* controls.
- b. Insulated Gate Bi-Polar Transistors (IGBT) used to produce the output pulse width modulated (PWM) waveform, allowing for quiet motor operation.
- c. Inverters capable of operation at a frequency of 8 kHz, so no acoustic noise shall be produced by the motor.
- d. Self diagnostics.
- e. Personal lockout code for additional security.
- f. Critical frequency avoidance.
- g. RS485 capability standard.
- h. Electronic thermal overload protection.
- i. 5% swinging chokes for harmonic reduction and improved power factor.
- j. All printed circuit boards shall be conformal coated.
- k. Shall, through ABB, qualify for a 24-month warranty from date of commissioning or 30 months from date of sale, whichever comes first.

D. Compressors:

- 1. Fully hermetic, scroll type compressors with overload protection and short cycle protection with minimum on and off timers.
- 2. Factory rubber-in-shear mounted for vibration isolation.
- 3. Reverse rotation protection capability.
- 4. Crankcase heaters shall only be activated during compressor off mode.

E. Coils:

- 1. Standard evaporator coil shall have aluminum plate fins mechanically bonded to seamless internally grooved copper tubes with all joints brazed.
- 2. Standard condenser coil shall be microchannel design. The coil shall have a series of flat tubes containing a series of multiple, parallel flow microchannels layered between the refrigerant manifolds. Microchannel coils shall consist of a two-pass arrangement. Coil construction shall consist of aluminum alloys for the fins, tubes, and manifolds.
- 3. Coils shall be leak tested at 150 psig and pressure tested at 650 psig.
- 4. Optional condenser coil shall have aluminum plate fins mechanically bonded to seamless internally grooved copper tubes with all joints brazed.
- 5. Optional pre-coated aluminum-fin coils shall have a durable epoxy-phenolic coating to provide protection in mildly corrosive coastal environments. Coating shall be applied to the aluminum fin stock prior to the fin stamping process to create an inert barrier between the aluminum fin and copper tube. Epoxy-phenolic barrier shall minimize galvanic action between dissimilar metals.
- 6. Copper-fin coils shall be constructed of copper fins mechanically bonded to copper tubes and copper tube sheets. Galvanized steel tube sheets shall not be acceptable. A polymer strip shall prevent coil assembly from contacting the sheet metal coil pan to minimize potential for galvanic corrosion between coil and pan. All copper construction shall provide protection in moderate coastal environments.
- 7. E-coated coils shall have a flexible epoxy polymer coating uniformly applied to all coil surface areas without material bridging between fins. Coating process shall ensure complete coil encapsulation. Color shall be high gloss black with gloss—60 deg of 65 to 90% per ASTM D523-89. Uniform dry film thickness from 0.8 to 1.2 mil on all surface areas including fin edges. Superior hardness characteristics of 2H per ASTM D3363-92A and cross-hatch adhesion of 4B-5B per ASTM D3359-93. Impact resistance shall be up to 160 in./lb (ASTM D2794-93). Humidity and water immersion resistance shall be up to minimum 1000 and 250 hours respectively (ASTM D2247-92 and ASTM D870-92). Corrosion durability shall be confirmed through testing to be no less than

Guide specifications — 48/50A3,A5 (cont)



6000 hours salt spray per ASTM B117-90. Coil construction shall be aluminum fins mechanically bonded to copper tubes.

F. Gas Heating Section (48 Series Only):

1. Induced-draft combustion type with energy-saving direct spark ignition systems and redundant main gas valves.
2. The heat exchanger shall be of the tubular section type constructed of a minimum of 20-gage steel coated with a nominal 1.2 mil aluminum-silicone alloy for corrosion resistance. Optional stainless steel heat exchangers shall be available.
3. Burners shall be of the in-shot type constructed of aluminum coated steel.
4. All gas piping shall enter the unit cabinet at a single location.
5. Induced Draft Fans:
 - a. Direct-driven, single inlet, forward-curved centrifugal type.
 - b. Statically and dynamically balanced.
 - c. Made from steel with a corrosion-resistant finish.
6. High-corrosion areas such as flue gas collection and exhaust areas shall be lined with corrosion resistant material.

G. Refrigerant Components:

Unit shall be equipped with dual refrigerant circuits each containing:

1. Solid core filter drier.
2. Thermostatic expansion valve.
3. Fusible plug.

H. Filter Section:

Standard filter section shall be supplied with 2-in. thick disposable fiberglass filters.

I. Controls and Safeties:

1. Unit *ComfortLink* Controls:
 - a. Scrolling marquee display.
 - b. CCN (Carrier Comfort Network®) capable.
 - c. Unit control with standard suction pressure and condensing pressure transducers.
 - d. Shall provide a 5° F temperature difference between cooling and heating set points to meet ASHRAE 90.1, energy standard.
 - e. Shall provide and display a current alarm list and an alarm history list.
 - f. Automatic compressor redundancy.
 - g. Service run test capability.
 - h. Shall accept input from a CO₂ sensor (both indoor and outdoor).
 - i. Configurable alarm light shall be provided which activates when certain types of alarms occur.

j. Compressor minimum run time (3 minutes) and minimum off time (3 minutes) are provided.

k. Service diagnostic mode.

l. Optional integrated economizer control or two-position self-closing adjustable outside-air damper.

m. Minimum of 3 capacity stages of mechanical capacity control (excluding hot gas bypass) controlled with logic to maintain supply air temperature set point.

n. Optional minimum load valve for additional capacity stage.

o. Unit shall be complete with self-contained low voltage control circuit.

2. Safeties:

a. Unit shall incorporate a solid-state compressor lockout which provides optional reset capability at the space thermostat should any of the following safety devices trip and shut off compressor:

- 1) Compressor lockout protection provided for either internal or external overload.
- 2) Low-pressure protection.
- 3) Freeze protection (evaporator coil).
- 4) High-pressure protection (high pressure switch or internal).
- 5) Compressor reverse rotation protection.
- 6) Loss of charge protection.
- 7) Welded contactor protection.

b. Supply-air sensor shall be located in the unit and should be used for economizer control and compressor stage control.

c. Induced draft heating section (48 Series) shall be provided with the following minimum protections:

- 1) High-temperature limit switch.
- 2) Induced-draft motor speed sensor.
- 3) Flame rollout switch.
- 4) Flame proving controls.
- 5) Redundant gas valve.

J. Operating Characteristics:

1. Unit shall be capable of starting and running at 115 F ambient outdoor temperature per maximum load criteria of AHRI Standard 340/360.
2. Unit with standard controls will operate in cooling down to an outdoor ambient temperature of 32 F.
3. Unit shall be provided with fan time delay to prevent cold air delivery.

K. Electrical Requirements:

All unit power wiring shall enter unit cabinet at a single location.

L. Motors:

1. Compressor motors shall be cooled by refrigerant gas passing through motor windings and shall have either internal line break thermal and current overload protection or external current overload modules with compressor temperature sensors.
2. All condenser-fan motors shall be totally enclosed 3-phase type with permanently lubricated ball bearings, class F insulation and internal, automatic-reset thermal overload protection or manual reset calibrated circuit breakers.
3. All indoor fan and power exhaust motors 5 hp and larger shall meet the minimum efficiency requirements as established by the Energy Independence and Security Act (EISA) of 2007.

M. Special Features:

Certain features are not applicable when the features designated * are specified. For assistance in amending the specifications, contact your local Carrier Sales Office.

* 1. Variable Capacity Compressor:

A variable capacity compressor shall be available for constant volume, staged air volume, and variable air volume configurations. The *ComfortLink* control system shall be capable of unloading this compressor in an infinite number of steps from 100% of compressor capacity down to 50% of compressor capacity.

2. Humidi-MiZer[®] Adaptive Dehumidification:

The Humidi-MiZer dehumidification system shall be factory installed with an e-coated reheat coil and shall provide greater dehumidification of the occupied space by using two modes of dehumidification instead of the normal design cooling mode of the unit:

- a. Subcooling mode shall further subcool the hot liquid refrigerant leaving the condenser coil when both temperature and humidity in the space are not satisfied.
- b. Hot gas reheat mode shall mix a portion of the hot gas from the discharge of the compressor with the hot liquid refrigerant leaving the condenser coil to create a two-phase heat transfer in the system, resulting in a neutral leaving-air temperature.
- c. The system shall be equipped with modulating control valves to provide precise leaving air temperature control. On-off, cycling type control shall not be acceptable.

* 3. Ultra Low Leak Economizer:

Dry bulb, differential dry bulb temperature, optional enthalpy, or optional differential enthalpy controlled integrated type consisting of dampers, actuator, and linkages in conjunction with control system to provide primary cooling using outdoor air, conditions permitting, supplemented with mechanical cooling when necessary.

- a. Economizer shall meet the requirements of the California Energy Commission Title 24 economizer requirements.
- b. Dampers shall be a gear-driven ultra low leakage type with blade and edge seals. Dampers shall exhibit a maximum leakage rate of 3 cfm per square foot of area at 1 in. wg pressure differential when tested in accordance with AMCA (Air Movement and Control Association) Standard 500.

* 4. Barometric Relief Damper Package:

- a. Package shall include damper, seals, hardware, and hoods to relieve excess internal pressure.
- b. Damper shall close due to gravity upon unit shutdown.

* 5. Power Exhaust:

Package shall include a multiple exhaust fan (centrifugal style) fan, 1 Hp 208-230, 460 v direct-drive motor, and damper for vertical flow units with economizer to control over-pressurization of building. Control shall be through *ComfortLink* controls based on optional building pressure sensor. On size 020-050 units, 4 stages of control shall be available. On size 060 units, 6 stages of control shall be available.

* 6. Liquefied Propane Conversion Kit (48 Series):

Kit shall contain all the necessary hardware and instructions to convert a standard natural gas unit for use with liquefied propane gas.

* 7. Convenience Outlet:

Shall be factory installed and internally mounted with an externally accessible 115-v, 15 amp GFI (ground fault interrupter), female receptacle with hinged cover. A step-down transformer and overload protection shall be included so no additional wiring is necessary unless the field-wired outlet has been requested. When applied with a unit-mounted disconnect, the outlet shall be wired to the load side of the disconnect so the outlet will shut off with the disconnect.

* 8. Non-Fused Disconnect Switch:

Shall be factory installed, internally mounted, and UL approved. Non-fused switch shall provide unit power shutoff. Shall be accessible from outside the unit and shall provide power off lockout capability.

* 9. Electric Heater (50 Series Units Only):

Electric resistance heaters shall be factory-installed, nichrome element type, open wire coils with 0.29 in. inside diameter, insulated with ceramic bushings, and include operating and safety controls. Coil ends are staked and welded to terminal screw slots.

*10. Hail Guard, Condenser Coil Grille:

Shall protect the condenser coil from hail, flying debris, and damage by large objects without increasing unit clearances.

- *11. CO₂ Sensor:
The CO₂ sensor shall have the ability to monitor CO₂ levels and relay information to the controller. The controller will use CO₂ level information to modulate the economizer and provide demand controlled ventilation. The sensor shall be available as a field-installed or factory-installed return air sensor or a remote space sensor.
- *12. Return Air Smoke Detector:
The smoke detector shall send input to the controller to shut down the unit in case smoke is detected. The smoke detector shall be factory installed in the return air section or shall be available as a field-installed accessory.
- *13. Filter Status:
The filter status switch shall be a pressure differential switch and will indicate a dirty filter. The switch shall be available as field or factory installed.
- *14. Humidity Sensor:
A humidity sensor will allow for outside air enthalpy changeover control using the standard outside air dry bulb sensor and the accessory humidity sensor. When both an outside and return air humidity sensor are used, differential enthalpy changeover can be supported.
- *15. Two-Position Damper:
A two-position damper shall admit up to 25% outdoor air during fan operation and shall close when the fan is off. The damper position shall be mechanically adjustable.
- *16. 4-Inch Filters:
Optional filter section shall be supplied with 4-in. thick MERV (Minimum Efficiency Reporting Value) 7 pleated fiberglass filters.
- *17. Control Expansion Module (CEM):
Shall provide the following additional optional features:
 - a. Remote set point.
 - b. Demand limit control.
 - c. Remote economizer position.
 - d. Fire and smoke control override control.
 - e. Remote sensor monitoring.
 - f. Fan status switch monitoring.
- 18. Bypass for Supply Fan VFD (Variable Frequency Drive):
Units may be equipped with an optional manual bypass switch which allows the supply fan VFD to be electrically bypassed.
- 19. BACnet* Communication Option:
Shall provide factory-installed communication capability with a BACnet MS/TP network. Allows integration with i-Vu® Open Control System or a BACnet Building Automation System.
- 20. Modbus† Protocol Translator:
A controller-based module shall provide CCN to MODBUS Remote Terminal Unit (RTU) protocol conversion.
- 21. LonWorks** Protocol Translator:
A controller-based module shall provide CCN to LON FT-10A ANSI/EIA-709.1 protocol conversion.
- 22. Navigator™ Display Module:
The Navigator display module shall be a portable hand-held display module with a minimum of 4 lines and 20 characters per line, of clear English, Spanish, Portuguese, or French language. Display menus shall provide clear language descriptions of all menu items, operating modes, configuration points and alarm diagnostics. Reference to factory codes shall not be accepted. An industrial grade coiled extension cord shall allow the display module to be moved around the chiller. Magnets shall hold the display module to any sheet metal panel to allow hands-free operation. Display module shall have NEMA (National Electrical Manufacturers Association) 4x housing suitable for use in outdoor environments. Display shall have back light and contrast adjustment for easy viewing in bright sunlight or night conditions. The display module shall have raised surface buttons with positive tactile response.
- *23. Staged Gas Heat (48A3,A5 only):
The control shall have the option for control of the gas heat to a discharge air temperature by sequencing on the gas cells to provide up to 11 stages of capacity. The control shall be integrated directly into the main unit controls and shall include leaving air temperature sensors to ensure that high temperatures do not occur during the operation of the staged gas heat.
- 24. Full Perimeter Roof Curbs (Horizontal and Vertical):
Shall be formed of 14-gage galvanized steel with wood nailer strip and shall be capable of supporting entire unit weight.
- 25. Security Grille (48/50A060 Unit with MCHX [microchannel heat exchanger] Only):
Factory-installed grille shall limit access to compressor and condenser coil area to authorized personnel only.
- 26. Double Wall Option:
Unit cabinet shall have double wall construction featuring flexible fire retardant fiberglass insulation sandwiched between pre-painted exterior panels and galvanized steel inner panels.

* BACnet is a registered trademark of ASHRAE (American Society of Heating, Refrigerating, and Air-Conditioning Engineers).

† Modbus is a registered trademark of Schneider Electric.

** LonWorks is a registered trademark of Echelon Corporation.

27. Low Outdoor Sound Accessory:

Field-installed accessory, consisting of compressor sound blankets which are used to mitigate the level of outdoor sound. Available in both single and tandem arrangements.

28. Low Outdoor Sound Condenser Fans:

Low sound condenser fan system shall be provided to reduce outdoor sound levels.

29. Low Ambient Control:

- a. Control shall regulate outdoor fan motor speed in response to the saturated condensing temperature of the unit. The control shall be capable of operating the rooftop unit with outdoor temperatures at -20 F.
- b. Motormaster® low ambient control shall be available as a factory-installed option.

