

**48TC
Gas Heat/Electric Cooling
Packaged Rooftop
3 to 15 Nominal Tons**

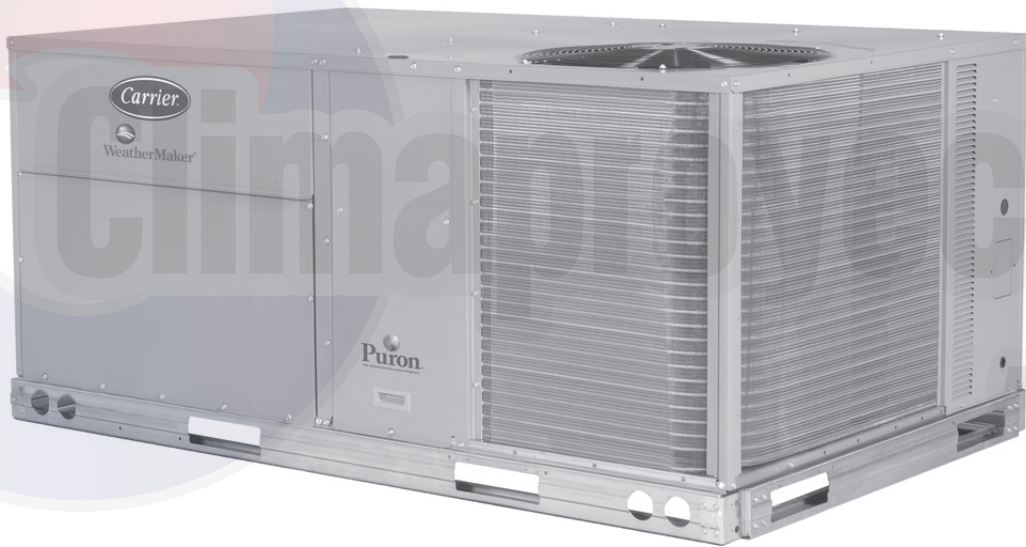

Product Data



C08613



TABLE OF CONTENTS

	PAGE		PAGE
FEATURES AND BENEFITS	3	APPLICATION DATA	31
MODEL NUMBER NOMENCLATURE	4	COOLING TABLES	34
FACTORY OPTIONS AND/OR ACCESSORIES	6	STATIC PRESSURE ADDERS	55
AHRI COOLING RATING TABLES	9	FAN PERFORMANCE	59
HEAT RATING TABLE	10	ELECTRICAL INFORMATION	72
SOUND PERFORMANCE TABLE	11	SEQUENCE OF OPERATION	102
PHYSICAL DATA	13	GUIDE SPECIFICATIONS	105
CURBS & WEIGHTS DIMENSIONS	19		



Turn to the Experts™

The Carrier rooftop unit (RTU) was designed by customers for customers. With “no-strip screw” collars, handled access panels, and more we’ve made your unit easy to install, easy to maintain and easy to use.

Easy to install:

All WeatherMaker® units are field-convertible to horizontal air flow which makes it easy to adjust to unexpected job site complications. Lighter units make easy replacement. Most Carrier 48TC rooftops fit on existing Carrier curbs dating back to 1989. Also, our large control box gives you room to work and room to mount Carrier accessory controls.

Easy to maintain:

Easy access handles by Carrier provide quick and easy access to all normally serviced components. Our “no-strip” screw system has superior holding power and guides screws into position while preventing the screw from stripping the unit’s metal. Take accurate pressure readings by reading condenser pressure with panels on. Simply remove the black, composite plug, route your gauge line(s) through the hole, and connect them to the refrigeration service valve(s).

Easy to use:

The newly designed, central terminal board by Carrier puts all your connections and troubleshooting points in one convenient place, standard. Most low voltage connections are made to the same board and make it easy to find what you’re looking for and easy to access it. Carrier rooftops have high and low pressure switches, a filter drier, and 2-in (51mm) filters standard.

FEATURES AND BENEFITS

- Single cooling stage models are available from 3 - 10 ton.
- Two cooling stage models are available from 7.5 - 15 ton.
- SEER up to 13.0.
- EER's up to 11.1.
- IEER's up to 11.8 with single speed indoor fan motor and up to 12.8 with 2-speed/VFD indoor fan motor.
- Up to 28% lighter than similar industry units. Lighter rooftops make easier replacement jobs.
- Utility connections are the same because 3 - 12.5 ton units fit on existing Carrier rooftop curbs. This saves time and money on replacement jobs.
- Standardized components and layout. Standardized components and controls make service and stocking parts easier.
- Scroll compressors on all units. This makes service, stocking parts, replacement, and troubleshooting easier.
- Field convertible airflow (3 - 15 ton). Being able to convert a unit from vertical airflow to horizontal makes it easy to overcome job site complications. 15 ton models require a simple supply duct cover to field convert from factory vertical to horizontal.
- Easy-adjust, belt-drive motor available.
- Provisions for bottom or side condensate drain.
- Capable of thru-the-base or thru-the-curb gas line routing.
- Single-point gas / electrical connection.
- Sloped, composite drain pan sheds water; and won't rust.
- Standardized controls & control box layout. Standardized components & controls make stocking parts & service easier.
- Tool-less filter access door.
- Clean, large, easy to use control box.
- Color-coded wiring.
- Large, laminated wiring and power wiring drawings which are affixed to unit make troubleshooting easy.
- Single, central terminal board for test and wiring connections.
- Fast-access, handled, panels for easy access on normally accessed service panels.
- "No-strip" screw system guides screws into the panel & captures them tightly without stripping the screw, the panel, or the unit.
- Mechanical cooling (115°F to 40°F or 46°C to 4°C) standard on all models. Winter Start Kit allows cooling operation down to 25°F (-4°C) and MotorMaster to -20°F (-29°C).
- High efficiency, gas heat with induced-draft flue exhaust design.
- Induced draft motor ensures no flue gas can escape into the indoor air stream.
- Carrier designed naturally draining heat exchanger, unlike positive pressure heat exchangers, do not need to be periodically, manually drained. This saves labor and maintenance expense.
- 2-in (51mm) disposable filters on all units.
- Refrigerant filter-drier on each circuit.
- Each circuit is protected with a high and low pressure switch.
- Many factory-installed options ranging from air management economizers, 2 position dampers, plus convenience outlets, disconnect switches and smoke detectors.
- Standard (parts only) Warranty: 10 yr. aluminized heat exchanger, 5 yr. compressor, 3 yr. Novation condenser coil, 1 yr. parts.
- Factory-installed Humidi-MiZer® adaptive dehumidification system on all sizes with round tube / plate fin condenser coils, includes MotorMaster I controller.
- Optional Staged Air Volume (SAV) system utilizes a Variable Frequency Drive (VFD) to automatically adjust the indoor fan motor speed between cooling stages. Available on 2-stage cooling models 08-16 with electromechanical controls or RTU Open.

MODEL NUMBER NOMENCLATURE

4 8 T C D A 0 4 A 1 A 5 - 0 A 0 A 0

Unit Heat Type

48 = Gas heat pkg. rooftop

Series Model

TC = Standard Efficiency

Heat Size

D = Low heat
 E = Med heat
 F = High heat
 L = Low NOx, Low heat
 M = Low NOx, Med heat
 N = Low NOx, High heat
 S = Stainless steel, Low heat
 R = Stainless steel, Med heat
 T = Stainless steel, High heat

Refrigerant Systems Options

A = Standard 1 stage cooling models
 B = Standard 1 stg. Cooling w/Humidi-MiZer (04-07 models only)
 D = 2 stage cooling models (08-16 models only)
 E = 2 stage cooling models w/ AI-CU cond coil & Humidi-MiZer (08-16 models only)

Cooling Tons

04 = 3 Ton 09 = 8.5 Ton
 05 = 4 Ton 12 = 10 Ton
 06 = 5 Ton 14 = 12.5 Ton
 07 = 6 Ton 16 = 15 Ton
 08 = 7.5 Ton

Sensor Options

A = None
 B = RA smoke detector
 C = SA smoke Detector
 D = RA + SA smoke detector
 E = CO2 sensor
 F = RA smoke detector & CO2 sensor
 G = SA smoke detector & CO2 sensor
 H = RA + SA smoke detector & CO2 sensor

Indoor Fan Options

1 = Standard static option
 2 = Medium static option
 3 = High static option
 C = High Static option w/high efficiency motor (size 16 only)

Note: On single phase (-3 voltage code) models, the following are not available as a factory installed option:

- Humidi-MiZer
- Coated Coils or Cu Fin Coils
- Louvered Hail Guards
- Economizer or 2 Position Damper
- Powered 115 Volt Convenience Outlet

Packaging & Seismic

0 = Standard
 1 = LTL
 3 = CA seismic compliant
 4 = LTL & CA seismic compliant

Electrical Options

A = None
 C = Non-fused disconnect
 D = Thru the base conn
 F = Non fused disc & thru the base
 G = 2 speed indoor fan (VFD) contr
 J = 2 speed fan cntr (VFD) & non fused disc
 K = 2 spd fan cntr (VFD) & thru the base conn
 M = 2 speed fan (VFD) & non fused disc & thru the base conn

Service Options

0 = None
 1 = Unpowered convenience outlet
 2 = Powered convenience outlet
 3 = Hinged panels
 4 = Hinged panels, unpowered C.O.
 5 = Hinged panels, powered C.O

Intake / Exhaust Options

A = None
 B = Temp Economizer w/ barometric relief
 F = Enthalpy Econo w/ baro relief
 K = 2 position damper
 U = Temp ultra low leak econo w/baro relief
 W = Enthalpy ultra low leak econo w/baro relief

Base unit controls

0 = Base electromechanical controls
 1 = PremierLink Controller
 2 = RTU open multi-protocol controller
 6 = Electromechanical with 2 speed fan & W7720 econo cntl.

Design Revision

Factory Assigned

Voltage

1 = 575/3/60 5 = 208-230/3/60
 3 = 208-230/1/60 6 = 460/3/60

Coil Options for Round Tube/Plate Fin Cond Coil Models Only

(outdoor-indoor-hailguard)

A = Al/Cu - Al/Cu	M = Al/Cu - Al/Cu - Louvered hail guard
B = Precoat Al/Cu - Al/Cu	N = Precoat Al/Cu - Al/Cu - Louvered hail guard
C = Ecoat Al/Cu - Al/Cu	P = Ecoat Al/Cu - Al/Cu - Louvered hail guard
D = Ecoat Al/Cu Ecoat Al/Cu	Q = Ecoat Al/Cu - Ecoat Al/Cu louvered hail guard
E = Cu/Cu - Al/Cu	R = Cu/Cu - Al/Cu - Louvered hail guard
F = Cu/Cu - Cu/Cu	S = Cu/Cu - Cu/Cu - Louvered hail guard

Coil Options for All Aluminum Novation Cond Coil Models Only

(outdoor-indoor-hailguard)

G = Al/Al - Al/Cu	T = Al/Al - Al/Cu, louvered hail guard
H = Al/Al - Cu/Cu	U = Al/Al - Al/Cu, louvered hail guard
J = Al/Al - Ecoat Al/Cu	V = Al/Al - Ecoat Al/Cu, louvered hail guard
K = Ecoat Al/Al - Al/Cu	W = Ecoat Al/Al - Al/Cu, louvered hail guard
L = Ecoat Al/Al - Ecoat Al/Cu	X = Ecoat Al/Al - Ecoat Al/Cu louvered hail guard

Not all possible options can be displayed above - see price pages or contact your Carrier Expert for more details.

Table 1 – FACTORY-INSTALLED OPTIONS AND FIELD-INSTALLED ACCESSORIES

CATEGORY	ITEM	FACTORY INSTALLED OPTION	FIELD INSTALLED ACCESSORY
Cabinet	Thru-the-base electrical or gas-line connections	X	X
	Supply Duct Cover (16 size only)		X
	California Seismic Compliant Labeling	X	
	Hinged Access Panels	X	
Coil Options	Cu/Cu indoor and/or outdoor coils ^{1, 6}	X	
	Pre-coated outdoor coils ^{1, 6}	X	
	Premium, E-coated outdoor coils ^{1, 6}	X	
Humidity Control	Humidi-MiZer Adaptive Dehumidification System ⁶	X	
Condenser Protection	Condenser coil hail guard (louvered design) ⁶	X	X
Controls	Thermostats, temperature sensors, and subbases		X
	PremierLink DDC communicating controller	X	X
	RTU Open-protocol controller	X	
	Smoke detector (supply and/or return air)	X	
	Time Guard II compressor delay control circuit		X
	Phase Monitor		X
Economizers & Outdoor Air Dampers	EconoMi\$er™ IV (for electro-mechanical controlled RTUs) ⁶	X	X
	EconoMi\$er™ 2 (for DDC controlled RTUs) ⁶	X	X
	Motorized 2 position outdoor air damper ⁶	X	X
	Manual outdoor air damper (25% and 50%)		X
	Barometric relief ²	X	X
	Power exhaust		X
	Ultra Low Leak EconoMi\$er X (for 2-speed SAV system only 08 to 16 sizes with 2 stages of cooling), vertical supply and return air only.	X	X
Economizer Sensors & IAQ Devices	Single dry bulb temperature sensors ³	X	X
	Differential dry bulb temperature sensors ³		X
	Single enthalpy sensors ³	X	X
	Differential enthalpy sensors ³		X
	Wall or duct mounted CO ₂ sensor ³		X
	Unit mounted CO ₂ sensor ³	X	
Gas Heat	Propane conversion kit		X
	Stainless steel heat exchanger	X	
	High altitude conversion kit		X
	Flue Shield (04-14 sizes only)		X
	Flue Discharge Deflector (04-14 sizes only)		X
Indoor Motor & Drive	Multiple motor and drive packages	X	
	Staged Air Vol (SAV) system w/VFD controller (2-stage cool only with electrical mechanical and RTU Open controls)	X	
	Display Kit for SAV system with VFD		X
Low Ambient Control	Winter start kit ⁴		X
	Motormaster® head pressure controller ⁴		X
Power Options	Convenience outlet (powered) ⁶	X	
	Convenience outlet (un-powered)	X	
	Non-fused disconnect ⁵	X	
	Disconnect Switch Bracket (16 size only)		X
Roof Curbs	Roof curb 14-in (356mm)		X
	Roof curb 24-in (610mm)		X

NOTES:

1. Novation coated coils only available with E-coat.
2. Included with economizer.
3. Sensors used to optimize economizer performance.
4. See application data for assistance.
5. Available on units with MOCP's of 80 amps or less.
6. Not available as factory installed option on single phase (208/230/1/60) models. Use field-installed accessory where available.

FACTORY OPTIONS AND/OR ACCESSORIES

Economizer (dry-bulb or enthalpy)

Economizers save money. They bring in fresh, outside air for ventilation; and provide cool, outside air to cool your building. This is the preferred method of low ambient cooling. When coupled to CO₂ sensors, economizers can provide even more savings by coupling the ventilation air to only that amount required.

Economizers are available, installed and tested by the factory, with either enthalpy or dry-bulb temperature inputs. There are also models for electromechanical as well as direct digital controllers. Additional sensors are available as accessories to optimize the economizers.

Economizers include gravity controlled, barometric relief which equalizes building pressure and ambient air pressures. This can be a cost effective solution to prevent building pressurization.

CO₂ Sensor

Improves productivity and saves money by working with the economizer to intake only the correct amount of outside air for ventilation. As occupants fill your building, the CO₂ sensor detects their presence through increasing CO₂ levels, and opens the economizer appropriately.

When the occupants leave, the CO₂ levels decrease, and the sensor appropriately closes the economizer. This intelligent control of the ventilation air, called Demand Control Ventilation (DCV) reduces the overall load on the rooftop, saving money.

Smoke Detectors

Trust the experts. Smoke detectors make your application safer and your job easier. Carrier smoke detectors immediately shut down the rooftop unit when smoke is detected. They are available, installed by the factory, for supply air, return air, or both.

Louvered Hail Guards

Sleek, louvered panels protect the condenser coil from hail damage, foreign objects, and incidental contact.

Convenience Outlet (powered or un-powered)

Reduce service and/or installation costs by including a convenience outlet in your specification. Carrier will install this service feature at our factory. Provides a convenient, 15 amp, 115v GFCI receptacle with "Wet in Use" cover. The "powered" option allows the installer to power the outlet from the line side of the disconnect or load side as required by code. The "un-powered" option is to be powered from a separate 115/120v power source.

Non-fused Disconnect

This OSHA-compliant, factory installed, safety switch allows a service technician to locally secure power to the rooftop.

Disconnect Switch Bracket

Provides a pre-engineered and sized mounting bracket for applications requiring a unit mounted fused and non-fused disconnect of greater than 100 amps. Bracket assures that no damage will occur to coils when mounting with screws and other fasteners (16 size only).

Power Exhaust with Barometric Relief

Superior internal building pressure control. This field installed accessory may eliminate the need for costly, external pressure control fans.

PremierLink, DDC Controller

This CCN controller regulates your rooftop's performance to tighter tolerances and expanded limits, as well as facilitates zoning systems and digital accessories. It also unites your Carrier HVAC equipment together on one, coherent CCN network. The PremierLink can be factory installed, or easily field installed. Not available with 2-speed Staged Air Volume (SAV) system.

RTU Open, Multi-Protocol Controller

Connect the rooftop to an existing BAS without needing complicated translators or adapter modules using the RTU Open controller. This new controller speaks the 4 most common building automation system languages (Bacnet, Modbus, N2, and Lonworks). Use this controller when you have an existing BAS.

Time Guard II Control Circuit

This accessory protects your compressor by preventing short-cycling in the event of some other failure, prevents the compressor from restarting for 30 seconds after stopping. Not required with PremierLink, RTU Open, or authorized commercial thermostats.

Motorized 2-Position Damper

The new Carrier 2-position, motorized outdoor air damper admits up to 100% outside air. Using reliable, gear-driven technology, the 2-position damper opens to allow ventilation air and closes when the rooftop stops, stopping unwanted infiltration.

Manual OA Damper

Manual outdoor air dampers are an economical way to bring in ventilation air. The dampers are available in 25% and 50% versions.

Optional Humidi-MiZer Adaptive Dehumidification System

Carrier's Humidi-MiZer Adaptive Dehumidification System is an all-inclusive factory installed option that can be ordered with any WeatherMaker 48TC**04-16 rooftop unit.

FACTORY OPTIONS AND/OR ACCESSORIES (cont.)

Opt. Humidi-MiZer Adap. Dehum. Sys. (cont.)

This system expands the envelope of operation of Carrier's WeatherMaker rooftop products to provide unprecedented flexibility to meet year round comfort conditions.

The Humidi-MiZer adaptive dehumidification system has the industry's only dual dehumidification mode setting. The Humidi-MiZer system includes two new modes of operation.

The WeatherMaker 48TC**04-16 rooftop coupled with the Humidi-MiZer system is capable of operating in normal design cooling mode, subcooling mode, and hot gas reheat mode. Normal design cooling mode is when the unit will operate under its normal sequence of operation by cycling compressors to maintain comfort conditions.

Subcooling mode will operate to satisfy part load type conditions when the space requires combined sensible and a higher proportion of latent load control. Hot Gas Reheat mode will operate when outdoor temperatures diminish and the need for latent capacity is required for sole humidity control. Hot Gas Reheat mode will provide neutral air for maximum dehumidification operation.

Staged Air Volume (SAV) Indoor Fan Speed System

Carrier's Staged Air Volume (SAV) system saves energy and installation time by utilizing a Variable Frequency Drive (VFD) to automatically adjust the indoor fan motor speed in sequence with the units cooling operation. Per ASHRAE 90.1 2010 standard section 6.4.3.10.b, during the first stage of cooling operation the VFD will adjust the fan motor to provide 2/3rd of the total cfm established for the unit. When a call for the second stage of cooling is required, the VFD will allow the total cfm for the unit established (100%). During the heating mode the VFD will allow total design cfm (100%) operation and during the ventilation mode the VFD will allow operation to 2/3rd of total cfm.

Compared to single speed indoor fan motor systems, Carrier's SAV system can save substantial energy, 25%+*, versus single speed indoor fan motor systems.

The VFD used in Carrier's SAV system has soft start capabilities to slowly ramp up the speeds, thus eliminating any high inrush air volume during initial start-up. It also has internal over-current protection for the fan motor and a field installed display kit that allows adjustment and in depth diagnostics of the VFD.

This SAV system is available on models with 2-stage cooling operation with electromechanical or RTU Open, Multi Protocol controls. Both space sensor and conventional thermostats/controls can be used to provide accurate control in any application.

The SAV system is very flexible for initial fan performance set up and adjustment. The standard factory shipped VFD is pre-programmed to automatically stage the fan speed between the first and second stage of cooling. The unit fan performance static pressure and cfm can be easily adjusted using the traditional means of pulley adjustments. The other means to adjust the unit static and cfm performance is to utilize the field installed Display Kit and adjust the frequency and voltage in the VFD to performance requirements. In either case, once set up, the VFD will automatically adjust the speed between the cooling stage operations.

*Data based on .10 (\$/kWh) in an office application utilizing Carrier's HAP 4.6 simulation software program

Motormaster Head Pressure Controller

The Motormaster motor controller is a low ambient, head pressure controller kit that is designed to maintain the unit's condenser head pressure during periods of low ambient cooling operation. This device should be used as an alternative to economizer free cooling when economizer usage is either not appropriate or desired. The Motormaster will either cycle the outdoor fan motors or operate them at reduced speed to maintain the unit operation, depending on the model.

Winter Start Kit

The winter start kit by Carrier extends the low ambient limit of your rooftop to 25°F (-4°C). The kit bypasses the low pressure switch, preventing nuisance tripping of the low pressure switch. Other low ambient precautions may still be prudent.

Propane Heating

Convert your gas heat rooftop from standard natural gas operation to propane using this field installed kit.

High Altitude Heating

High altitudes have less oxygen, which means heat exchangers need less fuel. The new gas orifices in this field installed kit make the necessary adjustment for high altitude applications. They restore the optimal fuel to air mixture and maintain healthy combustion at altitudes above 2000 ft (610m). Kits may not be required in all areas.

Hinged Access Panels

Allows access to unit's major components with specifically designed hinged access panels. Panels are: filter, control box, fan motor, and compressor.

FACTORY OPTIONS AND/OR ACCESSORIES (cont.)

Flue Discharge Deflector

The flue discharge deflector is a useful accessory when flue gas recirculation is a concern. By venting the flue discharge upwards, the deflector minimizes the chance for a neighboring unit to intake the flue exhaust (04-14 sizes only).

Optional Stainless Steel Heat Exchanger

The stainless steel heat exchanger option provides the tubular heat exchanger be made out of a minimum 20 gauge type 409 stainless steel for applications where the mixed air to the heat exchanger is expected to drop below 45°F (7°C). Stainless steel may be specified on applications where the presence of airborne contaminants require its use (applications such as paper mills) or in areas with very high outdoor humidity that may result in severe condensation in the heat exchanger during cooling operation.

Flue Discharge Heat Shield

The flue discharge heat shield keeps people from touching the rooftop unit's potentially hot flue discharge. This is especially useful for ground level applications, where more, untrained people could have access to the unit's exterior (04-14 sizes only).

Alternate Motors and Drives

Some applications need larger horsepower motors, some need more airflow, and some need both. Regardless of the case, your Carrier expert has a factory installed combination to meet your application. A wide selection of motors and pulleys (drives) are available, factory installed, to handle nearly any application.

Thru-the-Base Connections

Thru-the-base connections, available as either an accessory or as a factory option, are necessary to ensure proper connection and seal when routing wire and piping through the rooftop's basepan and curb. These couplings eliminate roof penetration and should be considered for gas lines, main power lines, as well as control power.

Supply Duct Cover

This supply duct cover is required when field converting the factory standard vertical duct supply to horizontal duct supply configuration. One required per unit (16 size only).

California OSHPD Seismic Certification Label

Units meet the seismic requirements of the International Code Council Evaluation Service (ICC-ES) document AC156 (Acceptance Criteria for Seismic Qualification by Shake-Table Testing of Nonstructural Components and Systems) and per International Building Code (IBC 2009) at an SDS (g) value of 2.00 z/h=1.0, Ip=1.5 and certified by independent structural engineers. A certification label is applied to the unit that meets the CA OSHPD Special Seismic Certification pre-approval labeling requirements on the external chassis of the unit.

Table 2 – AHRI COOLING RATING TABLE

UNIT	COOLING STAGES	NOM. CAPACITY (TONS)	NET COOLING CAPACITY (MBH)	TOTAL POWER (KW)	SEER	EER	IEER
A04	1	3	34.6	3.1	13.0	11.00	N/A
A05	1	4	45.0	4.0	13.0	11.00	N/A
A06	1	5	59.0	5.5	13.0	10.75	N/A
A07	1	6	70.0	6.4	N/A	11.00	11.2
A08	1	7.5	88.0	8.0	N/A	11.00	11.2
A09	1	8.5	97.0	8.8	N/A	11.00	11.2
A12	1	10	117.0	10.6	N/A	11.00	11.2

UNIT	COOLING STAGES	NOM. CAPACITY (TONS)	NET COOLING CAPACITY (MBH)	TOTAL POWER (KW)	EER	IEER WITH SINGLE SPEED INDOOR FAN MOTOR	IEER WITH 2 SPEED INDOOR FAN MOTOR
D08	2	7.5	83.0	7.5	11.00	11.7	12.8
D09	2	8.5	97.0	9.0	11.00	11.2	12.8
D12	2	10	114.0	10.3	11.10	11.8	12.8
D14	2	12.5	140.0	12.9	10.80	11.0	11.8
D16	2	15	174.0	16.1	10.80	11.7	12.4

LEGEND

- AHRI – Air Conditioning, Heating and Refrigeration Institute Test Standard
- ASHRAE – American Society of Heating, Refrigerating and Air Conditioning, Inc.
- EER – Energy Efficiency Ratio
- IEER – Integrated Energy Efficiency Ratio
- N/A – Not Applicable
- SEER – Seasonal Energy Efficiency Ratio

NOTES:

1. Rated in accordance with AHRI Standard 210/240 or 340/360, as appropriate.
2. Ratings are based on:
Cooling Standard: 80°F (27°C) db, 67°F (19°C) wb indoor air temp and 95°F (35°C) db outdoor air temp.
IEER Standard: A measure that expresses cooling part-load EER efficiency for commercial unitary air conditioning and heat pump equipment on the basis of weighted operation at various load capacities.
3. All 48TC units comply with ASHRAE 90.1 Energy Standard for minimum SEER and EER requirements.
4. 48TC units comply with US Energy Policy Act (2005). To evaluate code compliance requirements, refer to state and local codes.



**ASHRAE
90.1
COMPLIANT**



Use of the AHRI Certified TM Mark indicates a manufacturer's participation in the program. For verification of certification for individual products, go to www.ahridirectory.org.

Table 3 – HEATING RATING TABLE - NATURAL GAS & PROPANE

UNITS	GAS HEAT	AL/SS HEAT EXCHANGER		TEMP RISE (DEG F)	THERMAL EFFICIENCY (%)	AFUE (%)	
		INPUT / OUTPUT STAGE 1 (MBH)	INPUT / OUTPUT STAGE 2 (MBH)				
Single Phase	04	LOW	–	72 / 56	25 – 55	82%	79.1%
		MED	–	115 / 89	55 – 85	80%	78.5%
		HIGH	–	–	–	–	–
	05	LOW	–	72 / 56	25 – 55	82%	79.1%
		MED	–	115 / 90	35 – 65	81%	79%
		HIGH	–	150 / 117	50 – 80	80%	78.8%
	06	LOW	–	72 / 56	20 – 55	82%	79.1%
		MED	–	115 / 90	30 – 65	81%	79%
		HIGH	–	150 / 117	40 – 80	80%	78.8%
Three Phase	04	LOW	–	72 / 56	25 – 55	82%	N/A
		MED	82 / 66	115 / 89	55 – 85	80%	N/A
		HIGH	–	–	–	–	–
	05	LOW	–	72 / 56	25 – 55	82%	N/A
		MED	–	115 / 90	35 – 65	81%	N/A
		HIGH	120 / 96	150 / 117	50 – 80	80%	N/A
	06	LOW	–	72 / 56	20 – 55	82%	N/A
		MED	–	115 / 90	30 – 65	81%	N/A
		HIGH	120 / 96	150 / 117	40 – 80	80%	N/A
	07	LOW	–	72 / 59	15 – 55	82%	N/A
		MED	–	115 / 93	25 – 65	81%	N/A
		HIGH	120 / 96	150 / 120	35 – 80	80%	N/A
	08	LOW	–	125 / 103	20 – 50	82%	N/A
		MED	120 / 98	180 / 148	35 – 65	82%	N/A
		HIGH	180 / 147	224 / 184	45 – 75	82%	N/A
	09	LOW	–	125 / 103	20 – 50	82%	N/A
		MED	120 / 98	180 / 148	30 – 65	82%	N/A
		HIGH	180 / 147	224 / 184	40 – 75	82%	N/A
12	LOW	120 / 98	180 / 148	25 – 65	82%	N/A	
	MED	180 / 147	224 / 184	30 – 65	82%	N/A	
	HIGH	200 / 160	250 / 205	35 – 70	80%	N/A	
14	LOW	120 / 98	180 / 148	20 – 65	82%	N/A	
	MED	180 / 147	224 / 184	25 – 65	82%	N/A	
	HIGH	200 / 160	250 / 205	25 – 70	80%	N/A	
16	LOW	144 / 118	180 / 146	15 – 55	81%	N/A	
	MED	192 / 156	240 / 195	20 – 60	81%	N/A	
	HIGH	280 / 224	350 / 280	35 – 65	80%	N/A	

NOTES:

Heat ratings are for natural gas heat exchangers operated at or below 2000 ft (610 m). For information on propane or altitudes above 2000 ft (610 m), see the Application Data section of this book. Accessory Propane/High Altitude kits are also available.

In the USA the input rating for altitudes above 2000 ft (610m) must be derated by 4% for each 1000 ft (305 m) above sea level. In Canada, the input rating must be derated by 10% for altitudes of 2000 ft (610 m) to 4500 ft (1372 m) above sea level.

Table 4 – HEATING RATING TABLE - LOW NO_x¹

UNIT	GAS HEAT	LOW NO _x HEAT EXCHANGER		TEMP RISE (DEG F)	THERMAL EFFICIENCY (%)	AFUE (%)	
		INPUT / OUTPUT STAGE 1 (MBH)	INPUT / OUTPUT STAGE 2 (MBH)				
Single Phase	04	LOW	–	60 / 47	20 – 50	81%	80.6%
		MED	–	90 / 72	30 – 60	81%	80.6%
		HIGH	–	–	–	–	–
	05	LOW	–	60 / 47	20 – 50	81%	80.6%
		MED	–	90 / 72	30 – 60	81%	80.6%
		HIGH	–	120 / 97	40 – 70	81%	81.5%
	06	LOW	–	60 / 47	15 – 50	81%	80.6%
		MED	–	90 / 72	25 – 60	80%	80.6%
		HIGH	–	120 / 97	35 – 70	80%	81.5%
Three Phase	04	LOW	–	60 / 47	20 – 50	81%	N/A
		MED	–	90 / 72	30 – 60	81%	N/A
		HIGH	–	–	–	–	–
	05	LOW	–	60 / 47	20 – 50	81%	N/A
		MED	–	90 / 72	30 – 60	81%	N/A
		HIGH	–	120 / 97	40 – 70	81%	N/A
	06	LOW	–	60 / 47	15 – 50	81%	N/A
		MED	–	90 / 72	25 – 60	80%	N/A
		HIGH	–	120 / 97	35 – 70	80%	N/A

NOTE:

- Units meet California’s South Coast Air Quality Management District (SCAQMD) Low–NO_x emissions requirement of 40 nanograms per joule or less.
- Not Applicable

Table 5 – SOUND PERFORMANCE TABLE

UNIT	COOLING STAGES	OUTDOOR SOUND (dB)								
		A–WEIGHTED	63	125	250	500	1000	2000	4000	8000
A04	1	80	90.6	80.9	80.2	76	74.6	71.3	68.5	63.9
A05	1	81	90.9	84.6	79.5	77.9	76.5	71.1	66.9	62.5
A06	1	78	84.0	82.2	76.3	74.8	72.5	68.8	65.6	61.8
A07	1	78	88.8	81.8	76.9	74.4	73.3	69.8	66.3	62.7
A08	1	82	90.1	82.6	81.0	79.4	77.0	73.0	70.4	66.7
D08	2	82	85.8	84.3	80.5	78.7	76.4	72.7	68.3	65.1
A09	1	83	91.2	86.4	81.9	81.0	78.3	73.9	71.4	67.3
D09	2	82	88.6	85.0	81.6	79.5	77.4	74.1	71.0	66.3
A12	1	82	88.6	85.0	81.6	79.5	77.4	74.1	71.0	66.3
D12	2	82	89.0	83.1	80.5	78.5	75.5	71.6	69.6	69.3
D14	2	87	87.0	85.2	84.6	84.9	82.2	78.4	75.3	72.9
D16	2	87	87.0	85.2	84.6	84.9	82.2	78.4	75.3	72.9

LEGEND

dB – Decibel



NOTES:

- Outdoor sound data is measure in accordance with AHRI standard 270–2008.
- Measurements are expressed in terms of sound power. Do not compare these values to sound pressure values because sound pressure depends on specific environmental factors which normally do not match individual applications. Sound power values are independent of the environment and therefore more accurate.
- A–weighted sound ratings filter out very high and very low frequencies, to better approximate the response of “average” human ear. A–weighted measurements for Carrier units are taken in accordance with AHRI standard 270–2008.

Table 6 – MINIMUM - MAXIMUM AIRFLOW RATINGS - NATURAL GAS & PROPANE

UNIT	HEAT LEVEL	COOLING				HEATING	
		Minimum Single Speed Fan Motor	Minimum 2-speed Fan Motor (at high speed)	Minimum 2-speed Fan Motor (at low speed)	Maximum	Minimum	Minimum
48TC**04	LOW	900	-	-	1500	990	2190
	MED					1000	1550
	HIGH					-	-
48TC**05	LOW	1200	-	-	2000	990	2190
	MED					1330	2460
	HIGH					1390	2220
48TC**06	LOW	1500	-	-	2500	990	2730
	MED					1330	2880
	HIGH					1390	2780
48TC**07	LOW	1800	-	-	3000	990	3640
	MED					1330	3450
	HIGH					1390	3170
48TC**08	LOW	2250	2250	1485	3750	1900	4750
	MED					2100	3900
	HIGH					2270	3780
48TC**09	LOW	2550	2873	1896	4250	1900	4750
	MED					2100	4560
	HIGH					2270	4250
48TC**12	LOW	3000	3380	2231	5000	2100	5470
	MED					2620	5670
	HIGH					2650	5290
48TC**14	LOW	3600	4225	2789	6000	2100	6830
	MED					2620	6800
	HIGH					2650	7410
48TC**16	LOW	4500	5625	3713	7500	2450	7500
	MED					3000	6750
	HIGH					3990	7200

Table 7 – PHYSICAL DATA

(COOLING)

3 - 6 TONS

		48TC*A04	48TC*A05	48TC*A06	48TC*A07
Refrigeration System					
# Circuits / # Comp. / Type		1 / 1 / Scroll	1 / 1 / Scroll	1 / 1 / Scroll	1 / 1 / Scroll
Puron® refrig. (R-410A) (lbs-oz)		5-10	8-8	10-11	14-2
Humidi-MiZer Puron® refrig. charge A/B (lbs - oz)		8-11	14-13	16-0	22-5
Metering Device		Acutrol	Acutrol	Acutrol	Acutrol
High-press. Trip / Reset (psig)		630 / 505	630 / 505	630 / 505	630 / 505
Low-press. Trip / Reset (psig)		54 / 117	54 / 117	54 / 117	54 / 117
Compressor Capacity Staging (%)		100%	100%	100%	100%
Evap. Coil					
Material (Tube/Fin)		Cu / Al	Cu / Al	Cu / Al	Cu / Al
Coil type		3/8-in RTPF	3/8-in RTPF	3/8-in RTPF	3/8-in RTPF
Rows / FPI		2 / 15	2 / 15	4 / 15	4 / 15
Total Face Area (ft ²)		5.5	5.5	5.5	7.3
Condensate Drain Conn. Size		3/4-in	3/4-in	3/4-in	3/4-in
Evap. Fan and Motor					
Standard Static 1 phase	Motor Qty / Drive Type	1 / Belt	1 / Belt	1 / Belt	-
	Max BHP	1.2	1.2	1.2	-
	RPM Range	560-854	560-854	770-1175	-
	Motor Frame Size	48	48	48	-
	Fan Qty / Type	1 / Centrifugal	1 / Centrifugal	1 / Centrifugal	-
	Fan Diameter (in)	10 x 10	10 x 10	10 x 10	-
Medium Static 1 phase	Motor Qty / Drive Type	1 / Belt	1 / Belt	1 / Belt	-
	Max BHP	1.2	1.2	1.5	-
	RPM Range	770-1175	770-1175	1035-1466	-
	Motor Frame Size	48	48	56	-
	Fan Qty / Type	1 / Centrifugal	1 / Centrifugal	1 / Centrifugal	-
	Fan Diameter (in)	10 x 10	10 x 10	10 x 10	-
Standard Static 3 phase	Motor Qty / Drive Type	1 / Belt	1 / Belt	1 / Belt	1 / Belt
	Max BHP	1.2	1.2	1.5	2.4
	RPM Range	560-854	560-854	770-1175	1073-1457
	Motor Frame Size	48	48	48	56
	Fan Qty / Type	1 / Centrifugal	1 / Centrifugal	1 / Centrifugal	1 / Centrifugal
	Fan Diameter (in)	10 x 10	10 x 10	10 x 10	10 x 10
Medium Static 3 phase	Motor Qty / Drive Type	1 / Belt	1 / Belt	1 / Belt	1 / Belt
	Max BHP	1.2	1.2	2.4	2.9*
	RPM Range	770-1175	770-1175	1035-1466	1173-1518
	Motor Frame Size	48	48	56	56
	Fan Qty / Type	1 / Centrifugal	1 / Centrifugal	1 / Centrifugal	1 / Centrifugal
	Fan Diameter (in)	10 x 10	10 x 10	10 x 10	10 x 10
High Static 3 phase	Motor Qty / Drive Type	1 / Belt	1 / Belt	1 / Belt	1 / Belt
	Max BHP	2.4	2.4	2.9	3.7
	RPM Range	1035-1466	1035-1466	1303-1687	1474-1788
	Motor Frame Size	56	56	56	56
	Fan Qty / Type	1 / Centrifugal	1 / Centrifugal	1 / Centrifugal	1 / Centrifugal
	Fan Diameter (in)	10 x 10	10 x 10	10 x 10	10 x 10
Cond. Coil					
Material (Tube/Fin)		Cu / Al	Cu / Al	Cu / Al	Cu / Al
Coil type		3/8-in RTPF	3/8-in RTPF	3/8-in RTPF	3/8-in RTPF
Rows / FPI		1 / 17	2 / 17	2 / 17	2 / 17
Total Face Area (ft ²)		14.6	16.5	16.5	21.3
Humidi-MiZer Coil					
Material (Tube/Fin)		Cu / Al	Cu / Al	Cu / Al	Cu / Al
Rows..Fins/in.		1 / 17	2 / 17	2 / 17	2 / 17
Total Face Area (ft ²)		3.9	3.9	3.9	5.2
Cond. fan / motor					
Qty / Motor Drive Type		1/ Direct	1/ Direct	1/ Direct	1/ Direct
Motor HP / RPM		1/4 / 1100	1/4 / 1100	1/4 / 1100	1/4 / 1100
Fan diameter (in)		22	22	22	22
Filters					
RA Filter # / Size (in)		2 / 16 x 25 x 2	2 / 16 x 25 x 2	2 / 16 x 25 x 2	4 / 16 x 16 x 2
OA inlet screen # / Size (in)		1 / 20 x 24 x 1	1 / 20 x 24 x 1	1 / 20 x 24 x 1	1 / 20 x 24 x 1

NOTE: Humidi-MiZer is not available with Novation condenser coil models, only Round Tube / Plate Fin (RTPF).

* 575V motor utilizes 3.7 BHP.

- Not applicable

Table 8 – PHYSICAL DATA

(HEATING)

3 - 6 TONS

		48TC**04	48TC**05	48TC**06	48TC**07
Gas Connection					
	# of Gas Valves	1	1	1	1
	Nat. gas supply line press (in. w.g.) / (PSIG)	4 -13 / 0.18 - 0.47	4 -13 / 0.18 - 0.47	4 -13 / 0.18 - 0.47	4 -13 / 0.18 - 0.47
	LP supply line press (in. w.g.) / (PSIG)	11 -13 / 0.40 - 0.47	11 -13 / 0.40 - 0.47	11 -13 / 0.40 - 0.47	11 -13 / 0.40 - 0.47
Heat Anticipator setting (Amps)					
	1st stage	0.14	0.14	0.14	0.14
	2nd stage	0.14	0.14	0.14	0.14
Natural Gas Heat					
LOW	# of stages / # of burners (total)	1 / 2	1 / 2	1 / 2	1 / 2
	Connection Size	1/2-in NPT	1/2-in NPT	1/2-in NPT	1/2-in NPT
	Rollout switch opens / closes	195 / 115	195 / 115	195 / 115	195 / 115
	Temperature Rise	25 - 55	25 - 55	20 - 55	15 - 55
MED	# of stages / # of burners (total)	1 or 2 / 3	1 / 3	1 / 3	1 / 3
	Connection Size	1/2-in NPT	1/2-in NPT	1/2-in NPT	1/2-in NPT
	Rollout switch opens / closes	195 / 115	195 / 115	195 / 115	195 / 115
	Temperature Rise	55 - 85	35 - 65	30 - 65	25 - 65
HIGH	# of stages / # of burners (total)	-	1 or 2 / 3	1 or 2 / 3	2 / 3
	Connection Size	-	1/2-in NPT	1/2-in NPT	1/2-in NPT
	Rollout switch opens / closes	-	195 / 115	195 / 115	195 / 115
	Temperature Rise	-	50 - 80	40 - 80	35 - 80
Liquid Propane Heat					
LOW	# of stages / # of burners (total)	1 / 2	1 / 2	1 / 2	1 / 2
	Connection Size	1/2-in NPT	1/2-in NPT	1/2-in NPT	1/2-in NPT
	Rollout switch opens / closes	195 / 115	195 / 115	195 / 115	195 / 115
	Temperature Rise	25 - 55	25 - 55	20 - 55	15 - 55
MED	# of stages / # of burners (total)	1 or 2 / 3	1 / 3	1 / 3	1 / 3
	Connection Size	1/2-in NPT	1/2-in NPT	1/2-in NPT	1/2-in NPT
	Rollout switch opens / closes	195 / 115	195 / 115	195 / 115	195 / 115
	Temperature Rise	55 - 85	35 - 65	30 - 65	25 - 65
HIGH	# of stages / # of burners (total)	-	1 or 2 / 3	1 or 2 / 3	2 / 3
	Connection Size	-	1/2-in NPT	1/2-in NPT	1/2-in NPT
	Rollout switch opens / closes	-	195 / 115	195 / 115	195 / 115
	Temperature Rise	-	50 - 80	40 - 80	35 - 80
Low NOx Gas Heat					
LOW	# of stages / # of burners (total)	1 / 2	1 / 2	1 / 2	-
	Connection Size	1/2-in NPT	1/2-in NPT	1/2-in NPT	-
	Rollout switch opens / closes	195 / 115	195 / 115	195 / 115	-
	Temperature Rise	20 - 50	20 - 50	15 - 50	-
MED	# of stages / # of burners (total)	1 / 3	1 / 3	1 / 3	-
	Connection Size	1/2-in NPT	1/2-in NPT	1/2-in NPT	-
	Rollout switch opens / closes	195 / 115	195 / 115	195 / 115	-
	Temperature Rise	30 - 60	30 - 60	25 - 60	-
HIGH	# of stages / # of burners (total)	-	1 / 3	1 / 3	-
	Connection Size	-	1/2-in NPT	1/2-in NPT	-
	Rollout switch opens / closes	-	195 / 115	195 / 115	-
	Temperature Rise	-	40 - 70	35 - 70	-

- Not applicable

Table 9 – PHYSICAL DATA

(COOLING)

7.5 - 8.5 TONS

		48TC*A08	48TC*D08	48TC*A09	48TC*D09
Refrigeration System					
# Circuits / # Comp. / Type		1 / 1 / Scroll	2 / 2 / Scroll	1 / 1 / Scroll	2 / 2 / Scroll
RTPF models R-410a charge A/B (lbs – oz)		13 – 12	8 – 5 / 8 – 2	15 – 4	10 – 5 / 10 – 12
Alternate (MCHX) R-410a charge A/B (lbs – oz)			4 – 6 / 4 – 6		
Alternate (Humidi–MiZer) R-410a charge A/B (lbs – oz)			13 – 3 / 13 – 3		16 – 13 / 16 – 13
Metering device		Acutrol	Acutrol	Acutrol	Acutrol
High–press. Trip / Reset (psig)		630 / 505	630 / 505	630 / 505	630 / 505
Low–press. Trip / Reset (psig)		54 / 117	54 / 117	54 / 117	54 / 117
Compressor Capacity Staging (%)		100%	50% / 100%	100%	50% / 100%
Evap. Coil					
Material		Cu / Al	Cu / Al	Cu / Al	Cu / Al
Coil type		3/8–in RTPF	3/8–in RTPF	3/8–in RTPF	3/8–in RTPF
Rows / FPI		3 / 15	3 / 15	3 / 15	3 / 15
Total face area (ft ²)		8.9	8.9	11.1	11.1
Condensate drain conn. size		3/4–in	3/4–in	3/4–in	3/4–in
Humidi–MiZer Coil					
Material		–	Cu / Al	–	Cu / Al
Coil type		–	3/8–in RTPF	–	3/8–in RTPF
Rows / FPI		–	2 / 17	–	2 / 17
Total face area (ft ²)		–	6.3	–	8.4
Evap. fan and motor					
Standard Static 3 phase	Motor Qty / Drive Type	1 / Belt	1 / Belt	1 / Belt	1 / Belt
	Max BHP	1.7	1.7	1.7	1.7
	RPM range	489–747	489–747	518–733	518–733
	Motor frame size	56	56	56	56
	Fan Qty / Type	1 / Centrifugal	1 / Centrifugal	1 / Centrifugal	1 / Centrifugal
	Fan Diameter (in)	15 x 15	15 x 15	15 x 15	15 x 15
Medium Static 3 phase	Motor Qty / Drive type	1 / Belt	1 / Belt	1 / Belt	1 / Belt
	Max BHP	2.9*	2.9*	2.4	2.4
	RPM range	733–949	733–949	690–936	690–936
	Motor frame size	56	56	56	56
	Fan Qty / Type	1 / Centrifugal	1 / Centrifugal	1 / Centrifugal	1 / Centrifugal
	Fan Diameter (in)	15 x 15	15 x 15	15 x 15	15 x 15
High Static 3 phase	Motor Qty / Drive type	1 / Belt	1 / Belt	1 / Belt	1 / Belt
	Max BHP	4.7	4.7	3.7	3.7
	RPM range	909–1102	909–1102	838–1084	838–1084
	Motor frame size	14	14	56	56
	Fan Qty / Type	1 / Centrifugal	1 / Centrifugal	1 / Centrifugal	1 / Centrifugal
	Fan Diameter (in)	15 x 15	15 x 15	15 x 15	15 x 15
Cond. Coil					
Material		Cu / Al	Cu / Al	Cu / Al	Cu / Al
Coil type		3/8–in RTPF	3/8–in RTPF	3/8–in RTPF	3/8–in RTPF
Rows / FPI		2 / 17	2 / 17	2 / 17	2 / 17
Total face area (ft ²)		20.5	20.5	21.4	25.1
Alternate (MCHX) Cond. Coil					
Material		–	Al / Al	–	–
Coil type		–	Novation™	–	–
Rows / FPI		–	1 / 20	–	–
Total face area (ft ²)		–	20.5	–	–
Cond. fan / motor					
Qty / Motor drive type		2 / direct	2 / direct	2 / direct	2 / direct
Motor HP / RPM		1/4 / 1100	1/4 / 1100	1/4 / 1100	1/4 / 1100
Fan diameter (in)		22	22	22	22
Filters					
RA Filter # / Size (in)		4 / 16 x 20 x 2	4 / 16 x 20 x 2	4 / 16 x 20 x 2	4 / 16 x 20 x 2
OA inlet screen # / Size (in)		1 / 20 x 24 x 1	1 / 20 x 24 x 1	1 / 20 x 24 x 1	1 / 20 x 24 x 1

NOTE: Humidi–MiZer is not available with Novation condenser coil models, only Round Tube/Plate Fin (RTPF).

* 575V motor utilizes 3.7 BHP

– Not applicable

Table 10 – PHYSICAL DATA

(COOLING)

10 - 15 TONS

		48TC*A12	48TC*D12	48TC*D14	48TC*D16
Refrigeration System					
# Circuits / # Comp. / Type		1 / 1 / Scroll	2 / 2 / Scroll	2 / 2 / Scroll	2 / 2 / Scroll
RTPF models R-410a charge A/B (lbs – oz)		20 – 0	10 – 5 / 10 – 3	11 – 0 / 11 – 6	15 – 14 / 16 – 12
Alternate (MCHX) R-410a charge A/B (lbs – oz)		–	6 – 0 / 6 – 0	7 – 6 / 8 – 0	–
Alternate (Humidi-MiZer) R-410a charge A/B (lbs – oz)		–	16 – 10 / 16 – 0	17 – 10 / 18 – 3	–
Metering device		Acutrol	Acutrol	Acutrol	Acutrol
High–press. Trip / Reset (psig)		630 / 505	630 / 505	630 / 505	630 / 505
Low–press. Trip / Reset (psig)		54 / 117	54 / 117	54 / 117	54 / 117
Compressor Capacity Staging (%)		100%	50% / 100%	50% / 100%	50% / 100%
Evap. Coil					
Material		Cu / Al	Cu / Al	Cu / Al	Cu / Al
Coil type		3/8–in RTPF	3/8–in RTPF	3/8–in RTPF	3/8–in RTPF
Rows / FPI		4 / 15	4 / 15	4 / 15	3 / 15
Total face area (ft ²)		11.1	11.1	11.1	17.5
Condensate drain conn. size		3/4–in	3/4–in	3/4–in	3/4–in
Humidi–MiZer Coil					
Material		–	Cu / Al	Cu / Al	Cu / Al
Coil type		–	3/8–in RTPF	3/8–in RTPF	3/8–in RTPF
Rows / FPI		–	2 / 17	2 / 17	1 / 17
Total face area (ft ²)		–	8.4	8.4	13.8
Evap. fan and motor					
Standard Static 3 phase	Motor Qty / Drive type	1 / Belt	1 / Belt	1 / Belt	1 / Belt
	Max BHP	2.4	2.4	2.9*	2.9*
	RPM range	591–838	591–838	652–843	507–676
	Motor frame size	56	56	56	56
	Fan Qty / Type	1 / Centrifugal	1 / Centrifugal	1 / Centrifugal	1 / Centrifugal
Fan Diameter (in)	15 x 15	15 x 15	15 x 15	18 x 18	
Medium Static 3 phase	Motor Qty / Drive type	1 / Belt	1 / Belt	1 / Belt	1 / Belt
	Max BHP	3.7	3.7	3.7	3.7
	RPM range	838–1084	838–1084	838–1084	627–851
	Motor frame size	56	56	56	56
	Fan Qty / Type	1 / Centrifugal	1 / Centrifugal	1 / Centrifugal	1 / Centrifugal
Fan Diameter (in)	15 x 15	15 x 15	15 x 15	18 x 18	
High Static 3 phase	Motor Qty / Drive type	1 / Belt	1 / Belt	1 / Belt	1 / Belt
	Max BHP	4.7	4.7	4.7	6.1
	RPM range	1022–1240	1022–1240	1022–1240	776–955
	Motor frame size	14	14	14	S184T
	Fan Qty / Type	1 / Centrifugal	1 / Centrifugal	1 / Centrifugal	1 / Centrifugal
Fan Diameter (in)	15 x 15	15 x 15	15 x 15	18 x 18	
Cond. Coil					
Material		Cu / Al	Cu / Al	Cu / Al	Cu / Al
Coil type		3/8–in RTPF	3/8–in RTPF	3/8–in RTPF	3/8–in RTPF
Rows / FPI		2 / 17	2 / 17	3 / 17	2 / 17
Total face area (ft ²)		25.1	25.1	25.1	2 @ 23.1
Alternate (MCHX) Cond. Coil					
Material		–	Al / Al	Al / Al	–
Coil type		–	Novation™	Novation™	–
Rows / FPI		–	1 / 20	2 / 20	–
Total face area (ft ²)		–	25.1	25.1	–
Cond. fan / motor					
Qty / Motor drive type		2 / direct	2 / direct	1 / direct	3 / direct
Motor HP / RPM		1/4 / 1100	1/4 / 1100	1 / 1175	1/4 / 1100
Fan diameter (in)		22	22	30	22
Filters					
RA Filter # / Size (in)		4 / 20 x 20 x 2	4 / 20 x 20 x 2	4 / 20 x 20 x 2	6 / 18 x 24 x 2 2 / 24 x 27 x 1 (vert.)
OA inlet screen # / Size (in)		1 / 20 x 24 x 1	1 / 20 x 24 x 1	1 / 20 x 24 x 1	1 / 30 x 39 x 1 (horiz)

NOTE: Humidi–MiZer is not available with Novation condenser coil models, only Round Tube/Plate Fin (RTPF) up to 16 size.

* 575V motor utilizes 3.7 BHP

– Not applicable

Table 11 – PHYSICAL DATA

(HEATING)

7.5 - 10 TONS

		48TC**08	48TC**09	48TC**12
Gas Connection				
	# of Gas Valves	1	1	1
	Nat. gas supply line press (in. w.g.) / (PSIG)	4 – 13 / 0.18 – 0.47	4 – 13 / 0.18 – 0.47	4 – 13 / 0.18 – 0.47
	LP supply line press (in. w.g.) / (PSIG)	11 – 13 / 0.40 – 0.47	11 – 13 / 0.40 – 0.47	11 – 13 / 0.40 – 0.47
Heat Anticipator setting (Amps)				
	1st stage	0.14	0.14	0.14
	2nd stage	0.14	0.14	0.14
Natural Gas Heat				
LOW	# of stages / # of burners (total)	1 / 3	1 / 3	2 / 4
	Connection Size	1/2-in NPT	1/2-in NPT	3/4-in NPT
	Rollout switch opens / closes	195 / 115	195 / 115	195 / 115
	Temperature Rise	20 – 50	20 – 50	25 – 65
MED	# of stages / # of burners (total)	2 / 4	2 / 4	2 / 5
	Connection Size	3/4-in NPT	3/4-in NPT	3/4-in NPT
	Rollout switch opens / closes	195 / 115	195 / 115	195 / 115
	Temperature Rise	35 – 65	30 – 65	30 – 65
HIGH	# of stages / # of burners (total)	2 / 5	2 / 5	2 / 5
	Connection Size	3/4-in NPT	3/4-in NPT	3/4-in NPT
	Rollout switch opens / closes	195 / 115	195 / 115	195 / 115
	Temperature Rise	45 – 75	40 – 75	35 – 70
Liquid Propane Heat				
LOW	# of stages / # of burners (total)	1 / 3	1 / 3	2 / 4
	Connection Size	1/2-in NPT	1/2-in NPT	3/4-in NPT
	Rollout switch opens / closes	195 / 115	195 / 115	195 / 115
	Temperature Rise	20 – 50	20 – 50	25 – 65
MED	# of stages / # of burners (total)	2 / 4	2 / 4	2 / 5
	Connection Size	3/4-in NPT	3/4-in NPT	3/4-in NPT
	Rollout switch opens / closes	195 / 115	195 / 115	195 / 115
	Temperature Rise	35 – 65	30 – 65	30 – 65
HIGH	# of stages / # of burners (total)	2 / 5	2 / 5	2 / 5
	Connection Size	3/4-in NPT	3/4-in NPT	3/4-in NPT
	Rollout switch opens / closes	195 / 115	195 / 115	195 / 115
	Temperature Rise	45 – 75	40 – 75	35 – 70
Low NOx Gas Heat				
LOW	# of stages / # of burners (total)	-	-	-
	Connection Size	-	-	-
	Rollout switch opens / closes	-	-	-
	Temperature Rise	-	-	-
MED	# of stages / # of burners (total)	-	-	-
	Connection Size	-	-	-
	Rollout switch opens / closes	-	-	-
	Temperature Rise	-	-	-
HIGH	# of stages / # of burners (total)	-	-	-
	Connection Size	-	-	-
	Rollout switch opens / closes	-	-	-
	Temperature Rise	-	-	-

- Not applicable

Table 12 – PHYSICAL DATA

(HEATING)



12.5 - 15 TONS

		48TC**14	48TC**16
Gas Connection			
	# of Gas Valves	1	1
	Nat. gas supply line press (in. w.g.) / (PSIG)	4 – 13 / 0.18 – 0.47	5 – 13 / 0.18 – 0.47
	LP supply line press (in. w.g.) / (PSIG)	11 – 13 / 0.40 – 0.47	11 – 13 / 0.40 – 0.47
Heat Anticipator setting (Amps)			
	1st stage	0.14	0.14
	2nd stage	0.14	0.14
Natural Gas Heat			
LOW	# of stages / # of burners (total)	2 / 4	2 / 6
	Connection Size	3/4-in NPT	3/4-in NPT
	Rollout switch opens / closes	195 / 115	225 / 145
	Temperature Rise	25 – 65	20 – 55
MED	# of stages / # of burners (total)	2 / 5	2 / 8
	Connection Size	3/4-in NPT	3/4-in NPT
	Rollout switch opens / closes	195 / 115	225 / 145
	Temperature Rise	30 – 65	25 – 60
HIGH	# of stages / # of burners (total)	2 / 5	2 / 10
	Connection Size	3/4-in NPT	3/4-in NPT
	Rollout switch opens / closes	195 / 115	225 / 145
	Temperature Rise	35 – 70	35 – 65
Liquid Propane Heat			
LOW	# of stages / # of burners (total)	2 / 4	2 / 6
	Connection Size	3/4-in NPT	3/4-in NPT
	Rollout switch opens / closes	195 / 115	225 / 145
	Temperature Rise	25 – 65	20 – 55
MED	# of stages / # of burners (total)	2 / 5	2 / 8
	Connection Size	3/4-in NPT	3/4-in NPT
	Rollout switch opens / closes	195 / 115	225 / 145
	Temperature Rise	30 – 65	25 – 60
HIGH	# of stages / # of burners (total)	2 / 5	2 / 10
	Connection Size	3/4-in NPT	3/4-in NPT
	Rollout switch opens / closes	195 / 115	225 / 145
	Temperature Rise	35 – 70	35 – 65
Low NOx Gas Heat			
LOW	# of stages / # of burners (total)	-	-
	Connection Size	-	-
	Rollout switch opens / closes	-	-
	Temperature Rise	-	-
MED	# of stages / # of burners (total)	-	-
	Connection Size	-	-
	Rollout switch opens / closes	-	-
	Temperature Rise	-	-
HIGH	# of stages / # of burners (total)	-	-
	Connection Size	-	-
	Rollout switch opens / closes	-	-
	Temperature Rise	-	-

- Not applicable

CURBS, WEIGHTS & DIMENSIONS

NOTES:

1. DIMENSIONS ARE IN INCHES, DIMENSIONS IN [] ARE IN MILLIMETERS.
2.  CENTER OF GRAVITY
3.  DIRECTION OF AIR FLOW

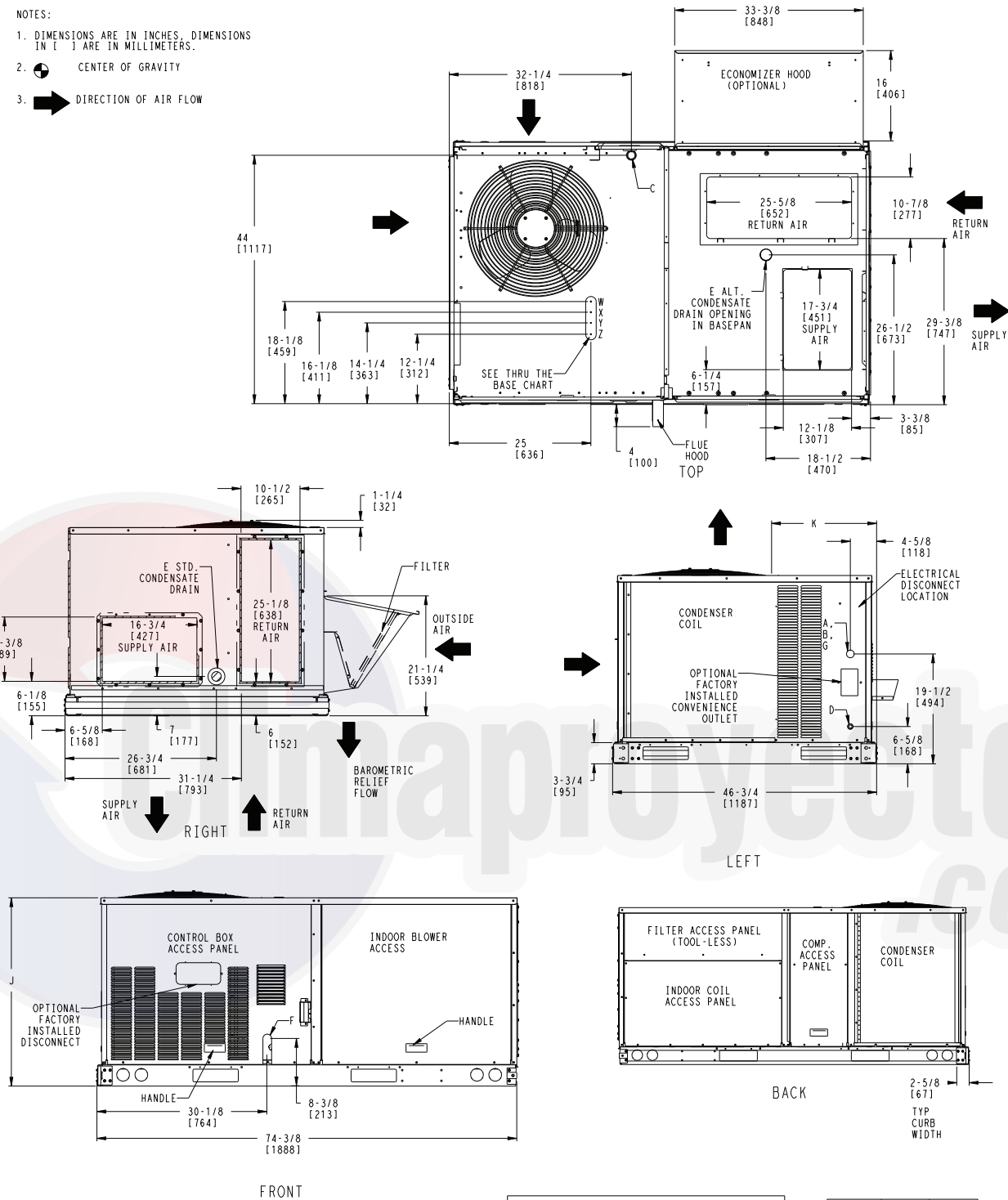

CONNECTION SIZES	
A	1 3/8" [35] DIA FIELD POWER SUPPLY HOLE
B	2" [50] DIA POWER SUPPLY KNOCKOUT
C	1 3/4" [51] DIA GAUGE ACCESS PLUG
D	7/8" [22] DIA FIELD CONTROL WIRING HOLE
E	3/4"-14 NPT CONDENSATE DRAIN
F	1/2"-14 NPT GAS CONNECTION
G	2 1/2" [64] DIA POWER SUPPLY KNOCK-OUT

THRU-THE-BASE CHART THESE HOLES REQUIRED FOR USE CRBTMPW001A01, 003A01			
	THREADED CONDUIT SIZE	WIRE USE	REQ'D HOLE SIZES (MAX.)
W	1/2"	ACC.	7/8" [22.2]
X	1/2"	24V	7/8" [22.2]
Y *	3/4" (001, 003)	POWER	1 1/8" [28.4]
Z**	(003) 1/2" FPT	GAS	1 3/16" [30.0]
FOR "THRU-THE-BASEPAN" FACTORY OPTION, FITTINGS FOR ONLY X, Y, & Z ARE PROVIDED			
* SELECT EITHER 3/4" OR 1/2" FOR POWER, DEPENDING ON WIRE SIZE			
** (001) PROVIDES 3/4" FPT THRU CURB FLANGE & FITTING.			

UNIT	J	K
48TC-A04	33 3/8 [847]	18 5/8 [472]
48TC-A05	33 3/8 [847]	14 7/8 [377]
48TC-A06	33 3/8 [847]	14 7/8 [377]
48TC-A07	41 3/8 [1051]	14 7/8 [377]

Fig. 1 - Dimensions 48TC 04-07

A10484

CURBS, WEIGHTS & DIMENSIONS (cont.)

UNIT	STD. UNIT WEIGHT		CORNER WEIGHT (A)		CORNER WEIGHT (B)		CORNER WEIGHT (C)		CORNER WEIGHT (D)		C.G.		HEIGHT
	LBS.	KG.	LBS.	KG.	LBS.	KG.	LBS.	KG.	LBS.	KG.	X	Y	Z
48TC-A04	483	219	111	50	125	57	131	59	116	53	39 [991]	23 [584]	16 3/8 [416]
48TC-A05	537	244	124	56	139	63	145	66	129	59	39 [991]	23 [584]	17 [432]
48TC-A06	569	258	131	59	147	67	154	70	137	62	39 [991]	23 [584]	17 1/4 [438]
48TC-A07	652	296	150	68	169	76	176	80	157	71	39 [991]	23 [584]	20 1/8 [511]

*STANDARD UNIT WEIGHT IS WITH LOW HEAT & WITHOUT PACKAGING.
FOR OPTIONS & ACCESSORIES, REFER TO THE PRODUCT DATA CATALOG.

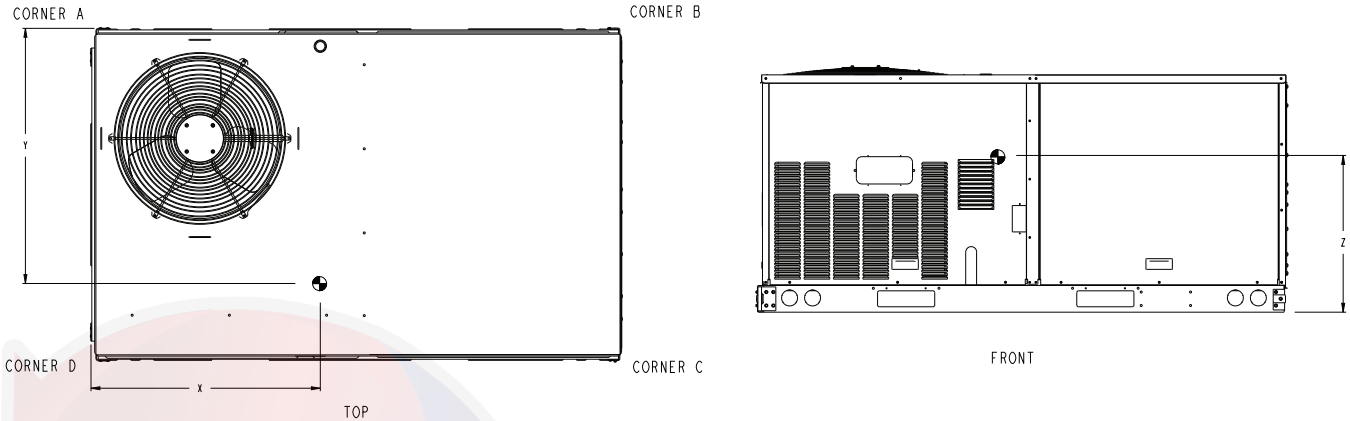

Fig. 2 - Dimensions 48TC 04-07

A10485A

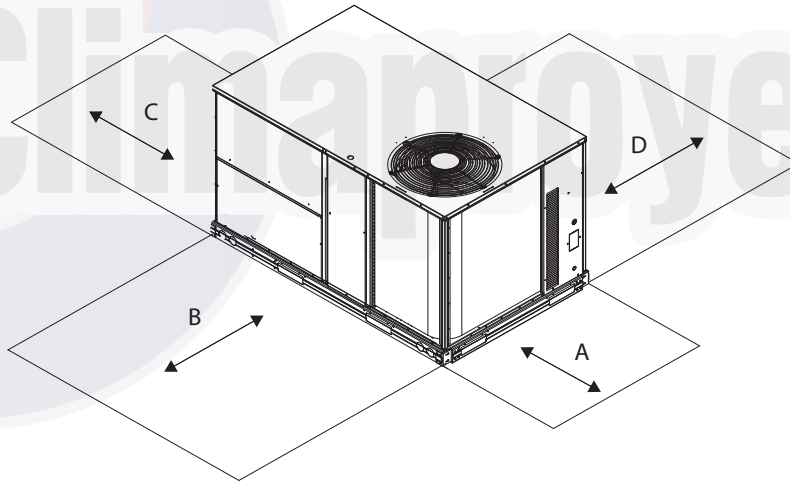

Fig. 3 - Service Clearance

C08337

LOC	DIMENSION	CONDITION
A	48-in (1219 mm)	Unit disconnect is mounted on panel
	18-in (457 mm)	No disconnect, convenience outlet option
	18-in (457 mm)	Recommended service clearance
	12-in (305 mm)	Minimum clearance
B	42-in (1067 mm)	Surface behind servicer is grounded (e.g., metal, masonry wall)
	36-in (914 mm)	Surface behind servicer is electrically non-conductive (e.g., wood, fiberglass)
	Special	Check for sources of flue products within 10-ft of unit fresh air intake hood
C	36-in (914 mm)	Side condensate drain is used
	18-in (457 mm)	Minimum clearance
D	48-in (1219 mm)	No flue discharge accessory installed, surface is combustible material
	42-in (1067 mm)	Surface behind servicer is grounded (e.g., metal, masonry wall, another unit)
	36-in (914 mm)	Surface behind servicer is electrically non-conductive (e.g., wood, fiberglass)
	Special	Check for adjacent units or building fresh air intakes within 10-ft of this unit's flue outlet

NOTE: Unit not designed to have overhead obstruction. Contact Application Engineering for guidance on any application planning overhead obstruction or vertical clearances.

CURBS, WEIGHTS & DIMENSIONS (cont.)

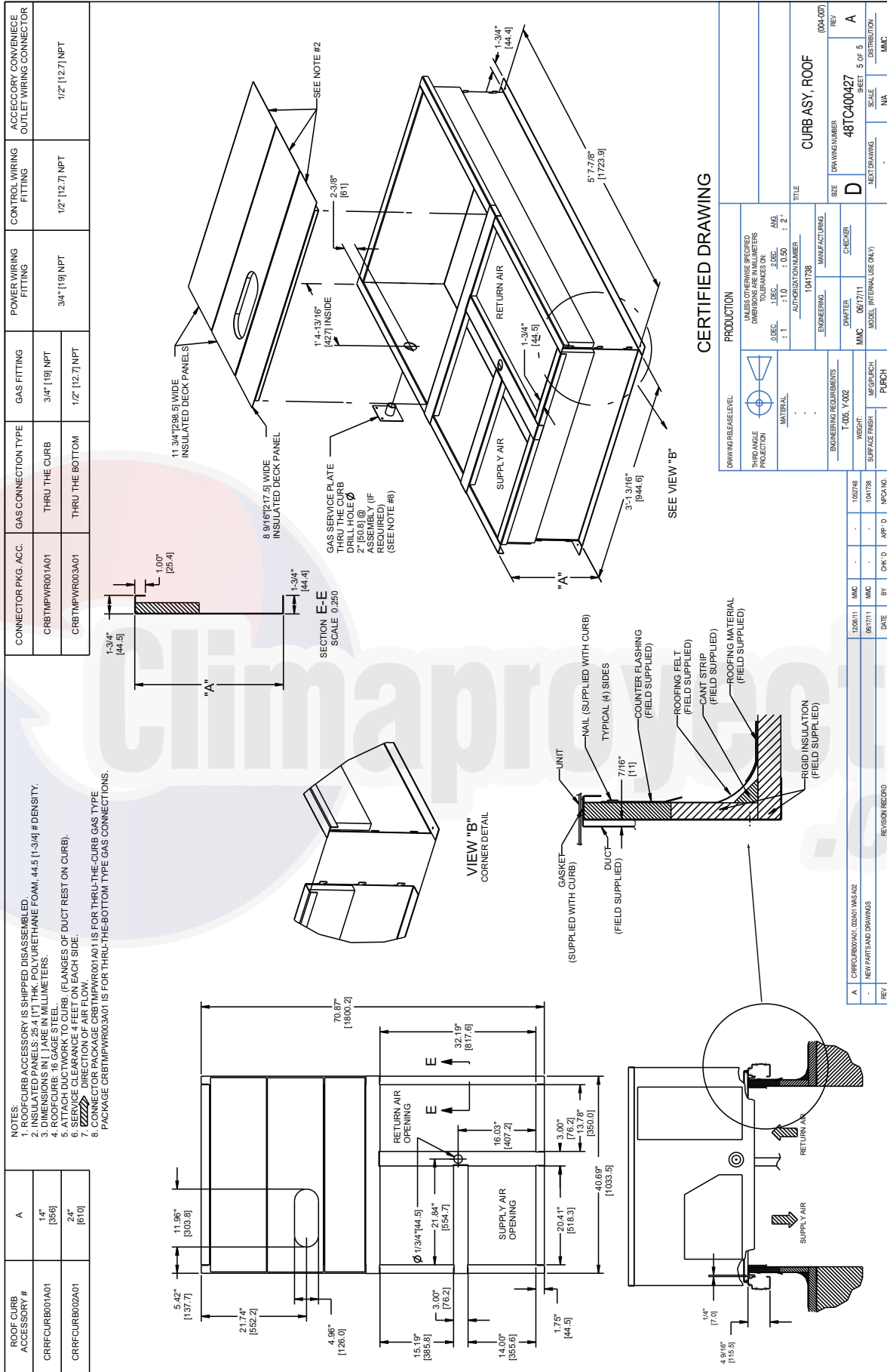

Fig. 4 - Roof Curb Details - 48TC 04-07

CURBS, WEIGHTS & DIMENSIONS (cont.)

NOTES:

1. DIMENSIONS ARE IN INCHES, DIMENSIONS IN () ARE IN MILLIMETERS.
2. CENTER OF GRAVITY
3. DIRECTION OF AIR FLOW

CONNECTION SIZES	
A	1 3/8" DIA [35] FIELD POWER SUPPLY HOLE
B	2 1/2" [64] DIA POWER SUPPLY KNOCKOUT
C	1 3/4" DIA [51] GAUGE ACCESS PLUG
D	7/8" DIA [22] FIELD CONTROL WIRING HOLE
E	3/4"-14 NPT CONDENSATE DRAIN
F	1/2"-14 NPT GAS CONNECTION 3/4"-14 NPT GAS CONNECTION
G	2" DIA [51] POWER SUPPLY KNOCK-OUT

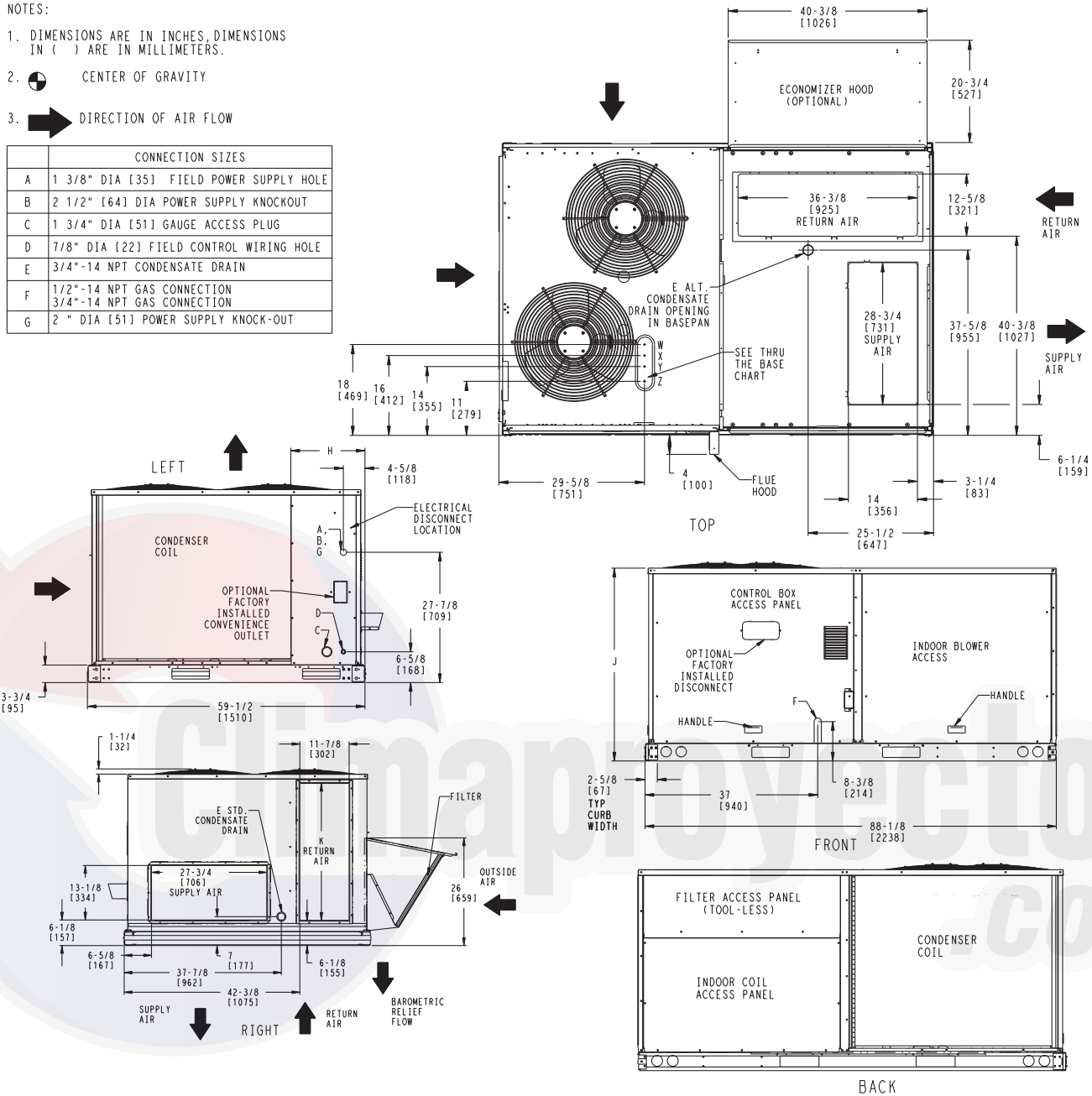

UNIT	OUTDOOR COIL TYPE	J	K	H
48TC-A08	RTPF	41 1/4 [1048]	33 [658]	15 7/8 [403]
48TC-A09	RTPF	49 3/8 [1253]	37 1/4 [946]	27 7/8 [708]
48TC-A12	RTPF	49 3/8 [1253]	37 1/4 [946]	15 7/8 [403]
48TC-D08	RTPF	41 1/4 [1048]	33 [658]	15 7/8 [403]
48TC-D09	RTPF	49 3/8 [1253]	37 1/4 [946]	15 7/8 [403]
48TC-D12	RTPF	49 3/8 [1253]	37 1/4 [946]	15 7/8 [403]
48TC-D08	MCHX	41 1/4 [1048]	33 [658]	23 [584.2]
48TC-D12	MCHX	49 3/8 [1253]	37 1/4 [946]	11 [279.4]

RTPF - ROUND TUBE, PLATE FIN (COPPER/ALUM)
MCHX - NOVATION (ALUM/ALUM)

THRU-THE-BASE CHART (FIELD INST)

THESE HOLES REQUIRED FOR USE WITH ACCY KITS:
CRBTMPWR002A01: GAS THRU CURB
CRBTMPWR004A01: GAS THRU BASEPAN

	THREADED CONDUIT SIZE	WIRE USE	REQ'D HOLE SIZES (MAX.)
W	1/2"	ACC.	7/8" [22.2]
X	1/2"	24V	7/8" [22.2]
Y	1 1/4" (002,004)	POWER	1 3/4" [44.4]
Z *	(004) 3/4" FPT	GAS	1 3/4" [44.4]
*	(002) PROVIDES 3/4" FPT THRU CURB FLANGE & FITTING.		HOLE SIZE: 2" [50.8]

THRU-THE-BASE CHART (FIOP)

FOR "THRU-THE-BASEPAN" FACTORY OPTION, FITTINGS FOR ONLY X, Y, & Z ARE PROVIDED. **

** FOR BELOW LISTED MODELS, A FIELD SUPPLIED 1/2" ADAPTER IS REQUIRED BETWEEN BASE PAN FITTING AND GAS VALVE: 48TCD, S*08, 09

Fig. 5 - Dimensions 48TC 08-12

CURBS, WEIGHTS & DIMENSIONS (cont.)

UNIT	OUTDOOR COIL TYPE	STD. UNIT WEIGHT		CORNER WEIGHT (A)		CORNER WEIGHT (B)		CORNER WEIGHT (C)		CORNER WEIGHT (D)		C.G.		
		LBS.	KG.	LBS.	KG.	LBS.	KG.	LBS.	KG.	LBS.	KG.	X	Y	Z
48TC-A08	RTPF	780	354	178	81	158	72	209	95	236	107	41 1/2 [1054]	33 7/8 [860]	20 1/2 [521]
48TC-A09	RTPF	920	418	212	96	183	83	243	110	282	128	40 7/8 [1038]	34 [864]	23 1/8 [587]
48TC-A12	RTPF	930	422	216	98	196	89	247	112	272	123.5	42 [1067]	33 1/8 [841]	24 1/4 [616]
48TC-D08	RTPF	835	379	164	74.5	170	77.2	255	115.8	246	111.7	44 7/8 [1140]	35 5/8 [905]	19 3/8 [492]
48TC-D09	RTPF	930	422	228	103.5	187	85	232	105.3	283	128.5	39 3/4 [1010]	32 7/8 [835]	18 5/8 [473]
48TC-D12	RTPF	940	427	231	104.9	189	85.8	234	106.2	286	129.8	39 3/4 [1010]	33 [838]	18 1/2 [470]
48TC-D08	MCHX	805	365.5	160	72.6	153	69.5	240	109	260	118	43 [1092]	36 3/8 [924]	20 3/8 [517.7]
48TC-D12	MCHX	895	406.3	185	84	176	79.9	260	118	274	124.4	42 7/8 [1089]	35 1/2 [902]	22 7/8 [581]

RTPF - ROUND TUBE, PLATE FIN (COPPER/ALUM)
MCHX - NOVATION (ALUM/ALUM)

*** STANDARD UNIT WEIGHT IS WITH LOW GAS HEAT AND WITHOUT PACKAGING. FOR OTHER OPTIONS AND ACCESSORIES, REFER TO THE PRODUCT DATA CATALOG.

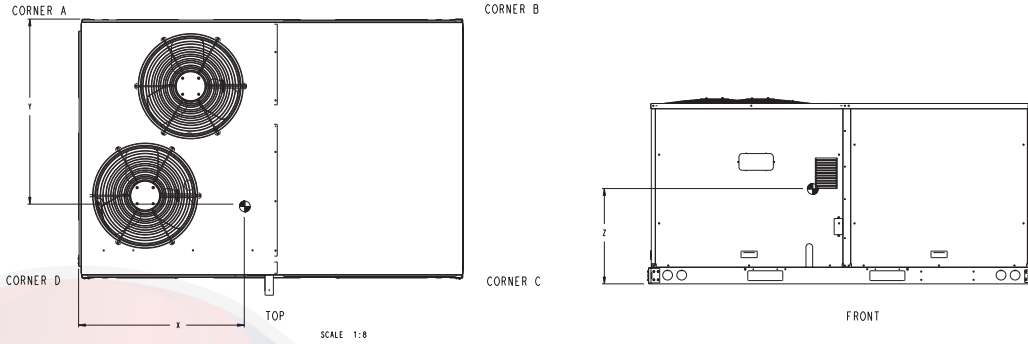

Fig. 6 - 48TC 08-12

C10299

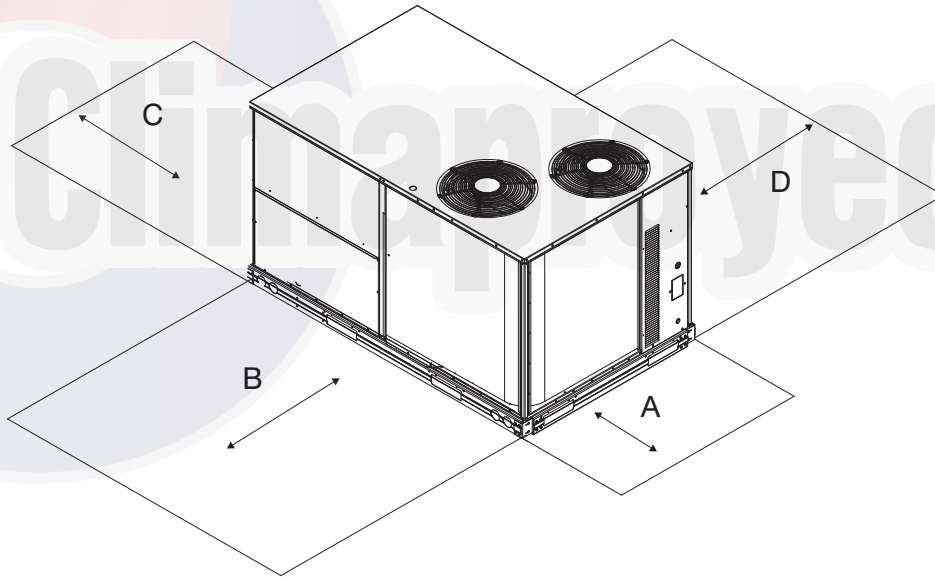

Fig. 7 - Service Clearance

C11247

LOC	DIMENSION	CONDITION
A	48-in (1219 mm)	Unit disconnect is mounted on panel
	36-in (914 mm)	If dimension - B is 12-in (305 mm)
	18-in (457 mm)	No disconnect, convenience outlet option
	18-in (457 mm)	Recommended service clearance (use electric screwdriver)
	12-in (305 mm)	Minimum clearance (use manual ratchet screwdriver)
B	36-in (914 mm)	Unit has economizer
	12-in (305 mm) Special	If dimension - A is 36-in (914 mm) Check for sources of flue products within 10-ft of unit fresh air intake hood
C	36-in (914 mm)	Side condensate drain is used
	18-in (457 mm)	Minimum clearance
D	48-in (1219 mm)	No flue discharge accessory installed, surface is combustible material
	42-in (1067 mm)	Surface behind servicer is grounded (e.g., metal, masonry wall, another unit)
	36-in (914 mm)	Surface behind servicer is electrically non-conductive (e.g., wood, fiberglass)
	Special	Check for adjacent units or building fresh air intakes within 10-ft of this unit's flue outlet

NOTE: Unit not designed to have overhead obstruction. Contact Application Engineering for guidance on any application planning overhead obstruction or vertical clearances.

CURBS, WEIGHTS & DIMENSIONS (cont.)

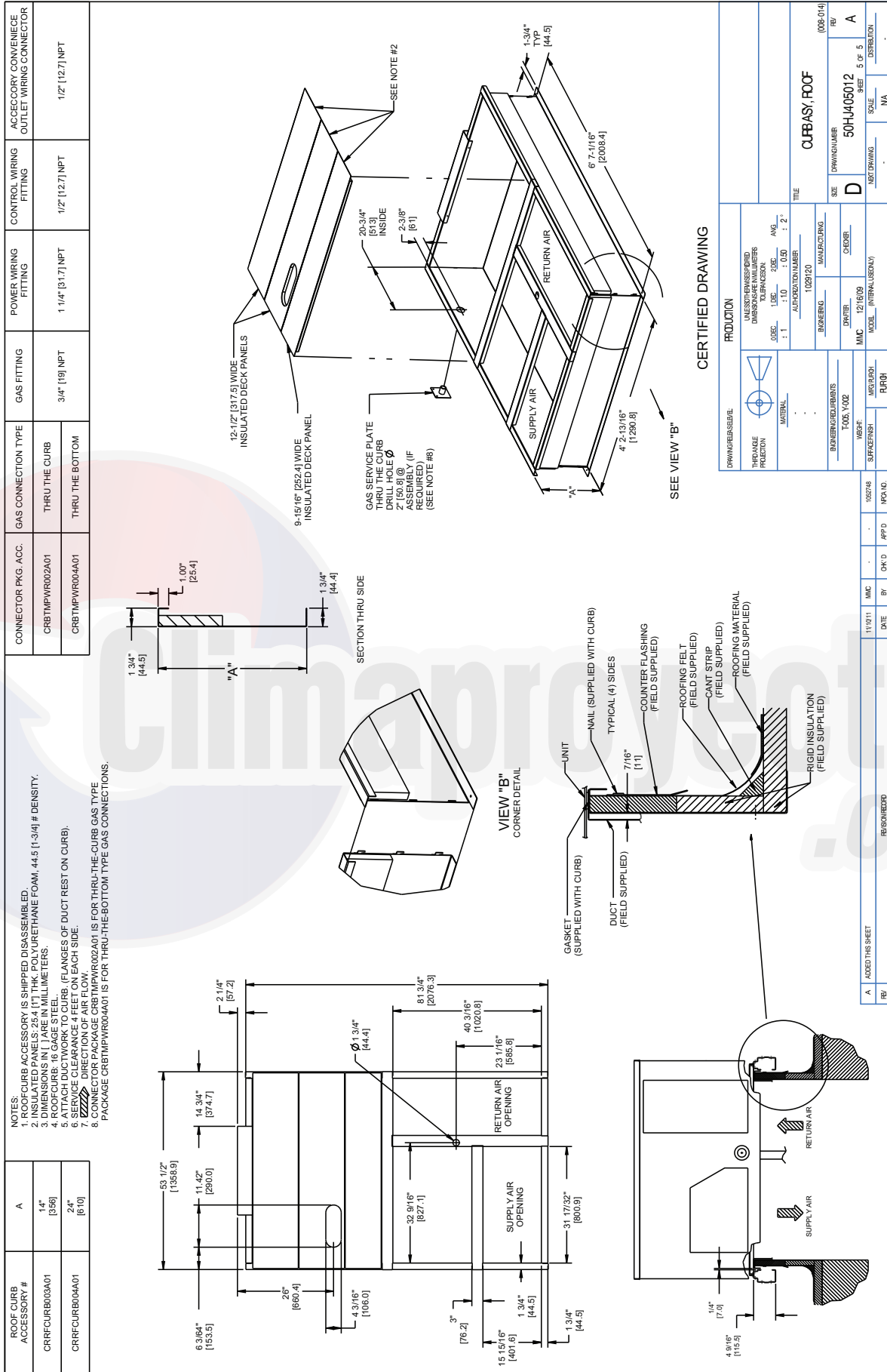

PRODUCTION	
UNLESS OTHERWISE SPECIFIED DIMENSIONS ARE IN MILLIMETERS	ANG.
DEC. 1.00	20C.
1.1	1.2
MATERIAL	
1029120	
MANUFACTURING	
DRAWING NUMBER	
50HJ405012	
TITLE	
CURB ASY, ROOF	
DRAWING NUMBER	
D	
SCALE	
5 OF 5	
CORRECTION	
(008.014)	
REV	
A	

DRAWING REVISION	PRODUCTION	DATE	BY
UNLESS OTHERWISE SPECIFIED DIMENSIONS ARE IN MILLIMETERS	UNLESS OTHERWISE SPECIFIED DIMENSIONS ARE IN MILLIMETERS	12/18/08	1029120
DEC. 1.00	20C.	1.00	1.2
1.1	1.2	1.00	1.2
MATERIAL		MANUFACTURING	
1029120		DRAWING NUMBER	
50HJ405012		TITLE	
CURB ASY, ROOF		DRAWING NUMBER	
D		SCALE	
5 OF 5		CORRECTION	
(008.014)		REV	
A		A	

ADDED THIS SHEET	REVISION	DATE	BY
11/07/11	1029120	11/07/11	1029120
11/07/11	1029120	11/07/11	1029120
11/07/11	1029120	11/07/11	1029120
11/07/11	1029120	11/07/11	1029120
11/07/11	1029120	11/07/11	1029120
11/07/11	1029120	11/07/11	1029120
11/07/11	1029120	11/07/11	1029120
11/07/11	1029120	11/07/11	1029120
11/07/11	1029120	11/07/11	1029120

Fig. 8 - Roof Curb Details 48TC 08-14

CURBS, WEIGHTS & DIMENSIONS (cont.)

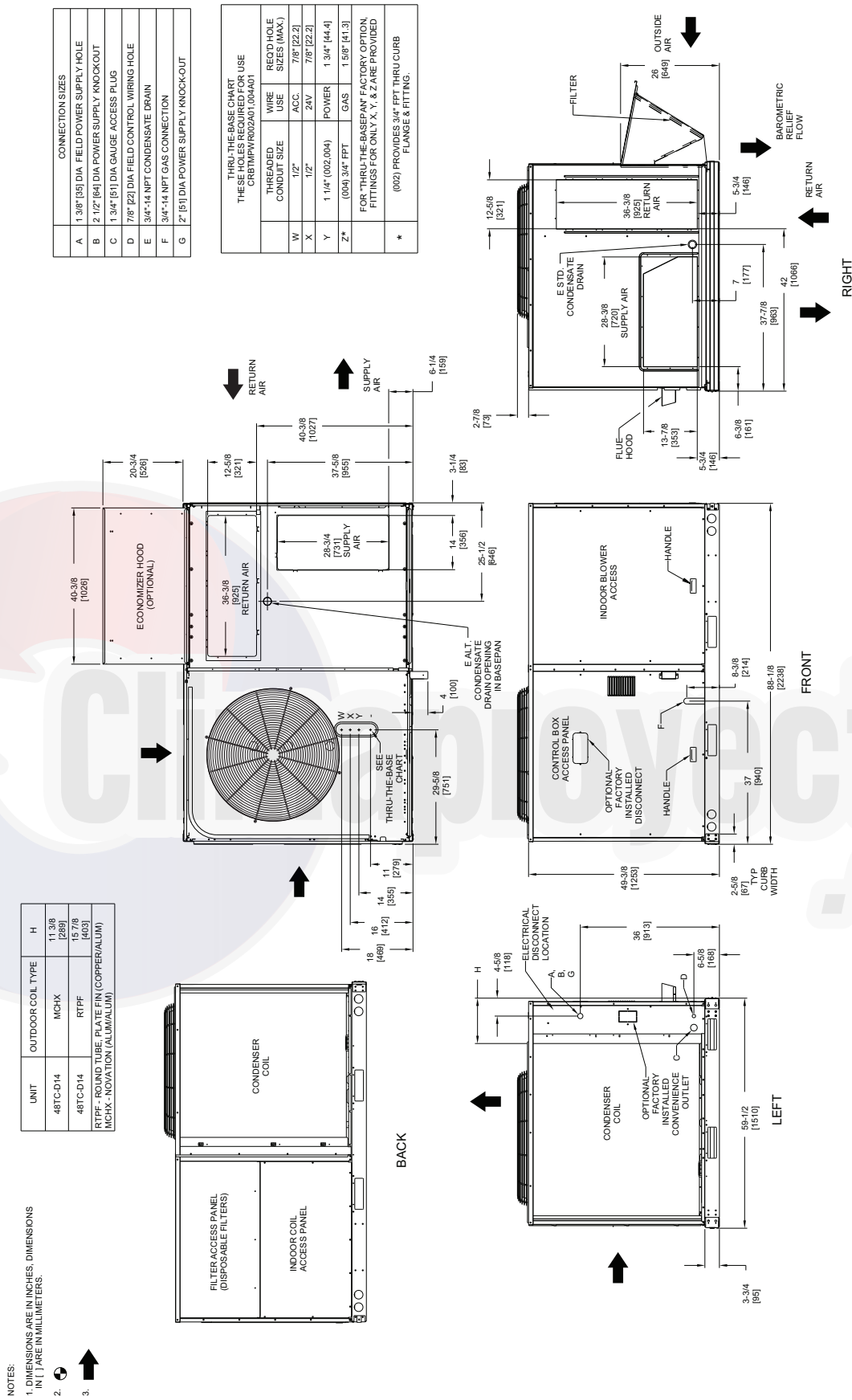

Fig. 9 - Dimensions 48TC 14

CURBS, WEIGHTS & DIMENSIONS (cont.)

UNIT	OUTDOOR COIL TYPE	STD. UNIT WEIGHT***		CORNER WEIGHT (A)		CORNER WEIGHT (B)		CORNER WEIGHT (C)		CORNER WEIGHT (D)		C.G.		
		LBS.	KG.	LBS.	KG.	LBS.	KG.	LBS.	KG.	LBS.	KG.	X	Y	Z
48TC-D14	MCHX	1116	506	297	135	157	71	229	104	434	197	29 1/2 [749]	34 1/4 [870]	20 1/4 [514]
48TC-D14	RTPF	1167	530	349	159	167	76	211	96	440	200	31 3/8 [797]	34 3/4 [883]	21 7/8 [556]

RTPF - ROUND TUBE, PLATE FIN (COPPER/ALUM)
MCHX - MICROCHANNEL (ALUM/ALUM)

*STANDARD UNIT WEIGHT IS WITH LOW HEAT & WITHOUT PACKAGING.
FOR OPTIONS & ACCESSORIES, REFER TO THE PRODUCT DATA CATALOG.

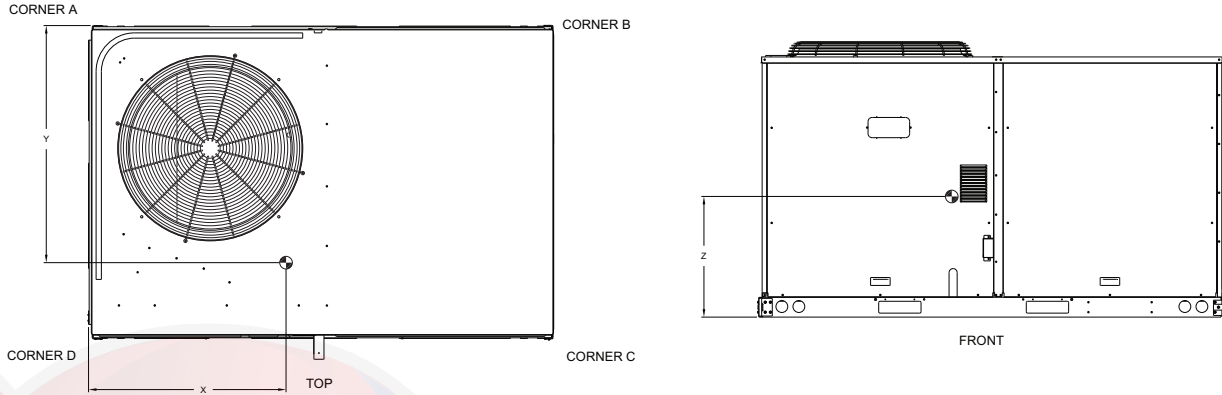

Fig. 10 - Dimensions 48TC 14

A10487A

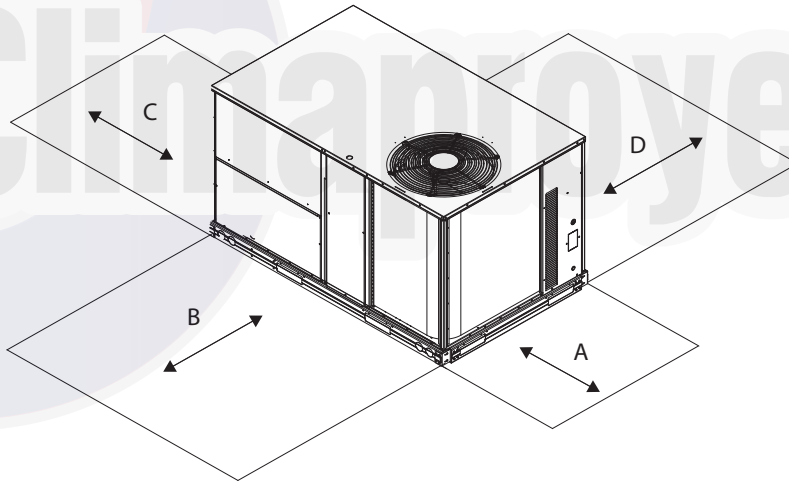

Fig. 11 - Service Clearance

C08337

LOC	DIMENSION	CONDITION
A	48-in (1219 mm)	Unit disconnect is mounted on panel
	36-in (914 mm)	If dimension-B is 12-in (305 mm)
	18-in (457 mm)	No disconnect, convenience outlet option
	18-in (457 mm)	Recommended service clearance (use electric screwdriver)
	12-in (305 mm)	Minimum clearance (use manual ratchet screwdriver)
B	36-in (914 mm)	Unit has economizer
	12-in (305 mm)	If dimension-A is 36-in (914 mm)
	Special	Check for sources of flue products within 10-ft of unit fresh air intake hood
C	36-in (914 mm)	Side condensate drain is used
	18-in (457 mm)	Minimum clearance
D	48-in (1219 mm)	No flue discharge accessory installed, surface is combustible material
	42-in (1067 mm)	Surface behind servicer is grounded (e.g., metal, masonry wall, another unit)
	36-in (914 mm)	Surface behind servicer is electrically non-conductive (e.g., wood, fiberglass)
	Special	Check for adjacent units or building fresh air intakes within 10-ft of this unit's flue outlet

NOTE: Unit not designed to have overhead obstruction. Contact Application Engineering for guidance on any application planning overhead obstruction or vertical clearances.

CURBS, WEIGHTS & DIMENSIONS (cont.)

NOTES:

1. DIMENSIONS ARE IN INCHES, DIMENSIONS IN [] ARE IN MILLIMETERS.
2. CENTER OF GRAVITY
3. DIRECTION OF AIR FLOW

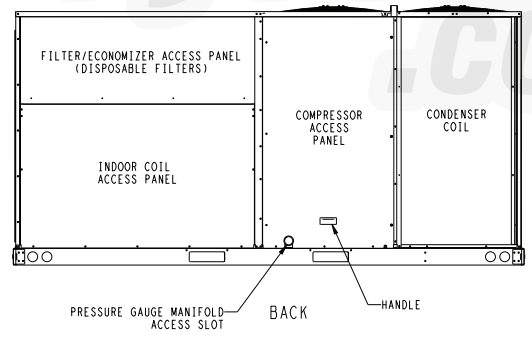
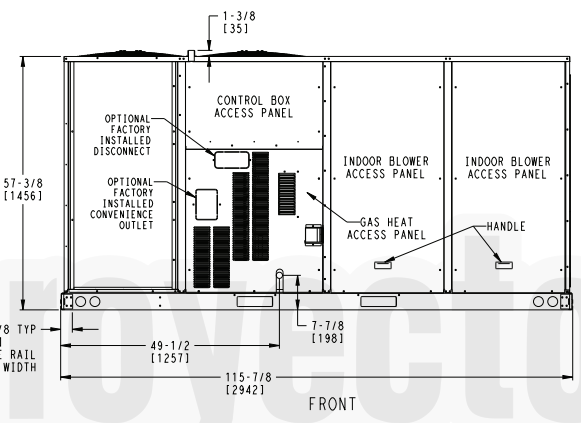
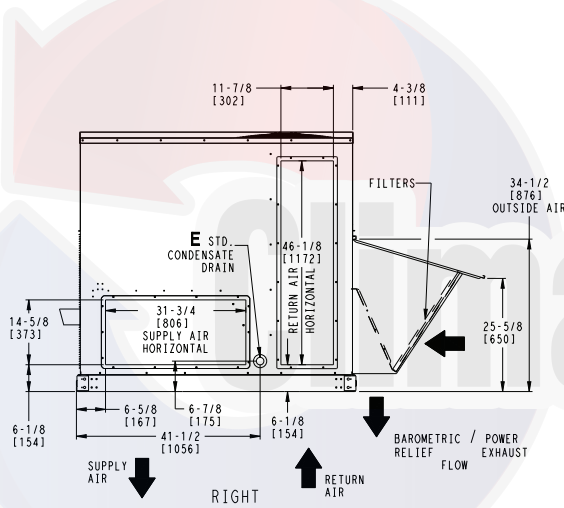
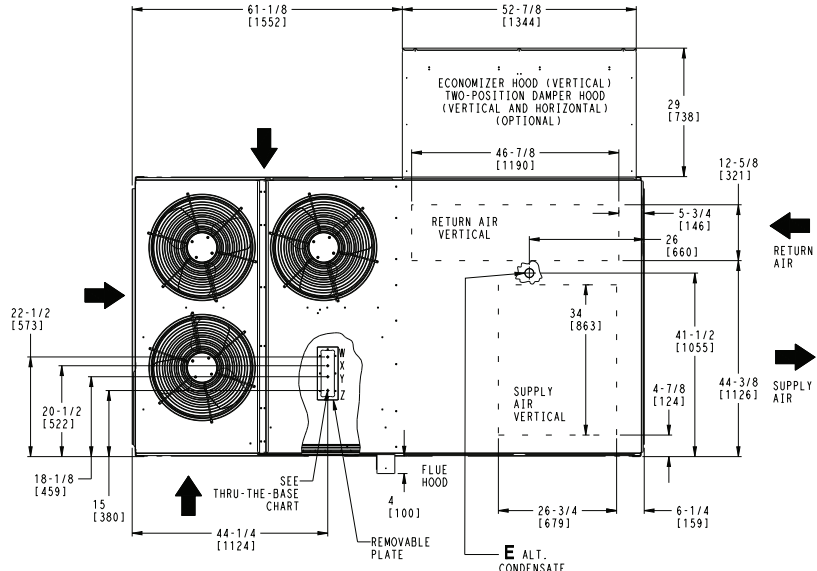
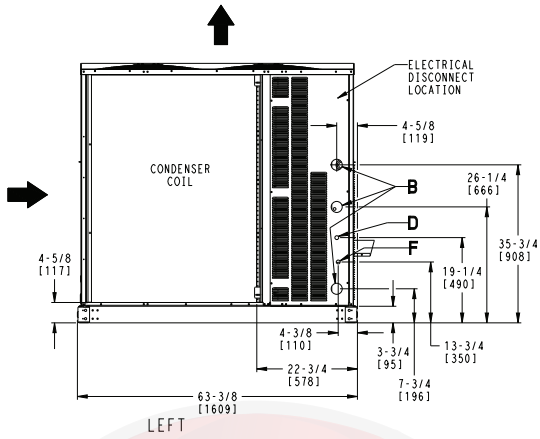

THRU-THE-BASE CHART THESE HOLES REQUIRED FOR USE CRBTMPWR005A00, 006A00, 007A00			
ACCESSORY NO.	THREADED CONDUIT SIZE	WIRE USE	REQ'D HOLE SIZES (MAX.)
005	W 1/2"	ACC.	7/8" [22.2]
	X 1/2"	24V	7/8" [22.2]
	Y 1 1/4"	POWER	1 1/2" [38.1]
	Z 3/4" PIPE	GAS	1 3/4" [44.5]
006	W 1/2"	ACC.	7/8" [22.2]
	X 1/2"	24V	7/8" [22.2]
	Y 1 1/2"	POWER	2" [50.8]
	Z 3/4" PIPE	GAS	1 3/4" [44.5]
007	W 1/2"	ACC.	7/8" [22.2]
	X 1/2"	24V	7/8" [22.2]
	Y 2"	POWER	2 1/2" [63.5]
	Z 3/4" PIPE	GAS	1 3/4" [44.5]
FOR "THRU-THE-BASEPAN" FACTORY OPTION, FITTINGS FOR X & Y ARE PROVIDED AS SPECIFIED ON "006".			

CONNECTION SIZES	
B	2 1/2" [64] DIA POWER SUPPLY HOLE
D	7/8" [22] DIA FIELD CONTROL WIRING HOLE
E	3/4"-14 NPT CONDENSATE DRAIN
F	7/8" [22] DIA FIELD CONVENIENCE OUTLET HOLE

Fig. 12 - Dimensions 48TC 16

A10488

CURBS, WEIGHTS & DIMENSIONS (cont.)

UNIT	STD UNIT WEIGHT*		CORNER WEIGHT (A)		CORNER WEIGHT (B)		CORNER WEIGHT (C)		CORNER WEIGHT (D)		C.G.		
	LBS.	KG.	LBS.	KG.	LBS.	KG.	LBS.	KG.	LBS.	KG.	X	Y	Z
48TC-D16	1380	627	295	134	276	126	342	156	421	191	64 1/4 [1630]	35 [890]	21 1/8 [537]

*STANDARD UNIT WEIGHT IS WITH LOW HEAT & WITHOUT PACKAGING.
FOR OPTIONS & ACCESSORIES, REFER TO THE PRODUCT DATA CATALOG.

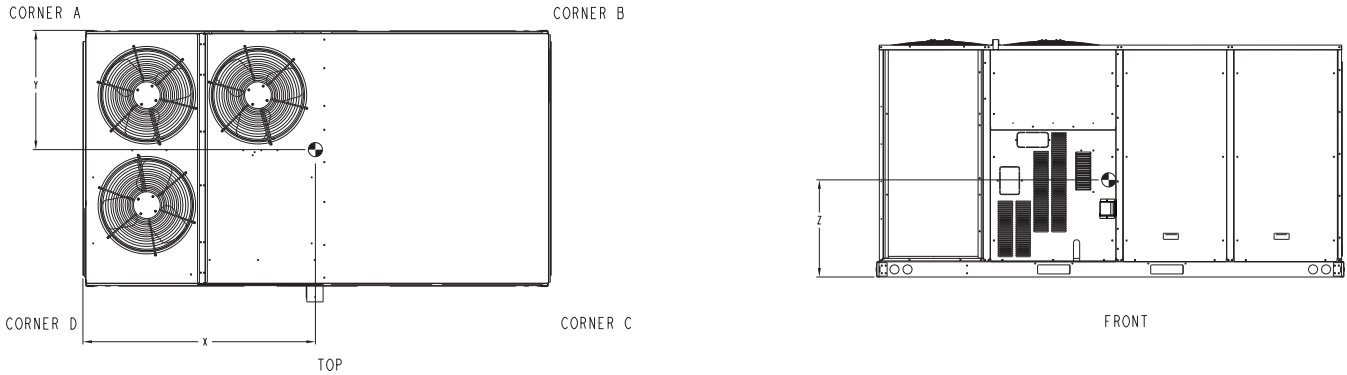

Fig. 13 - Dimensions 48TC 16

C10862B

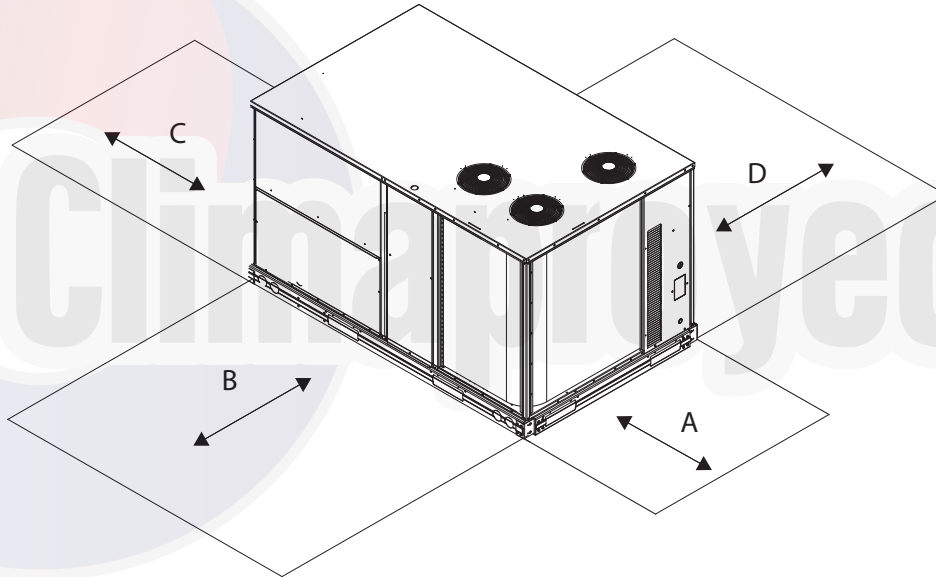

Fig. 14 - Service Clearance

C10578B

LOC	DIMENSION	CONDITION
A	48-in (1219 mm)	Unit disconnect is mounted on panel
	18-in (457 mm)	No disconnect, convenience outlet option
	18-in (457 mm)	Recommended service clearance
	12-in (305 mm)	Minimum clearance
B	42-in (1067 mm)	Surface behind servicer is grounded (e.g., metal, masonry wall)
	36-in (914 mm) Special	Surface behind servicer is electrically non-conductive (e.g., wood, fiberglass) Check for sources of flue products within 10-ft of unit fresh air intake hood
C	36-in (914 mm)	Side condensate drain is used
	18-in (457 mm)	Minimum clearance
D	48-in (1219 mm)	No flue discharge accessory installed, surface is combustible material
	42-in (1067 mm)	Surface behind servicer is grounded (e.g., metal, masonry wall, another unit)
	36-in (914 mm)	Surface behind servicer is electrically non-conductive (e.g., wood, fiberglass)
	Special	Check for adjacent units or building fresh air intakes within 10-ft of this unit's flue outlet

NOTE: Unit not designed to have overhead obstruction. Contact Application Engineering for guidance on any application planning overhead obstruction or vertical clearances.

CURBS, WEIGHTS & DIMENSIONS (cont.)

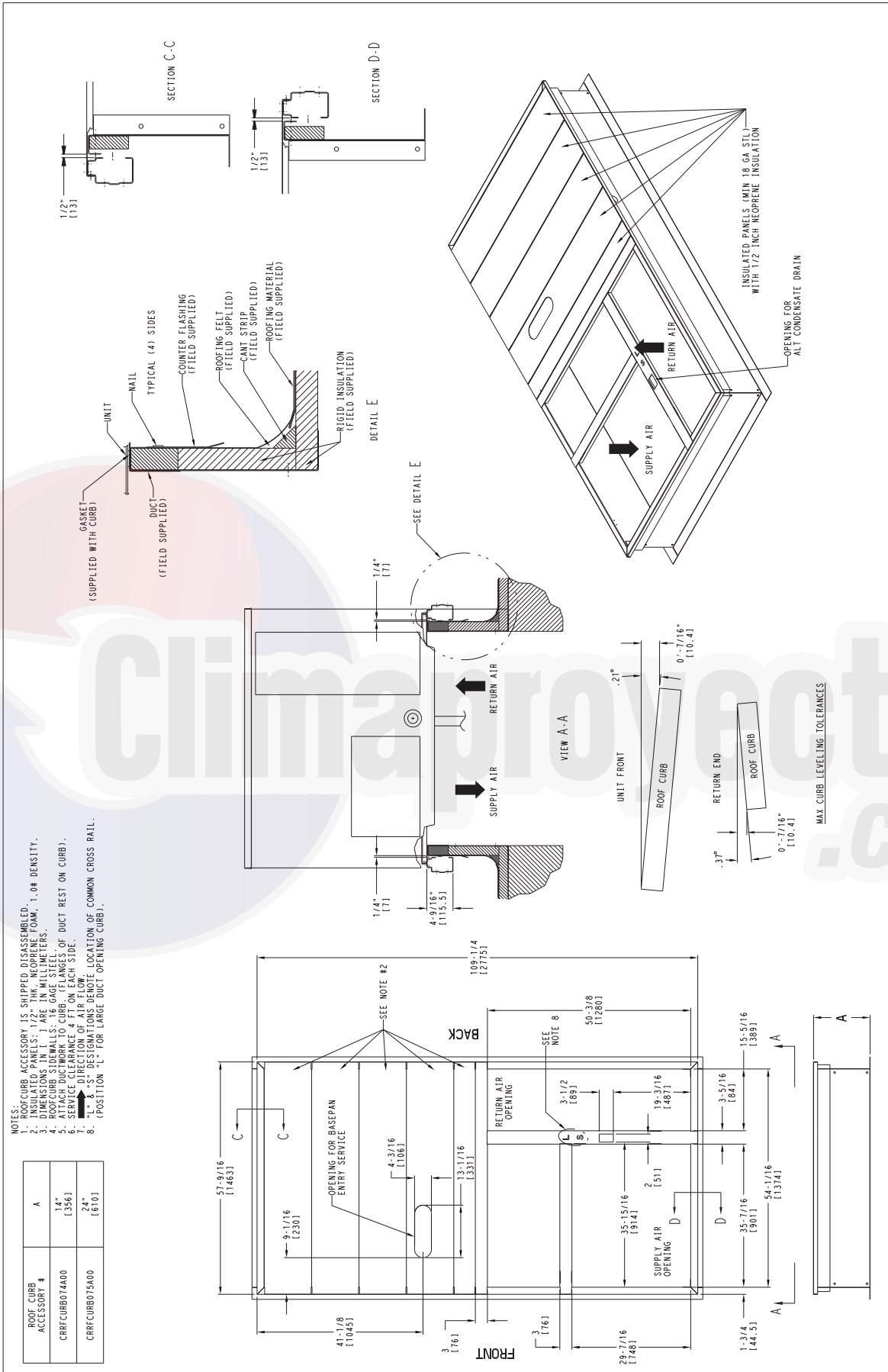

Fig. 15 - Roof Curb Details 48TC 16

OPTIONS & ACCESSORY WEIGHTS

OPTION / ACCESSORY	OPTION / ACCESSORY WEIGHTS																	
	04		05		06		07		08		09		12		14		16	
	lb	kg	lb	kg	lb	kg	lb	kg	lb	kg	lb	kg	lb	kg	lb	kg	lb	kg
Humidi-MiZer ¹	15	7	23	10	25	11	29	13	38	17	47	21	47	21	47	21	57	26
Power Exhaust – vertical	50	23	50	23	50	23	50	23	75	34	75	34	75	34	75	34	85	39
Power Exhaust – horizontal	30	14	30	14	30	14	30	14	30	14	30	14	30	14	30	14	75	34
EconoMiSer(IV, X or 2)	50	23	50	23	50	23	50	23	75	34	75	34	75	34	75	34	115	52
Two Position damper	39	18	39	18	39	18	39	18	58	26	58	26	58	26	58	26	65	29
Manual Dampers	12	5	12	5	12	5	12	5	18	8	18	8	18	8	18	8	25	11
Medium Gas Heat	12	5	9	4	9	4	9	4	15	7	15	7	18	8	18	8	28	13
High Gas Heat	–	–	17	8	17	8	17	8	29	13	29	13	35	16	35	16	50	23
Hail Guard (louvered)	16	7	16	7	16	7	16	7	34	15	34	15	34	15	34	15	45	20
Cu/Cu Condenser Coil ²	6	3	13	6	13	6	15	7	12	5	23	10	23	10	23	10	190	86
Cu/Cu Condenser and Evaporator Coils ²	12	5	19	9	21	10	26	12	25	11	49	22	49	22	49	22	280	127
Roof Curb (14–in. curb)	115	52	115	52	115	52	115	52	143	65	143	65	143	65	143	65	180	82
Roof Curb (24–in. curb)	197	89	197	89	197	89	197	89	245	111	245	111	245	111	245	111	255	116
CO ₂ sensor	5	2	5	2	5	2	5	2	5	2	5	2	5	2	5	2	5	2
Flue Discharge Deflector	7	3	7	3	7	3	7	3	7	3	7	3	7	3	7	3	–	–
Optional Indoor Motor/Drive	10	5	10	5	10	5	10	5	15	7	15	7	15	7	15	7	45	20
Motor Master Controller	35	16	35	16	35	16	35	16	35	16	35	16	35	16	40	18	40	18
Return Smoke Detector	5	2	5	2	5	2	5	2	5	2	5	2	5	2	5	2	5	2
Supply Smoke Detector	5	2	5	2	5	2	5	2	5	2	5	2	5	2	5	2	5	2
Non–Fused Disconnect	15	7	15	7	15	7	15	7	15	7	15	7	15	7	15	7	15	7
Powered Convenience outlet	35	16	35	16	35	16	35	16	35	16	35	16	35	16	35	16	35	16
Non–Powered Convenience outlet	5	2	5	2	5	2	5	2	5	2	5	2	5	2	5	2	5	2
Enthalpy Sensor	2	1	2	1	2	1	2	1	2	1	2	1	2	1	2	1	2	1
Differential Enthalpy Sensor	3	1	3	1	3	1	3	1	3	1	3	1	3	1	3	1	3	1
SAV System with VFD	–	–	–	–	–	–	–	–	20	9	20	9	20	9	20	9	20	9

NOTE: Where multiple variations are available, the heaviest combination is listed.

– Not Available

¹ For Humidi–MiZer add MotorMaster Controller.

² Where available.

APPLICATION DATA

Min operating ambient temp (cooling):

In mechanical cooling mode, your Carrier rooftop unit can safely operate down to an outdoor ambient temperature of 40°F (4°C) and 25°F (-4°C), with an accessory winter start kit. It is possible to provide cooling at lower outdoor ambient temperatures by using less outside air, economizers, and/or accessory low ambient kits.

Max operating ambient temp (cooling):

The maximum operating ambient temperature for cooling mode is 115°F (46°C). While cooling operation above 115°F (46°C) may be possible, it could cause either a reduction in performance, reliability, or a protective action by the unit's internal safety devices.

Min mixed air temp (heating):

Using the factory settings, the minimum temperatures for the mixed air (the combined temperature of the warm return air and the cold outdoor air) entering the dimpled, gas heat exchangers are:

<u>Aluminized</u>	<u>Stainless Steel</u>
50°F (10°C) continuous	40°F (4°C) continuous
45°F (7°C) intermittent	35°F (2°C) intermittent

Operating at lower mixed-air temperatures may be possible, if a field supplied, outdoor air thermostat initiates both heat stages when the temperature is less than the minimum temperatures listed above. Please contact your local Carrier representative for assistance.

Min and max airflow (heating and cooling):

To maintain safe and reliable operation of your rooftop, operate within the heating airflow limits during heating mode and cooling airflow limits during cooling mode. Operating above the max may cause blow-off, undesired airflow noise, or airflow related problems with the rooftop unit. Operating below the min may cause problems with coil freeze-up and unsafe heating operation. Heating and cooling limitations differ when evaluating operating cfm, the minimum value is the HIGHER of the cooling and heating minimum cfm values published in Table 6 and the maximum value is the LOWER of the cooling and heating maximum values published in Table 6.

Heating-to-cooling changeover:

Your unit will automatically change from heating to cooling mode when using a thermostat with an auto-changeover feature.

Airflow:

All units are draw-through in cooling mode and blow-through in heating mode.

Outdoor air application strategies:

Economizers reduce operating expenses and compressor run time by providing a free source of cooling and a means of ventilation to match application changing needs. In fact, they should be considered for most applications. Also, consider the various economizer control methods and their benefits, as well as sensors required to accomplish your application goals. Please contact your local Carrier representative for assistance.

Motor limits, Brake horsepower (BHP):

Due to internal design of Carrier units, the air path, and specially designed motors, the full horsepower (maximum continuous BHP) band, as listed in Table 8 and 10, can be used with the utmost confidence. There is no need for extra safety factors, as Carrier motors are designed and rigorously tested to use the entire, listed BHP range without either nuisance tripping or premature motor failure.

Propane heating:

Propane has different physical qualities than natural gas. As a result, propane requires different fuel to air mixture. To optimize the fuel/air mixture for propane, Carrier sells different burner orifices in an easy to install accessory kit. To select the correct burner orifices or determine the heat capacity for a propane application, use either the selection software, or the unit's service manual.

High altitude heating:

High altitudes have less oxygen, which affects the fuel/air mixture in heat exchangers. In order to maintain a proper fuel/air mixture, heat exchangers operating in altitudes above 2000 ft (610 m) require different orifices. To select the correct burner orifices or determine the heat capacity for a high altitude application, use either the selection software, or the unit's service manual.

High altitudes have less oxygen, which means heat exchangers need less fuel. The new gas orifices in this field installed kit make the necessary adjustment for high altitude applications. They restore the optimal fuel to air mixture and maintain healthy combustion on altitudes above 2000 ft (610 m).

NOTE: Typical natural gas heating value ranges from 975 to 1050 Btu/ft³ at sea level nationally. The heating value goes down approximately 1.7% per every thousand feet elevation. Standard factory orifices can typically be used up to 2000 ft (610m) elevation without any operational issues.

NOTE: For installations in Canada, the input rating should be derated by 10% for altitudes from 2000 ft (610m) to 4500 ft (1372m) above sea level.

APPLICATION DATA (cont.)

Sizing a rooftop

Bigger isn't necessarily better. While an air conditioner needs to have enough capacity to meet the design loads, it doesn't need excess capacity. In fact, excess capacity typically results in very poor part load performance and humidity control.

Using higher design temperatures than ASHRAE recommends for your location, adding "safety factors" to the calculated load, are all signs of oversizing air conditioners. Oversizing the air conditioner leads to poor humidity control, reduced efficiency, higher utility bills, larger indoor temperature swings, excessive noise, and increased wear and tear on the air conditioner.

Rather than oversizing an air conditioner, engineers should "right size" or even slightly undersize air conditioners. Correctly sizing an air conditioner controls humidity better; promotes efficiency; reduces utility bills; extends equipment life, and maintains even, comfortable temperatures. Please contact your local Carrier representative for assistance.

Low ambient applications

The optional Carrier economizer can adequately cool your space by bringing in fresh, cool outside air. In fact, when so equipped, accessory low ambient kit may not be necessary. In low ambient conditions, unless the outdoor air is excessively humid or contaminated, economizer based "free cooling" is the preferred less costly and energy conscious method.

In low ambient applications where outside air might not be desired (such as contaminated or excessively humid outdoor environments), your Carrier rooftop can operate at ambient temperatures down to -20°F (-29°C) using the recommended accessory Motormaster low ambient controller.

Staged Air Volume (SAV) with Variable Frequency Drive (VFD)

Carrier's Staged Air Volume (SAV) system utilizes a Variable Frequency Drive (VFD) to automatically adjust the indoor fan motor speed in sequence with the units cooling operation. Per ASHRAE 90.1 2010 standard section 6.4.3.10.b, during the first stage of cooling operation the VFD will adjust the fan motor to provide 2/3rd of the total cfm established for the unit. When a call for the second stage of cooling is required, the VFD will allow the total cfm for the unit established (100%). During the heating mode, the VFD will allow total design cfm (100%) operation and during the ventilation mode the VFD will allow operation to 2/3rd of total cfm.

The VFD used in Carrier's SAV system has soft start capabilities to slowly ramp up the speeds, thus eliminating any high inrush air volume during initial start-up. It also has internal over current protection for the fan motor and a field installed display kit that allows adjustment and in depth diagnostics of the VFD.

This SAV system is available on models with 2-stage cooling operation with electrical mechanical or RTU Open (multi Protocol) controls. Both space sensor and conventional thermostats/controls can be used to provide accurate control in any application.

The SAV system is very flexible for initial fan performance set up and adjustment. The standard factory shipped VFD is pre programmed to automatically stage the fan speed between the first and second stage of cooling. The unit fan performance static pressure and cfm can be easily adjusted using the traditional means of pulley adjustments. The other means to adjust the unit static and cfm performance is to utilize the field installed display module and adjust the frequency and voltage in the VFD to required performance requirements. In either case, once set up the VFD will automatically adjust the speed between the cooling stage operation.

SELECTION PROCEDURE (WITH 48TC*A07 EXAMPLE)¹

I. Determine cooling and heating loads.

Given:

Mixed air dry bulb	80°F (27°C)
Mixed air wet bulb	67°F (19°C)
Ambient dry bulb	95°F (35°C)
TC _{Load}	72.0 MBH
SHC _{Load}	54.0 MBH
Vertical supply air	2100 CFM
Heating load	85.0 MBH
External static pressure	0.67 in. wg
Electrical characteristics	230-3-60

II. Make an initial guess at cooling tons.

Refrig. tons = TC_{Load} / 12 MBH per ton
 Refrig. tons = 72.0 / 12 = 6.0 tons
 In this case, start by looking at the 48TC*A07.

III. Look up the rooftop's TC and SHC.

Table 19 shows that, at the application's supply air CFM, mixed air and ambient temperatures, the 48TC*A07 supplies:
 TC = 73.7 MBH²
 SHC = 54.4 MBH²

IV. Calculate the building latent heat load.

LC_{Load} = TC_{Load} - SHC_{Load}
 LC_{Load} = 72.0 MBH - 54.0 MBH = 18.0 MBH

V. Calculate RTU latent heat capacity.

LC = TC - SHC
 LC = 73.7 MBH - 54.4 MBH = 19.3 MBH

VI. Compare RTU capacities to loads.³

Compare the rooftop's SHC and LC to the building's sensible and latent heat loads.

Legend

BHP	— Brake horsepower
FLA	— Full load amps
LC	— Latent capacity
LRA	— Lock rotor amp
MBH	— (1,000) BTUH
MCA	— Min. circuit ampacity
MOCP	— Max. over-current protection
RPM	— Revolutions per minute
RTU	— Rooftop unit
SHC	— Sensible heat capacity
TC	— Total capacity

VII. Select factory options (FIOP)

Local code requires an economizer for any unit with TC greater than 65.0 MBH.

VIII. Calculate the total static pressure.

External static pressure	0.67 in. wg
Sum of FIOP / Accessory static	+0.13 in. wg
Total Static Pressure	0.80 in. wg

IX. Look up the indoor fan RPM & BHP.

Table 47 shows, at 2100 CFM & ESP= 0.8, RPM = 1358 & BHP = 1.52

X. Convert BHP (Step VIII) into fan motor heat.

Fan motor heat = 2.546* BHP/Motor Eff.⁴
 Fan motor heat = 4.9 MBH

XI. Calculate RTU heating capacity.

Building heating load	85.0 MBH
Fan motor heat	-4.9 MBH
Required heating capacity	80.1 MBH

XII. Select a gas heater.

Table 3 shows the heating capacities of the 48TCEA07 = 93.0 MBH. Select the 48TCEA07

XIII. Determine electrical requirements.

The MCA and MOCP tables show 48TC*A07 (without convenience outlet) as:
 MCA = 30.5 amps & MOCP = 45.0 amps
 Min. disconnect size: FLA = 30 & LRA = 157.

NOTES:

1. Selection software by Carrier saves time by performing many of the steps above. Contact your Carrier sales representative for assistance.
2. Unit ratings are gross capacities and do not include the effect of evaporator fan motor heat. See Step X. for determining amount of evaporator fan motor heat to subtract from total and sensible capacities to obtain net cooling and net sensible capacities.
3. Selecting a unit with a SHC slightly lower than the SHC_{Load} is often better than oversizing. Slightly lower SHC's will help control indoor humidity, and prevent temperature swings.
4. Indoor fan motor efficiency is available in Table 83. Use the decimal form in the equation, eg. 80% = .8.

Table 13 – COOLING CAPACITIES

1-STAGE COOLING

3 TONS

48TC*A04 (RTPF)				AMBIENT TEMPERATURE												
				85			95			105			115			
				EAT (db)			EAT (db)			EAT (db)			EAT (db)			
				75	80	85	75	80	85	75	80	85	75	80	85	
				900 Cfm		EAT (wb)	58	TC	28.1	28.1	31.7	26.3	26.3	29.8	24.5	24.5
SHC	24.4	28.1	31.7				22.9	26.3	29.8	21.3	24.5	27.7	19.6	22.6	25.5	
		62	TC	30.3	30.3	31.0	27.8	27.8	29.8	25.1	25.1	28.4	22.6	22.6	26.5	
			SHC	22.6	26.8	31.0	21.5	25.7	29.8	20.2	24.3	28.4	18.7	22.6	26.5	
		67	TC	35.5	35.5	35.5	33.1	33.1	33.1	30.5	30.5	30.5	27.5	27.5	27.5	
			SHC	19.5	23.7	27.9	18.5	22.7	26.9	17.4	21.6	25.8	16.2	20.4	24.6	
		72	TC	39.0	39.0	39.0	37.1	37.1	37.1	35.1	35.1	35.1	32.7	32.7	32.7	
			SHC	15.3	19.5	23.7	14.5	18.8	23.0	13.7	17.9	22.2	12.9	17.1	21.3	
		76	TC	-	41.4	41.4	-	39.6	39.6	-	37.6	37.6	-	35.4	35.4	
			SHC	-	16.0	21.0	-	15.4	20.2	-	14.6	19.3	-	13.8	18.3	
1050 Cfm		EAT (wb)	58	TC	30.2	30.2	34.2	28.4	28.4	32.2	26.5	26.5	30.0	24.5	24.5	27.7
			SHC	26.3	30.2	34.2	24.7	28.4	32.2	23.1	26.5	30.0	21.3	24.5	27.7	
		62	TC	31.9	31.9	34.2	29.4	29.4	32.8	26.7	26.7	31.2	24.5	24.5	28.8	
			SHC	24.6	29.4	34.2	23.4	28.1	32.8	22.0	26.6	31.2	20.3	24.5	28.8	
		67	TC	36.7	36.7	36.7	34.8	34.8	34.8	32.2	32.2	32.2	29.1	29.1	29.1	
			SHC	20.6	25.4	30.2	19.8	24.6	29.4	18.8	23.6	28.4	17.6	22.4	27.2	
		72	TC	40.1	40.1	40.1	38.2	38.2	38.2	36.1	36.1	36.1	33.7	33.7	33.7	
			SHC	15.7	20.5	25.3	15.0	19.8	24.6	14.2	19.0	23.8	13.4	18.2	23.0	
		76	TC	-	42.4	42.4	-	40.6	40.6	-	38.5	38.5	-	36.2	36.2	
			SHC	-	16.6	22.2	-	15.9	21.3	-	15.2	20.4	-	14.4	19.5	
1200 Cfm		EAT (wb)	58	TC	32.2	32.2	36.4	30.4	30.4	34.3	28.4	28.4	32.1	26.3	26.3	29.7
			SHC	28.0	32.2	36.4	26.4	30.4	34.3	24.7	28.4	32.1	22.8	26.3	29.7	
		62	TC	33.3	33.3	37.0	30.8	30.8	35.5	28.4	28.4	33.4	26.3	26.3	30.9	
			SHC	26.4	31.7	37.0	25.1	30.3	35.5	23.4	28.4	33.4	21.7	26.3	30.9	
		67	TC	37.7	37.7	37.7	35.6	35.6	35.6	33.4	33.4	33.4	30.4	30.4	30.4	
			SHC	21.7	27.0	32.4	20.9	26.3	31.6	20.0	25.4	30.8	18.8	24.2	29.6	
		72	TC	40.9	40.9	40.9	39.0	39.0	39.0	36.9	36.9	36.9	34.4	34.4	34.4	
			SHC	16.1	21.5	26.8	15.4	20.8	26.1	14.7	20.0	25.4	13.8	19.2	24.5	
		76	TC	-	43.1	43.1	-	41.3	41.3	-	39.1	39.1	-	36.8	36.8	
			SHC	-	17.1	23.1	-	16.4	22.3	-	15.7	21.4	-	14.9	20.5	
1350 Cfm		EAT (wb)	58	TC	-	-	-	32.1	32.1	36.3	30.0	30.0	34.0	27.9	27.9	31.5
			SHC	-	-	-	27.9	32.1	36.3	26.1	30.0	34.0	24.2	27.9	31.5	
		62	TC	28.4	28.4	30.5	32.2	32.2	37.8	30.1	30.1	35.3	27.9	27.9	32.8	
			SHC	17.6	24.1	30.5	26.6	32.2	37.8	24.8	30.1	35.3	23.0	27.9	32.8	
		67	TC	33.2	33.2	33.2	36.4	36.4	36.4	34.1	34.1	34.1	31.5	31.5	32.0	
			SHC	15.0	21.4	27.9	21.9	27.8	33.7	21.0	26.9	32.9	20.0	26.0	32.0	
		72	TC	37.5	37.5	37.5	39.7	39.7	39.7	37.5	37.5	37.5	35.0	35.0	35.0	
			SHC	11.8	18.3	24.8	15.8	21.7	27.5	15.0	20.9	26.8	14.2	20.1	26.0	
		76	TC	-	40.1	40.1	-	41.8	41.8	-	39.6	39.6	-	37.3	37.3	
			SHC	-	15.3	22.7	-	16.8	23.2	-	16.1	22.3	-	15.3	21.5	
1500 Cfm		EAT (wb)	58	TC	28.1	28.1	34.2	33.7	33.7	38.1	31.6	31.6	35.7	29.3	29.3	33.2
			SHC	21.9	28.1	34.2	29.3	33.7	38.1	27.4	31.6	35.7	25.5	29.3	33.2	
		62	TC	30.3	30.3	33.8	33.7	33.7	39.6	31.6	31.6	37.1	29.4	29.4	34.5	
			SHC	19.8	26.8	33.8	27.8	33.7	39.6	26.1	31.6	37.1	24.2	29.4	34.5	
		67	TC	35.5	35.5	35.5	36.9	36.9	36.9	34.6	34.6	34.9	32.0	32.0	34.0	
			SHC	16.7	23.7	30.7	22.8	29.2	35.7	21.9	28.4	34.9	21.0	27.5	34.0	
		72	TC	39.0	39.0	39.0	40.2	40.2	40.2	38.0	38.0	38.0	35.5	35.5	35.5	
			SHC	12.4	19.5	26.6	16.1	22.5	28.8	15.4	21.7	28.1	14.6	21.0	27.4	
		76	TC	-	41.4	41.4	-	42.2	42.2	-	40.0	40.0	-	-	-	
			SHC	-	16.0	24.3	-	17.2	24.0	-	16.5	23.2	-	-	-	

LEGEND:

- Do not operate
- Cfm - Cubic feet per minute (supply air)
- EAT(db) - Entering air temperature (dry bulb)
- EAT(wb) - Entering air temperature (wet bulb)
- SHC - Sensible heat capacity
- TC - Total capacity

48TC04 (3 TONS) – UNIT WITH HUMIDI-MIZER SYSTEM IN SUBCOOLING MODE										
Air Entering Evaporator – CFM										
Temp (F) Air Ent Condenser (Edb)		80 dry bulb			80 dry bulb			80 dry bulb		
		72 wet bulb			67 wet bulb			62 wet bulb		
		900	1200	1500	900	1200	1500	900	1200	1500
75	TC	40.6	43.2	45.3	37.0	39.4	41.3	33.4	35.6	37.4
	SHC	21.6	23.9	25.6	25.6	27.7	29.3	29.6	31.6	33.1
	kW	2.0	2.0	2.0	2.0	2.0	2.0	2.0	2.0	2.0
85	TC	37.0	39.6	41.7	33.6	36.0	37.9	30.2	32.3	34.1
	SHC	17.7	20.2	22.2	22.7	25.0	26.9	27.7	29.9	31.6
	kW	2.3	2.3	2.3	2.3	2.3	2.3	2.3	2.3	2.3
95	TC	33.5	36.0	38.1	30.2	32.5	34.4	26.9	29.1	30.8
	SHC	13.7	16.6	18.8	19.7	22.4	24.4	25.7	28.2	30.1
	kW	2.6	2.6	2.6	2.5	2.5	2.5	2.5	2.5	2.5
105	TC	29.9	32.4	34.5	26.8	29.1	31.0	23.6	25.8	27.5
	SHC	9.8	12.9	15.3	16.8	19.7	22.0	23.8	26.5	28.6
	kW	2.9	2.9	2.9	2.8	2.8	2.8	2.8	2.8	2.8
115	TC	26.3	28.8	30.9	23.3	25.7	27.5	20.4	22.5	24.2
	SHC	5.8	9.2	11.9	13.8	17.0	19.5	21.9	24.8	27.1
	kW	3.2	3.2	3.2	3.1	3.1	3.1	3.1	3.1	3.1

48TC04 (3 TONS) – UNIT WITH HUMIDI-MIZER SYSTEM IN HOT GAS REHEAT MODE										
Air Entering Evaporator – CFM										
Temp (F) Air Ent Condenser (Edb)		75 dry bulb			75 dry bulb			75 dry bulb		
		62.5 wet bulb (50% relative)			64 wet bulb (55% relative)			65.3 wet bulb (60% relative)		
		1050	1200	1350	1050	1200	1350	1050	1200	1350
80	TC	14.7	15.5	16.2	15.9	16.7	17.4	16.9	17.7	18.4
	SHC	6.7	7.6	8.5	4.8	5.7	6.6	3.2	4.1	5.0
	kW	2.0	2.0	2.0	2.0	2.0	2.0	2.0	2.0	2.0
75	TC	15.1	15.8	16.4	16.2	17.0	17.6	17.2	18.0	18.6
	SHC	7.5	8.4	9.2	5.8	6.7	7.5	4.4	5.2	6.0
	kW	1.9	1.9	1.9	2.0	2.0	2.0	2.0	2.0	2.0
70	TC	15.5	16.1	16.7	16.6	17.3	17.9	17.5	18.2	18.8
	SHC	8.4	9.3	10.0	6.9	7.7	8.5	5.5	6.4	7.1
	kW	1.9	1.9	1.9	1.9	1.9	1.9	1.9	1.9	1.9
60	TC	16.2	16.8	17.3	17.2	17.8	18.3	18.1	18.7	19.2
	SHC	10.2	10.9	11.6	8.9	9.7	10.4	7.8	8.6	9.3
	kW	1.8	1.8	1.8	1.8	1.8	1.8	1.9	1.9	1.9
50	TC	17.0	17.5	17.9	17.9	18.4	18.8	18.7	19.2	19.6
	SHC	11.9	12.6	13.2	11.0	11.6	12.2	10.1	10.8	11.4
	kW	1.7	1.7	1.7	1.8	1.8	1.8	1.8	1.8	1.8
40	TC	17.7	18.1	18.5	18.6	19.0	19.3	19.3	19.7	20.1
	SHC	13.7	14.3	14.8	13.0	13.6	14.1	12.4	13.0	13.5
	kW	1.7	1.7	1.7	1.7	1.7	1.7	1.7	1.7	1.7

LEGEND

- Edb – Entering Dry–Bulb
- Ewb – Entering Wet–Bulb
- kW – Compressor Motor Power Input
- ldb – Leaving Dry–Bulb
- lwb – Leaving Wet–Bulb
- SHC – Sensible Heat Capacity (1000 Btuh) Gross
- TC – Total Capacity (1000 Btuh) Gross

NOTES:

1. Direct interpolation is permissible. Do not extrapolate.
2. The following formulas may be used:

$$t_{ldb} = t_{edb} - \frac{\text{sensible capacity (Btuh)}}{1.10 \times \text{cfm}}$$

t_{lwb} = Wet–bulb temperature corresponding to enthalpy of air leaving evaporator coil (h_{lwb})

$$h_{lwb} = h_{ewb} - \frac{\text{total capacity (Btuh)}}{4.5 \times \text{cfm}}$$

Where: h_{ewb} = Enthalpy of air entering evaporator coil

Table 15 – COOLING CAPACITIES

1-STAGE COOLING

4 TONS

48TC*A05 (RTPF)			AMBIENT TEMPERATURE												
			85			95			105			115			
			EAT (db)			EAT (db)			EAT (db)			EAT (db)			
			75	80	85	75	80	85	75	80	85	75	80	85	
1200 Cfm	EAT (wb)	58	TC	-	-	-	-	-	-	36.1	36.1	40.7	34.3	34.3	38.6
		58	SHC	-	-	-	-	-	-	31.5	36.1	40.7	29.9	34.3	38.6
		62	TC	43.1	43.1	43.1	40.8	40.8	40.8	38.4	38.4	39.4	35.9	35.9	38.2
		62	SHC	31.2	36.4	41.7	30.1	35.3	40.6	28.9	34.1	39.4	27.8	33.0	38.2
		67	TC	47.4	47.4	47.4	45.2	45.2	45.2	42.9	42.9	42.9	40.3	40.3	40.3
		67	SHC	25.9	31.2	36.4	25.0	30.2	35.5	23.9	29.2	34.4	22.9	28.2	33.4
		72	TC	51.1	51.1	51.1	49.1	49.1	49.1	46.8	46.8	46.8	43.9	43.9	43.9
		72	SHC	20.1	25.5	30.9	19.4	24.7	30.1	18.4	23.7	29.0	17.4	22.7	28.0
		76	TC	-	53.3	53.3	-	51.5	51.5	-	49.2	49.2	-	45.9	45.9
		76	SHC	-	20.8	27.4	-	20.2	26.8	-	19.3	25.7	-	18.3	24.6
1400 cfm	EAT (wb)	58	TC	41.9	41.9	47.3	40.1	40.1	45.3	38.2	38.2	43.2	36.3	36.3	41.0
		58	SHC	36.6	41.9	47.3	35.0	40.1	45.3	33.3	38.2	43.2	31.7	36.3	41.0
		62	TC	44.6	44.6	45.4	42.3	42.3	44.2	39.8	39.8	42.9	37.3	37.3	41.6
		62	SHC	33.4	39.4	45.4	32.3	38.3	44.2	31.0	37.0	42.9	29.8	35.7	41.6
		67	TC	48.7	48.7	48.7	46.6	46.6	46.6	44.2	44.2	44.2	41.4	41.4	41.4
		67	SHC	27.3	33.2	39.2	26.4	32.3	38.3	25.3	31.3	37.3	24.2	30.2	36.2
		72	TC	52.2	52.2	52.2	50.3	50.3	50.3	47.8	47.8	47.8	44.8	44.8	44.8
		72	SHC	20.6	26.7	32.7	19.9	25.9	32.0	18.9	24.9	30.9	17.9	23.8	29.7
		76	TC	-	54.1	54.1	-	52.3	52.3	-	49.9	49.9	-	46.4	46.4
		76	SHC	-	21.5	29.0	-	20.8	28.0	-	19.9	26.9	-	18.8	25.7
1600 Cfm	EAT (wb)	58	TC	44.0	44.0	49.6	42.1	42.1	47.4	40.1	40.1	45.2	38.1	38.1	43.0
		58	SHC	38.3	44.0	49.6	36.7	42.1	47.4	34.9	40.1	45.2	33.2	38.1	43.0
		62	TC	45.7	45.7	48.6	43.5	43.5	47.5	41.0	41.0	46.0	38.5	38.5	44.4
		62	SHC	35.3	42.0	48.6	34.2	40.8	47.5	32.9	39.4	46.0	31.6	38.0	44.4
		67	TC	49.8	49.8	49.8	47.6	47.6	47.6	45.1	45.1	45.1	42.3	42.3	42.3
		67	SHC	28.4	35.0	41.6	27.6	34.2	40.9	26.5	33.2	39.9	25.4	32.1	38.7
		72	TC	53.0	53.0	53.0	51.1	51.1	51.1	48.6	48.6	48.6	45.4	45.4	45.4
		72	SHC	21.0	27.6	34.3	20.3	27.0	33.6	19.4	26.0	32.6	18.3	24.8	31.3
		76	TC	-	54.6	54.6	-	52.8	52.8	-	50.4	50.4	-	46.8	46.8
		76	SHC	-	22.0	29.9	-	21.3	29.0	-	20.3	27.9	-	19.2	26.6
1800 Cfm	EAT (wb)	58	TC	44.0	44.0	50.3	42.1	42.1	48.1	40.1	40.1	45.9	38.0	38.0	43.5
		58	SHC	37.6	44.0	50.3	36.0	42.1	48.1	34.3	40.1	45.9	32.6	38.0	43.5
		62	TC	45.7	45.7	49.5	43.5	43.5	48.3	41.0	41.0	46.8	38.4	38.4	45.2
		62	SHC	34.5	42.0	49.5	33.4	40.8	48.3	32.1	39.4	46.8	30.8	38.0	45.2
		67	TC	49.8	49.8	49.8	47.6	47.6	47.6	45.1	45.1	45.1	42.3	42.3	42.3
		67	SHC	27.6	35.0	42.5	26.8	34.2	41.7	25.7	33.2	40.7	24.6	32.1	39.5
		72	TC	53.0	53.0	53.0	51.1	51.1	51.1	48.6	48.6	48.6	45.4	45.4	45.4
		72	SHC	20.2	27.6	35.1	19.5	27.0	34.4	18.5	26.0	33.4	17.5	24.8	32.1
		76	TC	-	54.6	54.6	-	52.8	52.8	-	50.4	50.4	-	46.8	46.8
		76	SHC	-	22.0	30.9	-	21.3	30.0	-	20.3	28.9	-	19.2	27.5
2000 Cfm	EAT (wb)	58	TC	46.9	46.9	52.9	45.0	45.0	50.8	42.9	42.9	48.4	40.7	40.7	45.9
		58	SHC	40.9	46.9	52.9	39.3	45.0	50.8	37.4	42.9	48.4	35.5	40.7	45.9
		62	TC	47.5	47.5	54.0	45.3	45.3	52.5	43.0	43.0	50.3	40.7	40.7	47.7
		62	SHC	38.5	46.3	54.0	37.3	44.9	52.5	35.6	43.0	50.3	33.8	40.7	47.7
		67	TC	51.2	51.2	51.2	49.1	49.1	49.1	46.5	46.5	46.5	43.5	43.5	43.5
		67	SHC	30.5	38.3	46.0	29.8	37.6	45.5	28.7	36.6	44.5	27.5	35.4	43.2
		72	TC	54.0	54.0	54.0	52.1	52.1	52.1	49.7	49.7	49.7	46.2	46.2	46.2
		72	SHC	21.7	29.2	36.8	21.1	28.7	36.4	20.1	27.8	35.4	18.9	26.4	33.9
		76	TC	-	55.2	55.2	-	53.5	53.5	-	51.0	51.0	-	47.3	47.3
		76	SHC	-	22.7	31.4	-	22.0	30.6	-	21.1	29.6	-	19.9	28.1

LEGEND:

- - Do not operate
- Cfm - Cubic feet per minute (supply air)
- EAT(db) - Entering air temperature (dry bulb)
- EAT(wb) - Entering air temperature (wet bulb)
- SHC - Sensible heat capacity
- TC - Total capacity

48TC05 (4 TONS) – UNIT WITH HUMIDI-MIZER SYSTEM IN SUBCOOLING MODE										
Air Entering Evaporator – CFM										
Temp (F) Air Ent Condenser (Edb)		80 dry bulb			80 dry bulb			80 dry bulb		
		72 wet bulb			67 wet bulb			62 wet bulb		
		1200	1600	2000	1200	1600	2000	1200	1600	2000
75	TC	52.5	55.9	58.6	47.1	50.2	52.7	41.7	44.5	46.8
	SHC	22.6	25.5	27.8	27.1	29.9	32.0	31.6	34.2	36.2
	kW	2.5	2.5	2.5	2.5	2.5	2.5	2.5	2.5	2.5
85	TC	48.7	52.2	54.9	43.4	46.5	49.0	38.0	40.8	43.1
	SHC	18.0	21.3	23.9	23.6	26.8	29.2	29.3	32.2	34.4
	kW	2.9	2.9	2.9	2.9	2.9	2.9	2.9	2.9	2.9
95	TC	44.9	48.4	51.2	39.6	42.8	45.3	34.3	37.1	39.4
	SHC	13.4	17.2	20.0	20.2	23.7	26.4	27.0	30.2	32.7
	kW	3.4	3.4	3.4	3.3	3.3	3.3	3.3	3.3	3.3
105	TC	41.1	44.7	47.5	35.9	39.1	41.7	30.6	33.5	35.8
	SHC	8.8	13.0	16.1	16.7	20.6	23.6	24.6	28.2	31.0
	kW	3.8	3.8	3.8	3.7	3.7	3.7	3.7	3.7	3.7
115	TC	37.4	41.0	43.9	32.1	35.4	38.0	26.8	29.8	32.1
	SHC	4.3	8.8	12.2	13.3	17.5	20.7	22.3	26.2	29.2
	kW	4.2	4.2	4.2	4.2	4.2	4.2	4.1	4.1	4.1

48TC05 (4 TONS) – UNIT WITH HUMIDI-MIZER SYSTEM IN HOT GAS REHEAT MODE										
Air Entering Evaporator – CFM										
Temp (F) Air Ent Condenser (Edb)		75 dry bulb			75 dry bulb			75 dry bulb		
		62.5 wet bulb (50% relative)			64 wet bulb (55% relative)			65.3 wet bulb (60% relative)		
		1200	1600	2000	1200	1600	2000	1200	1600	2000
80	TC	11.6	13.8	15.5	13.5	15.8	17.6	15.2	17.5	19.3
	SHC	-1.0	1.2	3.0	-3.1	-0.8	0.9	-4.8	-2.6	-0.9
	kW	2.5	2.5	2.5	2.5	2.5	2.5	2.5	2.5	2.5
75	TC	12.5	14.6	16.2	14.3	16.4	18.1	15.9	18.1	19.8
	SHC	-0.7	1.4	3.0	-2.7	-0.6	1.1	-4.3	-2.2	-0.6
	kW	2.5	2.5	2.5	2.5	2.5	2.5	2.5	2.5	2.5
70	TC	13.4	15.3	16.8	15.1	17.1	18.7	16.6	18.7	20.3
	SHC	-0.5	1.5	3.0	-2.3	-0.3	1.2	-3.8	-1.9	-0.3
	kW	2.5	2.5	2.5	2.5	2.5	2.5	2.5	2.5	2.5
60	TC	15.1	16.8	18.1	16.7	18.4	19.8	18.1	19.9	21.2
	SHC	0.0	1.7	3.1	-1.5	0.2	1.5	-2.8	-1.1	0.2
	kW	2.6	2.6	2.6	2.6	2.6	2.6	2.6	2.6	2.6
50	TC	16.9	18.3	19.4	18.3	19.8	20.9	19.6	21.0	22.2
	SHC	0.6	2.0	3.1	-0.7	0.7	1.8	-1.8	-0.4	0.7
	kW	2.6	2.6	2.6	2.6	2.6	2.6	2.6	2.6	2.6
40	TC	18.7	19.8	20.7	19.9	21.1	22.0	21.0	22.2	23.2
	SHC	1.1	2.2	3.1	0.1	1.2	2.1	-0.8	0.4	1.3
	kW	2.6	2.6	2.6	2.7	2.7	2.7	2.7	2.7	2.7

LEGEND

- Edb – Entering Dry-Bulb
- Ewb – Entering Wet-Bulb
- kW – Compressor Motor Power Input
- ldb – Leaving Dry-Bulb
- lwb – Leaving Wet-Bulb
- SHC – Sensible Heat Capacity (1000 Btuh) Gross
- TC – Total Capacity (1000 Btuh) Gross

NOTES:

1. Direct interpolation is permissible. Do not extrapolate.
2. The following formulas may be used:

$$t_{ldb} = t_{edb} - \frac{\text{sensible capacity (Btuh)}}{1.10 \times \text{cfm}}$$

t_{lwb} = Wet-bulb temperature corresponding to enthalpy of air leaving evaporator coil (h_{lwb})

$$h_{lwb} = h_{ewb} - \frac{\text{total capacity (Btuh)}}{4.5 \times \text{cfm}}$$

Where: h_{ewb} = Enthalpy of air entering evaporator coil

Table 17 – COOLING CAPACITIES

1-STAGE COOLING

5 TONS

48TC*A06 (RTPF)				AMBIENT TEMPERATURE											
				85			95			105			115		
				EAT (db)			EAT (db)			EAT (db)			EAT (db)		
				75	80	85	75	80	85	75	80	85	75	80	85
				1500 Cfm	EAT (wb)	58	TC	52.9	52.9	60.0	49.9	49.9	56.6	46.6	46.6
SHC	45.8	52.9	60.0				43.2	49.9	56.6	40.4	46.6	52.9	37.3	43.1	48.9
62	TC	56.2	56.2			57.6	52.2	52.2	55.7	47.8	47.8	53.5	43.2	43.2	51.0
	SHC	41.8	49.7			57.6	39.9	47.8	55.7	37.8	45.6	53.5	35.5	43.2	51.0
67	TC	62.4	62.4			62.4	58.8	58.8	58.8	54.4	54.4	54.4	49.5	49.5	49.5
	SHC	34.8	42.8			50.7	33.2	41.2	49.1	31.4	39.3	47.3	29.4	37.3	45.3
72	TC	68.2	68.2			68.2	64.8	64.8	64.8	60.8	60.8	60.8	56.2	56.2	56.2
	SHC	27.2	35.2			43.2	25.9	33.9	41.9	24.4	32.4	40.4	22.6	30.6	38.6
76	TC	-	71.1			71.1	-	69.0	69.0	-	65.4	65.4	-	60.9	60.9
	SHC	-	28.4			36.6	-	27.6	35.9	-	26.3	34.6	-	24.8	33.0
1750 Cfm	EAT (wb)	58	TC	56.5	56.5	64.0	53.3	53.3	60.4	49.8	49.8	56.5	46.1	46.1	52.3
			SHC	48.9	56.5	64.0	46.1	53.3	60.4	43.1	49.8	56.5	39.9	46.1	52.3
		62	TC	58.5	58.5	63.4	54.4	54.4	61.3	49.9	49.9	58.9	46.1	46.1	54.4
			SHC	45.2	54.3	63.4	43.2	52.2	61.3	41.0	49.9	58.9	37.9	46.1	54.4
		67	TC	64.3	64.3	64.3	60.5	60.5	60.5	56.2	56.2	56.2	51.3	51.3	51.3
			SHC	36.9	46.1	55.2	35.3	44.5	53.7	33.6	42.8	51.9	31.6	40.8	49.9
		72	TC	69.5	69.5	69.5	66.5	66.5	66.5	62.4	62.4	62.4	57.7	57.7	57.7
			SHC	27.8	36.9	45.9	26.7	35.9	45.1	25.2	34.5	43.7	23.5	32.8	42.0
		76	TC	-	72.2	72.2	-	70.1	70.1	-	66.6	66.6	-	-	-
			SHC	-	29.3	38.9	-	28.6	38.2	-	27.4	36.8	-	-	-
2000 Cfm	EAT (wb)	58	TC	59.3	59.3	67.3	56.1	56.1	63.6	52.5	52.5	59.5	48.6	48.6	55.1
			SHC	51.4	59.3	67.3	48.6	56.1	63.6	45.4	52.5	59.5	42.1	48.6	55.1
		62	TC	60.1	60.1	68.5	56.2	56.2	66.3	52.5	52.5	62.0	48.7	48.7	57.4
			SHC	48.1	58.3	68.5	46.2	56.2	66.3	43.1	52.5	62.0	39.9	48.7	57.4
		67	TC	65.7	65.7	65.7	61.9	61.9	61.9	57.5	57.5	57.5	52.6	52.6	54.4
			SHC	38.8	49.1	59.5	37.3	47.7	58.1	35.6	46.0	56.4	33.6	44.0	54.4
		72	TC	70.1	70.1	70.1	67.6	67.6	67.6	63.6	63.6	63.6	58.9	58.9	58.9
			SHC	28.3	38.1	48.0	27.4	37.7	48.0	26.0	36.4	46.7	24.3	34.7	45.2
		76	TC	-	72.9	72.9	-	70.8	70.8	-	67.4	67.4	-	-	-
			SHC	-	30.1	40.7	-	29.3	39.9	-	28.2	38.7	-	-	-
2250 Cfm	EAT (wb)	58	TC	61.5	61.5	69.8	58.4	58.4	66.2	54.8	54.8	62.1	50.8	50.8	57.6
			SHC	53.2	61.5	69.8	50.5	58.4	66.2	47.4	54.8	62.1	43.9	50.8	57.6
		62	TC	61.6	61.6	72.6	58.4	58.4	68.9	54.8	54.8	64.6	50.8	50.8	59.9
			SHC	50.6	61.6	72.6	47.9	58.4	68.9	45.0	54.8	64.6	41.7	50.8	59.9
		67	TC	66.8	66.8	66.8	63.0	63.0	63.0	58.5	58.5	60.6	53.6	53.6	58.6
			SHC	40.5	52.0	63.4	39.1	50.7	62.3	37.4	49.0	60.6	35.5	47.0	58.6
		72	TC	70.8	70.8	70.8	68.5	68.5	68.5	64.5	64.5	64.5	59.8	59.8	59.8
			SHC	28.7	39.5	50.2	28.0	39.3	50.5	26.7	38.1	49.6	25.0	36.6	48.1
		76	TC	-	73.4	73.4	-	71.2	71.2	-	67.9	67.9	-	-	-
			SHC	-	30.7	42.1	-	30.0	41.4	-	28.9	40.4	-	-	-
2500 Cfm	EAT (wb)	58	TC	63.3	63.3	71.8	60.1	60.1	68.2	56.5	56.5	64.1	52.6	52.6	59.6
			SHC	54.8	63.3	71.8	52.1	60.1	68.2	49.0	56.5	64.1	45.5	52.6	59.6
		62	TC	63.4	63.4	74.7	60.2	60.2	71.0	56.6	56.6	66.7	52.6	52.6	62.1
			SHC	52.0	63.4	74.7	49.4	60.2	71.0	46.5	56.6	66.7	43.2	52.6	62.1
		67	TC	67.6	67.6	67.6	63.8	63.8	66.2	59.3	59.3	64.6	54.4	54.4	62.5
			SHC	42.1	54.6	67.1	40.9	53.5	66.2	39.2	51.9	64.6	37.2	49.8	62.5
		72	TC	71.3	71.3	71.3	69.0	69.0	69.0	65.1	65.1	65.1	60.4	60.4	60.4
			SHC	29.1	40.7	52.2	28.5	40.7	52.9	27.3	39.7	52.2	25.7	38.3	50.9
		76	TC	-	73.8	73.8	-	71.4	71.4	-	68.3	68.3	-	-	-
			SHC	-	31.2	43.3	-	30.5	42.6	-	29.6	41.9	-	-	-

LEGEND:

- Do not operate
- Cfm - Cubic feet per minute (supply air)
- EAT(db) - Entering air temperature (dry bulb)
- EAT(wb) - Entering air temperature (wet bulb)
- SHC - Sensible heat capacity
- TC - Total capacity

48TC06 (5 TONS) – UNIT WITH HUMIDI-MIZER SYSTEM IN SUBCOOLING MODE										
Air Entering Evaporator – CFM										
Temp (F) Air Ent Condenser (Edb)		80 dry bulb			80 dry bulb			80 dry bulb		
		72 wet bulb			67 wet bulb			62 wet bulb		
		1750	2000	2250	1750	2000	2250	1750	2000	2250
75	TC	73.1	78.7	84.5	63.2	66.9	70.8	53.2	55.1	57.1
	SHC	35.3	37.2	38.8	42.0	43.7	45.3	48.7	50.3	51.8
	kW	3.3	3.3	3.3	3.3	3.3	3.3	3.3	3.3	3.3
85	TC	67.6	71.2	75.0	59.1	61.2	63.3	50.6	51.1	51.5
	SHC	27.9	30.0	31.9	36.3	38.3	40.1	44.8	46.6	48.2
	kW	3.8	3.8	3.8	3.8	3.8	3.8	3.8	3.8	3.8
95	TC	62.1	63.8	65.5	55.1	55.4	55.8	48.0	47.0	46.0
	SHC	20.5	22.9	24.9	30.7	32.9	34.8	40.9	42.9	44.7
	kW	4.3	4.3	4.3	4.3	4.3	4.3	4.3	4.3	4.3
105	TC	56.6	56.3	56.0	51.0	49.6	48.3	45.4	43.0	40.5
	SHC	13.1	15.7	18.0	25.0	27.5	29.6	36.9	39.2	41.2
	kW	4.8	4.8	4.8	4.8	4.8	4.8	4.7	4.7	4.7
115	TC	51.1	48.8	46.5	46.9	43.9	40.7	42.8	39.0	35.0
	SHC	5.8	8.6	11.0	19.4	22.0	24.4	33.0	35.5	37.7
	kW	5.3	5.3	5.3	5.3	5.3	5.3	5.2	5.2	5.2

48TC06 (5 TONS) – UNIT WITH HUMIDI-MIZER SYSTEM IN HOT GAS REHEAT MODE										
Air Entering Evaporator – CFM										
Temp (F) Air Ent Condenser (Edb)		75 dry bulb			75 dry bulb			75 dry bulb		
		62.5 wet bulb (50% relative)			64 wet bulb (55% relative)			65.3 wet bulb (60% relative)		
		1750	2000	2250	1750	2000	2250	1750	2000	2250
80	TC	23.0	24.4	25.6	24.7	26.2	27.4	26.3	27.7	29.0
	SHC	5.3	6.1	6.8	3.2	4.0	4.7	1.4	2.2	2.9
	kW	2.9	2.9	2.9	2.9	2.9	2.9	2.9	2.9	2.9
75	TC	23.3	24.6	25.7	25.0	26.3	27.5	26.4	27.8	29.0
	SHC	5.1	5.8	6.5	3.1	3.9	4.5	1.4	2.2	2.8
	kW	2.9	2.9	2.9	2.9	2.9	2.9	2.9	2.9	2.9
70	TC	23.5	24.8	25.9	25.2	26.4	27.5	26.6	27.9	29.0
	SHC	4.8	5.5	6.2	3.0	3.7	4.3	1.4	2.1	2.8
	kW	3.0	3.0	3.0	3.0	3.0	3.0	3.0	3.0	3.0
60	TC	24.1	25.2	26.1	25.6	26.7	27.7	26.9	28.0	29.0
	SHC	4.3	5.0	5.5	2.8	3.4	3.9	1.4	2.0	2.6
	kW	3.0	3.0	3.0	3.0	3.0	3.0	3.0	3.0	3.0
50	TC	24.7	25.6	26.4	26.1	27.0	27.8	27.2	28.2	29.0
	SHC	3.8	4.4	4.8	2.5	3.1	3.5	1.4	2.0	2.4
	kW	3.1	3.1	3.1	3.1	3.1	3.1	3.1	3.1	3.1
40	TC	25.3	26.0	26.7	26.5	27.3	27.9	27.6	28.3	29.0
	SHC	3.3	3.8	4.2	2.3	2.8	3.1	1.4	1.9	2.3
	kW	3.1	3.1	3.1	3.2	3.2	3.2	3.2	3.2	3.2

LEGEND

- Edb – Entering Dry–Bulb
- Ewb – Entering Wet–Bulb
- kW – Compressor Motor Power Input
- ldb – Leaving Dry–Bulb
- lwb – Leaving Wet–Bulb
- SHC – Sensible Heat Capacity (1000 Btuh) Gross
- TC – Total Capacity (1000 Btuh) Gross

NOTES:

1. Direct interpolation is permissible. Do not extrapolate.
2. The following formulas may be used:

$$t_{ldb} = t_{edb} - \frac{\text{sensible capacity (Btuh)}}{1.10 \times \text{cfm}}$$

t_{lwb} = Wet–bulb temperature corresponding to enthalpy of air leaving evaporator coil (h_{lwb})

$$h_{lwb} = h_{ewb} - \frac{\text{total capacity (Btuh)}}{4.5 \times \text{cfm}}$$

Where: h_{ewb} = Enthalpy of air entering evaporator coil

Table 19 – COOLING CAPACITIES

1-STAGE COOLING

6 TONS

48TC*A07 (RTPF)			AMBIENT TEMPERATURE													
			85			95			105			115				
			EAT (db)			EAT (db)			EAT (db)			EAT (db)				
			75	80	85	75	80	85	75	80	85	75	80	85		
1800 Cfm	EAT (wb)	58	TC	64.9	64.9	73.3	62.1	62.1	70.0	58.9	58.9	66.4	55.6	55.6	62.7	
			SHC	56.6	64.9	73.3	54.1	62.1	70.0	51.4	58.9	66.4	48.5	55.6	62.7	
		62	TC	68.7	68.7	70.3	64.9	64.9	68.5	60.8	60.8	66.4	56.4	56.4	64.0	
			SHC	51.7	61.0	70.3	49.9	59.2	68.5	47.9	57.2	66.4	45.7	54.9	64.0	
		67	TC	75.6	75.6	75.6	71.7	71.7	71.7	67.4	67.4	67.4	62.5	62.5	62.5	
			SHC	42.8	52.2	61.5	41.2	50.5	59.8	39.3	48.6	58.0	37.2	46.5	55.8	
	72	TC	82.6	82.6	82.6	78.5	78.5	78.5	73.7	73.7	73.7	67.8	67.8	67.8		
		SHC	33.5	42.8	52.2	31.9	41.3	50.6	30.0	39.3	48.6	27.8	36.9	45.9		
	76	TC	-	87.5	87.5	-	83.3	83.3	-	77.7	77.7	-	70.9	70.9		
		SHC	-	35.0	44.9	-	33.5	43.4	-	31.6	41.5	-	29.3	39.1		
	2100 Cfm	EAT (wb)	58	TC	68.9	68.9	77.7	65.9	65.9	74.3	62.5	62.5	70.5	58.7	58.7	66.2
				SHC	60.1	68.9	77.7	57.4	65.9	74.3	54.5	62.5	70.5	51.2	58.7	66.2
62			TC	70.9	70.9	76.9	67.1	67.1	75.0	63.0	63.0	72.5	58.7	58.7	68.7	
			SHC	55.6	66.3	76.9	53.8	64.4	75.0	51.6	62.1	72.5	48.7	58.7	68.7	
67			TC	77.8	77.8	77.8	73.7	73.7	73.7	69.2	69.2	69.2	64.0	64.0	64.0	
			SHC	45.4	56.1	66.8	43.7	54.4	65.2	41.8	52.5	63.2	39.6	50.2	60.7	
72		TC	84.5	84.5	84.5	80.3	80.3	80.3	75.1	75.1	75.1	68.8	68.8	68.8		
		SHC	34.5	45.2	55.9	32.9	43.5	54.2	30.9	41.4	52.0	28.5	38.7	48.9		
76		TC	-	89.2	89.2	-	84.7	84.7	-	78.8	78.8	-	71.6	71.6		
		SHC	-	36.3	47.8	-	34.7	46.0	-	32.6	43.7	-	30.1	40.9		
2400 Cfm		EAT (wb)	58	TC	72.0	72.0	81.2	68.7	68.7	77.5	65.2	65.2	73.5	61.1	61.1	68.9
				SHC	62.8	72.0	81.2	60.0	68.7	77.5	56.9	65.2	73.5	53.3	61.1	68.9
	62		TC	72.8	72.8	82.8	68.9	68.9	80.7	65.2	65.2	76.4	61.2	61.2	71.6	
			SHC	59.1	71.0	82.8	57.2	68.9	80.7	54.1	65.2	76.4	50.7	61.2	71.6	
	67		TC	79.4	79.4	79.4	75.2	75.2	75.2	70.5	70.5	70.5	65.1	65.1	65.3	
			SHC	47.7	59.8	71.8	46.0	58.1	70.2	44.0	56.0	68.1	41.6	53.5	65.3	
	72	TC	86.0	86.0	86.0	81.6	81.6	81.6	76.1	76.1	76.1	69.6	69.6	69.6		
		SHC	35.3	47.2	59.2	33.7	45.6	57.5	31.7	43.3	55.0	29.1	40.3	51.4		
	76	TC	-	90.3	90.3	-	85.7	85.7	-	79.6	79.6	-	72.1	72.1		
		SHC	-	37.3	49.8	-	35.6	48.0	-	33.5	45.6	-	30.8	42.5		
	2700 Cfm	EAT (wb)	58	TC	60.3	60.3	74.1	71.1	71.1	80.2	67.4	67.4	76.0	63.0	63.0	71.1
				SHC	46.4	60.3	74.1	62.0	71.1	80.2	58.8	67.4	76.0	55.0	63.0	71.1
62			TC	65.4	65.4	69.3	71.2	71.2	83.3	67.5	67.5	79.0	63.1	63.1	73.8	
			SHC	41.0	55.1	69.3	59.0	71.2	83.3	55.9	67.5	79.0	52.3	63.1	73.8	
67			TC	72.7	72.7	72.7	76.3	76.3	76.3	71.5	71.5	72.6	65.8	65.8	69.4	
			SHC	33.8	48.0	62.2	48.2	61.6	74.9	46.1	59.3	72.6	43.5	56.5	69.4	
72		TC	79.7	79.7	79.7	82.5	82.5	82.5	76.9	76.9	76.9	70.1	70.1	70.1		
		SHC	25.8	40.2	54.6	34.5	47.5	60.5	32.3	45.0	57.7	29.7	41.7	53.8		
76		TC	-	85.1	85.1	-	86.4	86.4	-	80.2	80.2	-	72.5	72.5		
		SHC	-	33.5	48.4	-	36.5	49.9	-	34.3	47.3	-	31.5	44.0		
3000 Cfm		EAT (wb)	58	TC	64.9	64.9	78.8	73.1	73.1	82.5	69.2	69.2	78.0	64.5	64.5	72.7
				SHC	51.1	64.9	78.8	63.8	73.1	82.5	60.3	69.2	78.0	56.2	64.5	72.7
	62		TC	68.7	68.7	76.5	73.2	73.2	85.7	69.2	69.2	81.0	64.5	64.5	75.5	
			SHC	45.5	61.0	76.5	60.7	73.2	85.7	57.4	69.2	81.0	53.5	64.5	75.5	
	67		TC	75.6	75.6	75.6	77.2	77.2	79.4	72.2	72.2	76.8	66.3	66.3	73.0	
			SHC	36.6	52.2	67.7	50.2	64.8	79.4	48.0	62.4	76.8	45.1	59.1	73.0	
	72	TC	82.6	82.6	82.6	83.3	83.3	83.3	77.5	77.5	77.5	70.5	70.5	70.5		
		SHC	27.2	42.8	58.5	35.1	49.2	63.3	32.9	46.6	60.3	30.2	43.0	55.9		
	76	TC	-	87.5	87.5	-	86.9	86.9	-	80.6	80.6	-	72.8	72.8		
		SHC	-	35.0	51.5	-	37.3	51.6	-	35.0	48.9	-	32.1	45.3		

LEGEND:

- Do not operate in this region
- Cfm - Cubic feet per minute (supply air)
- EAT(db) - Entering air temperature (dry bulb)
- EAT(wb) - Entering air temperature (wet bulb)
- SHC - Sensible heat capacity
- TC - Total capacity

48TC07 (6 TONS) – UNIT WITH HUMIDI-MIZER SYSTEM IN SUBCOOLING MODE										
Air Entering Evaporator – CFM										
Temp (F) Air Ent Condenser (Edb)		80 dry bulb			80 dry bulb			80 dry bulb		
		72 wet bulb			67 wet bulb			62 wet bulb		
		2100	2400	2700	2100	2400	2700	2100	2400	2700
75	TC	86.7	89.9	92.8	79.3	82.3	84.9	71.9	74.6	77.0
	SHC	40.1	41.8	43.3	46.9	48.5	49.9	53.7	55.2	56.5
	kW	4.3	4.3	4.3	4.2	4.2	4.2	4.2	4.2	4.2
85	TC	79.5	82.6	85.4	72.5	75.3	77.9	65.4	68.0	70.3
	SHC	32.1	34.0	35.7	40.7	42.5	44.1	49.4	51.0	52.5
	kW	5.0	5.0	5.0	5.0	5.0	5.0	4.9	4.9	4.9
95	TC	72.4	75.3	78.1	65.6	68.3	70.8	58.8	61.3	63.6
	SHC	24.1	26.3	28.1	34.6	36.6	38.3	45.1	46.9	48.5
	kW	5.8	5.8	5.8	5.7	5.7	5.7	5.6	5.6	5.6
105	TC	65.2	68.1	70.7	58.7	61.4	63.8	52.3	54.7	56.8
	SHC	16.2	18.5	20.5	28.5	30.6	32.6	40.7	42.8	44.6
	kW	6.5	6.5	6.5	6.4	6.4	6.4	6.3	6.3	6.3
115	TC	58.0	60.8	63.3	51.9	54.4	56.7	45.7	48.0	50.1
	SHC	8.2	10.7	13.0	22.3	24.7	26.8	36.4	38.6	40.6
	kW	7.2	7.2	7.2	7.1	7.1	7.1	7.0	7.0	7.0

48TC07 (6 TONS) – UNIT WITH HUMIDI-MIZER SYSTEM IN HOT GAS REHEAT MODE										
Air Entering Evaporator – CFM										
Temp (F) Air Ent Condenser (Edb)		75 dry bulb			75 dry bulb			75 dry bulb		
		62.5 wet bulb (50% relative)			64 wet bulb (55% relative)			65.3 wet bulb (60% relative)		
		2100	2400	2700	2100	2400	2700	1750	2000	2700
80	TC	16.7	19.8	22.5	18.8	21.9	24.7	16.2	19.4	26.7
	SHC	0.6	0.6	0.6	-0.4	-0.4	-0.4	-1.3	-1.3	-1.3
	kW	4.0	4.0	4.0	4.0	4.0	4.0	4.0	4.0	4.0
75	TC	17.7	20.6	23.1	19.6	22.6	25.3	17.3	20.3	27.1
	SHC	0.6	0.6	0.6	-0.3	-0.3	-0.3	-1.2	-1.2	-1.2
	kW	4.0	4.0	4.0	4.0	4.0	4.0	4.0	4.0	4.0
70	TC	18.6	21.3	23.7	20.5	23.3	25.8	18.3	21.1	27.6
	SHC	0.7	0.7	0.7	-0.2	-0.2	-0.2	-1.0	-1.0	-1.0
	kW	4.0	4.0	4.0	4.1	4.1	4.1	4.1	4.1	4.1
60	TC	20.5	22.9	25.0	22.2	24.7	26.8	20.4	22.8	28.5
	SHC	0.7	0.7	0.7	-0.0	-0.0	-0.0	-0.7	-0.7	-0.7
	kW	4.1	4.1	4.1	4.1	4.1	4.1	4.1	4.1	4.1
50	TC	22.4	24.4	26.2	24.0	26.0	27.9	22.4	24.5	29.3
	SHC	0.8	0.8	0.8	0.1	0.1	0.1	-0.4	-0.4	-0.4
	kW	4.1	4.1	4.1	4.1	4.1	4.1	4.2	4.2	4.2
40	TC	24.3	25.9	27.4	25.7	27.4	28.9	24.5	26.3	30.2
	SHC	0.8	0.8	0.8	0.3	0.3	0.3	-0.1	-0.1	-0.1
	kW	4.1	4.1	4.1	4.2	4.2	4.2	4.2	4.2	4.2

LEGEND

- Edb – Entering Dry-Bulb
- Ewb – Entering Wet-Bulb
- kW – Compressor Motor Power Input
- ldb – Leaving Dry-Bulb
- lwb – Leaving Wet-Bulb
- SHC – Sensible Heat Capacity (1000 Btuh) Gross
- TC – Total Capacity (1000 Btuh) Gross

NOTES:

1. Direct interpolation is permissible. Do not extrapolate.
2. The following formulas may be used:

$$t_{ldb} = t_{edb} - \frac{\text{sensible capacity (Btuh)}}{1.10 \times \text{cfm}}$$

t_{lwb} = Wet-bulb temperature corresponding to enthalpy of air leaving evaporator coil (h_{lwb})

$$h_{lwb} = h_{ewb} - \frac{\text{total capacity (Btuh)}}{4.5 \times \text{cfm}}$$

Where: h_{ewb} = Enthalpy of air entering evaporator coil

Table 21 – COOLING CAPACITIES

1-STAGE COOLING

7.5 TONS

48TC*A08 (RTPF)			AMBIENT TEMPERATURE												
			85			95			105			115			
			EAT (db)			EAT (db)			EAT (db)			EA (db)			
			75	80	85	75	80	85	75	80	85	75	80	85	
2250 Cfm	EAT (wb)	58	TC	81.2	81.2	91.8	77.5	77.5	87.7	73.6	73.6	83.3	69.5	69.5	78.7
			SHC	70.5	81.2	91.8	67.3	77.5	87.7	63.9	73.6	83.3	60.4	69.5	78.7
		62	TC	86.9	86.9	86.9	82.3	82.3	84.0	77.2	77.2	81.5	71.9	71.9	78.8
			SHC	63.6	74.9	86.2	61.4	72.7	84.0	58.9	70.2	81.5	56.3	67.6	78.8
		67	TC	95.2	95.2	95.2	90.7	90.7	90.7	85.7	85.7	85.7	79.9	79.9	79.9
			SHC	52.8	64.2	75.6	50.9	62.2	73.6	48.8	60.1	71.5	46.3	57.6	68.9
		72	TC	103.5	103.5	103.5	98.9	98.9	98.9	93.8	93.8	93.8	87.3	87.3	87.3
			SHC	41.5	53.1	64.6	39.7	51.2	62.7	37.7	49.2	60.6	35.3	46.6	57.8
		76	TC	-	109.6	109.6	-	104.8	104.8	-	99.1	99.1	-	91.6	91.6
			SHC	-	43.7	56.0	-	42.0	54.3	-	40.0	52.4	-	37.4	49.8
2625 Cfm	EAT (wb)	58	TC	85.9	85.9	97.2	82.2	82.2	93.1	78.1	78.1	88.4	73.9	73.9	83.6
			SHC	74.6	85.9	97.2	71.4	82.2	93.1	67.9	78.1	88.4	64.1	73.9	83.6
		62	TC	89.6	89.6	94.1	85.1	85.1	91.7	80.1	80.1	89.1	74.6	74.6	86.0
			SHC	68.1	81.1	94.1	65.9	78.8	91.7	63.4	76.3	89.1	60.6	73.3	86.0
		67	TC	97.9	97.9	97.9	93.2	93.2	93.2	88.1	88.1	88.1	82.0	82.0	82.0
			SHC	55.7	68.7	81.7	53.7	66.7	79.8	51.6	64.6	77.6	49.0	62.0	74.9
		72	TC	106.0	106.0	106.0	101.3	101.3	101.3	95.9	95.9	95.9	89.0	89.0	89.0
			SHC	42.7	55.8	68.9	40.9	53.9	67.0	38.8	51.8	64.7	36.2	48.9	61.7
		76	TC	-	111.8	111.8	-	106.9	106.9	-	100.7	100.7	-	92.7	92.7
			SHC	-	45.3	59.8	-	43.6	58.0	-	41.4	55.6	-	38.7	52.6
3000 Cfm	EAT (wb)	58	TC	89.6	89.6	101.4	85.9	85.9	97.2	81.7	81.7	92.5	77.0	77.0	87.1
			SHC	77.9	89.6	101.4	74.6	85.9	97.2	71.0	81.7	92.5	66.9	77.0	87.1
		62	TC	91.8	91.8	101.1	87.2	87.2	98.6	82.3	82.3	95.5	77.1	77.1	90.6
			SHC	72.2	86.7	101.1	69.9	84.3	98.6	67.2	81.3	95.5	63.5	77.1	90.6
		67	TC	99.9	99.9	99.9	95.2	95.2	95.2	89.9	89.9	89.9	83.6	83.6	83.6
			SHC	58.3	72.9	87.5	56.4	71.0	85.5	54.2	68.8	83.4	51.6	66.1	80.5
		72	TC	107.9	107.9	107.9	103.0	103.0	103.0	97.3	97.3	97.3	90.1	90.1	90.1
			SHC	43.7	58.3	72.8	41.9	56.4	70.9	39.7	54.1	68.4	37.0	51.0	65.0
		76	TC	-	113.8	113.8	-	108.4	108.4	-	102.0	102.0	-	93.4	93.4
			SHC	-	46.7	62.5	-	44.8	60.4	-	42.6	57.9	-	39.6	54.7
3375 Cfm	EAT (wb)	58	TC	92.7	92.7	104.9	88.8	88.8	100.5	84.6	84.6	95.7	79.6	79.6	90.0
			SHC	80.5	92.7	104.9	77.1	88.8	100.5	73.4	84.6	95.7	69.1	79.6	90.0
		62	TC	93.7	93.7	107.3	89.1	89.1	104.7	84.6	84.6	99.5	79.6	79.6	93.6
			SHC	75.8	91.6	107.3	73.5	89.1	104.7	69.8	84.6	99.5	65.6	79.6	93.6
		67	TC	101.5	101.5	101.5	96.7	96.7	96.7	91.3	91.3	91.3	84.8	84.8	85.7
			SHC	60.8	76.9	93.0	58.8	74.9	91.0	56.7	72.8	88.9	53.9	69.8	85.7
		72	TC	109.4	109.4	109.4	104.3	104.3	104.3	98.4	98.4	98.4	90.9	90.9	90.9
			SHC	44.6	60.5	76.4	42.8	58.6	74.4	40.5	56.2	71.8	37.7	52.8	68.0
		76	TC	-	115.1	115.1	-	109.5	109.5	-	102.8	102.8	-	94.0	94.0
			SHC	-	47.8	64.9	-	45.9	62.7	-	43.5	60.1	-	40.4	56.5
3750 Cfm	EAT (wb)	58	TC	95.3	95.3	107.8	91.3	91.3	103.3	86.9	86.9	98.3	81.7	81.7	92.4
			SHC	82.7	95.3	107.8	79.3	91.3	103.3	75.5	86.9	98.3	70.9	81.7	92.4
		62	TC	95.5	95.5	112.2	91.3	91.3	107.4	87.0	87.0	102.2	81.7	81.7	96.0
			SHC	78.7	95.5	112.2	75.3	91.3	107.4	71.7	87.0	102.2	67.4	81.7	96.0
		67	TC	102.8	102.8	102.8	97.9	97.9	97.9	92.3	92.3	94.0	85.7	85.7	90.5
			SHC	63.1	80.6	98.2	61.2	78.7	96.3	59.0	76.5	94.0	56.0	73.2	90.5
		72	TC	110.6	110.6	110.6	105.4	105.4	105.4	99.2	99.2	99.2	91.5	91.5	91.5
			SHC	45.5	62.7	79.9	43.5	60.7	77.8	41.3	58.1	75.0	38.3	54.5	70.7
		76	TC	-	116.1	116.1	-	110.3	110.3	-	103.5	103.5	-	94.5	94.5
			SHC	-	48.9	67.0	-	46.8	64.8	-	44.4	62.0	-	41.1	58.1

LEGEND:

- Do not operate in this region
- Cfm - Cubic feet per minute (supply air)
- EAT(db) - Entering air temperature (dry bulb)
- EAT(wb) - Entering air temperature (wet bulb)
- SHC - Sensible heat capacity
- TC - Total capacity

Table 22 – COOLING CAPACITIES

2-STAGE COOLING

7.5 TONS

48TC*D08 (RTPF & Novation)			AMBIENT TEMPERATURE												
			85			95			105			115			
			EAT (db)			EAT (db)			EAT (db)			EA (db)			
			75	80	85	75	80	85	75	80	85	75	80	85	
2250 Cfm	EAT (wb)	58	TC	77.4	77.4	87.8	73.8	73.8	83.8	70.1	70.1	79.5	66.0	66.0	74.9
			SHC	66.9	77.4	87.8	63.9	73.8	83.8	60.6	70.1	79.5	57.1	66.0	74.9
		62	TC	82.2	82.2	83.9	77.5	77.5	81.7	72.6	72.6	79.2	67.3	67.3	76.4
			SHC	60.8	72.4	83.9	58.6	70.1	81.7	56.3	67.7	79.2	53.6	65.0	76.4
		67	TC	90.1	90.1	90.1	86.0	86.0	86.0	81.4	81.4	81.4	75.9	75.9	75.9
			SHC	50.2	61.8	73.3	48.5	60.1	71.6	46.5	58.1	69.7	44.2	55.8	67.4
		72	TC	98.0	98.0	98.0	94.0	94.0	94.0	89.5	89.5	89.5	84.3	84.3	84.3
			SHC	39.1	50.7	62.4	37.5	49.2	60.9	35.8	47.5	59.2	33.8	45.5	57.2
		76	TC	-	104.3	104.3	-	100.4	100.4	-	95.9	95.9	-	90.7	90.7
			SHC	-	41.7	54.0	-	40.3	52.7	-	38.7	51.0	-	36.8	49.0
2625 Cfm	EAT (wb)	58	TC	82.1	82.1	93.2	78.4	78.4	89.0	74.4	74.4	84.4	70.0	70.0	79.5
			SHC	71.0	82.1	93.2	67.8	78.4	89.0	64.3	74.4	84.4	60.6	70.0	79.5
		62	TC	84.9	84.9	91.8	80.4	80.4	89.5	75.4	75.4	86.7	70.2	70.2	82.9
			SHC	65.4	78.6	91.8	63.2	76.3	89.5	60.6	73.7	86.7	57.6	70.2	82.9
		67	TC	92.5	92.5	92.5	88.3	88.3	88.3	83.6	83.6	83.6	78.3	78.3	78.3
			SHC	53.0	66.3	79.5	51.3	64.6	78.0	49.4	62.8	76.1	47.2	60.6	73.9
		72	TC	100.4	100.4	100.4	96.4	96.4	96.4	91.7	91.7	91.7	86.4	86.4	86.4
			SHC	40.2	53.5	66.7	38.7	52.0	65.3	36.9	50.3	63.7	35.0	48.4	61.8
		76	TC	-	106.5	106.5	-	102.6	102.6	-	98.0	98.0	-	92.7	92.7
			SHC	-	43.3	57.6	-	41.8	55.9	-	40.2	54.1	-	38.4	52.2
3000 Cfm	EAT (wb)	58	TC	85.7	85.7	97.3	82.2	82.2	93.3	78.0	78.0	88.6	73.5	73.5	83.4
			SHC	74.1	85.7	97.3	71.1	82.2	93.3	67.5	78.0	88.6	63.6	73.5	83.4
		62	TC	86.9	86.9	98.7	82.8	82.8	96.4	78.2	78.2	92.3	73.6	73.6	86.9
			SHC	69.3	84.0	98.7	67.2	81.8	96.4	64.1	78.2	92.3	60.3	73.6	86.9
		67	TC	94.3	94.3	94.3	90.1	90.1	90.1	85.2	85.2	85.2	79.8	79.8	80.1
			SHC	55.6	70.5	85.4	54.0	68.9	83.9	52.1	67.1	82.2	49.9	65.0	80.1
		72	TC	102.2	102.2	102.2	98.1	98.1	98.1	93.3	93.3	93.3	87.9	87.9	87.9
			SHC	41.2	56.0	70.7	39.7	54.6	69.5	38.0	53.0	68.0	36.0	51.1	66.2
		76	TC	-	108.1	108.1	-	104.2	104.2	-	99.5	99.5	-	94.2	94.2
			SHC	-	44.5	60.2	-	43.2	58.7	-	41.6	57.0	-	39.8	55.2
3375 Cfm	EAT (wb)	58	TC	88.5	88.5	100.4	85.0	85.0	96.4	81.0	81.0	92	76.5	76.5	86.8
			SHC	76.5	88.5	100.4	73.5	85.0	96.4	70.1	81.0	92	66.1	76.5	86.8
		62	TC	88.9	88.9	103.9	85.1	85.1	100.4	81.1	81.1	95.7	76.5	76.5	90.3
			SHC	72.3	88.1	103.9	69.7	85.1	100.4	66.5	81.1	95.7	62.7	76.5	90.3
		67	TC	95.8	95.8	95.8	91.5	91.5	91.5	86.6	86.6	87.9	81.1	81.1	85.8
			SHC	58.0	74.4	90.9	56.4	73.0	89.6	54.6	71.3	87.9	52.4	69.1	85.8
		72	TC	103.6	103.6	103.6	99.4	99.4	99.4	94.6	94.6	94.6	89.1	89.1	89.1
			SHC	42.0	58.3	74.5	40.6	57.0	73.4	38.9	55.5	72.0	37.0	53.7	70.3
		76	TC	-	109.2	109.2	-	105.4	105.4	-	100.7	100.7	-	95.3	95.3
			SHC	-	45.6	62.6	-	44.4	61.3	-	42.8	59.7	-	41.0	58.0
3750 Cfm	EAT (wb)	58	TC	90.8	90.8	103.0	87.3	87.3	99.1	83.3	83.3	94.5	78.8	78.8	89.4
			SHC	78.5	90.8	103.0	75.5	87.3	99.1	72.0	83.3	94.5	68.2	78.8	89.4
		62	TC	90.9	90.9	107.2	87.4	87.4	103.1	83.3	83.3	98.4	78.9	78.9	93.1
			SHC	74.5	90.9	107.2	71.6	87.4	103.1	68.3	83.3	98.4	64.7	78.9	93.1
		67	TC	97.0	97.0	97.0	92.6	92.6	95.1	87.6	87.6	93.4	82.1	82.1	91.2
			SHC	60.3	78.2	96.2	58.8	76.9	95.1	56.9	75.2	93.4	54.8	73.0	91.2
		72	TC	104.7	104.7	104.7	100.5	100.5	100.5	95.6	95.6	95.6	90.1	90.1	90.1
			SHC	42.9	60.5	78.1	41.4	59.3	77.1	39.8	57.8	75.9	37.9	56.1	74.3
		76	TC	-	110.2	110.2	-	106.2	106.2	-	101.6	101.6	-	96.1	96.1
			SHC	-	46.7	64.8	-	45.4	63.6	-	44.0	62.3	-	42.2	60.6

* See Minimum–Maximum Airflow Ratings in Table 6. Do not operate outside these limits.

LEGEND:

- Do not operate in this region
- Cfm - Cubic feet per minute (supply air)
- EAT(db) - Entering air temperature (dry bulb)
- EAT(wb) - Entering air temperature (wet bulb)
- SHC - Sensible heat capacity
- TC - Total capacity

48TC08 COOLING CAPACITIES, UNIT WITH HUMIDI-MIZER SYSTEM IN SUBCOOLING MODE										
TEMP (F) AIR ENT CONDENSER (Edb)		AIR ENTERING EVAPORATOR – CFM								
		2250/0.05			3000/0.07			3750/0.09		
		Air Entering Evaporator – Ewb (F)								
		72	67	62	72	67	62	72	67	62
75	TC	103.05	93.02	83.60	109.77	99.52	90.08	114.01	103.69	95.19
	SHC	43.66	55.34	67.09	50.99	66.29	81.31	57.49	76.27	92.20
	kW	4.90	4.83	4.77	4.82	4.88	4.96	4.99	4.91	4.85
85	TC	95.39	85.83	76.88	101.59	91.89	82.95	105.53	95.76	87.77
	SHC	36.42	48.47	60.60	43.24	58.99	74.40	49.44	68.68	84.90
	kW	5.49	5.42	5.36	5.40	5.47	5.54	5.58	5.50	5.44
95	TC	87.48	78.44	69.97	93.21	84.05	75.61	96.84	87.63	80.14
	SHC	28.98	41.46	53.97	35.32	51.53	67.34	41.21	60.92	77.41
	kW	6.16	6.09	6.03	6.08	6.14	6.21	6.24	6.17	6.11
105	TC	79.35	70.83	62.84	84.57	75.96	68.04	87.88	79.23	72.26
	SHC	21.34	34.26	47.18	27.17	43.86	60.08	32.73	52.95	69.70
	kW	6.93	6.86	6.81	6.85	6.91	6.97	7.00	6.93	6.88
115	TC	70.87	62.89	55.42	75.58	67.54	60.15	78.56	70.51	64.06
	SHC	13.40	26.79	40.14	18.70	35.89	52.54	23.94	44.68	61.67
	kW	7.79	7.74	7.69	7.73	7.78	7.83	7.86	7.80	7.76

48TC08 COOLING CAPACITIES, UNIT WITH HUMIDI-MIZER SYSTEM IN HOT GAS REHEAT MODE										
TEMP (F) AIR ENT CONDENSER (Edb)		AIR ENTERING EVAPORATOR – Ewb (F)								
		75 Dry Bulb 62.5 Wet Bulb (50% Relative)			75 Dry Bulb 64 Wet Bulb (56% Relative)			75 Dry Bulb 65.3 Wet Bulb (60% Relative)		
		Air Entering Evaporator – Cfm								
		2250	3000	3750	2250	3000	3750	2250	3000	3750
80	TC	27.60	32.75	30.19	40.09	39.43	37.73	45.06	45.25	44.25
	SHC	-3.12	5.20	6.71	3.75	5.24	6.75	3.77	5.26	6.78
	kW	4.56	4.51	4.46	4.63	4.60	4.56	4.70	4.67	4.64
75	TC	35.40	33.78	31.20	41.14	40.51	38.80	46.15	46.37	45.38
	SHC	4.67	6.17	7.69	4.71	6.21	7.73	4.74	6.24	7.76
	kW	4.41	4.36	4.39	4.41	4.36	4.36	4.41	4.39	4.36
70	TC	36.36	34.71	32.18	42.10	41.47	39.77	47.08	47.31	46.32
	SHC	5.63	7.14	8.66	5.67	7.18	8.71	5.70	7.21	8.74
	kW	4.43	4.49	4.41	4.44	4.40	4.39	4.49	4.47	4.44
60	TC	38.25	36.64	34.15	43.97	43.37	41.72	48.98	49.22	48.26
	SHC	7.56	9.09	10.62	7.60	9.13	10.66	7.62	9.15	10.69
	kW	4.56	4.55	4.43	4.57	4.53	4.46	4.56	4.55	4.50
50	TC	40.15	38.60	36.14	45.95	45.37	43.73	50.57	50.97	49.56
	SHC	9.48	11.03	12.58	9.52	11.07	12.62	9.54	11.10	12.64
	kW	4.63	4.52	4.38	4.45	4.41	4.33	5.25	4.91	5.60
40	TC	42.18	40.62	38.11	47.80	47.25	45.43	52.65	52.75	51.83
	SHC	11.41	12.98	14.54	11.45	13.02	14.58	11.47	13.04	14.60
	kW	4.32	4.37	4.37	4.65	4.60	4.89	4.96	5.20	5.12

LEGEND

- Edb – Entering Dry–Bulb
- Ewb – Entering Wet–Bulb
- kW – Compressor Motor Power Input
- ldb – Leaving Dry–Bulb
- lwb – Leaving Wet–Bulb
- SHC – Sensible Heat Capacity (1000 Btuh) Gross
- TC – Total Capacity (1000 Btuh) Gross

NOTES:

1. Direct interpolation is permissible. Do not extrapolate.
2. The following formulas may be used:

$$t_{ldb} = t_{edb} - \frac{\text{sensible capacity (Btuh)}}{1.10 \times \text{cfm}}$$

t_{lwb} = Wet–bulb temperature corresponding to enthalpy of air leaving evaporator coil (h_{lwb})

$$h_{lwb} = h_{ewb} - \frac{\text{total capacity (Btuh)}}{4.5 \times \text{cfm}}$$

Where: h_{ewb} = Enthalpy of air entering evaporator coil

Table 24 – COOLING CAPACITIES

1-STAGE COOLING

8.5 TONS

48TC*A09 (RTPF)			AMBIENT TEMPERATURE												
			85			95			105			115			
			EAT (db)			EAT (db)			EAT (db)			EAT (db)			
			75	80	85	75	80	85	75	80	85	75	80	85	
2550 Cfm	EAT (wb)	58	TC	88.1	88.1	99.9	84.1	84.1	95.3	79.6	79.6	90.3	74.9	74.9	84.9
			SHC	76.4	88.1	99.9	72.8	84.1	95.3	69.0	79.6	90.3	64.9	74.9	84.9
		62	TC	93.9	93.9	95.2	88.6	88.6	92.6	82.8	82.8	89.7	76.6	76.6	86.5
			SHC	69.4	82.3	95.2	66.8	79.7	92.6	64.1	76.9	89.7	61.0	73.8	86.5
		67	TC	103.8	103.8	103.8	98.7	98.7	98.7	93.0	93.0	93.0	86.7	86.7	86.7
			SHC	57.8	70.7	83.6	55.6	68.5	81.4	53.1	66.1	79.0	50.5	63.4	76.4
		72	TC	113.1	113.1	113.1	108.0	108.0	108.0	102.4	102.4	102.4	96.1	96.1	96.1
			SHC	45.2	58.3	71.3	43.2	56.3	69.3	41.1	54.1	67.1	38.7	51.7	64.7
		76	TC	-	119.9	119.9	-	114.7	114.7	-	109.0	109.0	-	102.7	102.7
			SHC	-	47.9	61.9	-	46.0	60.1	-	44.1	58.1	-	41.9	55.8
2975 Cfm	EAT (wb)	58	TC	93.6	93.6	106.1	89.3	89.3	101.2	84.6	84.6	96.0	79.6	79.6	90.3
			SHC	81.1	93.6	106.1	77.4	89.3	101.2	73.3	84.6	96.0	69.0	79.6	90.3
		62	TC	97.5	97.5	104.3	92.0	92.0	101.4	86.1	86.1	98.3	79.8	79.8	94.1
			SHC	74.7	89.5	104.3	72.0	86.7	101.4	69.1	83.7	98.3	65.6	79.8	94.1
		67	TC	106.7	106.7	106.7	101.5	101.5	101.5	95.7	95.7	95.7	89.2	89.2	89.2
			SHC	61.0	75.8	90.6	58.8	73.6	88.5	56.4	71.3	86.1	53.8	68.7	83.6
		72	TC	115.8	115.8	115.8	110.6	110.6	110.6	104.9	104.9	104.9	98.4	98.4	98.4
			SHC	46.5	61.3	76.2	44.5	59.4	74.2	42.3	57.2	72.1	40.0	54.8	69.7
		76	TC	-	122.4	122.4	-	117.0	117.0	-	111.1	111.1	-	104.5	104.5
			SHC	-	49.8	66.1	-	47.8	63.9	-	45.7	61.6	-	43.4	59.0
3400 Cfm	EAT (wb)	58	TC	98.1	98.1	111.3	93.7	93.7	106.2	88.9	88.9	100.8	83.7	83.7	94.9
			SHC	85.0	98.1	111.3	81.2	93.7	106.2	77.0	88.9	100.8	72.5	83.7	94.9
		62	TC	100.0	100.0	112.3	94.9	94.9	108.6	89.1	89.1	104.9	83.8	83.8	98.7
			SHC	79.3	95.8	112.3	76.3	92.5	108.6	73.2	89.1	104.9	68.8	83.8	98.7
		67	TC	109.0	109.0	109.0	103.6	103.6	103.6	97.6	97.6	97.6	91.0	91.0	91.0
			SHC	63.9	80.5	97.2	61.8	78.5	95.2	59.4	76.1	92.9	56.8	73.5	90.3
		72	TC	117.9	117.9	117.9	112.5	112.5	112.5	106.6	106.6	106.6	100.0	100.0	100.0
			SHC	47.6	64.1	80.6	45.6	62.1	78.7	43.4	60.0	76.6	41.1	57.6	74.2
		76	TC	-	124.2	124.2	-	118.6	118.6	-	112.5	112.5	-	105.7	105.7
			SHC	-	51.2	69.0	-	49.2	66.7	-	47.0	64.4	-	44.7	61.9
3825 Cfm	EAT (wb)	58	TC	101.6	101.6	115.1	97.2	97.2	110.1	92.3	92.3	104.6	87.0	87.0	98.6
			SHC	88.0	101.6	115.1	84.2	97.2	110.1	80.0	92.3	104.6	75.4	87.0	98.6
		62	TC	101.9	101.9	120.0	97.3	97.3	114.6	92.4	92.4	108.9	87.1	87.1	102.6
			SHC	83.7	101.8	120.0	79.9	97.3	114.6	75.9	92.4	108.9	71.6	87.1	102.6
		67	TC	110.7	110.7	110.7	105.3	105.3	105.3	99.2	99.2	99.3	92.5	92.5	96.7
			SHC	66.7	85.0	103.4	64.6	83.0	101.5	62.2	80.8	99.3	59.6	78.2	96.7
		72	TC	119.4	119.4	119.4	114.0	114.0	114.0	108.0	108.0	108.0	101.3	101.3	101.3
			SHC	48.5	66.6	84.6	46.6	64.7	82.7	44.4	62.6	80.7	42.1	60.2	78.4
		76	TC	-	125.5	125.5	-	119.8	119.8	-	113.6	113.6	-	106.7	106.7
			SHC	-	52.4	71.5	-	50.4	69.3	-	48.2	67.0	-	45.9	64.4
4250 Cfm	EAT (wb)	58	TC	104.4	104.4	118.3	99.9	99.9	113.2	95.0	95.0	107.6	89.5	89.5	101.5
			SHC	90.4	104.4	118.3	86.6	99.9	113.2	82.3	95.0	107.6	77.6	89.5	101.5
		62	TC	104.4	104.4	123.0	99.9	99.9	117.8	95.0	95.0	112.0	89.6	89.6	105.6
			SHC	85.8	104.4	123.0	82.1	99.9	117.8	78.1	95.0	112.0	73.6	89.6	105.6
		67	TC	112.1	112.1	112.1	106.6	106.6	107.5	100.4	100.4	105.3	93.6	93.6	102.7
			SHC	69.2	89.2	109.2	67.2	87.3	107.5	64.9	85.1	105.3	62.3	82.5	102.7
		72	TC	120.7	120.7	120.7	115.1	115.1	115.1	109.0	109.0	109.0	102.2	102.2	102.2
			SHC	49.4	68.9	88.4	47.4	67.0	86.5	45.3	64.9	84.6	42.9	62.6	82.3
		76	TC	-	126.6	126.6	-	120.8	120.8	-	114.5	114.5	-	107.4	107.4
			SHC	-	53.5	73.9	-	51.5	71.7	-	49.3	69.4	-	46.9	66.8

LEGEND:

- Do not operate in this region
- Cfm - Cubic feet per minute (supply air)
- EAT(db) - Entering air temperature (dry bulb)
- EAT(wb) - Entering air temperature (wet bulb)
- SHC - Sensible heat capacity
- TC - Total capacity

Table 25 – COOLING CAPACITIES

2-STAGE COOLING

8.5 TONS

48TC*D09 (RTPF)			AMBIENT TEMPERATURE												
			85			95			105			115			
			EA (dB)			EA (dB)			EA (dB)			EA (dB)			
			75	80	85	75	80	85	75	80	85	75	80	85	
2550 Cfm	EAT (wb)	58	TC	89.7	89.7	101.6	85.2	85.2	96.5	79.6	79.6	90.1	73.8	73.8	83.6
			SHC	77.8	89.7	101.6	73.9	85.2	96.5	69.0	79.6	90.1	64.0	73.8	83.6
		62	TC	94.3	94.3	97.9	88.7	88.7	95.2	81.3	81.3	91.5	74.3	74.3	86.5
			SHC	71.0	84.4	97.9	68.2	81.7	95.2	64.7	78.1	91.5	60.6	73.6	86.5
		67	TC	105.0	105.0	105.0	99.3	99.3	99.3	92.2	92.2	92.2	84.1	84.1	84.1
			SHC	59.0	72.6	86.1	56.6	70.1	83.7	53.6	67.1	80.7	50.3	63.8	77.3
		72	TC	115.9	115.9	115.9	110.4	110.4	110.4	104.2	104.2	104.2	96.0	96.0	96.0
			SHC	46.4	60.0	73.6	44.3	57.9	71.5	41.9	55.5	69.1	38.8	52.4	65.9
		76	TC	-	123.7	123.7	-	118.3	118.3	-	112.4	112.4	-	105.7	105.7
			SHC	-	49.3	63.3	-	47.3	61.4	-	45.3	59.3	-	42.9	56.7
2975 Cfm	EAT (wb)	58	TC	95.3	95.3	107.9	90.7	90.7	102.7	84.8	84.8	96.1	78.7	78.7	89.1
			SHC	82.6	95.3	107.9	78.6	90.7	102.7	73.5	84.8	96.1	68.2	78.7	89.1
		62	TC	97.9	97.9	107.8	92.1	92.1	104.7	85.4	85.4	99.4	78.8	78.8	92.8
			SHC	76.7	92.2	107.8	73.9	89.3	104.7	69.6	84.5	99.4	64.8	78.8	92.8
		67	TC	108.5	108.5	108.5	102.6	102.6	102.6	95.4	95.4	95.4	86.9	86.9	86.9
			SHC	62.8	78.4	94.1	60.4	76.0	91.7	57.4	73.1	88.8	54.0	69.7	85.3
		72	TC	119.1	119.1	119.1	113.5	113.5	113.5	107.2	107.2	107.2	99.2	99.2	99.2
			SHC	47.9	63.5	79.2	45.8	61.5	77.1	43.5	59.2	74.9	40.6	56.3	72.0
		76	TC	-	126.4	126.4	-	120.8	120.8	-	114.8	114.8	-	108.2	108.2
			SHC	-	51.1	67.4	-	49.2	65.3	-	47.0	63.0	-	44.8	60.7
3400 Cfm	EAT (wb)	58	TC	100.0	100.0	113.3	95.2	95.2	107.9	89.3	89.3	101.1	82.9	82.9	93.9
			SHC	86.7	100.0	113.3	82.6	95.2	107.9	77.4	89.3	101.1	71.8	82.9	93.9
		62	TC	101.1	101.1	115.8	95.7	95.7	111.7	89.4	89.4	105.3	83.0	83.0	97.7
			SHC	81.5	98.7	115.8	78.2	94.9	111.7	73.5	89.4	105.3	68.2	83.0	97.7
		67	TC	111.1	111.1	111.1	105.1	105.1	105.1	97.8	97.8	97.8	89.1	89.1	93.0
			SHC	66.2	83.9	101.6	63.9	81.6	99.3	61.0	78.7	96.5	57.5	75.3	93.0
		72	TC	121.3	121.3	121.3	115.6	115.6	115.6	109.4	109.4	109.4	101.5	101.5	101.5
			SHC	49.2	66.7	84.3	47.1	64.7	82.3	44.9	62.5	80.2	42.1	59.9	77.7
		76	TC	-	128.3	128.3	-	122.6	122.6	-	116.3	116.3	-	109.7	109.7
			SHC	-	52.7	70.7	-	50.7	68.6	-	48.6	66.4	-	46.4	64.2
3825 Cfm	EAT (wb)	58	TC	104.0	104.0	117.8	99.1	99.1	112.3	93.2	93.2	105.5	86.5	86.5	97.9
			SHC	90.2	104.0	117.8	86.0	99.1	112.3	80.8	93.2	105.5	75.0	86.5	97.9
		62	TC	104.2	104.2	122.7	99.3	99.3	116.9	93.3	93.3	109.8	86.6	86.6	101.9
			SHC	85.7	104.2	122.7	81.7	99.3	116.9	76.7	93.3	109.8	71.2	86.6	101.9
		67	TC	113.1	113.1	113.1	107.1	107.1	107.1	99.9	99.9	103.8	91.0	91.0	100.3
			SHC	69.4	89.1	108.8	67.1	86.8	106.5	64.3	84.1	103.8	60.9	80.6	100.3
		72	TC	123.0	123.0	123.0	117.2	117.2	117.2	110.9	110.9	110.9	103.3	103.3	103.3
			SHC	50.3	69.7	89.0	48.3	67.7	87.1	46.1	65.6	85.2	43.5	63.3	83.0
		76	TC	-	129.7	129.7	-	124.0	124.0	-	117.5	117.5	-	110.8	110.8
			SHC	-	54.0	73.7	-	52.1	71.7	-	50.0	69.5	-	47.8	67.4
4250 Cfm	EAT (wb)	58	TC	107.4	107.4	121.7	102.5	102.5	116.1	96.5	96.5	109.3	89.5	89.5	101.4
			SHC	93.1	107.4	121.7	88.9	102.5	116.1	83.7	96.5	109.3	77.6	89.5	101.4
		62	TC	107.5	107.5	126.6	102.6	102.6	120.8	96.6	96.6	113.7	89.6	89.6	105.5
			SHC	88.4	107.5	126.6	84.4	102.6	120.8	79.5	96.6	113.7	73.7	89.6	105.5
		67	TC	114.7	114.7	115.6	108.7	108.7	113.5	101.7	101.7	110.8	92.6	92.6	107.2
			SHC	72.5	94.0	115.6	70.2	91.8	113.5	67.5	89.2	110.8	64.0	85.6	107.2
		72	TC	124.3	124.3	124.3	118.5	118.5	118.5	112.1	112.1	112.1	104.7	104.7	104.7
			SHC	51.3	72.4	93.4	49.3	70.5	91.7	47.2	68.5	89.9	44.7	66.4	88.1
		76	TC	-	130.7	130.7	-	125.0	125.0	-	118.5	118.5	-	111.6	111.6
			SHC	-	55.3	76.5	-	53.5	74.6	-	51.3	72.4	-	49.2	70.3

* See Minimum–Maximum Airflow Ratings in Table 6. Do not operate outside these limits.

LEGEND:

- Do not operate in this region
- Cfm - Cubic feet per minute (supply air)
- EAT(db) - Entering air temperature (dry bulb)
- EAT(wb) - Entering air temperature (wet bulb)
- SHC - Sensible heat capacity
- TC - Total capacity

48TC09 COOLING CAPACITIES, UNIT WITH HUMIDI-MIZER SYSTEM IN SUBCOOLING MODE										
TEMP (F) AIR ENT CONDENSER (Edb)		AIR ENTERING EVAPORATOR – CFM								
		2550/0.04			3400/0.05			4250/0.07		
		Air Entering Evaporator – Ewb (F)								
		72	67	62	72	67	62	72	67	62
75	TC	119.20	107.44	96.41	126.95	114.98	103.92	131.87	119.81	109.54
	SHC	50.63	63.94	77.40	59.17	76.72	94.21	66.80	88.44	108.22
	kW	5.67	5.57	5.47	5.54	5.63	5.74	5.79	5.68	5.59
85	TC	110.40	99.22	88.76	117.63	106.26	95.77	122.21	110.77	101.07
	SHC	42.39	56.16	70.07	50.42	68.45	86.38	57.71	79.86	99.95
	kW	6.33	6.23	6.14	6.20	6.30	6.40	6.45	6.34	6.25
95	TC	101.37	90.79	80.86	108.07	97.31	87.39	112.29	101.47	92.38
	SHC	33.97	48.22	62.56	41.46	60.01	78.39	48.40	71.09	91.47
	kW	7.08	6.99	6.90	6.96	7.05	7.16	7.20	7.09	7.01
105	TC	92.04	82.06	72.71	98.19	88.05	78.72	102.07	91.86	83.40
	SHC	25.31	40.06	54.88	32.24	51.33	70.17	38.85	62.06	82.67
	kW	7.94	7.85	7.77	7.83	7.91	8.01	8.06	7.95	7.87
115	TC	82.37	73.01	64.24	87.95	78.45	69.73	91.46	81.90	74.09
	SHC	16.38	31.65	46.95	22.71	42.37	61.69	28.94	52.74	73.52
	kW	8.92	8.84	8.77	8.82	8.89	8.98	9.02	8.93	8.86

48TC09 COOLING CAPACITIES, UNIT WITH HUMIDI-MIZER SYSTEM IN HOT GAS REHEAT MODE										
TEMP (F) AIR ENT CONDENSER (Edb)		AIR ENTERING EVAPORATOR – Ewb (F)								
		75 Dry Bulb 62.5 Wet Bulb (50% Relative)			75 Dry Bulb 64 Wet Bulb (56% Relative)			75 Dry Bulb 65.3 Wet Bulb (60% Relative)		
		Air Entering Evaporator – Cfm								
		2550	3400	4250	2550	3400	4250	2550	3400	4250
80	TC	37.61	33.13	26.77	44.74	41.60	36.46	50.96	48.99	44.93
	SHC	-0.52	-0.63	-0.73	-0.46	-0.57	-0.67	-0.42	-0.53	-0.62
	kW	5.88	5.68	5.44	6.13	5.97	5.76	6.35	6.24	6.06
75	TC	38.71	34.24	27.86	45.84	42.73	37.59	52.05	50.11	46.06
	SHC	0.45	0.34	0.25	0.50	0.40	0.31	0.54	0.44	0.36
	kW	5.68	5.47	5.22	5.94	5.78	5.56	6.18	6.07	5.88
70	TC	39.70	35.25	28.83	46.80	43.70	38.59	52.97	51.04	47.02
	SHC	1.41	1.32	1.23	1.47	1.37	1.29	1.50	1.41	1.34
	kW	5.65	5.42	5.24	5.97	5.79	5.53	6.26	6.13	5.91
60	TC	41.77	37.33	30.76	48.86	45.80	40.71	55.00	53.10	49.12
	SHC	3.34	3.26	3.18	3.40	3.32	3.25	3.43	3.36	3.29
	kW	5.42	5.15	5.17	5.80	5.59	5.30	6.16	6.01	5.75
50	TC	43.83	39.27	32.61	50.92	47.89	42.70	57.04	55.16	51.22
	SHC	5.27	5.21	5.14	5.32	5.27	5.21	5.36	5.31	5.25
	kW	5.18	5.15	5.17	5.62	5.39	5.05	6.04	5.87	5.59
40	TC	45.75	41.13	34.50	53.08	50.00	44.64	59.24	57.40	53.44
	SHC	7.20	7.15	6.95	7.26	7.21	7.16	7.29	7.25	7.21
	kW	4.79	4.98	4.80	5.25	5.01	5.23	5.68	5.51	5.21

LEGEND

- Edb – Entering Dry–Bulb
- Ewb – Entering Wet–Bulb
- kW – Compressor Motor Power Input
- ldb – Leaving Dry–Bulb
- lwb – Leaving Wet–Bulb
- SHC – Sensible Heat Capacity (1000 Btuh) Gross
- TC – Total Capacity (1000 Btuh) Gross

NOTES:

1. Direct interpolation is permissible. Do not extrapolate.
2. The following formulas may be used:

$$t_{ldb} = t_{edb} - \frac{\text{sensible capacity (Btuh)}}{1.10 \times \text{cfm}}$$

t_{lwb} = Wet–bulb temperature corresponding to enthalpy of air leaving evaporator coil (h_{lwb})

$$h_{lwb} = h_{ewb} - \frac{\text{total capacity (Btuh)}}{4.5 \times \text{cfm}}$$

Where: h_{ewb} = Enthalpy of air entering evaporator coil

Table 27 – COOLING CAPACITIES

1-STAGE COOLING

10 TONS

48TC*A12 (RTPF)			AMBIENT TEMPERATURE												
			85			95			105			115			
			EAT (db)			EAT (db)			EAT (db)			EAT (db)			
Cfm	EAT (wb)	Type	75	80	85	75	80	85	75	80	85	75	80	85	
			3000	EAT (wb)	58	TC	106.3	106.3	120.5	101.7	101.7	115.2	96.6	96.6	109.4
	SHC	92.2	106.3		120.5	88.2	101.7	115.2	83.8	96.6	109.4	78.9	91.0	103.1	
	62	TC	112.5		112.5	115.2	106.5	106.5	112.3	99.9	99.9	109.0	92.7	92.7	105.2
	SHC	83.8	99.5		115.2	81.0	96.6	112.3	77.8	93.4	109.0	74.2	89.7	105.2	
	67	TC	123.5		123.5	123.5	117.8	117.8	117.8	111.3	111.3	111.3	104.0	104.0	104.0
	SHC	69.2	85.0		100.7	66.8	82.5	98.3	64.1	79.8	95.5	61.0	76.8	92.5	
	72	TC	134.3		134.3	134.3	128.5	128.5	128.5	122.0	122.0	122.0	114.7	114.7	114.7
	SHC	53.8	69.6		85.5	51.6	67.4	83.2	49.1	64.9	80.7	46.3	62.1	77.9	
	76	TC	-		142.4	142.4	-	136.3	136.3	-	129.5	129.5	-	121.8	121.8
	SHC	-	56.8		73.3	-	54.7	71.2	-	52.3	68.8	-	49.7	66.2	
3500	EAT (wb)	58	TC	112.9	112.9	127.8	108.0	108.0	122.3	102.7	102.7	116.3	96.8	96.8	109.7
		SHC	97.9	112.9	127.8	93.6	108.0	122.3	89.0	102.7	116.3	83.9	96.8	109.7	
		62	TC	116.3	116.3	126.2	110.5	110.5	123.3	103.8	103.8	119.5	97.1	97.1	114.3
		SHC	90.2	108.2	126.2	87.4	105.3	123.3	84.0	101.8	119.5	79.8	97.1	114.3	
		67	TC	126.9	126.9	126.9	120.9	120.9	120.9	114.3	114.3	114.3	106.8	106.8	106.8
		SHC	73.2	91.3	109.4	70.8	88.9	107.1	68.1	86.2	104.4	65.0	83.2	101.3	
		72	TC	137.5	137.5	137.5	131.4	131.4	131.4	124.7	124.7	124.7	117.2	117.2	117.2
		SHC	55.3	73.4	91.5	53.1	71.1	89.2	50.6	68.7	86.7	47.8	65.9	83.9	
		76	TC	-	145.1	145.1	-	138.8	138.8	-	131.7	131.7	-	123.6	123.6
		SHC	-	59.0	78.2	-	56.7	75.8	-	54.3	73.1	-	51.5	70.0	
4000	EAT (wb)	58	TC	117.8	117.8	133.5	113.0	113.0	128.0	107.5	107.5	121.8	101.5	101.5	115.0
		SHC	102.2	117.8	133.5	98.0	113.0	128.0	93.3	107.5	121.8	88.0	101.5	115.0	
		62	TC	119.1	119.1	136.0	113.5	113.5	132.5	107.7	107.7	126.7	101.6	101.6	119.6
		SHC	95.8	115.9	136.0	92.8	112.6	132.5	88.6	107.7	126.7	83.6	101.6	119.6	
		67	TC	129.4	129.4	129.4	123.3	123.3	123.3	116.5	116.5	116.5	108.9	108.9	109.8
		SHC	76.9	97.3	117.7	74.5	95.0	115.4	71.8	92.3	112.8	68.8	89.3	109.8	
		72	TC	139.7	139.7	139.7	133.5	133.5	133.5	126.6	126.6	126.6	118.8	118.8	118.8
		SHC	56.7	76.8	97.0	54.4	74.6	94.7	51.9	72.1	92.3	49.1	69.3	89.5	
		76	TC	-	147.0	147.0	-	140.5	140.5	-	133.2	133.2	-	124.9	124.9
		SHC	-	60.6	81.7	-	58.4	79.3	-	55.8	76.5	-	53.0	73.5	
4500	EAT (wb)	58	TC	121.7	121.7	137.9	116.8	116.8	132.3	111.2	111.2	126.0	105.0	105.0	118.9
		SHC	105.6	121.7	137.9	101.3	116.8	132.3	96.4	111.2	126.0	91.0	105.0	118.9	
		62	TC	121.8	121.8	143.4	116.9	116.9	137.6	111.3	111.3	131.0	105.1	105.1	123.7
		SHC	100.2	121.8	143.4	96.1	116.9	137.6	91.6	111.3	131.0	86.5	105.1	123.7	
		67	TC	131.3	131.3	131.3	125.1	125.1	125.1	118.2	118.2	120.8	110.5	110.5	117.7
		SHC	80.3	102.9	125.5	78.0	100.7	123.3	75.3	98.0	120.8	72.3	95.0	117.7	
		72	TC	141.5	141.5	141.5	135.1	135.1	135.1	128.0	128.0	128.0	120.1	120.1	120.1
		SHC	57.9	80.0	102.1	55.6	77.7	99.9	53.1	75.2	97.4	50.3	72.4	94.6	
		76	TC	-	148.3	148.3	-	141.8	141.8	-	134.3	134.3	-	125.8	125.8
		SHC	-	62.1	84.9	-	59.8	82.5	-	57.3	79.7	-	54.4	76.6	
5000	EAT (wb)	58	TC	125.0	125.0	141.6	120.0	120.0	135.9	114.3	114.3	129.5	107.9	107.9	122.3
		SHC	108.4	125.0	141.6	104.0	120.0	135.9	99.1	114.3	129.5	93.6	107.9	122.3	
		62	TC	125.1	125.1	147.2	120.1	120.1	141.4	114.4	114.4	134.7	108.0	108.0	127.2
		SHC	102.9	125.1	147.2	98.8	120.1	141.4	94.1	114.4	134.7	88.9	108.0	127.2	
		67	TC	132.8	132.8	133.0	126.5	126.5	130.8	119.6	119.6	128.2	111.8	111.8	125.1
		SHC	83.6	108.3	133.0	81.2	106.0	130.8	78.6	103.4	128.2	75.6	100.3	125.1	
		72	TC	142.8	142.8	142.8	136.3	136.3	136.3	129.1	129.1	129.1	121.1	121.1	121.1
		SHC	59.0	82.9	106.9	56.7	80.7	104.7	54.1	78.2	102.2	51.3	75.4	99.4	
		76	TC	-	149.4	149.4	-	142.8	142.8	-	135.1	135.1	-	126.5	126.5
		SHC	-	63.4	87.9	-	61.2	85.5	-	58.6	82.7	-	55.6	79.4	

LEGEND:

- Do not operate in this region
- Cfm - Cubic feet per minute (supply air)
- EAT(db) - Entering air temperature (dry bulb)
- EAT(wb) - Entering air temperature (wet bulb)
- SHC - Sensible heat capacity
- TC - Total capacity

Table 28 – COOLING CAPACITIES

2-STAGE COOLING

10 TONS

48TC*D12 (RTPF & Novation)			AMBIENT TEMPERATURE												
			85			95			105			115			
			EAT (db)			EAT (db)			EAT (db)			EAT (db)			
			75	80	85	75	80	85	75	80	85	75	80	85	
3000 Cfm	EAT (wb)	58	TC	107.6	107.6	121.9	102.5	102.5	116.2	96.8	96.8	109.7	90.5	90.5	102.6
			SHC	93.2	107.6	121.9	88.8	102.5	116.2	83.9	96.8	109.7	78.4	90.5	102.6
		62	TC	113.6	113.6	116.5	107.1	107.1	113.4	99.7	99.7	109.8	91.8	91.8	104.9
			SHC	84.6	100.6	116.5	81.5	97.4	113.4	78.0	93.9	109.8	73.7	89.3	104.9
		67	TC	124.4	124.4	124.4	118.4	118.4	118.4	111.5	111.5	111.5	103.3	103.3	103.3
			SHC	69.7	85.7	101.7	67.1	83.2	99.2	64.3	80.3	96.3	60.8	76.8	92.8
		72	TC	135.8	135.8	135.8	129.7	129.7	129.7	122.8	122.8	122.8	115	115	115
			SHC	54.3	70.4	86.6	52.0	68.1	84.2	49.3	65.4	81.6	46.4	62.5	78.6
		76	TC	-	145.3	145.3	-	139	139	-	131.9	131.9	-	124.1	124.1
			SHC	-	57.8	74.3	-	55.6	72.1	-	53.1	69.6	-	50.4	66.9
3500 Cfm	EAT (wb)	58	TC	114.2	114.2	129.4	108.9	108.9	123.4	102.9	102.9	116.6	96.3	96.3	109.1
			SHC	98.9	114.2	129.4	94.3	108.9	123.4	89.1	102.9	116.6	83.4	96.3	109.1
		62	TC	117.2	117.2	127.9	111.0	111.0	124.7	104.0	104.0	119.5	96.5	96.5	113.7
			SHC	91.1	109.5	127.9	88.1	106.4	124.7	83.9	101.7	119.5	79.3	96.5	113.7
		67	TC	127.8	127.8	127.8	121.7	121.7	121.7	114.5	114.5	114.5	106.6	106.6	106.6
			SHC	73.8	92.3	110.8	71.3	89.8	108.3	68.4	87.0	105.5	65.2	83.8	102.3
		72	TC	139.4	139.4	139.4	133.0	133.0	133	125.8	125.8	125.8	117.9	117.9	117.9
			SHC	56.0	74.6	93.1	53.7	72.2	90.8	51.0	69.6	88.2	48.1	66.7	85.4
		76	TC	-	148.8	148.8	-	142.2	142.2	-	134.9	134.9	-	126.8	126.8
			SHC	-	60.2	79.5	-	58.0	77.1	-	55.4	74.5	-	52.7	71.6
4000 Cfm	EAT (wb)	58	TC	119.0	119.0	134.9	114.0	114.0	129.2	108.0	108.0	122.4	101.1	101.1	114.6
			SHC	103.1	119.0	134.9	98.7	114.0	129.2	93.6	108.0	122.4	87.6	101.1	114.6
		62	TC	120.3	120.3	137.1	114.7	114.7	132.8	108.2	108.2	127.5	101.3	101.3	119.3
			SHC	96.5	116.8	137.1	93.0	112.9	132.8	88.9	108.2	127.5	83.2	101.3	119.3
		67	TC	130.5	130.5	130.5	124.1	124.1	124.1	116.8	116.8	116.8	108.7	108.7	111.1
			SHC	77.7	98.6	119.5	75.2	96.2	117.2	72.3	93.3	114.4	69.1	90.1	111.1
		72	TC	142.1	142.1	142.1	135.5	135.5	135.5	128.2	128.2	128.2	120.0	120.0	120.0
			SHC	57.6	78.4	99.3	55.2	76.1	97.1	52.5	73.6	94.6	49.7	70.7	91.8
		76	TC	-	151.4	151.4	-	144.7	144.7	-	137.1	137.1	-	-	-
			SHC	-	62.3	83.8	-	60.0	81.4	-	57.5	78.8	-	-	-
4500 Cfm	EAT (wb)	58	TC	123.0	123.0	139.5	117.8	117.8	133.6	111.9	111.9	126.9	105.3	105.3	119.3
			SHC	106.6	123.0	139.5	102.1	117.8	133.6	97.0	111.9	126.9	91.2	105.3	119.3
		62	TC	123.4	123.4	144.4	117.9	117.9	139.0	112.0	112.0	132.0	105.4	105.4	124.2
			SHC	100.9	122.7	144.4	96.9	117.9	139	92.1	112.0	132	86.6	105.4	124.2
		67	TC	132.6	132.6	132.6	126.0	126	126.0	118.7	118.7	122.9	110.4	110.4	119.6
			SHC	81.4	104.6	127.9	78.9	102.3	125.7	76.1	99.5	122.9	72.9	96.2	119.6
		72	TC	144.2	144.2	144.2	137.4	137.4	137.4	129.9	129.9	129.9	121.6	121.6	121.6
			SHC	59.0	82.1	105.2	56.6	79.8	103.1	54.0	77.3	100.7	51.1	74.5	98
		76	TC	-	153.4	153.4	-	146.6	146.6	-	138.9	138.9	-	-	-
			SHC	-	64.1	87.8	-	61.9	85.6	-	59.4	83	-	-	-
5000 Cfm	EAT (wb)	58	TC	126.5	126.5	143.3	121.2	121.2	137.4	115.1	115.1	130.5	108.4	108.4	122.8
			SHC	109.6	126.5	143.3	105.0	121.2	137.4	99.8	115.1	130.5	93.9	108.4	122.8
		62	TC	126.5	126.5	149.1	121.3	121.3	142.9	115.2	115.2	135.8	108.5	108.5	127.8
			SHC	104.0	126.5	149.1	99.7	121.3	142.9	94.7	115.2	135.8	89.1	108.5	127.8
		67	TC	134.2	134.2	135.9	127.5	127.5	133.8	120.1	120.1	131.0	111.9	111.9	127.6
			SHC	84.9	110.4	135.9	82.4	108.1	133.8	79.6	105.3	131	76.4	102.0	127.6
		72	TC	145.8	145.8	145.8	139.0	139.0	139.0	131.3	131.3	131.3	122.9	122.9	122.9
			SHC	60.3	85.6	110.8	57.9	83.4	108.9	55.3	81.0	106.6	52.5	78.2	104
		76	TC	-	155.1	155.1	-	148.2	148.2	-	-	-	-	-	-
			SHC	-	65.9	91.5	-	63.7	89.5	-	-	-	-	-	-

* See Minimum–Maximum Airflow Ratings in Table 6. Do not operate outside these limits.

LEGEND:

- Do not operate in this region
- Cfm - Cubic feet per minute (supply air)
- EAT(db) - Entering air temperature (dry bulb)
- EAT(wb) - Entering air temperature (wet bulb)
- SHC - Sensible heat capacity
- TC - Total capacity

48TC12 COOLING CAPACITIES, UNIT WITH HUMIDI-MIZER SYSTEM IN SUBCOOLING MODE										
TEMP (F) AIR ENT CONDENSER (Edb)		AIR ENTERING EVAPORATOR – CFM								
		3000/0.04			4000/0.06			5000/0.07		
		Air Entering Evaporator – Ewb (F)								
		72	67	62	72	67	62	72	67	62
75	TC	142.85	129.44	116.93	152.09	138.44	125.76	157.99	144.23	132.06
	SHC	58.38	74.88	91.58	67.96	89.45	111.02	76.63	102.94	127.93
	kW	7.19	6.97	6.79	6.92	7.12	7.35	7.45	7.22	7.02
85	TC	132.33	119.68	107.86	140.92	128.03	116.10	146.41	133.41	121.98
	SHC	48.44	65.56	82.83	57.37	79.50	101.68	65.65	92.58	118.12
	kW	7.98	7.77	7.58	7.72	7.92	8.14	8.25	8.01	7.82
95	TC	121.41	109.52	98.43	129.35	117.22	106.04	134.43	122.20	111.50
	SHC	38.19	55.92	73.78	46.47	69.22	92.01	54.34	81.92	107.96
	kW	8.87	8.66	8.48	8.61	8.80	9.03	9.14	8.90	8.71
105	TC	110.04	98.92	88.56	117.27	105.94	95.53	121.88	110.46	100.54
	SHC	27.59	45.94	64.39	35.16	58.57	81.98	42.56	70.82	97.40
	kW	9.86	9.66	9.48	9.61	9.79	10.02	10.12	9.89	9.70
115	TC	98.09	87.74	78.13	104.62	94.08	84.45	108.76	98.13	89.01
	SHC	16.52	35.47	54.53	23.37	47.44	71.46	30.32	59.25	86.31
	kW	10.95	10.76	10.60	10.72	10.89	11.10	11.19	10.98	10.81

48TC12 COOLING CAPACITIES, UNIT WITH HUMIDI-MIZER SYSTEM IN HOT GAS REHEAT MODE										
TEMP (F) AIR ENT CONDENSER (Edb)		AIR ENTERING EVAPORATOR – Ewb (F)								
		75 Dry Bulb 62.5 Wet Bulb (50% Relative)			75 Dry Bulb 64 Wet Bulb (56% Relative)			75 Dry Bulb 65.3 Wet Bulb (60% Relative)		
		Air Entering Evaporator – Cfm								
		3000	4000	5000	3000	4000	5000	3000	4000	5000
80	TC	44.78	39.41	31.89	53.22	49.44	43.38	60.56	58.12	53.32
	SHC	-0.44	-0.57	-0.69	-0.37	-0.51	-0.61	-0.33	-0.46	-0.56
	kW	6.96	6.77	6.52	7.26	7.13	6.91	7.54	7.45	7.27
75	TC	45.84	40.46	32.86	54.28	50.51	44.45	61.61	59.19	54.40
	SHC	0.53	0.40	0.29	0.60	0.47	0.37	0.64	0.52	0.42
	kW	6.77	6.56	6.29	7.11	6.95	6.72	7.41	7.31	7.12
70	TC	46.91	41.48	33.50	55.36	51.59	45.50	62.69	60.28	55.49
	SHC	1.51	1.38	1.27	1.57	1.45	1.35	1.61	1.50	1.40
	kW	6.54	6.32	6.02	6.90	6.74	6.49	7.23	7.13	6.92
60	TC	48.88	43.42	35.76	57.29	53.56	47.48	64.56	62.16	57.42
	SHC	3.44	3.34	3.24	3.51	3.40	3.31	3.55	3.45	3.37
	kW	6.45	6.16	6.70	6.93	6.72	6.39	7.38	7.24	6.96
50	TC	50.83	45.28	37.67	59.22	55.52	49.43	66.05	64.03	59.34
	SHC	5.38	5.29	5.20	5.45	5.36	5.28	5.48	5.40	5.33
	kW	6.46	6.01	6.34	6.98	6.71	6.29	8.15	7.38	7.02
40	TC	52.82	47.29	39.50	61.14	57.48	51.39	68.23	65.88	61.25
	SHC	7.32	7.24	7.20	7.38	7.31	7.24	7.43	7.36	7.29
	kW	6.29	6.09	6.12	7.05	6.72	6.29	7.78	7.55	7.10

LEGEND

- Edb – Entering Dry–Bulb
- Ewb – Entering Wet–Bulb
- kW – Compressor Motor Power Input
- ldb – Leaving Dry–Bulb
- lwb – Leaving Wet–Bulb
- SHC – Sensible Heat Capacity (1000 Btuh) Gross
- TC – Total Capacity (1000 Btuh) Gross

NOTES:

1. Direct interpolation is permissible. Do not extrapolate.
2. The following formulas may be used:

$$t_{ldb} = t_{edb} - \frac{\text{sensible capacity (Btuh)}}{1.10 \times \text{cfm}}$$

t_{lwb} = Wet–bulb temperature corresponding to enthalpy of air leaving evaporator coil (h_{lwb})

$$h_{lwb} = h_{ewb} - \frac{\text{total capacity (Btuh)}}{4.5 \times \text{cfm}}$$

Where: h_{ewb} = Enthalpy of air entering evaporator coil

Table 30 – COOLING CAPACITIES

2-STAGE COOLING

12.5 TONS

48TC*D14 (RTPF & Novation)			AMBIENT TEMPERATURE												
			85			95			105			115			
			EAT (db)			EAT (db)			EAT (db)			EAT (db)			
			75	80	85	75	80	85	75	80	85	75	80	85	
3600 Cfm	EAT (wb)	58	TC	127.6	127.6	142.9	121.7	121.7	137.6	115.0	115.0	130	108.3	108.3	122.6
			SHC	110.3	126.6	142.9	105.8	121.7	137.6	99.9	115.0	130	94.1	108.3	122.6
		62	TC	136.1	136.1	136.1	131.1	131.1	131.1	123.8	123.8	124.5	114.9	114.9	120.3
			SHC	96.6	112.8	129.0	94.7	111.2	127.7	91.4	108.0	124.5	87.3	103.8	120.3
		67	TC	146.2	146.2	146.2	142.0	142.0	142.0	136.2	136.2	136.2	128.8	128.8	128.8
			SHC	78.5	94.4	110.3	76.9	93.1	109.2	74.7	91.0	107.3	71.7	88.1	104.6
		72	TC	155.9	155.9	155.9	152.4	152.4	152.4	147.2	147.2	147.2	140.1	140.1	140.1
			SHC	60.1	76.6	93.2	58.7	75.2	91.7	56.8	73.3	89.7	54.2	70.6	87.0
		76	TC	-	163.0	163	-	160.0	160	-	155.1	155.1	-	148.2	148.2
			SHC	-	62.0	81.8	-	61.1	80.9	-	59.5	79.3	-	57.0	76.3
4200 Cfm	EAT (wb)	58	TC	132.2	132.2	149.5	128.2	128.2	144.9	121.9	121.9	137.8	115.0	115.0	130.1
			SHC	115.0	132.2	149.5	111.5	128.2	144.9	106.0	121.9	137.8	99.9	115.0	130.1
		62	TC	139.6	139.6	139.6	134.7	134.7	138	128.0	128.0	135.6	119.1	119.1	131.2
			SHC	102.5	120.8	139	100.8	119.4	138	98.1	116.8	135.6	93.9	112.6	131.2
		67	TC	149.5	149.5	149.5	145.4	145.4	145.4	139.6	139.6	139.6	132.1	132.1	132.1
			SHC	81.8	99.6	117.4	80.6	98.7	116.8	78.5	96.9	115.2	75.7	94.3	112.8
		72	TC	159.0	159.0	159.0	155.5	155.5	155.5	150.3	150.3	150.3	143.1	143.1	143.1
			SHC	61.4	79.6	97.8	60.2	78.5	96.8	58.3	76.7	95	55.8	74.2	92.5
		76	TC	-	165.7	165.7	-	162.8	162.8	-	157.8	157.8	-	150.8	150.8
			SHC	-	64.6	87.7	-	63.5	86.3	-	61.5	83.3	-	58.9	79.9
4800 Cfm	EAT (wb)	58	TC	136.7	136.7	154.5	133.0	133.0	150.3	127.7	127.7	144.3	120.6	120.6	136.4
			SHC	118.9	136.7	154.5	115.7	133.0	150.3	111.0	127.7	144.3	104.9	120.6	136.4
		62	TC	142.2	142.2	147.8	137.4	137.4	147.1	131.0	131.0	144.7	122.8	122.8	140.3
			SHC	107.7	127.8	147.8	106.2	126.7	147.1	103.6	124.2	144.7	99.3	119.8	140.3
		67	TC	152.1	152.1	152.1	148.0	148	148	142.2	142.2	142.2	134.6	134.6	134.6
			SHC	84.8	104.3	123.7	83.8	103.8	123.7	82.0	102.3	122.6	79.4	99.9	120.4
		72	TC	161.3	161.3	161.3	157.8	157.8	157.8	152.5	152.5	152.5	145.4	145.4	145.4
			SHC	62.6	82.2	101.9	61.4	81.4	101.3	59.7	79.7	99.8	57.2	77.3	97.5
		76	TC	-	167.7	167.7	-	164.9	164.9	-	159.9	159.9	-	152.8	152.8
			SHC	-	66.4	91.4	-	65	89.2	-	63.1	86.4	-	60.5	83.1
5400 Cfm	EAT (wb)	58	TC	140.5	140.5	158.8	136.9	136.9	154.7	131.8	131.8	149	125.2	125.2	141.6
			SHC	122.2	140.5	158.8	119	136.9	154.7	114.7	131.8	149	108.9	125.2	141.6
		62	TC	144.3	144.3	155.7	139.6	139.6	155	133.5	133.5	152.4	125.8	125.8	147.8
			SHC	112.2	133.9	155.7	110.9	132.9	155	108.1	130.2	152.4	103.9	125.8	147.8
		67	TC	154.2	154.2	154.2	150.0	150.0	150.0	144.2	144.2	144.2	136.7	136.7	136.7
			SHC	87.6	108.6	129.6	86.8	108.5	130.1	85.2	107.3	129.4	82.8	105.1	127.4
		72	TC	163.1	163.1	163.1	159.7	159.7	159.7	154.3	154.3	154.3	147.1	147.1	147.1
			SHC	63.6	84.6	105.6	62.5	83.9	105.4	60.8	82.5	104.2	58.4	80.2	102
		76	TC	-	169.3	169.3	-	166.5	166.5	-	161.5	161.5	-	154.2	154.2
			SHC	-	67.6	93.7	-	66.4	91.7	-	64.5	89.2	-	61.9	86.1
6000 Cfm	EAT (wb)	58	TC	143.6	143.6	162.3	140.1	140.1	158.3	135.1	135.1	152.7	128.7	128.7	145.5
			SHC	124.9	143.6	162.3	121.8	140.1	158.3	117.5	135.1	152.7	111.9	128.7	145.5
		62	TC	146.1	146.1	162.4	141.7	141.7	161.5	135.6	135.6	159.2	128.8	128.8	151.2
			SHC	116.1	139.3	162.4	114.7	138.1	161.5	112.1	135.6	159.2	106.4	128.8	151.2
		67	TC	155.8	155.8	155.8	151.6	151.6	151.6	145.9	145.9	145.9	138.3	138.3	138.3
			SHC	90.1	112.6	135	89.6	112.8	136	88.3	112.0	135.8	85.9	110.0	134.1
		72	TC	164.5	164.5	164.5	161.2	161.2	161.2	155.8	155.8	155.8	148.5	148.5	148.5
			SHC	64.5	86.7	108.9	63.5	86.3	109.1	61.9	85.1	108.2	59.6	82.9	106.3
		76	TC	-	170.6	170.6	-	167.8	167.8	-	162.8	162.8	-	155.5	155.5
			SHC	-	68.7	95.8	-	67.5	94.1	-	65.7	91.8	-	63.3	88.8

* See Minimum–Maximum Airflow Ratings in Table 6. Do not operate outside these limits.

LEGEND:

- Do not operate in this region
- Cfm - Cubic feet per minute (supply air)
- EAT(db) - Entering air temperature (dry bulb)
- EAT(wb) - Entering air temperature (wet bulb)
- SHC - Sensible heat capacity
- TC - Total capacity

Table 31 – COOLING CAPACITIES

2-STAGE COOLING

12.5 TONS

48TC14 COOLING CAPACITIES, UNIT WITH HUMIDI-MIZER SYSTEM IN SUBCOOLING MODE										
TEMP (F) AIR ENT CONDENSER (Edb)		AIR ENTERING EVAPORATOR – CFM								
		3750/0.02			5000/0.06			6250/0.05		
		Air Entering Evaporator – Ewb (F)								
		72	67	62	72	67	62	72	67	62
75	TC	183.66	166.86	151.43	194.90	177.83	162.05	201.97	184.84	170.53
	SHC	79.39	100.52	121.91	91.70	119.42	147.05	102.94	137.00	166.71
	kW	9.82	9.63	9.46	9.58	9.76	9.96	10.04	9.84	9.67
85	TC	172.71	156.78	142.09	183.32	167.13	152.17	189.98	173.73	160.25
	SHC	69.03	90.92	112.95	80.69	109.17	137.51	91.49	126.33	156.65
	kW	10.82	10.63	10.45	10.57	10.76	10.96	11.04	10.84	10.67
95	TC	161.37	146.24	132.38	171.36	156.04	141.86	177.62	162.22	149.50
	SHC	58.44	81.04	103.77	69.42	98.67	127.71	79.83	115.45	146.15
	kW	11.92	11.73	11.56	11.68	11.86	12.05	12.14	11.93	11.77
105	TC	149.57	135.32	122.21	158.89	144.45	131.10	164.74	150.27	138.35
	SHC	47.57	70.92	94.32	57.85	87.91	117.61	67.79	104.26	135.30
	kW	13.12	12.94	12.77	12.89	13.06	13.24	13.32	13.13	12.97
115	TC	137.22	123.88	111.55	145.85	132.33	119.84	151.27	137.71	126.67
	SHC	36.31	60.47	84.57	45.87	76.77	107.19	55.34	92.66	123.98
	kW	14.41	14.25	14.10	14.20	14.35	14.53	14.59	14.42	14.28

48TC14 COOLING CAPACITIES, UNIT WITH HUMIDI-MIZER SYSTEM IN HOT GAS REHEAT MODE										
TEMP (F) AIR ENT CONDENSER (Edb)		AIR ENTERING EVAPORATOR – Ewb (F)								
		75 Dry Bulb 62.5 Wet Bulb (50% Relative)			75 Dry Bulb 64 Wet Bulb (56% Relative)			75 Dry Bulb 65.3 Wet Bulb (60% Relative)		
		Air Entering Evaporator – Cfm								
		3750	5000	6250	3750	5000	6250	3750	5000	6250
80	TC	52.42	45.88	36.99	62.64	58.07	51.07	71.56	68.64	63.23
	SHC	-0.39	-0.54	-0.67	-0.31	-0.46	-0.58	-0.26	-0.40	-0.52
	kW	9.65	9.39	9.07	9.97	9.77	9.50	10.25	10.11	9.89
75	TC	53.45	46.63	36.10	63.77	59.11	51.87	72.76	69.80	64.31
	SHC	0.59	0.44	0.30	0.67	0.52	0.40	0.72	0.58	0.47
	kW	9.09	8.83	8.49	9.39	9.20	8.94	9.67	9.53	9.32
70	TC	54.33	46.91	37.58	64.77	60.01	52.30	73.80	70.80	65.24
	SHC	1.56	1.41	1.29	1.64	1.50	1.38	1.70	1.56	1.45
	kW	8.81	8.53	8.62	9.15	8.94	8.65	9.46	9.31	9.08
60	TC	55.47	49.48	40.48	66.62	62.07	54.88	75.68	72.76	67.28
	SHC	3.50	3.38	3.27	3.59	3.47	3.36	3.65	3.52	3.42
	kW	8.36	8.84	8.98	9.88	9.56	9.10	9.83	9.64	9.31
50	TC	58.33	51.72	42.81	68.72	63.93	55.84	77.74	74.77	69.24
	SHC	5.47	5.35	5.24	5.54	5.43	5.32	5.60	5.49	5.39
	kW	8.98	9.25	9.43	9.33	8.97	8.73	9.55	9.33	9.70
40	TC	60.33	53.69	46.89	70.67	65.93	49.83	79.46	76.62	71.24
	SHC	7.42	7.31	7.22	7.49	7.39	7.23	7.55	7.45	7.37
	kW	9.16	9.88	9.06	9.50	9.05	9.47	10.31	10.00	9.48

LEGEND

- Edb – Entering Dry–Bulb
- Ewb – Entering Wet–Bulb
- kW – Compressor Motor Power Input
- ldb – Leaving Dry–Bulb
- lwb – Leaving Wet–Bulb
- SHC – Sensible Heat Capacity (1000 Btuh) Gross
- TC – Total Capacity (1000 Btuh) Gross

NOTES:

1. Direct interpolation is permissible. Do not extrapolate.
2. The following formulas may be used:

$$t_{ldb} = t_{edb} - \frac{\text{sensible capacity (Btuh)}}{1.10 \times \text{cfm}}$$

t_{lwb} = Wet–bulb temperature corresponding to enthalpy of air leaving evaporator coil (h_{lwb})

$$h_{lwb} = h_{ewb} - \frac{\text{total capacity (Btuh)}}{4.5 \times \text{cfm}}$$

Where: h_{ewb} = Enthalpy of air entering evaporator coil

Table 32 – COOLING CAPACITIES

2-STAGE COOLING

15 TONS

48TC*D16 (RTPF)			Ambient Temperature												
			85			95			105			115			
			EA (dB)			EA (dB)			EA (dB)			EA (dB)			
			75	80	85	75	80	85	75	80	85	75	80	85	
4500 Cfm	EAT (wb)	58	THC	156.6	156.6	175.2	149.4	149.4	169.1	141.6	141.6	160.2	133.3	133.3	150.9
			SHC	134.7	154.9	175.2	129.8	149.4	169.1	123.0	141.6	160.2	115.7	133.3	150.9
		62	THC	166.7	166.7	166.9	158.0	158.0	162.6	147.6	147.6	157.2	136.8	136.8	150.3
			SHC	122.8	144.9	166.9	118.6	140.6	162.6	113.5	135.3	157.2	107.4	128.8	150.3
		67	THC	184.1	184.1	184.1	175.6	175.6	175.6	165.6	165.6	165.6	154.5	154.5	154.5
	SHC		101.6	123.7	145.7	98.1	120.2	142.3	94.0	116.1	138.2	89.4	111.5	133.6	
	72	THC	200.3	200.3	200.3	192.0	192.0	192.0	182.9	182.9	182.9	172.2	172.2	172.2	
		SHC	78.7	101.1	123.5	75.5	97.9	120.2	72.1	94.4	116.7	68.2	90.5	112.7	
	76	THC	-	211.4	211.4	-	203.1	203.1	-	193.8	193.8	-	183.9	183.9	
		SHC	-	82.2	107.0	-	79.3	103.8	-	76.0	100.2	-	72.6	96.5	
5250 Cfm	EAT (wb)	58	THC	165.2	165.2	186.9	158.2	158.2	179.0	150.0	150.0	169.7	141.3	141.3	160.0
			SHC	143.5	165.2	186.9	137.4	158.2	179.0	130.2	150.0	169.7	122.7	141.3	160.0
		62	THC	172.3	172.3	181.7	163.4	163.4	176.9	153.1	153.1	169.3	143.4	143.4	161.4
			SHC	131.6	156.6	181.7	127.1	152.0	176.9	120.5	144.9	169.3	114.1	137.8	161.4
		67	THC	189.5	189.5	189.5	180.9	180.9	180.9	170.7	170.7	170.7	159.1	159.1	159.1
	SHC		107.2	132.4	157.5	103.8	129.0	154.1	99.9	125.1	150.4	95.3	120.6	145.8	
	72	THC	205.0	205.0	205.0	196.5	196.5	196.5	187.1	187.1	187.1	176.4	176.4	176.4	
		SHC	80.9	106.1	131.3	77.7	102.9	128.1	74.4	99.5	124.7	70.6	95.8	121.0	
	76	THC	-	215.4	215.4	-	206.8	206.8	-	197.1	197.1	-	186.9	186.9	
		SHC	-	85.0	113.0	-	82.0	109.8	-	78.8	106.4	-	75.4	102.8	
6000 Cfm	EAT (wb)	58	THC	172.7	172.7	195.4	165.5	165.5	187.3	157.1	157.1	177.8	148.1	148.1	167.7
			SHC	150.0	172.7	195.4	143.8	165.5	187.3	136.4	157.1	177.8	128.6	148.1	167.7
		62	THC	176.6	176.6	195.7	168.1	168.1	187.6	158.9	158.9	180.2	148.9	148.9	172.1
			SHC	139.6	167.7	195.7	133.2	160.4	187.6	127.1	153.7	180.2	120.7	146.4	172.1
		67	THC	193.6	193.6	193.6	184.8	184.8	184.8	174.7	174.7	174.7	162.7	162.7	162.7
	SHC		112.3	140.3	168.3	108.9	137.0	165.2	105.2	133.5	161.7	100.7	129.0	157.3	
	72	THC	208.4	208.4	208.4	199.6	199.6	199.6	190.2	190.2	190.2	179.5	179.5	179.5	
		SHC	82.7	110.5	138.3	79.6	107.3	135.1	76.2	104.0	131.8	72.6	100.6	128.5	
	76	THC	-	218.2	218.2	-	209.5	209.5	-	199.5	199.5	-	189.0	189.0	
		SHC	-	87.5	118.6	-	84.5	115.2	-	81.1	111.3	-	77.5	107.3	
6750 Cfm	EAT (wb)	58	THC	178.8	178.8	202.4	171.6	171.6	194.2	163.1	163.1	184.6	153.8	153.8	174.1
			SHC	155.3	178.8	202.4	149.0	171.6	194.2	141.6	163.1	184.6	133.5	153.8	174.1
		62	THC	181.0	181.0	203.6	173.0	173.0	197.5	163.8	163.8	190.1	153.9	153.9	181.1
			SHC	144.1	173.9	203.6	139.1	168.3	197.5	133.3	161.7	190.1	126.7	153.9	181.1
		67	THC	196.8	196.8	196.8	187.9	187.9	187.9	177.7	177.7	177.7	165.5	165.5	167.9
	SHC		117.0	147.7	178.4	113.7	144.5	175.4	110.1	141.1	172.2	105.6	136.8	167.9	
	72	THC	211.0	211.0	211.0	202.2	202.2	202.2	192.5	192.5	192.5	181.8	181.8	181.8	
		SHC	84.3	114.5	144.7	81.2	111.5	141.7	77.9	108.1	138.4	74.4	104.9	135.4	
	76	THC	-	220.2	220.2	-	211.5	211.5	-	201.3	201.3	-	190.6	190.6	
		SHC	-	89.5	122.8	-	86.4	119.4	-	83.0	115.4	-	79.4	111.5	
7500 Cfm	EAT (wb)	58	THC	183.9	183.9	208.2	176.6	176.6	199.8	168.2	168.2	190.3	158.6	158.6	179.5
			SHC	159.7	183.9	208.2	153.3	176.6	199.8	146.0	168.2	190.3	137.7	158.6	179.5
		62	THC	185.1	185.1	212.5	177.1	177.1	206.2	168.3	168.3	197.9	158.7	158.7	186.7
			SHC	149.5	181.0	212.5	144.5	175.4	206.2	138.7	168.3	197.9	130.8	158.7	186.7
		67	THC	199.3	199.3	199.3	190.3	190.3	190.3	180.0	180.0	181.7	167.8	167.8	177.8
	SHC		121.3	154.6	187.9	118.1	151.6	185.1	114.4	148.1	181.7	110.1	144.0	177.8	
	72	THC	213.0	213.0	213.0	204.1	204.1	204.1	194.2	194.2	194.2	183.5	183.5	183.5	
		SHC	85.8	118.2	150.5	82.7	115.2	147.7	79.4	111.9	144.4	76.0	108.8	141.6	
	76	THC	-	221.9	221.9	-	213.0	213.0	-	202.7	202.7	-	191.8	191.8	
		SHC	-	91.2	126.5	-	88.2	123.1	-	84.7	119.2	-	81.2	115.3	

* See Minimum–Maximum Airflow Ratings in Table 6. Do not operate outside these limits.

LEGEND:

- Do not operate in this region
- Cfm – Cubic feet per minute (supply air)
- EAT(db) – Entering air temperature (dry bulb)
- EAT(wb) – Entering air temperature (wet bulb)
- SHC – Sensible heat capacity
- TC – Total capacity

48TC*E16 Cooling Capacities, Subcooling Mode										
TEMP (F) AIR ENT CONDENSER (Edb)		AIR ENTERING EVAPORATOR – CFM								
		4500/0.02			6000/0.06			7500/0.05		
		Air Entering Evaporator – Ewb (F)								
		72	67	62	72	67	62	72	67	62
75	TC	204.4	186.3	168.2	218.4	199.6	180.9	229.6	210.4	191.2
	SHC	98.9	118.1	137.2	114.8	133.7	152.6	127.6	146.2	164.9
	kW	11.57	11.22	10.77	11.78	11.45	11.00	12.06	11.64	11.35
85	TC	189.2	171.7	154.1	203.0	184.8	166.7	214.1	195.5	176.9
	SHC	79.5	103.4	127.3	96.5	120.2	144.0	110.2	133.7	157.3
	kW	12.59	12.24	11.81	12.81	12.50	12.03	13.05	12.66	12.47
95	TC	174.0	157.0	140.0	187.6	170.1	152.5	198.6	180.6	162.7
	SHC	60.0	88.7	117.5	78.2	106.8	135.3	92.9	121.3	149.7
	kW	13.68	13.35	12.86	13.91	13.57	13.05	14.15	13.75	13.47
105	TC	158.8	142.3	125.8	172.2	155.3	138.3	183.1	165.7	148.4
	SHC	40.5	74.1	107.7	59.9	93.3	126.7	75.5	108.8	142.0
	kW	14.67	14.41	13.88	14.90	14.55	14.10	15.15	14.73	14.53
115	TC	143.6	127.6	111.7	156.8	140.5	124.1	167.6	150.9	134.2
	SHC	21.0	59.4	97.8	41.6	79.9	118.1	58.1	96.3	134.2
	kW	15.77	15.38	14.88	15.88	15.65	15.10	16.12	15.84	15.54

48TC*E 16 COOLING CAPACITIES, HOT GAS REHEAT MODE										
TEMP (F) AIR ENT CONDENSER Edb)		AIR ENTERING EVAPORATOR – Ewb (F)								
		75 Dry Bulb 62.5 Wet Bulb (50% Relative)			75 Dry Bulb 64 Wet Bulb (56% Relative)			75 Dry Bulb 65.3 Wet Bulb (60% Relative)		
		Air Entering Evaporator – Cfm								
		4500	6000	7500	4500	6000	7500	4500	6000	7500
80	TC	83.75	84.85	88.95	86.65	91.90	92.90	87.90	91.75	96.30
	SHC	37.50	42.80	55.10	30.90	40.40	44.50	24.80	29.30	34.10
	kW	10.50	11.49	11.60	10.56	10.65	11.70	11.60	11.72	11.77
75	TC	85.00	86.00	90.50	88.05	93.60	94.65	89.20	93.45	97.85
	SHC	40.00	45.00	57.30	33.20	42.30	46.90	26.90	31.50	36.30
	kW	10.16	11.15	11.25	10.21	10.31	11.33	11.26	11.35	11.42
70	TC	86.15	87.35	91.50	89.20	94.30	96.10	90.40	94.10	98.95
	SHC	42.10	47.50	59.80	35.50	45.30	49.50	29.50	33.90	38.70
	kW	9.84	10.83	10.94	10.02	10.13	11.03	10.95	11.05	11.12
60	TC	88.90	90.10	94.25	92.00	97.10	98.20	93.20	96.90	101.75
	SHC	46.80	52.30	64.60	40.20	50.10	54.10	34.10	38.60	43.40
	kW	9.37	10.36	10.44	9.42	9.52	10.55	10.45	10.57	10.64
50	TC	91.70	92.80	97.00	94.80	99.90	101.00	96.10	99.70	104.20
	SHC	51.50	57.10	69.40	44.80	54.80	58.90	38.70	43.20	49.00
	kW	9.12	10.09	10.16	9.17	9.28	10.26	10.17	10.26	10.32
40	TC	94.45	95.60	99.80	97.45	102.55	103.70	98.65	102.35	107.00
	SHC	56.30	61.40	73.70	49.70	59.20	63.30	43.60	48.10	52.90
	kW	9.05	10.02	10.10	9.10	9.21	10.18	10.11	10.20	10.26

LEGEND

- Edb** – Entering Dry– Bulb
- Ewb** – Entering Wet– Bulb
- kW** – Compressor Motor Power Input
- ldb** – Leaving Dry– Bulb
- lwb** – Leaving Wet– Bulb
- SHC** – Sensible Heat Capacity (1000 Btuh) Gross
- TC** – Total Capacity (1000 Btuh) Gross

NOTES:

1. Direct interpolation is permissible. Do not extrapolate.
2. The following formulas may be used:

$$t_{ldb} = t_{edb} - \frac{\text{sensible capacity (Btuh)}}{1.10 \times \text{cfm}}$$

t_{lwb} = Wet–bulb temperature corresponding to enthalpy of air leaving evaporator coil (h_{lwb})

$$h_{lwb} = h_{ewb} - \frac{\text{total capacity (Btuh)}}{4.5 \times \text{cfm}}$$

Where: h_{ewb} = Enthalpy of air entering evaporator coil

Table 34 – STATIC PRESSURE ADDERS (IN. WG) (FACTORY OPTIONS AND/OR ACCESSORIES)

Humidi-MiZer

3-6 TONS									
CFM	1000	1250	1500	1750	2000	2250	2500	2750	3000
3 Tons	0.04	0.052	0.07	-	-	-	-	-	-
4 Tons	-	0.106	0.138	0.172	0.21	-	-	-	-
5 Tons	-	-	0.138	0.172	0.21	0.252	0.30	-	-
6 Tons	-	-	-	0.112	0.125	0.161	0.19	0.22	0.25

7.5-12.5 TONS																
CFM	2250	2500	2750	3000	3250	3500	3750	4000	4250	4500	4750	5000	5250	5500	5750	6000
7.5 Tons	0.12	0.14	0.16	0.19	0.21	0.23	0.26	-	-	-	-	-	-	-	-	-
8.5 Tons	-	0.11	0.12	0.13	0.15	0.17	0.18	0.20	0.22	-	-	-	-	-	-	-
10 Tons	-	-	-	0.13	0.15	0.17	0.18	0.20	0.22	0.24	0.26	0.28	-	-	-	-
12.5 Tons	-	-	-	-	-	0.17	0.18	0.20	0.22	0.24	0.26	0.28	0.31	0.33	0.36	0.39

15 TONS															
CFM	4000	4250	4500	4750	5000	5250	5500	5750	6000	6250	6500	6750	7000	7250	
15 Tons	0.06	0.07	0.07	0.08	0.08	0.09	0.10	0.10	0.11	0.12	0.12	0.13	0.14	0.15	



ECONOMIZER, BAROMETRIC RELIEF AND PE PERFORMANCE

Vertical Application

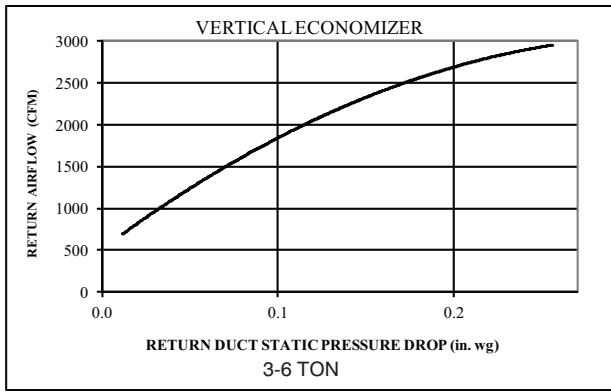

Fig. 16 - Return Air Pressure Drop

C11238

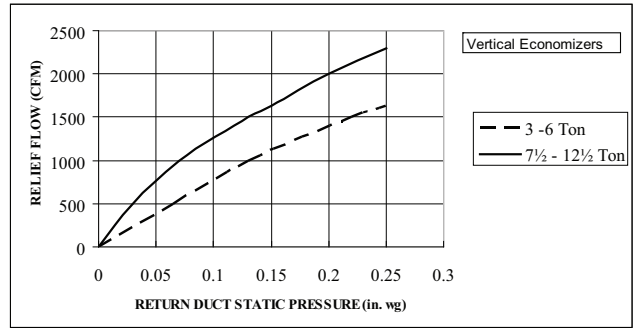

Fig. 19 - Barometric Relief Flow Capacity

C08073

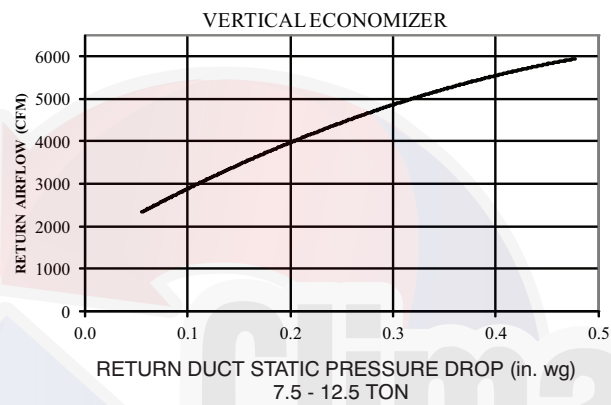

Fig. 17 - Return Air Pressure Drop

C11240

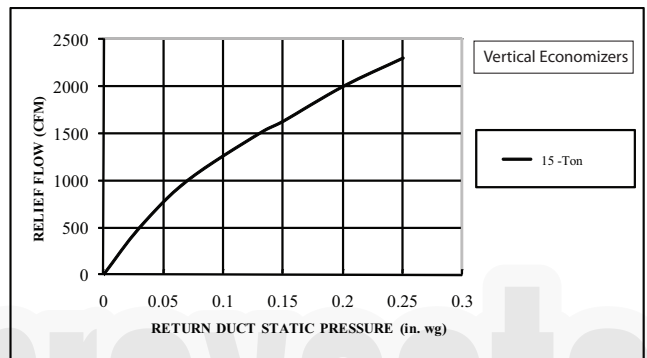

Fig. 20 - Barometric Relief Flow-Vertical 15 Ton

C101122

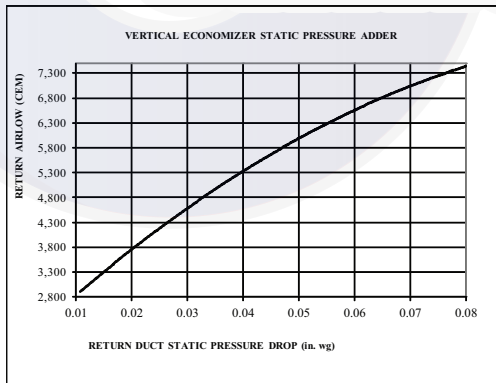

Fig. 18 - Return Air Pressure Drop-Vertical 15 Tons

C11257

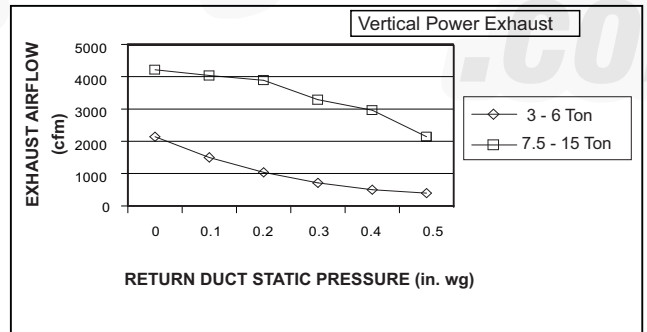

Fig. 21 - Vertical Power Exhaust Performance

C11248

All above data for both standard and ultra low leak models, where available.

ECONOMIZER, BAROMETRIC RELIEF AND PE PERFORMANCE (cont.)

Horizontal Application

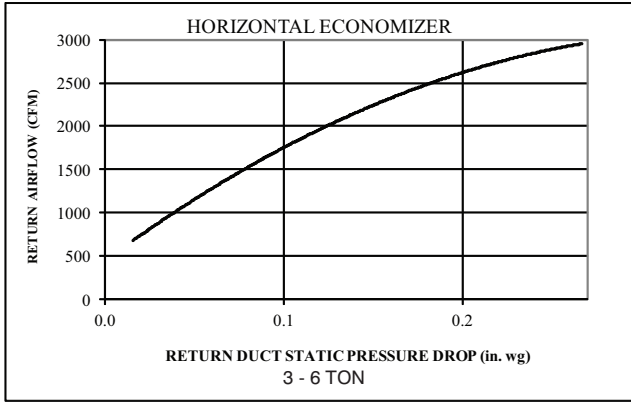

Fig. 22 - Return Air Pressure Drop

C11239

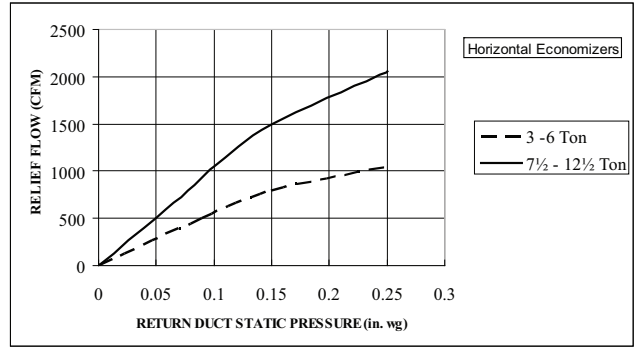

Fig. 25 - Barometric Relief Flow Capacity

C08070

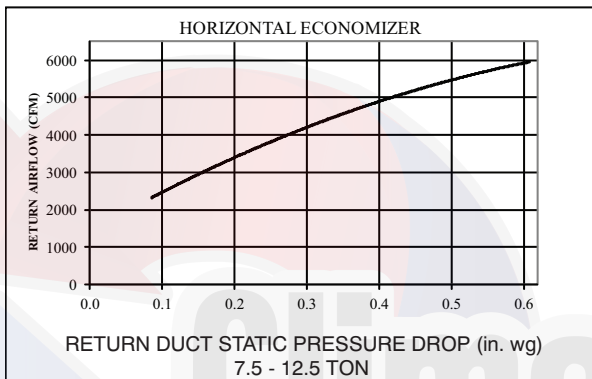

Fig. 23 - Return Air Pressure Drop

C11241

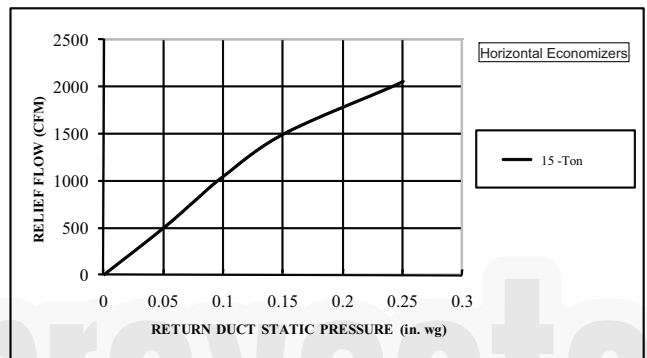

Fig. 26 - Barometric Relief Flow-Horizontal 15 Ton

C101120

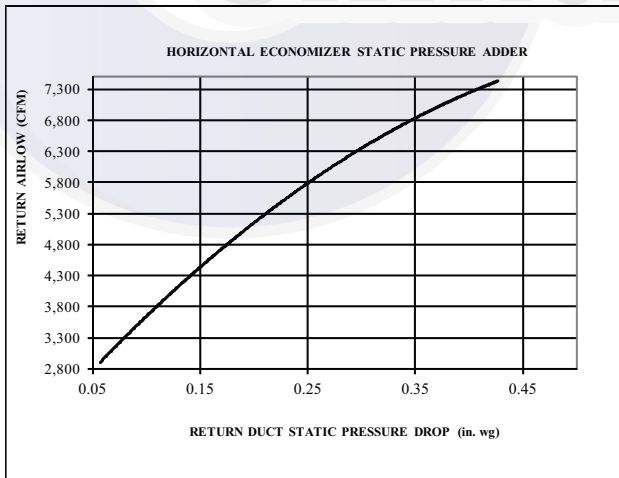

Fig. 24 - Return Air Pressure Drop-Horizontal 15 Ton

C11258

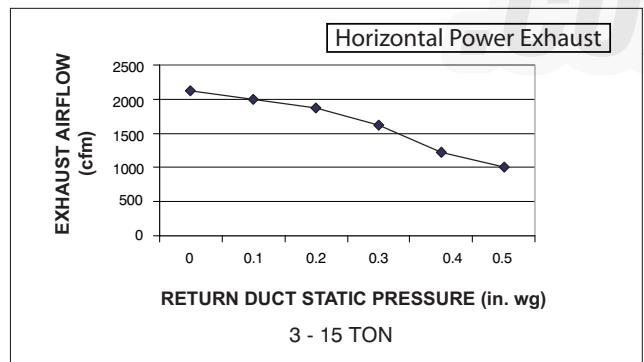

Fig. 27 - Horizontal Power Exhaust Performance

C08012

GENERAL FAN PERFORMANCE NOTES

1. Interpolation is permissible. Do not extrapolate.
2. External static pressure is the static pressure difference between the return duct and the supply duct plus the static pressure caused by any FIOPs or accessories.
3. Tabular data accounts for pressure loss due to clean filters, unit casing, and wet coils. Factory options and accessories may add static pressure losses. Selection software is available, through your salesperson, to help you select the best motor/drive combination for your application.
4. The Fan Performance tables offer motor/drive recommendations. In cases when two motor/drive combinations would work, Carrier recommended the lower horsepower option.
5. For information on the electrical properties of Carrier motors, please see the Electrical information section of this book.
6. For more information on the performance limits of Carrier motors, see the application data section of this book.
7. The EPACT (Energy Policy Act of 1992) regulates energy requirements for specific types of indoor fan motors. Motors regulated by EPACT include any general purpose, T-frame (three-digit, 143 and larger), single-speed, foot mounted, polyphase, squirrel cage induction motors of NEMA (National Electrical Manufacturers Association) design A and B, manufactured for use in the United States. Ranging from 1 to 200 Hp, these continuous-duty motors operate on 230 and 460 volt, 60 Hz power. If a motor does not fit into these specifications, the motor does not have to be replaced by an EPACT compliant energy efficient motor. Variable speed motors are exempt from EPACT compliance requirements. Therefore, the indoor fan motors for Carrier 48TC**04-16 units are exempt from these requirements.



FAN PERFORMANCE

Table 35 – 48TC04**

1 PHASE

3 TON HORIZONTAL SUPPLY

CFM	AVAILABLE EXTERNAL STATIC PRESSURE (in. wg)									
	0.2		0.4		0.6		0.8		1.0	
	RPM	BHP	RPM	BHP	RPM	BHP	RPM	BHP	RPM	BHP
	Field Supplied Drive¹		Standard Static Option				Medium Static Option			
900	553	0.14	681	0.22	782	0.32	870	0.42	948	0.53
975	575	0.16	700	0.25	801	0.35	888	0.46	965	0.57
1050	597	0.18	720	0.28	820	0.38	906	0.49	983	0.61
1125	620	0.21	741	0.31	839	0.42	925	0.54	1001	0.66
1200	643	0.23	762	0.34	859	0.46	944	0.58	1020	0.71
1275	667	0.27	783	0.38	879	0.50	963	0.63	1038	0.76
1350	691	0.30	805	0.42	900	0.55	983	0.68	1057	0.82
1425	715	0.34	827	0.47	920	0.60	1002	0.74	1076	0.88
1500	740	0.38	849	0.52	941	0.66	1023	0.80	1096	0.95

CFM	AVAILABLE EXTERNAL STATIC PRESSURE (in. wg)									
	1.2		1.4		1.6		1.8		2.0	
	RPM	BHP	RPM	BHP	RPM	BHP	RPM	BHP	RPM	BHP
	Medium Static Option				Field Supplied Drive²					
900	1019	0.64	1084	0.76	1146	0.89	1203	1.02	1258	1.16
975	1036	0.69	1101	0.81	1162	0.94	1219	1.08	–	–
1050	1053	0.74	1118	0.86	1179	1.00	1236	1.14	–	–
1125	1071	0.79	1135	0.92	1196	1.06	1253	1.20	–	–
1200	1089	0.84	1153	0.98	1213	1.12	–	–	–	–
1275	1107	0.90	1171	1.04	1231	1.19	–	–	–	–
1350	1126	0.96	1189	1.11	–	–	–	–	–	–
1425	1144	1.03	1208	1.18	–	–	–	–	–	–
1500	1163	1.10	–	–	–	–	–	–	–	–

NOTE: For more information, see General Fan Performance Notes.

Boldface indicates field supplied drive is required.

1. Recommend using field supplied fan pulley (part no. KR11AG006) and belt (part no. KR30AE039).
2. Recommend using field supplied motor pulley (part no. KR11HY161) and belt (part no. KR30AE035).

Table 36 – 48TC04**

1 PHASE

3 TON VERTICAL SUPPLY

CFM	AVAILABLE EXTERNAL STATIC PRESSURE (in. wg)									
	0.2		0.4		0.6		0.8		1.0	
	RPM	BHP	RPM	BHP	RPM	BHP	RPM	BHP	RPM	BHP
	Field Supplied Drive¹		Standard Static Option				Medium Static Option			
900	567	0.15	688	0.22	786	0.30	871	0.37	947	0.44
975	591	0.17	710	0.26	807	0.34	891	0.42	966	0.49
1050	615	0.20	732	0.29	828	0.38	911	0.47	985	0.55
1125	641	0.23	755	0.33	849	0.42	931	0.52	1005	0.61
1200	666	0.26	778	0.37	871	0.47	952	0.57	1025	0.67
1275	693	0.29	802	0.41	893	0.53	974	0.63	1046	0.74
1350	719	0.33	826	0.46	916	0.58	995	0.70	1067	0.81
1425	746	0.38	850	0.51	939	0.64	1017	0.76	1088	0.89
1500	773	0.42	875	0.57	963	0.70	1040	0.84	1110	0.96

CFM	AVAILABLE EXTERNAL STATIC PRESSURE (in. wg)									
	1.2		1.4		1.6		1.8		2.0	
	RPM	BHP	RPM	BHP	RPM	BHP	RPM	BHP	RPM	BHP
	Medium Static Option				Field Supplied Drive²					
900	1016	0.51	1080	0.57	1139	0.64	1195	0.71	1249	0.77
975	1034	0.57	1098	0.64	1157	0.72	1213	0.79	1266	0.86
1050	1053	0.63	1116	0.71	1176	0.79	1231	0.87	1284	0.95
1125	1073	0.70	1135	0.79	1194	0.87	1250	0.96	1302	1.04
1200	1093	0.77	1155	0.87	1213	0.96	1268	1.05	1321	1.14
1275	1113	0.85	1174	0.95	1232	1.05	1287	1.15	–	–
1350	1133	0.92	1194	1.03	1252	1.14	–	–	–	–
1425	1154	1.01	1215	1.12	–	–	–	–	–	–
1500	1175	1.09	–	–	–	–	–	–	–	–

NOTE: For more information, see General Fan Performance Notes.

Boldface indicates field supplied drive is required.

1. Recommend using field supplied fan pulley (part no. KR11AG006) and belt (part no. KR30AE039).
2. Recommend using field supplied motor pulley (part no. KR11HY161) and belt (part no. KR30AE035).

FAN PERFORMANCE (cont.)

Table 37 – 48TC**04

3 PHASE

3 TON HORIZONTAL SUPPLY

CFM	AVAILABLE EXTERNAL STATIC PRESSURE (in. wg)									
	0.2		0.4		0.6		0.8		1.0	
	RPM	BHP	RPM	BHP	RPM	BHP	RPM	BHP	RPM	BHP
	Field Supplied Drive ¹		Standard Static Option				Medium Static Option			
900	553	0.14	681	0.22	782	0.32	870	0.42	948	0.53
975	575	0.16	700	0.25	801	0.35	888	0.46	965	0.57
1050	597	0.18	720	0.28	820	0.38	906	0.49	983	0.61
1125	620	0.21	741	0.31	839	0.42	925	0.54	1001	0.66
1200	643	0.23	762	0.34	859	0.46	944	0.58	1020	0.71
1275	667	0.27	783	0.38	879	0.50	963	0.63	1038	0.76
1350	691	0.30	805	0.42	900	0.55	983	0.68	1057	0.82
1425	715	0.34	827	0.47	920	0.60	1002	0.74	1076	0.88
1500	740	0.38	849	0.52	941	0.66	1023	0.80	1096	0.95

CFM	AVAILABLE EXTERNAL STATIC PRESSURE (in. wg)									
	1.2		1.4		1.6		1.8		2.0	
	RPM	BHP	RPM	BHP	RPM	BHP	RPM	BHP	RPM	BHP
	Medium Static Option					High Static Option				
900	1019	0.64	1084	0.76	1146	0.89	1203	1.02	1258	1.16
975	1036	0.69	1101	0.81	1162	0.94	1219	1.08	1274	1.22
1050	1053	0.74	1118	0.86	1179	1.00	1236	1.14	1290	1.28
1125	1071	0.79	1135	0.92	1196	1.06	1253	1.20	1307	1.35
1200	1089	0.84	1153	0.98	1213	1.12	1270	1.27	1324	1.42
1275	1107	0.90	1171	1.04	1231	1.19	1287	1.34	1341	1.50
1350	1126	0.96	1189	1.11	1249	1.26	1305	1.42	1358	1.58
1425	1144	1.03	1208	1.18	1267	1.34	1323	1.50	1376	1.66
1500	1163	1.10	1226	1.25	1285	1.41	1341	1.58	1394	1.75

NOTE: For more information, see General Fan Performance Notes.

1. Recommend using field supplied drive (part no. KR11AG006) and belt (part no. KR30AE039)

Table 38 – 48TC**04

3 PHASE

3 TON VERTICAL SUPPLY

CFM	AVAILABLE EXTERNAL STATIC PRESSURE (in. wg)									
	0.2		0.4		0.6		0.8		1.0	
	RPM	BHP	RPM	BHP	RPM	BHP	RPM	BHP	RPM	BHP
	Field Supplied Drive ¹		Standard Static Option				Medium Static Option			
900	567	0.15	688	0.22	786	0.30	871	0.37	947	0.44
975	591	0.17	710	0.26	807	0.34	891	0.42	966	0.49
1050	615	0.20	732	0.29	828	0.38	911	0.47	985	0.55
1125	641	0.23	755	0.33	849	0.42	931	0.52	1005	0.61
1200	666	0.26	778	0.37	871	0.47	952	0.57	1025	0.67
1275	693	0.29	802	0.41	893	0.53	974	0.63	1046	0.74
1350	719	0.33	826	0.46	916	0.58	995	0.70	1067	0.81
1425	746	0.38	850	0.51	939	0.64	1017	0.76	1088	0.89
1500	773	0.42	875	0.57	963	0.70	1040	0.84	1110	0.96

CFM	AVAILABLE EXTERNAL STATIC PRESSURE (in. wg)									
	1.2		1.4		1.6		1.8		2.0	
	RPM	BHP	RPM	BHP	RPM	BHP	RPM	BHP	RPM	BHP
	Medium Static Option					High Static Option				
900	1016	0.51	1080	0.57	1139	0.64	1195	0.71	1249	0.77
975	1034	0.57	1098	0.64	1157	0.72	1213	0.79	1266	0.86
1050	1053	0.63	1116	0.71	1176	0.79	1231	0.87	1284	0.95
1125	1073	0.70	1135	0.79	1194	0.87	1250	0.96	1302	1.04
1200	1093	0.77	1155	0.87	1213	0.96	1268	1.05	1321	1.14
1275	1113	0.85	1174	0.95	1232	1.05	1287	1.15	1339	1.25
1350	1133	0.92	1194	1.03	1252	1.14	1307	1.25	1358	1.35
1425	1154	1.01	1215	1.12	1272	1.24	1326	1.35	1378	1.46
1500	1175	1.09	1235	1.22	1292	1.34	1346	1.46	1397	1.58

NOTE: For more information, see General Fan Performance Notes.

Boldface indicates field supplied drive is required.

1. Recommend using field supplied fan pulley (part no. KR11AG006) and belt (part no. KR30AE039).

FAN PERFORMANCE (cont.)

Table 39 – 48TC05**

1 PHASE

4 TON HORIZONTAL SUPPLY

CFM	AVAILABLE EXTERNAL STATIC PRESSURE (in. wg)									
	0.2		0.4		0.6		0.8		1.0	
	RPM	BHP	RPM	BHP	RPM	BHP	RPM	BHP	RPM	BHP
	Standard Static Option					Medium Static Option				
1200	643	0.23	762	0.34	859	0.46	944	0.58	1020	0.71
1300	675	0.28	790	0.40	886	0.52	969	0.65	1044	0.78
1400	707	0.33	819	0.45	913	0.58	996	0.72	1070	0.86
1500	740	0.38	849	0.52	941	0.66	1023	0.80	1096	0.95
1600	773	0.45	879	0.59	970	0.73	1050	0.88	1123	1.04
1700	807	0.52	910	0.67	999	0.82	1078	0.98	1150	1.14
1800	841	0.59	942	0.75	1029	0.91	1106	1.08	1177	1.25
1900	875	0.68	974	0.85	1059	1.02	1135	1.19	1205	1.37
2000	910	0.77	1006	0.95	1090	1.13	1165	1.31	1234	1.49

CFM	AVAILABLE EXTERNAL STATIC PRESSURE (in. wg)									
	1.2		1.4		1.6		1.8		2.0	
	RPM	BHP	RPM	BHP	RPM	BHP	RPM	BHP	RPM	BHP
	Medium Static Option					Field Supplied Drive ¹				
1200	1089	0.84	1153	0.98	1213	1.12	-	-	-	-
1300	1113	0.92	1177	1.06	-	-	-	-	-	-
1400	1138	1.01	1201	1.15	-	-	-	-	-	-
1500	1163	1.10	-	-	-	-	-	-	-	-
1600	1189	1.20	-	-	-	-	-	-	-	-
1700	-	-	-	-	-	-	-	-	-	-
1800	-	-	-	-	-	-	-	-	-	-
1900	-	-	-	-	-	-	-	-	-	-
2000	-	-	-	-	-	-	-	-	-	-

NOTE: For more information, see General Fan Performance Notes.

Boldface indicates field supplied drive is required.

1. Recommend using field supplied motor pulley (part no. KR11HY161) and belt (part no. KR30AE035).

Table 40 – 48TC05**

1 PHASE

4 TON VERTICAL SUPPLY

CFM	AVAILABLE EXTERNAL STATIC PRESSURE (in. wg)									
	0.2		0.4		0.6		0.8		1.0	
	RPM	BHP	RPM	BHP	RPM	BHP	RPM	BHP	RPM	BHP
	Standard Static Option					Medium Static Option				
1200	666	0.26	778	0.37	871	0.47	952	0.57	1025	0.67
1300	701	0.31	810	0.43	901	0.54	981	0.65	1053	0.76
1400	737	0.36	842	0.49	931	0.62	1010	0.74	1081	0.86
1500	773	0.42	875	0.57	963	0.70	1040	0.84	1110	0.96
1600	810	0.49	909	0.65	994	0.79	1070	0.94	1140	1.08
1700	847	0.57	943	0.73	1027	0.89	1101	1.05	1170	1.20
1800	885	0.66	978	0.83	1060	1.00	1133	1.16	1200	1.32
1900	923	0.75	1014	0.94	1093	1.11	1165	1.29	1231	1.46
2000	962	0.85	1049	1.05	1127	1.24	1198	1.42	1263	1.61

CFM	AVAILABLE EXTERNAL STATIC PRESSURE (in. wg)									
	1.2		1.4		1.6		1.8		2.0	
	RPM	BHP	RPM	BHP	RPM	BHP	RPM	BHP	RPM	BHP
	Medium Static Option					Field Supplied Drive ¹				
1200	1093	0.77	1155	0.87	1213	0.96	1268	1.05	1321	1.14
1300	1119	0.87	1181	0.98	1239	1.08	1294	1.18	-	-
1400	1147	0.98	1208	1.09	-	-	-	-	-	-
1500	1175	1.09	-	-	-	-	-	-	-	-
1600	-	-	-	-	-	-	-	-	-	-
1700	-	-	-	-	-	-	-	-	-	-
1800	-	-	-	-	-	-	-	-	-	-
1900	-	-	-	-	-	-	-	-	-	-
2000	-	-	-	-	-	-	-	-	-	-

NOTE: For more information, see General Fan Performance Notes.

Boldface indicates field supplied drive is required.

1. Recommend using field supplied motor pulley (part no. KR11HY161) and belt (part no. KR30AE035).

FAN PERFORMANCE (cont.)

Table 41 – 48TC05**

3 PHASE

4 TON HORIZONTAL SUPPLY

CFM	AVAILABLE EXTERNAL STATIC PRESSURE (in. wg)									
	0.2		0.4		0.6		0.8		1.0	
	RPM	BHP	RPM	BHP	RPM	BHP	RPM	BHP	RPM	BHP
	Standard Static Option				Medium Static Option					
1200	643	0.23	762	0.34	859	0.46	944	0.58	1020	0.71
1300	675	0.28	790	0.40	886	0.52	969	0.65	1044	0.78
1400	707	0.33	819	0.45	913	0.58	996	0.72	1070	0.86
1500	740	0.38	849	0.52	941	0.66	1023	0.80	1096	0.95
1600	773	0.45	879	0.59	970	0.73	1050	0.88	1123	1.04
1700	807	0.52	910	0.67	999	0.82	1078	0.98	1150	1.14
1800	841	0.59	942	0.75	1029	0.91	1106	1.08	1177	1.25
1900	875	0.68	974	0.85	1059	1.02	1135	1.19	1205	1.37
2000	910	0.77	1006	0.95	1090	1.13	1165	1.31	1234	1.49

CFM	AVAILABLE EXTERNAL STATIC PRESSURE (in. wg)									
	1.2		1.4		1.6		1.8		2.0	
	RPM	BHP	RPM	BHP	RPM	BHP	RPM	BHP	RPM	BHP
	Medium Static Option				High Static Option					
1200	1089	0.84	1153	0.98	1213	1.12	1270	1.27	1324	1.42
1300	1113	0.92	1177	1.06	1237	1.21	1293	1.36	1347	1.52
1400	1138	1.01	1201	1.15	1261	1.31	1317	1.47	1370	1.63
1500	1163	1.10	1226	1.25	1285	1.41	1341	1.58	1394	1.75
1600	1189	1.20	1252	1.36	1310	1.53	1365	1.70	1418	1.87
1700	1216	1.31	1277	1.48	1335	1.65	1390	1.83	1442	2.01
1800	1242	1.42	1303	1.60	1361	1.78	1415	1.96	1467	2.15
1900	1270	1.55	1330	1.73	1387	1.92	1441	2.11	1493	2.30
2000	1297	1.68	1357	1.87	1414	2.07	1467	2.26	-	-

NOTE: For more information, see General Fan Performance Notes.

Boldface indicates field supplied drive is required.

1. Recommend using field supplied fan pulley (part no. KR11AZ506), motor pulley (part no. KR11HY181) and belt (part no. KR30AE041).

Table 42 – 48TC05**

3 PHASE

4 TON VERTICAL SUPPLY

CFM	AVAILABLE EXTERNAL STATIC PRESSURE (in. wg)									
	0.2		0.4		0.6		0.8		1.0	
	RPM	BHP	RPM	BHP	RPM	BHP	RPM	BHP	RPM	BHP
	Standard Static Option				Medium Static Option					
1200	666	0.26	778	0.37	871	0.47	952	0.57	1025	0.67
1300	701	0.31	810	0.43	901	0.54	981	0.65	1053	0.76
1400	737	0.36	842	0.49	931	0.62	1010	0.74	1081	0.86
1500	773	0.42	875	0.57	963	0.70	1040	0.84	1110	0.96
1600	810	0.49	909	0.65	994	0.79	1070	0.94	1140	1.08
1700	847	0.57	943	0.73	1027	0.89	1101	1.05	1170	1.20
1800	885	0.66	978	0.83	1060	1.00	1133	1.16	1200	1.32
1900	923	0.75	1014	0.94	1093	1.11	1165	1.29	1231	1.46
2000	962	0.85	1049	1.05	1127	1.24	1198	1.42	1263	1.61

CFM	AVAILABLE EXTERNAL STATIC PRESSURE (in. wg)									
	1.2		1.4		1.6		1.8		2.0	
	RPM	BHP	RPM	BHP	RPM	BHP	RPM	BHP	RPM	BHP
	Medium Static Option				High Static Option					
1200	1093	0.77	1155	0.87	1213	0.96	1268	1.05	1321	1.14
1300	1119	0.87	1181	0.98	1239	1.08	1294	1.18	1346	1.28
1400	1147	0.98	1208	1.09	1265	1.21	1320	1.32	1371	1.43
1500	1175	1.09	1235	1.22	1292	1.34	1346	1.46	1397	1.58
1600	1204	1.21	1263	1.35	1320	1.48	1373	1.61	1424	1.74
1700	1233	1.34	1292	1.49	1348	1.63	1401	1.77	1451	1.91
1800	1262	1.48	1321	1.64	1376	1.79	1428	1.94	1479	2.09
1900	1293	1.63	1350	1.79	1405	1.96	1457	2.12	1506	2.28
2000	1323	1.79	1380	1.96	1434	2.13	1486	2.31	-	-

NOTE: For more information, see General Fan Performance Notes.

Boldface indicates field supplied drive is required.

1. Recommend using field supplied fan pulley (part no. KR11AZ506), motor pulley (part no. KR11HY181) and belt (part no. KR30AE041).

FAN PERFORMANCE (cont.)

Table 43 – 48TC**06

1 PHASE

5 TON HORIZONTAL SUPPLY

CFM	AVAILABLE EXTERNAL STATIC PRESSURE (in. wg)									
	0.2		0.4		0.6		0.8		1.0	
	RPM	BHP	RPM	BHP	RPM	BHP	RPM	BHP	RPM	BHP
	Standard Static Option									
1500	800	0.39	904	0.49	999	0.60	1087	0.72	1169	0.85
1625	849	0.48	947	0.59	1038	0.70	1122	0.83	1201	0.96
1750	899	0.59	992	0.70	1078	0.82	1159	0.95	1235	1.08
1875	950	0.70	1038	0.82	1120	0.95	1198	1.08	1271	1.22
2000	1001	0.84	1085	0.96	1163	1.09	1238	1.23	1309	1.38
2125	1053	0.99	1133	1.12	1208	1.26	1280	1.40	-	-
2250	1106	1.16	1182	1.29	1254	1.44	-	-	-	-
2375	1159	1.34	1231	1.49	-	-	-	-	-	-
2500	-	-	-	-	-	-	-	-	-	-

CFM	AVAILABLE EXTERNAL STATIC PRESSURE (in. wg)									
	1.2		1.4		1.6		1.8		2.0	
	RPM	BHP	RPM	BHP	RPM	BHP	RPM	BHP	RPM	BHP
	Medium Static Option									
1500	1247	0.98	1320	1.13	1390	1.28	1457	1.44	-	-
1625	1276	1.10	1348	1.24	1416	1.40	-	-	-	-
1750	1308	1.22	1377	1.38	-	-	-	-	-	-
1875	1342	1.37	-	-	-	-	-	-	-	-
2000	-	-	-	-	-	-	-	-	-	-
2125	-	-	-	-	-	-	-	-	-	-
2250	-	-	-	-	-	-	-	-	-	-
2375	-	-	-	-	-	-	-	-	-	-
2500	-	-	-	-	-	-	-	-	-	-

NOTE: For more information, see General Fan Performance Notes.

Table 44 – 48TC**06

1 PHASE

5 TON VERTICAL SUPPLY

CFM	AVAILABLE EXTERNAL STATIC PRESSURE (in. wg)									
	0.2		0.4		0.6		0.8		1.0	
	RPM	BHP	RPM	BHP	RPM	BHP	RPM	BHP	RPM	BHP
	Standard Static Option								Medium Static Option	
1500	848	0.42	968	0.55	1069	0.68	1158	0.80	1238	0.94
1625	897	0.51	1013	0.65	1111	0.79	1198	0.93	1277	1.07
1750	947	0.61	1059	0.76	1155	0.91	1240	1.06	1318	1.21
1875	997	0.72	1105	0.89	1199	1.05	1283	1.21	1359	1.37
2000	1048	0.85	1153	1.03	1244	1.20	1326	1.37	-	-
2125	1100	1.00	1201	1.19	1290	1.37	-	-	-	-
2250	1152	1.16	1250	1.36	-	-	-	-	-	-
2375	1205	1.34	-	-	-	-	-	-	-	-
2500	-	-	-	-	-	-	-	-	-	-

CFM	AVAILABLE EXTERNAL STATIC PRESSURE (in. wg)									
	1.2		1.4		1.6		1.8		2.0	
	RPM	BHP	RPM	BHP	RPM	BHP	RPM	BHP	RPM	BHP
	Medium Static Option						Field-Supplied Drive ¹			
1500	1312	1.07	1380	1.20	1445	1.34	1506	1.48	-	-
1625	1350	1.21	1418	1.35	1482	1.50	-	-	-	-
1750	1390	1.36	-	-	-	-	-	-	-	-
1875	-	-	-	-	-	-	-	-	-	-
2000	-	-	-	-	-	-	-	-	-	-
2125	-	-	-	-	-	-	-	-	-	-
2250	-	-	-	-	-	-	-	-	-	-
2375	-	-	-	-	-	-	-	-	-	-
2500	-	-	-	-	-	-	-	-	-	-

NOTE: For more information, see General Fan Performance Notes.

Boldface indicates field supplied drive is required.

1. Recommend using field supplied motor pulley (part no. KR11HY171) and belt (part no. KR30AE039).

FAN PERFORMANCE (cont.)

Table 45 – 48TC06**

3 PHASE

5 TON HORIZONTAL SUPPLY

CFM	AVAILABLE EXTERNAL STATIC PRESSURE (in. wg)									
	0.2		0.4		0.6		0.8		1.0	
	RPM	BHP	RPM	BHP	RPM	BHP	RPM	BHP	RPM	BHP
	Standard Static Option									
1500	800	0.39	904	0.49	999	0.60	1087	0.72	1169	0.85
1625	849	0.48	947	0.59	1038	0.70	1122	0.83	1201	0.96
1750	899	0.59	992	0.70	1078	0.82	1159	0.95	1235	1.08
1875	950	0.70	1038	0.82	1120	0.95	1198	1.08	1271	1.22
2000	1001	0.84	1085	0.96	1163	1.09	1238	1.23	1309	1.38
2125	1053	0.99	1133	1.12	1208	1.26	1280	1.40	1348	1.55
2250	1106	1.16	1182	1.29	1254	1.44	1323	1.59	1389	1.74
2375	1159	1.34	1231	1.49	1300	1.64	1367	1.80	1430	1.96
2500	1212	1.55	1281	1.70	1348	1.86	1412	2.02	1473	2.19

CFM	AVAILABLE EXTERNAL STATIC PRESSURE (in. wg)									
	1.2		1.4		1.6		1.8		2.0	
	RPM	BHP	RPM	BHP	RPM	BHP	RPM	BHP	RPM	BHP
	Medium Static Option					High Static Option				
1500	1247	0.98	1320	1.13	1390	1.28	1457	1.44	1522	1.61
1625	1276	1.10	1348	1.24	1416	1.40	1481	1.56	1544	1.73
1750	1308	1.22	1377	1.38	1444	1.53	1507	1.70	1569	1.87
1875	1342	1.37	1409	1.52	1473	1.69	1536	1.86	1596	2.03
2000	1377	1.53	1442	1.69	1505	1.86	1565	2.03	1624	2.21
2125	1414	1.71	1477	1.87	1538	2.04	1597	2.22	1654	2.40
2250	1452	1.91	1514	2.08	1573	2.25	1630	2.43	1686	2.62
2375	1492	2.12	1551	2.30	1609	2.48	1665	2.66	1719	2.85
2500	1533	2.36	1591	2.54	1647	2.73	-	-	-	-

NOTE: For more information, see General Fan Performance Notes.

Boldface indicates field supplied drive is required.

1. Recommend using field supplied fan pulley (part no. KR11AZ506), motor pulley (part no. KR11HY191) and belt (part no. KR30AE042).

Table 46 – 48TC06**

3 PHASE

5 TON VERTICAL SUPPLY

CFM	AVAILABLE EXTERNAL STATIC PRESSURE (in. wg)									
	0.2		0.4		0.6		0.8		1.0	
	RPM	BHP	RPM	BHP	RPM	BHP	RPM	BHP	RPM	BHP
	Standard Static Option					Medium Static Option				
1500	848	0.42	968	0.55	1069	0.68	1158	0.80	1238	0.94
1625	897	0.51	1013	0.65	1111	0.79	1198	0.93	1277	1.07
1750	947	0.61	1059	0.76	1155	0.91	1240	1.06	1318	1.21
1875	997	0.72	1105	0.89	1199	1.05	1283	1.21	1359	1.37
2000	1048	0.85	1153	1.03	1244	1.20	1326	1.37	1401	1.54
2125	1100	1.00	1201	1.19	1290	1.37	1370	1.55	1444	1.73
2250	1152	1.16	1250	1.36	1336	1.55	1415	1.75	1487	1.94
2375	1205	1.34	1299	1.55	1384	1.76	1460	1.96	1532	2.17
2500	1258	1.54	1349	1.76	1431	1.98	1506	2.20	1576	2.41

CFM	AVAILABLE EXTERNAL STATIC PRESSURE (in. wg)									
	1.2		1.4		1.6		1.8		2.0	
	RPM	BHP	RPM	BHP	RPM	BHP	RPM	BHP	RPM	BHP
	Medium Static Option					High Static Option				
1500	1312	1.07	1380	1.20	1445	1.34	1506	1.48	1564	1.62
1625	1350	1.21	1418	1.35	1482	1.50	1542	1.64	1600	1.79
1750	1390	1.36	1457	1.51	1520	1.67	1580	1.83	1637	1.98
1875	1430	1.53	1496	1.69	1559	1.86	1618	2.02	1675	2.19
2000	1471	1.72	1536	1.89	1598	2.06	1657	2.24	1713	2.41
2125	1513	1.92	1577	2.10	1638	2.28	1696	2.47	1752	2.65
2250	1555	2.13	1619	2.33	1679	2.52	1736	2.72	-	-
2375	1598	2.37	1661	2.57	1720	2.78	-	-	-	-
2500	1642	2.63	1704	2.84	-	-	-	-	-	-

NOTE: For more information, see General Fan Performance Notes.

Boldface indicates field supplied drive is required.

1. Recommend using field supplied fan pulley (part no. KR11AZ506), motor pulley (part no. KR11HY191) and belt (part no. KR30AE042).

FAN PERFORMANCE (cont.)

Table 47 – 48TC**07

3 PHASE

6 TON HORIZONTAL SUPPLY

CFM	AVAILABLE EXTERNAL STATIC PRESSURE (in. wg)									
	0.2		0.4		0.6		0.8		1.0	
	RPM	BHP	RPM	BHP	RPM	BHP	RPM	BHP	RPM	BHP
	Field Supplied Drive¹		Standard Static Option							
1800	913	0.64	1010	0.80	1098	0.98	1178	1.16	1252	1.35
1950	972	0.78	1065	0.96	1148	1.14	1226	1.34	1298	1.54
2100	1032	0.95	1120	1.14	1200	1.33	1275	1.54	1345	1.75
2250	1093	1.14	1177	1.34	1254	1.55	1325	1.76	1393	1.98
2400	1155	1.36	1234	1.57	1308	1.78	1377	2.01	1443	2.24
2550	1217	1.60	1293	1.82	1363	2.05	1430	2.28	1494	2.53
2700	1280	1.87	1352	2.10	1420	2.34	1484	2.59	1546	2.84
2850	1343	2.17	1412	2.42	1477	2.67	1539	2.93	1599	3.19
3000	1406	2.50	1472	2.76	1535	3.03	1595	3.29	1653	3.57

CFM	AVAILABLE EXTERNAL STATIC PRESSURE (in. wg)									
	1.2		1.4		1.6		1.8		2.0	
	RPM	BHP	RPM	BHP	RPM	BHP	RPM	BHP	RPM	BHP
	Standard Static Option			Medium Static Option				High Static Option		
1800	1322	1.56	1388	1.77	1451	1.98	1510	2.21	1568	2.44
1950	1366	1.75	1430	1.97	1491	2.20	1550	2.43	1606	2.67
2100	1411	1.97	1473	2.20	1533	2.43	1590	2.67	1645	2.92
2250	1457	2.21	1518	2.45	1576	2.69	1632	2.94	1686	3.20
2400	1505	2.48	1564	2.73	1621	2.98	1676	3.24	1729	3.51
2550	1554	2.78	1612	3.03	1667	3.30	1721	3.57	-	-
2700	1604	3.10	1660	3.37	1715	3.64	-	-	-	-
2850	1656	3.46	-	-	-	-	-	-	-	-
3000	-	-	-	-	-	-	-	-	-	-

NOTE: For more information, see General Fan Performance Notes.

Boldface indicates field-supplied drive is required.

1. Recommend using field-supplied fan pulley (part no. KR11AZ406), motor pulley (part no. KR11HY151) and belt (part no. KR29AF035).

Table 48 – 48TC**07

3 PHASE

6 TON VERTICAL SUPPLY

CFM	AVAILABLE EXTERNAL STATIC PRESSURE (in. wg)									
	0.2		0.4		0.6		0.8		1.0	
	RPM	BHP	RPM	BHP	RPM	BHP	RPM	BHP	RPM	BHP
	Field-Supplied Drive¹		Standard Static Option							
1800	967	0.63	1075	0.80	1170	0.97	1255	1.13	1333	1.28
1950	1029	0.77	1132	0.96	1223	1.14	1306	1.32	1382	1.49
2100	1091	0.93	1189	1.14	1278	1.33	1358	1.52	1433	1.71
2250	1154	1.11	1248	1.33	1333	1.55	1411	1.75	1484	1.96
2400	1218	1.32	1308	1.55	1390	1.78	1466	2.01	1537	2.23
2550	1283	1.55	1369	1.80	1448	2.05	1521	2.29	1590	2.52
2700	1348	1.80	1431	2.07	1507	2.33	1578	2.59	1645	2.84
2850	1414	2.09	1493	2.37	1566	2.65	1636	2.92	1701	3.19
3000	1479	2.40	1556	2.70	1627	3.00	1694	3.29	1757	3.57

CFM	AVAILABLE EXTERNAL STATIC PRESSURE (in. wg)									
	1.2		1.4		1.6		1.8		2.0	
	RPM	BHP	RPM	BHP	RPM	BHP	RPM	BHP	RPM	BHP
	Medium Static Option				High Static Option					
1800	1406	1.43	1475	1.58	1540	1.72	1601	1.87	1660	2.00
1950	1454	1.65	1521	1.82	1585	1.98	1645	2.13	1703	2.29
2100	1502	1.89	1568	2.07	1631	2.25	1690	2.42	1747	2.59
2250	1552	2.15	1617	2.35	1678	2.54	1737	2.73	1793	2.92 ²
2400	1603	2.44	1666	2.65	1727	2.86	1784	3.06	1839	3.26
2550	1655	2.75	1717	2.98	1776	3.20	1833	3.42	1887	3.64
2700	1709	3.09	1769	3.33	1827	3.57	-	-	-	-
2850	1763	3.45	-	-	-	-	-	-	-	-
3000	-	-	-	-	-	-	-	-	-	-

NOTE: For more information, see General Fan Performance Notes.

Boldface indicates field supplied drive is required.

1. Recommend using field supplied fan pulley (part no. KR11AZ406), motor pulley (part no. KR11HY151) and belt (part no. KR29AF035).
2. Recommend using field supplied fan pulley (part no. KR11AZ506), motor pulley (part no. KR11HY191) and belt (part no. KR29AF042).

FAN PERFORMANCE (cont.)

Table 49 – 48TC08**

3 PHASE

7.5 TON HORIZONTAL SUPPLY

CFM	AVAILABLE EXTERNAL STATIC PRESSURE (in. wg)									
	0.2		0.4		0.6		0.8		1.0	
	RPM	BHP	RPM	BHP	RPM	BHP	RPM	BHP	RPM	BHP
	Standard Static Option								Medium Static Option	
2250	505	0.52	586	0.73	657	0.97	722	1.22	782	1.50
2438	533	0.62	610	0.85	679	1.09	742	1.36	800	1.65
2625	562	0.74	635	0.98	701	1.23	762	1.51	819	1.81
2813	591	0.88	661	1.13	725	1.39	783	1.68	839	1.98
3000	621	1.03	688	1.29	749	1.57	806	1.87	859	2.18
3188	652	1.21	715	1.48	774	1.77	829	2.07	881	2.40
3375	682	1.40	743	1.68	800	1.98	853	2.30	903	2.63
3563	713	1.61	772	1.91	826	2.22	878	2.55	927	2.89
3750	745	1.85	801	2.15	853	2.48	903	2.82	951	3.18

CFM	AVAILABLE EXTERNAL STATIC PRESSURE (in. wg)									
	1.2		1.4		1.6		1.8		2.0	
	RPM	BHP	RPM	BHP	RPM	BHP	RPM	BHP	RPM	BHP
	Medium Static Option					High Static Option				
2250	838	1.81	891	2.12	941	2.46	988	2.82	1033	3.19
2438	854	1.96	906	2.28	955	2.63	1001	2.99	1046	3.37
2625	872	2.12	922	2.46	970	2.81	1016	3.17	1060	3.56
2813	890	2.31	940	2.65	986	3.01	1031	3.38	1074	3.77
3000	910	2.51	958	2.86	1004	3.23	1048	3.61	1090	4.01
3188	930	2.74	977	3.10	1022	3.47	1065	3.86	1107	4.26¹
3375	951	2.99	997	3.35	1041	3.74	1083	4.13	1124	4.54
3563	973	3.26	1018	3.63	1061	4.02	1103	4.43	-	-
3750	996	3.55	1040	3.93	1082	4.34	-	-	-	-

NOTE: For more information, see General Fan Performance Notes.

Boldface indicates field supplied drive is required.

1. Recommend using field supplied fan pulley (part no. KR11AZ002) and belt (part no. KR29AF054).

Table 50 – 48TC08**

3 PHASE

7.5 TON VERTICAL SUPPLY

CFM	AVAILABLE EXTERNAL STATIC PRESSURE (in. wg)									
	0.2		0.4		0.6		0.8		1.0	
	RPM	BHP	RPM	BHP	RPM	BHP	RPM	BHP	RPM	BHP
	Standard Static Option								Medium Static Option	
2250	513	0.54	595	0.76	665	1.01	728	1.27	786	1.56
2438	541	0.65	620	0.89	688	1.14	750	1.42	806	1.71
2625	570	0.77	645	1.02	712	1.29	772	1.58	827	1.88
2813	600	0.91	672	1.18	736	1.46	794	1.76	848	2.07
3000	629	1.07	699	1.35	761	1.64	818	1.95	871	2.28
3188	660	1.25	726	1.54	787	1.85	842	2.17	894	2.51
3375	690	1.45	754	1.75	813	2.07	867	2.41	917	2.76
3563	721	1.67	783	1.98	840	2.32	892	2.67	941	3.03
3750	752	1.91	812	2.24	867	2.59	918	2.95	966	3.32

CFM	AVAILABLE EXTERNAL STATIC PRESSURE (in. wg)									
	1.2		1.4		1.6		1.8		2.0	
	RPM	BHP	RPM	BHP	RPM	BHP	RPM	BHP	RPM	BHP
	Medium Static Option					High Static Option				
2250	839	1.86	889	2.18	935	2.52	980	2.87	1022	3.23
2438	858	2.02	907	2.35	953	2.70	997	3.06	1039	3.43
2625	878	2.20	926	2.54	972	2.89	1015	3.26	1056	3.64
2813	899	2.40	946	2.75	991	3.11	1033	3.49	1074	3.88
3000	920	2.62	966	2.98	1010	3.35	1052	3.74	1093	4.14
3188	942	2.86	987	3.23	1031	3.61	1072	4.01	1112	4.42¹
3375	964	3.12	1009	3.50	1052	3.89	1093	4.30	-	-
3563	988	3.41	1032	3.80	1074	4.20	1114	4.61	-	-
3750	1011	3.71	1054	4.11	1096	4.53	-	-	-	-

NOTE: For more information, see General Fan Performance Notes.

Boldface indicates field-supplied drive is required.

1. Recommend using field-supplied fan pulley (part no. KR11AZ002) and belt (part no. KR29AF054).

FAN PERFORMANCE (cont.)

Table 51 – 48TC09**

3 PHASE

8.5 TON HORIZONTAL SUPPLY

CFM	AVAILABLE EXTERNAL STATIC PRESSURE (in. wg)									
	0.2		0.4		0.6		0.8		1.0	
	RPM	BHP	RPM	BHP	RPM	BHP	RPM	BHP	RPM	BHP
	Field – Supplied Drive ¹		Standard Static Option						Medium Static Option	
2550	497	0.48	579	0.61	651	0.75	717	0.90	777	1.05
2763	524	0.58	602	0.72	671	0.87	735	1.03	794	1.19
2975	551	0.70	626	0.86	693	1.01	754	1.18	812	1.35
3188	580	0.84	651	1.00	716	1.17	775	1.34	831	1.52
3400	609	1.00	677	1.17	739	1.35	797	1.53	851	1.71
3613	638	1.17	703	1.35	763	1.54	819	1.73	871	1.93
3825	668	1.37	730	1.56	788	1.76	842	1.96	893	2.16
4038	698	1.59	758	1.79	813	2.00	866	2.20	915	2.42
4250	728	1.83	786	2.04	839	2.26	890	2.47	938	2.70

CFM	AVAILABLE EXTERNAL STATIC PRESSURE (in. wg)									
	1.2		1.4		1.6		1.8		2.0	
	RPM	BHP	RPM	BHP	RPM	BHP	RPM	BHP	RPM	BHP
	Medium Static Option					High Static Option				
2550	833	1.21	886	1.38	936	1.56	984	1.74	1029	1.93
2763	849	1.36	900	1.53	950	1.72	996	1.90	1041	2.10
2975	865	1.52	916	1.70	964	1.89	1010	2.09	1054	2.29
3188	883	1.70	933	1.89	980	2.09	1025	2.29	1068	2.50
3400	902	1.90	950	2.10	996	2.30	1041	2.51	1083	2.73
3613	921	2.13	969	2.33	1014	2.54	1057	2.76	1099	2.98²
3825	941	2.37	988	2.58	1032	2.80	1075	3.02	1116	3.25
4038	963	2.63	1008	2.86	1051	3.08	1093	3.31	1133	3.55
4250	984	2.92	1029	3.15	1071	3.39	1112	3.63	1152	3.87

NOTE: For more information, see General Fan Performance Notes.

Boldface indicates field – supplied drive is required.

1. Recommend using field – supplied fan pulley (part no. KR11AK012) and belt (part no. KR29AF055).
2. Recommend using field – supplied motor pulley (part no. KR11HY310), fan pulley (part no. KR11AZ002) and belt (part no. KR29AF054).

Table 52 – 48TC09**

3 PHASE

8.5 TON VERTICAL SUPPLY

CFM	AVAILABLE EXTERNAL STATIC PRESSURE (in. wg)									
	0.2		0.4		0.6		0.8		1.0	
	RPM	BHP	RPM	BHP	RPM	BHP	RPM	BHP	RPM	BHP
	Standard Static Option						Medium Static Option			
2550	526	0.51	600	0.65	666	0.79	727	0.93	783	1.07
2763	557	0.62	627	0.77	690	0.92	749	1.08	804	1.23
2975	588	0.75	655	0.91	716	1.08	772	1.24	825	1.40
3188	621	0.90	684	1.07	743	1.25	797	1.42	848	1.60
3400	653	1.06	714	1.25	770	1.44	822	1.62	872	1.81
3613	687	1.25	744	1.45	798	1.65	849	1.84	897	2.04
3825	720	1.45	775	1.67	827	1.88	876	2.09	922	2.30
4038	754	1.69	807	1.91	856	2.13	904	2.35	949	2.57
4250	788	1.94	839	2.17	886	2.41	932	2.64	976	2.88

CFM	AVAILABLE EXTERNAL STATIC PRESSURE (in. wg)									
	1.2		1.4		1.6		1.8		2.0	
	RPM	BHP	RPM	BHP	RPM	BHP	RPM	BHP	RPM	BHP
	Medium Static Option					High Static Option				
2550	836	1.20	886	1.34	934	1.48	979	1.61	1022	1.74
2763	855	1.37	904	1.52	950	1.67	995	1.82	1037	1.97
2975	875	1.56	923	1.72	968	1.88	1012	2.04	1053	2.20
3188	897	1.77	943	1.94	987	2.11	1030	2.29	1071	2.46
3400	919	1.99	964	2.18	1007	2.36	1049	2.55	1089	2.73¹
3613	943	2.24	986	2.44	1029	2.63	1069	2.83	1108	3.02
3825	967	2.51	1010	2.71	1051	2.92	1090	3.13	1129	3.34
4038	992	2.80	1034	3.02	1074	3.24	1112	3.46	1150	3.68
4250	1018	3.11	1058	3.34	1097	3.57	–	–	–	–

NOTE: For more information, see General Fan Performance Notes.

Boldface indicates field supplied drive is required.

1. Recommend using field supplied motor pulley (part no. KR11HY310), fan pulley (part no. KR11AZ002) and belt (part no. KR29AF054).

FAN PERFORMANCE (cont.)

Table 53 – 48TC12**

3 PHASE

10 TON HORIZONTAL SUPPLY

CFM	AVAILABLE EXTERNAL STATIC PRESSURE (in. wg)									
	0.2		0.4		0.6		0.8		1.0	
	RPM	BHP	RPM	BHP	RPM	BHP	RPM	BHP	RPM	BHP
	Field Supplied Drive¹		Standard Static Option						Medium Static Option	
3000	579	0.70	660	0.89	732	1.09	799	1.29	860	1.50
3250	613	0.85	690	1.06	760	1.27	823	1.49	883	1.71
3500	648	1.03	721	1.25	788	1.48	850	1.71	907	1.95
3750	683	1.23	753	1.47	817	1.71	877	1.96	933	2.21
4000	719	1.45	786	1.71	848	1.97	905	2.23	959	2.50
4250	756	1.71	819	1.98	879	2.26	934	2.53	987	2.81
4500	792	1.99	853	2.28	910	2.57	964	2.87	1015	3.16
4750	830	2.31	888	2.62	943	2.92	995	3.23	1044	3.54
5000	867	2.66	923	2.98	976	3.30	1026	3.63	1074	3.95

CFM	AVAILABLE EXTERNAL STATIC PRESSURE (in. wg)									
	1.2		1.4		1.6		1.8		2.0	
	RPM	BHP	RPM	BHP	RPM	BHP	RPM	BHP	RPM	BHP
	Medium Static Option						High Static Option			
3000	917	1.70	970	1.91	1021	2.13	1070	2.34	1117	2.56
3250	938	1.93	991	2.16	1041	2.38	1089	2.61	1134	2.85
3500	961	2.18	1013	2.42	1062	2.66	1108	2.91	1153	3.15
3750	985	2.46	1035	2.71	1083	2.97	1129	3.23	1173	3.49
4000	1011	2.76	1059	3.03	1106	3.30	1151	3.58	1194	3.85
4250	1037	3.09	1084	3.38	1130	3.66	1174	3.95	1216	4.24
4500	1064	3.46	1110	3.76	1155	4.06	1198	4.36	1239	4.66
4750	1091	3.85	1137	4.16	1180	4.48	–	–	–	–
5000	1120	4.28	1164	4.61	–	–	–	–	–	–

NOTE: For more information, see General Fan Performance Notes.

Boldface indicates field supplied drive is required.

1. Recommend using field supplied fan pulley (part no. KR11AD912) and belt (part no. KR29AF051).

Table 54 – 48TC12**

3 PHASE

10 TON VERTICAL SUPPLY

CFM	AVAILABLE EXTERNAL STATIC PRESSURE (in. wg)									
	0.2		0.4		0.6		0.8		1.0	
	RPM	BHP	RPM	BHP	RPM	BHP	RPM	BHP	RPM	BHP
	Standard Static Option						Medium Static Option			
3000	616	0.79	689	0.97	757	1.16	821	1.36	882	1.57
3250	655	0.96	724	1.16	788	1.37	849	1.58	907	1.80
3500	695	1.17	760	1.38	821	1.60	879	1.83	934	2.06
3750	736	1.41	797	1.63	855	1.86	910	2.10	963	2.35
4000	777	1.68	834	1.91	889	2.16	942	2.41	993	2.67
4250	818	1.98	873	2.23	925	2.49	976	2.75	1025	3.02
4500	860	2.32	912	2.58	962	2.85	1010	3.13	1057	3.41
4750	902	2.69	951	2.97	999	3.26	1046	3.55	1091	3.84
5000	944	3.11	991	3.40	1037	3.70	1082	4.00	1125	4.31

CFM	AVAILABLE EXTERNAL STATIC PRESSURE (in. wg)									
	1.2		1.4		1.6		1.8		2.0	
	RPM	BHP	RPM	BHP	RPM	BHP	RPM	BHP	RPM	BHP
	Medium Static Option						High Static Option			
3000	939	1.79	994	2.01	1047	2.24	1098	2.47	1147	2.71
3250	962	2.03	1015	2.26	1066	2.50	1115	2.75	1163	3.00
3500	987	2.30	1038	2.54	1088	2.80	1135	3.05	1181	3.32
3750	1014	2.60	1063	2.86	1111	3.12	1157	3.39	1202	3.66
4000	1042	2.93	1090	3.20	1136	3.48	1180	3.76	1224	4.04
4250	1072	3.30	1118	3.58	1162	3.87	1205	4.16	–	–
4500	1103	3.70	1147	4.00	1190	4.29	1232	4.60	–	–
4750	1135	4.14	1177	4.45	–	–	–	–	–	–
5000	1167	4.63	–	–	–	–	–	–	–	–

NOTE: For more information, see General Fan Performance Notes.

Boldface indicates field supplied drive is required.

FAN PERFORMANCE (cont.)

Table 55 – 48TC**14

3 PHASE

12.5 TON HORIZONTAL SUPPLY

CFM	AVAILABLE EXTERNAL STATIC PRESSURE (in. wg)									
	0.2		0.4		0.6		0.8		1.0	
	RPM	BHP	RPM	BHP	RPM	BHP	RPM	BHP	RPM	BHP
	Standard Static Option								Medium Static Option	
3438	639	0.98	713	1.20	781	1.43	843	1.65	901	1.88
3750	683	1.23	753	1.47	817	1.71	877	1.96	933	2.21
4063	728	1.52	794	1.78	855	2.04	912	2.31	966	2.57
4375	774	1.85	836	2.13	894	2.41	949	2.70	1001	2.98
4688	820	2.23	879	2.53	935	2.83	987	3.14	1037	3.44
5000	867	2.66	923	2.98	976	3.30	1026	3.63	1074	3.95
5313	914	3.15	967	3.49	1018	3.83	1066	4.17	1112	4.52
5625	962	3.69	1012	4.05	1061	4.42	-	-	-	-
5938	1009	4.30	1058	4.68	-	-	-	-	-	-
6250	-	-	-	-	-	-	-	-	-	-

CFM	AVAILABLE EXTERNAL STATIC PRESSURE (in. wg)									
	1.2		1.4		1.6		1.8		2.0	
	RPM	BHP	RPM	BHP	RPM	BHP	RPM	BHP	RPM	BHP
	Medium Static Option					High Static Option				
3438	955	2.12	1007	2.35	1056	2.59	1103	2.83	1148	3.08
3750	985	2.46	1035	2.71	1083	2.97	1129	3.23	1173	3.49
4063	1017	2.84	1066	3.12	1112	3.39	1157	3.67	1200	3.95
4375	1050	3.27	1097	3.56	1142	3.86	1186	4.15	1228	4.45
4688	1084	3.75	1130	4.06	1174	4.37	1216	4.68	1257	5.00
5000	1120	4.28	1164	4.61	-	-	1248	5.27	1288	5.60
5313	-	-	-	-	-	-	-	-	-	-
5625	-	-	-	-	-	-	-	-	-	-
5938	-	-	-	-	-	-	-	-	-	-
6250	-	-	-	-	-	-	-	-	-	-

NOTE: For more information, see General Fan Performance Notes.

Boldface indicates field supplied drive is required.

Table 56 – 48TC**14

3 PHASE

12.5 TON VERTICAL SUPPLY

CFM	AVAILABLE EXTERNAL STATIC PRESSURE (in. wg)									
	0.2		0.4		0.6		0.8		1.0	
	RPM	BHP	RPM	BHP	RPM	BHP	RPM	BHP	RPM	BHP
	Standard Static Option					Medium Static Option				
3438	685	1.12	751	1.32	813	1.54	871	1.76	927	1.99
3750	736	1.41	797	1.63	855	1.86	910	2.10	963	2.35
4063	787	1.75	844	1.99	898	2.24	951	2.49	1001	2.75
4375	839	2.14	892	2.40	943	2.67	993	2.94	1041	3.21
4688	891	2.60	941	2.87	990	3.15	1037	3.44	1082	3.73
5000	944	3.11	991	3.40	1037	3.70	1082	4.00	1125	4.31
5313	997	3.69	1042	4.00	1085	4.32	1128	4.64	-	-
5625	1051	4.34	1093	4.67	-	-	-	-	-	-
5938	-	-	-	-	-	-	-	-	-	-
6250	-	-	-	-	-	-	-	-	-	-

CFM	AVAILABLE EXTERNAL STATIC PRESSURE (in. wg)									
	1.2		1.4		1.6		1.8		2.0	
	RPM	BHP	RPM	BHP	RPM	BHP	RPM	BHP	RPM	BHP
	Medium Static Option					High Static Option				
3438	981	2.23	1032	2.47	1082	2.72	1130	2.97	1177	3.23
3750	1014	2.60	1063	2.86	1111	3.12	1157	3.39	1202	3.66
4063	1049	3.02	1097	3.29	1142	3.57	1186	3.85	1230	4.14
4375	1087	3.49	1132	3.78	1176	4.08	1218	4.37	1260	4.68
4688	1126	4.03	1169	4.33	1211	4.64	-	-	-	-
5000	1167	4.63	-	-	-	-	-	-	-	-
5313	-	-	-	-	-	-	-	-	-	-
5625	-	-	-	-	-	-	-	-	-	-
5938	-	-	-	-	-	-	-	-	-	-
6250	-	-	-	-	-	-	-	-	-	-

NOTE: For more information, see General Fan Performance Notes.

Boldface indicates field supplied drive is required.

FAN PERFORMANCE (cont.)

Table 57 – 48TC16**

3 PHASE

15 TON VERTICAL SUPPLY

CFM	Available External Static Pressure (in. wg)									
	0.2		0.4		0.6		0.8		1.0	
	RPM	BHP	RPM	BHP	RPM	BHP	RPM	BHP	RPM	BHP
4500	487	0.98	552	1.26	610	1.55	665	1.86	718	2.20
4875	515	1.18	578	1.49	633	1.80	685	2.13	735	2.47
5250	544	1.42	604	1.75	657	2.09	707	2.43	754	2.78
5625	572	1.68	631	2.05	682	2.40	730	2.76	775	3.13
6000	601	1.98	657	2.37	707	2.75	753	3.13	797	3.52
6375	630	2.31	684	2.73	733	3.13	777	3.53	819	3.94
6750	659	2.68	711	3.12	759	3.55	802	3.98	843	4.40
7125	689	3.09	739	3.55	785	4.01	827	4.46	867	4.91
7500	718	3.53	766	4.02	811	4.51	852	4.98	891	5.46

CFM	Available External Static Pressure (in. wg)									
	1.2		1.4		1.6		1.8		2.0	
	RPM	BHP	RPM	BHP	RPM	BHP	RPM	BHP	RPM	BHP
4500	769	2.56	819	2.95	866	3.36	912	3.79	957	4.24
4875	784	2.84	831	3.23	877	3.65	921	4.09	964	4.54
5250	800	3.16	845	3.56	889	3.98	932	4.43	974	4.89
5625	819	3.52	862	3.93	903	4.36	944	4.81	985	5.28
6000	839	3.92	880	4.34	920	4.77	959	5.23	997	5.70
6375	860	4.36	899	4.79	937	5.23	975	5.70	-	-
6750	882	4.84	920	5.28	957	5.74	-	-	-	-
7125	904	5.36	941	5.82	-	-	-	-	-	-
7500	928	5.93	-	-	-	-	-	-	-	-

NOTE: For more information, see General Fan Performance Notes.
Boldface indicates field supplied drive is required.

Table 58 – 48TC16**

3 PHASE

15 TON HORIZONTAL SUPPLY

CFM	Available External Static Pressure (in. wg)									
	0.2		0.4		0.6		0.8		1.0	
	RPM	BHP	RPM	BHP	RPM	BHP	RPM	BHP	RPM	BHP
4500	479	0.97	540	1.23	596	1.50	651	1.80	703	2.13
4875	508	1.19	566	1.47	619	1.75	670	2.06	719	2.39
5250	537	1.43	592	1.73	643	2.03	691	2.35	737	2.69
5625	566	1.71	619	2.03	667	2.35	713	2.68	757	3.03
6000	596	2.02	646	2.36	692	2.70	736	3.05	778	3.41
6375	625	2.36	674	2.73	718	3.09	760	3.46	800	3.83
6750	655	2.75	701	3.14	744	3.52	785	3.91	824	4.30
7125	685	3.17	729	3.58	771	3.99	810	4.40	848	4.81
7500	715	3.64	758	4.07	798	4.50	836	4.93	872	5.36

CFM	Available External Static Pressure (in. wg)									
	1.2		1.4		1.6		1.8		2.0	
	RPM	BHP	RPM	BHP	RPM	BHP	RPM	BHP	RPM	BHP
4500	755	2.48	805	2.87	853	3.28	900	3.72	945	4.17
4875	768	2.75	815	3.14	862	3.55	907	3.99	951	4.45
5250	783	3.06	828	3.45	872	3.86	916	4.30	958	4.77
5625	800	3.40	843	3.80	885	4.21	926	4.66	967	5.12
6000	819	3.79	860	4.19	900	4.61	939	5.06	978	5.53
6375	840	4.23	878	4.63	916	5.06	954	5.51	991	5.98
6750	861	4.70	898	5.12	935	5.56	971	6.01	-	-
7125	884	5.23	919	5.66	-	-	-	-	-	-
7500	907	5.79	-	-	-	-	-	-	-	-

NOTE: For more information, see General Fan Performance Notes.
Boldface indicates field supplied drive is required.

FAN PERFORMANCE (cont.)

Table 59 – PULLEY ADJUSTMENT

UNIT	MOTOR/DRIVE COMBO	MOTOR PULLEY TURNS OPEN (RPM)											
		0.0	0.5	1.0	1.5	2.0	2.5	3.0	3.5	4.0	4.5	5.0	
04	1 phase	Standard Static	854	825	795	766	736	707	678	648	619	589	560
		Medium Static	1175	1135	1094	1054	1013	973	932	892	851	811	770
		High Static	–	–	–	–	–	–	–	–	–	–	–
	3 phase	Standard Static	854	825	795	766	736	707	678	648	619	589	560
		Medium Static	1175	1135	1094	1054	1013	973	932	892	851	811	770
		High Static	1466	1423	1380	1337	1294	1251	1207	1164	1121	1078	1035
05	1 phase	Standard Static	854	825	795	766	736	707	678	648	619	589	560
		Medium Static	1175	1135	1094	1054	1013	973	932	892	851	811	770
		High Static	–	–	–	–	–	–	–	–	–	–	–
	3 phase	Standard Static	854	825	795	766	736	707	678	648	619	589	560
		Medium Static	1175	1135	1094	1054	1013	973	932	892	851	811	770
		High Static	1466	1423	1380	1337	1294	1251	1207	1164	1121	1078	1035
06	1 phase	Standard Static	1175	1135	1094	1054	1013	973	932	892	851	811	770
		Medium Static	1466	1423	1380	1337	1294	1251	1207	1164	1121	1078	1035
		High Static	–	–	–	–	–	–	–	–	–	–	–
	3 phase	Standard Static	1175	1135	1094	1054	1013	973	932	892	851	811	770
		Medium Static	1466	1423	1380	1337	1294	1251	1207	1164	1121	1078	1035
		High Static	1687	1649	1610	1572	1533	1495	1457	1418	1380	1341	1303
07	3 phase	Standard Static	1457	1419	1380	1342	1303	1265	1227	1188	1150	1111	1073
		Medium Static	1518	1484	1449	1415	1380	1346	1311	1277	1242	1208	1173
		High Static	1788	1757	1725	1694	1662	1631	1600	1568	1537	1505	1474
08	3 phase	Standard Static	747	721	695	670	644	618	592	566	541	515	489
		Medium Static	949	927	906	884	863	841	819	798	776	755	733
		High Static	1102	1083	1063	1044	1025	1006	986	967	948	928	909
09	3 phase	Standard Static	733	712	690	669	647	626	604	583	561	540	518
		Medium Static	936	911	887	862	838	813	788	764	739	715	690
		High Static	1084	1059	1035	1010	986	961	936	912	887	863	838
12	3 phase	Standard Static	838	813	789	764	739	715	690	665	640	616	591
		Medium Static	1084	1059	1035	1010	986	961	936	912	887	863	838
		High Static	1240	1218	1196	1175	1153	1131	1109	1087	1066	1044	1022
14	3 phase	Standard Static	843	824	805	786	767	748	728	709	690	671	652
		Medium Static	1084	1059	1035	1010	986	961	936	912	887	863	838
		High Static	1240	1218	1196	1175	1153	1131	1109	1087	1066	1044	1022
16	3 phase	Standard Static	676	659	642	625	608	592	575	558	541	524	507
		Medium Static	851	829	806	784	761	739	717	694	672	649	627
		High Static	955	937	919	901	883	866	848	830	812	794	776

NOTE: Do not adjust pulley further than 5 turns open.

■ – Factory settings

ELECTRICAL DATA FOR UNITS PRODUCED ON OR AFTER JULY 30, 2012

NOTE: Check the serial number of unit to verify production date.

To confirm the date of manufacture, locate the unit nameplate and check the first four digits of the Serial Number. If the number listed in the first 4 digits of the Serial Number is 3112 or higher, the unit was produced on or after July 30, 2012.

Position:	1	2	3	4	5	6	7	8	9	10
Example:	3	1	1	2	U	1	2	3	4	5

Week of manufacture (fiscal calendar)			Sequence number
Year of manufacture ("12" = 2012)	Manufacturing location		

C12562A



ELECTRICAL INFORMATION
(UNITS PRODUCED ON OR AFTER JULY 30, 2012)

Table 60 – 48TC04 SINGLE STAGE COOLING WITH SINGLE SPEED INDOOR FAN MOTOR 3 TONS**

V-Ph-Hz	VOLTAGE RANGE		COMP (ea)		OFM (ea)		IFM		
	MIN	MAX	RLA	LRA	WATTS	FLA	TYPE	EFF at Full Load	FLA
208-1-60	187	253	16.6	79	325	1.5	STD	67%	4.9
					325	1.5	MED	67%	4.9
230-1-60	187	253	16.6	79	325	1.5	STD	67%	4.9
					325	1.5	MED	67%	4.9
208-3-60	187	253	10.4	73	325	1.5	STD	75%	5.2
					325	1.5	MED	75%	5.2
					325	1.5	HIGH	87%	6.9
230-3-60	187	253	10.4	73	325	1.5	STD	75%	5.2
					325	1.5	MED	75%	5.2
					325	1.5	HIGH	87%	6.7
460-3-60	414	506	5.8	38	325	0.8	STD	75%	2.6
					325	0.8	MED	75%	2.6
					325	0.8	HIGH	87%	3.4
575-3-60	518	633	3.8	37	325	0.6	STD	73%	2.4
					325	0.6	MED	73%	2.4
					325	0.6	HIGH	78%	2.0

Table 61 – 48TC05 SINGLE STAGE COOLING WITH SINGLE SPEED INDOOR FAN MOTOR 4 TONS**

V-Ph-Hz	VOLTAGE RANGE		COMP (ea)		OFM (ea)		IFM		
	MIN	MAX	RLA	LRA	WATTS	FLA	TYPE	EFF at Full Load	FLA
208-1-60	187	253	21.8	117	325	1.5	STD	67%	4.9
					325	1.5	MED	67%	4.9
230-1-60	187	253	21.8	117	325	1.5	STD	67%	4.9
					325	1.5	MED	67%	4.9
208-3-60	187	253	13.7	83	325	1.5	STD	75%	5.2
					325	1.5	MED	75%	5.2
					325	1.5	HIGH	87%	6.9
230-3-60	187	253	13.7	83	325	1.5	STD	75%	5.2
					325	1.5	MED	75%	5.2
					325	1.5	HIGH	87%	6.7
460-3-60	414	506	6.2	41	325	0.8	STD	75%	2.6
					325	0.8	MED	75%	2.6
					325	0.8	HIGH	87%	3.4
575-3-60	518	633	4.8	33	325	0.6	STD	73%	2.4
					325	0.6	MED	73%	2.4
					325	0.6	HIGH	78%	2.0

Table 62 – 48TC06 SINGLE STAGE COOLING WITH SINGLE SPEED INDOOR FAN MOTOR 5 TONS**

V-Ph-Hz	VOLTAGE RANGE		COMP (ea)		OFM (ea)		IFM		
	MIN	MAX	RLA	LRA	WATTS	FLA	TYPE	EFF at Full Load	FLA
208-1-60	187	253	26.2	134	325	1.5	STD	67%	4.9
					325	1.5	MED	76%	7.0
230-1-60	187	253	26.2	134	325	1.5	STD	67%	4.9
					325	1.5	MED	76%	7.0
208-3-60	187	253	15.6	110	325	1.5	STD	75%	5.2
					325	1.5	MED	87%	6.9
					325	1.5	HIGH	89%	8.4
230-3-60	187	253	15.6	110	325	1.5	STD	75%	5.2
					325	1.5	MED	87%	6.7
					325	1.5	HIGH	89%	8.3
460-3-60	414	506	7.7	52	325	0.8	STD	75%	2.6
					325	0.8	MED	87%	3.4
					325	0.8	HIGH	89%	4.2
575-3-60	518	633	5.8	39	325	0.6	STD	73%	2.4
					325	0.6	MED	78%	2.0
					325	0.6	HIGH	77%	2.8

ELECTRICAL INFORMATION
(UNITS PRODUCED ON OR AFTER JULY 30, 2012) cont.

Table 63 – 48TC07 SINGLE STAGE COOLING WITH SINGLE SPEED INDOOR FAN MOTOR 6 TONS**

V-Ph-Hz	VOLTAGE RANGE		COMP (ea)		OFM (ea)		IFM		
	MIN	MAX	RLA	LRA	WATTS	FLA	TYPE	EFF at Full Load	FLA
208-3-60	187	253	19.0	123	325	1.5	STD	87%	6.9
					325	1.5	MED	89%	8.4
					325	1.5	HIGH	87%	10.6
230-3-60	187	253	19.0	123	325	1.5	STD	87%	6.7
					325	1.5	MED	89%	8.3
					325	1.5	HIGH	87%	10.6
460-3-60	414	506	9.7	62	325	0.8	STD	87%	3.4
					325	0.8	MED	89%	4.2
					325	0.8	HIGH	87%	5.3
575-3-60	518	633	7.4	50	325	0.6	STD	78%	2.0
					325	0.6	MED	77%	2.8
					325	0.6	HIGH	77%	2.8

Table 64 – 48TC08 SINGLE STAGE COOLING WITH SINGLE SPEED INDOOR FAN MOTOR 7.5 TONS**

V-Ph-Hz	VOLTAGE RANGE		COMP (ea)		OFM (ea)		IFM		
	MIN	MAX	RLA	LRA	WATTS	FLA	TYPE	EFF at Full Load	FLA
208-3-60	187	253	25.0	164	325	1.5	STD	87%	5.2
					325	1.5	MED	89%	8.4
					325	1.5	HIGH	83%	13.6
230-3-60	187	253	25.0	164	325	1.5	STD	87%	4.9
					325	1.5	MED	89%	8.3
					325	1.5	HIGH	83%	12.7
460-3-60	414	506	12.2	100	325	0.8	STD	87%	2.5
					325	0.8	MED	89%	4.2
					325	0.8	HIGH	83%	6.4
575-3-60	518	633	9.0	78	325	0.6	STD	72%	1.6
					325	0.6	MED	77%	2.8
					325	0.6	HIGH	81%	5.6

Table 65 – 48TCD08 2-STAGE COOLING WITH SINGLE SPEED INDOOR FAN MOTOR 7.5 TONS**

V-Ph-Hz	VOLTAGE RANGE		COMP (Cir 1)		COMP (Cir 2)		OFM (ea)		IFM		
	MIN	MAX	RLA	LRA	RLA	LRA	WATTS	FLA	TYPE	EFF at Full Load	FLA
208-3-60	187	253	13.6	83	13.6	83	325	1.5	STD	87%	5.2
							325	1.5	MED	89%	8.4
							325	1.5	HIGH	83%	13.6
230-3-60	187	253	13.6	83	13.6	83	325	1.5	STD	87%	4.9
							325	1.5	MED	89%	8.3
							325	1.5	HIGH	83%	12.7
460-3-60	414	506	6.1	41	6.1	41	325	0.8	STD	87%	2.5
							325	0.8	MED	89%	4.2
							325	0.8	HIGH	83%	6.4
575-3-60	518	633	4.2	33	4.2	33	325	0.6	STD	72%	1.6
							325	0.6	MED	77%	2.8
							325	0.6	HIGH	81%	5.6

ELECTRICAL INFORMATION
(UNITS PRODUCED ON OR AFTER JULY 30, 2012) cont.

Table 66 – 48TC*D08 2-STAGE COOLING WITH 2 SPEED INDOOR FAN MOTOR

7.5 TONS

V-Ph-Hz	VOLTAGE RANGE		COMP 1		COMP 2		OFM (ea)		IFM		
	MIN	MAX	RLA	LRA	RLA	LRA	WATTS	FLA	TYPE	EFF at Full Load	FLA
208-3-60	187	253	13.6	83	13.6	83	325	1.5	STD	0.84	5.8
							325	1.5	MED	0.85	8.6
							325	1.5	HIGH	0.84	13.6
230-3-60	187	253	13.6	83	13.6	83	325	1.5	STD	0.84	5.6
							325	1.5	MED	0.85	7.8
							325	1.5	HIGH	0.84	12.7
460-3-60	414	506	6.1	41	6.1	41	325	0.8	STD	0.79	2.9
							325	0.8	MED	0.85	3.8
							325	0.8	HIGH	0.84	6.4
575-3-60	518	633	4.2	33	4.2	33	325	0.6	STD	0.81	2.8
							325	0.6	MED	0.84	4.5
							325	0.6	HIGH	0.83	6.2

Table 67 – 48TC09 SINGLE STAGE COOLING WITH SINGLE SPEED INDOOR FAN MOTOR 8.5 TONS**

V-Ph-Hz	VOLTAGE RANGE		COMP (ea)		OFM (ea)		IFM		
	MIN	MAX	RLA	LRA	WATTS	FLA	TYPE	EFF at Full Load	FLA
208-3-60	187	253	29.5	195	325	1.5	STD	87%	5.2
					325	1.5	MED	87%	6.9
					325	1.5	HIGH	87%	10.6
230-3-60	187	253	29.5	195	325	1.5	STD	87%	4.9
					325	1.5	MED	87%	6.7
					325	1.5	HIGH	87%	10.6
460-3-60	414	506	14.7	95	325	0.8	STD	87%	2.5
					325	0.8	MED	87%	3.4
					325	0.8	HIGH	87%	5.3
575-3-60	518	633	12.2	80	325	0.6	STD	72%	1.6
					325	0.6	MED	78%	2.0
					325	0.6	HIGH	77%	2.8

Table 68 – 48TC09 2-STAGE COOLING WITH SINGLE SPEED INDOOR FAN MOTOR**

8.5 TONS

V-Ph-Hz	VOLTAGE RANGE		COMP (Cir 1)		COMP (Cir 2)		OFM (ea)		IFM		
	MIN	MAX	RLA	LRA	RLA	LRA	WATTS	FLA	TYPE	EFF at Full Load	FLA
208-3-60	187	253	14.5	98	13.7	83	325	1.5	STD	87%	5.2
							325	1.5	MED	87%	6.9
							325	1.5	HIGH	87%	10.6
230-3-60	187	253	14.5	98	13.7	83	325	1.5	STD	87%	4.9
							325	1.5	MED	87%	6.7
							325	1.5	HIGH	87%	10.6
460-3-60	414	506	6.3	55	6.2	41	325	0.8	STD	87%	2.5
							325	0.8	MED	87%	3.4
							325	0.8	HIGH	87%	5.3
575-3-60	518	633	6.0	41	4.8	33	325	0.6	STD	72%	1.6
							325	0.6	MED	78%	2.0
							325	0.6	HIGH	77%	2.8

ELECTRICAL INFORMATION
(UNITS PRODUCED ON OR AFTER JULY 30, 2012) cont.

Table 69 – 48TC*D09 2-STAGE COOLING WITH 2 SPEED INDOOR FAN MOTOR

8.5 TONS

V-Ph-Hz	VOLTAGE RANGE		COMP 1		COMP 2		OFM (ea)		IFM		
	MIN	MAX	RLA	LRA	RLA	LRA	WATTS	FLA	TYPE	EFF at Full Load	FLA
208-3-60	187	253	14.5	98	13.7	83	325	1.5	STD	0.84	5.8
							325	1.5	MED	0.77	7.1
							325	1.5	HIGH	0.82	10.8
230-3-60	187	253	14.5	98	13.7	83	325	1.5	STD	0.84	5.6
							325	1.5	MED	0.77	6.8
							325	1.5	HIGH	0.82	9.8
460-3-60	414	506	6.3	55	6.2	41	325	0.8	STD	0.79	2.9
							325	0.8	MED	0.77	3.8
							325	0.8	HIGH	0.82	4.9
575-3-60	518	633	6.0	41	4.8	33	325	0.6	STD	0.81	2.8
							325	0.6	MED	0.80	3.5
							325	0.6	HIGH	0.84	4.5

Table 70 – 48TC12 SINGLE STAGE COOLING WITH SINGLE SPEED INDOOR FAN MOTOR**

10 TONS

V-Ph-Hz	VOLTAGE RANGE		COMP (ea)		OFM (ea)		IFM		
	MIN	MAX	RLA	LRA	WATTS	FLA	TYPE	EFF at Full Load	FLA
208-3-60	187	253	30.1	225	325	1.5	STD	87%	6.9
					325	1.5	MED	87%	10.6
					325	1.5	HIGH	83%	13.6
230-3-60	187	253	30.1	225	325	1.5	STD	87%	6.7
					325	1.5	MED	87%	10.6
					325	1.5	HIGH	83%	12.7
460-3-60	414	506	16.7	114	325	0.8	STD	87%	3.4
					325	0.8	MED	87%	5.3
					325	0.8	HIGH	83%	6.4
575-3-60	518	633	12.2	80	325	0.6	STD	78%	2.0
					325	0.6	MED	77%	2.8
					325	0.6	HIGH	81%	5.6

Table 71 – 48TC12 2-STAGE COOLING WITH SINGLE SPEED INDOOR FAN MOTOR**

10 TONS

V-Ph-Hz	VOLTAGE RANGE		COMP (Cir 1)		COMP (Cir 2)		OFM (ea)		IFM		
	MIN	MAX	RLA	LRA	RLA	LRA	WATTS	FLA	TYPE	EFF at Full Load	FLA
208-3-60	187	253	15.6	110	15.9	110	325	1.5	STD	87%	6.9
							325	1.5	MED	87%	10.6
							325	1.5	HIGH	83%	13.6
230-3-60	187	253	15.6	110	15.9	110	325	1.5	STD	87%	6.7
							325	1.5	MED	87%	10.6
							325	1.5	HIGH	83%	12.7
460-3-60	414	506	7.7	52	7.7	52	325	0.8	STD	87%	3.4
							325	0.8	MED	87%	5.3
							325	0.8	HIGH	83%	6.4
575-3-60	518	633	5.8	39	5.7	39	325	0.6	STD	78%	2.0
							325	0.6	MED	77%	2.8
							325	0.6	HIGH	81%	5.6

ELECTRICAL INFORMATION
(UNITS PRODUCED ON OR AFTER JULY 30, 2012) cont.

Table 72 – 48TC*D12 2-STAGE COOLING WITH 2 SPEED INDOOR FAN MOTOR

10 TONS

V-Ph-Hz	VOLTAGE RANGE		COMP 1		COMP 2		OFM (ea)		IFM		
	MIN	MAX	RLA	LRA	RLA	LRA	WATTS	FLA	TYPE	EFF at Full Load	FLA
208-3-60	187	253	15.6	110	15.9	110	325	1.5	STD	0.77	7.1
							325	1.5	MED	0.82	10.8
							325	1.5	HIGH	0.84	13.6
230-3-60	187	253	15.6	110	15.9	110	325	1.5	STD	0.77	6.8
							325	1.5	MED	0.82	9.8
							325	1.5	HIGH	0.84	12.7
460-3-60	414	506	7.7	52	7.7	52	325	0.8	STD	0.77	3.8
							325	0.8	MED	0.82	4.9
							325	0.8	HIGH	0.84	6.4
575-3-60	518	633	5.8	39	5.7	39	325	0.6	STD	0.80	3.5
							325	0.6	MED	0.84	4.5
							325	0.6	HIGH	0.83	6.2

Table 73 – 48TC14 2-STAGE COOLING WITH SINGLE SPEED INDOOR FAN MOTOR**

12.5 TONS

V-Ph-Hz	VOLTAGE RANGE		COMP (Cir 1)		COMP (Cir 2)		OFM (ea)		IFM		
	MIN	MAX	RLA	LRA	RLA	LRA	WATTS	FLA	TYPE	EFF at Full Load	FLA
208-3-60	187	253	19.0	123	22.4	149	1070	6.2	STD	89%	8.4
							1070	6.2	MED	87%	10.6
							1070	6.2	HIGH	83%	13.6
230-3-60	187	253	19.0	123	22.4	149	1070	6.2	STD	89%	8.3
							1070	6.2	MED	87%	10.6
							1070	6.2	HIGH	83%	12.7
460-3-60	414	506	9.7	62	10.6	75	1070	3.1	STD	89%	4.2
							1070	3.1	MED	87%	5.3
							1070	3.1	HIGH	83%	6.4
575-3-60	518	633	7.4	50	7.7	54	1070	2.5	STD	77%	2.8
							1070	2.5	MED	77%	2.8
							1070	2.5	HIGH	81%	5.6

Table 74 – 48TC*D14 2-STAGE COOLING WITH 2 SPEED INDOOR FAN MOTOR

12.5 TONS

V-Ph-Hz	VOLTAGE RANGE		COMP 1		COMP 2		OFM (ea)		IFM		
	MIN	MAX	RLA	LRA	RLA	LRA	WATTS	FLA	TYPE	EFF at Full Load	FLA
208-3-60	187	253	19.0	123	22.4	149	1070	6.2	STD	0.85	8.6
							1070	6.2	MED	0.82	10.8
							1070	6.2	HIGH	0.84	13.6
230-3-60	187	253	19.0	123	22.4	149	1070	6.2	STD	0.85	7.8
							1070	6.2	MED	0.82	9.8
							1070	6.2	HIGH	0.84	12.7
460-3-60	414	506	9.7	62	10.6	75	1070	3.1	STD	0.85	3.8
							1070	3.1	MED	0.82	4.9
							1070	3.1	HIGH	0.84	6.4
575-3-60	518	633	7.4	50	7.7	54	1070	2.5	STD	0.84	4.5
							1070	2.5	MED	0.84	4.5
							1070	2.5	HIGH	0.83	6.2

ELECTRICAL INFORMATION
(UNITS PRODUCED ON OR AFTER JULY 30, 2012) cont.

Table 75 – 48TC*D16 2-STAGE COOLING WITH SINGLE SPEED INDOOR FAN MOTOR 15 TONS

V-Ph-Hz	VOLTAGE RANGE		COMP (Cir 1)		COMP (Cir 2)		OFM (ea)		IFM		
	MIN	MAX	RLA	LRA	RLA	LRA	WATTS	FLA	TYPE	EFF at Full Load	FLA
208-3-60	187	253	25.0	164	25.0	164	280	1.5	STD	89%	8.4
							280	1.5	MED	87%	10.6
							280	1.5	HIGH	90%	20.4
230-3-60	187	253	25.0	164	25.0	164	280	1.5	STD	89%	8.3
							280	1.5	MED	87%	10.6
							280	1.5	HIGH	90%	20.4
460-3-60	414	506	12.2	100	12.8	100	280	0.8	STD	89%	4.2
							280	0.8	MED	87%	5.3
							280	0.8	HIGH	90%	10.2
575-3-60	518	633	9.8	78	9.6	78	280	0.6	STD	77%	2.8
							280	0.6	MED	77%	2.8
							280	0.6	HIGH	94%	9.0

Table 76 – 48TC*D16 2-STAGE COOLING WITH 2 SPEED INDOOR FAN MOTOR 15 TONS

V-Ph-Hz	VOLTAGE RANGE		COMP 1		COMP 2		OFM (ea)		IFM		
	MIN	MAX	RLA	LRA	RLA	LRA	WATTS	FLA	TYPE	EFF at Full Load	FLA
208-3-60	187	253	25.0	164	25.0	164	280	1.5	STD	0.85	8.6
							280	1.5	MED	0.82	10.8
							280	1.5	HIGH	0.90	20.4
230-3-60	187	253	25.0	164	25.0	164	280	1.5	STD	0.85	7.8
							280	1.5	MED	0.82	9.8
							280	1.5	HIGH	0.90	20.4
460-3-60	414	506	12.2	100	12.8	100	280	0.8	STD	0.85	3.8
							280	0.8	MED	0.82	4.9
							280	0.8	HIGH	0.90	10.2
575-3-60	518	633	9.8	78	9.6	78	280	0.6	STD	0.84	4.5
							280	0.6	MED	0.84	4.5
							280	0.6	HIGH	0.94	9

**ELECTRICAL INFORMATION
(UNITS PRODUCED ON OR AFTER JULY 30, 2012) cont.**

Table 77 – UNIT WIRE/FUSE OR HACR BREAKER SIZING DATA WITH SINGLE SPEED INDOOR FAN MOTOR

UNIT	NOM. V-Ph-Hz	IFM TYPE	NO C.O. or UNPWR C.O.						w/ PWRD C.O.								
			NO P.E.			w/ P.E. (pwrd fr/ unit)			NO P.E.			w/ P.E. (pwrd fr/ unit)					
			MCA	MAX FUSE or HACR BRKR	DISC. SIZE FLA LRA	MCA	MAX FUSE or HACR BRKR	DISC. SIZE FLA LRA	MCA	MAX FUSE or HACR BRKR	DISC. SIZE FLA LRA	MCA	MAX FUSE or HACR BRKR	DISC. SIZE FLA LRA			
48TC**04	208/230-1-60	STD	28	40	26	95	30	45	29	97	32	100	34	50	34	102	
		MED	28	40	26	95	30	45	29	97	32	100	34	50	34	102	
	208/230-3-60	STD	20	30	20	96	22	30	22	98	25	101	27	30	27	103	
		MED	20	30	20	96	22	30	22	98	25	101	27	30	27	103	
	460-3-60	HIGH	22/22	30/30	22/21	134	24/24	30/30	24/24	136	27/26	139	29/28	35/35	29/29	141	
		STD	11	15	11	49	12	15	12	50	13	51	14	20	14	52	
	575-3-60	MED	11	15	11	49	12	15	12	50	13	51	14	20	14	52	
		HIGH	12	15	12	68	13	15	13	69	14	70	15	20	15	71	
	208/230-1-60	STD	8	15	8	46	10	15	10	48	10	48	12	15	12	50	
		MED	8	15	8	46	10	15	10	48	10	48	12	15	12	50	
	48TC**05	208/230-1-60	HIGH	8	15	7	50	10	15	10	52	10	52	11	15	12	54
			STD	34	50	32	133	36	50	35	135	39	138	41	60	40	140
208/230-3-60		MED	34	50	32	133	36	50	35	135	39	138	41	60	40	140	
		STD	24	30	23	106	26	30	26	108	29	111	31	40	31	113	
460-3-60		MED	24	30	23	106	26	30	26	108	29	111	31	40	31	113	
		HIGH	26/26	30/30	25/25	144	28/28	40/40	28/27	146	31/31	149	33/32	45/45	33/33	151	
575-3-60		STD	12	15	11	52	13	15	12	53	14	54	15	20	15	55	
		MED	12	15	11	52	13	15	12	53	14	54	15	20	15	55	
575-3-60		HIGH	12	15	12	71	13	15	13	72	15	73	16	20	16	74	
		STD	9	15	9	42	11	15	11	44	11	44	13	15	13	46	
575-3-60		MED	9	15	9	42	11	15	11	44	11	44	13	15	13	46	
		HIGH	9	15	9	46	11	15	11	48	11	48	13	15	13	50	

**ELECTRICAL INFORMATION
(UNITS PRODUCED ON OR AFTER JULY 30, 2012) cont.**

Table 77 - UNIT WIRE/FUSE OR HACR BREAKER SIZING DATA WITH SINGLE SPEED INDOOR FAN MOTOR (cont.)

UNIT	NOM. V-Ph-Hz	IFM TYPE	NO C.O. or UNPWR C.O.						w/ PWRD C.O.											
			NO P.E.			w/ P.E. (pwrd fr/ unit)			NO P.E.			w/ P.E. (pwrd fr/ unit)								
			MCA	MAX FUSE or HACR BRKR	DISC. SIZE FLA LRA	MCA	MAX FUSE or HACR BRKR	DISC. SIZE FLA LRA	MCA	MAX FUSE or HACR BRKR	DISC. SIZE FLA LRA	MCA	MAX FUSE or HACR BRKR	DISC. SIZE FLA LRA						
48TC**06	208/230-1-60	STD	40	60	37	150	42	60	40	152	44	44	60	43	155	46	60	45	157	
		MED	42	60	40	175	44	60	42	177	47	47	60	45	180	48	60	48	182	
		STD	27	40	26	133	29	40	28	135	31	31	45	31	138	33	45	33	140	
	208/230-3-60	MED	28/28	40/40	28/27	171	30/30	45/45	30/30	173	33/33	33/33	33/33	45/45	33/33	176	35/35	50/50	35/35	178
		HIGH	30/30	45/40	29/29	186	32/32	45/45	32/31	188	35/35	35/35	45/45	35/35	191	37/36	50/50	37/37	193	
		STD	13	20	13	63	14	20	14	64	16	16	20	15	65	17	20	16	66	
	460-3-60	MED	14	20	14	82	15	20	15	83	16	16	20	16	84	17	20	17	85	
		HIGH	15	20	15	90	16	20	16	91	17	17	20	17	92	18	25	18	93	
		STD	11	15	10	48	13	15	12	50	12	12	15	12	50	14	20	14	52	
	575-3-60	MED	10	15	10	52	12	15	12	54	12	12	15	12	54	14	15	14	56	
		HIGH	11	15	11	63	13	15	13	65	13	13	15	13	65	15	20	15	67	
		STD	33/32	50/50	32/31	184	35/34	50/50	34/33	186	37/37	37/37	50/50	37/37	189	39/39	50/50	39/39	191	
48TC**07	208/230-3-60	MED	34/34	50/50	33/33	199	36/36	50/50	35/35	201	39/39	39/39	50/50	39/39	204	41/41	50/50	41/41	206	
		HIGH	36	50	36	213	38	50	38	215	41	41	50	41	218	43	60	43	220	
		STD	17	25	16	92	18	25	17	93	19	19	25	19	94	20	25	20	95	
460-3-60	MED	18	25	17	100	19	25	18	101	20	20	25	19	102	21	30	21	103		
	HIGH	19	25	18	107	20	25	19	108	21	21	30	21	109	22	30	22	110		
	STD	12	15	12	63	14	20	14	65	14	14	20	13	65	16	20	16	67		
575-3-60	MED	13	20	12	74	15	20	15	76	15	15	20	14	76	17	20	17	78		
	HIGH	13	20	12	74	15	20	15	76	15	15	20	14	76	17	20	17	78		
	STD	40/40	60/60	38/38	208	44/43	60/60	43/42	212	45/44	45/44	60/60	44/43	213	49/48	60/60	48/48	217		
48TC*A08	208/230-3-60	MED	43/43	60/60	42/42	244	47/47	60/60	46/46	248	48/48	48/48	60/60	47/47	249	52/52	60/60	52/52	253	
		HIGH	48/47	60/60	48/47	260	52/51	60/60	52/51	264	53/52	53/52	60/60	53/52	265	57/56	80/80	58/57	269	
		STD	20	30	19	122	22	30	21	124	22	22	30	21	124	24	30	23	126	
460-3-60	MED	22	30	21	140	23	30	23	142	24	24	30	23	142	26	30	25	144		
	HIGH	24	30	23	148	26	30	25	150	26	26	30	26	150	28	35	28	152		
	STD	15	20	14	89	18	25	18	93	16	16	20	16	91	20	25	20	95		
575-3-60	MED	16	20	15	104	20	25	19	108	17	17	25	17	106	21	25	21	110		
	HIGH	19	25	18	118	22	30	23	122	20	20	25	20	120	24	30	24	124		

**ELECTRICAL INFORMATION
(UNITS PRODUCED ON OR AFTER JULY 30, 2012) cont.**

Table 77 - UNIT WIRE/FUSE OR HACR BREAKER SIZING DATA WITH SINGLE SPEED INDOOR FAN MOTOR (cont.)

UNIT	NOM. V-Ph-Hz	IFM TYPE	NO C.O. or UNPWR C.O.						w/ PWRD C.O.										
			NO PE.			w/ P.E. (pwrd fr/ unit)			NO PE.			w/ P.E. (pwrd fr/ unit)							
			MCA	MAX FUSE or HACR BRKR	DISC. SIZE FLA LRA	MCA	MAX FUSE or HACR BRKR	DISC. SIZE FLA LRA	MCA	MAX FUSE or HACR BRKR	DISC. SIZE FLA LRA	MCA	MAX FUSE or HACR BRKR	DISC. SIZE FLA LRA					
48TC*D08	208/230-3-60	STD	39/39	50/50	41/40	210	43/43	50/50	45/45	214	44/44	50/50	48/46	215	48/48	60/60	51/50	219	
		MED	42/42	50/50	44/44	246	46/46	50/50	49/49	250	47/47	60/60	50/50	50/50	251	51/51	60/60	54/54	255
		HIGH	48/47	60/50	50/49	262	51/51	60/60	55/54	266	52/52	60/60	56/55	267	56/55	60/60	60/59	271	
	460-3-60	STD	18	20	19	104	20	25	21	106	20	25	21	106	22	22	25	23	108
		MED	20	25	21	122	22	25	23	124	22	25	23	124	24	24	30	25	126
		HIGH	22	25	23	130	24	30	25	132	24	30	26	132	26	26	30	28	134
48TC*A09	575-3-60	STD	13	15	13	77	17	20	17	81	14	15	15	79	18	20	19	83	
		MED	14	15	14	92	18	20	19	96	16	20	16	94	19	25	21	98	
		HIGH	17	20	17	106	21	25	22	110	19	20	19	108	23	25	24	112	
	208/230-3-60	STD	46/45	60/60	43/43	239	49/49	60/60	48/47	243	50/50	60/60	49/49	244	54/54	80/80	53/53	248	
		MED	47/47	60/60	45/45	260	51/51	60/60	50/49	264	52/52	60/60	51/51	265	56/56	80/80	55/55	269	
		HIGH	51	60	50	289	55	80	54	293	56	80	55	294	60	80	59	298	
48TC*D09	208/230-3-60	STD	23	30	22	117	25	30	24	119	25	30	24	119	27	40	26	121	
		MED	24	30	23	127	26	30	25	129	26	30	25	129	28	40	27	131	
		HIGH	26	30	25	142	28	40	27	144	28	40	27	144	30	40	29	146	
	575-3-60	STD	19	30	17	91	22	30	22	95	20	30	19	93	24	30	24	97	
		MED	19	30	18	95	23	30	22	99	21	30	20	97	24	30	24	101	
		HIGH	20	30	19	106	24	30	23	110	21	30	21	108	25	30	25	112	
48TC*D09	208/230-3-60	STD	40/40	50/50	42/42	225	44/44	50/50	46/46	229	45/45	50/50	47/47	230	49/49	60/60	52/51	234	
		MED	42/42	50/50	44/44	246	46/46	60/50	48/48	250	47/47	60/60	49/49	251	51/51	60/60	54/53	255	
		HIGH	46	50	48	275	50	60	52	279	51	60	54	280	54	60	58	284	
	460-3-60	STD	19	20	19	118	20	25	21	120	21	25	22	120	23	25	24	122	
		MED	20	25	20	128	21	25	22	130	22	25	23	130	24	25	25	132	
		HIGH	21	25	22	143	23	25	24	145	24	25	25	145	25	30	27	147	
575-3-60	STD	16	20	16	85	19	25	20	89	17	20	18	87	21	25	22	91		
	MED	16	20	16	89	20	25	20	93	18	20	18	91	21	25	22	95		
	HIGH	17	20	17	100	21	25	21	104	18	20	19	102	22	25	23	106		

**ELECTRICAL INFORMATION
(UNITS PRODUCED ON OR AFTER JULY 30, 2012) cont.**

Table 77 - UNIT WIRE/FUSE OR HACR BREAKER SIZING DATA WITH SINGLE SPEED INDOOR FAN MOTOR (cont.)

UNIT	NOM. V-Ph-Hz	IFM TYPE	NO C.O. or UNPWR C.O.						w/ PWRD C.O.									
			NO PE.			w/ P.E. (pwrdr fr/ unit)			NO PE.			w/ P.E. (pwrdr fr/ unit)						
			MCA	MAX FUSE or HACR BRKR	DISC. SIZE FLA LRA	MCA	MAX FUSE or HACR BRKR	DISC. SIZE FLA LRA	MCA	MAX FUSE or HACR BRKR	DISC. SIZE FLA LRA	MCA	MAX FUSE or HACR BRKR	DISC. SIZE FLA LRA				
48TC*A12	208/230-3-60	STD	48/48	60/60	46/46	290	52/52	60/60	50/50	294	53/53	60/60	52/51	295	57/56	80/80	56/56	299
		MED	52	60	50	319	55	80	55	323	56	80	56	324	60	80	60	328
		HIGH	55/54	80/80	54/53	321	58/58	80/80	58/57	325	59/59	80/80	59/58	326	63/62	80/80	64/63	330
	460-3-60	STD	26	40	25	146	28	40	27	148	29	40	27	148	30	45	30	150
		MED	28	40	27	161	30	45	29	163	30	45	30	163	32	45	32	165
		HIGH	29	45	28	162	31	45	30	164	32	45	31	164	33	45	33	166
48TC*D12	208/230-3-60	STD	19	30	18	95	23	30	22	99	21	30	20	97	24	30	24	101
		MED	20	30	19	106	24	30	23	110	21	30	21	108	25	30	25	112
		HIGH	23	30	22	120	26	30	26	124	24	30	24	122	28	35	28	126
	460-3-60	STD	46/46	60/60	48/47	285	50/49	60/60	52/52	289	51/50	60/60	53/53	290	54/54	60/60	56/57	294
		MED	50	60	52	314	53	60	56	318	54	60	57	319	58	70	62	323
		HIGH	53/52	60/60	55/54	316	56/55	60/60	60/59	320	57/56	70/60	61/60	321	61/60	70/70	65/64	325
48TC*D14	208/230-3-60	STD	23	30	23	136	25	30	26	138	25	30	26	138	27	30	28	140
		MED	25	30	26	151	26	30	28	153	27	30	28	153	29	35	30	155
		HIGH	26	30	27	152	28	30	29	154	28	30	29	154	30	35	32	156
	460-3-60	STD	17	20	17	93	20	25	21	97	18	20	19	95	22	25	23	99
		MED	17	20	18	104	21	25	22	108	19	25	20	106	23	25	24	110
		HIGH	20	25	21	118	24	30	25	122	22	25	23	120	26	30	27	124
575-3-60	STD	62/62	80/80	64/64	376	66/66	80/80	69/69	380	67/67	80/80	70/70	381	71/71	80/80	74/74	385	
	MED	64	80	67	390	68	80	71	394	69	80	72	395	73	80	77	399	
	HIGH	67/66	80/80	70/69	392	71/70	80/80	75/74	396									
48TC*D14	208/230-3-60	STD	31	40	32	189	33	40	34	191	33	40	34	191	35	40	36	193
		MED	32	40	33	196	34	40	35	198	34	40	36	198	36	45	38	200
		HIGH	33	40	34	197	35	40	36	199	35	45	37	199	37	45	39	201
	460-3-60	STD	23	30	23	142	27	30	28	146	24	30	25	144	28	30	30	148
		MED	23	30	23	142	27	30	28	146	24	30	25	144	28	30	30	148
		HIGH	26	30	27	156	29	35	31	160	27	35	29	158	31	35	33	162

ELECTRICAL INFORMATION (UNITS PRODUCED ON OR AFTER JULY 30, 2012) cont.

Table 77 - UNIT WIRE/FUSE OR HACR BREAKER SIZING DATA WITH SINGLE SPEED INDOOR FAN MOTOR (cont.)

UNIT	NOM. V-Ph-Hz	IFM TYPE	NO C.O. or UNPWR C.O.			NO PE.			w/ PWRD C.O.									
			MCA	DISC. SIZE		MAX FUSE or HACR BRKR	MCA	DISC. SIZE		MAX FUSE or HACR BRKR	MCA	DISC. SIZE						
				FLA	LRA			FLA	LRA			FLA	LRA					
48TC*D16	208/230-3-60	STD	70/70	72/72	412	73/73	80/80	77/77	416	74/74	90/90	78/78	417	78/78	100/100	82/82	421	
		MED	72	75	426	76	100	79	430	77	77	100	80	431	80	100	85	435
		HIGH	82	86	432	85	100	91	436	86	86	100	92	437	90	100	96	441
	460-3-60	STD	35	36	242	37	45	38	244	37	37	45	39	244	39	50	41	246
		MED	36	38	249	38	50	40	251	39	39	50	40	251	40	50	42	253
		HIGH	41	43	252	43	50	45	254	43	43	50	46	254	45	50	48	256
575-3-60	STD	27	30	28	184	31	40	32	188	29	35	30	186	32	40	34	190	
	MED	27	30	28	184	31	40	32	188	29	35	30	186	32	40	34	190	
	HIGH	33	40	35	196	37	45	39	200	35	40	37	198	39	45	41	202	

LEGEND:

- BRKR Circuit breaker
- CO Convenience outlet
- DISC Disconnect
- FLA Full load amps
- IFM Indoor fan motor
- LRA Locked rotor amps
- MCA Minimum circuit amps
- MOCP MAX FUSE or HACR Breaker
- PE Power exhaust
- PWRD CO Powered convenient outlet
- UNPWR CO Unpowered convenient outlet



Example: Supply voltage is 230-3-60



AB = 224 V
BC = 231 V
AC = 226 V

$$\text{Average Voltage} = \frac{(224 + 231 + 226)}{3} = \frac{681}{3} = 227$$

Determine maximum deviation from average voltage.

$$(AB) 227 - 224 = 3 \text{ V}$$

$$(BC) 231 - 227 = 4 \text{ V}$$

$$(AC) 227 - 226 = 1 \text{ V}$$

Maximum deviation is 4 v.

Determine percent of voltage imbalance.

$$\% \text{ Voltage Imbalance} = 100 \times \frac{4}{227} = 1.76\%$$

$$\% \text{ Voltage Imbalance} = 100 \times \frac{\text{max voltage deviation from average voltage}}{\text{average voltage}}$$

This amount of phase imbalance is satisfactory as it is below the maximum allowable 2%.
IMPORTANT: If the supply voltage phase imbalance is more than 2%, contact your local electric utility company immediately.

**ELECTRICAL INFORMATION
(UNITS PRODUCED ON OR AFTER JULY 30, 2012) cont.**

Table 78 – UNIT WIRE/FUSE OR HACR BREAKER SIZING DATA WITH 2 SPEED INDOOR FAN MOTOR

UNIT	NOM. V-Ph-Hz	IFM TYPE	NO C.O. or UNPWR C.O.						w/ PWRD C.O.									
			NO PE.			w/ P.E. (pwrd fr/ unit)			NO PE.			w/ P.E. (pwrd fr/ unit)						
			MCA	MAX FUSE or HACR BRKR	DISC. SIZE FLA LRA	MCA	MAX FUSE or HACR BRKR	DISC. SIZE FLA LRA	MCA	MAX FUSE or HACR BRKR	DISC. SIZE FLA LRA	MCA	MAX FUSE or HACR BRKR	DISC. SIZE FLA LRA				
48TC*D08	208/230-3-60	STD	40/40	50/50	41/41	197	44/43	50/50	46/46	201	45/44	50/50	47/47	202	48/48	60/60	51/51	206
		MED	43/42	50/50	45/44	227	46/46	50/50	49/48	231	47/47	60/50	50/49	232	51/50	60/60	55/54	236
		HIGH	48/47	60/50	50/49	262	51/51	60/60	55/54	266	52/52	60/60	59/55	267	56/55	60/60	60/59	271
	460-3-60	STD	19	20	19	97	20	25	21	99	21	25	22	99	23	25	24	101
		MED	20	25	20	113	21	25	22	115	22	25	23	115	24	25	25	117
		HIGH	22	25	23	130	24	30	25	132	25	30	26	132	26	30	28	134
48TC*D09	208/230-3-60	STD	14	15	14	79	18	20	19	83	16	20	16	81	19	25	21	85
		MED	16	20	16	92	19	25	21	96	17	20	18	94	21	25	23	98
		HIGH	18	20	18	106	22	25	23	110	20	25	20	108	23	25	24	112
	460-3-60	STD	41/41	50/50	43/42	212	45/45	50/50	47/47	216	46/46	50/50	48/48	217	50/49	60/60	52/52	221
		MED	42/42	50/50	44/44	216	46/46	60/50	48/48	220	47/47	60/60	50/49	221	51/51	60/60	54/54	225
		HIGH	46/45	60/50	48/47	266	50/49	60/60	53/52	270	51/50	60/60	54/53	271	55/54	60/60	58/57	275
48TC*D12	208/230-3-60	STD	19	25	20	111	21	25	22	113	21	25	22	113	23	25	24	115
		MED	20	25	21	114	22	25	23	116	22	25	23	116	24	30	25	118
		HIGH	21	25	22	139	23	25	24	141	23	25	24	141	25	30	26	143
	575-3-60	STD	17	20	17	87	21	25	21	91	18	20	19	89	22	25	23	93
		MED	17	20	18	91	21	25	22	95	19	25	20	93	23	25	24	97
		HIGH	18	20	19	100	22	25	23	104	20	25	21	102	24	30	25	106
48TC*D12	208/230-3-60	STD	46/46	60/60	48/47	255	50/50	60/60	52/52	259	51/51	60/60	53/53	260	55/54	60/60	58/57	264
		MED	50/49	60/60	52/51	305	54/53	60/60	56/55	309	55/54	60/60	58/56	310	58/57	70/70	62/61	314
		HIGH	53/52	60/60	55/54	316	56/55	60/60	60/59	320	57/56	70/60	61/60	321	61/60	70/70	65/64	325
	460-3-60	STD	23	30	24	122	25	30	26	124	25	30	26	124	27	30	29	126
		MED	24	30	25	147	26	30	27	149	26	30	28	149	28	30	30	151
		HIGH	26	30	27	152	28	30	29	154	28	30	29	154	30	35	32	156
575-3-60	STD	18	20	19	95	22	25	23	99	20	25	21	97	24	25	25	101	
	MED	19	25	20	104	23	25	24	108	21	25	22	106	25	30	26	110	
	HIGH	21	25	22	118	25	30	26	122	23	25	24	120	26	30	28	124	

**ELECTRICAL INFORMATION
(UNITS PRODUCED ON OR AFTER JULY 30, 2012) cont.**

Table 78 - UNIT WIRE/FUSE OR HACR BREAKER SIZING DATA WITH 2 SPEED INDOOR FAN MOTOR (cont.)

UNIT	NOM. V-Ph-Hz	IFM TYPE	NO C.O. or UNPWR C.O.						w/ PWRD C.O.									
			NO P.E.			w/ P.E. (pwrdr fr/ unit)			NO P.E.			w/ P.E. (pwrdr fr/ unit)						
			MCA	MAX FUSE or HACR BRKR	DISC. SIZE FLA LRA	MCA	MAX FUSE or HACR BRKR	DISC. SIZE FLA LRA	MCA	MAX FUSE or HACR BRKR	DISC. SIZE FLA LRA	MCA	MAX FUSE or HACR BRKR	DISC. SIZE FLA LRA				
48TC*D14	208/230-3-60	STD	62/61	80/80	65/64	357	66/65	80/80	69/68	361	67/66	80/80	70/69	362	71/70	80/80	75/74	366
		MED	64/63	80/80	67/66	381	68/67	80/80	72/70	385	69/68	80/80	73/72	386	73/72	80/80	77/76	390
		HIGH	67/66	80/80	70/69	392	71/70	80/80	75/74	396	Model not available due to high amperage draw.							
48TC*D14	460-3-60	STD	30	40	31	180	32	40	33	182	33	40	34	182	34	40	36	184
		MED	31	40	33	192	33	40	35	194	34	40	35	194	35	45	37	196
		HIGH	33	40	34	197	35	40	36	199	35	45	37	199	37	45	39	201
48TC*D14	575-3-60	STD	24	30	25	142	28	30	30	146	26	30	27	144	30	35	32	148
		MED	24	30	25	142	28	30	30	146	26	30	27	144	30	35	32	148
		HIGH	26	30	27	156	30	35	32	160	28	30	29	158	32	35	34	162
48TC*D16	208/230-3-60	STD	70/69	80/80	73/72	393	74/73	80/80	77/76	397	75/74	90/80	78/77	398	78/78	100/100	82/82	402
		MED	72/71	80/80	75/74	417	76/75	100/90	79/78	421	77/76	100/100	81/79	422	81/80	100/100	85/84	426
		HIGH	82	100	86	432	85	100	91	436	86	100	92	437	90	100	96	441
48TC*D16	460-3-60	STD	35	45	36	233	37	45	38	235	37	45	38	235	39	50	40	237
		MED	36	45	37	245	38	50	39	247	38	50	40	247	40	50	42	249
		HIGH	41	50	43	252	43	50	45	254	43	50	46	254	45	50	48	256
48TC*D16	575-3-60	STD	29	35	30	184	32	40	34	188	30	35	32	186	34	40	36	190
		MED	29	35	30	184	32	40	34	188	30	35	32	186	34	40	36	190
		HIGH	33	40	35	196	37	45	39	200	35	40	37	198	39	45	41	202

ELECTRICAL INFORMATION (UNITS PRODUCED ON OR AFTER JULY 30, 2012) cont.

Table 79 – UNIT WIRE/FUSE OR HACR BREAKER SIZING DATA FOR 2 STAGE COOLING WITH 2 SPEED INDOOR FAN MOTOR

UNIT	NOM. V-Ph-Hz	IFM TYPE	NO C.O. or UNPWR C.O.						w/ PWRD C.O.									
			NO PE.			w/ P.E. (pwrd fr/ unit)			NO PE.			w/ P.E. (pwrd fr/ unit)						
			MCA	MAX FUSE or HACR BRKR	DISC. SIZE FLA LRA	MCA	MAX FUSE or HACR BRKR	DISC. SIZE FLA LRA	MCA	MAX FUSE or HACR BRKR	DISC. SIZE FLA LRA	MCA	MAX FUSE or HACR BRKR	DISC. SIZE FLA LRA				
48TC*D08	208/ 230-3-60	STD	39.4/39.2	50/50	41/41	197	43.2/43.0	50/50	46/46	201	44.2/44.0	50/50	47/47	202	48.0/47.8	60/60	51/51	206
		MED	42.2/41.4	50/50	45/44	227	46.0/45.2	50/50	49/48	231	47.0/46.2	60/50	50/49	232	50.8/50.0	60/60	55/54	236
		HIGH	47.2/46.3	60/50	50/49	282	51.0/50.1	60/60	55/54	286	52.0/51.1	60/60	56/55	267	55.8/54.9	60/60	60/59	271
	460-3-60	STD	18.2	20	19	97	20.0	25	21	99	20.4	25	22	99	22.2	25	24	101
		MED	19.1	25	20	113	20.9	25	22	115	21.3	25	23	115	23.1	25	25	117
		HIGH	21.8	25	23	130	23.6	30	25	132	24.0	30	26	132	25.8	30	28	134
575-3-60	STD	13.5	15	14	79	17.3	20	19	83	15.2	20	16	81	19.0	25	21	85	
	MED	15.2	20	16	92	19.0	25	21	96	16.9	20	18	94	20.7	25	23	98	
	HIGH	17.4	20	18	106	21.2	25	23	110	19.1	25	20	108	22.9	25	24	112	
48TC*D09	208/ 230-3-60	STD	40.6/40.4	50/50	43/42	212	44.4/44.2	50/50	47/47	216	45.4/45.2	50/50	48/48	217	49.2/49.0	60/60	52/52	221
		MED	41.9/41.6	50/50	44/44	216	45.7/45.4	60/50	48/48	220	46.7/46.4	60/60	50/49	221	50.5/50.2	60/60	54/54	225
		HIGH	45.6/44.6	60/50	48/47	266	49.4/48.4	60/60	53/52	270	50.4/49.4	60/60	54/53	271	54.2/53.2	60/60	58/57	275
48TC*D12	460-3-60	STD	18.6	25	20	111	20.4	25	22	113	20.8	25	22	113	22.6	25	24	115
		MED	19.5	25	21	114	21.3	25	23	116	21.7	25	23	116	23.5	30	25	118
		HIGH	20.6	25	22	139	22.4	25	24	141	22.8	25	24	141	24.6	30	26	143
48TC*D12	575-3-60	STD	16.3	20	17	87	20.1	25	21	91	18.0	20	19	89	21.8	25	23	93
		MED	17.0	20	18	91	20.8	25	22	95	18.7	25	20	93	22.5	25	24	97
		HIGH	18.0	20	19	100	21.8	25	23	104	19.7	25	21	102	23.5	30	25	106
48TC*D12	208/ 230-3-60	STD	45.6/45.3	60/60	48/47	255	49.4/49.1	60/60	52/52	259	50.4/50.1	60/60	53/53	260	54.2/53.9	60/60	58/57	264
		MED	49.3/48.3	60/60	52/51	305	53.1/52.1	60/60	56/55	309	54.1/53.1	60/60	58/56	310	57.9/56.9	70/70	62/61	314
		HIGH	52.1/51.2	60/60	55/54	316	55.9/55.0	60/60	60/59	320	56.9/56.0	70/60	61/60	321	60.7/59.8	70/70	65/64	325
48TC*D12	460-3-60	STD	22.7	30	24	122	24.5	30	26	124	24.9	30	26	124	26.7	30	29	126
		MED	23.8	30	25	147	25.6	30	27	149	26.0	30	28	149	27.8	30	30	151
		HIGH	25.3	30	27	152	27.1	30	29	154	27.5	30	29	154	29.3	35	32	156
48TC*D12	575-3-60	STD	17.7	20	19	95	21.5	25	23	99	19.4	25	21	97	23.2	25	25	101
		MED	18.7	25	20	104	22.5	25	24	108	20.4	25	22	106	24.2	30	26	110
		HIGH	20.5	25	22	118	24.3	30	26	122	22.2	25	24	120	26.0	30	28	124

ELECTRICAL INFORMATION (UNITS PRODUCED ON OR AFTER JULY 30, 2012) cont.

Table 79 - UNIT WIRE/FUSE OR HACR BREAKER SIZING DATA FOR 2 STAGE COOLING WITH 2 SPEED INDOOR FAN MOTOR (cont.)

UNIT	NOM. V-Ph-Hz	IFM TYPE	NO C.O. or UNPWR C.O.						w/ PWRD C.O.									
			NO PE.			w/ PE. (pwrd fr/ unit)			NO PE.			w/ PE. (pwrd fr/ unit)						
			MCA	MAX FUSE or HACR BRKR	DISC. SIZE FLA LRA	MCA	MAX FUSE or HACR BRKR	DISC. SIZE FLA LRA	MCA	MAX FUSE or HACR BRKR	DISC. SIZE FLA LRA	MCA	MAX FUSE or HACR BRKR	DISC. SIZE FLA LRA				
48TC*D14	208/ 230-3-60	STD	61.8/61.0	80/80	65/64	357	65.6/64.8	80/80	69/68	361	66.6/65.8	80/80	70/69	362	70.4/69.6	80/80	75/74	366
		MED	64.0/63.0	80/80	67/66	381	67.8/66.8	80/80	72/70	385	68.8/67.8	80/80	73/72	386	72.6/71.6	80/80	77/76	390
		HIGH	66.8/65.9	80/80	70/69	392	70.6/69.7	80/80	75/74	396	Model not available due to high amperage draw.							
	460-3-60	STD	29.9	40	31	180	31.7	40	33	182	32.1	40	34	182	33.9	40	36	184
		MED	31.0	40	33	192	32.8	40	35	194	33.2	40	35	194	35.0	45	37	196
		HIGH	32.5	40	34	197	34.3	40	36	199	34.7	45	37	199	36.5	45	39	201
575-3-60	STD	24.0	30	25	142	27.8	30	30	146	25.7	30	27	144	29.5	35	32	148	
	MED	24.0	30	25	142	27.8	30	30	146	25.7	30	27	144	29.5	35	32	148	
	HIGH	25.7	30	27	156	29.5	35	32	160	27.4	30	29	158	31.2	35	34	162	
48TC*D16	208/ 230-3-60	STD	69.4/68.6	80/80	73/72	393	73.2/72.4	80/80	77/76	397	74.2/73.4	90/80	78/77	398	78.0/77.2	100/100	82/82	402
		MED	71.6/70.6	80/80	75/74	417	75.4/74.4	100/90	79/78	421	76.4/75.4	100/100	81/79	422	80.2/79.2	100/100	85/84	426
		HIGH	81.2	100	86	432	85.0	100	91	436	86.0	100	92	437	89.8	100	96	441
	460-3-60	STD	34.4	45	36	233	36.2	45	38	235	36.6	45	38	235	38.4	50	40	237
		MED	35.5	45	37	245	37.3	50	39	247	37.7	50	40	247	39.5	50	42	249
		HIGH	40.8	50	43	252	42.6	50	45	254	43.0	50	46	254	44.8	50	48	256
575-3-60	STD	28.2	35	30	184	32.0	40	34	188	29.9	35	32	186	33.7	40	36	190	
	MED	28.2	35	30	184	32.0	40	34	188	29.9	35	32	186	33.7	40	36	190	
		HIGH	32.7	40	35	196	36.5	45	39	200	34.4	40	37	198	38.2	45	41	202

ELECTRICAL DATA FOR UNITS PRODUCED PRIOR TO JULY 30, 2012

NOTE: Check the serial number of unit to verify production date.

To confirm the date of manufacture, locate the unit nameplate and check the first four digits of the Serial Number. If the number listed in the first 4 digits of the Serial Number is 3111 or lower, the unit was produced prior to July 30, 2012.

Position:	1	2	3	4	5	6	7	8	9	10
Example:	3	1	1	2	U	1	2	3	4	5

Week of manufacture (fiscal calendar)			Sequence number
Year of manufacture ("12" = 2012)		Manufacturing location	

C12562A



ELECTRICAL INFORMATION (UNITS PRODUCED PRIOR TO JULY 30, 2012)

Table 80 – 48TC04 SINGLE STAGE COOLING WITH SINGLE SPEED INDOOR FAN MOTOR 3 TONS**

V-Ph-Hz	VOLTAGE RANGE		COMP (ea)		OFM (ea)		IFM		
	MIN	MAX	RLA	LRA	WATTS	FLA	TYPE	EFF at Full Load	FLA
208-1-60	187	253	16.6	79	325	1.5	STD	70%	4.9
							MED	70%	4.9
230-1-60	187	253	16.6	79	325	1.5	STD	70%	4.9
							MED	70%	4.9
208-3-60	187	253	10.4	73	325	1.5	STD	70%	4.9
							MED	70%	4.9
							HIGH	80%	5.2
230-3-60	187	253	10.4	73	325	1.5	STD	70%	4.9
							MED	70%	4.9
							HIGH	80%	5.2
460-3-60	414	506	5.8	38	325	0.8	STD	70%	2.1
							MED	70%	2.1
							HIGH	80%	2.6
575-3-60	518	633	3.8	37	325	0.6	STD	71%	1.9
							MED	71%	1.9
							HIGH	80%	2.0

Table 81 – 48TC05 SINGLE STAGE COOLING WITH SINGLE SPEED INDOOR FAN MOTOR 4 TONS**

V-Ph-Hz	VOLTAGE RANGE		COMP (ea)		OFM (ea)		IFM		
	MIN	MAX	RLA	LRA	WATTS	FLA	TYPE	EFF at Full Load	FLA
208-1-60	187	253	21.8	117	325	1.5	STD	70%	4.9
							MED	78%	7.0
230-1-60	187	253	21.8	117	325	1.5	STD	70%	4.9
							MED	78%	7.0
208-3-60	187	253	13.7	83	325	1.5	STD	70%	4.9
							MED	70%	4.9
							HIGH	80%	5.2
230-3-60	187	253	13.7	83	325	1.5	STD	70%	4.9
							MED	70%	4.9
							HIGH	80%	5.2
460-3-60	414	506	6.2	41	325	0.8	STD	70%	2.1
							MED	70%	2.1
							HIGH	80%	2.6
575-3-60	518	633	4.8	37	325	0.6	STD	71%	1.9
							MED	71%	2.1
							HIGH	80%	2.0

Table 82 – 48TC*06 SINGLE STAGE COOLING WITH SINGLE SPEED INDOOR FAN MOTOR 5 TONS

V-Ph-Hz	VOLTAGE RANGE		COMP (ea)		OFM (ea)		IFM		
	MIN	MAX	RLA	LRA	WATTS	FLA	TYPE	EFF at Full Load	FLA
208-1-60	187	253	26.2	134	325	1.5	STD	70%	4.9
							MED	78%	7.0
230-1-60	187	253	26.2	134	325	1.5	STD	70%	4.9
							MED	78%	7.0
208-3-60	187	253	15.6	110	325	1.5	STD	70%	4.9
							MED	80%	5.2
							HIGH	81%	7.5
230-3-60	187	253	15.6	110	325	1.5	STD	70%	4.9
							MED	80%	5.2
							HIGH	81%	7.5
460-3-60	414	506	7.7	52	325	0.8	STD	70%	2.1
							MED	80%	2.6
							HIGH	81%	3.4
575-3-60	518	633	5.8	39	325	0.6	STD	71%	1.9
							MED	81%	2.0
							HIGH	81%	2.8

ELECTRICAL INFORMATION
(UNITS PRODUCED PRIOR TO JULY 30, 2012) cont.

Table 83 – 48TC07 SINGLE STAGE COOLING WITH SINGLE SPEED INDOOR FAN MOTOR 6 TONS**

V-Ph-Hz	VOLTAGE RANGE		COMP (ea)		OFM (ea)		IFM		
	MIN	MAX	RLA	LRA	WATTS	FLA	TYPE	EFF at Full Load	FLA
208-3-60	187	253	19.0	123	325	1.5	STD	80%	5.2
							MED	81%	7.5
							HIGH	81%	7.5
230-3-60	187	253	19.0	123	325	1.5	STD	80%	5.2
							MED	81%	7.5
							HIGH	81%	7.5
460-3-60	414	506	9.7	62	325	0.8	STD	80%	2.6
							MED	81%	3.4
							HIGH	81%	4.4
575-3-60	518	633	7.4	50	325	0.6	STD	80%	2.0
							MED	81%	2.8
							HIGH	81%	2.8

Table 84 – 48TC*A08 SINGLE STAGE COOLING WITH SINGLE SPEED INDOOR FAN MOTOR 7.5 TONS

V-Ph-Hz	VOLTAGE RANGE		COMP (ea)		OFM (ea)		IFM		
	MIN	MAX	RLA	LRA	WATTS	FLA	TYPE	EFF at Full Load	FLA
208-3-60	187	253	25.0	164	325	1.5	STD	80%	5.2
							MED	81%	7.5
							HIGH	81%	15.0
230-3-60	187	253	25.0	164	325	1.5	STD	80%	5.2
							MED	81%	7.5
							HIGH	81%	15.0
460-3-60	414	506	12.2	100	325	0.8	STD	80%	2.6
							MED	81%	3.4
							HIGH	81%	7.4
575-3-60	518	633	9.0	78	325	0.6	STD	80%	2.4
							MED	81%	2.8
							HIGH	81%	5.6

Table 85 – 48TC08 2-STAGE COOLING WITH SINGLE SPEED INDOOR FAN MOTOR 7.5 TONS**

V-Ph-Hz	VOLTAGE RANGE		COMP (Cir 1)		COMP (Cir 2)		OFM (ea)		IFM		
	MIN	MAX	RLA	LRA	RLA	LRA	WATTS	FLA	TYPE	EFF at Full Load	FLA
208-3-60	187	253	13.6	83	13.6	83	325	1.5	STD	80%	5.2
									MED	81%	7.5
									HIGH	81%	15.0
230-3-60	187	253	13.6	83	13.6	83	325	1.5	STD	80%	5.2
									MED	81%	7.5
									HIGH	81%	15.0
460-3-60	414	506	6.1	41	6.1	41	325	0.8	STD	80%	2.6
									MED	81%	3.4
									HIGH	81%	7.4
575-3-60	518	633	4.2	33	4.2	33	325	0.6	STD	80%	2.4
									MED	81%	2.8
									HIGH	81%	5.6

ELECTRICAL INFORMATION
(UNITS PRODUCED PRIOR TO JULY 30, 2012) cont.

Table 86 – 48TC08 2-STAGE COOLING WITH 2 SPEED INDOOR FAN MOTOR 7.5 TONS**

V-Ph-Hz	VOLTAGE RANGE		COMP 1		COMP 2		OFM (ea)		IFM		
	MIN	MAX	RLA	LRA	RLA	LRA	WATTS	FLA	TYPE	EFF at Full Load	FLA
208-3-60	187	253	13.6	83	13.6	83	325	1.5	STD	84%	5.8
							325	1.5	MED	85%	8.6
							325	1.5	HIGH	84%	13.6
230-3-60	187	253	13.6	83	13.6	83	325	1.5	STD	84%	5.6
							325	1.5	MED	85%	7.8
							325	1.5	HIGH	84%	12.7
460-3-60	414	506	6.1	41	6.1	41	325	0.8	STD	79%	2.9
							325	0.8	MED	85%	3.8
							325	0.8	HIGH	84%	6.4
575-3-60	518	633	4.2	33	4.2	33	325	0.6	STD	81%	2.8
							325	0.6	MED	84%	4.5
							325	0.6	HIGH	83%	6.2

Table 87 – 48TC09 SINGLE STAGE COOLING WITH SINGLE SPEED INDOOR FAN MOTOR 8.5 TONS**

V-Ph-Hz	VOLTAGE RANGE		COMP (ea)		OFM (ea)		IFM		
	MIN	MAX	RLA	LRA	WATTS	FLA	TYPE	EFF at Full Load	FLA
208-3-60	187	253	29.5	195	325	1.5	STD	80%	5.2
							MED	80%	5.2
							HIGH	80%	10.0
230-3-60	187	253	29.5	195	325	1.5	STD	80%	5.2
							MED	80%	5.2
							HIGH	80%	10.0
460-3-60	414	506	14.7	95	325	0.8	STD	80%	2.6
							MED	80%	2.6
							HIGH	80%	4.4
575-3-60	518	633	12.2	80	325	0.6	STD	80%	2.4
							MED	80%	2.0
							HIGH	81%	2.8

Table 88 – 48TC09 2-STAGE COOLING WITH SINGLE SPEED INDOOR FAN MOTOR 8.5 TONS**

V-Ph-Hz	VOLTAGE RANGE		COMP (Cir 1)		COMP (Cir 2)		OFM (ea)		IFM		
	MIN	MAX	RLA	LRA	RLA	LRA	WATTS	FLA	TYPE	EFF at Full Load	FLA
208-3-60	187	253	14.5	98	13.7	83	325	1.5	STD	80%	5.2
									MED	80%	5.2
									HIGH	80%	10.0
230-3-60	187	253	14.5	98	13.7	83	325	1.5	STD	80%	5.2
									MED	80%	5.2
									HIGH	80%	10.0
460-3-60	414	506	6.3	55	6.2	41	325	0.8	STD	80%	2.6
									MED	80%	2.6
									HIGH	80%	4.4
575-3-60	518	633	6.0	41	4.8	33	325	0.6	STD	80%	2.4
									MED	80%	2.0
									HIGH	81%	2.8

ELECTRICAL INFORMATION
(UNITS PRODUCED PRIOR TO JULY 30, 2012) cont.

Table 89 – 48TC09 2-STAGE COOLING WITH 2 SPEED INDOOR FAN MOTOR 8.5 TONS**

V-Ph-Hz	VOLTAGE RANGE		COMP 1		COMP 2		OFM (ea)		IFM		
	MIN	MAX	RLA	LRA	RLA	LRA	WATTS	FLA	TYPE	EFF at Full Load	FLA
208-3-60	187	253	14.5	98	13.7	83	325	1.5	STD	84%	5.8
							325	1.5	MED	77%	7.1
							325	1.5	HIGH	82%	10.8
230-3-60	187	253	14.5	98	13.7	83	325	1.5	STD	84%	5.6
							325	1.5	MED	77%	6.8
							325	1.5	HIGH	82%	9.8
460-3-60	414	506	6.3	55	6.2	41	325	0.8	STD	79%	2.9
							325	0.8	MED	77%	3.8
							325	0.8	HIGH	82%	4.9
575-3-60	518	633	6.0	41	4.8	33	325	0.6	STD	81%	2.8
							325	0.6	MED	80%	3.5
							325	0.6	HIGH	84%	4.5

Table 90 – 48TC12 SINGLE STAGE COOLING WITH SINGLE SPEED INDOOR FAN MOTOR 10 TONS**

V-Ph-Hz	VOLTAGE RANGE		COMP (ea)		OFM (ea)		IFM		
	MIN	MAX	RLA	LRA	WATTS	FLA	TYPE	EFF at Full Load	FLA
208-3-60	187	253	30.1	225	325	1.5	STD	80%	5.2
							MED	81%	10.0
							HIGH	81%	15.0
230-3-60	187	253	30.1	225	325	1.5	STD	80%	5.2
							MED	81%	10.0
							HIGH	81%	15.0
460-3-60	414	506	16.7	114	325	0.8	STD	80%	2.6
							MED	81%	4.4
							HIGH	81%	7.4
575-3-60	518	633	12.2	80	325	0.6	STD	80%	2.0
							MED	81%	2.8
							HIGH	81%	5.6

Table 91 – 48TC12 2-STAGE COOLING WITH SINGLE SPEED INDOOR FAN MOTOR 10 TONS**

V-Ph-Hz	VOLTAGE RANGE		COMP (Cir 1)		COMP (Cir 2)		OFM (ea)		IFM		
	MIN	MAX	RLA	LRA	RLA	LRA	WATTS	FLA	TYPE	EFF at Full Load	FLA
208-3-60	187	253	15.6	110	15.9	110	325	1.5	STD	80%	5.2
									MED	81%	10.0
									HIGH	81%	15.0
230-3-60	187	253	15.6	110	15.9	110	325	1.5	STD	80%	5.2
									MED	81%	10.0
									HIGH	81%	15.0
460-3-60	414	506	7.7	52	7.7	52	325	0.8	STD	80%	2.6
									MED	81%	4.4
									HIGH	81%	7.4
575-3-60	518	633	5.8	39	5.7	39	325	0.6	STD	80%	2.0
									MED	81%	2.8
									HIGH	81%	5.6

ELECTRICAL INFORMATION
(UNITS PRODUCED PRIOR TO JULY 30, 2012) cont.

Table 92 – 48TC12 2-STAGE COOLING WITH 2 SPEED INDOOR FAN MOTOR 10 TONS**

V-Ph-Hz	VOLTAGE RANGE		COMP 1		COMP 2		OFM (ea)		IFM		
	MIN	MAX	RLA	LRA	RLA	LRA	WATTS	FLA	TYPE	EFF at Full Load	FLA
208-3-60	187	253	15.6	110	15.9	110	325	1.5	STD	77%	7.1
							325	1.5	MED	82%	10.8
							325	1.5	HIGH	84%	13.6
230-3-60	187	253	15.6	110	15.9	110	325	1.5	STD	77%	6.8
							325	1.5	MED	82%	9.8
							325	1.5	HIGH	84%	12.7
460-3-60	414	506	7.7	52	7.7	52	325	0.8	STD	77%	3.8
							325	0.8	MED	82%	4.9
							325	0.8	HIGH	84%	6.4
575-3-60	518	633	5.8	39	5.7	39	325	0.6	STD	80%	3.5
							325	0.6	MED	84%	4.5
							325	0.6	HIGH	83%	6.2

Table 93 – 48TC14 2-STAGE COOLING WITH SINGLE SPEED INDOOR FAN MOTOR 12.5 TONS**

V-Ph-Hz	VOLTAGE RANGE		COMP (Cir 1)		COMP (Cir 2)		OFM (ea)		IFM		
	MIN	MAX	RLA	LRA	RLA	LRA	WATTS	FLA	TYPE	EFF at Full Load	FLA
208-3-60	187	253	19.0	123	22.4	149	1288	6.2	STD	81%	7.5
									MED	81%	10.0
									HIGH	81%	15.0
230-3-60	187	253	19.0	123	22.4	149	1288	6.2	STD	81%	7.5
									MED	81%	10.0
									HIGH	81%	15.0
460-3-60	414	506	9.7	62	10.6	75	1288	3.1	STD	81%	3.4
									MED	81%	4.4
									HIGH	81%	7.4
575-3-60	518	633	7.4	50	7.7	54	1288	2.5	STD	81%	2.8
									MED	81%	2.8
									HIGH	81%	5.6

Table 94 – 48TC14 2-STAGE COOLING WITH 2 SPEED INDOOR FAN MOTOR 12.5 TONS**

V-Ph-Hz	VOLTAGE RANGE		COMP 1		COMP 2		OFM (ea)		IFM		
	MIN	MAX	RLA	LRA	RLA	LRA	WATTS	FLA	TYPE	EFF at Full Load	FLA
208-3-60	187	253	19.0	123	22.4	149	1070	6.2	STD	85%	8.6
							1070	6.2	MED	82%	10.8
							1070	6.2	HIGH	84%	13.6
230-3-60	187	253	19.0	123	22.4	149	1070	6.2	STD	85%	7.8
							1070	6.2	MED	82%	9.8
							1070	6.2	HIGH	84%	12.7
460-3-60	414	506	9.7	62	10.6	75	1070	3.1	STD	85%	3.8
							1070	3.1	MED	82%	4.9
							1070	3.1	HIGH	84%	6.4
575-3-60	518	633	7.4	50	7.7	54	1070	2.5	STD	84%	4.5
							1070	2.5	MED	84%	4.5
							1070	2.5	HIGH	83%	6.2

ELECTRICAL INFORMATION
(UNITS PRODUCED PRIOR TO JULY 30, 2012) cont.

Table 95 – 48TC16 2-STAGE COOLING WITH SINGLE SPEED INDOOR FAN MOTOR 15 TONS**

V-Ph-Hz	VOLTAGE RANGE		COMP (Cir 1)		COMP (Cir 2)		OFM (ea)		IFM		
	MIN	MAX	RLA	LRA	RLA	LRA	WATTS	FLA	TYPE	EFF at Full Load	FLA
208-3-60	187	253	25.0	164	25.0	164	1288	1.5	STD	81%	7.5
									MED	81%	10.0
									HIGH	89.5%	20.4
230-3-60	187	253	25.0	164	25.0	164	1288	1.5	STD	81%	7.5
									MED	81%	10.0
									HIGH	89.5%	20.4
460-3-60	414	506	12.2	100	12.8	100	1288	0.8	STD	81%	3.4
									MED	81%	4.4
									HIGH	89.5%	10.2
575-3-60	518	633	9.8	78	9.6	78	1288	0.6	STD	81%	2.8
									MED	81%	2.8
									HIGH	89.5%	9.0

Table 96 – 48TC16 2-STAGE COOLING WITH 2 SPEED INDOOR FAN MOTOR 15 TONS**

V-Ph-Hz	VOLTAGE RANGE		COMP 1		COMP 2		OFM (ea)		IFM		
	MIN	MAX	RLA	LRA	RLA	LRA	WATTS	FLA	TYPE	EFF at Full Load	FLA
208-3-60	187	253	25.0	164	25.0	164	280	1.5	STD	85%	8.6
							280	1.5	MED	82%	10.8
							280	1.5	HIGH	90%	20.4
230-3-60	187	253	25.0	164	25.0	164	280	1.5	STD	85%	7.8
							280	1.5	MED	82%	9.8
							280	1.5	HIGH	90%	20.4
460-3-60	414	506	12.2	100	12.8	100	280	0.8	STD	85%	3.8
							280	0.8	MED	82%	4.9
							280	0.8	HIGH	90%	10.2
575-3-60	518	633	9.8	78	9.6	78	280	0.6	STD	84%	4.5
							280	0.6	MED	84%	4.5
							280	0.6	HIGH	94%	9.0

**ELECTRICAL INFORMATION
(UNITS PRODUCED PRIOR TO JULY 30, 2012) cont.**

Table 97 – UNIT WIRE/FUSE OR HACR BREAKER SIZING DATA

UNIT	NOM. V-Ph-Hz	IFM TYPE	NO C.O. or UNPWR C.O.						w/ PWRD C.O.									
			NO PE.			w/ P.E. (pwrdr fr/ unit)			NO PE.			w/ P.E. (pwrdr fr/ unit)						
			MCA	MAX FUSE or HACR BRKR	DISC. SIZE FLA LRA	MCA	MAX FUSE or HACR BRKR	DISC. SIZE FLA LRA	MCA	MAX FUSE or HACR BRKR	DISC. SIZE FLA LRA	MCA	MAX FUSE or HACR BRKR	DISC. SIZE FLA LRA				
48TC*A04	208/230-1-60	STD	27.2	40	26	95	29.1	45	29	97	32.0	45	32	100	33.9	50	34	102
		MED	27.2	40	26	95	29.1	45	29	97	32.0	45	32	100	33.9	50	34	102
	208/230-3-60	STD	19.4	25	19	89	21.3	30	22	91	24.2	30	25	94	26.1	30	27	96
		MED	19.4	25	19	89	21.3	30	22	91	24.2	30	25	94	26.1	30	27	96
	460-3-60	HIGH	19.7	30	20	107	21.6	30	22	109	24.5	30	25	112	26.4	30	27	114
		STD	10.2	15	10	46	11.2	15	11	47	12.4	15	13	48	13.4	15	14	49
		MED	10.2	15	10	46	11.2	15	11	47	12.4	15	13	48	13.4	15	14	49
		HIGH	10.7	15	11	55	11.7	15	12	56	12.9	15	13	57	13.9	20	14	58
	575-3-60	STD	7.3	15	7	44	9.2	15	9	46	9.0	15	9	46	10.9	15	11	48
		MED	7.3	15	7	44	9.2	15	9	46	9.0	15	9	46	10.9	15	11	48
		HIGH	7.4	15	7	50	9.3	15	10	52	9.1	15	9	52	11.0	15	12	54
		STD	33.7	50	32	133	35.6	50	35	135	38.5	60	38	138	40.4	60	40	140
MED		33.7	50	32	133	35.6	50	35	135	38.5	60	38	138	40.4	60	40	140	
STD		23.5	30	23	99	25.4	30	25	101	28.3	40	29	104	30.2	40	31	106	
48TC*A05	208/230-1-60	MED	23.5	30	23	99	25.4	30	25	101	28.3	40	29	104	30.2	40	31	106
		HIGH	23.8	30	23	117	25.7	30	26	119	28.6	40	29	122	30.5	40	31	124
	460-3-60	STD	10.7	15	10	49	11.7	15	12	50	12.9	15	13	51	13.9	20	14	52
		MED	10.7	15	10	49	11.7	15	12	50	12.9	15	13	51	13.9	20	14	52
	575-3-60	HIGH	11.2	15	11	58	12.2	15	12	59	13.4	15	14	60	14.4	20	15	61
		STD	8.5	15	8	40	10.4	15	11	42	10.2	15	10	42	12.1	15	13	44
575-3-60	MED	8.5	15	8	40	10.4	15	11	42	10.2	15	10	42	12.1	15	13	44	
	HIGH	8.6	15	9	46	10.5	15	11	48	10.3	15	10	48	12.2	15	13	50	

**ELECTRICAL INFORMATION
(UNITS PRODUCED PRIOR TO JULY 30, 2012) cont.**

Table 97 - UNIT WIRE/FUSE OR HACR BREAKER SIZING DATA (cont)

UNIT	NOM. V-Ph-Hz	IFM TYPE	NO C.O. or UNPWR C.O.						w/ PWRD C.O.									
			NO PE.			w/ PE. (pwrd fr/ unit)			NO PE.			w/ PE. (pwrd fr/ unit)						
			MCA	MAX FUSE or HACR BRKR	DISC. SIZE FLA LRA	MCA	MAX FUSE or HACR BRKR	DISC. SIZE FLA LRA	MCA	MAX FUSE or HACR BRKR	DISC. SIZE FLA LRA	MCA	MAX FUSE or HACR BRKR	DISC. SIZE FLA LRA				
48TC*A06	208/230-1-60	STD	39.2	60	37	150	41.1	60	40	152	44.0	60	43	155	45.9	60	45	157
		MED	41.3	60	40	175	43.2	60	42	177	46.1	60	45	180	48.0	60	48	182
		STD	25.9	30	25	126	27.8	40	27	128	30.7	45	31	131	32.6	45	33	133
	208/230-3-60	MED	26.2	40	26	144	28.1	40	28	146	31.0	45	31	149	32.9	45	33	151
		HIGH	28.5	40	28	170	30.4	45	30	172	33.3	45	34	175	35.2	50	36	177
		STD	12.5	20	12	60	13.5	20	13	61	14.7	20	15	62	15.7	20	16	63
	460-3-60	MED	13.0	20	13	69	14.0	20	14	70	15.2	20	15	71	16.2	20	16	72
		HIGH	13.8	20	14	82	14.8	20	15	83	16.0	20	16	84	17.0	20	17	85
		STD	9.8	15	10	46	11.7	15	12	48	11.5	15	12	48	13.4	15	14	50
		MED	9.9	15	10	52	11.8	15	12	54	11.6	15	12	54	13.5	15	14	56
		HIGH	10.7	15	11	63	12.6	15	13	65	12.4	15	13	65	14.3	20	15	67
		STD	30.5	45	30	157	32.4	50	32	159	35.3	50	35	162	37.2	50	37	164
48TC*A07	208/230-3-60	MED	32.8	50	32	183	34.7	50	34	185	37.6	50	38	188	39.5	50	40	190
		HIGH	32.8	50	32	183	34.7	50	34	185	37.6	50	38	188	39.5	50	40	190
		STD	15.5	25	15	79	16.5	25	16	80	17.7	25	18	81	18.7	25	19	82
	460-3-60	MED	16.3	25	16	92	17.3	25	17	93	18.5	25	19	94	19.5	25	20	95
		HIGH	17.3	25	17	101	18.3	25	18	102	19.5	25	20	103	20.5	30	21	104
		STD	11.9	15	12	63	13.8	20	14	65	13.6	20	13	65	15.5	20	16	67
575-3-60	MED	12.7	20	12	74	14.6	20	15	76	14.4	20	14	76	16.3	20	17	78	
	HIGH	12.7	20	12	74	14.6	20	15	76	14.4	20	14	76	16.3	20	17	78	
	STD	39.5	60	38	191	43.3	60	43	195	44.3	60	44	196	48.1	60	48	200	
48TC*A08	208/230-3-60	MED	41.8	60	41	228	45.6	60	45	232	46.6	60	46	233	50.4	60	51	237
		HIGH	49.3	60	49	254	53.1	60	54	258	54.1	70	55	259	57.9	80	59	263
		STD	19.5	30	19	113	21.3	30	21	115	21.7	30	21	115	23.5	30	23	117
	460-3-60	MED	20.3	30	20	132	22.1	30	22	134	22.5	30	22	134	24.3	30	24	136
		HIGH	24.3	30	24	145	26.1	30	26	147	26.5	30	27	147	28.3	40	29	149
		STD	14.9	20	14	89	18.7	25	19	93	16.6	25	16	91	20.4	25	21	95
575-3-60	MED	15.3	20	15	104	19.1	25	19	108	17.0	25	17	106	20.8	25	21	110	
	HIGH	18.1	25	18	118	21.9	30	23	122	19.8	25	20	120	23.6	30	24	124	

ELECTRICAL INFORMATION (UNITS PRODUCED PRIOR TO JULY 30, 2012) cont.

Table 97 - UNIT WIRE/FUSE OR HACR BREAKER SIZING DATA (cont.)

UNIT	NOM. V-Ph-Hz	IFM TYPE	NO P.E.			NO C.O. or UNPWR C.O.			NO P.E.			w/ PWRD C.O.					
			MAX FUSE or HACR BRKR	DISC. SIZE		MCA	MAX FUSE or HACR BRKR	DISC. SIZE		MCA	MAX FUSE or HACR BRKR	DISC. SIZE		MCA			
				FLA	LRA			FLA	LRA			FLA	LRA				
48TC*A09	208/230-3-60	STD	60	43	222	48.9	60	48	226	49.9	60	49	227	53.7	80	53	231
		MED	60	43	233	48.9	60	48	237	49.9	60	49	238	53.7	80	53	242
		HIGH	60	49	276	53.7	80	53	280	54.7	80	54	281	58.5	80	59	285
	460-3-60	STD	30	22	108	24.4	30	24	110	24.8	30	24	110	26.6	40	26	112
		MED	30	22	114	24.4	30	24	116	24.8	30	24	116	26.6	40	26	118
		HIGH	30	24	136	26.2	30	26	138	26.6	40	26	138	28.4	40	28	140
575-3-60	STD	30	18	91	22.7	30	23	95	20.6	30	20	93	24.4	30	24	97	
	MED	30	18	95	22.3	30	22	99	20.2	30	20	97	24.0	30	24	101	
	HIGH	30	19	106	23.1	30	23	110	21.0	30	21	108	24.8	30	25	112	
48TC*A12	208/230-3-60	STD	60	44	263	49.6	60	48	267	50.6	60	50	268	54.4	80	54	272
		MED	60	50	306	54.4	80	54	310	55.4	80	55	311	59.2	80	59	315
		HIGH	80	55	315	59.4	80	60	319	60.4	80	61	320	64.2	80	65	324
	460-3-60	STD	30	24	133	26.9	40	26	135	27.3	40	27	135	29.1	45	29	137
		MED	40	26	155	28.7	45	28	157	29.1	45	29	157	30.9	45	31	159
		HIGH	45	30	159	31.7	45	32	161	32.1	45	32	161	33.9	50	34	163
575-3-60	STD	30	18	95	22.3	30	22	99	20.2	30	20	97	24.0	30	24	101	
	MED	30	19	106	23.1	30	23	110	21.0	30	21	108	24.8	30	25	112	
	HIGH	30	22	120	25.9	30	26	124	23.8	30	24	122	27.6	35	28	126	

Example: Supply voltage is 230-3-60



- LEGEND:**
- BRKR Circuit breaker
 - CO Convenience outlet
 - DISC Disconnect
 - FLA Full load amps
 - IFM Indoor fan motor
 - LRA Locked rotor amps
 - MCA Minimum circuit amps
 - MOCPP MAX FUSE or HACR Breaker
 - PE Power exhaust
 - PWRD CO Powered convenient outlet
 - UNPWR CO Unpowered convenient outlet

1. In compliance with NEC requirements for multimotor and combination load equipment (refer to NEC Articles 430 and 440), the overcurrent protective device for the unit shall be fuse or HACR breaker. Canadian units may be fuse or circuit breaker.

2. Unbalanced 3-Phase Supply Voltage

Never operate a motor where a phase imbalance in supply voltage is greater than 2%. Use the following formula to determine the percentage of voltage imbalance.

$$\% \text{ Voltage Imbalance} = 100 \times \frac{\text{max voltage deviation from average voltage}}{\text{average voltage}}$$

$$\text{Average Voltage} = \frac{(224 + 231 + 226)}{3} = \frac{681}{3} = 227$$

Determine maximum deviation from average voltage.

$$(AB) 227 - 224 = 3 \text{ v}$$

$$(BC) 231 - 227 = 4 \text{ v}$$

$$(AC) 227 - 226 = 1 \text{ v}$$

Maximum deviation is 4 v.

Determine percent of voltage imbalance.

$$\% \text{ Voltage Imbalance} = 100 \times \frac{4}{227} = 1.76\%$$

This amount of phase imbalance is satisfactory as it is below the maximum allowable 2%.

IMPORTANT: If the supply voltage phase imbalance is more than 2%, contact your local electric utility company immediately.

**ELECTRICAL INFORMATION
(UNITS PRODUCED PRIOR TO JULY 30, 2012) cont.**

Table 98 – UNIT WIRE/FUSE OR HACR BREAKER SIZING DATA WITH 2 SPEED INDOOR FAN MOTOR

UNIT	NOM. V-Ph-Hz	IFM TYPE	NO C.O. or UNPWR C.O.						w/ PWRD C.O.								
			NO PE.			w/ P.E. (pwrdr fr/ unit)			NO PE.			w/ PWRD C.O.					
			MAX FUSE or HACR BRKR	FLA	LRA	MCA	MAX FUSE or HACR BRKR	FLA	LRA	MCA	MAX FUSE or HACR BRKR	FLA	LRA	MCA	MAX FUSE or HACR BRKR	FLA	LRA
48TC*D08	208/230-3-60	STD	50	41	193	42.6	50	45	197	43.6	50	46	198	47.4	60	51	202
		MED	50	43	230	44.9	50	48	234	45.9	50	49	235	49.7	60	53	239
		HIGH	60	52	256	52.8	60	56	260	53.8	60	58	261	57.6	70	62	265
	460-3-60	STD	20	19	95	19.7	25	21	97	20.1	25	21	97	21.9	25	23	99
		MED	25	20	114	20.5	25	22	116	20.9	25	22	116	22.7	25	24	118
		HIGH	30	24	127	24.9	30	26	129	25.3	30	27	129	27.1	30	29	131
575-3-60	STD	15	14	77	16.9	20	18	81	14.8	20	16	79	18.6	20	20	83	
	MED	15	14	92	17.3	20	19	96	15.2	20	16	94	19.0	25	21	98	
	HIGH	20	17	106	20.4	25	22	110	18.3	20	19	108	22.1	25	24	112	
48TC*D09	208/230-3-60	STD	50	42	208	43.8	50	46	212	44.8	50	47	213	48.6	60	52	217
		MED	50	42	219	43.8	50	46	223	44.8	50	47	224	48.6	60	52	228
		HIGH	50	47	262	48.6	60	52	266	49.6	60	53	267	53.4	60	57	271
	460-3-60	STD	20	19	109	20.1	25	21	111	20.5	25	22	111	22.3	25	24	113
		MED	20	19	115	20.1	25	21	117	20.5	25	22	117	22.3	25	24	119
		HIGH	25	21	137	21.9	25	23	139	22.3	25	24	139	24.1	30	26	141
575-3-60	STD	20	17	85	19.7	25	21	89	17.6	20	19	87	21.4	25	23	91	
	MED	20	16	89	19.3	25	20	93	17.2	20	18	91	21.0	25	22	95	
	HIGH	20	17	100	20.1	25	21	104	18.0	20	19	102	21.8	25	23	106	
48TC*D12	208/230-3-60	STD	50	46	258	47.5	60	50	262	48.5	60	51	263	52.3	60	56	267
		MED	60	51	301	52.3	60	56	305	53.3	60	57	306	57.1	70	61	310
		HIGH	60	57	310	57.3	70	61	314	58.3	70	62	315	62.1	70	67	319
	460-3-60	STD	25	23	123	23.3	30	25	125	23.7	30	25	125	25.5	30	27	127
		MED	30	25	145	25.1	30	27	147	25.5	30	27	147	27.3	30	29	149
		HIGH	30	28	149	28.1	35	30	151	28.5	35	31	151	30.3	35	33	153
575-3-60	STD	20	17	93	20.0	25	21	97	17.9	20	19	95	21.7	25	23	99	
	MED	20	18	104	20.8	25	22	108	18.7	25	20	106	22.5	25	24	110	
	HIGH	25	21	118	23.6	30	25	122	21.5	25	23	120	25.3	30	27	124	



**ELECTRICAL INFORMATION
(UNITS PRODUCED PRIOR TO JULY 30, 2012) cont.**

Table 98 - UNIT WIRE/FUSE OR HACR BREAKER SIZING DATA WITH 2 SPEED INDOOR FAN MOTOR (cont.)

UNIT	NOM. V-Ph-Hz	IFM TYPE	NO C.O. or UNPWR C.O.						w/ PWRD C.O.									
			NO PE.			w/ P.E. (pwrd fr/ unit)			NO PE.			w/ PWRD C.O.						
			MCA	MAX FUSE or HACR BRKR	DISC. SIZE FLA LRA	MCA	MAX FUSE or HACR BRKR	DISC. SIZE FLA LRA	MCA	MAX FUSE or HACR BRKR	DISC. SIZE FLA LRA	MCA	MAX FUSE or HACR BRKR	DISC. SIZE FLA LRA				
48TC*D14	208/230-3-60	STD	60.7	80	63	360	64.5	80	68	364	65.5	80	69	365	69.3	80	73	369
		MED	63.2	80	66	377	67.0	80	71	381	68.0	80	72	382	71.8	80	76	386
		HIGH	68.2	80	72	386	72.0	80	76	390								
48TC*D14	460-3-60	STD	29.5	40	31	181	31.3	40	33	183	31.7	40	33	183	33.5	40	35	185
		MED	30.5	40	32	190	32.3	40	34	192	32.7	40	35	192	34.5	45	37	194
		HIGH	33.5	40	35	194	35.3	45	37	196	35.7	45	38	196	37.5	45	40	198
48TC*D16	575-3-60	STD	22.3	30	23	142	26.1	30	28	146	24.0	30	25	144	27.8	30	30	148
		MED	22.3	30	23	142	26.1	30	28	146	24.0	30	25	144	27.8	30	30	148
		HIGH	25.1	30	27	156	28.9	35	31	160	26.8	30	29	158	30.6	35	33	162
48TC*D16	208/230-3-60	STD	68.3	80	71	396	72.1	80	76	400	73.1	80	77	401	76.9	100	81	405
		MED	70.8	80	74	413	74.6	90	79	417	75.6	100	80	418	79.4	100	84	422
		HIGH	81.2	100	86	432	85.0	100	91	436	86.0	100	92	437	89.8	100	96	441
48TC*D16	460-3-60	STD	34.0	45	35	234	35.8	45	37	236	36.2	45	38	236	38.0	50	40	238
		MED	35.0	45	37	243	36.8	45	39	245	37.2	50	39	245	39.0	50	41	247
		HIGH	40.8	50	43	252	42.6	50	45	254	43.0	50	46	254	44.8	50	48	256
48TC*D16	575-3-60	STD	26.5	30	28	184	30.3	40	32	188	28.2	35	30	186	32.0	40	34	190
		MED	26.5	30	28	184	30.3	40	32	188	28.2	35	30	186	32.0	40	34	190
		HIGH	32.7	40	35	196	36.5	45	39	200	34.4	40	37	198	38.2	45	41	202



**ELECTRICAL INFORMATION
(UNITS PRODUCED PRIOR TO JULY 30, 2012) cont.**

Table 99 – UNIT WIRE/FUSE OR HACR BREAKER SIZING DATA FOR 2 STAGE COOLING WITH 2 SPEED INDOOR FAN MOTOR

UNIT	NOM. V-Ph-Hz	IFM TYPE	NO C.O. or UNPWR C.O.						w/ PWRD C.O.									
			NO PE.			w/ P.E. (pwrd fr/ unit)			NO PE.			w/ P.E. (pwrd fr/ unit)						
			MCA	MAX FUSE or HACR BRKR	DISC. SIZE FLA LRA	MCA	MAX FUSE or HACR BRKR	DISC. SIZE FLA LRA	MCA	MAX FUSE or HACR BRKR	DISC. SIZE FLA LRA	MCA	MAX FUSE or HACR BRKR	DISC. SIZE FLA LRA				
48TC*D08	208/ 230-3-60	STD	39.4/39.2	50/50	41/41	197	43.2/43.0	50/50	46/46	201	44.2/44.0	50/50	47/47	202	48.0/47.8	60/60	51/51	206
		MED	42.2/41.4	50/50	45/44	227	46.0/45.2	50/50	49/48	231	47.0/46.2	60/50	50/49	232	50.8/50.0	60/60	55/54	236
		HIGH	47.2/46.3	60/50	50/49	282	51.0/50.1	60/60	55/54	286	52.0/51.1	60/60	56/55	267	55.8/54.9	60/60	60/59	271
	460-3-60	STD	18.2	20	19	97	20.0	25	21	99	20.4	25	22	99	22.2	25	24	101
		MED	19.1	25	20	113	20.9	25	22	115	21.3	25	23	115	23.1	25	25	117
		HIGH	21.8	25	23	130	23.6	30	25	132	24.0	30	26	132	25.8	30	28	134
575-3-60	STD	13.5	15	14	79	17.3	20	19	83	15.2	20	16	81	19.0	25	21	85	
	MED	15.2	20	16	92	19.0	25	21	96	16.9	20	18	94	20.7	25	23	98	
	HIGH	17.4	20	18	106	21.2	25	23	110	19.1	25	20	108	22.9	25	24	112	
48TC*D09	208/ 230-3-60	STD	40.6/40.4	50/50	43/42	212	44.4/44.2	50/50	47/47	216	45.4/45.2	50/50	48/48	217	49.2/49.0	60/60	52/52	221
		MED	41.9/41.6	50/50	44/44	216	45.7/45.4	60/50	48/48	220	46.7/46.4	60/60	50/49	221	50.5/50.2	60/60	54/54	225
		HIGH	45.6/44.6	60/50	48/47	266	49.4/48.4	60/60	53/52	270	50.4/49.4	60/60	54/53	271	54.2/53.2	60/60	58/57	275
48TC*D12	460-3-60	STD	18.6	25	20	111	20.4	25	22	113	20.8	25	22	113	22.6	25	24	115
		MED	19.5	25	21	114	21.3	25	23	116	21.7	25	23	116	23.5	30	25	118
		HIGH	20.6	25	22	139	22.4	25	24	141	22.8	25	24	141	24.6	30	26	143
48TC*D12	575-3-60	STD	16.3	20	17	87	20.1	25	21	91	18.0	20	19	89	21.8	25	23	93
		MED	17.0	20	18	91	20.8	25	22	95	18.7	25	20	93	22.5	25	24	97
		HIGH	18.0	20	19	100	21.8	25	23	104	19.7	25	21	102	23.5	30	25	106
48TC*D12	208/ 230-3-60	STD	45.6/45.3	60/60	48/47	255	49.4/49.1	60/60	52/52	259	50.4/50.1	60/60	53/53	260	54.2/53.9	60/60	58/57	264
		MED	49.3/48.3	60/60	52/51	305	53.1/52.1	60/60	56/55	309	54.1/53.1	60/60	58/56	310	57.9/56.9	70/70	62/61	314
		HIGH	52.1/51.2	60/60	55/54	316	55.9/55.0	60/60	60/59	320	56.9/56.0	70/60	61/60	321	60.7/59.8	70/70	65/64	325
48TC*D12	460-3-60	STD	22.7	30	24	122	24.5	30	26	124	24.9	30	26	124	26.7	30	29	126
		MED	23.8	30	25	147	25.6	30	27	149	26.0	30	28	149	27.8	30	30	151
		HIGH	25.3	30	27	152	27.1	30	29	154	27.5	30	29	154	29.3	35	32	156
48TC*D12	575-3-60	STD	17.7	20	19	95	21.5	25	23	99	19.4	25	21	97	23.2	25	25	101
		MED	18.7	25	20	104	22.5	25	24	108	20.4	25	22	106	24.2	30	26	110
		HIGH	20.5	25	22	118	24.3	30	26	122	22.2	25	24	120	26.0	30	28	124

**ELECTRICAL INFORMATION
(UNITS PRODUCED PRIOR TO JULY 30, 2012) cont.**

Table 99 - UNIT WIRE/FUSE OR HACR BREAKER SIZING DATA FOR 2 STAGE COOLING WITH 2 SPEED INDOOR FAN MOTOR (cont.)

UNIT	NOM. V-Ph-Hz	IFM TYPE	NO C.O. or UNPWR C.O.						w/ PWRD C.O.									
			NO PE.			w/ PE. (pwrd fr/ unit)			NO PE.			w/ PE. (pwrd fr/ unit)						
			MCA	MAX FUSE or HACR BRKR	DISC. SIZE FLA LRA	MCA	MAX FUSE or HACR BRKR	DISC. SIZE FLA LRA	MCA	MAX FUSE or HACR BRKR	DISC. SIZE FLA LRA	MCA	MAX FUSE or HACR BRKR	DISC. SIZE FLA LRA				
48TC*D14	208/ 230-3-60	STD	61.8/61.0	80/80	65/64	357	65.6/64.8	80/80	69/68	361	66.6/65.8	80/80	70/69	362	70.4/69.6	80/80	75/74	366
		MED	64.0/63.0	80/80	67/66	381	67.8/66.8	80/80	72/70	385	68.8/67.8	80/80	73/72	386	72.6/71.6	80/80	77/76	390
		HIGH	66.8/65.9	80/80	70/69	392	70.6/69.7	80/80	75/74	396	Model not available due to high amperage draw.							
	575-3-60	STD	29.9	40	31	180	31.7	40	33	182	32.1	40	34	182	33.9	40	36	184
		MED	31.0	40	33	192	32.8	40	35	194	33.2	40	35	194	35.0	45	37	196
		HIGH	32.5	40	34	197	34.3	40	36	199	34.7	45	37	199	36.5	45	39	201
		STD	24.0	30	25	142	27.8	30	30	146	25.7	30	27	144	29.5	35	32	148
		MED	24.0	30	25	142	27.8	30	30	146	25.7	30	27	144	29.5	35	32	148
		HIGH	25.7	30	27	156	29.5	35	32	160	27.4	30	29	158	31.2	35	34	162
48TC*D16	208/ 230-3-60	STD	69.4/68.6	80/80	73/72	393	73.2/72.4	80/80	77/76	397	74.2/73.4	90/80	78/77	398	78.0/77.2	100/100	82/82	402
		MED	71.6/70.6	80/80	75/74	417	75.4/74.4	100/90	79/78	421	76.4/75.4	100/100	81/79	422	80.2/79.2	100/100	85/84	426
		HIGH	81.2	100	86	432	85.0	100	91	436	86.0	100	92	437	89.8	100	96	441
	575-3-60	STD	34.4	45	36	233	36.2	45	38	235	36.6	45	38	235	38.4	50	40	237
		MED	35.5	45	37	245	37.3	50	39	247	37.7	50	40	247	39.5	50	42	249
		HIGH	40.8	50	43	252	42.6	50	45	254	43.0	50	46	254	44.8	50	48	256
		STD	28.2	35	30	184	32.0	40	34	188	29.9	35	32	186	33.7	40	36	190
		MED	28.2	35	30	184	32.0	40	34	188	29.9	35	32	186	33.7	40	36	190
		HIGH	32.7	40	35	196	36.5	45	39	200	34.4	40	37	198	38.2	45	41	202

SEQUENCE OF OPERATION

General

The sequence below describes the sequence of operation for an electromechanical unit with and without a factory installed EconoMi\$er IV and X (called “economizer” in this sequence). For information regarding a direct digital controller, see the start-up, operations, and troubleshooting manual for the applicable controller.

Electromechanical units with no economizer

Cooling (Single speed indoor fan motor) —

When the thermostat calls for cooling, terminals G and Y1 are energized. As a result, the indoor fan contactor (IFC) and the compressor contactor (C1) are energized, causing the indoor fan motor (IFM), compressor #1, and outdoor fan to start. If the unit has 2 stages of cooling, the thermostat will additionally energize Y2. The Y2 signal will energize compressor contactor #2 (C2), causing compressor #2 to start. Regardless of the number of stages, the outdoor fan motor runs continuously while unit is cooling. When SAV system is utilized, indoor fan motor runs at design CFM (full speed) during the heating operation.

Cooling (2-speed indoor fan motor) —

Per ASHRAE 90.1 2010 standard section 6.4.3.10.b, during the first stage of cooling operation the VFD will adjust the fan motor to provide 2/3rd of the total cfm established for the unit. When a call for the second stage of cooling is required, the VFD will allow the total cfm for the unit established (100%).

Heating (Single or 2-speed indoor fan motor) —

NOTE: WeatherMaker (48TC) units have either 1 or 2 stages of gas heat. When SAV system is utilized, indoor fan motor runs at design cfm (full speed) during the heating operation.

When the thermostat calls for heating, power is sent to W on the Integrated Gas Controller (IGC) board. An LED (light-emitting diode) on the IGC board turns on and remains on during normal operation. A check is made to ensure that the rollout switch and limit switch are closed. If the check was successful, the induced-draft motor is energized, and when its speed is satisfactory, as proven by the “hall effect” sensor, the ignition activation period begins. The burners will ignite within 5 seconds. If the burners do not light, there is a 22-second delay before another 5-second attempt. This sequence is repeated for 15 minutes or until the burners light. If, after the 15 minutes, the burners still have not lit, heating is locked out. To reset the control, break 24-v power to the thermostat.

When ignition occurs, the IGC board will continue to monitor the condition of the rollout switch, the limit switches, the “hall effect” sensor, as well as the flame sensor. 45 seconds after ignition occurs, assuming the unit is controlled through a room thermostat set for fan auto, the indoor fan motor will energize (and the outdoor air dampers will open to their minimum position). If, for

some reason, the over-temperature limit opens prior to the start of the indoor fan blower, the unit will shorten the 45-second delay to 5 seconds less than the time from initiation of heat to when the limit tripped. Gas will not be interrupted to the burners and heating will continue. Once the fan-on delay has been modified, it will not change back to 45 seconds until power is reset to the control.

On units with 2 stages of heat, when additional heat is required, W2 closes and initiates power to the second stage of the main gas valve. When the thermostat is satisfied, W1 and W2 open and the gas valve closes, interrupting the flow of gas to the main burners.

If the call for W1 lasted less than 1 minute, the heating cycle will not terminate until 1 minute after W1 became active. If the unit is controlled through a room thermostat set for fan auto, the indoor fan motor will continue to operate for an additional 45 seconds then stop. If the over-temperature limit opens after the indoor motor is stopped, but within 10 minutes of W1 becoming inactive, on the next cycle the time will be extended by 15 seconds. The maximum delay is 3 minutes. Once modified, the fan off delay will not change back to 45 seconds unless power is reset to the control. A LED indicator is provided on the IGC to monitor operation.

Electromechanical units with an economizer

Cooling —

When free cooling is not available, the compressors will be controlled by the zone thermostat. When free cooling is available, the outdoor air damper is modulated by the EconoMi\$er IV and X control to provide a 50°F (10°C) to 55°F (13°C) mixed air temperature into the zone. As the mixed air temperature fluctuates above 55°F (13°C) or below 50°F (10°C) dampers will be modulated (open or close) to bring the mixed air temperature back within control. If mechanical cooling is utilized with free cooling, the outdoor air damper will maintain its current position at the time the compressor is started. If the increase in cooling capacity causes the mixed air temperature to drop below 45°F (7°C), then the outdoor air damper position will be decreased to the minimum position. If the mixed air temperature continues to fall, the outdoor air damper will close. Control returns to normal once the mixed air temperature rises above 48°F (9°C). The power exhaust fans will be energized and de-energized, if installed, as the outdoor air damper opens and closes.

If field installed accessory CO₂ sensors are connected to the EconoMi\$er IV and X control, a demand controlled ventilation strategy will begin to operate. As the CO₂ level in the zone increases above the CO₂ setpoint, the minimum position of the damper will be increased proportionally. As the CO₂ level decreases because of the increase in fresh air, the outdoor air damper will be proportionally closed. For EconoMi\$er IV and X operation, there must be a thermostat call for the fan (G).

SEQUENCE OF OPERATION (cont.)

If the unit is occupied and the fan is on, the damper will operate at minimum position. Otherwise, the damper will be closed.

If field installed accessory CO₂ sensors are connected to the EconoMi\$er IV and X control, a demand controlled ventilation strategy will begin to operate. As the CO₂ level in the zone increases above the CO₂ setpoint, the minimum position of the damper will be increased proportionally. As the CO₂ level decreases because of the increase in fresh air, the outdoor air damper will be proportionally closed. For EconoMi\$er IV and X operation, there must be a thermostat call for the fan (G). If the unit is occupied and the fan is on, the damper will operate at minimum position. Otherwise, the damper will be closed.

When the EconoMi\$er IV and X control is in the occupied mode and a call for cooling exists (Y1 on the thermostat), the control will first check for indoor fan operation. If the fan is not on, then cooling will not be activated. If the fan is on, then the control will open the EconoMi\$er IV and X damper to the minimum position.

On the initial power to the EconoMi\$er IV and X control, it will take the damper up to 2 1/2 minutes before it begins to position itself. After the initial power-up, further changes in damper position can take up to 30 seconds to initiate. Damper movement from full closed to full open (or vice versa) will take between 1 1/2 and 2 1/2 minutes. If free cooling can be used as determined from the appropriate changeover command (switch, dry bulb, enthalpy curve, differential dry bulb, or differential enthalpy), then the control will modulate the dampers open to maintain the mixed air temperature setpoint at 50°F (10°C) to 55°F (13°C). If there is a further demand for cooling (cooling second stage - Y2 is energized), then the control will bring on compressor stage 1 to maintain the mixed air temperature setpoint. The EconoMi\$er IV and X damper will be open at maximum position.

2-Speed Note: When operating in ventilation mode only, the indoor fan motor will automatically adjust to 2/3rd of the total cfm established.

Heating

The sequence of operation for the heating is the same as an electromechanical unit with no economizer. The only difference is how the economizer acts. The economizer will stay at the Economizer Minimum Position while the evaporator fan is operating. The outdoor air damper is closed when the indoor fan is not operating.

Optional Humidi-MiZer Dehumidification System

Units with the factory equipped Humidi-MiZer option are capable of providing multiple modes of improved dehumidification as a variation of the normal cooling cycle. The Humidi-MiZer option includes additional valves in the liquid line and discharge line of each refrigerant circuit, a small reheat condenser coil downstream of the evaporator, and Motormaster variable-speed control of some or all outdoor fans. Operation of the revised refrigerant circuit for each mode is described below.

The Humidi-MiZer system provides three sub-modes of operation: Cool, Reheat1, and Reheat2.

Cool mode - provides a normal ratio of Sensible and Latent Cooling effect from the evaporator coil.

Reheat1 - provides increased Latent Cooling while slightly reducing the Sensible Cooling effect.

Reheat2 - provides normal Latent Cooling but with null or minimum Sensible Cooling effect delivered to the space.

The Reheat1 and Reheat2 modes are available when the unit is not in a Heating mode and when the Low Ambient Lockout switch is closed.

The following diagrams depict piping for Single Stage cooling units.

SEQUENCE OF OPERATION (cont.)

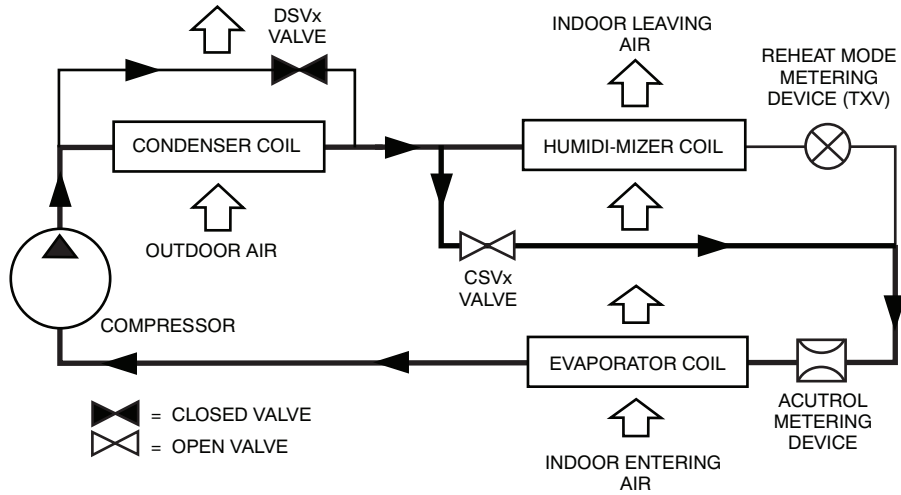

C12647

Normal Cooling Mode - Humidi-MiZer System with Single Stage Cooling

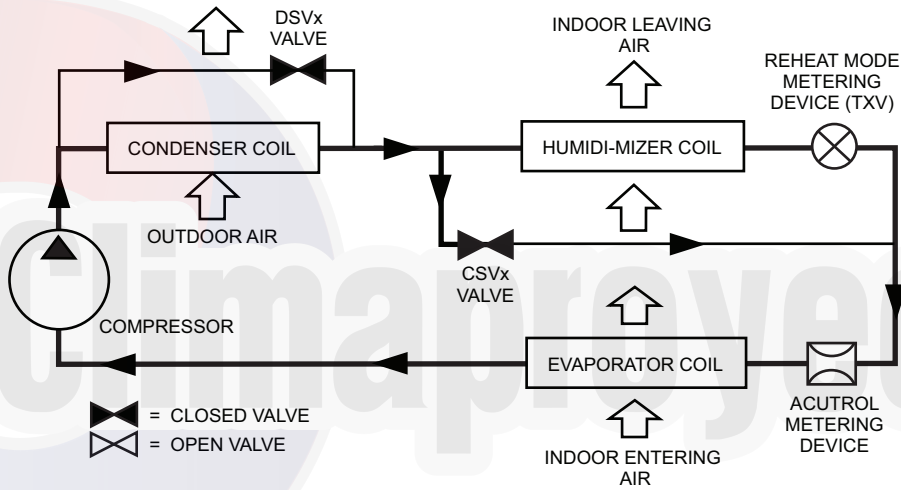

C12648

Subcooling Mode (Reheat 1) - Humidi-MiZer System with Single Stage Cooling

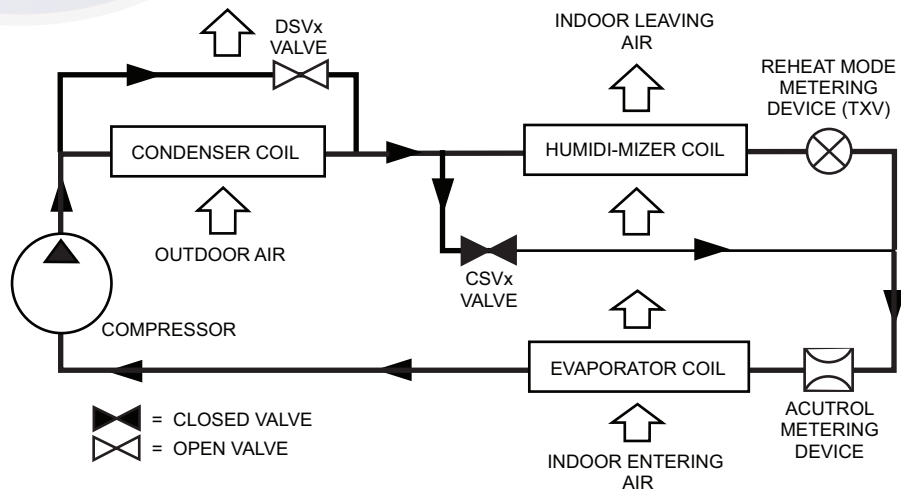

C12649

Hot Gas Reheat Mode (Reheat 2) - Humidi-MiZer System with Single Stage Cooling

Gas Heat/Electric Cooling Packaged Rooftop

HVAC Guide Specifications

Size Range: 3 to 15 Nominal Tons



<u>Section</u>	<u>Description</u>
----------------	--------------------

23 06 80	Schedules for Decentralized HVAC Equipment
-----------------	---

- | | |
|----------------|---|
| 23 06 80.13 | Decentralized Unitary HVAC Equipment Schedule |
| 23 06 80.13.A. | Rooftop unit schedule |
| 1. | Schedule is per the project specification requirements. |

23 07 16	HVAC Equipment Insulation
-----------------	----------------------------------

- | | |
|----------------|---|
| 23 07 16.13 | Decentralized, Rooftop Units: |
| 23 07 16.13.A. | Evaporator fan compartment: |
| 1. | Interior cabinet surfaces shall be insulated with a minimum 1/2-in. thick, minimum 1 1/2 lb density, flexible fiberglass insulation bonded with a phenolic binder, neoprene coated on the air side. |
| 2. | Insulation and adhesive shall meet NFPA 90A requirements for flame spread and smoke generation. |
| 23 07 16.13.B. | Gas heat compartment: |
| 1. | Aluminum foil-faced fiberglass insulation shall be used. |
| 2. | Insulation and adhesive shall meet NFPA 90A requirements for flame spread and smoke generation. |

23 09 13	Instrumentation and Control Devices for HVAC
-----------------	---

- | | |
|----------------|---|
| 23 09 13.23 | Sensors and Transmitters |
| 23 09 13.23.A. | Thermostats |
| 1. | Thermostat must |
| a. | energize both "W" and "G" when calling for heat. |
| b. | have capability to energize 2 different stages of cooling, and 2 different stages of heating. |
| c. | include capability for occupancy scheduling. |

23 09 23	Direct-digital Control system for HVAC
-----------------	---

- | | |
|----------------|---|
| 23 09 23.13 | Decentralized, Rooftop Units: |
| 23 09 23.13.A. | PremierLink controller |
| 1. | Shall be ASHRAE 62-2001 compliant. |
| 2. | Shall accept 18-32 VAC input power. |
| 3. | Shall have an operating temperature range from -40°F (-40°C) to 158°F (70°C), 10% - 95% RH (non-condensing). |
| 4. | Shall include an integrated economizer controller to support an economizer with 4 to 20 mA actuator input and no microprocessor controller. |
| 5. | Controller shall accept the following inputs: space temperature, setpoint adjustment, outdoor air temperature, indoor air quality, outdoor air quality, indoor relative humidity, compressor lock-out, fire shutdown, enthalpy, fan status, remote time clock/door switch. |
| 6. | Shall accept a CO ₂ sensor in the conditioned space, and be Demand Control Ventilation (DCV) ready. |
| 7. | Shall provide the following outputs: economizer, fan, cooling stage 1, cooling stage 2, heat stage 1, heat stage 2, heat stage 3/ exhaust/ reversing valve/ dehumidify/ occupied. |
| 8. | Unit shall provide surge protection for the controller through a circuit breaker. |
| 9. | Shall be Internet capable, and communicate at a Baud rate of 38.4K or faster |
| 10. | Shall have an LED display independently showing the status of activity on the communication bus, and processor operation. |
| 11. | Shall include an EIA-485 protocol communication port, an access port for connection of either a computer or a Carrier technician tool, an EIA-485 port for network communication to intelligent space sensors and displays, and a port to connect an optional LonWorks plug-in communications card. |
| 12. | Shall have built-in Carrier Comfort Network™ (CCN) protocol, and be compatible with other CCN devices, including ComfortLink™ and ComfortVIEW™ controllers. |
| 13. | Shall have built-in support for Carrier technician tool. |

14. Software upgrades will be accomplished by local download. Software upgrades through chip replacements are not allowed.
15. Shall be shock resistant in all planes to 5G peak, 11ms during operation, and 100G peak, 11ms during storage.
16. Shall be vibration resistant in all planes to 1.5G @ 20-300 Hz.
17. Shall support a bus length of 4000 ft (1219m) max, 60 devices per 1000 ft (305m) section, and 1 RS-485 repeater per 1000 ft (305m) sections.

23 09 23.13.B. RTU Open - Open protocol, direct digital controller:

1. Shall be ASHRAE 62-2001 compliant.
2. Shall accept 18-30VAC, 50-60Hz, and consumer 15VA or less power.
3. Shall have an operating temperature range from -40°F (-40°C) to 130°F (54°C), 10% - 90% RH (non-condensing).
4. Shall include built-in protocol for BACNET (MS/TP and PTP modes), Modbus (RTU and ASCII), Johnson N2 and LonWorks. LonWorks Echelon processor required for all Lon applications shall be contained in separate communication board.
5. Shall allow access of up to 62 network variables (SNVT). Shall be compatible with all open controllers.
6. Baud rate Controller shall be selectable using a dipswitch.
7. Shall have an LED display independently showing the status of serial communication, running, errors, power, all digital outputs, and all analog inputs.
8. Shall accept the following inputs: space temperature, setpoint adjustment, outdoor air temperature, indoor air quality, outdoor air quality, compressor lock-out, fire shutdown, enthalpy switch, and fan status/filter status/humidity/ remote occupancy.
9. Shall provide the following outputs: economizer, variable frequency drive, fan, cooling stage 1, cooling stage 2, heat stage 1, heat stage 2, exhaust reversing valve/high fan speed.
10. Shall have built-in surge protection circuitry through solid state polyswitches. Polyswitches shall be used on incoming power and network connections. Polyswitches will return to normal when the "trip" condition clears.
11. Shall have a battery back-up capable of a minimum of 10,000 hours of data and time clock retention during power outages.
12. Shall have built-in support for Carrier technician tool.
13. Shall include an EIA-485 protocol communication port, an access port for connection of either a computer or a Carrier technician tool, an EIA-485 port for network communication to intelligent space sensors and displays, and a port to connect an optional LonWorks communications card.
14. Software upgrades will be accomplished by either local or remote download. No software upgrades through chip replacements are allowed.

23 09 33 Electric and Electronic Control System for HVAC

23 09 33.13 Decentralized, Rooftop Units:

23 09 33.13.A. General:

1. Shall be complete with self-contained low-voltage control circuit protected by a resettable circuit breaker on the 24-v transformer side. Transformer shall have 75VA capability.
2. Shall utilize color-coded wiring.
3. Shall include a central control terminal board to conveniently and safely provide connection points for vital control functions such as: smoke detectors, phase monitor, gas controller, economizer, thermostat, DDC control options, and low and high pressure switches.
4. The heat exchanger shall be controlled by an integrated gas controller (IGC) microprocessor. See heat exchanger section of this specification.
5. Unit shall include a minimum of one 8-pin screw terminal connection board for connection of control wiring.

23 09 33.23.B. Safeties:

1. Compressor over-temperature, over-current. High internal pressure differential.
2. Low pressure switch.
 - a. Units with 2 compressors shall have different sized connectors for the circuit 1 and circuit 2 low and high pressure switches. They shall physically prevent the cross-wiring of the safety switches between circuits 1 and 2.
 - b. Low pressure switch shall use different color wire than the high pressure switch. The purpose is to assist the installer and service technician to correctly wire and or troubleshoot the rooftop unit.

3. High pressure switch.
 - a. Units with 2 compressors shall have different sized connectors for the circuit 1 and circuit 2 low and high pressure switches. They shall physically prevent the cross-wiring of the safety switches between circuits 1 and 2.
 - b. High pressure switch shall use different color wire than the low pressure switch. The purpose is to assist the installer and service technician to correctly wire and or troubleshoot the rooftop unit.
4. Automatic reset, motor thermal overload protector.
5. Heating section shall be provided with the following minimum protections:
 - a. High temperature limit switches.
 - b. Induced draft motor speed sensor.
 - c. Flame rollout switch.
 - d. Flame proving controls.

23 09 93 Sequence of Operations for HVAC Controls

23 09 93.13 Decentralized, Rooftop Units:

23 09 93.13 INSERT SEQUENCE OF OPERATION

23 40 13 Panel Air Filters

23 40 13.13 Decentralized, Rooftop Units:

23 40 13.13.A. Standard filter section

1. Shall consist of factory installed, low velocity, disposable 2-in. thick fiberglass filters of commercially available sizes.
2. Unit shall use only one filter size. Multiple sizes are not acceptable.
3. Filters shall be accessible through an access panel with “no-tool” removal as described in the unit cabinet section of this specification (23 81 19.13.H).

23 81 19 Self-Contained Air Conditioners

23 81 19.13 Small-Capacity Self-Contained Air Conditioners (48TC**04-16)

23 81 19.13.A. General

1. Outdoor, rooftop mounted, electrically controlled, heating and cooling unit utilizing a fully hermetic scroll compressor(s) for cooling duty and gas combustion for heating duty.
2. Factory assembled, single-piece heating and cooling rooftop unit. Contained within the unit enclosure shall be all factory wiring, piping, controls, and special features required prior to field start-up.
3. Unit shall use environmentally sound, Puron refrigerant.
4. Unit shall be installed in accordance with the manufacturer’s instructions.
5. Unit must be selected and installed in compliance with local, state, and federal codes.

23 81 19.13.B. Quality Assurance

1. Unit meets ASHRAE 90.1 minimum efficiency requirements.
2. Unit shall be rated in accordance with AHRI Standards 210/240 and 340/360.
3. Unit shall be designed to conform to ASHRAE 15, 2001.
4. Unit shall be UL-tested and certified in accordance with ANSI Z21.47 Standards and UL-listed and certified under Canadian standards as a total package for safety requirements.
5. Insulation and adhesive shall meet NFPA 90A requirements for flame spread and smoke generation.
6. Unit casing shall be capable of withstanding 500-hour salt spray exposure per ASTM B117 (scribed specimen).
7. Unit casing shall be capable of withstanding Federal Test Method Standard No. 141 (Method 6061) 5000-hour salt spray.
8. Unit shall be designed in accordance with ISO 9001, and shall be manufactured in a facility registered by ISO 9001.
9. Roof curb shall be designed to conform to NRCA Standards.
10. Unit shall be subjected to a completely automated run test on the assembly line. The data for each unit will be stored at the factory, and must be available upon request.
11. Unit shall be designed in accordance with UL Standard 1995, including tested to withstand rain.
12. Unit shall be constructed to prevent intrusion of snow and tested to prevent snow intrusion into the control box up to 40 mph.
13. Unit shake tested to assurance level 1, ASTM D4169 to ensure shipping reliability.
14. High Efficient Motors listed shall meet section 313 of the Energy Independence and Security Act of 2007 (EISA 2007)

23 81 19.13.C. Delivery, Storage, and Handling

1. Unit shall be stored and handled per manufacturer's recommendations.
2. Lifted by crane requires either shipping top panel or spreader bars.
3. Unit shall only be stored or positioned in the upright position.

23 81 19.13.E. Project Conditions

1. As specified in the contract.

23 81 19.13.F. Operating Characteristics

1. Unit shall be capable of starting and running at 115°F (46°C) ambient outdoor temperature, meeting maximum load criteria of AHRI Standard 210/240 or 340/360 at ± 10% voltage.
2. Compressor with standard controls shall be capable of operation down to 40°F (4°C), ambient outdoor temperatures. Accessory winter start kit is necessary if mechanically cooling at ambient temperatures down to 25°F (-4°C).
3. Unit shall discharge supply air vertically or horizontally as shown on contract drawings.
4. Unit shall be factory configured for vertical supply & return configurations.
5. Unit shall be field convertible from vertical to horizontal airflow on all models. No special kit required on 04-14 models. Supply duct kit required for 16 size model only.
6. Unit shall be capable of mixed operation: vertical supply with horizontal return or horizontal supply with vertical return.

23 81 19.13.G. Electrical Requirements

1. Main power supply voltage, phase, and frequency must match those required by the manufacturer.

23 81 19.13.H. Unit Cabinet

1. Unit cabinet shall be constructed of galvanized steel, and shall be bonderized and coated with a prepainted baked enamel finish on all externally exposed surfaces.
2. Unit cabinet exterior paint shall be: film thickness, (dry) 0.003 inches minimum, gloss (per ASTM D523, 60°F / 16°C): 60, Hardness: H-2H Pencil hardness.
3. Evaporator fan compartment interior cabinet insulation shall conform to AHRI Standards 210/240 or 340/360 minimum exterior sweat criteria. Interior surfaces shall be insulated with a minimum 1/2-in. thick, 1 lb density, flexible fiberglass insulation, neoprene coated on the air side. Aluminum foil-faced fiberglass insulation shall be used in the gas heat compartment.
4. Base of unit shall have a minimum of four locations for thru-the-base gas and electrical connections (factory installed or field installed), standard.
5. Base Rail
 - a. Unit shall have base rails on a minimum of 2 sides.
 - b. Holes shall be provided in the base rails for rigging shackles to facilitate maneuvering and overhead rigging.
 - c. Holes shall be provided in the base rail for moving the rooftop by fork truck.
 - d. Base rail shall be a minimum of 16 gauge thickness.
6. Condensate pan and connections:
 - a. Shall be a sloped condensate drain pan made of a non-corrosive material.
 - b. Shall comply with ASHRAE Standard 62.
 - c. Shall use a 3/4" -14 NPT drain connection, possible either through the bottom or side of the drain pan. Connection shall be made per manufacturer's recommendations.
7. Top panel:
 - a. Shall be a single piece top panel on 04 thru 12 sizes, two piece on 14 and 16 sizes.
8. Gas Connections:
 - a. All gas piping connecting to unit gas valve shall enter the unit cabinet at a single location on side of unit (horizontal plane).
 - b. Thru-the-base capability
 - (1.) Standard unit shall have a thru-the-base gas-line location using a raised, embossed portion of the unit basepan.
 - (2.) Optional, factory approved, water-tight connection method must be used for thru-the-base gas connections.
 - (3.) No basepan penetration, other than those authorized by the manufacturer, is permitted.
9. Electrical Connections
 - a. All unit power wiring shall enter unit cabinet at a single, factory prepared, knockout location.

- b. Thru-the-base capability.
 - (1.) Standard unit shall have a thru-the-base electrical location(s) using a raised, embossed portion of the unit basepan.
 - (2.) Optional, factory approved, water-tight connection method must be used for thru-the-base electrical connections.
 - (3.) No basepan penetration, other than those authorized by the manufacturer, is permitted.
- 10. Component access panels (standard)
 - a. Cabinet panels shall be easily removable for servicing.
 - b. Unit shall have one factory installed, tool-less, removable, filter access panel.
 - c. Panels covering control box, indoor fan, indoor fan motor, gas components (where applicable), and compressors shall have molded composite handles.
 - d. Handles shall be UV modified, composite. They shall be permanently attached, and recessed into the panel.
 - e. Screws on the vertical portion of all removable access panel shall engage into heat resistant, molded composite collars.
 - f. Collars shall be removable and easily replaceable using manufacturer recommended parts.

23 81 19.13.I. Gas Heat

1. General

- a. Heat exchanger shall be an induced draft design. Positive pressure heat exchanger designs shall not be allowed.
- b. Shall incorporate a direct-spark ignition system and redundant main gas valve.
- c. Gas supply pressure at the inlet to the rooftop unit gas valve must match that required by the manufacturer.
- 2. The heat exchanger shall be controlled by an integrated gas controller (IGC) microprocessor.
 - a. IGC board shall notify users of fault using an LED (light-emitting diode).
 - b. The LED shall be visible without removing the control box access panel.
 - c. IGC board shall contain algorithms that modify evaporator fan operation to prevent future cycling on high temperature limit switch.
 - d. Unit shall be equipped with anti-cycle protection with one short cycle on unit flame rollout switch or 4 continuous short cycles on the high temperature limit switch. Fault indication shall be made using an LED.

3. Standard Heat Exchanger construction

- a. Heat exchanger shall be of the tubular-section type constructed of a minimum of 20-gauge steel coated with a nominal 1.2 mil aluminum-silicone alloy for corrosion resistance.
- b. Burners shall be of the in-shot type constructed of aluminum-coated steel.
- c. Burners shall incorporate orifices for rated heat output up to 2000 ft (610m) elevation. Additional accessory kits may be required for applications above 2000 ft (610m) elevation, depending on local gas supply conditions.
- d. Each heat exchanger tube shall contain multiple dimples for increased heating effectiveness.

4. Optional Stainless Steel Heat Exchanger construction

- a. Use energy saving, direct-spark ignition system.
- b. Use a redundant main gas valve.
- c. Burners shall be of the in-shot type constructed of aluminum-coated steel.
- d. All gas piping shall enter the unit cabinet at a single location on side of unit (horizontal plane).
- e. The optional stainless steel heat exchanger shall be of the tubular-section type, constructed of a minimum of 20-gauge type 409 stainless steel.
- f. Type 409 stainless steel shall be used in heat exchanger tubes and vestibule plate.
- g. Complete stainless steel heat exchanger allows for greater application flexibility.

5. Optional Low NO_x Heat Exchanger construction

- a. Low NO_x reduction shall be provided to reduce nitrous oxide emissions to meet California's Air Quality Management District (SCAQMD) low-NO_x emissions requirement of 40 nanograms per joule or less.
- b. Primary tubes and vestibule plates on low NO_x units shall be 409 stainless steel. Other components shall be aluminized steel.

6. Induced draft combustion motor and blower

- a. Shall be a direct-drive, single inlet, forward-curved centrifugal type.
- b. Shall be made from steel with a corrosion-resistant finish.
- c. Shall have permanently lubricated sealed bearings.
- d. Shall have inherent thermal overload protection.

- e. Shall have an automatic reset feature.

23 81 19.13.J. Coils

1. Standard Aluminum Fin - Copper Tube Coils:
 - a. Standard evaporator and condenser coils shall have aluminum lanced plate fins mechanically bonded to seamless internally grooved copper tubes with all joints brazed.
 - b. Evaporator coils shall be leak tested to 150 psig, pressure tested to 450 psig, and qualified to UL 1995 burst test at 1775 psig.
 - c. Condenser coils shall be leak tested to 150 psig, pressure tested to 650 psig, and qualified to UL 1995 burst test at 1980 psig.
2. Optional Pre-coated aluminum-fin condenser coils (3 Phase Models Only):
 - a. Shall have a durable epoxy-phenolic coating to provide protection in mildly corrosive coastal environments.
 - b. Coating shall be applied to the aluminum fin stock prior to the fin stamping process to create an inert barrier between the aluminum fin and copper tube.
 - c. Epoxy-phenolic barrier shall minimize galvanic action between dissimilar metals.
3. Optional Copper-fin evaporator and condenser coils (3 Phase Models Only):
 - a. Shall be constructed of copper fins mechanically bonded to copper tubes and copper tube sheets.
 - b. Galvanized steel tube sheets shall not be acceptable.
 - c. A polymer strip shall prevent coil assembly from contacting the sheet metal coil pan to minimize potential for galvanic corrosion between coil and pan.
4. Optional E-coated aluminum-fin evaporator and condenser coils (3 Phase Models Only):
 - a. Shall have a flexible epoxy polymer coating uniformly applied to all coil surface areas without material bridging between fins.
 - b. Coating process shall ensure complete coil encapsulation of tubes, fins and headers.
 - c. Color shall be high gloss black with gloss per ASTM D523-89.
 - d. Uniform dry film thickness from 0.8 to 1.2 mil on all surface areas including fin edges.
 - e. Superior hardness characteristics of 2H per ASTM D3363-92A and cross-hatch adhesion of 4B-5B per ASTM D3359-93.
 - f. Impact resistance shall be up to 160 in.-lb (ASTM D2794-93).
 - g. Humidity and water immersion resistance shall be up to minimum 1000 and 250 hours respectively (ASTM D2247-92 and ASTM D870-92).
 - h. Corrosion durability shall be confirmed through testing to be no less than 1000 hours salt spray per ASTM B117-90.
5. Standard All Aluminum Novation Coils:
 - a. Standard condenser coils shall have all aluminum NOVATION Heat Exchanger Technology design consisting of aluminum multi port flat tube design and aluminum fin. Coils shall be a furnace brazed design and contain epoxy lined shrink wrap on all aluminum to copper connections.
 - b. Condenser coils shall be leak tested to 150 psig, pressure tested to 650 psig, and qualified to UL 1995 burst test at 1980 psig.
6. Optional E-coated aluminum-fin, aluminum tube condenser coils:
 - a. Shall have a flexible epoxy polymer coating uniformly applied to all coil external surface areas without material bridging between fins or louvers.
 - b. Coating process shall ensure complete coil encapsulation, including all exposed fin edges.
 - c. E-coat thickness of 0.8 to 1.2 mil with top coat having a uniform dry film thickness from 1.0 to 2.0 mil on all external coil surface areas, including fin edges, shall be provided.
 - d. Shall have superior hardness characteristics of 2H per ASTM D3363-00 and cross-hatch adhesion of 4B-5B per ASTM D3359-02.
 - e. Shall have superior impact resistance with no cracking, chipping or peeling per NSF/ANSI 51-2002 Method 10.2.

23 81 19.13.K. Refrigerant Components

1. Refrigerant circuit shall include the following control, safety, and maintenance features:
 - a. Fixed orifice metering system shall prevent mal-distribution of two-phase refrigerant by including multiple fixed orifice devices in each refrigeration circuit. Each orifice is to be optimized to the coil circuit it serves.
 - b. Refrigerant filter drier - Solid core design.
 - c. Service gauge connections on suction and discharge lines.
 - d. Pressure gauge access through a specially designed access port in the top panel of the unit.

2. There shall be gauge line access port in the skin of the rooftop, covered by a black, removable plug.
 - a. The plug shall be easy to remove and replace.
 - b. When the plug is removed, the gauge access port shall enable maintenance personnel to route their pressure gauge lines.
 - c. This gauge access port shall facilitate correct and accurate condenser pressure readings by enabling the reading with the compressor access panel on.
 - d. The plug shall be made of a leak proof, UV-resistant, composite material.
3. Compressors
 - a. Unit shall use fully hermetic, scroll compressor for each independent refrigeration circuit.
 - b. Compressor motors shall be cooled by refrigerant gas passing through motor windings.
 - c. Compressors shall be internally protected from high discharge temperature conditions.
 - d. Compressors shall be protected from an over-temperature and over-amperage conditions by an internal, motor overload device.
 - e. Compressor shall be factory mounted on rubber grommets.
 - f. Compressor motors shall have internal line break thermal, current overload and high pressure differential protection.
 - g. Crankcase heaters shall not be required for normal operating range, unless required by compressor manufacturer due to refrigerant charge limits.

23 81 19.13.L. Filter Section

1. Filters access is specified in the unit cabinet section of this specification.
2. Filters shall be held in place by a pivoting filter tray, facilitating easy removal and installation.
3. Shall consist of factory installed, low velocity, throw-away 2-in. thick fiberglass filters.
4. Filters shall be standard, commercially available sizes.
5. Only one size filter per unit is allowed.

23 81 19.13.M. Evaporator Fan and Motor

1. Evaporator fan motor:
 - a. Shall have permanently lubricated bearings.
 - b. Shall have inherent automatic-reset thermal overload protection or circuit breaker.
 - c. Shall have a maximum continuous bhp rating for continuous duty operation; no safety factors above that rating shall be required.
2. Belt-driven Evaporator Fan:
 - a. Belt drive shall include an adjustable pitch motor pulley.
 - b. Shall use sealed, permanently lubricated ball-bearing type.
 - c. Blower fan shall be double-inlet type with forward-curved blades.
 - d. Shall be constructed from steel with a corrosion resistant finish and dynamically balanced.

23 81 19.13.N. Condenser Fans and Motors

1. Condenser fan motors:
 - a. Shall be a totally enclosed motor.
 - b. Shall use permanently lubricated bearings.
 - c. Shall have inherent thermal overload protection with an automatic reset feature.
 - d. Shall use a shaft-down design on 04 to 12 and 16 models and shaft-up on 14 size with rain shield.
2. Condenser Fans:
 - a. Shall be a direct-driven propeller type fan.
 - b. Shall have galvalum blades riveted to corrosion-resistant steel spiders and shall be dynamically balanced.

23 81 19.13.O. Special Features Options and Accessories

1. Staged Air Volume System (SAV) for 2-stage cooling models only:
 - a. Evaporator fan motor:
 - (1.) Shall have permanently lubricated bearings.
 - (2.) Shall have a maximum continuous bhp rating for continuous duty operation; no safety factors above that rating.
 - (3.) Shall be Variable Frequency duty and 2-speed control.
 - (4.) Shall contain motor shaft grounding ring to prevent electrical bearing fluting damage by safely diverting harmful shaft voltages and bearing currents to ground.

2. Variable Frequency Drive (VFD). Only available on 2-speed indoor fan motor option (SAV):
 - a. Shall be installed inside the unit cabinet, mounted, wired and tested.
 - b. Shall contain Electromagnetic Interference (EMI) frequency protection.
 - c. Insulated Gate Bi-Polar Transistors (IGBT) used to produce the output pulse width modulated (PWM) waveform, allowing for quiet motor operation.
 - d. Self diagnostics with fault and power code LED indicator. Field accessory Display Kit available for further diagnostics and special setup applications.
 - e. RS485 capability standard.
 - f. Electronic thermal overload protection.
 - g. 5% swinging chokes for harmonic reduction and improved power factor.
 - h. All printed circuit boards shall be conformal coated.
3. Standard Integrated Economizers (Factory installed on 3 Phase Models Only. Field installed on all 3 and 1 Phase Models):
 - a. Integrated, gear-driven opposing modulating blade design type capable of simultaneous economizer and compressor operation.
 - b. Independent modules for vertical or horizontal return configurations shall be available. Vertical return modules shall be available as a factory installed option.
 - c. Damper blades shall be galvanized steel with composite gears. Plastic or composite blades on intake or return shall not be acceptable.
 - d. Shall include all hardware and controls to provide free cooling with outdoor air when temperature and/or humidity are below setpoints.
 - e. Shall be equipped with gear driven dampers for both the outdoor ventilation air and the return air for positive air stream control.
 - f. Standard models shall be equipped with low-leakage dampers, not to exceed 2% leakage at 1 in. wg pressure differential. Economizer controller on electromechanical units shall be Honeywell W7212 that provides:
 - (1.) Combined minimum and DCV maximum damper position potentiometers with compressor staging relay.
 - (2.) Functions with solid state analog enthalpy or dry bulb changeover control sensing.
 - (3.) Contain LED indicates for:
 - when free cooling is available
 - when module is in DCV mode
 - when exhaust fan contact is closed
 - g. Ultra low leak EconoMi\$er X system shall be available on models with SAV 2-speed Variable Frequency Drive (VFD) systems. Only available on 2-speed indoor fan motor systems with electromechanical controls or RTU Open.
 - (1.) Maximum damper leakage rate to be equal to or less than 4.0 cfm/sq. ft. at 1.0 in. w.g., meeting or exceeding ASHRAE 90.1 requirements. Economizer controller on electromechanical units shall be Honeywell W7220 that provides:
 - (2.) 2-line LCD interface screen for setup, configuration and troubleshooting
 - (3.) On-board fault detection and diagnostics
 - (4.) Sensor failure loss of communication identification
 - (5.) Automatic sensor detection
 - (6.) Capabilities for use with multiple-speed indoor fan systems
 - (7.) Utilize digital sensors: Dry bulb and Enthalpy
 - h. Shall be capable of introducing up to 100% outdoor air.
 - i. Shall be equipped with a barometric relief damper capable of relieving up to 100% return air.
 - j. Shall be designed to close damper(s) during loss-of-power situations with spring return built into motor.
 - k. Dry bulb outdoor air temperature sensor shall be provided as standard. Outdoor air sensor setpoint shall be adjustable and shall range from 40 to 100° F / 4 to 38° C. Additional sensor options shall be available as accessories.
 - l. The economizer controller shall also provide control of an accessory power exhaust unit function. Factory set at 100%, with a range of 0% to 100%.
 - m. The economizer shall maintain minimum airflow into the building during occupied period and provide design ventilation rate for full occupancy. A remote potentiometer may be used to override the damper setpoint.

- n. Dampers shall be completely closed when the unit is in the unoccupied mode.
 - o. Economizer controller shall accept a 2-10 Vdc CO₂ sensor input for IAQ/DCV control. In this mode, dampers shall modulate the outdoor air damper to provide ventilation based on the sensor input.
 - p. Compressor lockout sensor shall open at 35°F (2°C) and close closes at 50°F (10°C).
 - q. Actuator shall be direct coupled to economizer gear. No linkage arms or control rods shall be acceptable.
 - r. Economizer controller shall provide indications when in free cooling mode, in the DCV mode, or the exhaust fan contact is closed.
4. Two-Position Damper (Factory installed on 3 Phase Models Only. Field installed on all 3 and 1 Phase Models)
 - a. Damper shall be a Two-Position Damper. Damper travel shall be from the full closed position to the field adjustable %-open setpoint.
 - b. Damper shall include adjustable damper travel from 25% to 100% (full open).
 - c. Damper shall include single or dual blade, gear driven dampers and actuator motor.
 - d. Actuator shall be direct coupled to damper gear. No linkage arms or control rods shall be acceptable.
 - e. Damper will admit up to 100% outdoor air for applicable rooftop units.
 - f. Damper shall close upon indoor (evaporator) fan shutoff and/or loss of power.
 - g. The damper actuator shall plug into the rooftop unit's wiring harness plug. No hard wiring shall be required.
 - h. Outside air hood shall include aluminum water entrainment filter.
 5. Manual damper
 - a. Manual damper package shall consist of damper, air inlet screen, and rain hood which can be preset to admit up to 25 or 50% outdoor air for year round ventilation.
 6. Humidi-MiZer Adaptive Dehumidification System (3 Phase Models Only):
 - a. The Humidi-MiZer Adaptive Dehumidification System shall be factory installed in single stage 48TC04-07 and 2-stage 48TC08-16 models with RTPF (round tube plate tin) condenser coils, and shall provide greater dehumidification of the occupied space by two modes of dehumidification operations in addition to its normal design cooling mode:
 - (1.) Subcooling mode further sub cools the hot liquid refrigerant leaving the condenser coil when both temperature and humidity in the space are not satisfied.
 - (2.) Hot gas reheat mode shall mix a portion of the hot gas from the discharge of the compressor with the hot liquid refrigerant leaving the condenser coil to create a two-phase heat transfer in the system, resulting in a neutral leaving air temperature when only humidity in the space is not satisfied.
 - (3.) Includes head pressure controller.
 7. Head Pressure Control Package
 - a. Controller shall control coil head pressure by condenser fan speed modulation or condenser fan cycling and wind baffles.
 - b. Shall consist of solid-state control and condenser coil temperature sensor to maintain condensing temperature between 90°F (32°C) and 110°F (43°C) at outdoor ambient temperatures down to -20°F (-29°C).
 8. Propane Conversion Kit
 - a. Package shall contain all the necessary hardware and instructions to convert a standard natural gas unit for use with liquefied propane, up to 2000 ft (610m) elevation.
 - b. Additional accessory kits may be required for applications above 2000 ft (610m) elevation.
 9. Flue Shield (04-14 sizes only)
 - a. Flue shield shall provide protection from the hot sides of the gas flue hood.
 10. Condenser Coil Hail Guard Assembly (Factory installed on 3 Phase Models Only. Field installed on all 3 and 1 Phase Models)
 - a. Shall protect against damage from hail.
 - b. Shall be either hood style or louvered.
 11. Unit-Mounted, Non-Fused Disconnect Switch (Available on units with MOCP's of 80 amps or less):
 - a. Switch shall be factory installed, internally mounted.
 - b. National Electric Code (NEC) and UL approved non-fused switch shall provide unit power shutoff.
 - c. Shall be accessible from outside the unit.
 - d. Shall provide local shutdown and lockout capability.
 12. Convenience Outlet:
 - a. Powered convenience outlet. (3 Phase Models Only)
 - (1.) Outlet shall be powered from main line power to the rooftop unit.

- (2.) Outlet shall be powered from line side or load side of disconnect by installing contractor, as required by code. If outlet is powered from load side of disconnect, unit electrical ratings shall be UL certified and rated for additional outlet amperage.
 - (3.) Outlet shall be factory installed and internally mounted with easily accessible 115-v female receptacle.
 - (4.) Outlet shall include 15 amp GFI receptacles with independent fuse protection.
 - (5.) Voltage required to operate convenience outlet shall be provided by a factory installed step-down transformer.
 - (6.) Outlet shall be accessible from outside the unit.
 - (7.) Outlet shall include a field installed "Wet in Use" cover.
- b. Non-Powered convenience outlet.
 - (1.) Outlet shall be powered from a separate 115/120v power source.
 - (2.) A transformer shall not be included.
 - (3.) Outlet shall be factory installed and internally mounted with easily accessible 115-v female receptacle.
 - (4.) Outlet shall include 15 amp GFI receptacles with independent fuse protection.
 - (5.) Outlet shall be accessible from outside the unit.
 - (6.) Outlet shall include a field installed "Wet in Use" cover.
13. Flue Discharge Deflector (04-14 sizes only):
 - a. Flue discharge deflector shall direct unit exhaust vertically instead of horizontally.
 - b. Deflector shall be defined as a "natural draft" device by the National Fuel and Gas (NFG) code.
14. Thru-the-Base Connectors:
 - a. Kits shall provide connectors to permit gas and electrical connections to be brought to the unit through the unit basepan.
 - b. Minimum of four connection locations per unit.
15. Supply Duct Cover: (16 size only.)
 - a. Required when field converting the factory standard vertical duct supply to horizontal duct supply configuration. One required per unit.
16. Propeller Power Exhaust:
 - a. Power exhaust shall be used in conjunction with an integrated economizer.
 - b. Independent modules for vertical or horizontal return configurations shall be available.
 - c. Horizontal power exhaust is shall be mounted in return ductwork.
 - d. Power exhaust shall be controlled by economizer controller operation. Exhaust fans shall be energized when dampers open past the 0-100% adjustable setpoint on the economizer control.
17. Roof Curbs (Vertical):
 - a. Full perimeter roof curb with exhaust capability providing separate air streams for energy recovery from the exhaust air without supply air contamination.
 - b. Formed galvanized steel with wood nailer strip and shall be capable of supporting entire unit weight.
 - c. Permits installation and securing of ductwork to curb prior to mounting unit on the curb.
18. High Altitude Gas Conversion Kit:
 - a. Package shall contain all the necessary hardware and instructions to convert a standard natural gas unit to operate from 2000-7000 ft (610 to 2134m) elevation with natural gas or from 0-7000 ft (90-2134m) elevation with liquefied propane.
19. Outdoor Air Enthalpy Sensor:
 - a. The outdoor air enthalpy sensor shall be used to provide single enthalpy control. When used in conjunction with a return air enthalpy sensor, the unit will provide differential enthalpy control. The sensor allows the unit to determine if outside air is suitable for free cooling.
20. Return Air Enthalpy Sensor:
 - a. The return air enthalpy sensor shall be used in conjunction with an outdoor air enthalpy sensor to provide differential enthalpy control.
21. Indoor Air Quality (CO₂) Sensor:
 - a. Shall be able to provide demand ventilation indoor air quality (IAQ) control.
 - b. The IAQ sensor shall be available in duct mount, wall mount, or wall mount with LED display. The setpoint shall have adjustment capability.
22. Smoke detectors (factory installed only):
 - a. Shall be a Four-Wire Controller and Detector.
 - b. Shall be environmental compensated with differential sensing for reliable, stable, and drift-free sensitivity.

- c. Shall use magnet-activated test/reset sensor switches.
 - d. Shall have tool-less connection terminal access.
 - e. Shall have a recessed momentary switch for testing and resetting the detector.
 - f. Controller shall include:
 - (1.) One set of normally open alarm initiation contacts for connection to an initiating device circuit on a fire alarm control panel.
 - (2.) Two Form-C auxiliary alarm relays for interface with rooftop unit or other equipment.
 - (3.) One Form-C supervision (trouble) relay to control the operation of the Trouble LED on a remote test/reset station.
 - (4.) Capable of direct connection to two individual detector modules.
 - (5.) Can be wired to up to 14 other duct smoke detectors for multiple fan shutdown applications
23. Winter start kit
- a. Shall contain a bypass device around the low pressure switch.
 - b. Shall be required when mechanical cooling is required down to 25°F (-4°C).
 - c. Shall not be required to operate on an economizer when below an outdoor ambient of 40°F (4°C).
24. Time Guard
- a. Shall prevent compressor short-cycling by providing a 5-minute delay (± 2 minutes) before restarting a compressor after shutdown for any reason.
 - b. One device shall be required per compressor.
25. Disconnect Switch Bracket (16 size only)
- a. Provides a pre-engineered and sized mounting bracket for applications requiring a unit mounted fused and non-fused disconnect of greater than 100 amps. Bracket assures that no damage will occur to coils when mounting with screws and other fasteners.
26. California OSHPD Seismic Certification Label
- a. Units meet the seismic capacity requirements of the International Code Council Evaluation Service (ICC-ES) document AC156 (Acceptance Criteria for Seismic Qualification by Shake-Table Testing of Nonstructural Components and Systems) and per International Building Code (IBC 2009) at an SDS (g) value of 2.00 z/h=1.0, Ip=1.5 and certified by independent structural engineers.
 - b. Units shall include a certification label that meets the CA OSHPD Special Seismic Certification pre-approval labeling requirements on the external chassis of the unit.
27. Hinged Access Panels
- a. Shall provide easy access through integrated quarter turn latches.
 - b. Shall be on major panels of: filter, control box, fan motor, and compressor.
28. Display Kit for Variable Frequency Drive
- a. Kit allows the ability to access the VFD controller programs to provide special setup capabilities and diagnostics.
 - b. Kit contains display module, mounting bracket and communication cable.
 - c. Display Kit can be permanently installed in the unit or used on any SAV system VFD controller as needed.

