

MODEL: DFF2HU			QT'Y/UNIT						PRICE/PC	PRICE/UNIT
ITEM	PART NAME	PART NUMBER	18AWAT	24AWAT	30AWAT	36AWAT	48AWAT	60AWAT		(USD)
1	HOUSING	FCT040401								
	HOUSING	FCT060601	1							
	HOUSING	FCT081001		1	1	1				
	HOUSING	FCT121201					1			
	HOUSING	FCT161601						1		
	HOUSING	FCT202001								
2	FRONT PANEL	FCT040602	1							
	FRONT PANEL	FCT081002		1	1	1				
	FRONT PANEL	FCT121202					1			
	FRONT PANEL	FCT162002						1		
3	MOTOR HOUSING	FCT040403								
	MOTOR HOUSING	FCT060603	1							
	MOTOR HOUSING	FCT080803		1	1					
	MOTOR HOUSING	FCT101003				1				
	MOTOR HOUSING	FCT121203					1			
	MOTOR HOUSING	FCT161603						1		
	MOTOR HOUSING	FCT202003								
4	WATER TRAY	FCT040604	1							
	WATER TRAY	FCT081004		1	1	1				
	WATER TRAY	FCT121204					1			
	WATER TRAY	FCT162004						1		
5										
6	TOP PANEL	FCT040406								
	TOP PANEL	FCT060606	1							
	TOP PANEL	FCT081006		1	1	1				
	TOP PANEL	FCT121206					1			
	TOP PANEL	FCT161606						1		
	TOP PANEL	FCT202006								
7	HANGER ARM/LM	FCT040407								
	HANGER ARM/LM	FCT061607	1	1	1	1	1	1		
	HANGER ARM/LM	FCT202007								
8	HANGER ARM/RM	FCT040408								
	HANGER ARM/RM	FCT061608	1	1	1	1	1	1		
	HANGER ARM/RM	FCT202008								
9	PLATE-COVER COIL TOP	FCT040409								
	PLATE-COVER COIL TOP	FCT060609	1							
	PLATE-COVER COIL TOP	FCT081009		1	1	1				
	PLATE-COVER COIL TOP	FCT121209					1			
	PLATE-COVER COIL TOP	FCT161609						1		
	PLATE-COVER COIL TOP	FCT202009								
10	COIL FIXTOR/RH	FCT040410								
	COIL FIXTOR/RH	FCT060610	1							
	COIL FIXTOR/RH	FCT080810		1						
	COIL FIXTOR/RH	FCT300010			1					
	COIL FIXTOR/RH	FCT101010				1				
	COIL FIXTOR/RH	FCT121210					1			
	COIL FIXTOR/RH	FCT161610						1		
	COIL FIXTOR/RH	FCT202010								
11	COIL FIXTOR/LH	FCT040411								
	COIL FIXTOR/LH	FCT060611	1							
	COIL FIXTOR/LH	FCT080811		1						
	COIL FIXTOR/LH	FCT300011			1					
	COIL FIXTOR/LH	FCT101011				1				
	COIL FIXTOR/LH	FCT121211					1			
	COIL FIXTOR/LH	FCT161611						1		
12	LOCK-FRONT PANEL	FCT042012	2	2	2	2	2	2		
13	SIDE PANEL TOP	FCT042013	1	1	1	1	1	1		
14										
15	EVAPORATOR COIL	FCT040415								
	EVAPORATOR COIL	FCT060615	1							
	EVAPORATOR COIL	FCT080815		1						
	EVAPORATOR COIL	FCT101015			1					
	EVAPORATOR COIL	FCT121215				1				
	EVAPORATOR COIL	FCT161615					1			
	EVAPORATOR COIL	FCT200215						1		

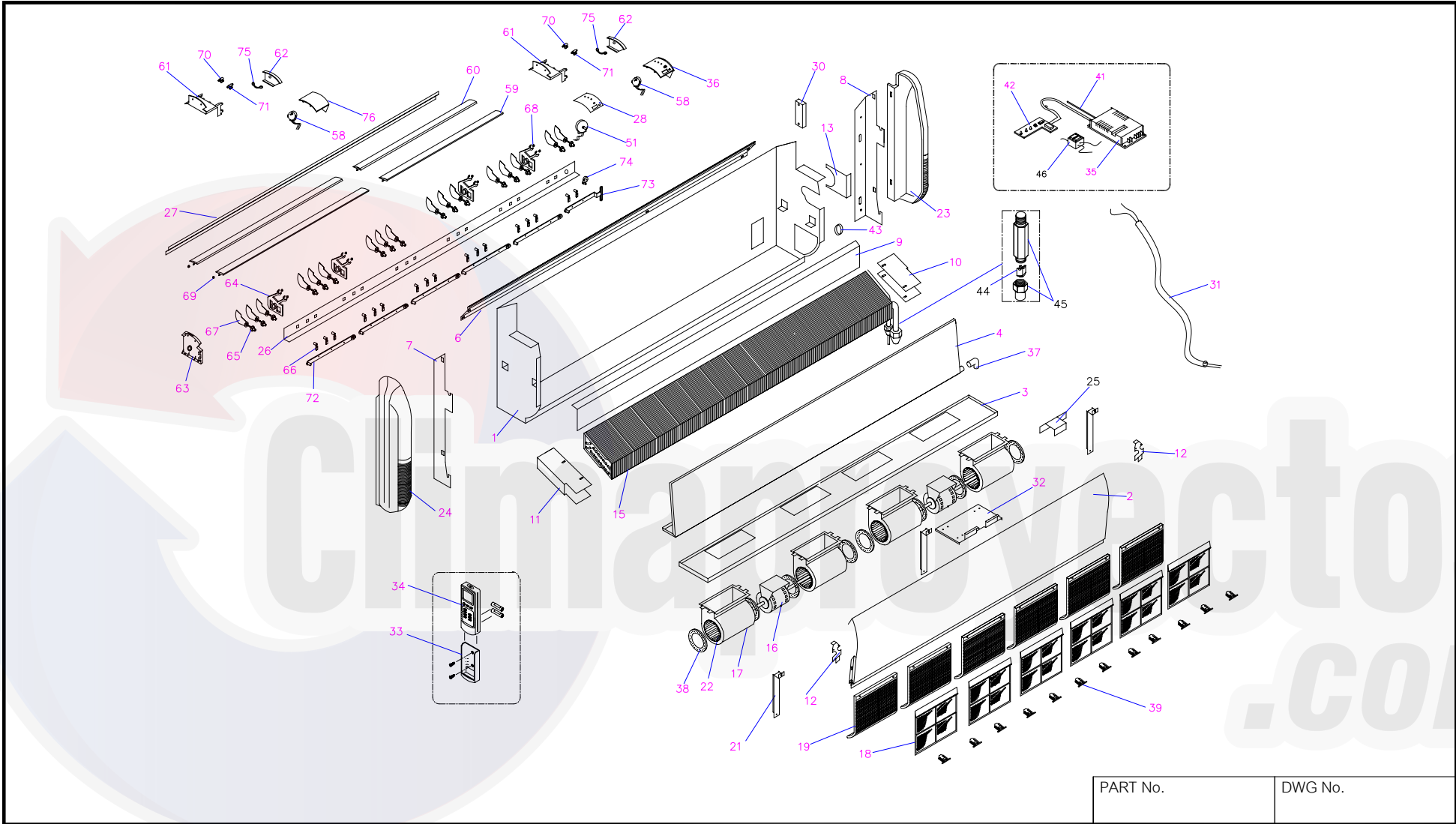

PART No.	DWG No.
----------	---------

--	--	--

PPJ	
ENGINEERING CO., LTD.	
UNIT:	SCALE:
MAT:	WEIGHT:
REV	SHEET
00	1/1

	DRAWN	CHECKED	APPROVED
TITLE:			
DFF2HU48AWAT			

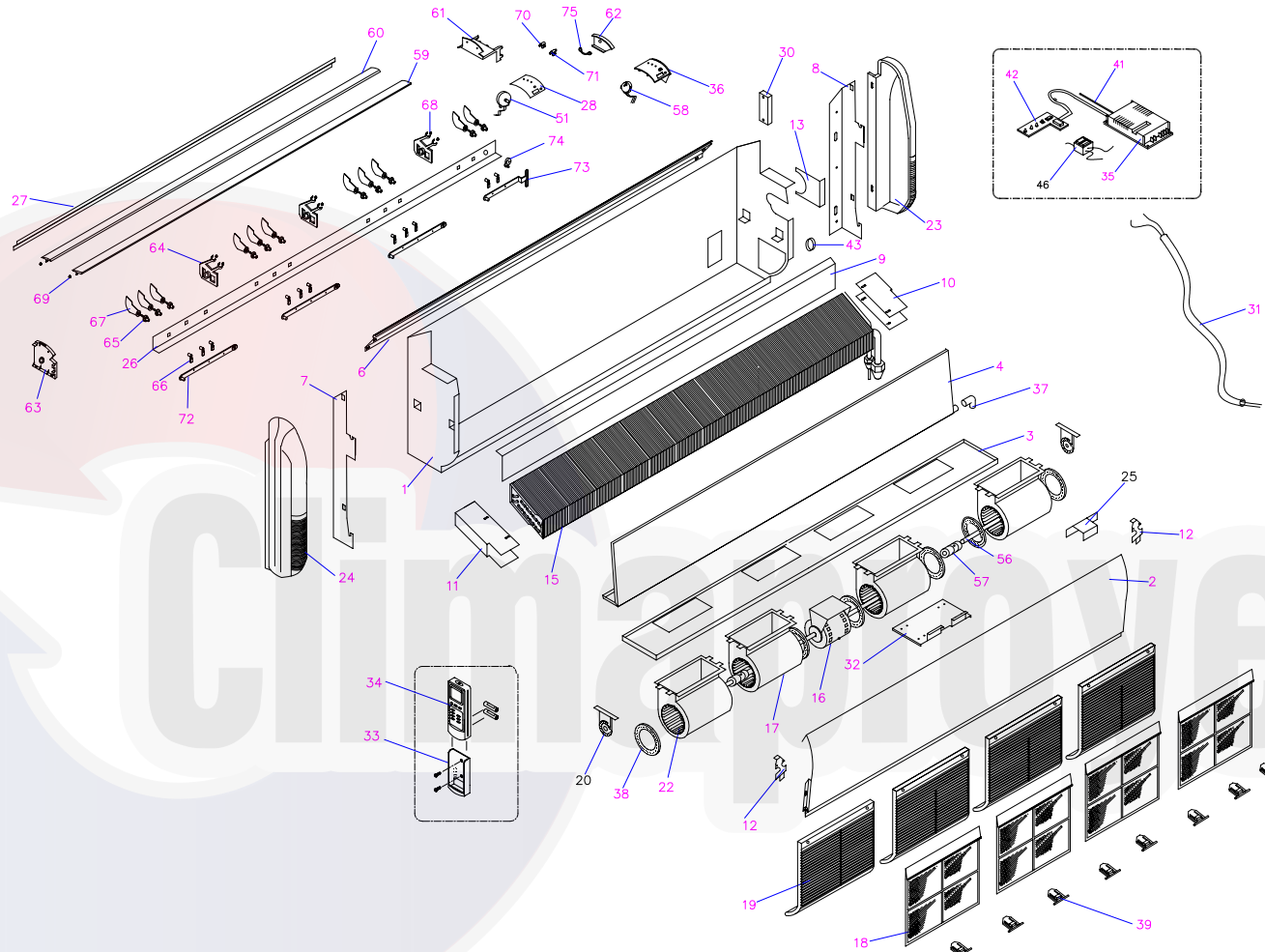

PART No.	DWG No.
----------	---------

PPJ
ENGINEERING CO., LTD.

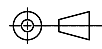

DRAWN	CHECKED	APPROVED

UNIT:	SCALE:
MAT:	WEIGHT:
REV	SHEET
00	1/1

TITLE:
DFF2HU36AWAT

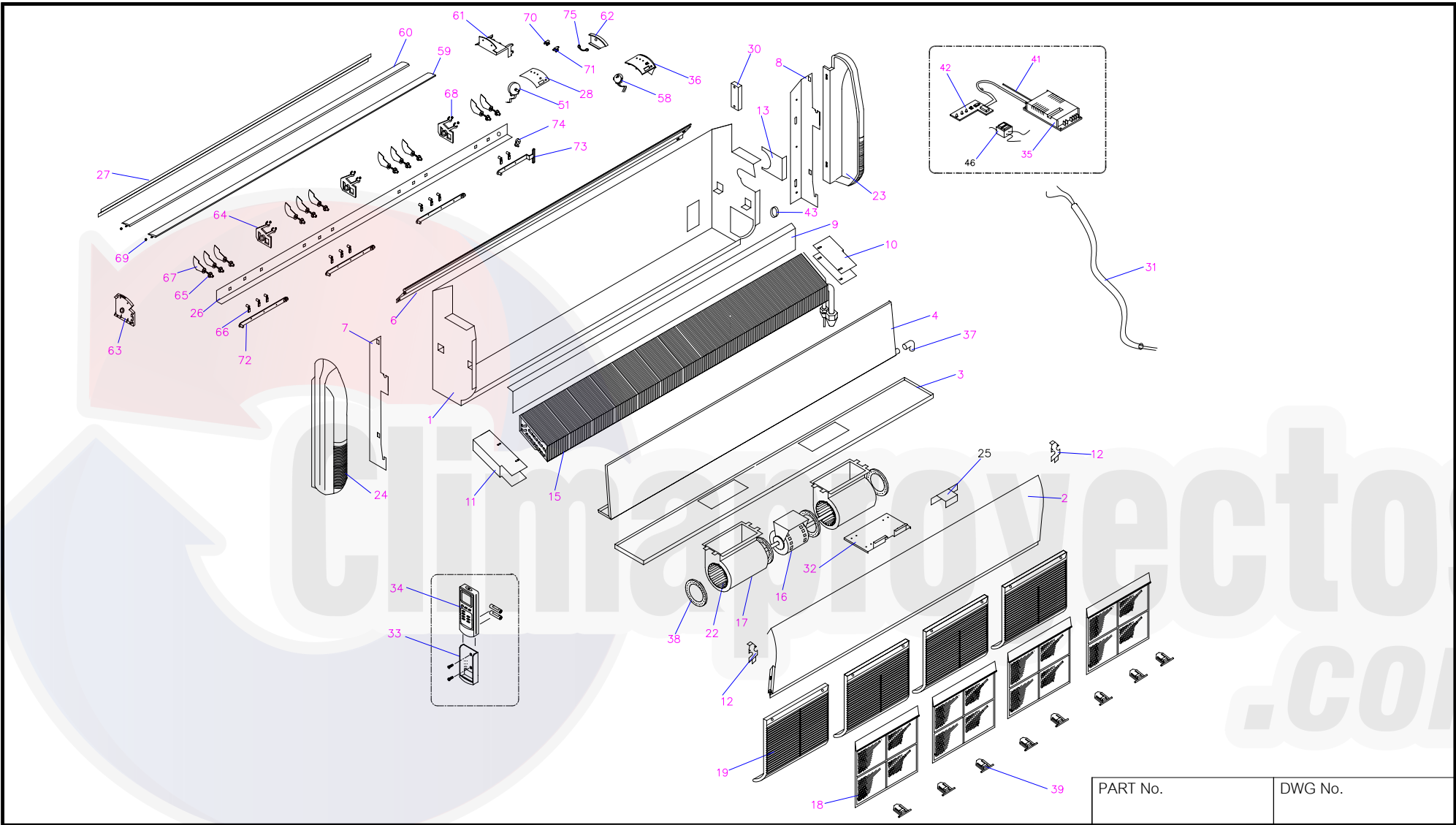

PART No.	DWG No.
----------	---------

--	--	--

PPJ ENGINEERING CO., LTD.	
UNIT:	SCALE:
MAT:	WEIGHT:
REV	SHEET
00	1/1

	DRAWN	CHECKED	APPROVED
TITLE:			
DFF2HU30AWAT			

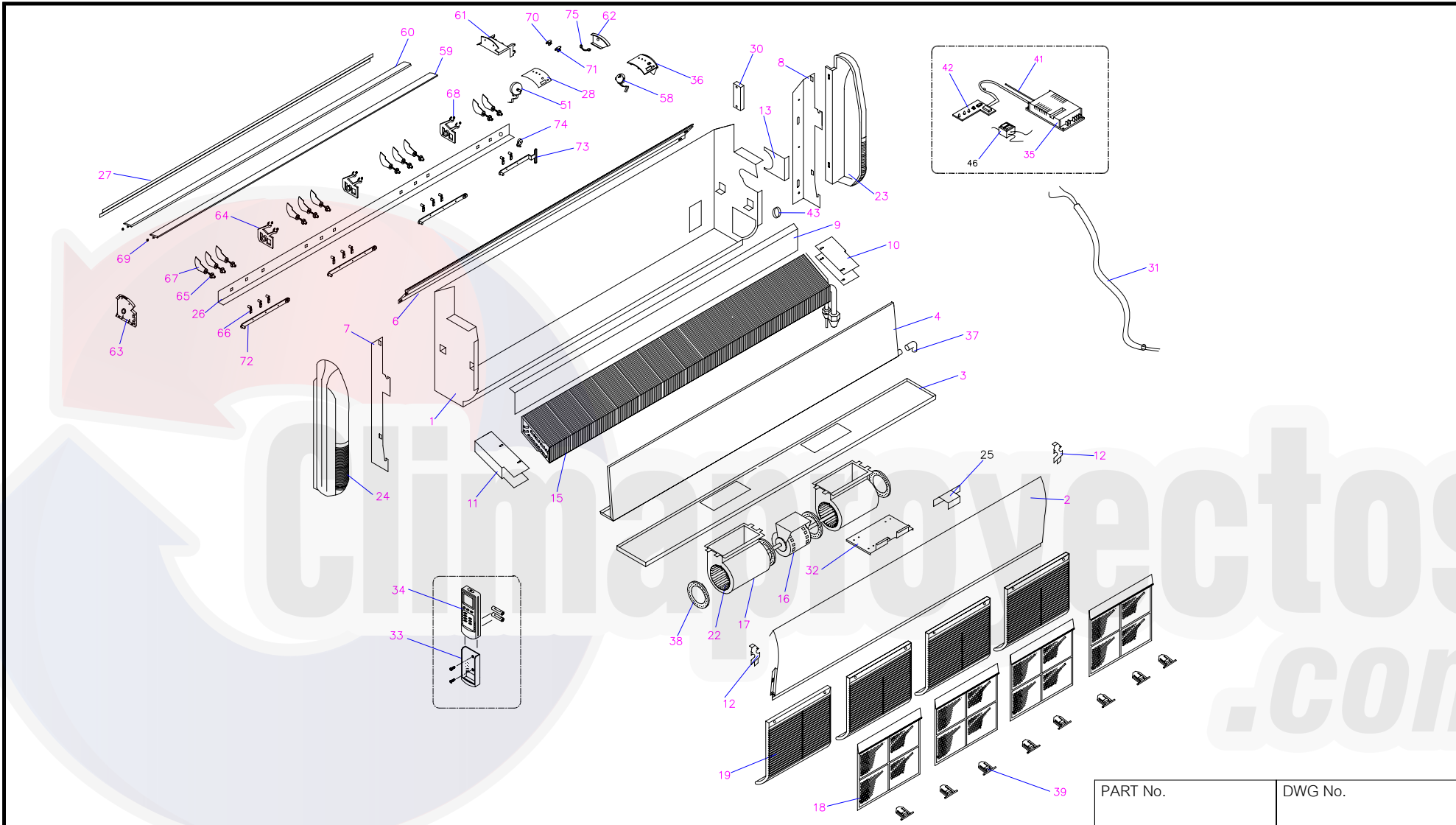

PART No.	DWG No.
----------	---------

--	--	--

PPJ
ENGINEERING CO., LTD.

	DRAWN	CHECKED	APPROVED

UNIT:	SCALE:
MAT:	WEIGHT:
REV	SHEET
00	1/1

TITLE:
DFF2HU24AWAT

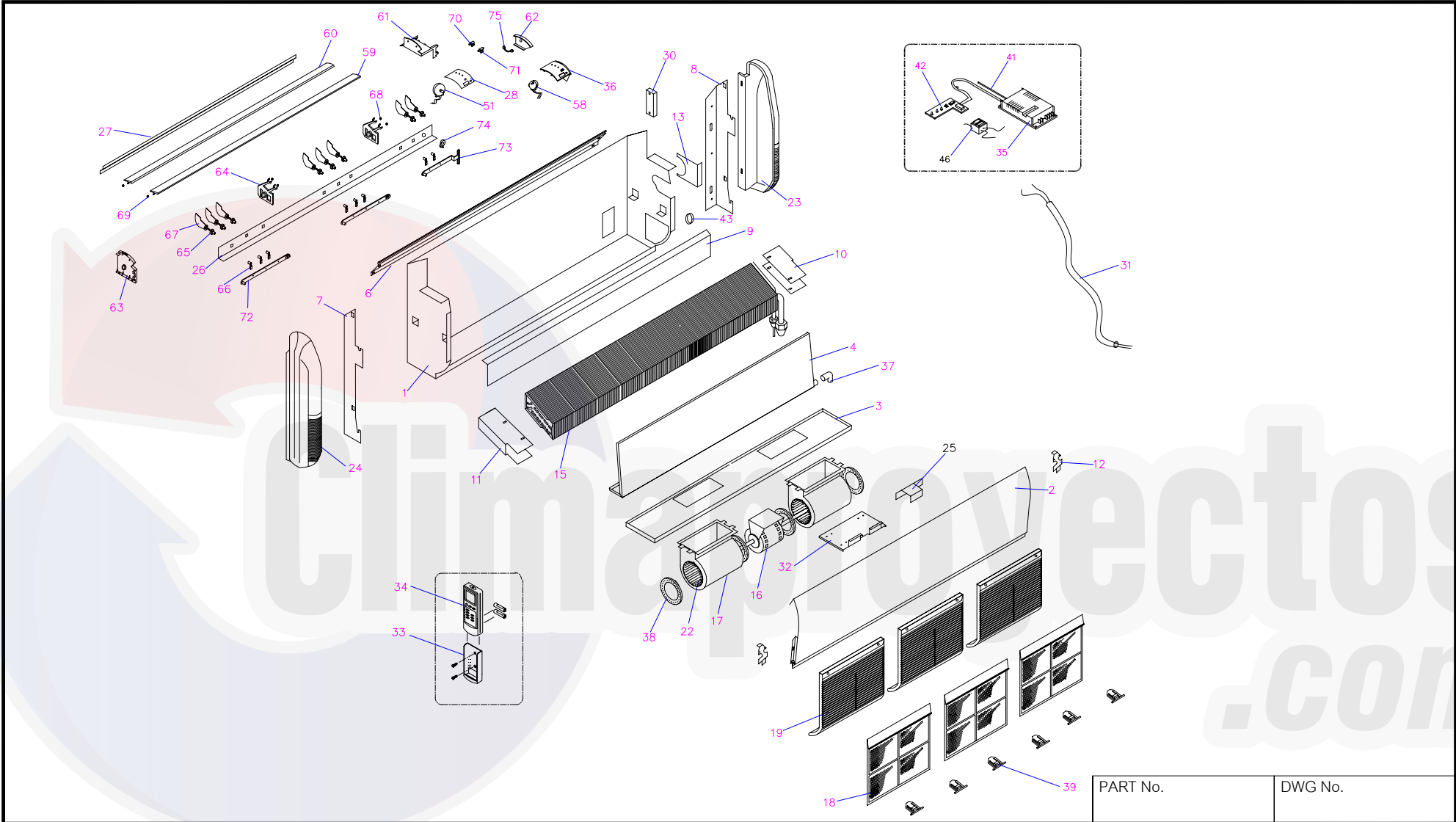

PART No.	DWG No.
----------	---------

			<h1>PPJ</h1> <p>ENGINEERING CO., LTD.</p>		DRAWN	CHECKED	APPROVED		
					UNIT:	SCALE:	TITLE: DFF2HU18AWAT		
					MAT:	WEIGHT:			
					REV	SHEET			
00	1/1								

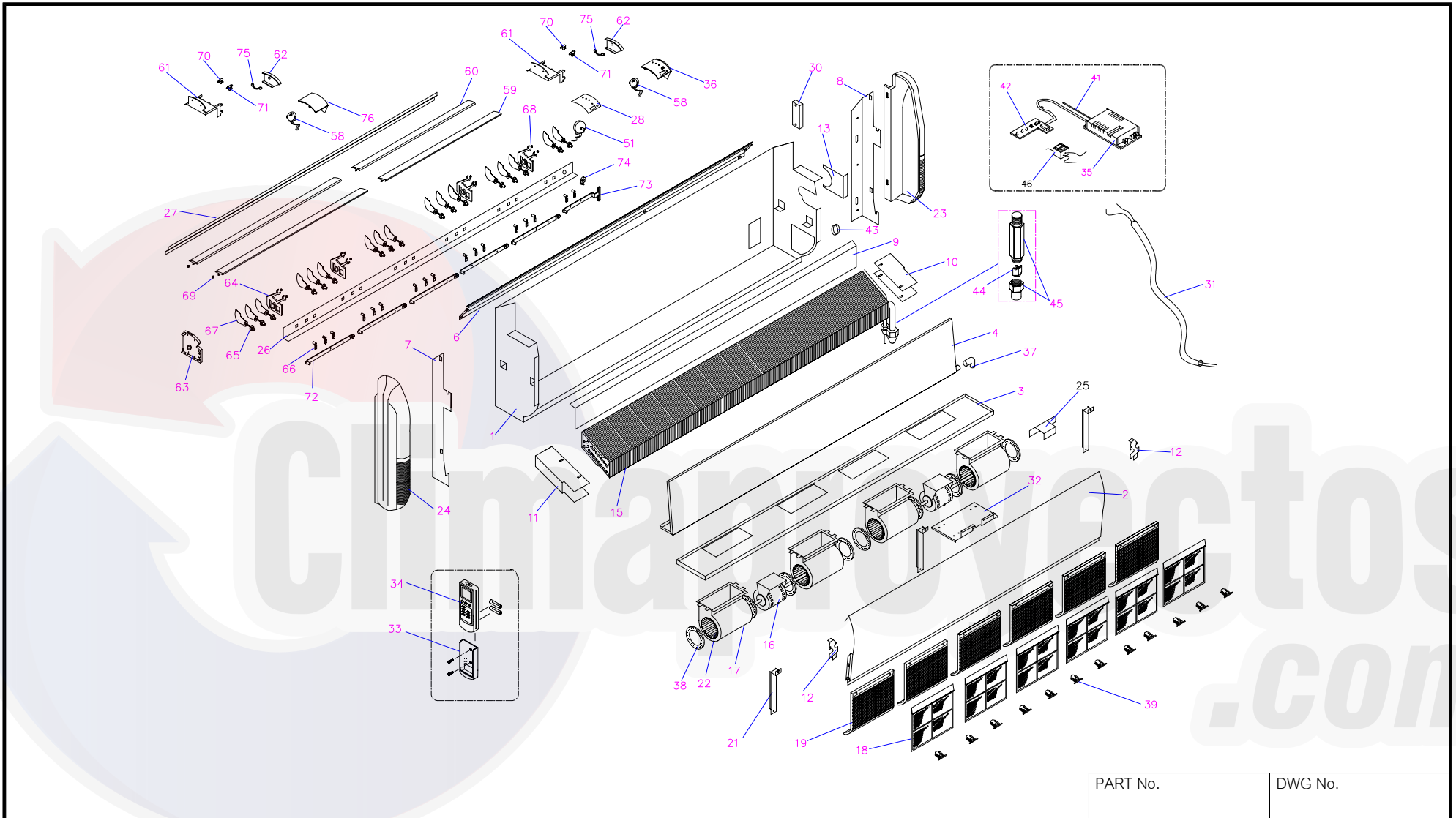

PART No.	DWG No.
----------	---------

			PPJ ENGINEERING CO., LTD.		DRAWN	CHECKED	APPROVED
					TITLE:		
					DFF2HU60AWAT		
UNIT:	SCALE:						
MAT:	WEIGHT:						
REV	SHEET						
00	1/1						

MODEL: DFF2HU			QT'Y/UNIT						PRICE/PC	PRICE/UNIT
ITEM	PART NAME	PART NUMBER	18AWAT	24AWAT	30AWAT	36AWAT	48AWAT	60AWAT	(USD)	
16	FAN MOTOR	FCT040416								
	FAN MOTOR	FCT060616	1	1						
	FAN MOTOR	FCT101016			1	1		2		
	FAN MOTOR	FCT161616					2			
17	HOUSING BLOWER	FCT040417								
	HOUSING BLOWER	FCT060617	2							
	HOUSING BLOWER	FCT080817		2	2			4		
	HOUSING BLOWER	FCT121217				4				
	HOUSING BLOWER	FCT161617					4			
18	AIR FILTER 300	FCT042018	3	4	4	4	5	6		
19	RETURN GRILL 300	FCT042019	3	4	4	4	5	6		
20	BUSH-SUPPORT BLOWER	FCT101020				2				
21	SUPPORT-MOTOR HOUSING A	FCT081621					1	1		
	SUPPORT-MOTOR HOUSING B	FCT202021					2	2		
22	BLOWER WHEEL	FCT040422								
	BLOWER WHEEL	FCT060622	2							
	BLOWER WHEEL	FCT080822		2	2			4		
	BLOWER WHEEL	FCT121222				4				
	BLOWER WHEEL	FCT161622					4			
23	SIDE PANEL RIGHT	FCT042023	1	1	1	1	1	1		
24	SIDE PANEL LEFT	FCT042024	1	1	1	1	1	1		
25										
26	SUPPORT GRILL FRONT	FCT040626	1							
	SUPPORT GRILL FRONT	FCT081026		1	1	1				
	SUPPORT GRILL FRONT	FCT121226					1			
	SUPPORT GRILL FRONT	FCT162026						1		
27	SUPPORT GRILL BACK	FCT040627	1							
	SUPPORT GRILL BACK	FCT081027		1	1	1				
	SUPPORT GRILL BACK	FCT121227					1			
	SUPPORT GRILL BACK	FCT162027						1		
28	STICKER-DISPLAY	FCT040628	1	1	1	1	1	1		
29										
30	TERMINAL	FCT042030	1	1	1	1	1	1		
31	INTERNAL LINE	FCT042031	1	1	1	1	1	1		
32	SUPPORT REMOTE*	FCT042032	1	1	1	1	1	1		
33	HANGER-REMOTE CONTROLLER	FCT042033	1	1	1	1	1	1		
34	WIRELESS REMOTE	FCT042034	1	1	1	1	1	1		
35	MAIN P.C. BOARD	FCT042035	1	1	1	1	1	1		
36	RECEIVER HOLDER	FCT042036	1	1	1	1	1	1		
37	DRAIN HOSE ELBOW	FCT042037	1	1	1	1	1	1		
38	BLOWER COVER	FCT040438								
	BLOWER COVER	FCT061638	4	4	4	8	8	8		
	BLOWER COVER	FCT202038								
39	LOCK-RETURN	FCT042039	6	8	8	8	10	12		
40										
41	ROOM SENSOR	FCT042041	1	1	1	1	1	1		
42	DISPLAY P.C.DISPLAY	FCT042042	1	1	1	1	1	1		
43	RUBBER#5	FCT042043	1	1	1	1	1	1		
44	FLOW CONTROL	FCT040444								
	FLOW CONTROL	FCT060644	1							
	FLOW CONTROL	FCT080844		1						
	FLOW CONTROL	FCT101044			1					
	FLOW CONTROL	FCT121244				1				
	FLOW CONTROL	FCT161644					1			
	FLOW CONTROL	FCT200244						1		
45	SOCKET-FLOW CONTROL	FCT042045	1	1	1	1	1	1		
46										
47	SUCTION PIPE CONNECTOR	FCT040447								
	SUCTION PIPE CONNECTOR	FCT061047								
	SUCTION PIPE CONNECTOR	FCT122047								
48	LIQUID PIPE CONNECTOR	FCT040448								
	LIQUID PIPE CONNECTOR	FCT061648								
	LIQUID PIPE CONNECTOR	FCT202048								
49										
50	ROTATABLE VANE 300	FCT042050								

MODEL: DFF2HU			QT'Y/UNIT						PRICE/PC	PRICE/UNIT
ITEM	PART NAME	PART NUMBER	18AWAT	24AWAT	30AWAT	36AWAT	48AWAT	60AWAT		(USD)
51	SYNCHRONOUS MOTOR	FCT042051	1	1	1	1	1	1		
52										
53										
54										
55	BUSH-ROTATABLE VANE	FCT042055	-	-	-	-	-	-		
56	SHAFT	FCT101056				2				
57	JOINT	FCT101057				2				
58	STEP-MOTOR	FCT042058	1	1	1	1	2	2		
59	SWING BLADE -BOTTOM 820	FCT040659	1					2		
	SWING BLADE -BOTTOM 1120	FCT081059		1	1	1				
	SWING BLADE -BOTTOM 670	FCT121259					2			
60	SWING BLADE -TOP 820	FCT040660	1					2		
	SWING BLADE -TOP 1120	FCT081060		1	1	1				
	SWING BLADE -TOP 670	FCT121260					2			
61	SUPPORT RECIVER	FCT042061	1	1	1	1	2	2		
62	COVER	FCT042062	1	1	1	1	2	2		
63	SUPPORT SIDE PANEL LEFT	FCT042063	1	1	1	1	1	1		
64	SUPPORT BLADE	FCT042064	2	3	3	3	4	4		
65	LOCK VANE	FCT042065	8	11	11	11	12	16		
66	LINK VANE	FCT042066	8	11	11	11	12	16		
67	VANE	FCT042067	8	11	11	11	12	16		
68	BUSH SWING-MED	FCT042068	4	6	6	6	8	8		
69	BUSH SWING-SIDE	FCT042069	2	2	2	2	4	4		
70	SWING CAM-TOP	FCT042070	1	1	1	1	2	2		
71	SWING CAM-BOTTOM	FCT042071	1	1	1	1	2	2		
72	LINK ROD TO ROD 300	FCT042072	2	3	3	3	3	5		
	LINK ROD TO ROD 150	FCT121272					2			
73	LINK ROD TO MOTOR	FCT042073	1	1	1	1	1	1		
74	VANE-CAM	FCT042074	1	1	1	1	1	1		
75	SWING LINK	FCT042075	1	1	1	1	2	2		
76	SUPPORT SWING COVER	FCT121276					1	1		