



# Controls, Start-Up, Operation, Service and Troubleshooting

## CONTENTS

	Page		Page
<b>SAFETY CONSIDERATIONS</b> .....	2,3	• DUAL CHILLER CONTROL FOR SERIES APPLICATIONS	
<b>GENERAL</b> .....	3-8	• DUAL CHILLER PUMP CONTROL FOR SERIES CHILLER APPLICATIONS	
<b>Conventions Used in This Manual</b> .....	3	<b>Night Time/Low Noise Applications</b> .....	37
<b>Display Module Usage</b> .....	3	<b>Ramp Loading</b> .....	38
• TOUCH PILOT™ DISPLAY		<b>Temperature Reset</b> .....	38
• NAVIGATOR™ DISPLAY MODULE		• RETURN WATER RESET	
<b>CONTROLS</b> .....	8-21	• OUTSIDE AIR TEMPERATURE RESET	
<b>General</b> .....	8	• SPACE TEMPERATURE RESET	
<b>Main Base Board (MBB)</b> .....	8	• 4-20 mA TEMPERATURE RESET	
<b>Compressor Protection Module (CPM)</b> .....	9	<b>Demand Limit</b> .....	42
<b>Electronic Expansion Valve (EXV) Board</b> .....	9	• SWITCH CONTROLLED DEMAND LIMIT	
<b>Fan Boards</b> .....	15	• EXTERNALLY POWERED CAPACITY BASED DEMAND LIMIT	
<b>Enable-Off-Remote Contact Switch (SW1)</b> .....	17	• EXTERNALLY POWERED CURRENT BASED DEMAND LIMIT	
<b>Emergency On/Off Switch (SW2)</b> .....	17	• CCN LOADSHED CONTROLLED DEMAND LIMIT	
<b>Energy Management Module (EMM)</b> .....	17	<b>Ice Storage Operation</b> .....	46
<b>Hot Gas Bypass/Pump Board</b> .....	17	<b>Broadcast Configuration</b> .....	46
<b>Local Equipment Network</b> .....	19	• ACTIVATE	
<b>Board Addresses</b> .....	19	• OAT BROADCAST	
<b>Touch Pilot Display</b> .....	19	• BROADCAST ACKNOWLEDGER	
<b>Control Module Communication</b> .....	19	<b>Alarm Control</b> .....	46
• RED LED		• ALARM ROUTING CONTROL	
• GREEN LED		• ALARM EQUIPMENT PRIORITY	
• YELLOW LED		• COMMUNICATION FAILURE RETRY TIME	
<b>Carrier Comfort Network® (CCN) Interface</b> .....	20	• RE-ALARM TIME	
<b>Remote Alarm and Alert Relays</b> .....	20	• ALARM SYSTEM NAME	
<b>CONFIGURATION</b> .....	21-59	<b>Daylight Saving Time Configuration</b> .....	47
<b>Touch Pilot Operation Configuration Tables</b> .....	21	<b>Capacity Control Overrides</b> .....	47
<b>Machine Control Methods</b> .....	22	<b>Head Pressure Control</b> .....	50
<b>Machine On/Off Control</b> .....	22	• LOW AMBIENT TEMPERATURE HEAD PRESSURE CONTROL OPTION	
• TOUCH PILOT MACHINE CONTROL		• LOW AMBIENT TEMPERATURE HEAD PRESSURE CONTROL OPERATING INSTRUCTIONS	
• NAVIGATOR DISPLAY MACHINE CONTROL		<b>PRE-START-UP</b> .....	59
<b>Fluid Set Point Control Location</b> .....	27	<b>System Check</b> .....	59
<b>Cooling Set Point Selection</b> .....	27	<b>START-UP</b> .....	59-67
• SET POINT OCCUPANCY		<b>Actual Start-Up</b> .....	59
<b>Chilled Water Fluid Type Selection</b> .....	28	<b>Operating Limitations</b> .....	60
• FRESH WATER		• TEMPERATURES	
• BRINE OR GLYCOL OPERATION		• VOLTAGE	
<b>Cooler Pump Control</b> .....	30	• MINIMUM FLUID LOOP VOLUME	
• NO PUMP CONTROL		• FLOW RATE REQUIREMENTS	
• SINGLE PUMP CONTROL		<b>OPERATION</b> .....	67-74
• DUAL PUMP AND MANUAL CONTROL		<b>Sequence of Operation</b> .....	67
<b>Machine Start Delay</b> .....	31	• ACTUATED BALL VALVE (ABV), FLOODED COOLER ONLY	
<b>Circuit/Compressor Staging and Loading</b> .....	31	<b>Dual Chiller Sequence of Operation</b> .....	68
• CIRCUIT/COMPRESSOR STAGING		• PUMP OPERATION	
• CIRCUIT/COMPRESSOR LOADING		<b>Operating Modes</b> .....	68
<b>Minimum Load Control</b> .....	32	<b>Sensors</b> .....	71
<b>Dual Chiller Control</b> .....	32	• THERMISTORS	
• DUAL CHILLER CONTROL FOR PARALLEL APPLICATIONS		• TRANSDUCERS	
• DUAL CHILLER PUMP CONTROL FOR PARALLEL CHILLER APPLICATIONS			

## CONTENTS (cont)

	Page
<b>SERVICE</b> .....	74-87
<b>Economizer Assembly</b> .....	74
<b>Electronic Expansion Valve (EXV)</b> .....	74
• FLOODED COOLER MAIN EXV CONTROL	
• DX COOLER MAIN EXV CONTROL	
• ECONOMIZER EXV CONTROL	
• EXV TROUBLESHOOTING PROCEDURE	
<b>Compressor Assembly</b> .....	77
• COMPRESSOR OIL SYSTEM	
<b>Flooded Cooler Units</b> .....	79
• FLOODED COOLER SUCTION SERVICE VALVE	
• FLOODED COOLER FREEZE PROTECTION	
• FLOODED COOLER LOW FLUID TEMPERATURE	
• FLOODED COOLER LOSS OF FLUID FLOW PROTECTION	
• FLOODED COOLER TUBE PLUGGING	
• FLOODED COOLER RETUBING	
• FLOODED COOLER TIGHTENING COOLER HEAD BOLTS	
• FLOODED COOLER INSPECTING/CLEANING HEAT EXCHANGERS	
• FLOODED COOLER WATER TREATMENT	
<b>DX Cooler Units</b> .....	82
• DX COOLER SUCTION SERVICE VALVE	
• DX COOLER FREEZE PROTECTION	
• DX COOLER LIQUID FLUID TEMPERATURE	
• DX COOLER LOSS OF FLUID FLOW PROTECTION	
• DX COOLER TUBE PLUGGING	
• DX COOLER RETUBING	
• DX COOLER TIGHTENING COOLER HEAD BOLTS	
• DX COOLER CHILLED WATER FLOW SWITCH	
<b>DX Cooler and Flooded Cooler Units</b> .....	84
• PREPARATION FOR WINTER SHUTDOWN	
<b>Microchannel Heat Exchanger (MCHX) Condenser Coil Maintenance and Cleaning Recommendations</b> .....	85
<b>RTPF Condenser Coil Maintenance and Cleaning Recommendations</b> .....	85
• REMOVE SURFACE LOADED FIBERS	
• PERIODIC CLEAN WATER RINSE	
• ROUTINE CLEANING OF RTPF COIL SURFACES	
<b>Condenser Fans</b> .....	86
<b>Refrigerant Circuit</b> .....	86
• LEAK TESTING	
• REFRIGERANT CHARGE	
<b>Safety Devices</b> .....	87
• COMPRESSOR PROTECTION	
• OIL SEPARATOR HEATERS	
• COOLER PROTECTION	
<b>Relief Devices</b> .....	87
• PRESSURE RELIEF VALVES	
<b>MAINTENANCE</b> .....	87,88
<b>Recommended Maintenance Schedule</b> .....	87
<b>TROUBLESHOOTING</b> .....	88-109
<b>Alarms and Alerts</b> .....	88
• DIAGNOSTIC ALARM CODES AND POSSIBLE CAUSES	
<b>Service Test</b> .....	104
<b>APPENDIX A — TOUCH PILOT™ DISPLAY TABLES</b> .....	110-127
<b>APPENDIX B — NAVIGATOR™ DISPLAY TABLES</b> .....	128-141
<b>APPENDIX C — CCM TABLES</b> .....	142-156
<b>APPENDIX D — 30XA080-500 CPM DIP SWITCH ADDRESSES</b> .....	157-160
<b>APPENDIX E — PIPING AND INSTRUMENTATION</b> .....	161-164

	Page
<b>APPENDIX F — MAINTENANCE SUMMARY AND LOG SHEETS</b> .....	165-167
<b>APPENDIX G — BACNET COMMUNICATIONS OPTION</b> .....	168-178
<b>INDEX</b> .....	179
<b>START-UP CHECKLIST FOR 30XA LIQUID CHILLERS</b> .....	CL-1 to CL-8

## SAFETY CONSIDERATIONS

Installing, starting up, and servicing this equipment can be hazardous due to system pressures, electrical components, and equipment location (roof, elevated structures, etc.). Only trained, qualified installers and service technicians should install, start up, and service this equipment. When working on this equipment, observe precautions in the literature, on tags, stickers, and labels attached to the equipment, and any other safety precautions that apply. Follow all safety codes. Wear safety glasses and work gloves. Use care in handling, rigging, and setting this equipment, and in handling all electrical components.

### WARNING

Electrical shock can cause personal injury and death. Shut off all power to this equipment during installation and service. There may be more than one disconnect switch. Tag all disconnect locations to alert others not to restore power until work is completed.

### WARNING

DO NOT VENT refrigerant relief valves within a building. Outlet from relief valves must be vented in accordance with the latest edition of ANSI/ASHRAE (American National Standards Institute/American Society of Heating, Refrigerating and Air Conditioning Engineers) 15 (Safety Code for Mechanical Refrigeration). The accumulation of refrigerant in an enclosed space can displace oxygen and cause asphyxiation. Provide adequate ventilation in enclosed or low overhead areas. Inhalation of high concentrations of vapor is harmful and may cause heart irregularities, unconsciousness or death. Misuse can be fatal. Vapor is heavier than air and reduces the amount of oxygen available for breathing. Product causes eye and skin irritation. Decomposition products are hazardous.

### WARNING

DO NOT USE TORCH to remove any component. System contains oil and refrigerant under pressure.

To remove a component, wear protective gloves and goggles and proceed as follows:

- a. Shut off electrical power to unit.
- b. Recover refrigerant to relieve all pressure from system using both high-pressure and low pressure ports.
- c. Traces of vapor should be displaced with nitrogen and the work area should be well ventilated. Refrigerant in contact with an open flame produces toxic gases.
- d. Cut component connection tubing with tubing cutter and remove component from unit. Use a pan to catch any oil that may come out of the lines and as a gage for how much oil to add to the system.
- e. Carefully unsweat remaining tubing stubs when necessary. Oil can ignite when exposed to torch flame.

Failure to follow these procedures may result in personal injury or death.

### ⚠ CAUTION

This unit uses a microprocessor-based electronic control system. Do not use jumpers or other tools to short out components, or to bypass or otherwise depart from recommended procedures. Any short-to-ground of the control board or accompanying wiring may destroy the electronic modules or electrical components.

### ⚠ CAUTION

To prevent potential damage to heat exchanger tubes, always run fluid through heat exchanger when adding or removing refrigerant charge. Use appropriate antifreeze solutions in cooler fluid loop to prevent the freezing of heat exchanger or interconnecting piping when the equipment is exposed to temperatures below 32 F (0° C). Proof of flow switch is factory installed on all models. Do NOT remove power from this chiller during winter shut down periods without taking precaution to remove all water from heat exchanger. Failure to properly protect the system from freezing may constitute abuse and may void warranty.

### ⚠ CAUTION

Compressors require specific rotation. Test condenser fan(s) first to ensure proper phasing. Swap any two incoming power leads to correct condenser fan rotation before starting compressors. Operating the unit without testing the condenser fan(s) for proper phasing could result in equipment damage.

### ⚠ CAUTION

DO NOT re-use compressor oil or any oil that has been exposed to the atmosphere. Dispose of oil per local codes and regulations. DO NOT leave refrigerant system open to air any longer than the actual time required to service the equipment. Seal circuits being serviced and charge with dry nitrogen to prevent oil contamination when timely repairs cannot be completed. Failure to follow these procedures may result in damage to equipment.

## GENERAL

This publication contains Controls, Operation, Start-Up, Service and Troubleshooting information for the 30XA080-500 air-cooled liquid chillers with electronic controls. The 30XA chillers are equipped with *ComfortLink*<sup>™</sup> controls and electronic expansion valves. The AquaForce<sup>®</sup> 30XA chillers offer two different user interface devices, the Touch Pilot<sup>™</sup> display and the Navigator<sup>™</sup> display.

**Conventions Used in This Manual** — The following conventions for discussing configuration points for the Navigator module and Touch Pilot display will be used in this manual.

Point names for the Touch Pilot display will be shown in **bold**. See Appendix A for a complete list of point names. Item names for the Navigator module will be shown in *bold italics*. See Appendix B for the complete path name preceding the item name. The point and item names in Appendices A and B will be listed in alphabetical order and the path name for each will be written with the mode name first, then any sub-modes, each separated by an arrow symbol (→).

This path name will show the user how to navigate through the Navigator module or the Touch Pilot display to reach the desired

configuration. The user would scroll through the modes and sub-modes using the ▲ and ▼ keys on the Navigator display. For the Touch Pilot display, the user would simply touch the menu item on the screen. The arrow symbol in the path name represents pressing **ENTER** to move into the next level of the menu structure for the Navigator module, or touching the menu item on the screen for the Touch Pilot display.

When a value is included as part of the point name, it will be shown after the point name after an equals sign. If the value represents a configuration setting, an explanation will be shown in parentheses after the value. The Touch Pilot name will be shown first with the Navigator name following. As an example,

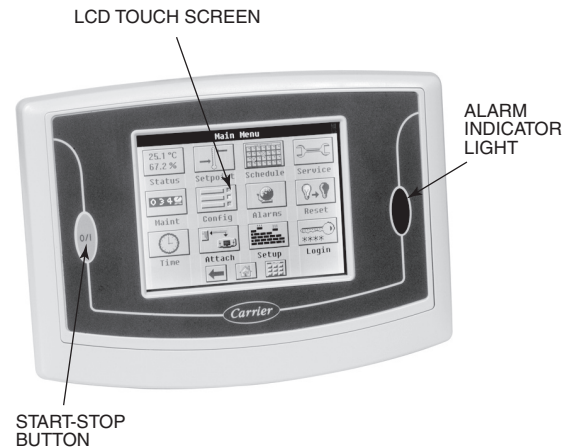
**(Staged Loading Sequence = 1, LLCS = Circuit A leads).**

Press the **ESCAPE** and **ENTER** keys simultaneously on the Navigator module to display an expanded text description of the point name or value. The expanded description is shown in the Navigator display tables (Appendix B) but will not be shown with the path names in text. The Touch Pilot display will show an expanded description of the point name. To view the expanded point name for the Touch Pilot display go to Appendix A.

The Touch Pilot display configures the unit via the CCN (Carrier Comfort Network<sup>®</sup>) Tables, which are located in Appendix C of this manual.

## Display Module Usage

**TOUCH PILOT DISPLAY** — The Touch Pilot display is the standard user interface for the AquaForce 30XA chillers with the *ComfortLink* control system. The display includes a large LCD (liquid crystal display) touch screen for display and user configuration, a Start/Stop button, and an Alarm Indicator LED (light-emitting diode). See Fig. 1.



**Fig. 1 — Touch Pilot<sup>™</sup> Display**


The Touch Pilot display can be used to access various Carrier Comfort Network<sup>®</sup> devices. For operation under these circumstances, contact your Carrier representative.


Operation of the Touch Pilot display is driven from the displays on the touch screen. The Touch Pilot display uses the following screen “buttons” to allow the user to operate the display and navigate within and between screens.


← “BACK” Returns to the next higher screen in the hierarchy.


🏠 “HOME” Displays the Default Group Display screen for Touch Pilot display. The Default Screen is a user-configured display of up to 9 points on each of 8 screens. This allows for quick access to various, frequently viewed points, without navigating through the Main Menu structure. This button is available at all menu levels and returns the user to the first Default Group Display screen.





 “MAIN MENU” Displays the Main Menu screen. This allows access for viewing and configuration, where possible, of all points supported by the controller. This includes points such as set point and operational configuration. This button is available at all menu levels and returns the user to the Main Menu screen.


 “PREVIOUS” In a group of sequential screens of the same type, pressing this button moves the user to the next earlier screen in the group.


 “NEXT” In a group of sequential screens of the same type, pressing this button advances the user to the next screen in the group.


 “OK” Agrees with, or says “yes” to a prompt and performs the appropriate processing.


 “NO” Rejects, or says “no” to a prompt and performs the appropriate processing.


 “CANCEL” Terminates an ongoing action and returns to the current screen without any other processing.


 “CLEAR DATA” Clears the data value in a data entry dialog box. This button is used to clear incorrect data.


 “RESET DATA” Zeros the data value in a data entry dialog box.


 “ADD” Adds the active point to a Group Display screen.


 “REMOVE” Deletes a point from a Group Display screen.


 “INCREASE” Modifies the value of a field within its defined limits or “SCROLL UP” and shifts the screen view up by one item.


 “DECREASE” Modifies the value of a field within its defined limits or “SCROLL DOWN” and shifts the screen view down by one item.


 “PAGE DOWN” If the current table or list has more data than will fit on the screen, pressing this button will replace the items currently on the screen with the next group of items.


 “PAGE UP” If the current table or list has more data than will fit on the screen, pressing this button will replace the items currently on the screen with the previous group of items.

 “FORCE” Begins the process of forcing or overriding the value of a point.

 “AUTO” Begins the process of removing a force from a point.

 “MODIFY” Begins the process of modifying a configuration value.

 “ALARM INDICATOR LIGHT” An LED alarm indicator light is activated when a new alarm condition occurs. The alarm indicator light, located on the right side of the display, remains activated until it is manually reset using the Reset button on the Main menu.


 “START/STOP BUTTON” The Touch Pilot™ display includes an equipment Start/Stop Button that enables the user to start or stop the chiller from the display. See Enable-Off-Remote Contact Switch (SW1) on page 17 for additional information.


Several items are password protected. When required, a Password dialog box will be displayed for field input of the password. The default password is 3333. The password can be changed if desired.

**Power-Up Display** — When the Touch Pilot display is powered up, it displays an initialization progress bar and attaches (initiates communication) to the Main Base Board. The Touch Pilot display then shows that controller’s default Group Display screen. See Fig. 2. This is a user-configured display screen

with up to 9 points on 8 separate screens. For more information on adding or removing points from the Group Display screen, see the Group Display Screens section on page 6.

Touch any of the screen point buttons and Point Data Dialog box will be displayed with expanded information. In the example shown below, the CTRL\_PNT button in the bottom left corner was selected. See Fig. 2 and 3.

To exit the box, press .

**Main Menu Display** — The default screen for the Touch Pilot controller is the Group Display screen. To access the Main Menu, press the  button. The screen shown in Fig. 4 will be displayed. Selecting a button will display the screens associated with that category. The user can also access the login screen from the Main Menu if needed.

**Touch Pilot Menu Structure** — The user can navigate through the Touch Pilot display screens by selecting the buttons that appear on the screen. When a button is selected, either a submenu or a list of point names and values will be shown. Submenus will display a list of associated point names. See Fig. 5 for the Touch Pilot menu structure.

If the list of point names and values are shown, the top line of the display is the table name. The line and total line counter is displayed in the upper right corner of the display. Selecting an item will cause a Point Data dialog box to appear.

**Setup Menu Screen** — The Setup Menu screen, shown in Fig. 6, is accessed by pressing the Setup button from the Main Menu. This configuration allows the user to configure the basic operation and look of the display. Table 1 summarizes the Setup Menu functions.

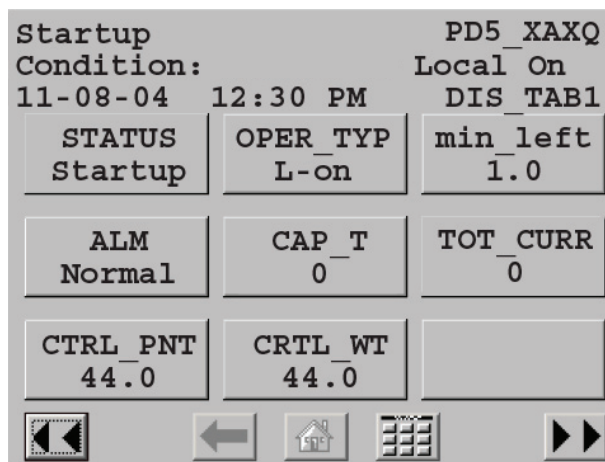


Fig. 2 — Group Display Screen

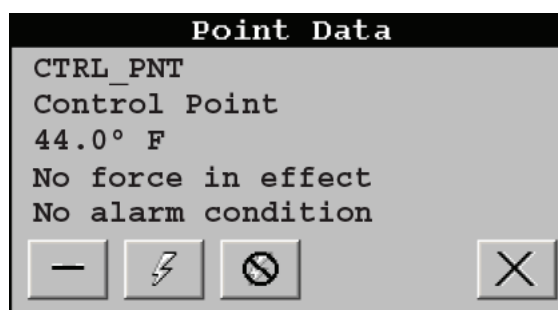


Fig. 3 — Point Data Dialog Box



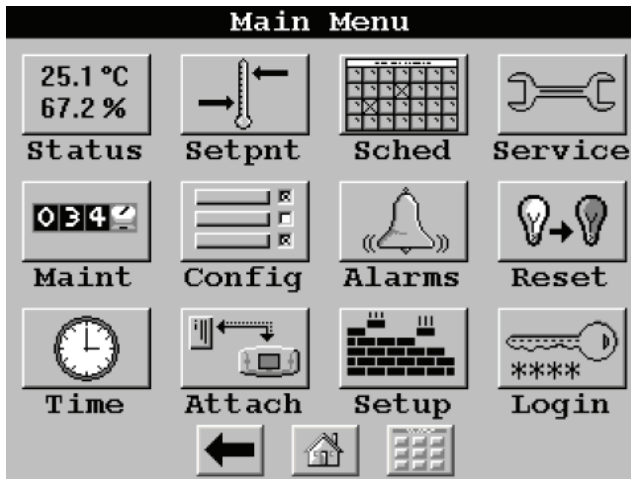


Fig. 4 — Main Menu Display



Fig. 6 — Setup Menu Display

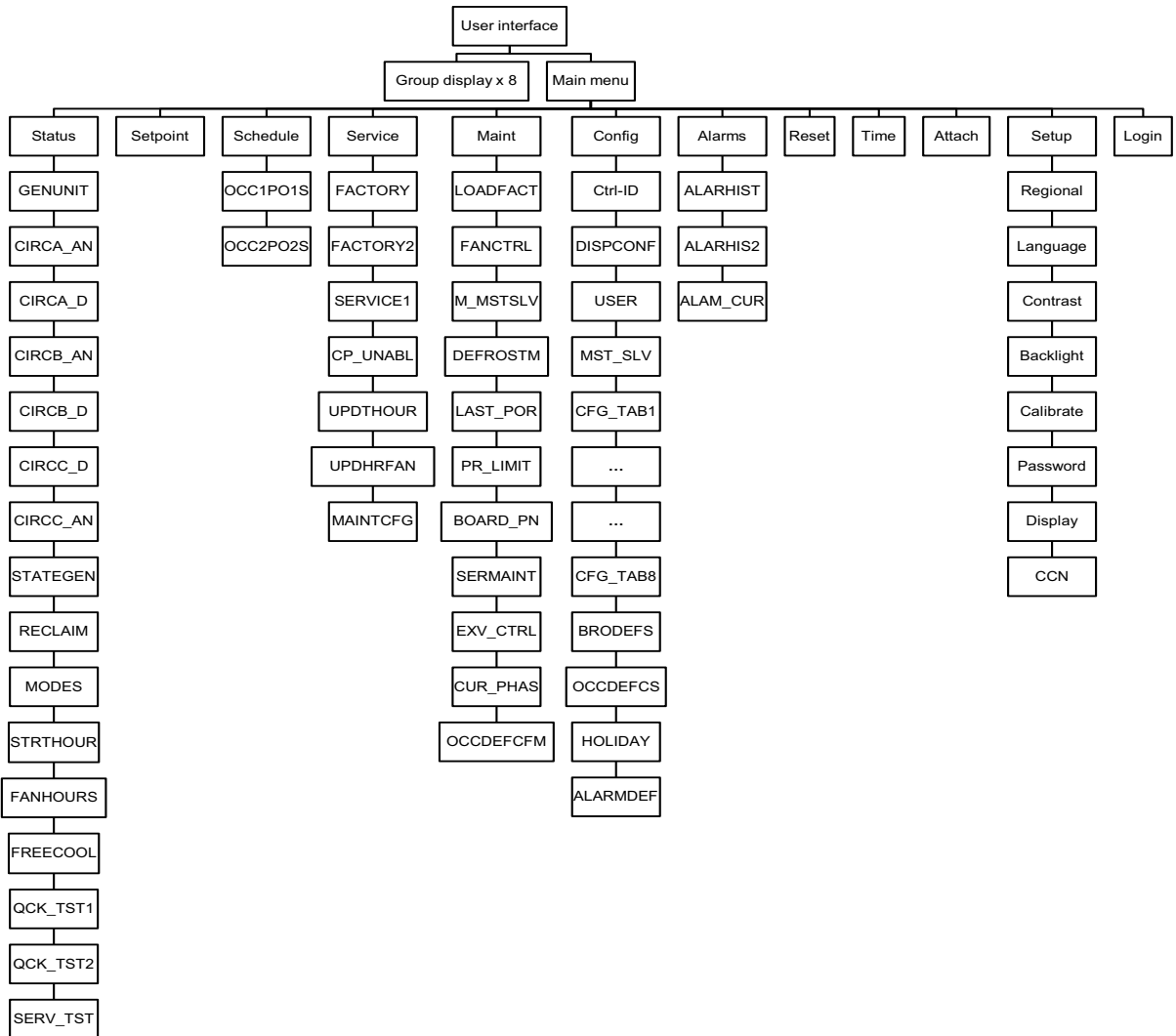
















Fig. 5 — Touch Pilot™ Display Menu Structure

**Table 1 — Setup Menu**

SETUP MENU BUTTON	FUNCTION
<b>REGIONAL</b>	This button specifies the time and date format and the base unit of measure. Time display can be configured as 12-hour AM/PM setting or as a 24-hour setting. The date can be formatted in one of 3 settings, MM-DD-YYYY (Month-Day-Year), DD-MM-YYYY (Day-Month-Year), or YYYY-MM-DD (Year-Month-Day). Units of measure can be either US (English) or Metric (SI).
<b>LANGUAGE</b>	This button selects the active language and font of the display. Available languages are English and Spanish (Español). If a preferred language is not available, additional software for the Main Base Board (MBB) and the Touch Pilot™ display are required. Contact your Carrier representative for instructions and software.
<b>CONTRAST</b>	This button adjusts the LCD contrast. Press and hold the [MOON] button to increase/darken the contrast or the [STAR] button to decrease/lighten the current contrast. NOTE: Touching the screen anywhere for 5 seconds while powering-up will prompt the user to restore contrast and calibration settings to factory defaults.
<b>BACKLIGHT</b>	This button specifies whether backlighting should be kept on at all times or turned off during inactive periods.
<b>CALIBRATE</b>	This button is used to adjust the LCD touch screen calibration. Touch the screen in the circular targets located first in the upper left and then in the lower right corner of the screen to adjust.
<b>PASSWORDS</b>	This button is used to configure the limited and full logged-in access system passwords. In order to change passwords, the user must be logged in with full access to view and change the passwords. All passwords must consist of 4-digits, which can be entered using the numeric keypad. Access levels and associated privileges are as follows:  Limited Logged-in Access - Provides the user with read/write access to all available tables (except service configuration tables, where the user will not be permitted to modify point data, and Group Display tables, where the user will not be permitted to add points.) This access level also provides read/write access to all Touch Pilot display setup properties except Display, CCN, and Password.  Full Logged-in Access - Provides user with read/write access to all available tables for the attached device and all Touch Pilot display properties.  If the user does not log in, read-only access to all tables is allowed. The user will be prompted to log in when attempting to access password-required functions.
<b>DISPLAY</b>	This button is used to view the description data and part number from the Ctr-ID Table and to specify the Operating Mode. The Operating mode can be configured for Equipment mode or Network mode. For Touch Pilot displays that are standard with the unit, Operating mode should not be changed from Equipment mode. Equipment mode provides access only to the chiller's MBB via the Local Equipment Network (LEN) Bus. For remote access, a remote Touch Pilot display can be set to Network mode. Network mode provides access to all devices on the CCN (Carrier Comfort Network®) bus.  NOTE: When changing the operating mode, a power cycle is required in order for the new operating mode to take effect. The user should view and correct the following CCN data: address and baud rate, alarm acknowledger, and broadcast acknowledger designation.
<b>CCN</b>	This button is used to configure the bus and element numbers and the baud rate of the control on the network.

**Setting the Time and Date** — The *ComfortLink™* control has a time and date function. This can be useful for diagnostics to determine when alarms occur. The control is factory configured for the proper date and is set for the Eastern Time Zone. The date and time zone must be checked and corrected if necessary, to allow the machine to function on an internal time schedule and to display a proper time and date stamp for alarms. The time and date is displayed on the Group Display Screen.

To change the Time and Date, press the  Main Menu button. Select  Time. On the display, a day and date box with a time box will be shown. To change the day and date, press the day and date box. A calendar will be displayed. If the correct month is displayed, touch the correct date. If the wrong month is displayed, use the  or  to change to the correct month and select the correct date. The date will be highlighted. Press  to accept the change. The previous screen will be displayed with the corrected day and date shown. To correct the time, use the  or  on the left to change the hour. Use the  or  on the left to change the minutes. Continuously touching the  or  will sequence the numbers. The time is shown in a 24-hour format. To accept the changes, press the  or  buttons. A “Save” dialog box is displayed with the words, “Do you wish to save changes?” Press  to accept the changes.

**Group Display Screens** — The Touch Pilot™ display supports up to eight Group Display screens. Group Display screens show status information along the top of the screens and nine buttons that display nine point names and point values that are chosen by the user. All Group Display screen points are user configurable. The bottom line of the screen contains navigation buttons that can be used to move between the Group Display screens.

Pressing a point button will show that point's Point Data dialog box. See Fig. 2 and 3. This box contains buttons that remove the point from the group display and apply or remove a force (point override). When touching any button in the display screen, the button will be outlined to acknowledge input. There may be a delay in response to input, but if the button is outlined, do NOT press any other button until the previous input has been processed.

If there is a communication failure with the MBB (Main Base Board), all point buttons will be displayed in inverse video and the message *Communication Failure* will be displayed in the top left line of the screen.

**Default Group Designation** — The default group is the first of the 8 Group Display screens. This is the default screen of the display. Information on this screen as well as the other 7 screens can be user-modified to meet the needs of the site.

**To Add a Point To a Group Display** — From the Main Menu, press the desired menu button (Status, Setpoint, Service, Maint, or Config) and, if necessary, the sub-menu button to access the point to be added. Press the point button to show the source point's Point Data dialog box. See Fig. 3. From the Point Data dialog box, press the ADD button. The display will show the last Group Display accessed. Use the navigation buttons to access the destination Group Display. Press an existing

point button or a blank button to update the highlighted button with the source point's name. Press to add the highlighted point to the group and return to the table display.

*To Remove a Point From a Group Display* — From the Point Data Dialog box, press the REMOVE button and follow the prompts. The display will return to the Group Display screen from which the point was removed, and the button corresponding to the deleted point will be blank and disabled.

NAVIGATOR™ DISPLAY MODULE — The Navigator display module provides a mobile user interface to the ComfortLink control system. The display has up and down arrow keys, an **ENTER** key, and an **ESCAPE** key. These keys are used to navigate through the different levels of the display structure. Press the **ESCAPE** key until 'Select a Menu Item' is displayed. Use the up and down arrow keys to move through the top 11 mode levels indicated by LEDs on the left side of the display. See Fig. 7. See Table 2 and Appendix B for more details about the display menu structure.

Once within a mode or sub-mode, a "<>" indicates the currently selected item on the display screen. Pressing the **ENTER** and **ESCAPE** keys simultaneously will put the Navigator module into expanded text mode where the full meaning of all sub-modes, items, and their values can be displayed. Pressing the **ENTER** and **ESCAPE** keys when the display says 'Select Menu Item' (Mode LED level) will return the Navigator module to its default menu of rotating display items (those items in *Run Status*→VIEW). In addition, the password will be disabled, requiring that it be entered again before changes can be made to password protected items. Press the **ESCAPE** key to exit out of the expanded text mode.

When a specific item is located, the item name appears on the left of the display, the value will appear near the middle of the display and the units (if any) will appear on the far right of the display. Press the **ENTER** key at a changeable item and the value will begin to flash. Use the up and down arrow keys to change the value, and confirm the value by pressing the **ENTER** key.

Changing item values or testing outputs is accomplished in the same manner. Locate and display the desired item. Press **ENTER** so that the item value flashes. Use the arrow keys to change the value or state and press the **ENTER** key to accept it. Press the **ESCAPE** key to return to the next higher level of structure. Repeat the process as required for other items.

Items in the Configuration and Service Test modes are password protected. The words **Enter Password** will be displayed when required, with 1111 also being displayed. The default password is 0111. Use the arrow keys to change each number and press **ENTER** to accept the digit. Continue with the remaining digits of the password. The password can only be changed through CCN operator interface software such as ComfortWORKS®, ComfortVIEW™ and Service Tool.

**Power-Up Display** — When the Navigator display is powered up it will display:

ComfortLink  
Navigator  
By  
Carrier

This indicates an initialization period while the Navigator™ display initiates communication with the Main Base Board. Once communication is established, the default rotating

display will be shown. If communication is not established, the Navigator module will display:

Communication  
Failure

If the Navigator module is connected to a Main Base Board without software loaded, the display will remain at the powered-up initialization display.

**Setting the Time and Date** — The ComfortLink control has a time and date function. This can be useful for diagnostics to determine when alarms occur. The control is factory configured for the proper date and for use in the Eastern Time Zone. The control must be checked and corrected if necessary. The correct time is important if the machine is to function on an internal time schedule and display a proper time and date stamp for alarms. The time and date will be displayed on the default rotating display of the Navigator module. The time and date can also be checked and changed under the Time Clock mode as described below.

ITEM	ITEM EXPANSION	PATH	VALUE
HH.MM	Time of Day	Time Clock→TIME	XX.XX

To change the time, press the arrow key to move to the correct hour and press **ENTER**. The minutes can be changed in a similar manner.

To check or change the date, the following items must be checked and changed if necessary.

ITEM	ITEM EXPANSION	PATH	VALUE
MNTH	Month of Year	Time Clock→DATE	WW
DOM	Day of Month	Time Clock→DATE	XX
DAY	Day of Week	Time Clock→DATE	YY
YEAR	Year of Century	Time Clock→DATE	ZZ

NOTE: WW is the current month of the controller, (01=January, 02=February, etc.).

XX is the current day of the month

YY is the day of the week, (01=Monday, 02=Tuesday, etc.)

ZZ is the year of the century, (06=2006, 07=2007)

**Changing the Unit of Measure** — The Navigator display has two options for unit of measure on the display, English or SI (metric). The factory default for the units of measure is English. To change the unit of measure, the following item must be changed.

ITEM	ITEM EXPANSION	PATH	VALUE
METR	Metric Display	Configuration→DISP	OFF – English ON – SI (Metric)



**Fig. 7 — Navigator Display Module**



**Table 2 — ComfortLink™ Navigator™ Display Menu Structure**

MODE										
RUN STATUS	SERVICE TEST	TEMPERATURES	PRESSURES	SET POINTS	INPUTS	OUTPUTS	CONFIGURATION	TIME CLOCK	OPERATING MODES	ALARMS
Auto Display (VIEW)	Manual Test Mode (TEST)	Unit Temperatures (UNIT)	Circuit A Pressures (PRC.A)	Cooling Setpoints (COOL)	General Inputs (GEN.I)	Circuit A Outputs (CIR.A)	Display Configuration (DISP)	Time of Day (TIME)	Operating Control Type (SLCT)	Reset Current Alarms (R.ALM)
Machine Starts/Hours (RUN)	Quick Test Mode (QUIC)	Circuit A Temperatures (CIR.A)	Circuit B Pressures (PRC.B)	Heating Setpoints (HEAT)		Circuit B Outputs (CIR.B)	Unit Configuration (UNIT)	Day, Date (DATE)	Operating Modes (MODE)	Current Alarms (ALRM)
Compressor Run Hours (HOUR)		Circuit B Temperatures (CIR.B)	Circuit C Pressures (PRC.C)	Misc. Setpoints (MISC)		Circuit C Outputs (CIR.C)	Service Configurations (SERV)	Schedule 1 (SCH1)		Alarm History (H.ALM)
Compressor Starts (STRT)		Circuit C Temperatures (CIR.C)				General Outputs (GEN.O)	Options Configuration (OPTN)	Schedule 2 (SCH2)		
Fan Run Hours (FAN)							Reset, Demand Limit, Master/Slave (RSET)	Holidays (HOLI)		
Compressor Disable (CP.UN)								Service Maintenance Configuration (MCFG)		
Predictive Maintenance (MAIN)										
Software Versions (VERS)										

**Changing the Display Language** — The Navigator display has five language options to select from, English, Espanol, Francais, Portugues, and Translated. The “Translated” option is not supported at this time. The factory default language is English. To change the display language, the following item must be changed.

ITEM	ITEM EXPANSION	PATH	VALUE
LANG	Language Selection	Configuration→DISP	English Espanol Francais Portugues Translated

NOTE: When the Language Selection (**Configuration** →**DISP**→**LANG**) variable is changed, all appropriate display expansions will immediately change to the new language. The four letter/digit code will not change. No power-off or control reset is required when reconfiguring languages.

**Adjusting the Contrast** — The contrast of the display can be adjusted to suit ambient conditions. To adjust the contrast, enter the LED Test mode of the device.

ITEM	ITEM EXPANSION	PATH	VALUE
TEST	Test Display LEDs	Configuration→DISP	

Pressing **[ENTER]** will access the TEST point. Pressing **[ENTER]** again will cause the “OFF” to flash. Use the up or down arrow to change “OFF” to “ON.” Pressing **[ENTER]** will illuminate all LEDs and display all pixels in the view screen. Pressing **[ENTER]** and **[ESCAPE]** simultaneously allows the user to adjust the display contrast. The display will read:

Adjust Contrast  
-----+-----

Use the up or down arrows to adjust the contrast. The screen’s contrast will change with the adjustment. Press **[ENTER]** to accept the change. The Navigator module will keep this setting as long as it is plugged in to the LEN (Local Equipment Network) bus.

**Adjusting the Backlight Brightness** — The backlight of the display can be adjusted to suit ambient conditions. The factory

default is set to the highest level. To adjust the backlight of the Navigator module, enter the LED Test mode of the device.

ITEM	ITEM EXPANSION	PATH	VALUE
TEST	Test Display LEDs	Configuration Mode→DISP	

Pressing **[ENTER]** will access the TEST point. Pressing **[ENTER]** again will cause the “OFF” to flash. Use the up or down arrow to change “OFF” to “ON.” Pressing **[ENTER]** will illuminate all LEDs and display all pixels in the view screen. Pressing the up and down arrow keys simultaneously allows the user to adjust the display brightness. The display will read:

Adjust Brightness  
-----+-----

Use the up or down arrow keys to adjust screen brightness. Press **[ENTER]** to accept the change. The Navigator module will keep this setting as long as it is plugged in to the LEN bus.

## CONTROLS

**General** — The 30XA air-cooled liquid chillers contain the ComfortLink™ electronic control system that controls and monitors all operations of the chiller. The control system is composed of several components as listed in the following sections. All machines have a Main Base Board (MBB), Touch Pilot™ module, electronic expansion valve board (EXV), fan board, Compressor Protection board, Emergency On/Off switch, and an Enable-Off-Remote Contact switch.

**Main Base Board (MBB)** — The MBB is the core of the ComfortLink control system. It contains the major portion of operating software and controls the operation of the machine. See Fig. 8. The MBB continuously monitors input/output channel information received from its inputs and from all other modules. The MBB receives inputs from status and feedback switches, pressure transducers and thermistors. The MBB also controls several outputs. Some inputs and outputs that control the chiller are located on other boards, but are transmitted to or from the MBB via the internal communications bus. Information is transmitted between modules via a 3-wire communication bus or LEN (Local Equipment Network). The CCN (Carrier Comfort Network®) bus is also supported. Connections to both LEN and CCN buses are made at TB3.

For a complete description of Main Base Board inputs and outputs and their channel identifications, see Table 3.

**Compressor Protection Module (CPM)** — There is one CPM per compressor. See Fig. 9. The device controls the compressor contactors, oil solenoid, loading/unloading the solenoid, motor cooling solenoid (30XA080,082 only) and the oil separator heater. The CPM also monitors the compressor motor temperature, high pressure switch, oil level switch, discharge gas temperature, oil pressure transducer, motor current, MTA (must trip amps) setting and economizer pressure transducer. The CPM responds to commands from the MBB (Main Base Board) and sends the MBB the results of the channels it monitors via the LEN (Local Equipment Network). The CPM has three DIP switch input banks, Switch 1 (S1), Switch 2 (S2), and Switch 3 (S3). The CPM board DIP switch (S1) configures the board for the type of starter, the location and type of the current transformers and contactor failure instructions. See Table 4 for description of DIP switch 1 (S1) inputs. See Appendix D for DIP switch settings.

The CPM board DIP switch S2 setting determines the must trip amps (MTA) setting. See Appendix D for DIP switch settings. The MTA setting which is calculated using the settings S2 must match the MTA setting in the software or an MTA alarm will be generated.

See below for CPM board DIP switch S3 address information. See Table 5 for CPM inputs and outputs.

CPM-A DIP Switch	1	2	3	4
Address:	OFF	OFF	OFF	OFF
CPM-B DIP Switch	1	2	3	4
Address:	OFF	OFF	ON	OFF
CPM-C DIP Switch	1	2	3	4
Address:	OFF	OFF	OFF	ON

NOTE: The CPM-A and CPM-B DIP switches are for all units. The CPM-C DIP switches are for 30XA400-500 units.

**Electronic Expansion Valve (EXV) Board** —

The 30XA080,082 unit has one EXV board. The 30XA090-500 units have one EXV board per circuit. See Fig. 10. The board is responsible for monitoring the suction gas temperature and economizer gas temperature thermistors. The board also signals the main EXV and economizer EXV (ECEXV) motors to open or close. The electronic expansion valve board responds to commands from the MBB and sends the MBB the results of the channels it monitors via the LEN (Local Equipment Network). See below for DIP switch information. See Tables 6 and 7 for EXV inputs and outputs.

EXV BOARD A (080-500) DIP SWITCH	1	2	3	4	5	6	7	8
Address:	ON	ON	ON	ON	ON	ON	OFF	ON
EXV BOARD B (090-500) DIP SWITCH	1	2	3	4	5	6	7	8
Address:	OFF	ON	ON	ON	ON	ON	OFF	ON
EXV BOARD C (400-500) DIP SWITCH	1	2	3	4	5	6	7	8
Address:	ON	OFF	ON	ON	ON	ON	OFF	ON

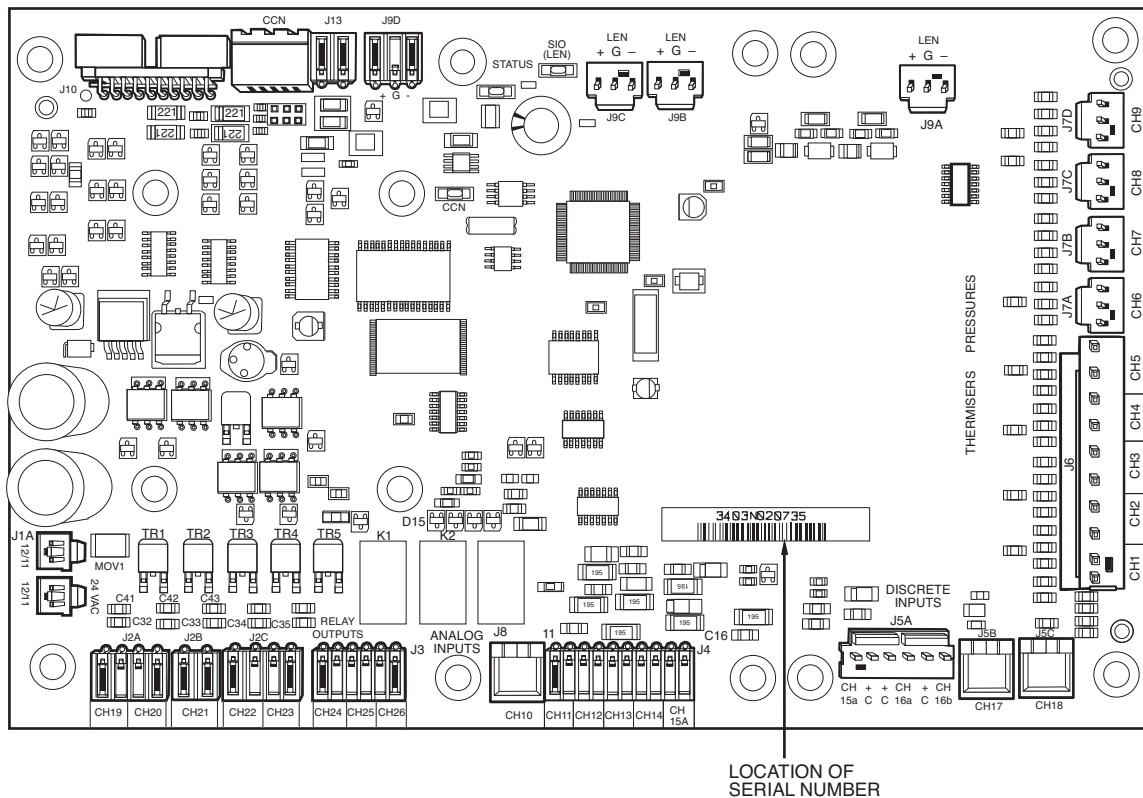


Fig. 8 — Main Base Board

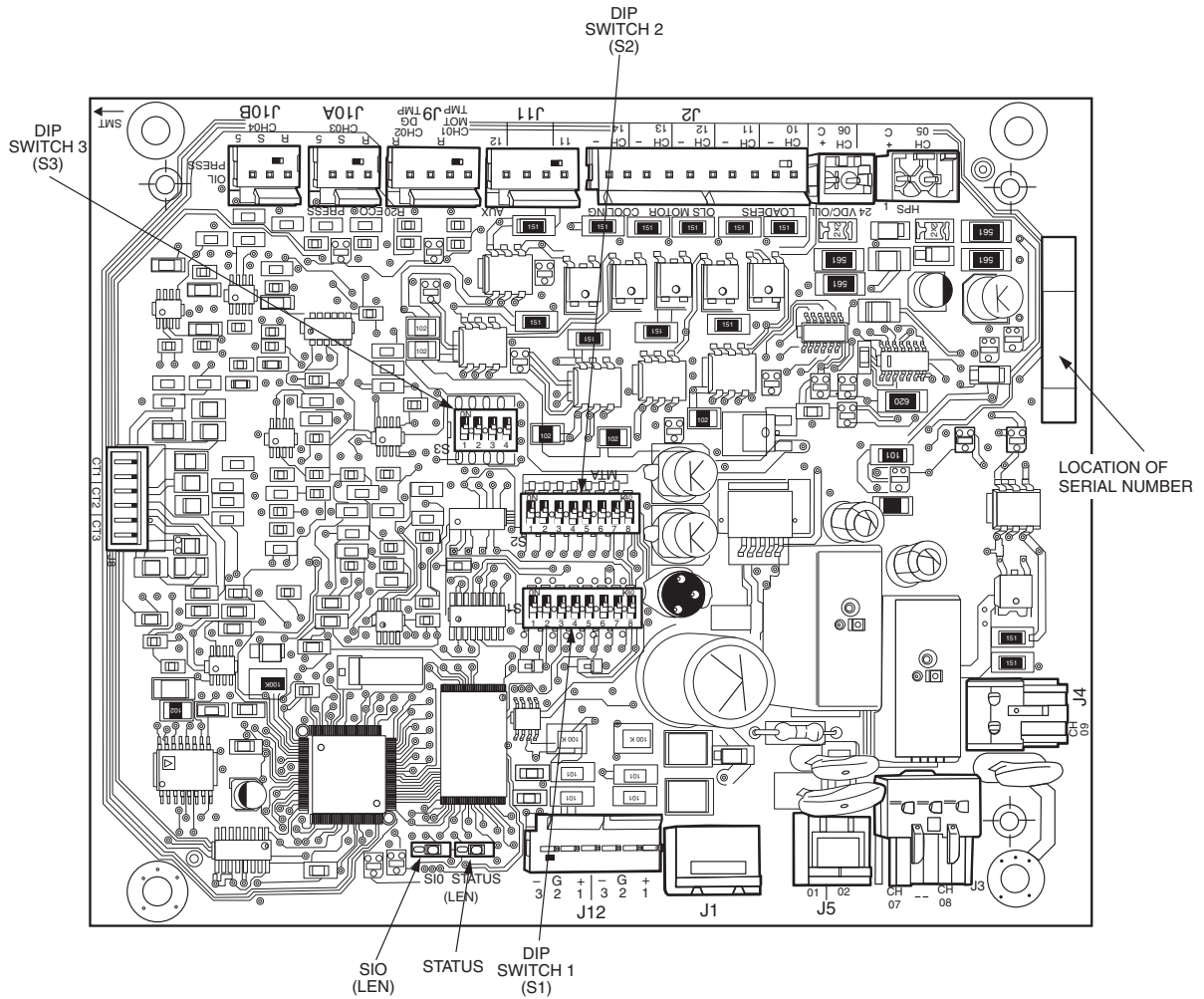
**Table 3 — Main Base Board Inputs and Outputs**

DESCRIPTION	INPUT/OUTPUT	I/O TYPE	DISPLAY MODULE POINT NAME	CONNECTION POINT	
				Pin	Notation
Power (24 vac supply)	—	—	—	MBB-J1, MBB-J1A, MBB-J1B	
				11	24 vac
				12	Ground
Local Equipment Network	—	—	—	MBB-J9A, MBB-J9B, MBB-J9C, MBBJ9D	
				+	RS485 Port (D+)
				G	RS485 Port (Gnd)
Carrier Communication Network	—	—	—	MBB-J12	
				+	RS485 Port (D+)
				G	RS485 Port (Gnd)
Chilled Water Flow Switch	CWFS	Switch	Cooler Flow Switch, <i>LOCK</i>	MBB-J5B-CH17	
				17	
Demand Limit Switch No. 1	Demand Limit SW1	Switch	Limit Switch 2 Status, <i>DLS1</i>	MBB-J4-CH13	
Circuit A Discharge Pressure Transducer	DPTA	Pressure Transducer	Discharge Pressure, <i>DP.A</i>	MBB-J7A-CH6	
				5V	+5 vdc Ref.
				S	Signal
				R	Return
Circuit B Discharge Pressure Transducer	DPTB	Pressure Transducer	Discharge Pressure, <i>DP.B</i>	MBB-J7C-CH8	
				5V	+5 vdc Ref.
				S	Signal
				R	Return
Dual Chiller LWT Thermistor	DUAL	5k Thermistor	CHWS Temperature, <i>CHWS</i>	MBB-J6-CH3	
Dual Set Point Input	Dual Set Point	Switch	Remote Setpoint Switch, <i>DUAL</i>	MBB-J4-CH12	
Entering Water Thermistor	EWT	5k Thermistor	Cooler Entering Fluid, <i>EWT</i>	MBB-J6-CH2	
Leaving Water Thermistor	LWT	5k Thermistor	Cooler Leaving Fluid, <i>LWT</i>	MBB-J6-CH1	
Outdoor Air Thermistor	OAT	5k Thermistor	External Temperature, <i>OAT</i>	MBB-J6-CH4	
External Chilled Water Pump Interlock	PMP1	Switch	Electrical Box Interlock, <i>ELEC</i>	MBB-J4-CH15A	
Circuit A Suction Pressure Transducer	SPTA	Pressure Transducer	Suction Pressure, <i>SP.A</i>	MBB-J7B-CH7	
				5V	+5 vdc Ref.
				S	Signal
Circuit B Suction Pressure Transducer	SPTB	Pressure Transducer	Suction Pressure, <i>SP.B</i>	MBB-J7D-CH9	
				5V	+5 vdc Ref.
				S	Signal
Unit Status	Remote Contact-Off-Enable	Switch	On/Off Remote Switch, <i>ONOF</i>	MBB-J4-CH11	
Alarm Relay	ALM R	Relay	Alarm Relay Output, <i>ALRM</i>	MBB-J3-CH24	
Alert Relay	ALT R	Relay	Alert Relay Output, <i>ALRT</i>	MBB-J3-CH25	
Cooler Heater	CL-HT	Contactactor	Cooler Heater Command, <i>CO.HT</i>	MBB-J3-CH26	
Isolation Valve A	ISVA	Contactactor	Ball Valve Position, <i>BVL.A</i>	MBB-J2A-CH19	
Isolation Valve B	ISVB	Contactactor	Ball Valve Position, <i>BVL.B</i>	MBB-J2A-CH20	
Isolation Valve C (Size 400-500)	ISVC	Contactactor	Ball Valve Position, <i>BVL.C</i>	MBB-J2C-CH22	
Oil Heater A (Size 080, 082 only)	OIL HT_A	Contactactor	Circuit A Oil Heater, <i>HT.A</i>	MBB-J2C-CH22	
Oil Heater B (Size 080, 082 only)	OIL HT_A	Contactactor	Circuit B Oil Heater, <i>HT.B</i>	MBB-J2C-CH23	
Pump #1 Interlock Pump #2 Interlock	PMP1 PMP2	Switch	Cooler Pump Run Status, <i>PUMP</i>	MBB-J5C-CH18	

LEGEND

I/O — Input or Output  
LWT — Leaving Water Temperature





**Fig. 9 — Compressor Protection Module**

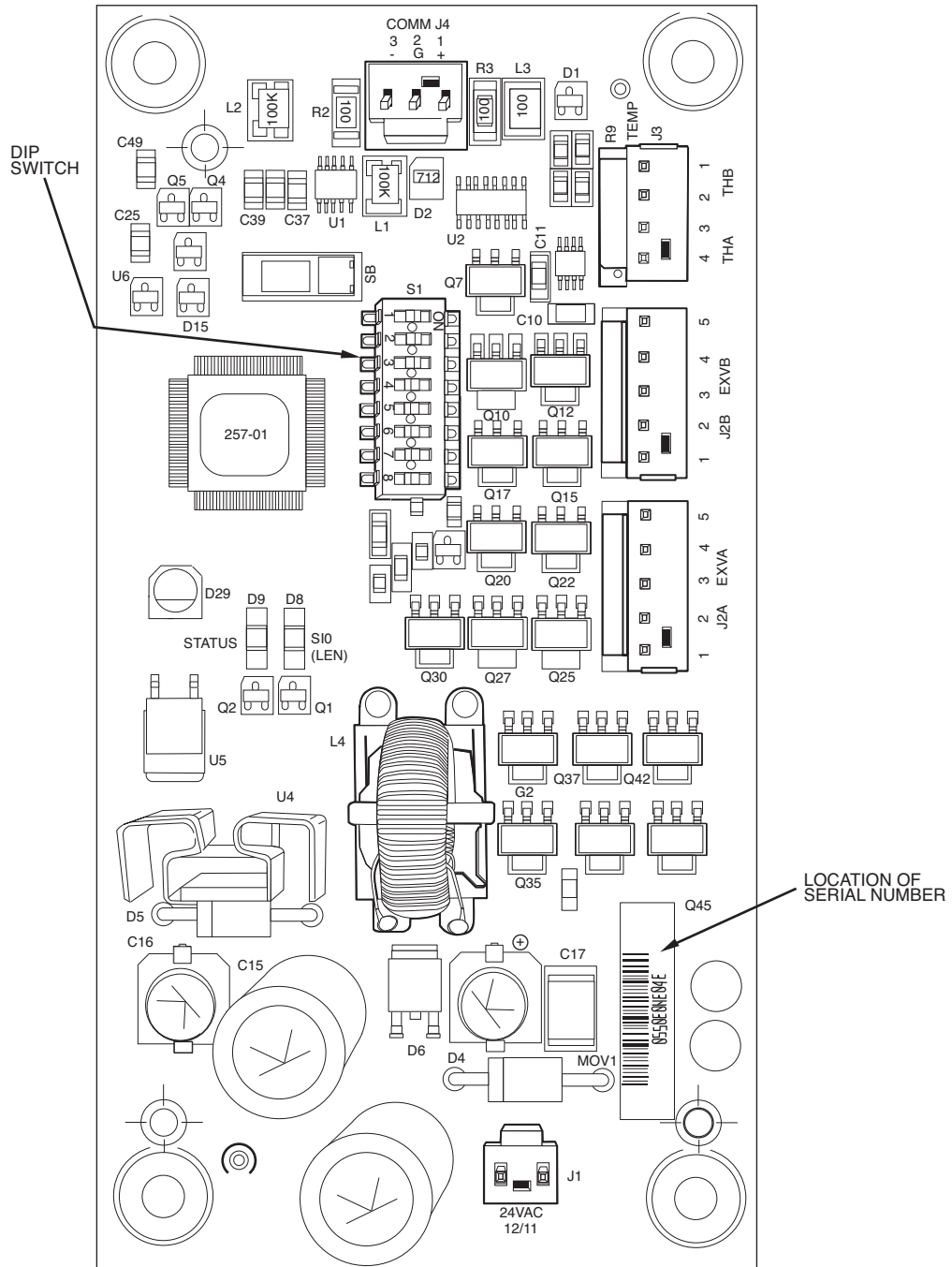
**Table 4 — DIP Switch 1 (S1) Inputs**

DIP SWITCH POSITION	FUNCTION	SETTING	MEANING
1	Starter Configuration	OFF	Across-the-line Start
		ON	Wye-Delta Start
2, 3	Current Transformer (CT) Position	OFF (2), OFF (3)	CT is located in the Delta of the motor
		ON (2), OFF (3)	CT is located in the main line
		OFF (2), ON (3)	Reserved for future use
		ON (2), ON (3)	Invalid; will cause MTA configuration alarm
4, 5, 6	Current Transformer (CT) Selection	OFF (4), OFF (5), OFF (6)	100A/1V CT1
		ON (4), OFF (5), OFF (6)	100A/0.503V CT2
		OFF (4), ON (5), OFF (6)	100A/0.16V CT3
		ON (4), ON (5), OFF (6)	Invalid; will cause MTA configuration alarm
		OFF (4), OFF (5), ON (6)	Invalid; will cause MTA configuration alarm
		ON (4), OFF (5), ON (6)	Invalid; will cause MTA configuration alarm
		OFF (4), ON (5), ON (6)	Invalid; will cause MTA configuration alarm
		ON (4), ON (5), ON (6)	Invalid; will cause MTA configuration alarm
7	Contactor Failure Action	OFF	All units should be off
		ON	Used when Shunt Trip is available in the unit
8	Not Used	—	—

**Table 5 — Compressor Protection Module Inputs and Outputs\***

DESCRIPTION	INPUT/OUTPUT	I/O TYPE	DISPLAY MODULE POINT NAME	CONNECTION POINT	
				Pin	Notation
Power (24 vac supply)	—	—	—	CPM-X-J1	
				11	24 vac
				12	Ground
Local Equipment Network	—	—	—	CPM-X-JP12	
				1	RS485 Port (D+)
				2	RS485 Port (Gnd)
				3	RS485 Port (D-)
				CPM-X-J12	
				1	RS485 Port (D+)
				2	RS485 Port (Gnd)
3	RS485 Port (D-)				
Circuit X High Pressure Switch	HPS-X	Switch	Not available	CPM-X-J7-CH05	
				1	
Oil Level Switch	Oil LS X	Switch	Circuit X Oil Solenoid, <i>OLS.X</i>	CPM-X-J6-CH06	
				1	
Must Trip Amp†	MTA (S2)	8-Pin DIP Switch	Must Trip Amps, <i>MTA.X</i>		
				2	
Configuration Switch†	S1	8-Pin DIP Switch	S1 Config Switch, <i>C.SW.X</i>		
				2	
Compressor X Motor Temperature	MTR-X	NTC Thermistor	Motor Temperature, <i>CTP.X</i>	CPM-X-J9-CH01	
				1	
Compressor X Discharge Gas Temperature	DGT X	NTC Thermistor	Discharge Gas Temp, <i>DGT.X</i>	CPM-X-J9-CH02	
				1	
Oil Pressure Transducer	OPT X	Pressure Transducer	Oil Pressure, <i>OP.X</i>	CPM-X-J10B-CH04	
				5V	+ 5 vdc ref
				S	Signal
				R	Return
Economizer Pressure Transducer	EPT X	Pressure Transducer	Economizer Pressure, <i>ECP.X</i>	CPM-X-J10A	
				5V	+ 5 vdc ref
				S	Signal
				R	Return
Compressor Current X Phase A		Current Sensor	<i>CUR.A</i>	CPM-X-J8-CH01	
				1	
Compressor Current X Phase B		Current Sensor	<i>CUR.B</i>	CPM-X-J8-CH02	
				1	
Compressor Current X Phase C		Current Sensor	<i>CUR.C</i>	CPM-X-J8-CH3	
				1	
Compressor X 1M Contactor	C X 1M	Contactor	Compressor Output, <i>CP.X</i>	CPM-X-J1-CH07	
				1	
Compressor X 2M Contactor	C X 2M	Contactor	Not available	CPM-X-J2-CH8	
				1	
Compressor X S Contactor	C X S	Contactor	Not available	CPM-X-J2-CH9	
				1	
Oil Heater Relay X (090-500 Only)	Oil HTR X	Contactor	Oil Heater Output, <i>HT.X</i>	CPM-X-J2-CH10	
				1	
Oil Solenoid X	Oil solenoid-X	Solenoid	Oil Solenoid Output, <i>OLS.X</i>	CPM-X-J2-CH12	
				1	
Load Solenoid X	Loading Solenoid-X	Solenoid	Slide Valve 1 Output, <i>SL1.X</i>	CPM-X-J2-CH13	
				1	
Unload Solenoid X	Unloading Solenoid-X	Solenoid	Slide Valve 2 Output, <i>SL2.X</i>	CPM-X-J2-CH14	
				1	
Gas Cooling Solenoid X (080,082 Only)	Gas Cooling Solenoid-X	Solenoid	DGT Cooling Solenoid, <i>DGT.X</i>	CPM-X-J2-CH10	
				1	
				2	

\*\*X" denotes the circuit, A, B or C.  
 †See Appendix D for MTA settings.



**Fig. 10 — EXV Board**



**Table 6 — EXVA Board Inputs and Outputs (30XA080,082)**

DESCRIPTION	INPUT/OUTPUT	I/O TYPE	DISPLAY MODULE POINT NAME	CONNECTION POINT	
				Pin	Notation
Power (24 vac supply)	—	—	—	EXVA-J1	
				11	24 vac
				12	Ground
Local Equipment Network	—	—	—	EXVA-J4	
				1	RS485 Port (D+)
				2	RS485 Port (Gnd)
				3	RS485 Port (D-)
Circuit A Suction Gas Thermistor	SGTA	5k Thermistor	Compressor Suction Temp, <i>SGT.A</i>	EXVA-J3	
				TH	
Circuit B Suction Gas Thermistor	SGTB	5k Thermistor	Compressor Suction Temp, <i>SGT.B</i>	EXVA-J3	
				TH	
Circuit A EXV	EXV-A	Stepper Motor	EXV Position, <i>EXV.A</i>	EXVA-J2A	
				1	
				2	
				3	
				4	
Circuit B EXV	EXV-B	Stepper Motor	EXV Position, <i>EXV.B</i>	EXVA-J2B	
				1	
				2	
				3	
				4	

**Table 7 — EXV A,B,C Board Inputs and Outputs\* (30XA090-500)**

DESCRIPTION	INPUT/OUTPUT	I/O TYPE	DISPLAY MODULE POINT NAME	CONNECTION POINT	
				Pin	Notation
Power (24 vac supply)	—	—	—	EXVX-J1	
				11	24 vac
				12	Ground
Local Equipment Network	—	—	—	EXVX-J4	
				1	RS485 Port (D+)
				2	RS485 Port (Gnd)
				3	RS485 Port (D-)
Circuit X Suction Gas Thermistor	SGT X	5k Thermistor	Compressor Suction Temp, <i>SGT.X</i>	EXVX-J3	
				TH	
Circuit X Economizer Gas Thermistor	ECT X	5k Thermistor	Economizer Gas Temp, <i>ECT.X</i>	EXVX-J3	
				TH	
Circuit X EXV	EXV-X	Stepper Motor	EXV Position, <i>EXV.X</i>	EXVX-J2A	
				1	
				2	
				3	
				4	
Circuit X Economizer EXV	ECEXV-X	Stepper Motor	Cir X Economizer EXV Pos, <i>ECO.X</i>	EXVX-J2A	
				1	
				2	
				3	
				4	

\*"X" denotes the circuit, A, B or C.

**Fan Boards** — At least one fan board is installed in each unit. See Fig. 11 and 12. There are two types of fan boards. One with and one without an analog output signal for the low ambient temperature head pressure control fan speed controllers. If a unit does not have low ambient temperature head pressure control installed, it will not have the analog connection terminals. The fan board responds to commands from the MBB and sends the MBB the results of the channels it monitors via the Local Equipment Network (LEN). See below for fan board A, B and C DIP switch addresses. See Tables 8-10 for inputs and outputs.

FAN BOARD (080,082) DIP SWITCH	1	2	3	4	5	6	7	8
Address:	OFF	ON	OFF	OFF	ON	OFF	ON	OFF

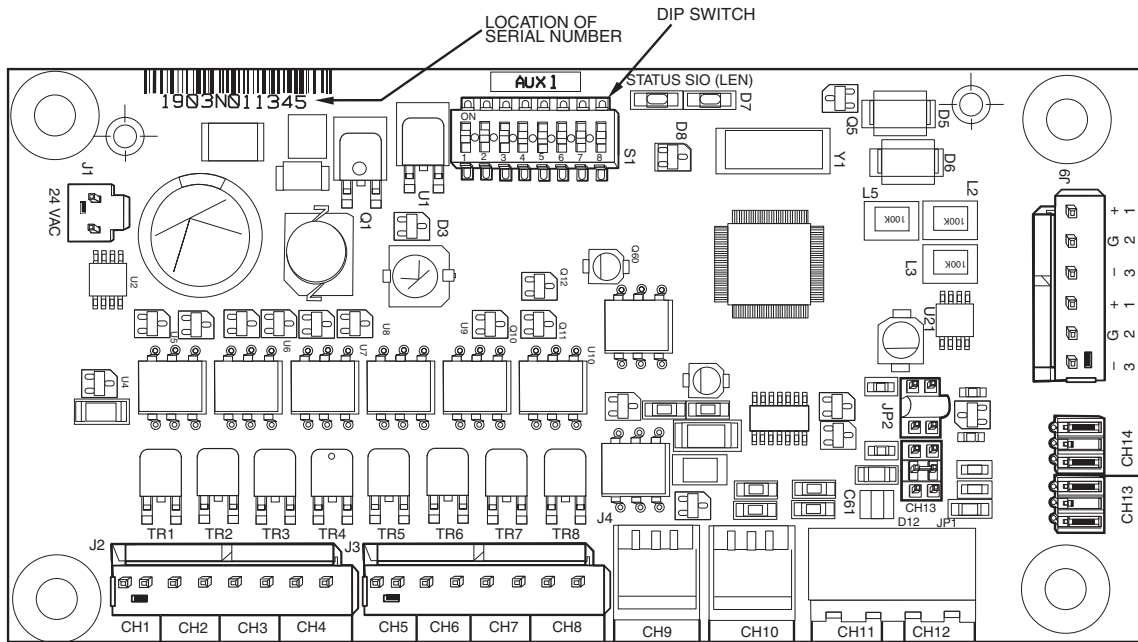
FAN BOARD A (090-500) DIP SWITCH	1	2	3	4	5	6	7	8
Address:	OFF	ON	OFF	OFF	ON	OFF	ON	OFF

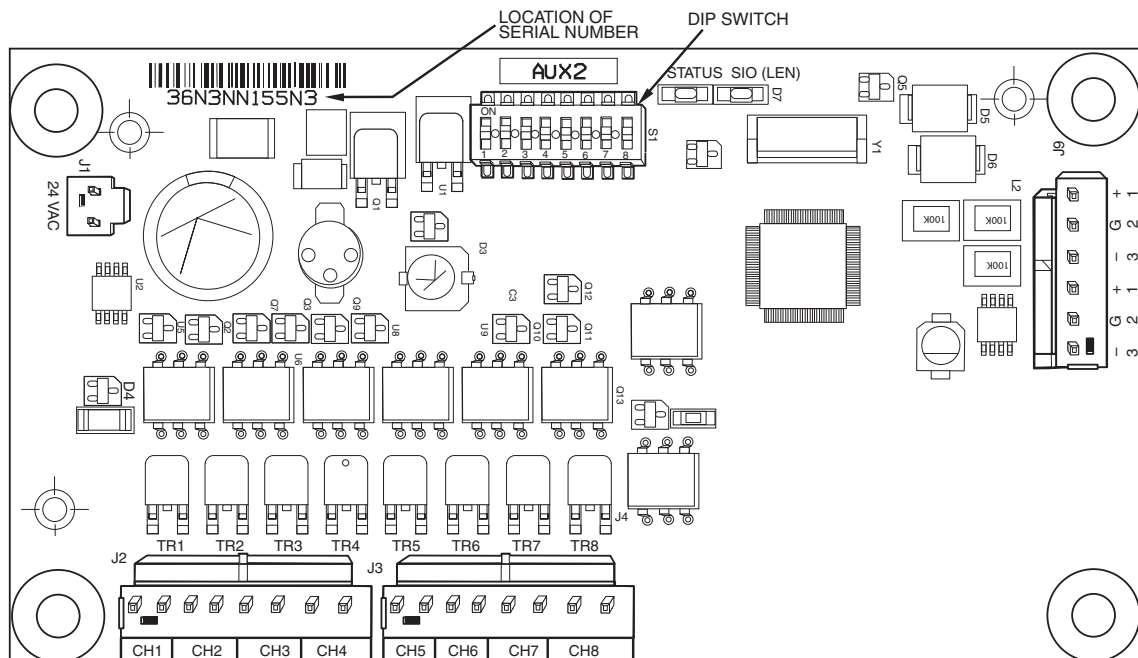
FAN BOARD B (140-500) DIP SWITCH	1	2	3	4	5	6	7	8
Address:	ON	ON	OFF	OFF	ON	OFF	ON	OFF

FAN BOARD C (400-500) DIP SWITCH	1	2	3	4	5	6	7	8
Address:	OFF	OFF	ON	OFF	ON	OFF	ON	OFF



**Fig. 11 — Fan Board (AUX 1) with Low Ambient Temperature Head Pressure Control**



**Fig. 12 — Fan Board (AUX 2) without Low Ambient Temperature Head Pressure Control**

**Table 8 — Fan Board A Outputs (30XA080-122)**

DESCRIPTION	INPUT/OUTPUT	I/O TYPE	DISPLAY MODULE POINT NAME	CONNECTION POINT	
				Pin	Notation
Power (24 vac supply)	—	—	—	FBA-J1	
				11	24 vac
				12	Ground
Local Equipment Network	—	—	—	FBA-J9	
				+	RS485 Port (D+)
				G	RS485 Port (Gnd)
				-	RS485 Port (D-)
				+	RS485 Port (D+)
				G	RS485 Port (Gnd)
Circuit A Low Ambient Temperature Head Pressure Control Speed Signal	MM-A*	0-10 VDC	Head Press Actuator Pos, <i>SPD.A</i>	FBA-CH9	
				+	Signal
				-	Ground
Circuit B Low Ambient Temperature Head Pressure Control Speed Signal	MM-B*	0-10 VDC	Head Press Actuator Pos, <i>SPD.B</i>	FBA-CH10	
				+	Signal
				-	Ground
Fan Contactor A1	FCA1	Contactora		FBA-J2-CH1	
Fan Contactor A2	FCA2	Contactora		FBA-J2-CH2	
Fan Contactor A3	FCA3	Contactora		FBA-J2-CH3	
Fan Contactor A4	FCA4	Contactora		FBA-J2-CH4 (090-122)	
Fan Contactor B1	FCB1	Contactora		FBA-J3-CH5	
Fan Contactor B2	FCB2	Contactora		FBA-J3-CH6	
Fan Contactor B3	FCB3	Contactora		FBA-J3-CH7	
Fan Contactor B4	FCB4	Contactora		FBA-J3-CH8 (090-122)	

\*Output only on low ambient temperature head pressure control (AUX1).

**Table 9 — Fan Board X Outputs (30XA140-352)**

DESCRIPTION	INPUT/OUTPUT	I/O TYPE	DISPLAY MODULE POINT NAME	CONNECTION POINT	
				Pin	Notation
Power (24 vac supply)	—	—	—	FBX-J1	
				11	24 vac
				12	Ground
Local Equipment Network	—	—	—	FBX-J9	
				+	RS485 Port (D+)
				G	RS485 Port (Gnd)
				-	RS485 Port (D-)
				+	RS485 Port (D+)
				G	RS485 Port (Gnd)
Circuit X Low Ambient Temperature Head Pressure Control Speed Signal	MM-n*	0-10 VDC	Head Press Actuator Pos, <i>SPD.X</i>	FBX-CH9	
				+	Signal
				-	Ground
Fan Contactor X1	FCX1	Contactora		FBX-J2-CH01	
Fan Contactor X2	FCX2	Contactora		FBX-J2-CH02	
Fan Contactor X3	FCX3	Contactora		FBX-J2-CH03	
Fan Contactor X4	FCX4	Contactora		FBX-J2-CH04	
Fan Contactor X5	FCX5	Contactora		FBX-J3-CH05	
Fan Contactor X6	FCX6	Contactora		FBX-J3-CH06	
Fan Contactor X7	FCX7	Contactora		FBX-J3-CH07	
Fan Contactor X8	FCX8	Contactora		FBX-J3-CH08	

\*Output only on units with low ambient temperature head pressure control installed (AUX1).

NOTES:

1. Fan Board B used on 30XA140-350.
2. "X" indicates circuit A or circuit B.
3. See page 109, Fig. 65 for which contactor is used with circuit A or B.

**Table 10 — Fan Board C Inputs and Outputs (30XA400-500)**

DESCRIPTION	INPUT/OUTPUT	I/O TYPE	DISPLAY MODULE POINT NAME	CONNECTION POINT (Unit Size)	
				Pin	Notation
Power (24 vac supply)	—	—	—	FBC-J1	
				11	24 vac
				12	Ground
Local Equipment Network	—	—	—	FBC-J9	
				+	RS485 Port (D+)
				G	RS485 Port (Gnd)
				-	RS485 Port (D-)
				+	RS485 Port (D+)
				G	RS485 Port (Gnd)
Circuit C Discharge Pressure Transducer	DPTC	Pressure Transducer	<i>Discharge Pressure, DP.C</i>	FBC-J7-CH13	
Circuit C Suction Pressure Transducer	SPTC	Pressure Transducer	<i>Suction Pressure, SP.C</i>	FBC-J8-CH14	
Circuit C Low Ambient Temperature Head Pressure Control Speed Signal	MM-C	0-10 VDC	<i>Head Press Actuator Pos, SPD.C</i>	FBC-CH9	
				+	Signal
				-	Ground
Fan Contactor C1	FCC1	Contact		FBC-J2-CH1	
Fan Contactor C2	FCC2	Contact		FBC-J2-CH2	
Fan Contactor C3	FCC3	Contact		FBC-J2-CH3	
Fan Contactor C4	FCC4	Contact		FBC-J2-CH4	
Fan Contactor C5	FCC5	Contact		FBC-J3-CH5	
Fan Contactor C6	FCC6	Contact		FBC-J3-CH6	
Fan Contactor C7	FCC7	Contact		FBC-J3-CH7	
Fan Contactor C8	FCC8	Contact		FBC-J3-CH8	

**Enable-Off-Remote Contact Switch (SW1) —**

This switch is installed in all units and provides the owner and service person with a local means of enabling or disabling the machine. It is a 3-position switch and it is used to control the chiller. When switched to the Enable position, the chiller will be under its own control. When switched to the Off position, the chiller will shut down. When switched to the Remote Contact position, a field-installed dry contact can be used to start the chiller. The contacts must be capable of handling a 24-vac, 50-mA load. In the Enable and Remote Contact (dry contacts closed) positions, the chiller is allowed to operate and respond to the scheduling configuration, CCN configuration, and set point data.

For units with a Touch Pilot™ display, the position of the Enable/Off/Remote contact switch is ignored except when the “remote mode” control type is selected. Refer to the Machine Control Methods section on page 22 for more details.

**Emergency On/Off Switch (SW2) —** This switch is installed in all units. The Emergency On/Off switch should only be used when it is required to shut the chiller off immediately. Power to all modules is interrupted when this switch is off and all outputs from these modules will be turned off.

**Energy Management Module (EMM) —** The EMM is available as a factory-installed option or as a field-installed accessory. See Fig. 13. The EMM receives 4 to 20 mA inputs for the temperature reset, cooling set point and demand limit functions. The EMM also receives the switch inputs for the field-installed second stage 2-step demand limit and ice done functions. The EMM communicates the status of all inputs with the MBB, and the MBB adjusts the control point, capacity

limit, and other functions according to the inputs received. See Table 11.

<b>⚠ CAUTION</b>
Care should be taken when interfacing with other manufacturer’s control systems due to possible power supply differences, full wave bridge versus half wave rectification, which could lead to equipment damage. The two different power supplies cannot be mixed. <i>ComfortLink™</i> controls use half wave rectification. A signal isolation device should be utilized if incorporating a full wave bridge rectifier signal generating device is used.

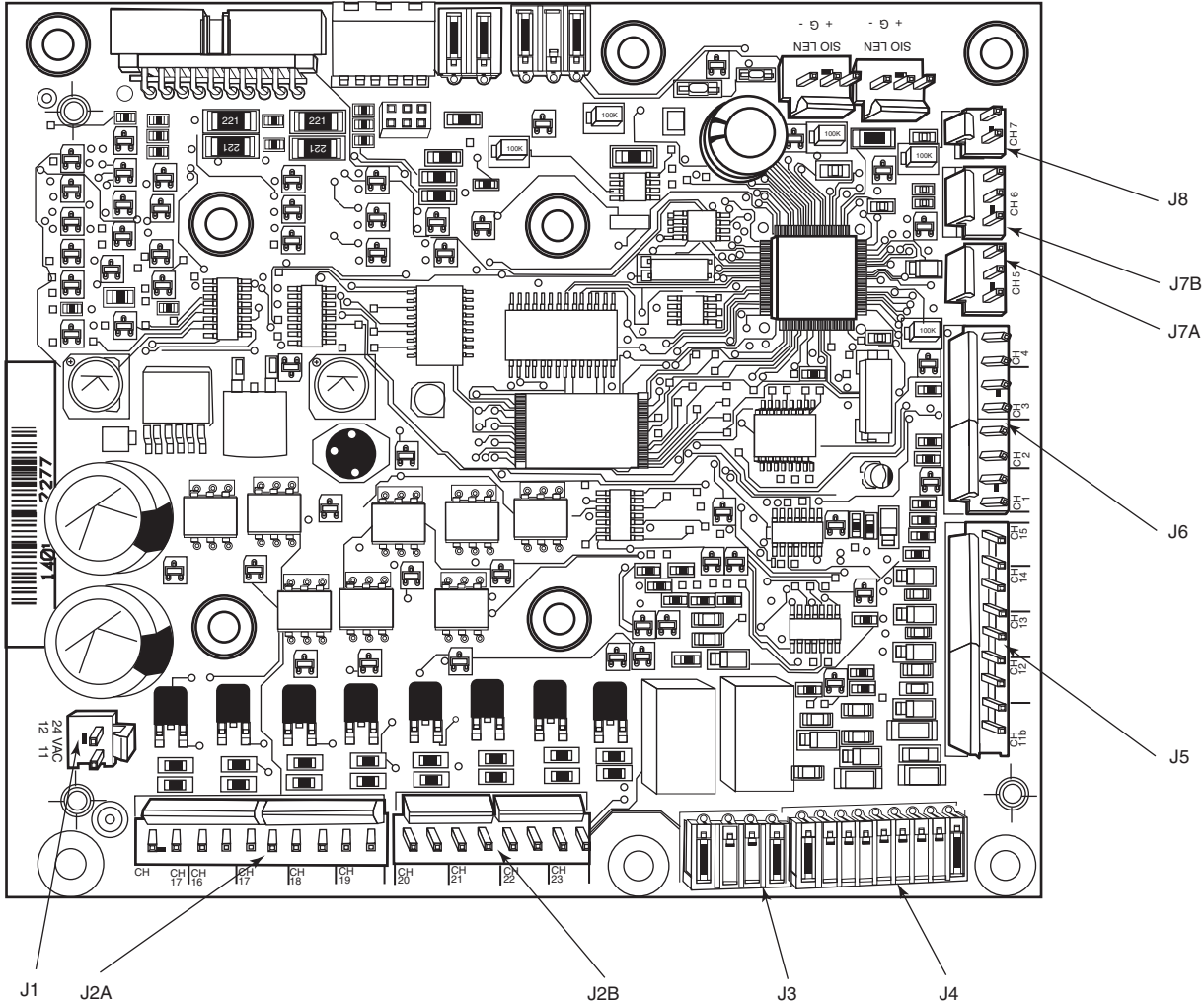
**Hot Gas Bypass/Pump Board —** The hot gas bypass (HGBP) and pump board controls the ON/OFF of the HGBP solenoids and pump contactors, and responds to MBB commands via the LEN connection. Hot gas bypass is available as a factory-installed option or as a field-installed accessory for 30XA080-500, and the pump package is available as factory-installed option for sizes 30XA090-162. See Fig. 14. The board is not required for single pump operation. See below for DIP switch information. See Table 12 for HGBP/Pump board inputs and outputs.

HGBP/Pump BOARD DIP SWITCH	1	2	3	4	5	6	7	8
Address:	ON	ON	ON	OFF	ON	OFF	ON	OFF

**Table 11 — Energy Management Module (EMM) Inputs and Outputs**

INPUT/OUTPUT	DESCRIPTION	I/O TYPE	DISPLAY MODULE POINT NAME	CONNECTION POINT
4-20 mA Demand Limit	4-20 mA Demand Limit	4-20 mA*	Limit 4-20 mA Signal, <i>DMD</i>	EMM-J7B-CH6
4-20 mA Temperature Reset/Cooling Setpoint	4-20 mA Temperature Reset/ Cooling Set point	4-20 mA*	Reset/Setpnt 4-20 mA Signal, <i>RSET</i>	EMM-J7A-CH5
Demand Limit SW2	Demand Limit Step 2	Switch Input	Switch Limit Setpoint 2, <i>DLS2</i>	EMM-J4-CH9
Ice Done	Ice Done Switch	Switch Input	Ice Done Storage Switch, <i>ICE.D</i>	EMM-J4-CH11A
Occupancy Override	Occupied Schedule Override	Switch Input	Occupied Override Switch, <i>OCCS</i>	EMM-J4-CH8
Remote Lockout Switch	Chiller Lockout	Switch Input	Remote Interlock Switch, <i>RLOC</i>	EMM-J4-CH10
SPT	Space Temperature Thermistor	10k Thermistor	Optional Space Temp, <i>SPT</i>	EMM-J6-CH2
% Total Capacity	Percent Total Capacity Output	0-10 vdc	Chiller Capacity Signal, <i>CATO</i>	EMM-J8-CH7
RUN R	Run Relay	Relay	Running Status, <i>RUN</i>	EMM-J3-CH25
SHD R	Shutdown Relay	Relay	Shutdown Indicator State, <i>SHUT</i>	EMM-J3-CH24

\* A field-supplied 1/2 watt 250 ohm resistor is required across terminals TB6-1,2 (CH6) and/or TB6-3, 4 (CH5).



**Fig. 13 — Energy Management Module**





**Table 13 — Touch Pilot™ Display Port Connections**

CONNECTOR	PIN	FUNCTION
J1 (Power)	1	24VAC +
	2	24VAC -
	3	Earth Ground
J2 (COM1)	1	RS485 Port (D+)
	2	RS485 Port (GND)
	3	RS485 Port (D-)
J3 (RJ11)	1	24VAC (+)
	2	RS485 Port (D+)
	3	RS485 Port (GND)
	4	Unused (no connect)
	5	RS485 Port (D-)
	6	24VAC(-)

**Carrier Comfort Network® (CCN) Interface —**

All 30XA units can be connected to the CCN, if desired. The communication bus wiring is a shielded, 3-conductor cable with drain wire and is field supplied and installed. The system elements are connected to the communication bus in a daisy chain arrangement. The positive pin of each system element communication connector must be wired to the positive pins of the system elements on either side of it. The negative and signal ground pins of each system element must also be wired in the same manner. Wiring connections for CCN should be made at TB3. Consult the CCN Contractor's Manual for further information. See Fig. 16.

NOTE: Conductors and drain wire must be 20 AWG (American Wire Gage) minimum stranded, tinned copper. Individual conductors must be insulated with PVC, PVC/nylon, vinyl, Teflon, or polyethylene. An aluminum/polyester 100% foil shield and an outer jacket of PVC, PVC/nylon, chrome vinyl, or Teflon with a minimum operating temperature range of -20 C to 60 C is required. See Table 14 for recommended wire manufacturers and part numbers.

**Table 14 — CCN Communication Bus Wiring**

MANUFACTURER	PART NUMBER	
	Regular Wiring	Plenum Wiring
Alpha	1895	—
American	A21451	A48301
Belden	8205	884421
Columbia	D6451	—
Manhattan	M13402	M64430
Quabik	6130	—

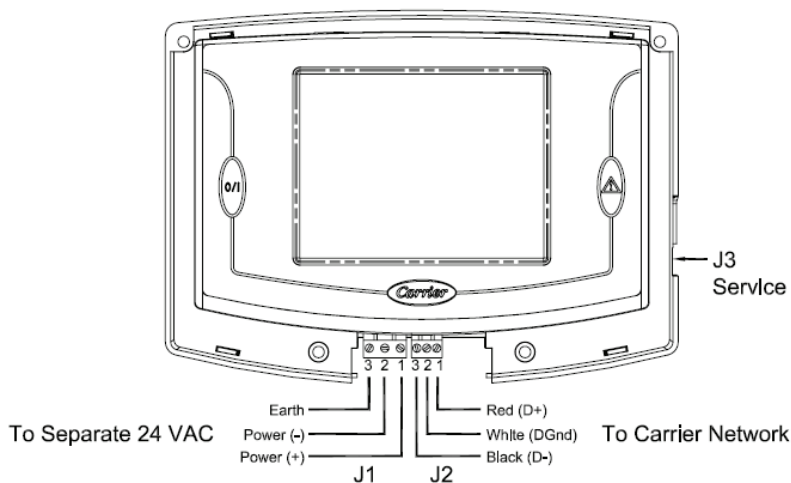
It is important when connecting to a CCN communication bus that a color-coding scheme be used for the entire network to simplify the installation. It is recommended that red be used for the signal positive, black for the signal negative, and white for the signal ground. Use a similar scheme for cables containing different colored wires.

At each system element, the shields of its communication bus cables must be tied together. If the communication bus is entirely within one building, the resulting continuous shield must be connected to a ground at one point only. If the communication bus cable exits from one building and enters another, the shields must be connected to grounds at the lightning suppressor in each building where the cable enters or exits the building (one point per building only). To connect the unit to the network:

1. Turn off power to the control box.
2. Cut the CCN wire and strip the ends of the red (+), white (ground), and black (-) conductors. (Substitute appropriate colors for different colored cables.)
3. Connect the red wire to (+) terminal on TB3 of the plug, the white wire to COM terminal, and the black wire to the (-) terminal.
4. The RJ14 CCN connector on TB3 can also be used, but is only intended for temporary connection (for example, a laptop computer running Service Tool).

**IMPORTANT:** A shorted CCN bus cable will prevent some routines from running and may prevent the unit from starting. If abnormal conditions occur, disconnect the CCN bus. If conditions return to normal, check the CCN connector and cable. Run new cable if necessary. A short in one section of the bus can cause problems with all system elements on the bus.

**Remote Alarm and Alert Relays —** The 30XA chiller can be equipped with a remote alert and remote alarm annunciator contacts. Both relays connected to these contacts must be rated for a maximum power draw of 10 va sealed, 25 va inrush at 24 volts. The alarm relay, indicating that the complete unit has been shut down, can be connected to TB5-12 and TB5-13. Refer to unit wiring diagrams. For an alert relay, indicating that at least 1 circuit is off due to the alert, a field-supplied and installed relay must be connected between MBB-J3-CH25-3 and TB5-13. The action of the alarm and alert relays can be reversed from normally open to normally closed by using the Reverse Alarms Relay configuration (**Reverse Alarms Relay, *RV.AL***).



**Fig. 15 — Touch Pilot™ Display Wiring**

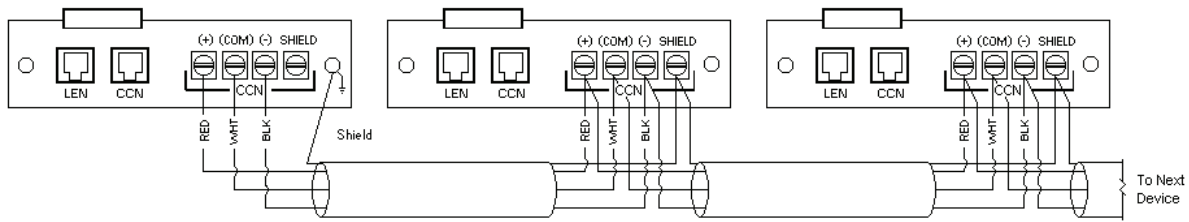


Fig. 16 — ComfortLink™ CCN Communication Wiring

## CONFIGURATION

### Touch Pilot™ Operation Configuration Tables

The Touch Pilot display operation is controlled by configuration information entered in the following configuration tables. These tables are accessible by using Network

Service Tool or ComfortVIEW™ software. The tables are the CtrlID (Controller Identification) configuration table and the USERCONF (User Configuration) table. See Tables 15 and 16.

NOTE: Always perform an Upload to obtain the latest configuration before making configuration table changes.

Table 15 — Touch Pilot Controller Identification Configuration Table

CONTROLLER ID DATA	BLOCK NO.	VALUE AND RANGE	QUALIFIERS
Device Name	1	CHILLDSP 8 character Name field	Default Optional
Local address	2	115	Default
Bus number	2	0	Default
Device (driver) type	2	0 = Non-bridge 3 = Broadcast Acknowledger	Default Optional
Primary baud rate	3	38400	Default
Secondary baud rate	3	38400	Fixed
Device description	4	Global Chiller Display 24 character text field	Default Optional
Device location	4	(Blank) 24 character text field	Default Optional
Software part number	4	CESR-131363-01	Fixed
Model number	4	(Blank)	Fixed
Serial number	4	(Blank)	Fixed
Reference number	4	Version 1.0	Fixed
Broadcast address processing list (primary)	5	241-251, 254, 255 enabled 241-255 enabled/disabled	Defaults Optional
Broadcast address processing list (secondary)	5	none	Not applicable

Table 16 — Touch Pilot™ User Configuration (USERCONF) Table

DESCRIPTION	LIMITS	UNITS	NAME	DEFAULT
Backlight always on?	No - Yes		BACKLITE	No
Full access password	0 - 9999		PSWDFULL	3333
Limited access password	0 - 9999		PSWDLMTD	2222
Active language	0 - 1		ACTLANG	0
Time format	0 - 1		TIMEFMT	0
Date format	0 - 2		DATEFMT	0
Units base	US - Metric		UNITBASE	US
Contrast control	Manual - Auto		CONTRAST	Auto
Network mode	0 - 1		NETWORK	0
Network settings				
Alarm acknowledger	No - Yes		ALARMACK	No
Broadcast acknowledger	No - Yes		BROADACK	No
Equipment CCN address				
Bus number	0 - 239		EQUIPBUS	0
Element number	1 - 239		EQUIPELE	1
Control variables				
Equipment status (Not Used)	Name char 8		EQSTATUS	NOT USED
Equipment start/stop (Not Used)	Name char 8		STARSTOP	NOT USED
Alarm status (Not Used)	Name char 8		ALSTATUS	NOT USED
Alarm reset (Not Used)	Name char 8		ALRESET	NOT USED

**BACKLIGHT ALWAYS ON?** — This configuration is used to keep the backlight on continuously or to turn it off after 60 seconds with no activity.

Allowable Entries: No/Yes (No=0 or Yes=1)

Default Value: No

**FULL ACCESS PASSWORD** — This configuration is used to specify the full access password. Refer to Table 1, Setup Menu, for additional information on passwords.

Allowable Entries: 0 through 9999

Default Value: 3333

**LIMITED ACCESS PANEL** — This configuration is used to specify the limited access password.

Allowable Entries: 0 through 9999

Default Value: 2222

**ACTIVE LANGUAGE** — This configuration is used to specify the display's active language. All translatable text will be displayed in this language.

Allowable Entries: 0, 1

Default Value: 0

**TIME FORMAT** — This configuration is used to specify the format for display of time.

Allowable Entries: 0 = H:MM AM/PM without leading zero  
1 = HH:MM with leading zero when necessary

Default Value: 0

**DATE FORMAT** — This configuration is used to specify the format for display of date.

Allowable Entries: 0 = MM-DD-YYYY with leading zero when necessary  
1 = DD-MM-YYYY with leading zero when necessary  
2 = YYYY-MM-DD

Default Value: 0

**UNITS BASE** — This configuration is used to specify the format of the units of measure.

Allowable Entries: U.S.  
Metric

Default Value: U.S.

**CONTRAST CONTROL** — This configuration is used to enable or disable the display's auto contrast adjustment feature. When enabled, the display's contrast will be automatically adjusted as required, based on temperature.

Allowable Entries: Manual  
(Auto Contrast Adjustment Disabled)  
Auto  
(Auto Contrast Adjustment Enabled)

Default Value: Auto

**NETWORK MODE** — This configuration is used to set the display's operating mode. For additional information on operating mode, refer to *Display* in the Table Setup Menu. This decision will be ignored and the mode will default to Equipment when the display is connected to a device (the LEN Bus).

NOTE: A power cycle is required for this decision to take effect.

Allowable Entries: 0 (Disable) = Equipment Mode  
1 (Enable) = Network Mode

Default Value: 0 (Disable)

**ALARM ACKNOWLEDGER** — This configuration is used to specify whether the Touch Pilot™ display will act as the alarm acknower for the CCN. There can be only one alarm acknower per CCN. Therefore, if another CCN device

such as ComfortVIEW™ software, the Autodial Gateway or TeLINK is already set as the alarm acknower for the CCN network then this decision should be set to *No*.

NOTE: The display must be in Network mode and connected to the primary CCN bus and this decision set to *Yes* for alarm acknowerment to be enabled.

Allowable Entries: No

Yes

Default Value: No

**BROADCAST ACKNOWLEDGER** — This configuration is used to indicate whether the Touch Pilot display will act as the broadcast acknower for its CCN bus. There can be only one broadcast acknower per CCN bus.

NOTE: The display must be in Network mode and this decision set to *Yes* for broadcast acknowerment to be enabled.

Allowable Entries: No

Yes

Default Value: No

**EQUIPMENT CCN ADDRESS** — When in equipment mode (USERCONF Table's Network Mode decision is set to *Disable*), the Bus Number and Element Number decisions are used to specify the CCN address of the piece of equipment to communicate with. An Attach or power cycle must be performed for changes to take effect. These decisions will be ignored when the display is connected to the LEN bus or in Network mode. In Network mode, specify the bus and element number the equipment communicates with using the display's Attach function.

NOTE: In Network mode, these configurations will be overwritten with the default device address if it is changed through the Attach process.

**BUS NUMBER** — This configuration is used to specify the Equipment Controller bus number.

Allowable Entries: 0 through 239

Default Value: 0

**ELEMENT NUMBER** — This configuration is used to specify the Equipment Controller element number.

Allowable Entries: 1 through 239

Default Value: 1

**Machine Control Methods** — Three variables control how the machine operates. These variables control the On-Off function, set point operation, and Heat-Cool operation.

**Machine On/Off Control** — Machine On/Off control depends on which interface display is used. The control is different for Touch Pilot™ or Navigator™ displays. Select the correct configuration procedure below based on which interface is being used.

**TOUCH PILOT MACHINE CONTROL** — Machine On/Off control is determined locally by pushing the Start/Stop button on the Touch Pilot display. Pressing this button will cause the Equipment Start screen to be displayed. See Fig. 17.

Table 17 summarizes the unit control type and stop or go status with regard to the following parameters:

- Operating type: this is selected by using the start/stop button on the front of the user interface.
- Remote start/stop contacts: these contacts are used when the unit is in remote operating type (Remote mode).
- CHIL\_S\_S: this network command variable relates to the chiller start/stop when the unit is in CCN control (CCN mode). When this variable forced to Disable, then the unit is stopped. When this variable is forced to Enable, then the unit runs in accordance with schedule 1.

- Start/Stop schedule: occupied or unoccupied status of the unit as determined by the chiller start/stop program (Schedule 1).
- Master control type: This parameter is used when the unit is the master unit in a two chiller lead/lag arrangement. The master control type determines whether the unit is to be controlled locally, remotely or through CCN (this parameter is a Service configuration).
- CCN emergency shutdown: if this CCN command is activated, it shuts the unit down whatever the active operating type.
- General alarm: the unit is totally stopped due to failure.

**Local Mode** — To start the machine in local mode, press the Start/Stop button on the Touch Pilot display. The Equipment Start screen will be displayed. Select Local On. The control will ignore the position of Enable/Off/Remote Contact switch and all CCN network force commands, except an Emergency Stop Command. The **Run Status** variable, indicating the current status of the machine, will change to RUNNING, DELAY or READY. The **Chiller Occupied?** variable will change to YES. The **Control Type** variable indicates the type of control. For this configuration, **Control Type** will be Local. The **Operating Type** variable will change to L-On (Local On).

**Local Schedule** — To start the machine with a local schedule, press the Start/Stop button on the Touch Pilot display. The Equipment Start screen will be displayed. Select Local Schedule. The unit will start and stop according to the schedule defined in the Time Schedule menu. Two Internal Time Schedules are available and must be field programmed. Time Schedule 1 is used for single set point On-Off control. Time Schedule 2 is used for Dual Set Point/Occupied-Unoccupied set point control. The control will ignore the position of Enable/Off/Remote Contact switch and all CCN network force commands, except the Emergency Stop Command.

The **Run Status** variable will indicate the current status of the machine — OFF, RUNNING, DELAY, or READY. The **Chiller Occupied?** variable will indicate the occupied state of the machine according to Time Schedule 1 and will be either YES (occupied) or NO (unoccupied). The **Control Type** variable will indicate the type of control. For this configuration,

**Control Type** will be Local. The **Operating Type** variable will change to L-Sched (Local Schedule).

The schedules consist of 8 user-configurable occupied time periods. The control supports time schedules for local control, remote control, and ice building. These time periods can be flagged to be in effect or not in effect on each day of the week. The day begins at 00.00 and ends at 24.00. The machine will be in unoccupied mode unless a scheduled time period is in effect. If an occupied period extends past midnight, the occupied period will automatically end at 24:00 hours (midnight) and the new occupied period must be programmed to begin at 00:00 hours.

In the following example, the occupied period starts at 6:00 AM, Monday through Friday and 10:00 AM on Saturday and Sunday. The occupied time ends at 6:30 PM on Monday through Friday and 2:00 PM on Saturday and Sunday. See Fig. 18.



Fig. 17 — Equipment Start Screen

Table 17 — Touch Pilot™ Start/Stop Control

ACTIVE OPERATING TYPE							PARAMETER STATUS					CONTROL TYPE	UNIT STATUS
Local On	Local On	Local Schedule	Remote Mode	CCN Mode	Master Mode	CHIL_S_S Variable	Remote Start/Stop Contact	Master Unit Control Type	Start/Stop Schedule Mode	CCN Emergency Shutdown	General Alarm		
-	-	-	-	-	-	-	-	-	-	Active	-	-	Off
-	-	-	-	-	-	-	-	-	-	-	Yes	-	Off
Active	-	-	-	-	-	-	-	-	-	-	-	Local	Off
-	-	Active	-	-	-	-	-	-	Unoccupied	-	-	Local	Off
-	-	-	Active	-	-	-	Off	-	-	-	-	Remote	Off
-	-	-	Active	-	-	-	-	-	Unoccupied	-	-	Remote	Off
-	-	-	-	Active	-	Off	-	-	-	-	-	CCN	Off
-	-	-	-	Active	-	-	-	-	-	-	-	CCN	Off
-	-	-	-	-	Active	-	-	Local	Unoccupied	-	-	Local	Off
-	-	-	-	-	Active	-	Off	Remote	-	-	-	Remote	Off
-	-	-	-	-	Active	-	-	Remote	Unoccupied	-	-	Remote	Off
-	-	-	-	-	Active	Off	-	CCN	-	-	-	CCN	Off
-	-	-	-	-	Active	-	-	CCN	Unoccupied	-	-	CCN	Off
-	Active	-	-	-	-	-	-	-	-	Disabled	No	Local	On
-	-	Active	-	-	-	-	-	-	Occupied	Disabled	No	Local	On
-	-	-	Active	-	-	-	On Cool	-	Occupied	Disabled	No	Remote	On
-	-	-	-	Active	-	On	-	-	Occupied	Disabled	No	CCN	On
-	-	-	-	-	Active	-	-	Local	Occupied	Disabled	No	Local	On
-	-	-	-	-	Active	-	On Cool	Remote	Occupied	Disabled	No	Remote	On
-	-	-	-	-	Active	On	-	CCN	Occupied	Disabled	No	CCN	On



OCC1P01S		1-5/8	
1.	M T W T F S S H	From	To
	X X X X X	06:00	18:30
2.	M T W T F S S H	From	To
	X X	10:00	14:00
3.	M T W T F S S H	From	To
	X	12:00	14:00
4.	M T W T F S S H	From	To
		00:00	24:00
5.	M T W T F S S H	From	To
		00:00	24:00

Fig. 18 — Chiller Schedule Screen

NOTE: This schedule was designed to illustrate the programming of the schedule function and is not intended as a recommended schedule for chiller operation.

If the chiller is to be controlled to a single set point, use Schedule 1 (OCCPC01S). This will start and stop the machine. During the unoccupied times, the chiller will be off. If the chiller is to be controlled to 2 set points, occupied and unoccupied, use Schedule 2 (OCCPC02S). This will cause the chiller to control to an occupied set point and an unoccupied set point. The machine will be able to provide cooling at any time.

To configure this option on the Touch Pilot™ display see Table 18.

Table 18 — Configuring the Schedule with Touch Pilot Display

DISPLAY NAME	PATH	LINE NO.	VALUE
Period 1 DOW (MTWTFSSH)	Config\ OCCDEFCS\ OCC1P01S or OCC1P02S	2	10000000
Occupied from		3	00:00
Occupied to		4	03:00
Period 2 DOW (MTWTFSSH)		5	11000000
Occupied from		6	07:00
Occupied to		7	18:00
Period 3 DOW (MTWTFSSH)		8	00100000
Occupied from		9	07:00
Occupied to		10	21:30
Period 4 DOW (MTWTFSSH)		11	00011000
Occupied from		12	07:00
Occupied to		13	17:00
Period 5 DOW (MTWTFSSH)		14	00000100
Occupied from		15	07:00
Occupied to		16	12:00

**Holiday Schedule** — For the Touch Pilot display, the control allows up to 16 holiday periods. All holidays are entered with numerical values. To configure, first change the month (**Holiday Start Month**), then the day (**Holiday Start Day**), then the duration (**Holiday Duration**) of the holiday period in days. If a holiday is included in one of the Occupied Time Periods of the schedule, the machine will follow that operating condition for the holiday. In the following examples, the holidays July 4 and December 25-26 are programmed for Holiday 1 and Holiday 2, respectively. To configure these holidays with the Touch Pilot display, see Table 19. To configure Holidays with the Navigator display, check the H (holiday) schedule on the Schedule screen and program in the desired occupied times. See Fig. 18.

Table 19 — Programming Holiday Schedules with Touch Pilot Display

DISPLAY NAME	PATH	LINE NO.	VALUE
Holiday Start Month	Config\HOLIDAY\HOLDY_01	1	7
Start Day		2	4
Duration (days)		3	1
Holiday Start Month	Config\HOLIDAY\HOLDY_02	1	12
Start Day		2	25
Duration (days)		3	2

**Timed Override** — With the Touch Pilot display only, each time schedule can be overridden to keep the chiller in an Occupied mode (Timed Override Hours) for 1, 2, 3 or 4 hours on a one-time basis. To configure this option for the Touch Pilot display, see Table 20.

Table 20 — Configuring Timed Override

DISPLAY NAME	PATH	LINE NO.	VALUE
Timed Override Hours	Config\OCCDEFCS\ OCC1P01S or OCC1P02S	1	Range: 0 to 4 Default: 0

If configured for a timed override, the override can be cancelled by changing the Timed Override Hours to 0.

**CCN Global Time Schedule** — A CCN Global Schedule can be utilized with the chiller controls. The schedule number can be set anywhere from 65 to 99 to configure operation under a CCN global schedule. The 30XA chillers can be configured to follow a CCN Global Time Schedule broadcast by another system element. ComfortVIEW™ Network Manager's Configure and Modify commands or the Service Tool's Modify/Names function must be used to change the number of the Occupancy Equipment Part Table Name (OCC1P01E) to the Global Schedule Number. The Schedule Number can be set from 65 to 99 (OCC1P65E to OCC1P99E).

The Occupancy Supervisory Part table name (OCC1P01S) number must be changed to configure the unit to broadcast a Global Time Schedule. The Schedule Number can be set from 65 to 99 (OCC1P65S to OCC1P99S). When OCC1PxxS is set to a value greater than 64, an occupancy flag is broadcast over the CCN every time it transitions from occupied to unoccupied or vice-versa. By configuring their appropriate Time Schedule decisions to the same number, other devices on the network can follow this same schedule.

**CCN Mode** — To allow machine control by CCN commands, press the Start/Stop button on the Touch Pilot™ display. The Equipment Start screen will be displayed. Select CCN Mode. The unit will be controlled by a CCN command to the **CCN Chiller Start/Stop** variable. An external CCN device, such as Chillervisor, controls the On/Off state of the machine. When controlled by a Chillervisor, it is recommended that the **Auto Start When SM Lost** configuration be set to Yes. In the event of a loss of communication with the network, the machine will start and be controlled locally.

Careful evaluation of chilled water plant control should be reviewed. In the event local control is established, be sure that all pumps, valves, and other devices are capable of operating properly. The control will ignore the position of Enable/Off/Remote Contact switch. The **Run Status** variable will indicate the current status of the machine — OFF, RUNNING, DELAY, or READY. The **Control Type** variable will change to CCN. The **Operating Type** variable will change to CCN.

For dual chiller control applications, the slave chiller must be enabled using the CCN Mode button.

**Remote Mode** — To allow machine to start and stop via a remote contact closure, press the Start/Stop button on the Touch Pilot display. The Equipment Start screen will be

displayed. Select Remote Mode. The unit will be controlled by the Enable/Off/Remote Contact switch. Switching the Enable/Off/Remote Contact switch to the Enable or Remote Contact position (external contacts closed) will force the unit into an occupied state. In this mode, all CCN network force commands, except the Emergency Stop Command will be ignored. The **Run Status** variable will indicate the current status of the machine (OFF, RUNNING, DELAY, or READY), depending on the position of the Remote/Off/Enable Switch closure. The **Chiller Occupied?** variable will change to YES. The **Control Type** variable will change to Remote. The **Operating Type** variable will change to Remote.

**Master Mode** — To activate Dual Chiller Control, each machine must be individually configured for Dual Chiller Control. To operate the machines in Dual Chiller Mode, one machine must be designated as the master unit and one machine as the slave unit. On the master unit, press the Start/Stop button on the Touch Pilot display. The Equipment Start screen will be displayed. Select Master Mode. Failure to start the Master unit in this manner will cause both machines to operate in local mode.

The Master Unit Control can be done locally, remotely or through CCN commands per the master/slave configuration (**Master Control Type**). The control will ignore the position of Enable/Off/Remote Contact switch if the **Master Control Type** is configured for Local Control or CCN Control. The **Run Status** variable, **Chiller Occupied?** variable, and **Control Type** variable will change based on the **Master Control Type** configured above and the Machine On/Off Control defined above. The **Operating Type** variable will change to Master.

**To Turn Machine Off** — To turn the machine off, press the Start/Stop button on the Touch Pilot display. See Fig. 19. The machine will shut down. While the unit is in Local Off, it will remain shut down and ignore all CCN commands as well as the position of Enable/Off/Remote Contact switch. The **Run Status** variable, indicating the current status of the machine, will change to OFF. The **Chiller Occupied?** variable will change to NO. The **Control Type** variable will indicate Local. The **Operating Type** variable will change to L-OFF (Local Off).

**NAVIGATOR™ DISPLAY MACHINE CONTROL** — Machine On/Off control with the Navigator display is determined by the configuration of the Operating Type Control (**OPER**). Options to control the machine locally via a switch, from a local Time Schedule, or via a Carrier Comfort Network® command are offered. See Table 21.

**Switch Control** — In the Switch Control operating type, the Enable/Off/Remote Contact switch controls the machine locally. All models are factory configured with Operating Type Control (**OPER**) set to **SWITCH CTRL** (Switch Control). With **SWITCH CTRL**, switching the Enable/Off/Remote Contact switch to the Enable or Remote Contact position (external contacts closed) will put the chiller in an occupied state. The Unit Run Status (**STAT**) will indicate the current status of the machine and will change from OFF to RUNNING or DELAY. The unit Occupied Status (**OCC**) will change from NO to YES. The Status Unit Control Type (**CTRL**) will change from LOCAL OFF when the switch is Off to LOCAL ON when in the Enable position or in the Remote Contact position with external contacts closed.

ITEM	ITEM EXPANSION	PATH	VALUE
<b>OPER</b>	Operating Control Type	Operating Modes→SLCT→OPER	SWITCH CTRL

**Time Schedule** — With Time Schedule Operating Type control, the machine operates under a local schedule programmed by the user as long as the Enable/Off/Remote Contact switch is in the Enable or Remote Contact position (external contacts closed). To operate under this Operating Type Control (**OPER**) must be set to **TIME SCHED** (Time Schedule).



Fig. 19 — Equipment Stop Screen

Table 21 — Navigator Start/Stop Control

CONTROL METHOD (OPER)	ACTIVE OPERATING TYPE	REMOTE/OFF/ENABLE SWITCH	REMOTE ON/OFF SWITCH	TIME SCHEDULE 1	CCN CHILLER START/STOP (CHIL_S_S)	EMERGENCY STOP (EMSTOP)	ALARM	REMOTE LOCKOUT SWITCH	UNIT STATUS
All	Local Off	Off	—	—	—	—	—	—	Off
		Remote	Open	—	—	—	—	—	Off
		—	—	—	—	—	Enable	—	Off
		—	—	—	—	—	—	Yes	Off
		—	—	—	—	—	—	Closed	Off
Switch Control	Local On	Enable	—	—	—	Disable	—	—	On
		Remote	Closed	—	—	Disable	—	—	On
Time Schedule	Local Schedule	Enable	—	Occupied	—	Disable	—	—	On
		Remote	Closed	Occupied	—	Disable	—	—	On
		—	—	Unoccupied	—	Disable	—	—	Off
CCN Control	CCN	Remote	Closed	—	Enable	Disable	—	—	On
		Remote	Closed	—	Disable	Disable	—	—	Off
		Enable	—	—	Enable	Disable	—	—	On
		Enable	—	—	Disable	Disable	—	—	Off

Two Internal Time Schedules are available and must be field programmed. Time Schedule 1 (*SCH1*) is used for single set point On-Off control. Time Schedule 2 (*SCH2*) is used for dual set point On-Off and Occupied-Unoccupied set point control. The control will use the operating schedules as defined under the Time Clock mode in the Navigator display module.

ITEM	ITEM EXPANSION	PATH	VALUE
OPER	Operating Control Type	Operating Modes→SLCT→OPER	TIME SCHED

The schedules consist of 8 user-configurable occupied time periods. The control supports time schedules for local control, remote control, and ice building. These time periods can be flagged to be in effect or not in effect on each day of the week. The day begins at 00.00 and ends at 24.00. The machine is in unoccupied mode unless a scheduled time period is in effect. If an occupied period is to extend past midnight, the occupied period must end at 24:00 hours (midnight) and a new occupied period must be programmed to begin at 00:00 hours.

In the following example, a early morning pulldown time period is scheduled for Monday morning from 12:00 AM to 3:00 AM. The occupied period starts at 7:00 AM, Monday through Saturday. The occupied time ends at 6:00 PM on Monday and Tuesday, 9:30 PM on Wednesday, 5:00 PM on Thursday and Friday, and 12:00 PM on Saturday.

NOTE: This schedule was designed to illustrate the programming of the schedule function and is not intended as a recommended schedule for chiller operation.

If the chiller is to be controlled to a single set point, use Schedule 1 (*SCH1*). This type of schedule will start and stop the machine only. During the unoccupied times, the chiller will be off. If the chiller is to be controlled to 2 set points, occupied and unoccupied, use Schedule 2 (*SCH2*). This will cause the chiller to control to an occupied set point and an unoccupied set point. The machine will be able to provide cooling at any time.

To configure this option while using the Navigator™ display, see Table 22.

**Holiday Schedule** — The unit control allows up to 16 holiday periods. All holidays are entered with numerical values. First enter the month (*MON.x*), then the day (*DAY.x*), then the duration (*DUR.x*) of the holiday period in days. If a holiday is included in one of the Occupied Time Periods of the schedule, the machine will follow that operating condition for the holiday. In the following examples, the holidays July 4 and December 25-26 are programmed for Holiday 1 and Holiday 2 respectively.

To configure this option for the Navigator display, see Table 23.

**CCN Global Time Schedule** — A CCN global schedule can be used if desired. The schedule number can be set anywhere from 65 to 99 for operation under a CCN global schedule. The 30XA chillers can be configured to follow a CCN Global Time Schedule broadcast by another system element. The ComfortVIEW™ Network Manager's Configure and Modify commands or the Service Tool's Modify/Names function must be used to change the number of the Occupancy Equipment Part Table Name (OCC1P01E) to the Global Schedule Number. The Schedule Number can be set from 65 to 99 (OCC1P65E to OCC1P99E).

**Table 22 — Configuring Schedules with Navigator™ Display**

ITEM	ITEM EXPANSION	PATH	VALUE
OCC.1	Occupied Time	Time Clock→SCH1→PER.1 or Time Clock→SCH2→PER.1	00:00
UNO.1	Unoccupied Time		03:00
MON.1	Monday Select		Yes
TUE.1	Tuesday Select		No
WED.1	Wednesday Select		No
THU.1	Thursday Select		No
FRI.1	Friday Select		No
SAT.1	Saturday Select		No
SUN.1	Sunday Select		No
HOL.1	Holiday Select		No
OCC.2	Occupied Time	Time Clock→SCH1→PER.2 or Time Clock→SCH2→PER.2	07:00
UNO.2	Unoccupied Time		18:00
MON.2	Monday Select		Yes
TUE.2	Tuesday Select		Yes
WED.2	Wednesday Select		No
THU.2	Thursday Select		No
FRI.2	Friday Select		No
SAT.2	Saturday Select		No
SUN.2	Sunday Select		No
HOL.2	Holiday Select		No
OCC.3	Occupied Time	Time Clock→SCH1→PER.3 or Time Clock→SCH2→PER.3	07:00
UNO.3	Unoccupied Time		21:30
MON.3	Monday Select		No
TUE.3	Tuesday Select		No
WED.3	Wednesday Select		Yes
THU.3	Thursday Select		No
FRI.3	Friday Select		No
SAT.3	Saturday Select		No
SUN.3	Sunday Select		No
HOL.3	Holiday Select		No
OCC.4	Occupied Time	Time Clock→SCH1→PER.4 or Time Clock→SCH2→PER.4	07:00
UNO.4	Unoccupied Time		17:00
MON.4	Monday Select		No
TUE.4	Tuesday Select		No
WED.4	Wednesday Select		No
THU.4	Thursday Select		Yes
FRI.4	Friday Select		Yes
SAT.4	Saturday Select		No
SUN.4	Sunday Select		No
HOL.4	Holiday Select		No
OCC.5	Occupied Time	Time Clock→SCH1→PER.5 or Time Clock→SCH2→PER.5	07:00
UNO.5	Unoccupied Time		12:00
MON.5	Monday Select		No
TUE.5	Tuesday Select		No
WED.5	Wednesday Select		No
THU.5	Thursday Select		No
FRI.5	Friday Select		No
SAT.5	Saturday Select		Yes
SUN.5	Sunday Select		No
HOL.5	Holiday Select		No

**Table 23 — Configuring Holiday Schedules for Navigator Display**

ITEM	ITEM EXPANSION	PATH	VALUE
MON.1	Holiday Start Month	Time Clock→HOLI→HOL.1	7
DAY.1	Holiday Start Day		4
DUR.1	Holiday Duration in Day		1
MON.2	Holiday Start Month	Time Clock→HOLI→HOL.2	12
DAY.2	Holiday Start Day		25
DUR.2	Holiday Duration in Day		2

The Occupancy Supervisory Part table name (OCC1P01S) number must be changed to configure the unit to broadcast a Global Time Schedule. The Schedule Number can be set from 65 to 99 (OCC1P65S to OCC1P99S). When OCC1PxxS is set to a value greater than 64, an occupancy flag is broadcast over the CCN every time it transitions from occupied to unoccupied or vice-versa. By configuring their appropriate Time Schedule decisions to the same number, other devices on the network can follow this same schedule. The Enable/Off/Remote Contact must be in the Enable position or the Remote Contact position with the contacts closed for the unit to operate. The Unit Run Status (**STAT**) will indicate the current status of the machine (OFF, RUNNING, STOPPING or DELAY), depending on the schedule. The unit Occupied status (**OCC**) will indicate the current occupied schedule according to the schedule, either NO or YES. The Status Unit Control Type (**CTRL**) will be LOCAL OFF when the switch is Off. The Status Unit Control Type will be CCN when the Enable/Off/Remote Contact switch input is On.

**CCN Control** — With CCN Operating Type control, the machine operates under CCN control as long as the Enable/Off/Remote Contact Switch is in the Enable or Remote Contact position (external contacts closed.) To operate under this Operating Control, OPER must be set to CCN CONTROL. An external CCN device, such as Chillervisor, controls the On/Off state of the machine. When controlled by a Chillervisor, it is recommended that the Auto Start When SM Lost (**AU.SM**) be set to Yes.

Careful evaluation of Chilled Water Plant control should be reviewed. In the event Local Control is established, be sure that all pumps, valves, and other devices are capable of operating properly. In the event of a loss of communication with the network, the machine will start and be controlled locally. The CCN device forces the variable CHIL\_S\_S to control the chiller. The Unit Run Status (**STAT**) will indicate the current status of the machine (OFF, RUNNING, STOPPING or DELAY), depending on the CCN command. The unit Occupied status (**OCC**) will indicate the current occupied state according to the CCN command and will be displayed as either NO or YES. The Status Unit Control Type (**CTRL**) will be LOCAL OFF when the Enable/Off/Remote Contact switch is Off. The Status Unit Control Type will be CCN when the Enable/Off/Remote Contact switch input is Closed and the CHIL\_S\_S variable is Stop or Start.

For Dual Chiller Control applications, the Slave Chiller must be enabled using the CCN CONTROL option.

ITEM	ITEM EXPANSION	PATH	VALUE
OPER	Operating Control Type	Operating Modes→SLCT→OPER	CCN CONTROL
AU.SM	Auto Start when SM Lost	Configuration→SERV	YES

**Fluid Set Point Control Location** — The factory default for the chilled water fluid set point is controlling to the leaving water temperature. An option to configure the machine for entering water control is available. The control operation remains the same except the control point is focused on the entering water temperature, rather than the leaving water temperature when configured.

To configure this option for the Touch Pilot™ display:

DISPLAY NAME	PATH	LINE NO.	VALUE
Entering Fluid Control	Service\ SERVICE1	5	No = Leaving Water Control Yes = Entering Water Control

To configure this option for the Navigator™ display:

ITEM	ITEM EXPANSION	PATH	VALUE
EWTO	Entering Water Control	Configuration→SERV	No = Leaving Water Control Yes = Entering Water Control

**Cooling Set Point Selection** — Several options for controlling the Leaving Chilled Water Set Point are offered and are configured by the Cooling Set Point Select (**Setpoint Select, SP.SE**) variable. In addition to the Cooling Set Point Select, Ice Mode Enable discussed later in this book, and Heat Cool Select (**Heat/Cool Select, HC.SE**) variables also have a role in determining the set point of the machine. All units are shipped from the factory with the Heat Cool Select set to 0.

All default set points are based on Leaving Water Control (**Entering Fluid Control, EWTO**) set to No. Values must be confirmed for the individual set points. Limits for the set points are listed in the configurations noted below.

To configure these options for the Touch Pilot display, see Table 24A. To configure these options for the Navigator display, see Table 24B.

**Table 24A — Cooling Set Point Selection with Touch Pilot Display**

DISPLAY NAME	PATH	LINE NO.	VALUE
Cooling Setpoint 1	Setpoint	2	Range: 14 to 70 F (-10.0 to 21.1 C) Default: 44 F (6.6 C)
Cooling Setpoint 2	Setpoint	3	Range: 14 to 70 F (-10.0 to 21.1 C) Default: 44 F (6.6 C)
Cooling Ice Setpoint	Setpoint	4	Range: -20 to 32 F (-28.9 to 0 C) Default: 44 F (6.6 C)

**Table 24B — Cooling Set Point Selection with Navigator Display**

ITEM	ITEM EXPANSION	PATH	VALUE
CSP.1	Cooling Setpoint 1	Setpoints→COOL	Range: 14 to 70 F (-10.0 to 21.1 C) Default: 44 F (6.6 C)
CSP.2	Cooling Setpoint 2	Setpoints→COOL	Range: 14 to 70 F (-10.0 to 21.1 C) Default: 44 F (6.6 C)
CSP.3	Ice Setpoint	Setpoints→COOL	Range: -20 to 32 F (-28.9 to 0 C) Default: 44 F (6.6 C)

In all cases, there are limits on what values are allowed for each set point. These values depend on the Cooler Fluid Type and the Brine Freeze Set point, discussed later. See Table 25.

**Table 25 — Configuration Set Point Limits**

SET POINT LIMITS	COOLER FLUID TYPE (COOLER FLUID TYPE, FLUD)	
	1, Water	2, Brine
Minimum *	38 F (3.3 C)	14 F (-10.0 C)
Maximum	60 F (15.5 C)	

\*The minimum set point for Medium Temperature Brine applications is related to the Brine Freeze Point. The set point is limited to be no less than the Brine Freeze Point +5° F (2.8° C).

The Setpoint Select configuration can be set to five different control options: Set Point Occupancy, Set Point 1, Set Point 2, 4-20 mA Input, and Dual Switch.

**SET POINT OCCUPANCY** — Set Point Occupancy is the default configuration for the Setpoint Select variable. When Setpoint Select (**Setpoint Select, SP.SE**) is configured to 0 (Setpoint Occ), the unit's active set point is based on Cooling

Set Point 1 (**Cooling Setpoint 1, CSP1**) during the occupied period while operating under Time Schedule 1 (**SCH1**). If the Time Schedule 2 (**SCH2**) is in use, the unit's active set point is based on Cooling Set Point 1 (**Cooling Setpoint 1, CSP1**) during the occupied period and Cooling Set Point 2 (**Cooling Setpoint 2, CSP2**) during the unoccupied period. See Tables 26 and 27.

To configure this option while using a Touch Pilot display:

DISPLAY NAME	PATH	LINE NO.	VALUE
Setpoint select	Status→GENUNIT	25	0 (Setpoint Occupied)

To change this value, a Control Point Force must be applied. When configured correctly, Setpoint Control (**Setpoint Control, SP.SE**) will indicate Auto.

To configure this option while using a Navigator display:

ITEM	ITEM EXPANSION	PATH	VALUE
SP.SE	Setpoint Select	Operating Modes→SLCT	Setpoint Occ

**Set Point 1** — When Set Point Select (**Setpoint Select, SP.SE**) is configured to 1 (**Setpoint 1**), the unit's active set point is based on Cooling Set Point 1 (**Cooling Setpoint 1, CSP1**).

To configure this option with the Touch Pilot display:

DISPLAY NAME	PATH	LINE NO.	VALUE
Setpoint select	Status→GENUNIT	25	1 (Set Point 1)

To change this value, a Control Point Force must be applied. When configured correctly, **Setpoint Control** will indicate Setp 1.

To configure this option with the Navigator™ display:

ITEM	ITEM EXPANSION	PATH	VALUE
SP.SE	Setpoint Select	Operating Modes→SLCT	Setpoint 1

**Set Point 2** — When Set Point Select (**Setpoint Select, SP.SE**) is configured to 2 (**Setpoint 2**), the unit's active set point is based on Cooling Set Point 2 (**Cooling Setpoint 2, CSP2**).

To configure this option with the Touch Pilot™ display:

DISPLAY NAME	PATH	LINE NO.	VALUE
Setpoint select	Status→GENUNIT	25	2 (Set Point 2)

To change this value, a Control Point Force must be applied. When configured correctly, Setpoint Control (**Status→GENUNIT**) will indicate Setp 2.

To configure this option with the Navigator display:

ITEM	ITEM EXPANSION	PATH	VALUE
SP.SE	Setpoint Select	Operating Modes→SLCT	Setpoint 2

**4 to 20 mA Input** — When Set Point Select (**Setpoint Select, SP.SE**) is configured to 3 (4-20 mA Setp), the unit's active set point is based on an field supplied, external 4 to 20 mA signal input to the Energy Management Module (EMM). Care should be taken when interfacing with other manufacturer's control systems, due to power supply differences of full wave bridge versus half wave rectification. The two different power supplies cannot be mixed. *ComfortLink™* controls use half wave rectification. A signal isolation device should be utilized if a full wave bridge signal generating device is used.

The following equation is used to control the set point. See Fig. 20.

$$\text{Fahrenheit Set Point} = 10 + 70(\text{mA} - 4)/16 \text{ (deg F)}$$

$$\text{Celsius Set Point} = -12.2 + 38.9(\text{mA} - 4)/16 \text{ (deg C)}$$

To configure this option while using a Touch Pilot display:

DISPLAY NAME	PATH	LINE NO.	VALUE
Setpoint select	Status→GENUNIT	25	3 (4-20 mA Input)

To change this value, a Control Point Force must be applied. When configured correctly, **Setpoint Control** will indicate 4-20 mA.

To configure this option while using a Navigator display:

ITEM	ITEM EXPANSION	PATH	VALUE
SP.SE	Setpoint Select	Operating Modes→SLCT	4-20 mA Setp

**Dual Switch** — When Set Point Select (**Setpoint Select, SP.SE**) is configured to 4 (Dual Setp Sw), the unit's active set point is based on Cooling Set Point 1 (**Cooling Setpoint 1, CSP1**) when the Dual Set Point switch contact is open and Cooling Set Point 2 (**Cooling Setpoint 2, CSP2**) when it is closed.

To configure this option while using a Touch Pilot display:

DISPLAY NAME	PATH	LINE NO.	VALUE
Setpoint select	Status→GENUNIT	25	4 (Dual Setpoint Switch)

To change this value, a Control Point Force must be applied. When configured correctly, **Setpoint Control** will indicate Setp Sw.

To configure this option while using a Navigator display:

ITEM	ITEM EXPANSION	PATH	VALUE
SP.SE	Setpoint Select	Operating Modes→SLCT	Dual Setp Sw

**Chilled Water Fluid Type Selection** — The chilled water fluid must be configured. The fluid type must be configured to obtain the proper leaving water set point control range and freeze protection. The Cooler Fluid Type (**Cooler Fluid Type, FLUD**) can be set to water or brine.

**FRESH WATER** — Configure the unit for Cooler Fluid Type (**Cooler Fluid Type, FLUD**) to water for units without brine or glycol installed in the chilled water loop. The factory default fluid type is fresh water. Use this option for fresh water systems. This will allow for a water temperature set point of 38 to 60 F (3.3 to 15.5 C). With water as the selection, the Freeze Point is fixed at 34 F (1.1 C).

To configure this option with the Touch Pilot display:

DISPLAY NAME	PATH	LINE NO.	VALUE
Cooler Fluid Type	Main Menu→Service→SERVICE1	1	1 = Water

To configure this option with the Navigator display:

ITEM	ITEM EXPANSION	PATH	VALUE
FLUD	Cooler Fluid Type	Configuration→SERV	Water



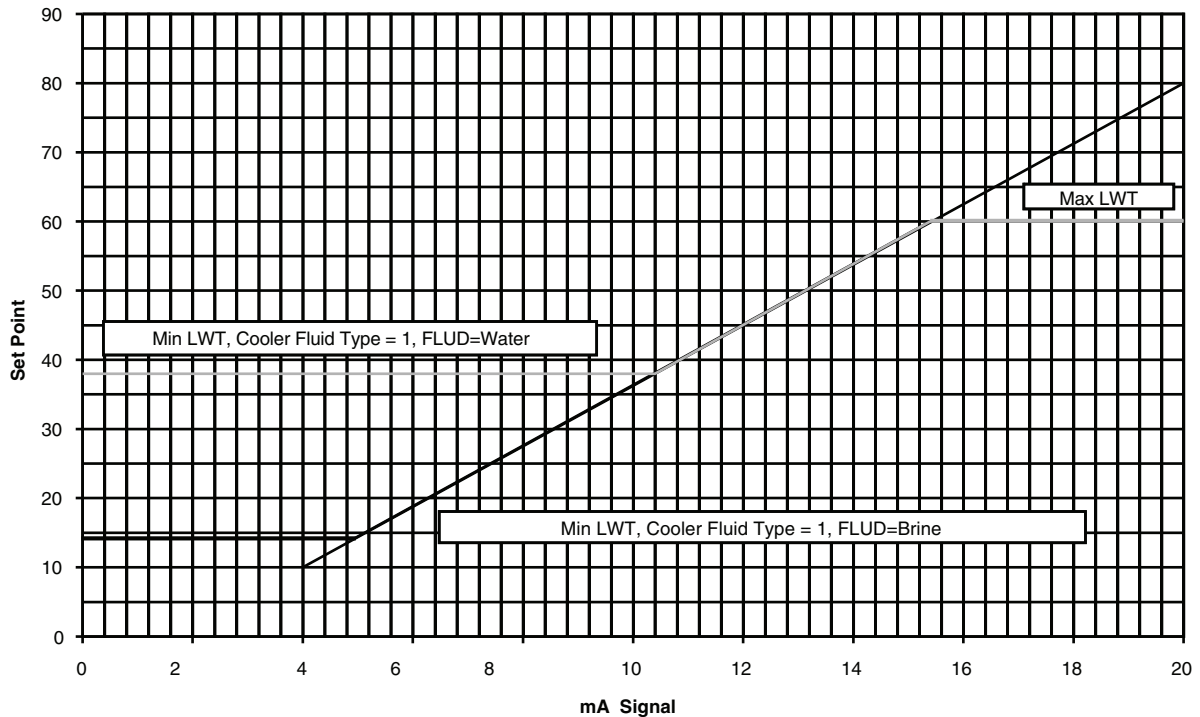


Fig. 20 — 4 to 20 mA Set Point Control

Table 26 — Cooling Set Point Selection Touch Pilot™ Parameters

SET POINT CONFIGURATION (Setpoint Select)	ICE MODE ENABLE (ice_cnfg)	DUAL SET POINT INPUT (SETP_SW)	ICE DONE INPUT (ICE_SW)	TIME SCHEDULE 2	ACTIVE SET POINT
0 (Auto)	NO	—	—	Occupied	Cooling Setpoint 1
		—	—	Unoccupied	Cooling Setpoint 2
	YES	—	Open	Unoccupied	Cooling Ice Setpoint
		—	Closed	Unoccupied	Cooling Setpoint 2
1 (Setp 1)	—	—	—	Occupied	Cooling Setpoint 1
2 (Setp 2)	—	—	—	—	Cooling Setpoint 2
3 (4-20 mA)	—	—	—	—	4 to 20 mA Input
4 (Setp Sw)	NO	Open	—	—	Cooling Setpoint 1
		Closed	—	—	Cooling Setpoint 2
	YES	Open	—	—	Cooling Setpoint 1
		Closed	Open	—	Cooling Ice Setpoint
		Closed	Closed	—	Cooling Setpoint 2

Table 27 — Cooling Set Point Selection Navigator™ Parameters

Control Method (OPER)	Heat/Cool Select (HC.SE)	PARAMETER STATUS					ACTIVE SET POINT
		Setpoint Select (SP.SE)	Ice Mode Enable (ICE.M)	Ice Done (ICE.D)	Dual Setpoint Switch (DUAL)	Setpoint Occupied (SP.OC)	
LOCAL	COOL	Setpoint Occ	—	—	—	Occupied	CSP.1
		Setpoint Occ	—	—	—	Unoccupied	CSP.2
		Setpoint Occ	Enable	Open	—	Unoccupied	CSP.3
		Setpoint 1	—	—	—	—	CSP.1
		Setpoint 2	—	—	—	—	CSP.2
		4-20mA Setp	—	—	—	—	4_20mA
		—	Enable	Open	Closed	—	CSP.3
		—	Enable	Closed	Closed	—	CSP.2
		—	—	—	Open	—	CSP.1
Dual Setp Sw	—	—	Closed	—	CSP.2		
CCN	COOL	—	—	—	—	Occupied	CSP.1
		—	—	—	—	Unoccupied	CSP.2

BRINE OR GLYCOL OPERATION — Configure the unit for Cooler Fluid Type (**Cooler Fluid Type, FLUD**) to brine or glycol chilled water loops. This option will allow for a set point temperature range of 14 to 60 F (-10.0 to 15.5 C). Before configuring this selection, confirm that a suitable anti-freeze has been added and is at a sufficient concentration to protect the loop. Additionally, the Brine Freeze Set Point (**Brine Freeze Setpoint, LOSP**) must be set for proper freeze protection operation. Set the Brine Freeze Set Point to the burst protection provided by the glycol concentration. This value will be Freeze Point for the fluid.

To configure this option with the Touch Pilot display:

DISPLAY NAME	PATH	LINE NO.	VALUE
Cooler Fluid Type	Main Menu →Service→SERVICE1	1	2 = Brine
Brine Freeze Setpoint	Main Menu →Service→SERVICE1	3	Dependent on fluid concentration

To configure this option with the Navigator display:

ITEM	ITEM EXPANSION	PATH	VALUE
FLUD	Cooler Fluid Type	Configuration→SERV	Brine
LOSP	Brine Freeze Setpoint	Configuration→SERV	Dependent on fluid concentration

**Cooler Pump Control** — It is required for flooded cooler units that cooler pump control be utilized on all chillers unless the chilled water pump runs continuously or the chilled water system contains a suitable antifreeze solution. The 30XA units can be configured for single external pump control as standard. Control of dual external pumps requires installation of the external pump control accessory package (Part No. 00EFN900003200A).

Cooler Pumps Sequence (**Cooler Pumps Sequence, PUMP**) is the variable that must be confirmed in the field. Proper configuration of the cooler pump control is required to provide reliable chiller operation. Pump control can be accomplished for both on-board and external pumps. For external pump control, control connections to the pump contactor and a feedback circuit from the contactor must be supplied. The Cooler Pumps Sequence configuration can be set to 5 different control settings: No Pump Control, Single Pump Control, Dual Pump Control, Pump 1 Manual, and Pump 2 Manual.

When the Cooler Pumps Sequence is configured, the cooler pump output will be energized when the chiller enters an “ON” mode. The cooler pump output is also energized when certain alarms are generated. The cooler pump output should be used as an override to the external pump control if cooler pump control is not utilized. The cooler pump output is energized if a P.01 Water Exchanger Freeze Protection alarm is generated, which provides additional freeze protection if the system is not protected with a suitable antifreeze solution.

A chilled water pump interlock contact PMP-I is connected across TB5 terminals 1-2, as an alternative to the standard jumper. This interlock is an optional field-installed device which would provide extra protection in the event of the flow switch failing closed. It may be used regardless of whether or not pump control is enabled. However, this interlock should NOT be confused with the pump contactor feedback auxiliary contacts which MUST be wired to MBB channel 18 at connector J5C if the pump control feature is enabled (with or without the optional on-board hydronic package).

NO PUMP CONTROL — The factory default setting for Cooler Pumps Sequence (**Cooler Pumps Sequence, PUMP**) is 0 (No Pump), for units without the factory-installed hydronic package.

When Cooler Pumps Sequence is set to 0 (No Pump), closure of both the chilled water flow switch (CWFS) and the chilled water pump interlock contact (connected across TB-5 terminals 1 and 2) are required for the unit to start mechanical cooling.

To configure this option with the Touch Pilot™ display:

DISPLAY NAME	PATH	LINE NO.	VALUE
Cooler Pumps Sequence	Main Menu→Config→USER	8	0 (No Pump Control)

To configure this option with the Navigator™ display:

ITEM	ITEM EXPANSION	PATH	VALUE
PUMP	Cooler Pumps Sequence	Configuration→OPTN	No Pump

SINGLE PUMP CONTROL — For units with the single pump hydronic package, the factory default setting for Cooler Pumps Sequence (**Cooler Pumps Sequence, PUMP**) is 1 (1 Pump Only). This control algorithm may be used to control an external pump, as long as the same controls are applied as noted below.

When the Cooler Pumps Sequence configuration is set to 1 Pump Only, closure of both the chilled water flow switch (CWFS) and the chilled water pump interlock contact (connected across TB-5 terminals 1 and 2) are required for the unit to start mechanical cooling. Additionally, the normally open auxiliary contacts for Pump 1 contactor must be connected to the violet and pink wires located in the harness from the MBB-J5C-CH18 connector. The wires in the harness are marked “PMP1-13” and “PMP1-14”. See the field wiring diagram in the 30XA Installation Instructions.

Three additional parameters are configurable for pump control with single pump control. Periodic pump start and check flow if pump is off parameters can customize the pump operation for the application. Another parameter, to stop the pump in standby mode is not supported.

The control system has the ability to periodically start the pumps to maintain the bearing lubrication and seal integrity. If Periodic Pump Start (**Pump Sticking Protection, PM.PS**) is set to YES and the unit is off at 2:00 PM, the pump will be started once each day for 2 seconds. The default for this option is NO.

Another configuration to check the status of the chilled water flow switch can be selected. When configured, if Flow Checked if Pump Off (**Flow Checked if C Pump Off, PLOC**) is set to YES, the control will monitor the chilled water flow switch status and will alarm if the pump is commanded off and the chilled water flow switch is closed. This can provide the user with information of a faulty cooler pump contactor or a failed chilled water flow switch. This parameter should be set to NO for series flow machines. The factory default for this item is YES.

To configure this option with the Touch Pilot display:

DISPLAY NAME	PATH	LINE NO.	VALUE
Cooler Pumps Sequence	Main Menu→Config→USER	8	1 (Single Pump Control)
Pump Sticking Protection	Main Menu→Config→USER	15	Default = No No = Disabled Yes = Enabled
Flow Checked if C Pump Off	Main Menu→Config→USER	17	Default = Yes No = Disabled Yes = Enabled

To configure this option with the Navigator display:

ITEM	ITEM EXPANSION	PATH	VALUE
<b>PUMP</b>	Cooler Pumps Sequence	Configuration→OPTN	1 Pump Only
<b>PM.PS</b>	Periodic Pump Start	Configuration→OPTN	Default = No No = Disabled Yes = Enabled
<b>P.LOC</b>	Flow Checked if Pmp Off	Configuration→OPTN	Default = Yes No = Disabled Yes = Enabled

**DUAL PUMP AND MANUAL CONTROL** — For units with the dual pump hydronic package, the factory default setting for Cooler Pumps Sequence (**Cooler Pumps Sequence, PUMP**) is 2 (2 Pumps Auto). This control algorithm may be used to control two external pumps, as long as the same controls are applied as noted below. For dual pump hydronic option units, three control options exist. The control will start the pumps and automatically alternate the operation of the pumps to even the wear of the pumps based on the hours configured under Pump Auto Rotation Delay (**Pump Auto Rotation Delay, ROT.P**). If the difference between the operating hours of the 2 pumps exceeds the Pump Auto Rotation Delay the lead pump will change. If a flow failure is detected, the other pump will attempt to start.

Two manual control options also exist. When the Cooler Pumps Sequence (**Cooler Pumps Sequence, PUMP**) is set to 3 (PMP 1 Manual), Cooler Pump 1 will always operate. When the Cooler Pumps Sequence (**Cooler Pumps Sequence, PUMP**) is set to 4 (PMP 2 Manual), Cooler Pump 2 will always operate.

If the Cooler Pumps Sequence configuration is set to 2 (2 Pumps Auto), 3 (PMP 1 Manual), or 4 (PMP 2 Manual), closure of both the chilled water flow switch (CWFS) and the chilled water pump interlock contact (connected across TB-5 terminals 1 and 2) are required for the unit to start mechanical cooling. Additionally, the normally open auxiliary contacts for Pump 1 and Pump 2 contactors (wired in parallel) must be connected to the violet and pink wires located in the harness from the MBB-J5C-CH18 connector. The wires in the harness are marked “PMP1-13” and “PMP1-14”. See the field wiring diagram in the 30XA Installation Instructions.

Three additional parameters are configurable for pump control with single pump control. The Periodic Pump Start (**Pump Sticking Protection, PM.PS**) and Flow Checked if Pump Off (**Flow Checked if C Pump Off, P.LOC**) parameters can customize the pump operation for the application. Another parameter, that is used to stop the pump in standby mode, is not supported.

The control system has the ability to periodically start the pumps to maintain the bearing lubrication and seal integrity. If Periodic Pump Start (**Pump Sticking Protection, PM.PS**) is set to YES and if the unit is off at 2:00 PM, a pump will be started once each day for 2 seconds. If the unit has 2 pumps, Pump 1 will be started on even days (such as day 2, 4, or 6 of the month); Pump 2 will be started on odd days (such as day 1, 3 or 5 of the month). The default for this option is NO.

A configuration to check the status of the chilled water flow switch can be selected. When Flow Checked if Pump Off (**Flow Checked if C Pump Off, P.LOC**) is configured to YES, the control will monitor the chilled water flow switch status and will alarm if the pump is commanded off and the chilled water flow switch is closed. This can provide the user with information of a faulty cooler pump contactor or a failed chilled water flow switch. This parameter should be set to NO for series flow machines. The factory default for this item is YES.

To configure these options with the Touch Pilot™ display:

DISPLAY NAME	PATH	LINE NO.	VALUE
<b>Cooler Pumps Sequence</b>	Main Menu →Config→USER	8	2 (2 Pumps Automatic) 3 (Pump 1 Manual) 4 (Pump 2 Manual)
<b>Pump Auto Rotation Delay</b>	Main Menu →Config→USER	14	Default = 48 hours
<b>Pump Sticking Protection</b>	Main Menu →Config→USER	15	Default = No No = Disabled Yes = Enabled
<b>Flow Checked if C Pump Off</b>	Main Menu →Config→USER	17	Default = Yes No = Disabled Yes = Enabled

To configure these options with the Navigator™ display:

ITEM	ITEM EXPANSION	PATH	VALUE
<b>PUMP</b>	Cooler Pumps Sequence	Configuration→OPTN	2 Pumps Auto PMP1 Manual PMP2 Manual
<b>ROT.P</b>	Pump Rotation Delay	Configuration→OPTN	Default = 48 hours
<b>PM.PS</b>	Periodic Pump Start	Configuration→OPTN	Default = No No = Disabled Yes = Enabled
<b>P.LOC</b>	Flow Checked if Pmp Off	Configuration→OPTN	Default = Yes No = Disabled Yes = Enabled

**Machine Start Delay** — An option to delay the start of the machine is also available. This parameter is useful in keeping multiple machines from starting at the same time in case of a power failure. The parameter has a factory default of 1 minute. This parameter also has a role in the timing for a chilled water flow switch alarm.

To configure this option with the Touch Pilot display:

DISPLAY NAME	PATH	LINE NO.	VALUE
<b>Unit Off to On Delay</b>	Main Menu →Config→USER	6	Default = 1 Minute

To configure this option with the Navigator display:

ITEM	ITEM EXPANSION	PATH	VALUE
<b>DELY</b>	Minutes Off Time	Configuration→OPTN	Default = 1 Minute

### Circuit/Compressor Staging and Loading —

The AquaForce® 30XA chillers employ one compressor per circuit. As a result, circuit and compressor staging are the same. The control has several control option parameters to load the compressors. The circuit/compressor start can be configured as well as the loading of each circuit/compressor.

**CIRCUIT/COMPRESSOR STAGING** — The control can be configured to decide which circuit/compressor starts first, by configuring Lead/Lag Circuit Select (**Staged Loading Sequence, LLCS**). Four options for this variable are allowed: Automatic Lead-Lag, Circuit A Leads, Circuit B Leads, or Circuit C Leads (30XA400-500 only). The factory default is Automatic Lead-Lag.

The automatic lead-lag function determines which circuit/compressor starts. When enabled, the control will determine which circuit/compressor starts to even the wear of the compressor. The compressor wear factor (combination of starts and run hours) is used to determine which compressor starts.

$$\text{Compressor Wear Factor} = (\text{Compressor Starts}) + 0.1 (\text{Compressor Run Hours})$$

The circuit/compressor with the lowest compressor wear factor is the circuit that starts first.

If starting a particular circuit/compressor first is desired, that can also be configured with the same variable.

To configure this option with the Touch Pilot display:

DISPLAY NAME	PATH	LINE NO.	VALUE
<b>Circuit Loading Sequence</b>	Main Menu →Config→USER	1	0 (Automatic Lead-lag) 1 (Circuit A Leads) 2 (Circuit B Leads) 3 (Circuit C Leads) Default = 0 (Automatic Lead-lag)

To configure this option with the Navigator display:

ITEM	ITEM EXPANSION	PATH	VALUE
<b>LLCS</b>	Lead/Lag Circuit Select	Configuration →OPTN	Range: Automatic, Cir A Leads, Cir B Leads, Cir C Leads Default – Automatic

**CIRCUIT/COMPRESSOR LOADING** — The control can be configured to stage the circuit/compressors. The Loading Sequence Select (**Circuit Loading Sequence, LOAD**) setting determines how the control will perform loading. The configuration can be set to Equal or Staged.

**Equal Loading** — With Equal loading, the circuit which starts first will maintain the minimum stage of capacity with the slide valve fully unloaded. When additional capacity is required, the next circuit with the lowest compressor wear factor is started with its slide valve at minimum position. As additional capacity is required, the slide valve for a circuit will be adjusted in approximately 5% increments to match capacity requirements. The control will alternate between circuits to maintain the same percentage of capacity on each circuit. See Fig. 21.

**Staged Loading** — If staged loading is selected, the circuit which starts first will gradually load its slide valve to match capacity requirements until the circuit is fully loaded. Once the circuit is fully loaded and additional capacity is required, the control will start an additional circuit fully unloaded. The control will gradually unload the circuit which was fully loaded to match capacity requirements. See Fig. 21.

To configure this option with the Touch Pilot™ display:

DISPLAY NAME	PATH	LINE NO.	VALUE
<b>Staged Loading Sequence</b>	Main Menu→Config→USER	4	Default = No No (Equal) Yes (Staged)

To configure this option with the Navigator™ display:

ITEM	ITEM EXPANSION	PATH	VALUE
<b>LOAD</b>	Loading Sequence Select	Configuration→OPTN	Default = Equal Equal Staged

**Minimum Load Control** — Minimum Load Control can be a factory-installed option or a field-installed accessory. If installed, and its operation is desired, the Minimum Load Control must be enabled. Once enabled, the valve will be operational only during the first stage of cooling.

To configure this option with the Touch Pilot display:

DISPLAY NAME	PATH	LINE NO.	VALUE
<b>Hot Gas Bypass Select</b>	Main Menu→Service →FACTORY	14	Default = No No (No Minimum Load Control) Yes (Minimum Load Control Installed)

To configure this option with the Navigator display:

ITEM	ITEM EXPANSION	PATH	VALUE
<b>HGBP</b>	Hot Gas Bypass Select	Configuration→UNIT	No = No Minimum Load Control Yes = Minimum Load Control Installed

**Dual Chiller Control** — The dual chiller routine is available for the control of two units installed in series or parallel supplying chilled fluid on a common loop. One chiller must be configured as the master chiller, the other as the slave chiller. An additional leaving fluid temperature thermistor (Dual Chiller LWT) must be installed in the common chilled water piping as described in the Installation Instructions for both the master and slave chillers. See the Field Wiring section in the 30XA Installation Instructions for Dual Chiller LWT sensor control wiring.

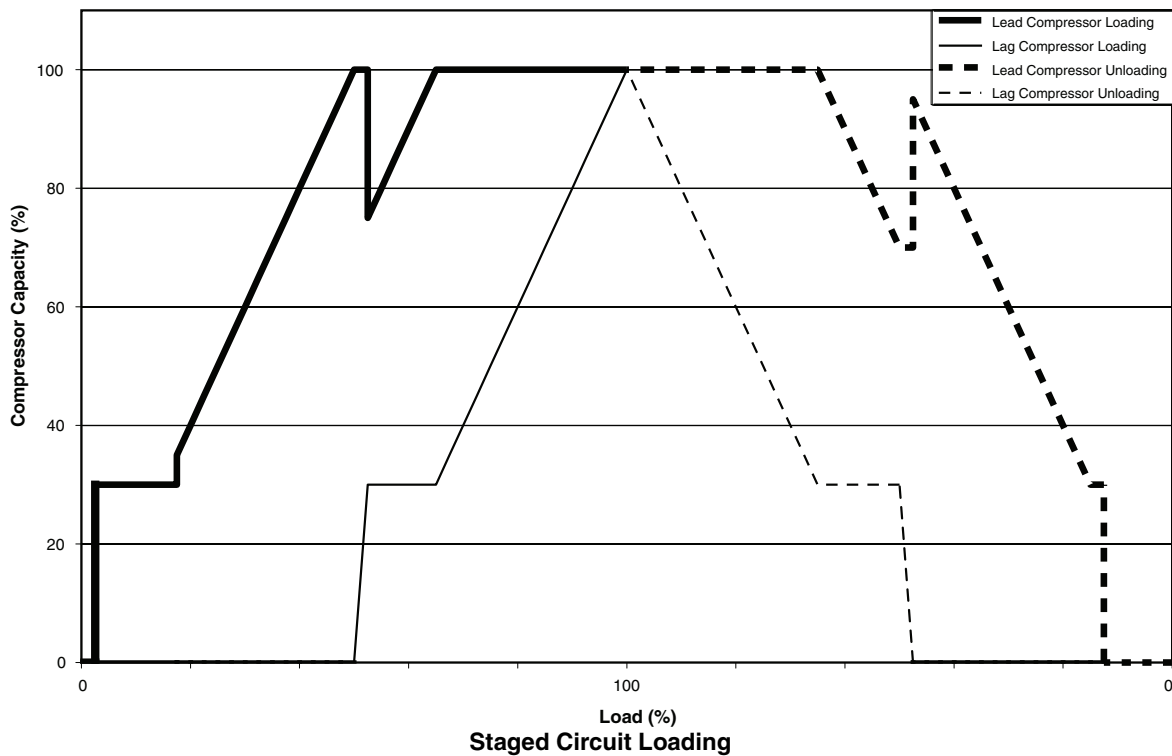
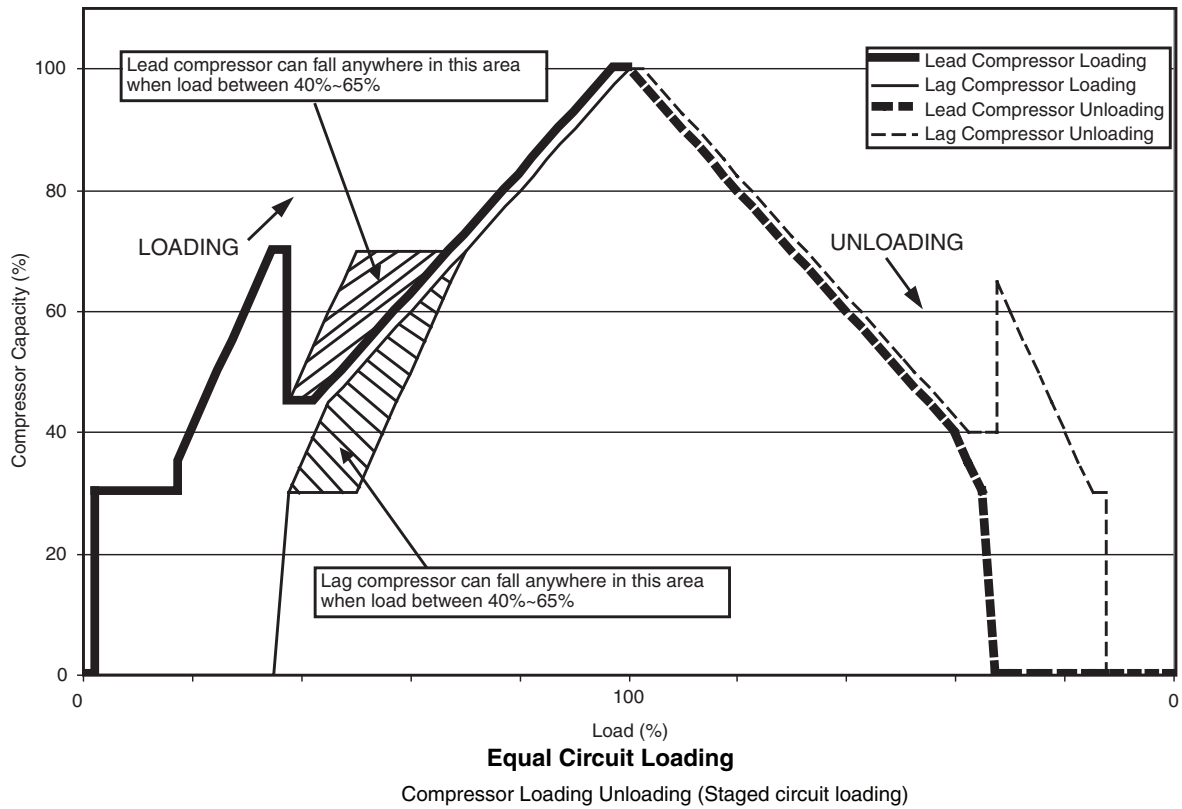
The control algorithm relies on several parameters that must be field configured for operation. Both chillers must be on the same Carrier Comfort Network® bus with different addresses. On both chillers, Master/Slave Select (**Master/Slave Select, MSSL**) must be enabled. The water piping arrangement, Chillers in Series (**Chiller in Series, SERI**), must be configured. The master chiller must be programmed with the Slave Chiller Address (**Slave Address, SLVA**). Additional optional programming parameters may be configured to meet application requirements.

Lead/Lag Balance Select (**Lead Lag Select, LLBL**) determines which chiller is the lead machine. The options are Always Lead, Lag if Fail, and Runtime Select. Under Runtime Select control, the lead chiller will change based on the time increment selected in the Lead/Lag Balance Delta configuration (**Lead/Lag Balance Data, LLBD**). If the run hour difference between the master and the slave remains less than the Lead/Lag Balance Delta, the chiller designated as the lead will remain the lead chiller. The Lead/Lag changeover between the master and the slave chiller due to hour balance will occur during chiller operating odd days, such as day 1, day 3, and day 5 of the month, at 12:00 a.m. If a lead chiller is not designated, the master chiller will always be designated the lead chiller.

The dual chiller control algorithm has the ability to delay the start of the lag chiller in two ways. The Lead Pulldown Time parameter (**Lead Pulldown Type, LPUL**) is a one-time time delay initiated after starting the lead chiller, before checking whether to start an additional chiller. This time delay gives the lead chiller a chance to remove the heat that the chilled water loop picked up while being inactive during an unoccupied period. The second time delay, Lead/Lag Delay (**Lag Start Timer, LLDY**) is a time delay imposed between the last stage of the lead chiller and the start of the lag chiller. This prevents enabling the lag chiller until the lead/lag delay timer has expired.

A quicker start of the lag chiller can be accomplished by configuring the Start if Error Higher parameter (**Start if Error Higher, LLER**). If the difference between the common leaving water temperature and the set point is greater than the configured value, then the lag chiller will start.

A minimum on time for the lag chiller can be programmed with the Lag Minimum Running Time configuration (**Lag Minimum Running Time, LAGM**). This parameter causes the control to run the lag chiller for the programmed minimum on time. The Lag Unit Pump Select (**Lag Unit Pump Control, LAGP**) can be configured such that the pump can be on or off while the chiller is off. This parameter is only active in Parallel Chiller Operation.



**Fig. 21 — Compressor Loading and Unloading**

For units with a Touch Pilot display, two additional steps must be completed to start the machine. On the master chiller, the Master Control Type must be configured for the start control defined in the Machine Control configuration. To start the machines, the master chiller must be started with the Start/Stop button and Master Mode selected. The slave chiller must be started with the CCN Mode selected.

Each application, Parallel and Series, are described separately below.

**DUAL CHILLER CONTROL FOR PARALLEL APPLICATIONS** — To configure the master chiller for parallel applications using the Touch Pilot display, see Table 28. To configure the master chiller for parallel applications using the Navigator display, see Table 29.

To configure the slave chiller for parallel applications using the Touch Pilot display, see Table 30. To configure the slave chiller for parallel applications using the Navigator display, see Table 31. A power cycle is required for the values to take effect.



**Table 28 — Dual Master Chiller Control Parameters for Parallel Applications with Touch Pilot™ Display**

DISPLAY NAME	PATH	LINE NO.	VALUE
Master/Slave Select	Main Menu→Config→MST_SLV	3	1 (Master) Default: 0 (Disable)
Master Control Type	Main Menu→Config→MST_SLV	7	1=Local Control 2=Remote Control 3=CCN Control Default: 1 Configure for proper control type.
Slave Address	Main Menu→Config→MST_SLV	11	Must be set to the Slave Chiller's address. The master and slave chiller must have different addresses and be on the same Bus Number Default: 2
Lead Lag Select	Main Menu→Config→MST_SLV	12	0 (Master Always Leads) 1 (Lag Once Failed Only) 2 (Lead/Lag Runtime Select) Default: 0 (Master Always Leads)
Lead/Lag Balance Delta	Main Menu→Config→MST_SLV	16	Range: 40 to 400 hours Default: 168 hours
Lag Start Timer	Main Menu→Config→MST_SLV	17	Range: 2 to 30 minutes Default: 10 minutes
Lead Pulldown Time	Main Menu→Config→MST_SLV	18	Range: 0 to 60 minutes Default: 0 minutes
Start If Error Higher	Main Menu→Config→MST_SLV	19	Range: 3.0 to 18 ΔF (1.7 to 10.0 ΔC) Default: 4.0 ΔF (2.2 ΔC)
Lag Minimum Running Time	Main Menu→Config→MST_SLV	20	Range: 0 to 150 minutes Default: 0 minutes
Lag Unit Pump Control	Main Menu→Config→MST_SLV	21	0 (Stop If Unit Stops) 1 (Run If Unit Stops) Default: 0 (Stop If Unit Stops)
Chiller In Series	Main Menu→Config→MST_SLV	22	Default: No Value: No

NOTE: If pump control is configured to OFF, then LAG UNIT PUMP SELECT = 1. If pump control is set to any other value, then LAG UNIT PUMP SELECT = 0. This configuration must be set consistently for both master and slave chillers.

**Table 29 — Dual Master Chiller Control Parameters for Parallel Applications with Navigator™ Display**

ITEM	ITEM EXPANSION	PATH	VALUE
MSSL	Master/Slave Select	Configuration→RSET	Master Default: Disable
SLVA	Slave Address	Configuration→RSET	Must be set to the Slave Chiller's address. The master and slave chiller must have different addresses and be on the same Bus Number Default: 2
LLBL	Master Lead Lag Select	Configuration→RSET	Range: Always Lead, Lag if Fail, Runtime Sel Default: Always Lead
LLBD	Lead/Lag Balance Delta	Configuration→RSET	Range: 40 to 400 hours Default: 168 hours
LLDY	Lag Start Delay	Configuration→RSET	Range: 2 to 30 minutes Default: 10 minutes
LL.ER	Start If Error Higher	Configuration→RSET	Range: 3.0 to 18 ΔF (1.7 to 10.0 ΔC) Default: 4.0 ΔF (2.2 ΔC)
LAG.M	Lag Unit Pump Select	Configuration→RSET	Range: Off If U Stp, On If U Stop Default: Off If U Stp
LPUL	Lead Pulldown Time	Configuration→RSET	Range: 0 to 60 minutes Default: 0 minutes
SERI	Chillers in Series	Configuration→RSET	No Default: No
OPER	Operating Control Type	Operating Modes→SLCT	Set to desired control

NOTE: If pump control is configured to OFF, then LAG UNIT PUMP SELECT = 1. If pump control is set to any other value, then LAG UNIT PUMP SELECT = 0. This configuration must be set consistently for both master and slave chillers.

**Table 30 — Dual Slave Chiller Control Parameters for Parallel Applications with Touch Pilot™ Display**

DISPLAY NAME	PATH	LINE NO.	VALUE
Master/Slave Select	Main Menu→Config→MST_SLV	3	2 (Slave) Default: 0 (Disable)
Master Control Type	Main Menu→Config→MST_SLV	7	1 (Local Control) 2 (Remote Control) 3 (CCN Control) Default: 1 Configure for proper control type.
Slave Address	Main Menu→Config→MST_SLV	11	Must be set to the Slave Chiller's address. The master and slave chiller must have different addresses and be on the same Bus Number Default: 2
Lead Lag Select	Main Menu→Config→MST_SLV	12	0 (Master Always Leads) 1 (Lag Once Failed Only) 2 (Lead/Lag Runtime Select) Default: 0 (Master Always Leads)
Lead/Lag Balance Delta	Main Menu→Config→MST_SLV	16	Range: 40 to 400 hours Default: 168 hours
Lag Start Timer	Main Menu→Config→MST_SLV	17	Range: 2 to 30 minutes Default: 10 minutes
Lead Pulldown Time	Main Menu→Config→MST_SLV	18	Range: 0 to 60 minutes Default: 0 minutes
Start If Error Higher	Main Menu→Config→MST_SLV	19	Range: 3.0 to 18 ΔF (1.7 to 10.0 ΔC) Default: 4.0 ΔF (2.2 ΔC)
Lag Minimum Running Time	Main Menu→Config→MST_SLV	20	Range: 0 to 150 minutes Default: 0 minutes
Lag Unit Pump Control	Main Menu→Config→MST_SLV	21	0 (Stop If Unit Stops) 1 (Run If Unit Stops) Default: 0 (Stop If Unit Stops)
Chiller In Series	Main Menu→Config→MST_SLV	22	No Default: No

NOTE: If pump control is configured to OFF, then LAG UNIT PUMP SELECT = 1. If pump control is set to any other value, then LAG UNIT PUMP SELECT = 0. This configuration must be set consistently for both master and slave chillers.

**Table 31 — Dual Slave Chiller Control Parameters for Parallel Applications with Navigator™ Display**

ITEM	ITEM EXPANSION	PATH	VALUE
MSSL	Master/Slave Select	Configuration→RSET	Slave Default: Disable
SLVA	Slave Address	Configuration→RSET	Must be set to the Slave Chiller's address. The master and slave chiller must have different addresses and be on the same Bus Number Default: 2
LLBL	Master Lead Lag Select	Configuration→RSET	Range: Always Lead, Lag if Fail, Runtime Sel Default: Always Lead
LLBD	Lead/Lag Balance Delta	Configuration→RSET	Range: 40 to 400 hours Default: 168 hours
LLDY	Lag Start Delay	Configuration→RSET	Range: 2 to 30 minutes Default: 10 minutes
LL.ER	Start If Error Higher	Configuration→RSET	Range: 3.0 to 18 ΔF (1.7 to 10.0 ΔC) Default: 4.0 ΔF (2.2 ΔC)
LAG.M	Lag Unit Pump Select	Configuration→RSET	Range: Off If U Stp, On If U Stop Default: Off If U Stp
LPUL	Lead Pulldown Time	Configuration→RSET	Range: 0 to 60 minutes Default: 0 minutes
SERI	Chillers in Series	Configuration→RSET	No, Default: No
OPER	Operating Control Type	Operating Modes→SLCT	CCN Control

NOTE: If pump control is configured to OFF, then LAG UNIT PUMP SELECT = 1. If pump control is set to any other value, then LAG UNIT PUMP SELECT = 0. This configuration must be set consistently for both master and slave chillers.

**DUAL CHILLER PUMP CONTROL FOR PARALLEL CHILLER APPLICATIONS** — It is recommended that a dedicated pump be used for each unit. The chiller must start and stop its own water pump located on its own piping. If pumps are not dedicated for each chiller, chiller isolation valves are required and each chiller must open and close its own isolation valve.

**DUAL CHILLER CONTROL FOR SERIES APPLICATIONS** — To configure the master chiller for series applications using the Touch Pilot™ display, see Table 32. To configure the master chiller for series applications using the Navigator™ display, see Table 33.

To configure the slave chiller for series applications using the Touch Pilot™ display, see Table 34. To configure the slave chiller for series applications using the Navigator™ display, see Table 35. A power cycle is required for the values to take effect.

**Table 32 — Dual Master Chiller Control Parameters for Series Applications with Touch Pilot™ Display**

DISPLAY NAME	PATH	LINE NO.	VALUE
Master/Slave Select	Main Menu→Config→MST_SLV	3	1 (Master) Default: 0 (Disable)
Master Control Type	Main Menu→Config→MST_SLV	7	1 (Local Control) 2 (Remote Control) 3 (CCN Control) Default: 1 (Local Control) Value: Configure for proper control type.
Slave Address	Main Menu→Config→MST_SLV	11	Must be set to the Slave Chiller's address. The master and slave chiller must have different addresses and be on the same Bus Number Default: 2
Lead Lag Select	Main Menu→Config→MST_SLV	12	0 (Master Always Leads) 1 (Lag Once Failed Only) 2 (Lead/Lag Runtime Select) Default: 0 (Master Always Leads)
Lead/Lag Balance Delta	Main Menu→Config→MST_SLV	16	Range: 40 to 400 hours Default: 168 hours
Lag Start Timer	Main Menu→Config→MST_SLV	17	Range: 2 to 30 minutes Default: 10 minutes
Lead Pulldown Time	Main Menu→Config→MST_SLV	18	Range: 0 to 60 minutes Default: 0 minutes
Start If Error Higher	Main Menu→Config→MST_SLV	19	Range: 3.0 to 18 ΔF (1.7 to 10.0 ΔC) Default: 4.0Δ F (2.2 ΔC)
Lag Minimum Running Time	Main Menu→Config→MST_SLV	20	Range: 0 to 150 minutes Default: 0 minutes
Lag Unit Pump Control	Main Menu→Config→MST_SLV	21	0 (Stop If Unit Stops) 1 (Run If Unit Stops) Default: 0 (Stop If Unit Stops)
Chiller In Series	Main Menu→Config→MST_SLV	22	Yes Default: No

NOTE: If pump control is configured to OFF, then LAG UNIT PUMP SELECT = 1. If pump control is set to any other value, then LAG

UNIT PUMP SELECT = 0. This configuration must be set consistently for both master and slave chillers.

**Table 33 — Dual Master Chiller Control Parameters for Series Applications with Navigator™ Display**

ITEM	ITEM EXPANSION	PATH	VALUE
MSSL	Master/Slave Select	Configuration→RSET	Master Default: Disable
SLVA	Slave Address	Configuration→RSET	Must be set to the Slave Chiller's address. The master and slave chiller must have different addresses and be on the same Bus Number Default: 2
LLBL	Master Lead Lag Select	Configuration→RSET	Range: Always Lead, Lag if Fail, Runtime Sel Default: Always Lead
LLBD	Lead/Lag Balance Delta	Configuration→RSET	Range: 40 to 400 hours Default: 168 hours
LLDY	Lag Start Delay	Configuration→RSET	Range: 2 to 30 minutes Default: 10 minutes
LL.ER	Start If Error Higher	Configuration→RSET	Range: 3.0 to 18 ΔF (1.7 to 10.0 ΔC) Default: 4.0 ΔF (2.2 ΔC)
LAG.M	Lag Unit Pump Select	Configuration→RSET	Range: Off If U Stp, On If U Stop Default: Off If U Stp
LPUL	Lead Pulldown Time	Configuration→RSET	Range: 0 to 60 minutes Default: 0 minutes
SERI	Chillers in Series	Configuration→RSET	YES Default: NO
OPER	Operating Control Type	Operating Modes→SLCT	Set to desired value

NOTE: If pump control is configured to OFF, then LAG UNIT PUMP SELECT = 1. If pump control is set to any other value, then LAG UNIT PUMP SELECT = 0. This configuration must be set consistently for both master and slave chillers.

**Table 34 — Dual Slave Chiller Control Parameters for Series Applications with Touch Pilot Display**

DISPLAY NAME	PATH	LINE NO.	VALUE
Master/Slave Select	Main Menu→Config→MST_SLV	3	2 (Slave) Default: 0 (Disable)
Master Control Type	Main Menu→Config→MST_SLV	7	1 (Local Control) 2 (Remote Control) 3 (CCN Control) Default: 1 (Local Control) Value: Configure for proper control type.
Slave Address	Main Menu→Config→MST_SLV	11	Must be set to the Slave Chiller's address. The master and slave chiller must have different addresses and be on the same Bus Number Default: 2
Lead Lag Select	Main Menu→Config→MST_SLV	12	0 (Master Always Leads) 1 (Lag Once Failed Only) 2 (Lead/Lag Runtime Select) Default: 0 (Master Always Leads)
Lead/Lag Balance Delta	Main Menu→Config→MST_SLV	16	Range: 40 to 400 hours Default: 168 hours
Lag Start Timer	Main Menu→Config→MST_SLV	17	Range: 2 to 30 minutes Default: 10 minutes
Lead Pulldown Time	Main Menu→Config→MST_SLV	18	Range: 0 to 60 minutes Default: 0 minutes
Start If Error Higher	Main Menu→Config→MST_SLV	19	Range: 3.0 to 18 ΔF (1.7 to 10.0 ΔC) Default: 4.0 ΔF (2.2 ΔC)
Lag Minimum Running Time	Main Menu→Config→MST_SLV	20	Range: 0 to 150 minutes Default: 0 minutes
Lag Unit Pump Control	Main Menu→Config→MST_SLV	21	0 (Stop If Unit Stops) 1 (Run If Unit Stops) Default: 0 (Stop If Unit Stops)
Chiller In Series	Main Menu→Config→MST_SLV	22	Yes Default: No

NOTE: If pump control is configured to OFF, then LAG UNIT PUMP SELECT = 1. If pump control is set to any other value, then LAG

UNIT PUMP SELECT = 0. This configuration must be set consistently for both master and slave chillers.

**Table 35 — Dual Slave Chiller Control Parameters for Series Applications with Navigator Display**

ITEM	ITEM EXPANSION	PATH	VALUE
MSSL	Master/Slave Select	Configuration→RSET	Slave Default: Disable
SLVA	Slave Address	Configuration→RSET	Must be set to the Slave Chiller's address. The master and slave chiller must have different addresses and be on the same Bus Number Default: 2
LLBL	Master Lead Lag Select	Configuration→RSET	Range: Always Lead, Lag if Fail, Runtime Sel Default: Always Lead
LLBD	Lead/Lag Balance Delta	Configuration→RSET	Range: 40 to 400 hours Default: 168 hours
LLDY	Lag Start Delay	Configuration→RSET	Range: 2 to 30 minutes Default: 10 minutes
LL.ER	Start If Error Higher	Configuration→RSET	Range: 3.0 to 18 ΔF (1.7 to 10.0 ΔC) Default: 4.0 ΔF (2.2 ΔC)
LAG.M	Lag Unit Pump Select	Configuration→RSET	Range: Off If U Stp, On If U Stop Default: Off If U Stp
LPUL	Lead Pulldown Time	Configuration→RSET	Range: 0 to 60 minutes Default: 0 minutes
SERI	Chillers in Series	Configuration→RSET	YES Default: NO
OPER	Operating Control Type	Operating Modes→SLCT	CCN Control

NOTE: If pump control is configured to OFF, then LAG UNIT PUMP SELECT = 1. If pump control is set to any other value, then LAG UNIT PUMP SELECT = 0. This configuration must be set consistently for both master and slave chillers.

**DUAL CHILLER PUMP CONTROL FOR SERIES CHILLER APPLICATIONS** — Pump control for series chiller applications is controlled by the master chiller only. The control of the slave chiller is directed through commands emitted by the master chiller. The slave chiller has no action in master/slave operations. The slave chiller only verifies that CCN communication with the master chiller is present. See the Dual Chiller Sequence of Operation section on page 68.

**Night Time/Low Noise Operation** — The *ComfortLink™* controls have the ability to lower the sound level of the machine by reducing the number of fans that are running, provided that the conditions are acceptable. Reducing the number of running fans also limits the capacity. Three parameters must be configured for this operation. A start and end time for the mode of operation is required and an optional capacity limit set point must also be configured.

If the Start and End Time remain at the factory default (0:00), then the unit is not programmed for Night Time/Low Noise Operation.

To configure this option with the Touch Pilot™ display:

DISPLAY NAME	PATH	LINE NO.	VALUE
Start Hour	Main Menu→Config→User	39	Default: 00:00
End Hour	Main Menu→Config→User	40	Default: 00:00
Capacity Limit	Main Menu→Config→User	41	Default: 100%

To configure this option with the Navigator™ display:

ITEM	ITEM EXPANSION	PATH	VALUE
LS.ST	Night Low Noise Start	Configuration→OPTN	Default: 00:00
LS.ND	Night Low Noise End	Configuration→OPTN	Default: 00:00
LS.LT	Low Noise Capacity Lim	Configuration→OPTN	Default: 100%

**Ramp Loading** — Ramp Loading limits the rate of change of the leaving fluid temperature. If the unit is in a Cooling mode and configured for Ramp Loading Select (**Ramp Loading Select, RLS**), the control makes two comparisons before deciding to increase capacity. First, the control calculates the temperature difference between the control point and leaving fluid temperature. If the difference is greater than 4° F (2.2° C) and the rate of change (°F or °C per minute) is more than the configured Cool Ramp Loading rate (**Cooling Ramp Loading, CRMP**), then the control does not allow any increase of capacity.

To configure this option with the Touch Pilot display:

DISPLAY NAME	PATH	LINE NO.	VALUE
Ramp Loading Select	Main Menu→Config→USER	5	Yes
Cooling Ramp Loading	Main Menu→Setpoint	14	Range: 0.2 to 2.0 °F (0.1 to 1.1 °C) Default: 1.0 °F (0.5 °C)

To configure this option with the Navigator display:

ITEM	ITEM EXPANSION	PATH	VALUE
RL.S	Ramp Load Select	Configuration→OPTN	Yes
CRMP	Cool Ramp Loading	Setpoints→COOL	Range: 0.2 to 2.0 °F (0.1 to 1.1 °C) Default: 1.0 °F (0.5 °C)

**Temperature Reset** — Temperature reset is a value added to the basic leaving fluid temperature set point and the resulting sum of these values is the new control point. When a non-zero temperature reset is applied, the chiller controls to the new control point, not the set point. The type of temperature reset is configured with the Cooling Reset Type (**Cooling Reset Select, CRST**) variable. Four types of temperature reset are available: Return Water Reset, Outside Air Temperature Reset, Space Temperature Reset, and 4-20 mA Temperature Reset.

Under normal operation, the chiller will maintain a constant entering or leaving fluid temperature, based on the configuration, approximately equal to the chilled fluid set point. As the cooler load varies, the cooler fluid temperature difference will change in proportion to the load. For example, if the chiller was selected for a Entering to Leaving Water Temperature difference of 10 F (5.5 C) at full load, at 50% load the temperature difference would be 5 F (2.2 C). See Fig. 22. Because the change in temperature through the cooler is a measure of the building load, the temperature difference reset is the average building load. Usually the chiller size and fluid temperature set point are selected based on a full load condition. At part load, the fluid temperature set point may be lower than required. If the fluid temperature were allowed to increase at part load, the efficiency of the machine would increase. The chiller can also be set for return water temperature control. See Fig. 23.

Other indirect means of estimating building load and controlling temperature reset are also available and are discussed below.

To verify that reset is functioning correctly, subtract the Setpoint Select (**Current Setpoint, SETP**) from the Control Point (**Control Point, CTPT**) to determine the degrees reset.

**RETURN WATER RESET** — The control system is capable of performing fluid temperature reset based on cooler fluid temperature difference. Because the change in temperature through the cooler is a measure of the building load, the temperature difference reset is, in effect, an average building load reset method.

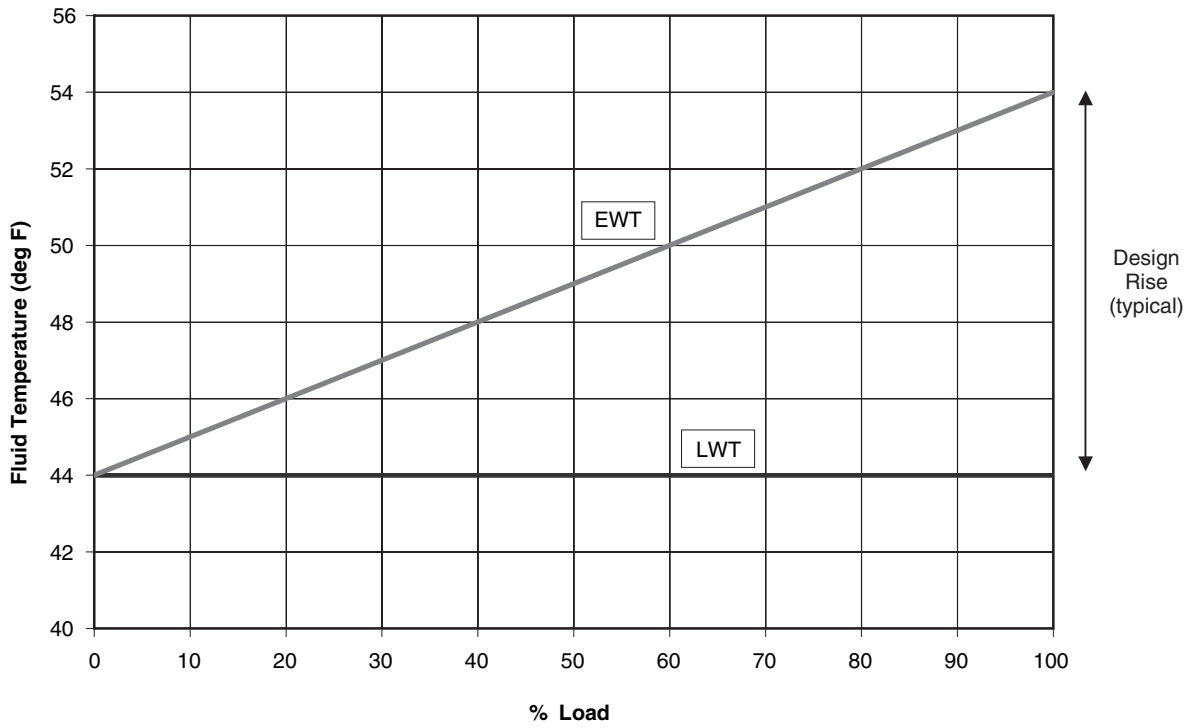
Return Water Temperature Reset allows for the chilled water temperature set point to be reset upward as a function of the fluid temperature difference (building load).

NOTE: Return Water Temperature Reset should not be used with variable cooler flow rate systems.

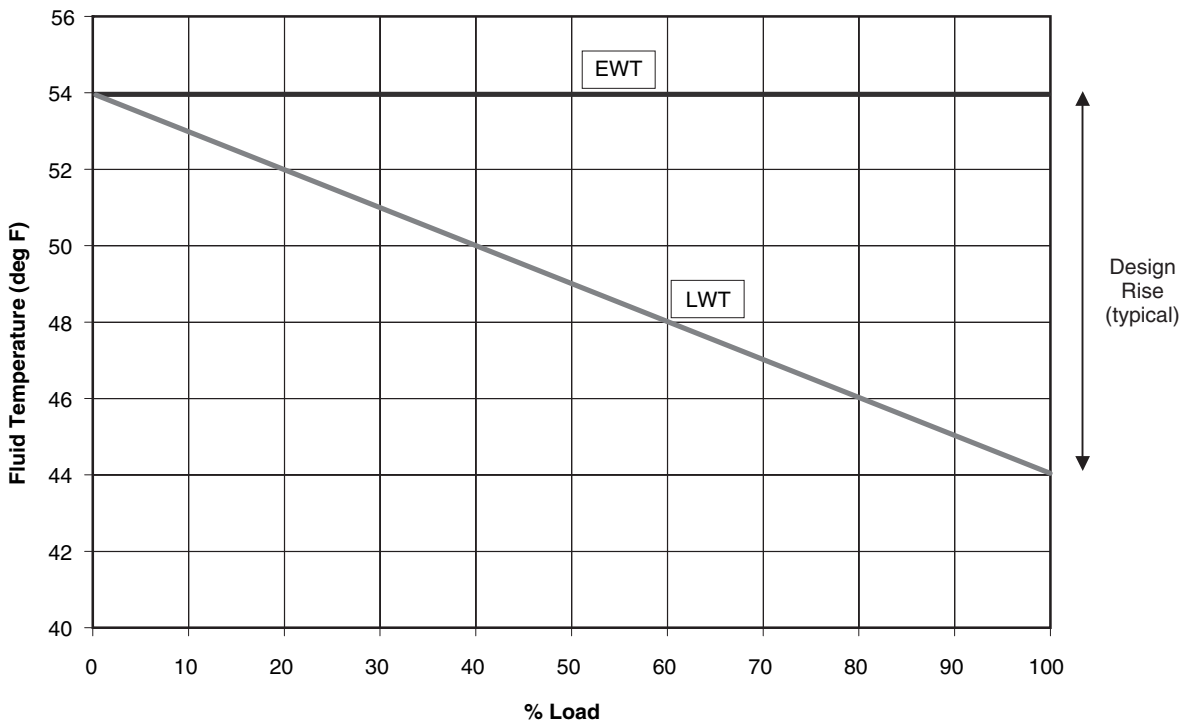
To use Return Water Temperature Reset, four variables must be configured. Cooling Reset Type (**Cooling Reset Select, CRST**) must be enabled. The variable Delta T No Reset Temp (**Delta T No Reset Value, CRT1**) should be set to the cooler temperature difference (T) where no chilled water temperature reset should occur. The variable Delta T Full Reset Temp (**Delta T Full Reset Value, CRT2**) should be set to the cooler temperature difference where the maximum chilled water temperature reset should occur. The variable Degrees Cool Reset (**Cooling Reset Deg. Value, DGRC**) should be set to the maximum amount of reset desired.

To configure this option with the Touch Pilot display:

DISPLAY NAME	PATH	LINE NO.	VALUE
Cooling Reset Select	Main Menu→Config→USER	19	Default =0 (No Reset) 2 (Delta T)
Delta T No Reset Temp	Main Menu→Setpoint→SETPOINT	7	Default = 0 F (0 C)
Delta T Full Reset Temp	Main Menu→Setpoint→SETPOINT	8	Default = 0 F (0 C)
Cooling Reset Deg. Value	Main Menu→Setpoint→SETPOINT	13	Default = 0 F (0 C)



**Fig. 22 — Leaving Chilled Water Temperature Control**



**Fig. 23 — Return Water Temperature Control Load Profile**



To configure this option with the Navigator™ display:

ITEM	ITEM EXPANSION	PATH	VALUE
CRST	Cooling Reset Type	Configuration→RSET	Default = No Reset Delta T Temp
CRT1	Delta T No Reset Temp	Setpoints→COOL	Default = 0 F (0 C)
CRT2	Delta T Full Reset Temp	Setpoints→COOL	Default = 0 F (0 C)
DGRC	Degrees Cool Reset	Setpoints→COOL	Default = 0 F (0 C)

In the example in Fig. 24 using Return Water Temperature Reset, the chilled water temperature will be reset by 5° F (2.8° C) when the Fluid Temperature Difference is 2° F (1.1° C) and 0° F (0° C) reset when the Temperature Difference is 10° F.

**OUTSIDE AIR TEMPERATURE RESET** — The control system is also capable of temperature reset based on outdoor-air temperature (OAT).

To use Outdoor Air Temperature Reset, four variables must be configured. Cooling Reset Type (**Cooling Reset Select, CRST**) must be enabled. The outside temperature at which no temperature reset is required, OAT No Reset Temp (**OAT No Reset Value, CRO1**) must be set. The outside temperature at which full temperature reset is required, OAT Full Reset Temp (**OAT Full Reset Value, CRO2**) must be set. Finally, the amount of temperature reset desired, Degrees Cool Reset (**Cooling Reset Deg. Value, DRGC**) must be set.

To configure this option with the Touch Pilot™ display:

DISPLAY NAME	PATH	LINE NO.	VALUE
Cooling Reset Select	Main Menu→Config→USER	19	Default = 0 (No Reset) 1 (OAT)
OAT No Reset Value	Main Menu→Setpoint→SETPOINT	5	Default = 14 F (-10 C)
OAT Full Reset Value	Main Menu→Setpoint→SETPOINT	6	Default = 14 F (-10 C)
Cooling Reset Deg. Value	Main Menu→Setpoint→SETPOINT	13	Default = 0 F (0 C)

To configure this option with the Navigator display:

ITEM	ITEM EXPANSION	PATH	VALUE
CRST	Cooling Reset Type	Configuration→RSET	Default = No Reset Out Air Temp
CRO1	OAT No Reset Temp	Setpoints→COOL	Default = 14 F (-10 C)
CRO2	OAT Full Reset Temp	Setpoints→COOL	Default = 14 F (-10 C)
DGRC	Degrees Cool Reset	Setpoints→COOL	Default = 0 F (0 C)

In the example in Fig. 25, the outdoor air temperature reset example provides 0° F (0° C) chilled water set point reset at 85 F (29.4 C) outdoor-air temperature and 15° F (8.3° C) reset at 55 F (12.8 C) outdoor-air temperature.

**SPACE TEMPERATURE RESET** — The control system is also capable of temperature reset based on space temperature (SPT). An accessory sensor must be used for SPT reset (33ZCT55SPT). The Energy Management Module (EMM) is also required for temperature reset using space temperature.

To use Space Temperature Reset, four variables must be configured. Cooling Reset Type (**Cooling Reset Select, CRST**) must be enabled. The space temperature at which no temperature reset is required, Space T No Reset Temp (**Space T No Reset Value, CRS1**) must be set. The space temperature at which full temperature reset is required, Space T Full Reset Temp (**Space T Full Reset Value, CRS2**) must be set. Finally, the amount of temperature reset desired, Degrees Cool Reset (**Cooling Reset Deg. Value, DRGC**), must be set.

To configure this option with the Touch Pilot display:

DISPLAY NAME	PATH	LINE NO.	VALUE
Cooling Reset Select	Main Menu →Config→USER	19	Default = 0 (No Reset) 4 (Space Temp)
Space T No Reset Value	Main Menu →Setpoint→SETPOINT	11	Default = 14 F (-10 C)
Space T Full Reset Value	Main Menu →Setpoint→SETPOINT	12	Default = 14 F (-10 C)
Cooling Reset Deg. Value	Main Menu →Setpoint→SETPOINT	13	Default = 0 F (0 C)

To configure this option with the Navigator display:

ITEM	ITEM EXPANSION	PATH	VALUE
CRST	Cooling Reset Type	Configuration→RSET	Default = No Reset Space Temp
CRS1	Space T No Reset Temp	Setpoints→COOL	Default = 14 F (-10 C)
CRS2	Space T Full Reset Temp	Setpoints→COOL	Default = 14 F (-10 C)
DGRC	Degrees Cool Reset	Setpoints→COOL	Default = 0 F (0 C)

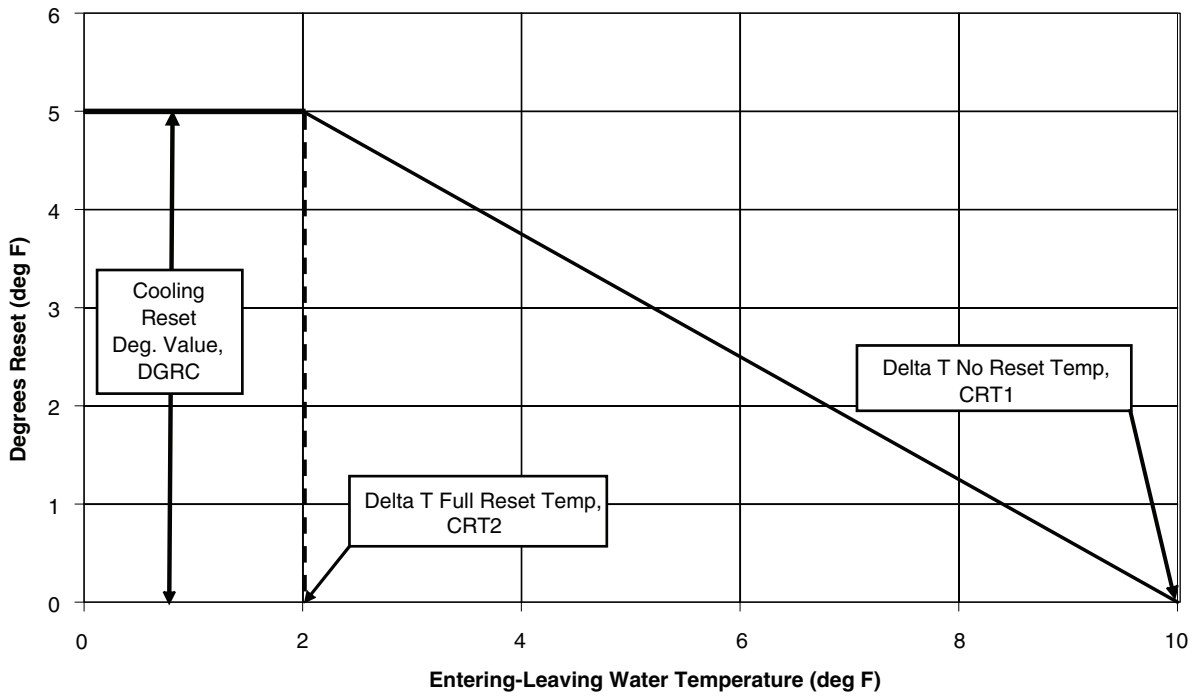
In the space temperature reset example in Fig. 26, 0° F (0° C) chilled water set point reset at 72 F (22.2 C) space temperature and 6° F (3.3° C) reset at 68 F (20.0 C) space temperature.

**4-20 mA TEMPERATURE RESET** — The control system is also capable of temperature reset based on an externally powered 4 to 20 mA signal. The Energy Management Module (EMM) is required for temperature reset using a 4 to 20 mA signal.

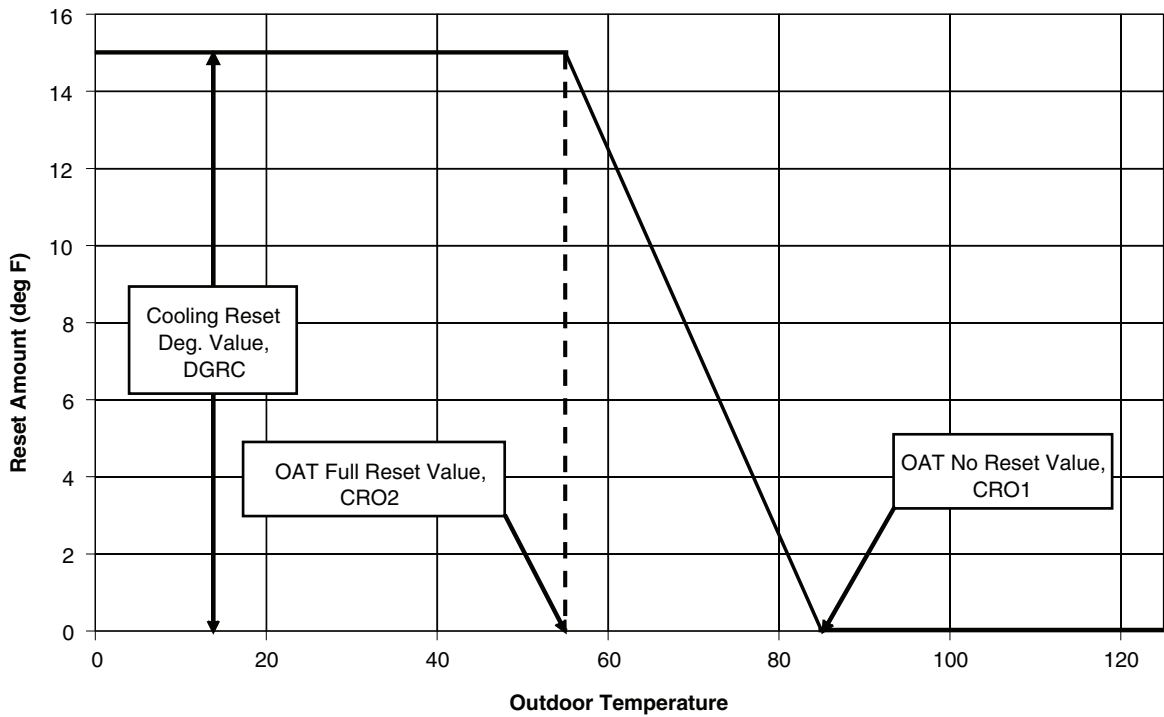
To use 4-20 mA Temperature Reset, four variables must be configured. Cooling Reset Type (**Cooling Reset Select, CRST**) must be enabled. The milliamp signal at which no temperature reset is required, Current No Reset Value (**Current No Reset Value, CRV1**), must be set. The milliamp signal at which full temperature reset is required, Current Full Reset Value (**Current Full Reset Value, CRV2**), must be set. Finally, the amount of temperature reset desired, Degrees Cool Reset (**Cooling Reset Deg. Value, DRGC**), must be set.

### CAUTION

Care should be taken when interfacing with other control systems due to possible power supply differences such as a full wave bridge versus a half wave rectification. Connection of control devices with different power supplies may result in permanent damage. The *ComfortLink™* controls incorporate power supplies with half wave rectification. A signal isolation device should be utilized if the signal generator incorporates a full wave bridge rectifier.



**Fig. 24 — Return Water Reset**



**Fig. 25 — OAT Temperature Reset**

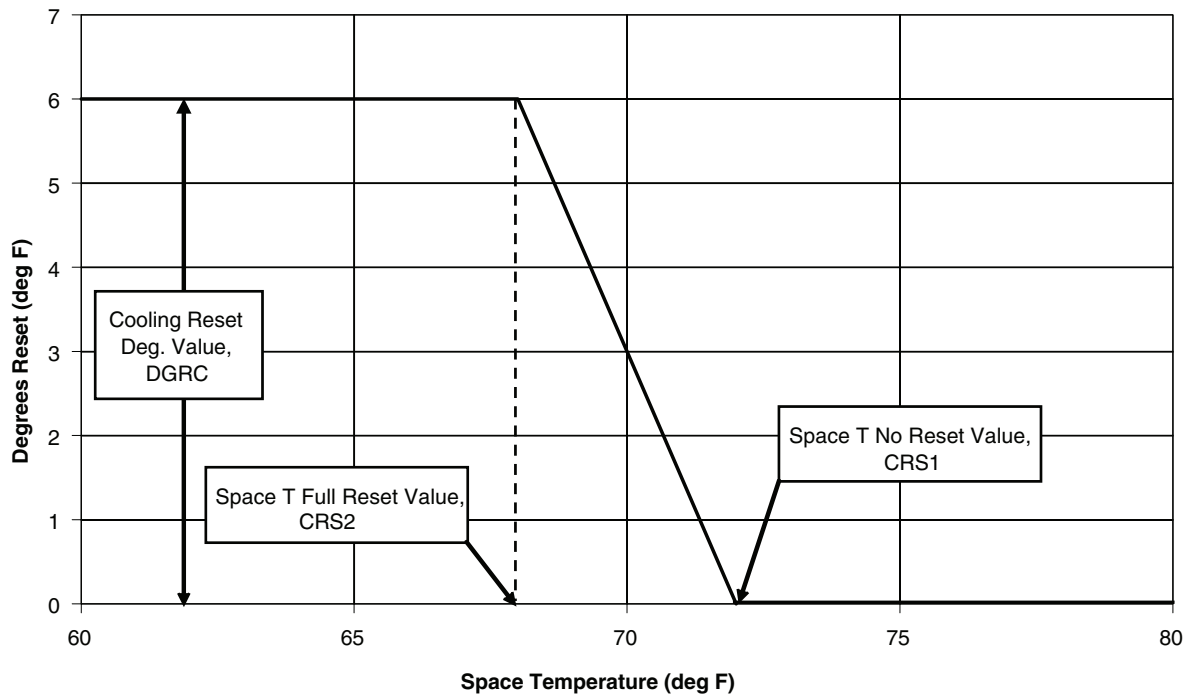


Fig. 26 — Space Temperature Reset

To configure this option with the Touch Pilot™ display:

DISPLAY NAME	PATH	LINE NO.	VALUE
Cooling Reset Select	Main Menu →Config→USER	19	Default =0 (No Reset) 3 (4-20mA Control)
Current No Reset Value	Main Menu →Setpoint→SETPOINT	9	4.0 mA Default = 0.0
Current Full Reset Value	Main Menu →Setpoint→SETPOINT	10	30.0 mA Default = 0.0
Cooling Reset Deg. Value	Main Menu →Setpoint→SETPOINT	13	Default = 0.0 F (0.0 C)

To configure this option with the Navigator™ display:

ITEM	ITEM EXPANSION	PATH	VALUE
CRST	Cooling Reset Type	Configuration→RSET	Default = No Reset 4-20mA Input
CRV1	Current No Reset Temp	Setpoints→COOL	4.0 mA Default = 0.0
CRV2	Current Full Reset Temp	Setpoints→COOL	20.0 mA Default = 0.0
DGRC	Degrees Cool Reset	Setpoints→COOL	5.0 F (2.8 C) Default = 0.0

In the example in Fig. 27, at 4 mA no reset takes place and at 20 mA, 5° F (2.8° C) chilled water set point reset is required.

**Demand Limit** — Demand limit is a feature that allows the unit capacity to be limited during periods of peak energy usage. This allows the owner to keep energy costs down. There are three types of demand limiting that can be configured. The first type is through 2-step switch control, which will reduce the maximum capacity to 2 user configurable percentages. The second type is by 4 to 20 mA signal input which will reduce the

maximum capacity linearly between 100% at a 4 mA input signal (no reduction) down to the user-configurable level at a 20 mA input signal. The third type uses the CCN Loadshed module and has the ability to limit the current operating capacity to maximum and further reduce the capacity if required. Demand limit control can be based on a calculated capacity level or by compressor current level.

NOTE: If using the compressor current level for demand limit, take into account the other power draws such as the condenser-fan motors when determining the limit value desired.

**SWITCH CONTROLLED DEMAND LIMIT** — The control system is capable of demand limit based on a field-supplied switch for 1-step demand limit or 2 switches for 2-step demand limit. One-step Demand Limit is standard. The 2-step switch control of demand limiting requires the Energy Management Module (EMM). Demand Limit steps are controlled by two relay switch inputs field wired to TB5-5 and TB5-14 for Switch 1 and TB6-14 and TB6-15 for Switch 2.

For demand limit by switch control, closing the first demand limit contact will put the unit on the first demand limit level, either by capacity or compressor current. The unit will not exceed the percentage of capacity or compressor current entered as Demand Limit Switch 1 set point. Closing contacts on the second demand limit switch prevents the unit from exceeding the demand limit entered as Demand Limit Switch 2 set point. The demand limit percent capacity or compressor current that is set to the lowest demand takes priority if both demand limit inputs are closed. If the demand limit percentage does not match unit operation, the unit will limit capacity or current to the closest step without exceeding the value.

To use Demand Limit, select the type of demand limiting to use by configuring the Demand Limit Select variable (**Demand Limit Type Select, DMDC**) to Switch. Configure the Demand Limit set points based on the type selected.

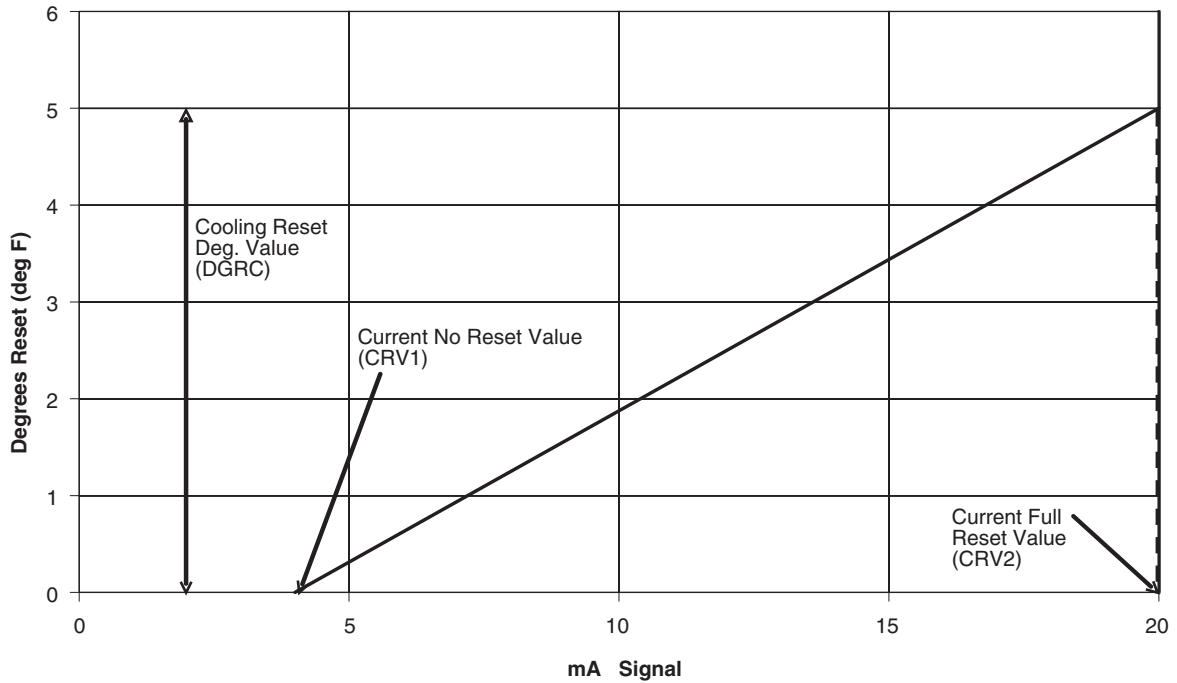


Fig. 27 — 4 to 20 mA Temperature Reset

**Switch Controlled (Capacity Based)** — If using 2-step Demand Limit control, an Energy Management Module must be installed. One-step Demand Limit control does not require the Energy Management Module. To configure Demand Limit for switch control, three parameters for 1-step switch control must be configured. For 2-step control, four parameters must be configured. The parameters are: the type of Demand Limit Selection (**Demand Limit Type Select, DMDC**), the setting for Switch Limit Set Point 1 (**Switch Limit Setpoint 1, DLS1**), The setting for Switch Limit Set Point 2 (**Switch Limit Setpoint 2, DLS2**), and Current Limit Select (**Current Limit Select, CUR.S**). Current Limit Select must be set to NO.

To configure this option with the Touch Pilot™ display:

DISPLAY NAME	PATH	LINE NO.	VALUE
Demand Limit Type Select	Config→USER	24	1 (Switch Control) Default = 0 (None)
Switch Limit Setpoint 1	Setpoints→SETPOINT	33	Default = 100%
Switch Limit Setpoint 2	Setpoints→SETPOINT	34	(Not required for 1-Step) Default = 100%
Current Limit Select	Config→USER	30	No Default = No

To configure this option with the Navigator™ display:

ITEM	ITEM EXPANSION	PATH	VALUE
DMDC	Demand Limit Select	Configuration→RSET	SWITCH Default = NONE
DLS1	Switch Limit Setpoint 1	Setpoints→MISC	Default = 100%
DLS2	Switch Limit Setpoint 2	Setpoints→MISC	(Not required for 1-Step) Default = 100%
CUR.S	Current Limit Select	Configuration→OPTN	NO Default: NO

In the following example, 2-step demand limit based on capacity is desired with the first switch closure limiting the capacity to 60%. The second switch closure is to limit the

capacity to 40%. Demand Limit Switch 1 is 60% and Demand Limit Switch 2 is 40%.

TOUCH PILOT DISPLAY		NAVIGATOR DISPLAY	
Display Name	Value	Item	Value
Demand Limit Type Select	1	DMDC	SWITCH
Switch Limit Setpoint 1	60%	DSL1	60%
Switch Limit Setpoint 2	40%	DSL2	40%
Current Limit Select	No	CUR.S	NO

**Switch Controlled (Current Based)** — If using 2-step demand limit control, an Energy Management Module must be installed. One-step demand limit control does not require the Energy Management Module. Four parameters for 1-step switch control must be configured. For 2-step control, five parameters must be configured. The parameters are: the type of Demand Limit Selection (**Demand Limit Type Select, DMDC**), the setting for Switch Limit Set Point 1 (**Switch Limit Setpoint 1, DLS1**), the setting for Switch Limit Set Point 2 (**Switch Limit Setpoint 2, DLS2**), the Current Limit Select (**Current Limit Select, CUR.S**), and the Compressor Current limit at 100% signal, (**Current Limit at 100%, CUR.F**).

To configure this option with the Touch Pilot display:

DISPLAY NAME	PATH	LINE NO.	VALUE
Demand Limit Type Select	Config→USER	24	1 (Switch Control) Default = 0 (None)
Switch Limit Setpoint 1	Setpoints→SETPOINT	33	Default = 100%
Switch Limit Setpoint 2	Setpoints→SETPOINT	34	(Not required for 1-Step) Default = 100%
Current Limit Select	Config→USER	30	Yes Default = No
Current Limit at 100%	Config→USER	31	Default = 2000.0 Amps

To configure this option with the Navigator™ display:

ITEM	ITEM EXPANSION	PATH	VALUE
<b>DMDC</b>	Demand Limit Select	Configuration→RSET	SWITCH Default = NONE
<b>DSL1</b>	Switch Limit Setpoint 1	Setpoints→MISC	Default = 100%
<b>DSL2</b>	Switch Limit Setpoint 2	Setpoints→MISC	(Not required for 1-Step) Default = 100%
<b>CUR.S</b>	Current Limit Select	Configuration→OPTN	NO Default: NO
<b>CUR.F</b>	Current Limit at 100%	Configuration→OPTN	Default = 2000

EXTERNALLY POWERED (4 to 20 mA) CAPACITY BASED DEMAND LIMIT — The Energy Management Module is required for 4 to 20 mA demand limit control. An externally powered 4 to 20 mA signal must be connected to TB6-1 and TB6-2. To configure demand limit for 4 to 20 mA control based on unit capacity, four parameters must be configured. The parameters are: the type of Demand Limit Selection (**Demand Limit Type Select, DMDC**), the current at which 100% capacity limit takes place (**mA For 100% Demand Limit, DMMX**), the current at which 0% capacity limit takes place (**mA For 0% Demand Limit, DMZE**), and the Current Limit Selection (**Current Limit Select, CUR.S**).

**CAUTION**

Care should be taken when interfacing with other control systems due to possible power supply differences such as a full wave bridge versus a half wave rectification. Connection of control devices with different power supplies may result in permanent damage. *ComfortLink™* controls incorporate power supplies with half wave rectification. A signal isolation device should be utilized if the signal generator incorporates a full wave bridge rectifier.

To configure this option with the Touch Pilot™ display:

DISPLAY NAME	PATH	LINE NO.	VALUE
<b>Demand Limit Type Select</b>	Config→USER	24	2 (4-20mA Control) Default = 0 (None)
<b>mA For 100% Demand Limit</b>	Config→USER	28	4.0 mA Default = 0.0 mA
<b>mA For 0% Demand Limit</b>	Config→USER	29	20.0 mA Default = 10.0 mA
<b>Current Limit Select</b>	Config→USER	30	No Default = No

To configure this option with the Navigator display:

ITEM	ITEM EXPANSION	PATH	VALUE
<b>DMDC</b>	Demand Limit Select	Config→RSET	4-20MA INPUT Default = NONE
<b>DMMX</b>	mA for 100% Demand Lim	Config→RSET	4.0 mA Default = 0.0 mA
<b>DMZE</b>	mA for 0% Demand Limit	Config→RSET	20.0 mA Default = 10.0 mA
<b>CUR.S</b>	Current Limit Select	Config→OPTN	NO Default: NO

In the following example, a 4 mA signal is Demand Limit 100% and a 20 mA Demand Limit signal is 0%. The 4 to

20 mA signal is connected to TB6-1 and TB6-2. The demand limit is a linear interpolation between the two values entered. In Fig. 28, if the machine receives a 12 mA signal, the machine controls will limit the capacity to 50%.

EXTERNALLY POWERED (4 to 20 mA) CURRENT BASED DEMAND LIMIT — The Energy Management Module is required for 4 to 20 mA demand limit control. An externally powered 4 to 20 mA signal must be connected to TB6-1 and TB6-2. To configure demand limit for 4 to 20 mA control based on compressor current, five parameters must be configured. The parameters are: the type of Demand Limit Selection (**Demand Limit Type Select, DMDC**), the current at which 100% capacity limit takes place (**mA For 100% Demand Limit, DMMX**), the current at which 0% capacity limit takes place (**mA For 0% Demand Limit, DMZE**), the Current Limit Selection (**Current Limit Select, CUR.S**), and the Compressor Current limit at 100% signal (**Current Limit at 100%, CUR.F**).

**CAUTION**

Care should be taken when interfacing with other control systems due to possible power supply differences such as a full wave bridge versus a half wave rectification. Connection of control devices with different power supplies may result in permanent damage. *ComfortLink* controls incorporate power supplies with half wave rectification. A signal isolation device should be utilized if the signal generator incorporates a full wave bridge rectifier.

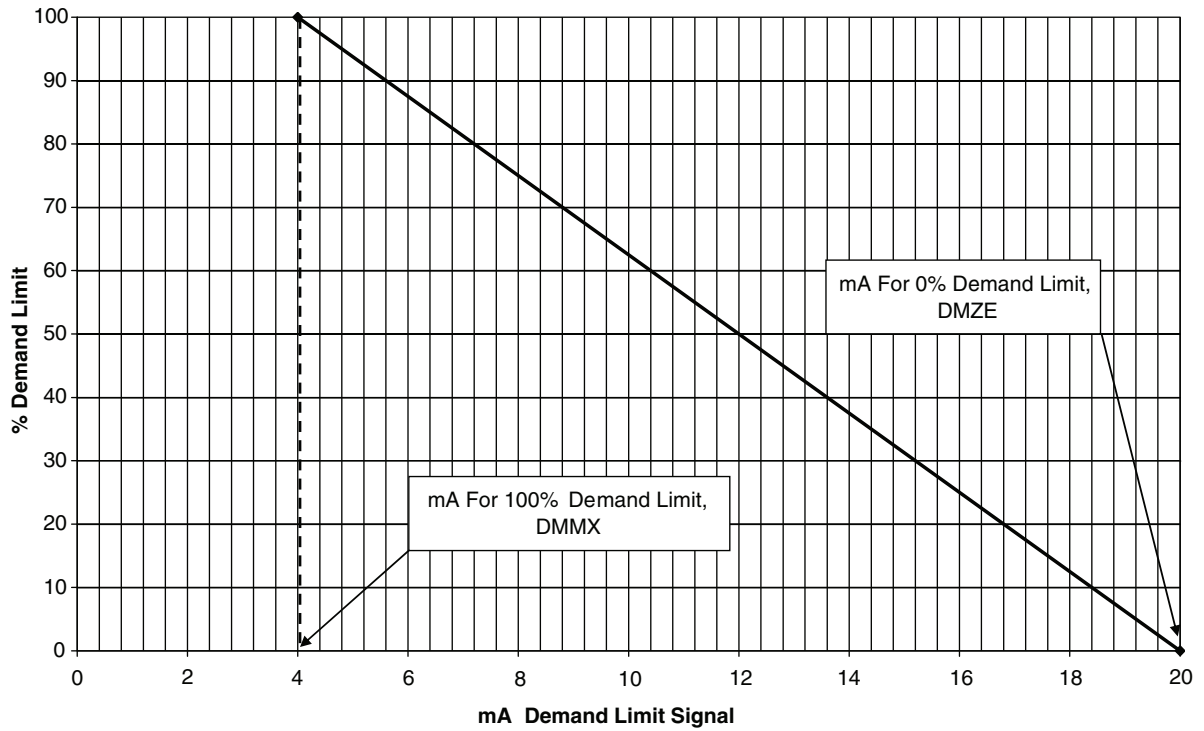
To configure this option with the Touch Pilot display:

DISPLAY NAME	PATH	LINE NO.	VALUE
<b>Demand Limit Type Select</b>	Config→USER	24	2 (4-20mA Control) Default = 0 (None)
<b>mA For 100% Demand Limit</b>	Config→USER	28	4.0 mA Default = 0.0 mA
<b>mA For 0% Demand Limit</b>	Config→USER	29	20.0 mA Default = 10.0 mA
<b>Current Limit Select</b>	Config→USER	30	Yes Default = No
<b>Current Limit at 100%</b>	Config→USER	31	Default = 2000.0 Amps

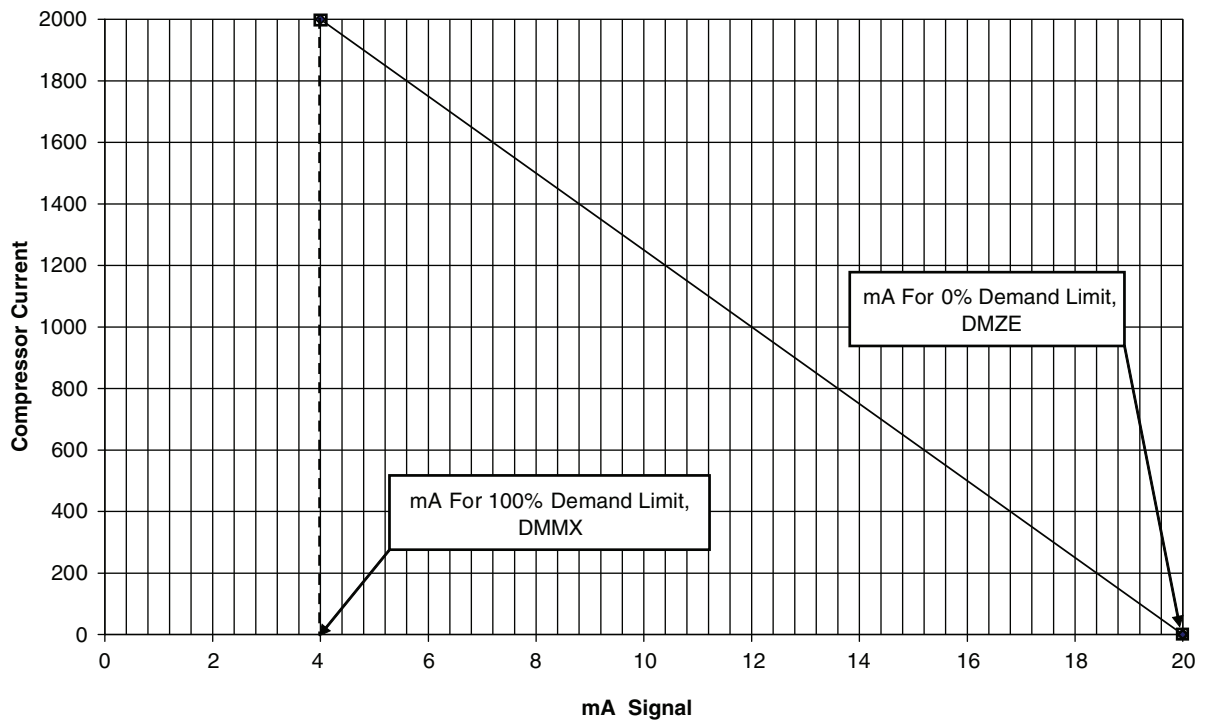
To configure this option with the Navigator display:

ITEM	ITEM EXPANSION	PATH	VALUE
<b>DMDC</b>	Demand Limit Select	Config→RSET	4-20MA INPUT Default = NONE
<b>DMMX</b>	mA for 100% Demand Lim	Config→RSET	4.0 mA Default = 0.0 mA
<b>DMZE</b>	mA for 0% Demand Limit	Config→RSET	20.0 mA Default = 10.0 mA
<b>CUR.S</b>	Current Limit Select	Config→OPTN	YES Default: NO
<b>CUR.F</b>	Current Limit at 100%	Config→OPTN	Default = 2000

In the following example, a 4 mA signal is Demand Limit for compressor current is 2000 amps and a 20 mA Demand Limit signal corresponds with a compressor current of 0 amps. The 4 to 20 mA signal is connected to TB6-1 and TB6-2. The demand limit is a linear interpolation between the two values entered. If the machine receives a 12 mA signal, the machine controls will limit the total compressor current capacity to 1000 amps. See Fig. 29.



**Fig. 28 — 4 to 20 mA Demand Limit (Capacity)**



**Fig. 29 — 4 to 20 mA Demand Limit (Compressor Current)**



**CCN LOADSHED CONTROLLED DEMAND LIMIT** — To configure Demand Limit for CCN Loadshed control, the unit Operating Type Control must be in CCN control. With the Touch Pilot™ display, the machine must be started with CCN Control. For the Navigator™ display, the Operating Control Type (**I/O Button, OPER**) must be CCN CONTROL.

The unit must be controlled by a Chillervisor module. The Chillervisor module can force the demand limit variable and directly control the capacity of the machine. Additionally, the unit's set point will be artificially lowered to force the chiller to load to the demand limit value.

**Ice Storage Operation** — Chiller operation can be configured to make and store ice. The Energy Management Module and an Ice Done Switch are required for operation in the Ice Mode. In this configuration, the machine can operate with up to three cooling set points: Cooling Set Point 1 (**Cooling Setpoint 1, CSP.1**) is used during the Occupied period; Cooling Set Point 2 (**Cooling Setpoint 2, CSP.2**) is used during the Unoccupied period when the ice build is complete (Ice Done Switch is closed); and Cooling Ice Set Point (**Cooling Ice Setpoint, CSP.3**) is used during the unoccupied period while ice is building (Ice Done Switch is open).

To configure this option with the Touch Pilot display:

DISPLAY NAME	PATH	LINE NO.	VALUE
Ice Mode Enable	Config→USER	42	Yes

To configure this option with the Navigator display:

ITEM	ITEM EXPANSION	PATH	VALUE
ICE.M	Ice Mode Enable	Configuration→OPTN	ENBL

**Broadcast Configuration** — The 30XA chiller is capable of broadcasting outside-air temperature (OAT), time, date, and holiday status to all elements in the CCN system. In the stand-alone mode, broadcast must be activated to utilize holiday schedules and adjust for daylight saving time. If the chiller is to be connected to a CCN system, determine which system element is to be the network broadcaster and activate broadcast in all other system elements. Broadcast is activated and deactivated in the BRODEFS Table. It is accessible from Touch Pilot display (**Config→BRODEFS**) or through Network Service Tool. It is not accessible through Navigator display.

Only one element should be configured as a broadcaster. If a broadcast is activated by a device that has been designated as a network broadcaster, then broadcasted time, date, and holiday status will be updated over the CCN system. If broadcast is enabled, a broadcast acknowledger must also be enabled. The acknowledger cannot be the same machine as the broadcasting machine.

**ACTIVATE** — The Activate variable enables the broadcast function of the *ComfortLink™* controls. If this variable is set to 0, this function is not used and holiday schedules and daylight savings compensation are not possible. Setting this variable to 1 allows the machine to broadcast and receive broadcasts on the network. The following information is broadcast: the time with compensation for daylight savings, date, holiday flag, and the outdoor-air temperature.

Set this variable to 2 for stand-alone units that are not connected to a CCN. With this configuration, daylight saving time and holiday determination will be done without broadcasting through the bus. This variable can only be changed when using the Touch Pilot display, *ComfortVIEW™* software, or Network Service Tool. This variable cannot be changed with the Navigator display.

To configure this option with the Touch Pilot display:

DISPLAY NAME	PATH	LINE NO.	VALUE
Activate	Config→BRODEFS	1	Range = 0 to 2 Default = 2

**OAT BROADCAST** — To enable the outside air temperature (OAT) broadcast, the unit broadcasting the temperature must be configured with its own CCN Bus and CCN Address. Leaving the parameters at the factory default of 0 for the CCN Bus and CCN Address disables the OAT Broadcast function. Once configured, the first broadcast of OAT will be within 5 minutes. This variable can only be changed when using the Touch Pilot display, *ComfortVIEW* software, or Network Service Tool. This variable cannot be changed with the Navigator display.

To configure this option with the Touch Pilot display:

DISPLAY NAME	PATH	LINE NO.	VALUE
Activate	Config→BRODEFS	1	Range = 0 to 2 Default = 2
OAT Broadcast	Config→BRODEFS	3	
Bus #	Config→BRODEFS	4	Range = 0 to 239 Default = 0
Element #	Config→BRODEFS	5	Range = 0 to 239 Default = 0

**BROADCAST ACKNOWLEDGER** — This configuration defines if the chiller will be used to acknowledge broadcast messages on the CCN bus. One broadcast acknowledger is required per bus, including secondary buses created by the use of a bridge. This variable can only be changed with the Touch Pilot display, *ComfortVIEW* software, or Network Service Tool. This variable cannot be changed with the Navigator display.

To configure this option with the Touch Pilot display:

DISPLAY NAME	PATH	LINE NO.	VALUE
Broadcast acknowledger	Config→Ctlt-ID	10	Yes

## Alarm Control

**ALARM ROUTING CONTROL** — Alarms recorded on the chiller can be routed through the CCN. To configure this option, the *ComfortLink* controls must be configured to determine which CCN elements will receive and process alarms. Input for the decision consists of eight digits, each of which can be set to either 0 or 1. Setting a digit to 1 specifies that alarms will be sent to the system element that corresponds to that digit. Setting all digits to 0 disables alarm processing. The factory default is 00000000. See Fig. 30. The default setting is based on the assumption that the unit will not be connected to a network. If the network does not contain a *ComfortVIEW*, *ComfortWORKS®*, *TeLink*, *DataLINK™*, or *BACLink* module, enabling this feature will only add unnecessary activity to the CCN Communication Bus.

This option can be modified by the Touch Pilot display. It cannot be modified with the Navigator display.

Typical configuration of the Alarm Routing variable is 11010000. This Alarm Routing status will transmit alarms to *ComfortView* software, *TeLink*, *BACLink*, and *DataLINK*.

To configure this option with the Touch Pilot display:

DISPLAY NAME	PATH	LINE NO.	VALUE
Alarm Routing Control	Config→ALARMDEF	1	Default = 00000000

DESCRIPTION	STATUS									POINT
Alarm Routing	0	0	0	0	0	0	0	0	0	ALRM_CNT
ComfortView™, or ComfortWorks®										
TeLink										
Unused										
BacLink or DataLink™										
Unused										

Fig. 30 — Alarm Routing Control

**ALARM EQUIPMENT PRIORITY** — The ComfortVIEW software uses the equipment priority value when sorting alarms by level. The purpose of the equipment priority value is to determine the order in which to sort alarms that have the same level. A priority of 0 is the highest and would appear first when sorted. A priority of 7 would appear last when sorted. For example, if two chillers send out identical alarms, the chiller with the higher priority would be listed first. The default is 4. This variable can only be changed when using the Touch Pilot display, ComfortVIEW software, or Network Service Tool. This variable cannot be changed with the Navigator™ display. To configure this option with the Touch Pilot™ display:

DISPLAY NAME	PATH	LINE NO.	VALUE
Alarm Equipment Priority	Config→ALARMDEF	2	Range = 0 to 7 Default = 4

**COMMUNICATION FAILURE RETRY TIME** — This variable specifies the amount of time that will be allowed to elapse between alarm retries. Retries occur when an alarm is not acknowledged by a network alarm acknowledge, which may use either ComfortVIEW software or TeLink. If acknowledgement is not received, the alarm will be re-transmitted after the number of minutes specified in this decision. This variable can only be changed with the Touch Pilot display, ComfortVIEW, or Network Service Tool. This variable cannot be changed with the Navigator display. To configure this option with the Touch Pilot display:

DISPLAY NAME	PATH	LINE NO.	VALUE
Comm Failure Retry Time	Config→ALARMDEF	3	Range = 1 to 240 minutes Default = 10 minutes

**RE-ALARM TIME** — This variable specifies the amount of time that will be allowed to elapse between re-alarms. A re-alarm occurs when the conditions that caused the initial alarm continue to persist for the number of minutes specified in this decision. Re-alarms will continue to occur at the specified interval until the condition causing the alarm is corrected. This variable can only be changed with the Touch Pilot display, ComfortVIEW, or Network Service Tool. This variable cannot be changed with the Navigator display. To configure this option with the Touch Pilot display:

DISPLAY NAME	PATH	LINE NO.	VALUE
Realarm Time	Config→ALARMDEF	4	Range = 1 to 254 minutes 255 = Re-Alarm Disabled Default = 30 minutes

**ALARM SYSTEM NAME** — This variable specifies the system element name that will appear in the alarms generated by the unit control. The name can be up to 8 alphanumeric

characters in length. This variable can only be changed when using the Touch Pilot display, ComfortVIEW, or Network Service Tool. This variable cannot be changed with the Navigator display.

To configure this option with the Touch Pilot display:

DISPLAY NAME	PATH	LINE NO.	VALUE
Alarm System Name	Config→ALARMDEF	5	Default = PRO_RGRW

**Daylight Saving Time Configuration** — The 30XA chiller control contains software which can automatically correct for daylight saving time. This software is accessible from the Touch Pilot display, ComfortVIEW, or Network Service Tool. It is not accessible through the Navigator display.

To enable this feature, Daylight Saving Select must be set to 1. The start of Daylight Saving must be configured by setting the Month, Day of Week, and Week of Month. The end for Daylight Saving must also be configured. To configure this option with the Touch Pilot display, see Table 36.

Table 36 — Daylight Savings Time Configuration

DISPLAY NAME	PATH	LINE NO.	VALUE
Activate	Config→BRODEFS	1	1 or 2 Default = 2
Daylight Saving Select	Config→BRODEFS	7	Enable Default = Dsble
Entering	Config→BRODEFS	8	
Month	Config→BRODEFS	9	Enter Starting Month for Daylight Saving
Day of Week (1=Monday)	Config→BRODEFS	10	Enter the Day of the Week Daylight Saving Starts
Week of Month	Config→BRODEFS	11	Enter Week of the Month Daylight Saving Starts
Leaving	Config→BRODEFS	12	
Month	Config→BRODEFS	13	Enter Ending Month for Daylight Saving
Day of Week (1=Monday)	Config→BRODEFS	14	Enter the Day of the Week Daylight Saving ends
Week of Month	Config→BRODEFS	15	Enter Week of the Month Daylight Saving ends

**Capacity Control Overrides** — The following capacity control overrides (**Active Capacity Override, CAPS**) will modify the normal operation routine. If any of the override conditions listed below are satisfied, the override will determine the capacity change instead of the normal control. Overrides are listed by priority order and are often linked to unit

operating modes. See Table 37 for a list of overrides. See the Operating Modes section on page 68 for more information regarding operating modes.

**Override #1: Cooler Freeze Protection** — This override attempts to avoid the freeze protection alarm. If the Leaving Water Temperature is less than Brine Freeze Set Point (**Brine Freeze Setpoint, LOSP**) + 2.0° F (1.1° C) then a stage of capacity is removed.

NOTE: The freeze set point is 34 F (1.1 C) for fresh water systems (**Cooler Fluid Type, FLUD=1**). The freeze set point is Brine Freeze Set Point (**Brine Freeze Setpoint, LOSP**), for Medium Temperature Brine systems (**Cooler Fluid Type, FLUD=2**).

**Override #2: Circuit A Low Saturated Suction Temperature in Cooling**

**Override #3: Circuit B Low Saturated Suction Temperature in Cooling**

**Override #4: Circuit C Low Saturated Suction Temperature in Cooling** — These overrides attempt to avoid the low suction temperature alarms and are active only when the compressor is running beyond the fully unloaded level. The slide valve in the affected circuit will be decreased in position if the Saturated Suction Temperature is less than Brine Freeze Set Point (**Brine Freeze Setpoint, LOSP**) -18.0 F (-10 C) for 90 seconds, or the Saturated Suction Temperature is less than -4 F (-20 C).

**Override #5: Low Temperature Cooling and High Temperature Heating** — This override decreases capacity when the difference between the Control Point (**Control Point, CTPT**) and the Leaving Water Temperature (**Cooler Leaving Fluid, LWT**) reaches a predetermined limit and the rate of change of the water is 0° F per minute or still decreasing.

**Override #6: Low Temperature Cooling and High Temperature Heating** — This override decreases capacity (approximately 5% of circuit capacity) when the Entering Water Temperature (**Cooler Entering Fluid, EWT**) is less than the Control Point (**Control Point, CTPT**).

**Override #7: Ramp Loading** — No capacity stage increase will be made if the unit is configured for ramp loading (**Ramp Loading Select, RLS=ENBL**) and the difference between the Leaving Water Temperature and the Control Point is greater than 4° F (2.2° C) and the rate of change of the leaving water is greater than Cool Ramp Loading Rate (**Cooling Ramp Loading, CRMP**). Operating mode 5 (MD05) will be in effect.

**Override #8: Service Manual Test Override** — This override mode places the unit into Service Test mode. The user can then use Service Test functions to test the unit. All safeties and higher priority overrides are monitored and acted upon.

**Override #9: Demand Limit** — This override mode is active when a command to limit the capacity is received. If the current unit capacity is greater than the active capacity limit value, a stage is removed. If the current capacity is lower than the capacity limit value, the control will not add a stage that will result in the new capacity being greater than the capacity limit value. Operating mode 4 (MD04) will be in effect.

**Override #10: Cooler Interlock Override** — This override prohibits compressor operation until the Cooler Interlock (**Cooler Flow Switch, LOCK**) is closed.

**Override #11: High Temperature Cooling and Low Temperature Heating** — This override algorithm runs once when the unit is switched to ON. If the difference between the Leaving Water Temperature (**Cooler Leaving Fluid, LWT**) and the Control Point (**Control Point, CTPT**) exceeds a calculated value and the rate of change of the water temperature is greater than -0.1° F/min, a stage will be added.

**Table 37 — Capacity Control Overrides**

CAPACITY CONTROL OVERRIDES	
1	Cooler Freeze Protection
2	Circuit A Low Saturated Suction Temperature in Cooling
3	Circuit B Low Saturated Suction Temperature in Cooling
4	Circuit C Low Saturated Suction Temperature in Cooling
5	Low Temperature Cooling and High Temperature Heating (LWT)
6	Low Temperature Cooling and High Temperature Heating (EWT)
7	Ramp Loading
8	Service Manual Test Override
9	Demand Limit
10	Cooler Interlock Override
11	High Temperature Cooling and Low Temperature Heating
12	High Temperature Cooling and Low Temperature Heating (minimum load control in effect)
13	Minimum On/Off and Off/On Time Delay
14	Slow Change Override
15	System Manager Capacity Control
16	Circuit A High Pressure Override
17	Circuit B High Pressure Override
18	Circuit C High Pressure Override
19	Standby Mode
20	—
21	—
22	Minimum On Time Delay
23	Circuit A Low Saturated Suction Temperature in Cooling
24	Circuit B Low Saturated Suction Temperature in Cooling
25	Circuit C Low Saturated Suction Temperature in Cooling
26	Circuit A High Discharge Gas Override
27	Circuit B High Discharge Gas Override
28	Circuit C High Discharge Gas Override
29	—
30	—
31	—
32	—
33	—
34	Circuit A Low Refrigerant Charge
35	Circuit B Low Refrigerant Charge
36	Circuit C Low Refrigerant Charge
37	—
38	—
39	—
40	—
41	Circuit A High Current Override
42	Circuit B High Current Override
43	Circuit C High Current Override
44	Circuit A High Suction Superheat at Part Load
45	Circuit B High Suction Superheat at Part Load
46	Circuit C High Suction Superheat at Part Load
47	—
48	—
49	—
50	Circuit A MCHX MOP Control
51	Circuit B MCHX MOP Control
52	Circuit C MCHX MOP Control
53	Circuit A Delay for Unloading the Slide Valve
54	Circuit B Delay for Unloading the Slide Valve
55	Circuit C Delay for Unloading the Slide Valve
56	Circuit A Delay for Refrigeration Isolation Valve to Open
57	Circuit B Delay for Refrigeration Isolation Valve to Open
58	Circuit C Delay for Refrigeration Isolation Valve to Open
59	Circuit A Low Oil Level
60	Circuit B Low Oil Level
61	Circuit C Low Oil Level
62	Circuit A High Motor Temperature Override
63	Circuit B High Motor Temperature Override
64	Circuit C High Motor Temperature Override
77	Boostload Function

Override #12: High Temperature Cooling and Low Temperature Heating — This override runs only when Minimum Load Control is Enabled, (**Hot Gas Bypass Select, HGBP**) and is set to 1, 2 or 3. This override will add a stage of capacity if the next stage is Minimum Load Control, when the difference between the Leaving Water Temperature (**Cooler Leaving Fluid, LWT**) and the Control Point (**Control Point, CPT**) exceeds a calculated value and the rate of change of the water temperature is greater than a fixed value.

Override #13: Minimum On/Off and Off/On Time Delay — Whenever a capacity change has been made, the control will remain at this capacity stage for the next 90 seconds. During this time, no capacity control algorithm calculations will be made. If the capacity step is a compressor, an additional 90-second delay is added to the previous hold time (see Override #22). This override allows the system to stabilize before another capacity stage is added or removed. If a condition of a higher priority override occurs, the higher priority override will take precedence. Operating Mode 10 (MD10) will be in effect.

Override #14: Slow Change Override — This override prevents compressor stage changes when the leaving temperature is close to the control point and slowly moving towards it.

Override #15: System Manager Capacity Control — If a Chillervisor module is controlling the unit and multiple chillers, the unit will increase capacity to attempt to load to the demand limited value.

Override #16: Circuit A High Pressure Override

Override #17: Circuit B High Pressure Override

Override #18: Circuit C High Pressure Override — This override attempts to avoid a high pressure failure. The algorithm is run every 4 seconds. If the Saturated Condensing Temperature for the circuit is above the High Pressure Threshold (**High Pressure Threshold, HP.TH**) then the position of slide valve will be unloaded.

Override #19: Standby Mode — This override algorithm will not allow a compressor to run if the unit is in Standby mode, (**Heat/Cool Status, HC.ST=2**).

Override #22: Minimum On Time Delay — In addition to Override #13 Minimum On/Off and Off/On Time Delay, for compressor capacity changes, an *additional* 90-second delay will be added to Override #13 delay. No compressor will be deenergized until 3 minutes have elapsed since the last compressor has been turned ON. When this override is active, the capacity control algorithm calculations will be performed, but no capacity reduction will be made until the timer has expired. A control with higher precedence will override the Minimum On Time Delay.

Override #23: Circuit A Low Saturated Suction Temperature in Cooling

Override #24: Circuit B Low Saturated Suction Temperature in Cooling

Override #25: Circuit C Low Saturated Suction Temperature in Cooling — If the circuit is operating close to the operational limit of the compressor, the circuit capacity will remain at the same point or unload to raise the saturated suction temperature. This algorithm will be active if the circuit is on and one of the following conditions is true:

1. Saturated Suction Temperature is less than the Brine Freeze Setpoint (**Brine Freeze Setpoint, LOSP**)  $-6^{\circ}\text{F}$  ( $3.3^{\circ}\text{C}$ ).
2. Saturated Suction Temperature is less than the Brine Freeze Setpoint (**Brine Freeze Setpoint, LOSP**) and the circuit approach (Leaving Water Temperature – Saturated Suction Temperature) is greater than  $15^{\circ}\text{F}$  ( $8.3^{\circ}\text{C}$ ) and the Circuit Superheat (Discharge Gas Temperature – Saturated Discharge Temperature) is greater than  $25^{\circ}\text{F}$  ( $13.9^{\circ}\text{C}$ ).

NOTE: The freeze set point is  $34^{\circ}\text{F}$  ( $1.1^{\circ}\text{C}$ ) for fresh water systems (**Cooler Fluid Type, FLUD=1**). The

freeze set point is Brine Freeze Set Point (**Brine Freeze Setpoint, LOSP**), for Medium Temperature Brine systems (**Cooler Fluid Type, FLUD=2**).

If any of these conditions are met, the appropriate operating mode, 21 (Circuit A), 22 (Circuit B) or 23 (Circuit C) will be in effect.

Override #26: Circuit A High Discharge Gas Override

Override #27: Circuit B High Discharge Gas Override

Override #28: Circuit C High Discharge Gas Override — When the temperature is above the limit curve minus  $2^{\circ}\text{F}$  ( $1.1^{\circ}\text{C}$ ) increase in capacity will not be allowed. This override will remain active until the discharge gas temperature drops below the limit curve by  $-3^{\circ}\text{F}$  ( $-1.7^{\circ}\text{C}$ ).

Override #34: Circuit A Low Refrigerant Charge

Override #35: Circuit B Low Refrigerant Charge

Override #36: Circuit C Low Refrigerant Charge — The capacity override attempts to protect the compressor from starting with no refrigerant in the circuit. This algorithm runs only when the circuit is not operational (compressor is OFF). There are several criteria that will enable this override:

1. The saturated suction temperature or saturated discharge temperature is less than  $-13^{\circ}\text{F}$  ( $-10.6^{\circ}\text{C}$ ).
2. All of these conditions must be true:
  - a. The saturated suction temperature or saturated discharge temperature is less than leaving water temperature by more than  $5.4^{\circ}\text{F}$  ( $3.0^{\circ}\text{C}$ ).
  - b. Saturated suction temperature or saturated discharge temperature is less than  $41^{\circ}\text{F}$  ( $5^{\circ}\text{C}$ ).
  - c. Outdoor air temperature is less than  $32^{\circ}\text{F}$  ( $0^{\circ}\text{C}$ ).
  - d. Saturated suction temperature or saturated discharge temperature is less than the outdoor air temperature by more than  $5.4^{\circ}\text{F}$  ( $3.0^{\circ}\text{C}$ ).
3. All of these conditions must be true:
  - a. The saturated suction temperature or saturated discharge temperature is less than leaving water temperature by more than  $5.4^{\circ}\text{F}$  ( $3.0^{\circ}\text{C}$ ).
  - b. Saturated suction temperature or saturated discharge temperature is less than  $41^{\circ}\text{F}$  ( $5^{\circ}\text{C}$ ).
  - c. Saturated suction temperature or saturated discharge temperature is less than the brine freeze point (**Brine Freeze Setpoint, LOSP**) by more than  $6^{\circ}\text{F}$  ( $3.3^{\circ}\text{C}$ ).

NOTE: The freeze set point is  $34^{\circ}\text{F}$  ( $1.1^{\circ}\text{C}$ ) for fresh water systems (**Brine Freeze Setpoint, FLUD=1**). The freeze set point is brine freeze set point (**Brine Freeze Setpoint, LOSP**), for medium temperature brine systems (**Cooler Fluid Type, FLUD=2**).

4. All of these conditions must be true:
  - a. The saturated suction temperature or saturated discharge temperature is less than leaving water temperature by more than  $5.4^{\circ}\text{F}$  ( $3.0^{\circ}\text{C}$ ).
  - b. Saturated suction temperature or saturated discharge temperature is less than  $41^{\circ}\text{F}$  ( $5^{\circ}\text{C}$ ).
  - c. Saturated suction temperature or saturated discharge temperature is less than the outdoor-air temperature by more than  $9^{\circ}\text{F}$  ( $5^{\circ}\text{C}$ ).

If any of these conditions 1, 2, 3 or 4 are met, the appropriate operating mode, 21 (Circuit A), 22 (Circuit B) or 23 (Circuit C) will be in effect.

Override #41: Circuit A High Current Override

Override #42: Circuit B High Current Override

Override #43: Circuit C High Current Override — This override attempts to avoid an overcurrent failure. The algorithm is run every 4 seconds. If the compressor current is greater than 79% of must trip amps (MTA) but less than 85% MTA then the

capacity will be held at current capacity. If the compressor current is greater than 85% MTA then capacity will be reduced by repositioning the slide valve until the current is less than 85% MTA (**Must Trip Amps, MTA.X**).

Override #44: Circuit A High Suction Superheat at Part Load

Override #45: Circuit B High Suction Superheat at Part Load

Override #46: Circuit C High Suction Superheat at Part Load

— If the compressor of the circuit is on, the compressor current is no more than 30% of the MTA, main EXV is more than 90% open and the suction superheat is higher than the superheat control point for more than 5 minutes, then the circuit will be shut down.

Override #50: Circuit A MCHX MOP Control Override

Override #51: Circuit B MCHX MOP Control Override

Override #52: Circuit C MCHX MOP Control Override

— This override shall prevent the compressor from increasing capacity when saturated suction temperature is greater than the MOP setpoint and saturated condensing temperature is greater than the maximum condensing temperature setpoint minus 15 F on units equipped with MCHX condenser option. This is to avoid high pressure alarm and operation outside the compressor envelope.

Override #53: Circuit A Delay for Unloading the Slide Valve

Override #54: Circuit B Delay for Unloading the Slide Valve

Override #55: Circuit C Delay for Unloading the Slide Valve

— This override prevents the compressor from re-starting with locked rotor failure after being shutdown due to an alarm or power cycle. The delay varies depending on the size of the compressor. Refer to Table 38 for compressor nominal capacities. A delay of 20 minutes will elapse for 165 and 185 ton compressors, a delay of 8 minutes will elapse for 90 and 120 ton compressors, and 5 minutes will elapse for 45 and 50 ton compressors. The delay allows the slide valve of the compressor to move back to its fully unloaded position. The delay is adjusted according to the percent of the compressor running capacity before it is shut down. If the compressor is stopped normally, no delay will be applied. If the compressor is shut down by the locked rotor alarm, a full delay will be applied before the compressor is allowed to re-start. See Table 38 for compressor nominal capacity.

Override #56: Circuit A Delay for Refrigeration Isolation Valve to Open

Override #57: Circuit B Delay for Refrigeration Isolation Valve to Open

Override #58: Circuit C Delay for Refrigeration Isolation Valve to Open

— This override allows the discharge motorized ball valve to open before the compressor starts. The delay is 2 minutes and 30 seconds. (Does not apply to units with DX cooler option.)

Override #59: Circuit A Low Oil Level

Override #60: Circuit B Low Oil Level

Override #61: Circuit C Low Oil Level — This override is only effective when the circuit is not running. The override will prevent the circuit from starting up with a low oil level. If this override occurs three times, the low oil level alarm will be tripped.

Override #62: Circuit A High Motor Temperature Override

Override #63: Circuit B High Motor Temperature Override

Override #64: Circuit C High Motor Temperature Override

— This override prevents the compressor motor temperature from rising above the high temperature limit, but still allows the chiller to run close to the high temperature limit by unloading the compressor. If the motor temperature is greater than 214 F (101.1 C), the compressor will not load. This override will remain active until the temperature drops below 214 F (101.1 C). If the motor temperature is greater than 225 F (107.2 C) for 60 seconds, the circuit capacity will decrease by one stage. If the motor temperature is greater than 228 F (108.9), the circuit capacity will decrease by one stage immediately.

Override #77: Boostload Function — This override can be present when boostload function is enabled. It is set in the following conditions :

if cool\_lwt > ctrl\_pnt + 5.4 and cool\_ewt > ctrl\_pnt + 9.0 and demand limit > 99%.

**Head Pressure Control** — The Main Base Board (MBB) controls the condenser fans to maintain the lowest condensing temperature possible, and thus, the highest unit efficiency. The MBB uses the saturated condensing temperature input from the discharge pressure transducer to control the fans. Head pressure control is maintained through a calculated set point which is automatically adjusted based on actual saturated condensing and saturated suction temperatures so that the compressor(s) is (are) always operating within the manufacturer's specified envelope (see Fig. 31). Each time a fan is added, the calculated head pressure set point will be raised 25° F (13.9° C) for 35 seconds to allow the system to stabilize. The control will automatically reduce the unit capacity as the saturated condensing temperature approaches an upper limit. See capacity overrides #16-18. The control will indicate through an operating mode that high ambient unloading is in effect. If the saturated condensing temperature in a circuit exceeds the calculated maximum, the circuit will be stopped. For these reasons, there are no head pressure control methods or set points to enter. The control will turn off a fan stage when the condensing temperature is below the minimum head pressure requirement for the compressor. Fan sequences are shown in Fig. 31. See Table 38 for compressor nominal capacity.

**LOW AMBIENT TEMPERATURE HEAD PRESSURE CONTROL OPTION** — Units will start and operate down to 32 F (0° C) as standard. Operation to -20 F (-29 C) requires optional low ambient head pressure control as well as wind baffles (field fabricated and installed on all units for operation below 32 F [0° C]) if wind velocity is anticipated to be greater than 5 mph (8 kp/h). Inhibited propylene glycol or other suitable corrosion-resistant anti-freeze solution must be field supplied and installed in all units for unit operation below 34 F (1.1 C). Solution must be added to fluid loop to protect loop down to 15° F (8.3° C) below minimum operating ambient temperature. Concentration should be based on expected minimum temperature and either "Burst" or "Freeze" protection levels. At least 6 gal per ton (6.5 l/kW) of water volume is the recommended minimum for a moderate system load.

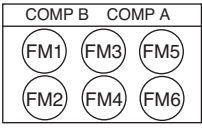
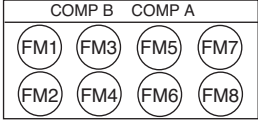
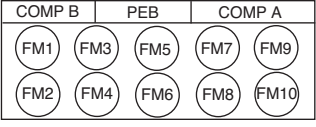
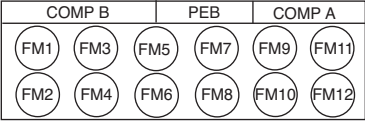
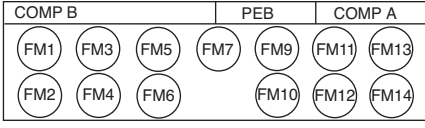
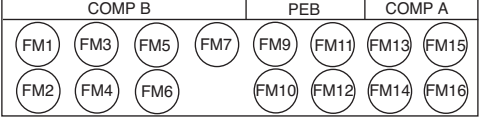
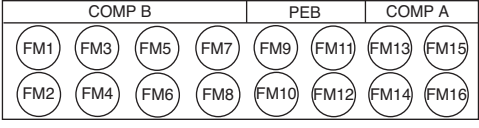
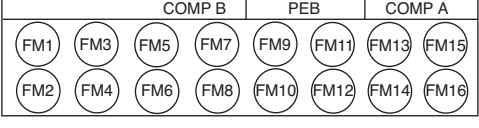
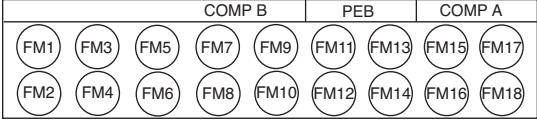
For low-ambient temperature operation, the lead fan on a circuit can be equipped with low ambient temperature head pressure control option or accessory. The controller adjusts fan speed to maintain the calculated head pressure set point.

**LOW AMBIENT TEMPERATURE HEAD PRESSURE CONTROL OPERATING INSTRUCTIONS** — The 30XA low ambient control is a variable speed drive (VFD) that varies the speed of the lead condenser fan in each circuit to maintain the calculated head pressure control set point. The fan speed varies in proportion to the 0 to 10 vdc analog signal produced by the AUX1 fan board. The display indicates motor speed in Hz by default.

**Table 38 — 30XA Compressor Nominal Capacity**

30XA UNIT SIZE	080, 082	090, 092	100, 102	110, 112	120, 122	140, 142	160, 162	180, 182	200, 202	220, 222
<b>Compressor Nominal Capacity (tons)</b>										
<b>Circuit A</b>	45	45	50	60	60	90	100	90	100	120
<b>Circuit B</b>	45	45	50	50	60	50	60	90	100	100
<b>Circuit C</b>	—	—	—	—	—	—	—	—	—	—
30XA UNIT SIZE	240, 242	260, 262	280, 282	300, 302	325, 327	350, 352	400	450	500	
<b>Compressor Nominal Capacity (tons)</b>										
<b>Circuit A</b>	120	165	165	185	165	185	120	185	185	
<b>Circuit B</b>	120	100	120	120	165	165	120	90	120	
<b>Circuit C</b>	—	—	—	—	—	—	165	185	185	

## CIRCUIT STAGE

		CIRCUIT										
 <p>30XA080,082</p>	<b>A</b>	Fan stage A	1	2	3							
		Contactor #	FC A1	FC A2	FC A3							
		Fan position	FM5	FM3	FM6							
<b>B</b>	Fan stage B	1	2	3								
	Contactor #	FC B1	FC B2	FC B3								
	Fan position	FM1	FM4	FM2								
 <p>30XA090-122</p>	<b>A</b>	Fan stage A	1	2	3	4						
		Contactor #	FC A1	FC A2	FC A3	FC A4						
		Fan position	FM7	FM5	FM8	FM6						
<b>B</b>	Fan stage B	1	2	3	4							
	Contactor #	FC B1	FC B2	FC B3	FC B4							
	Fan position	FM1	FM3	FM2	FM4							
 <p>30XA140-162</p>	<b>A</b>	Fan stage A	1	2	3	4	5	6				
		Contactor #	FC A1	FC A2	FC A3	FC A4	FC A5	FC A6				
		Fan position	FM9	FM7	FM5	FM10	FM8	FM6				
<b>B</b>	Fan stage B	1	2	3	4							
	Contactor #	FC B1	FC B2	FC B3	FC B4							
	Fan position	FM1	FM3	FM2	FM4							
 <p>30XA180-202</p>	<b>A</b>	Fan stage A	1	2	3	4	5	6				
		Contactor #	FC A1	FC A2	FC A3	FC A4	FC A5	FC A6				
		Fan position	FM11	FM9	FM7	FM12	FM10	FM8				
<b>B</b>	Fan stage B	1	2	3	4	5	6					
	Contactor #	FC B1	FC B2	FC B3	FC B4	FC B5	FC B6					
	Fan position	FM1	FM3	FM5	FM2	FM4	FM6					
 <p>30XA220-242</p>	<b>A</b>	Fan stage A	1	2	3	4	5	6	7			
		Contactor #	FC A1	FC A2	FC A3	FC A4	FC A5	FC A6	FC A7			
		Fan position	FM13	FM11	FM9	FM7	FM14	FM12	FM10			
<b>B</b>	Fan stage B	1	2	3	4	5	6					
	Contactor #	FC B1	FC B2	FC B3	FC B4	FC B5	FC B6					
	Fan position	FM1	FM3	FM5	FM2	FM4	FM6					
 <p>30XA260,262</p>	<b>A</b>	Fan stage A	1	2	3	4	5	6	7	8		
		Contactor #	FC A1	FC A2	FC A3	FC A4	FC A5	FC A6	FC A7	FC A8	FC A9	
		Fan position	FM15	FM13	FM11	FM9	FM7	FM16	FM14	FM12	FM10	
<b>B</b>	Fan stage B	1	2	3	4	5	6					
	Contactor #	FC B1	FC B2	FC B3	FC B4	FC B5	FC B6					
	Fan position	FM1	FM3	FM5	FM2	FM4	FM6					
 <p>30XA280,282</p>	<b>A</b>	Fan stage A	1	2	3	4	5	6	7	8		
		Contactor #	FC A1	FC A2	FC A3	FC A4	FC A5	FC A6	FC A7	FC A8	FC A9	
		Fan position	FM15	FM13	FM11	FM9	FM7	FM16	FM14	FM12	FM10	
<b>B</b>	Fan stage B	1	2	3	4	5	6	7				
	Contactor #	FC B1	FC B2	FC B3	FC B4	FC B5	FC B6	FC B7				
	Fan position	FM1	FM3	FM5	FM8	FM2	FM4	FM6				
 <p>30XA300,302</p>	<b>A</b>	Fan stage A	1	2	3	4	5	6	7	8		
		Contactor #	FC A1	FC A2	FC A3	FC A4	FC A5	FC A6	FC A7	FC A8	FC A9	FC A10
		Fan position	FM15	FM13	FM11	FM9	FM7	FM16	FM14	FM12	FM10	FM8
<b>B</b>	Fan stage B	1	2	3	4	5	6					
	Contactor #	FC B1	FC B2	FC B3	FC B4	FC B5	FC B6					
	Fan position	FM1	FM3	FM5	FM2	FM4	FM6					
 <p>30XA325-352</p>	<b>A</b>	Fan stage A	1	2	3	4	5	6	7	8		
		Contactor #	FC A1	FC A2	FC A3	FC A4	FC A5	FC A6	FC A7	FC A8	FC A9	
		Fan position	FM17	FM15	FM13	FM11	FM9	FM18	FM16	FM14	FM12	
<b>B</b>	Fan stage B	1	2	3	4	5	6	7	8			
	Contactor #	FC B1	FC B2	FC B3	FC B4	FC B5	FC B6	FC B7	FC B8	FC B9		
	Fan position	FM1	FM3	FM5	FM7	FM10	FM2	FM4	FM6	FM8		

**LEGEND**

**COMP** — Compressor      **FM** — Fan Motor  
**FC** — Fan Contactor      **PEB** — Power Electrical Box

**Fig. 31 — Fan Staging**



CIRCUIT STAGE

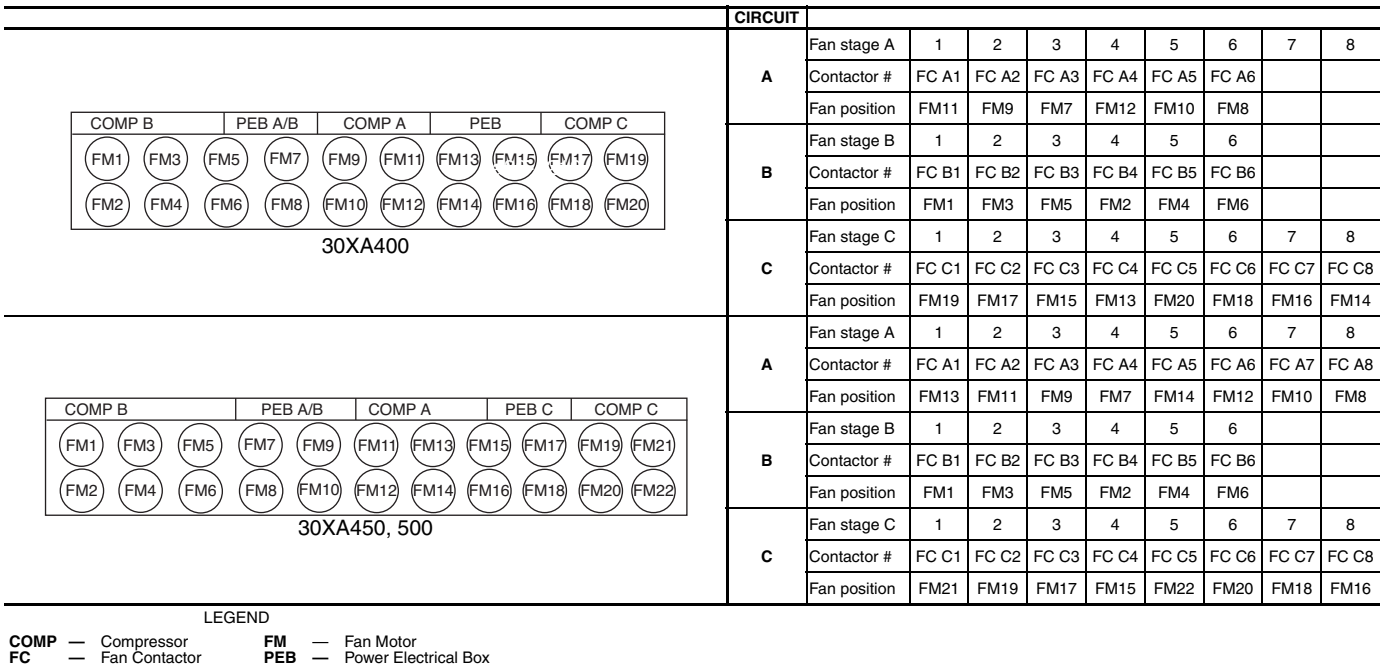


Fig. 31 — Fan Staging (cont)

**Operation** — The low ambient temperature head pressure controller is pre-configured to operate from a 0 to 10 vdc analog input signal present on terminals 3 (AIN+) and 4 (AIN-). Jumpers between terminals 2 and 4 and terminals 5 and 8 (5 and 9 for 575-v drives) are required for proper operation. The drive is enabled based on an increase in the analog input signal above 0 vdc. Output is varied from 0 Hz to 60 Hz as the analog signal increases from 0 vdc to 10 vdc. When the signal is at 0 vdc the drive holds the fan at 0 rpm. The head pressure control set point is not adjustable. The MBB determines the control set point as required.

**Replacement** — If the controller is replaced the parameters in Table 39 must be configured. See Fig. 32 and 33.

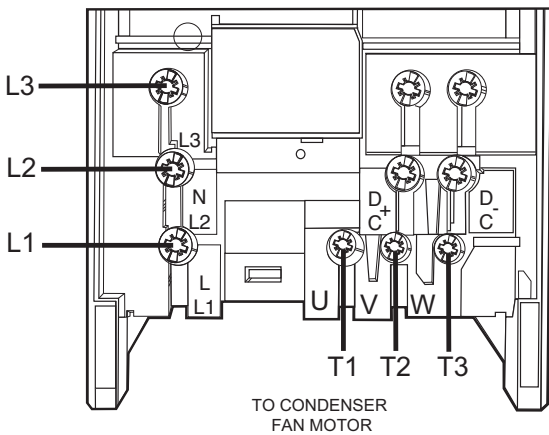
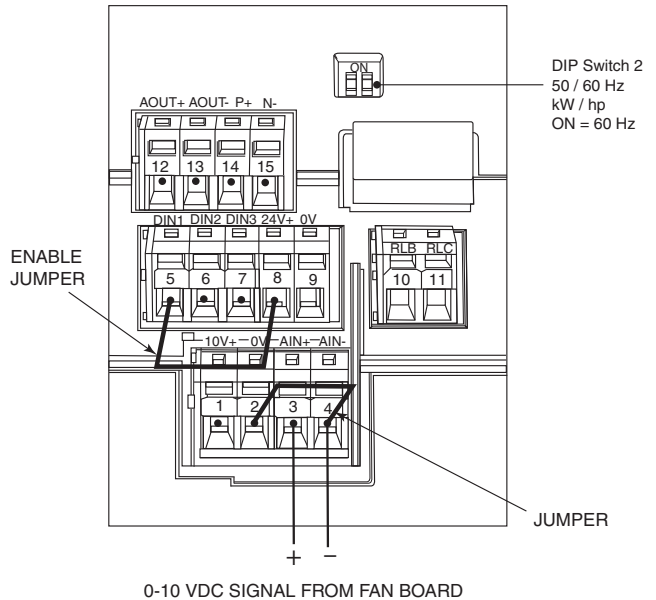


Fig. 32 — Siemens Low Ambient Temperature Control Power Wiring



0-10 VDC SIGNAL FROM FAN BOARD  
 Fig. 33 — Siemens Low Ambient Temperature Control Signal Wiring

**Table 39 — Siemens VFD Control Parameters**

PARAMETER*	VALUE	DESCRIPTION
P0010	1	Enter Quick Commissioning
P0311	1140†	Rated Motor Speed
	850**	
P0757	0.50	Control Signal Scaling Offset
P0761	0.50	Control Signal Scaling Offset
P3900	1	End of Quick Commissioning
P0003	3	User Access Level
P1210	6	Automatic Restart
P1310	10%	Continuous Boost

\*Remove jumper from terminals 5 and 8 (or terminals 5 and 9 for 575 v) before configuring parameter. Reinstall jumper after configuration is complete.

†High Ambient option.

\*\*Standard.

The DIP switches must also be set. DIP switch 1 is not used and DIP switch 2 is the motor frequency. (OFF = 50 Hz, ON = 60 Hz)

**Drive Programming** — Parameter values can be altered via the operator panel. The operator panel features a five-digit, seven-segment display for displaying parameter numbers and values, alarm and fault messages, set points, and actual values. See Fig. 34 and 35. See Table 40 for additional information on the operator panel.

NOTE: The operator panel motor control functions are disabled by default. To control the motor via the operator panel, parameter P0700 should be set to 1 and P1000 set to 1. The operator panel can be fitted to and removed from the drive while power is applied. If the operator panel has been set as the I/O control (P0700 = 1), the drive will stop if the operator panel is removed.

**Changing Parameters with the Operator Panel** — See Fig. 35 for the procedure for changing the value of parameter P0004. Modifying the value of an indexed parameter is illustrated in Fig. 35 using the example of P0719. Follow the same procedure to alter other parameters using the operator panel.

NOTE: In some cases when changing parameter values the display on the operator panel displays **P-----**. This means the drive is busy with tasks of higher priority.



**Fig. 34 — Siemens Low Ambient Temperature Controller**

**CHANGING P0004 — PARAMETER FILTER FUNCTION**

STEP	RESULT ON DISPLAY
1 Press <b>P</b> to access parameters	r0000
2 Press <b>▲</b> until P0004 is displayed	P0004
3 Press <b>P</b> to access the parameter value level	0
4 Press <b>▲</b> or <b>▼</b> to the required value	7
5 Press <b>P</b> to confirm and store the value	P0004
6 Only the command parameters are visible to the user.	

**CHANGING P0719 AN INDEXED PARAMETER SELECTION OF COMMAND/SETPOINT SOURCE**

STEP	RESULT ON DISPLAY
1 Press <b>P</b> to access parameters	r0000
2 Press <b>▲</b> until P0719 is displayed	P0719
3 Press <b>P</b> to access the parameter value level	rn000
4 Press <b>P</b> to display current set value	0
5 Press <b>▲</b> or <b>▼</b> to the required value	12
6 Press <b>P</b> to conform and store the value	P0719
7 Press <b>▼</b> until r0000 is displayed	r0000
8 Press <b>P</b> to return the display to the standard drive display (as defined by the customer)	

**Fig. 35 — Changing Parameters with the Operator Panel**

**Changing Single Digits in Parameter Values** — For changing the parameters value rapidly, the single digits of the display can be changed by performing the following actions:

Ensure the operator panel is in the parameter value changing level as described in the Changing Parameters with the Operator Panel section.

1. Press **Fn** (function button), which causes the farthest right digit to blink.
2. Change the value of this digit by pressing **▲** or **▼**.
3. Pressing **Fn** (function button) again to cause the next digit to blink.
4. Perform steps 2 to 4 until the required value is displayed.
5. Press **P** (parameter button) to exit the parameter value changing level.

NOTE: The function button may also be used to acknowledge a fault condition.

**Quick Commissioning (P0010=1)** — It is **important** that parameter P0010 is used for commissioning and P0003 is used to select the number of parameters to be accessed. The P0010 parameter allows a group of parameters to be selected that will enable quick commissioning. Parameters such as motor settings and ramp settings are included. At the end of the quick commissioning sequences, P3900 should be selected, which, when set to 1, will carry out the necessary motor calculations and clear all other parameters (not included in P0010=1) to the default settings. This will only occur in Quick Commissioning mode. See Fig. 36.

**Reset to Factory Default** — To reset all parameters to the factory default settings, the following parameters should be set as follows:

1. Jumpers must be in place from terminals 2 and 4 and 5 and 8 (5 and 9 for 575v drives only).
2. Remove the keypad (pull out from top) and verify that DIP switch 1 is OFF and 2 is ON. Replace keypad.
3. Power up the drive. Press Parameter **P** key. Press **▲** to Parameter **P0010**.
4. Press **P**, then **▲** to change the 0 to a 1. Press **P** again to accept the change.
5. Press **▲** to Parameter **P0311**. Press **P** and press **▼** to change this value to 1140 for 6-pole motors or 850 for units with 8-pole motors. Press **P** to accept.
6. Press **▲** to Parameter **P3900**. Press **P** and use **▲** to change this value to 1. Press **P** to accept.
7. The drive will finish standard programming. Remove one end of the jumper wire from terminal 8.
8. Press **P** again and go to Parameter **P0003**. Press **P** and use **▲** to change this value to 3. Press **P** to accept.
9. Press **▲** to Parameter **P1210**. Press **P** and use **▲** to change this value to 6. Press **P** to accept.
10. Press **▲** to Parameter **P1310**. Press **P** and use **▼** to change this value to 10%. Press **P** to accept.
11. Press the Function **Fn** key and then **P**. The display will read 0.00 Hz.
12. Replace the wire jumper in terminal 8.

13. The drive is now active. Check fan rotation prior to testing. If the fan is spinning forward, further adjustment is needed. Fan should sit still when commanded speed is 0%. If the fan is spinning forward slightly, press **P** and **▲** to Parameter **P0761**. Press **P** and use **▲** to change this value to 0.1. Press **P** to accept. Check the fan. If rotation has stopped no further adjustment is required. If the fan is still rotating forward, press **P** and use **▲** to change this value to 0.2. Press **P** to accept. Repeat as needed until the fan is holding still or is just barely moving in either direction. Do NOT enter a value greater than 0.5 for this parameter without first contacting your Carrier representative.

**Troubleshooting with the Operating Panel** — Warnings and faults are displayed on the operating panel with Axxx and Fxxx. The individual messages are shown in Table 41.

If the motor fails to start, check the following:

- Power is present on T1, T2 and T3.
- Configuration jumpers are in place.
- Control signal between 1 vdc and 10 vdc is present on terminals 3 and 4.
- P0010 = 0.
- P0700 = 2.

**Fault Messages (Tables 41 and 42)** — In the event of a failure, the drive switches off and a fault code appears on the display.

NOTE: To reset the fault code, one of the following methods can be used:










1. Cycle the power to the drive.
2. Press the **Fn** button on the operator panel.

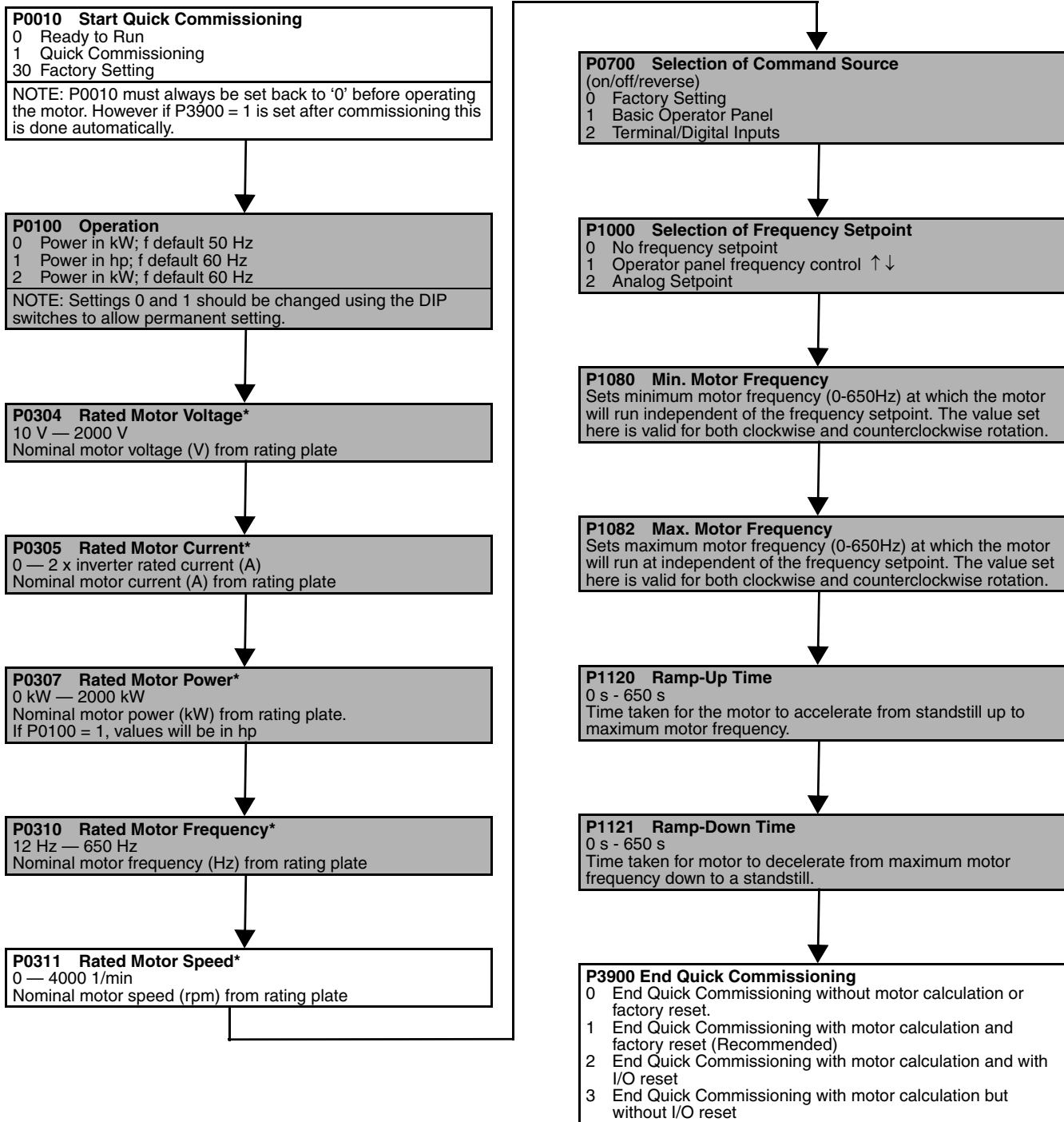
**Schneider Altivar VFD Operation** — The low ambient temperature head pressure controller is pre-configured to operate from a 0 to 10 vdc analog input signal present on terminals AI1 and COM. A jumper between terminals 24V and LI1 is required for proper operation. The drive is enabled based on an increase in the analog input signal above 0 vdc. Output is varied from 0 Hz to 60 Hz as the analog signal increases from 0 vdc to 10 vdc. When the signal is at 0 vdc the drive holds the fan at 0 rpm. The head pressure control set point is not adjustable. The MBB determines the control set point as required. The operating panel is shown in Fig. 37. Refer to the Quick Start Guide for how to access the programming mode, or the documentation on CD-ROM (shipped with each VFD) for a complete set of VFD parameters, fault codes and troubleshooting information.

**Schneider Altivar VFD Replacement** — For Altivar 21 VFDs, if the controller is replaced the parameters in Table 43 must be configured. It is recommended that the configuration of the VFD is verified per Table 43 prior to proceeding. Also, the following must be wired:

1. A jumper must be in place from terminal P24 to F.
2. Connect the red and black wires from fan board 0-10 VDC output to terminal VIA and CC respectively.
3. Connect the motor power wires T1, T2 and T3 respectively to terminal U/T1, V/T2 and W/T3 of the drive.
4. Connect the line power wires L1, L2 and L3 from control box respectively to terminal R/L1, S/L2 and T/L3 of the drive.

**Table 40 — Siemens Low Ambient Temperature Controller Operator Panel**

PANEL/BUTTON	FUNCTION	DESCRIPTION
	Indicates Status	The LCD displays the settings currently used by the converter.
	Start Converter	The Start Converter button is disabled by default. To enable this button set P0700 = 1.
	Stop Converter	Press the Stop Converter button to cause the motor to come to a standstill at the selected ramp down rate. Disabled by default, to enable set P0700 = 1. Press the Stop Converter button twice (or hold) to cause the motor to coast to a standstill. This function is always enabled.
	Change Direction	Press the Change Direction button to change the direction of rotation of the motor. Reverse is indicated by a minus (-) sign or a flashing decimal point. Disabled by default, to enable set P0700 = 1.
	Jog Motor	Press the Jog Motor button while the inverter has no output to cause the motor to start and run at the preset jog frequency. The motor stops when the button is released. The Jog Motor button is not enabled when the motor is running.
	Functions	The Functions button can be used to view additional information. Press and hold the button to display the following information starting from any parameter during operation: <ol style="list-style-type: none"> <li>1. DC link voltage (indicated by d – units V).</li> <li>2. Output current. (A)</li> <li>3. Output frequency (Hz)</li> <li>4. Output voltage (indicated by o – units V).</li> <li>5. The value selected in P0005 (If P0005 is set to show any of the above [3, 4, or 5] then this will not be shown when toggling through the menu).</li> </ol> Press the Functions button repeatedly to toggle through displayed values. <b>Jump Function</b> Press of the Fn button from any parameter (rXXXX or PXXXX) to immediately jump to r0000, when another parameter can be changed, if required. Return to r0000 and press the Functions button again to return.
	Access Parameters	Allows access to the parameters.
	Increase Value	Press the Increase Value button to increase the displayed value. To change the Frequency Setpoint using the operator panel set P1000 = 1.
	Decrease Value	Press the Decrease Value button to decrease the displayed value. To change the Frequency Setpoint using the operating panel set P1000 = 1.



\*Motor-specific parameters — see motor rating plate.  
NOTE: Shaded boxes are for reference only.

**Fig. 36 — Siemens Low Ambient Temperature Controller Flow Chart Quick Commissioning**


**Table 41 — Siemens Low Ambient Temperature Controller Fault Messages**

FAULT	POSSIBLE CAUSES	TROUBLESHOOTING
<b>F0001 Overcurrent</b>	<ul style="list-style-type: none"> <li>• Motor power does not correspond to the inverter power</li> <li>• Motor lead short circuit</li> <li>• Ground fault</li> </ul>	Check the following: <ol style="list-style-type: none"> <li>1. Motor power (P0307) must correspond to inverter power (P0206)</li> <li>2. Motor cable and motor must have no short-circuits or ground faults</li> <li>3. Motor parameters must match the motor in use</li> <li>4. Motor must not be obstructed or overloaded</li> </ol> After Steps 1-4 have been checked, increase the ramp time (P1120) and reduce the boost level (P1310, P1311, P1312).
<b>F0002 Overvoltage</b>	<ul style="list-style-type: none"> <li>• DC-link voltage (r0026) exceeds trip level (P2172)</li> <li>• Overvoltage can be caused either by too high main supply voltage or if motor is in regenerative mode</li> <li>• Regenerative mode can be caused by fast ramp downs or if the motor is driven from an active load</li> </ul>	Check the following: <ol style="list-style-type: none"> <li>1. Supply voltage (P0210) must lie within limits indicated on rating plate</li> <li>2. DC-link voltage controller must be enabled (P1240) and have parameters set correctly</li> <li>3. Ramp-down time (P1121) must match inertia of load</li> </ol>
<b>F0003 Undervoltage</b>	<ul style="list-style-type: none"> <li>• Main supply failed</li> <li>• Shock load outside specified limits</li> </ul>	Check the following: <ol style="list-style-type: none"> <li>1. Supply voltage (P0210) must lie within limits indicated on rating plate</li> <li>2. Supply must not be susceptible to temporary failures or voltage reductions</li> </ol>
<b>F0004 Drive Overtemperature</b>	<ul style="list-style-type: none"> <li>• Ambient temperature outside of limits</li> <li>• Fan failure</li> </ul>	Check the following: <ol style="list-style-type: none"> <li>1. Fan must turn when inverter is running</li> <li>2. Pulse frequency must be set to default value</li> <li>3. Air inlet and outlet points are not obstructed</li> <li>4. Ambient temperature could be higher than specified for the drive.</li> </ol>
<b>F0005 Drive I<sup>2</sup>t</b>	<ul style="list-style-type: none"> <li>• Drive overloaded</li> <li>• Duty cycle too demanding</li> <li>• Motor power (P0307) exceeds drive power capability (P0206)</li> </ul>	Check the following: <ol style="list-style-type: none"> <li>1. Load duty cycle must lie within specified limits</li> <li>2. Motor power (P0307) must match drive power (P0206)</li> </ol>
<b>F0011 Motor Overtemperature I<sup>2</sup>t</b>	<ul style="list-style-type: none"> <li>• Motor overloaded</li> <li>• Motor data incorrect</li> <li>• Long time period operating at low speeds</li> </ul>	<ol style="list-style-type: none"> <li>1. Check motor data</li> <li>2. Check loading on motor</li> <li>3. Boost settings too high (P1310, P1311, P1312)</li> <li>4. Check parameter for motor thermal time constant</li> <li>5. Check parameter for motor I<sup>2</sup>t warning level</li> </ol>
<b>F0041 Stator Resistance Measurement Failure</b>	Stator resistance measurement failure	<ol style="list-style-type: none"> <li>1. Check if the motor is connected to the drive</li> <li>2. Check that the motor data has been entered correctly</li> </ol>
<b>F0051 Parameter EEPROM Fault</b>	Reading or writing of the non-volatile parameter storage has failed	<ol style="list-style-type: none"> <li>1. Factory reset and new parameters set</li> <li>2. Replace drive</li> </ol>
<b>F0052 Powerstack Fault</b>	Reading of the powerstack information has failed or the data is invalid	Replace drive
<b>F0060 Asic Timeout</b>	Internal communications failure	<ol style="list-style-type: none"> <li>1. Acknowledge fault</li> <li>2. Replace drive if repeated</li> </ol>
<b>F0070 Communications Board Set Point Error</b>	No setpoint received from communications board during telegram off time	<ol style="list-style-type: none"> <li>1. Check connections to the communications board</li> <li>2. Check the master</li> </ol>
<b>F0071 No Data for RS232 Link During Telegram Off Time</b>	No response during telegram off time via BOP link	<ol style="list-style-type: none"> <li>1. Check connections to the communications board</li> <li>2. Check the master</li> </ol>
<b>F0072 No Data from RS485 Link During Telegram Off Time</b>	No response during telegram off time via COM link	<ol style="list-style-type: none"> <li>1. Check connections to the communications board</li> <li>2. Check the master</li> </ol>
<b>F0080 Analog Input - Lost Input Signal</b>	<ul style="list-style-type: none"> <li>• Broken wire</li> <li>• Signal out of limits</li> </ul>	Check connection to analog input
<b>F0085 External Fault</b>	External fault is triggered via terminal inputs	Disable terminal input for fault trigger
<b>F0101 Stack Overflow</b>	Software error or processor failure	<ol style="list-style-type: none"> <li>1. Run self test routines</li> <li>2. Replace drive</li> </ol>
<b>F0221 PI Feedback Below Minimum Value</b>	PID Feedback below minimum value P2268	<ol style="list-style-type: none"> <li>1. Change value of P2268</li> <li>2. Adjust feedback gain</li> </ol>
<b>F0222 PI Feedback Above Maximum Value</b>	PID Feedback above maximum value P2267	<ol style="list-style-type: none"> <li>1. Change value of P2267</li> <li>2. Adjust feedback gain</li> </ol>
<b>F0450 (Service Mode Only) BIST Tests Failure</b>	Fault value <ol style="list-style-type: none"> <li>1 Some of the power section tests have failed</li> <li>2 Some of the control board tests have failed</li> <li>4 Some of the functional tests have failed</li> <li>8 Some of the IO module tests have failed</li> <li>16 The Internal RAM has failed its check on power-up</li> </ol>	<ol style="list-style-type: none"> <li>1. Inverter may run but certain actions will not function correctly</li> <li>2. Replace drive</li> </ol>

LEGEND

- ASIC — Application Specific Instruction
- BIST — Built-in Self Test
- BOP — Basic Operating Panel
- I<sup>2</sup>t — Current Squared Time
- PI — Proportional Integral
- PID — Proportional Integral Derivative

NOTE: To reset the fault code, one of the following methods can be used:

1. Cycle the power to the drive.
2. Press the  button on the operator panel.

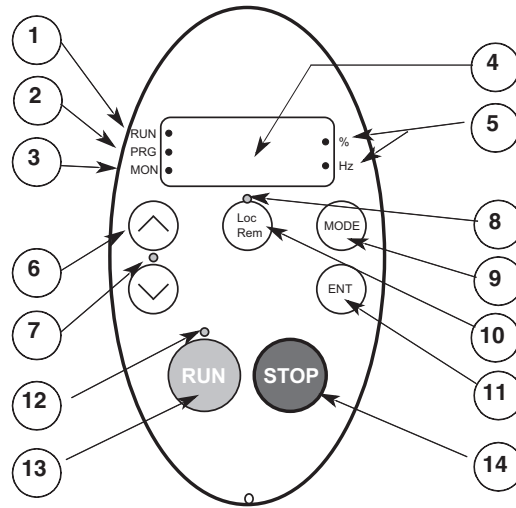


**Table 42 — Siemens Low Ambient Temperature Controller Alarm Messages**

FAULT	POSSIBLE CAUSES	TROUBLESHOOTING
<b>A0501 Current Limit</b>	<ul style="list-style-type: none"> <li>Motor power does not correspond to the drive power</li> <li>Motor leads are too short</li> <li>Ground fault</li> </ul>	<ol style="list-style-type: none"> <li>1. Check whether the motor power corresponds to the drive power</li> <li>2. Check that the cable length limits have not been exceeded</li> <li>3. Check motor cable and motor for short-circuits and ground faults</li> <li>4. Check whether the motor parameters correspond with the motor being used</li> <li>5. Check the stator resistance</li> <li>6. Increase the ramp-up-time</li> <li>7. Reduce the boost</li> <li>8. Check whether the motor is obstructed or overloaded</li> </ol>
<b>A0502 Overvoltage Limit</b>	<ul style="list-style-type: none"> <li>Mains supply too high</li> <li>Load regenerative</li> <li>Ramp-down time too short</li> </ul>	<ol style="list-style-type: none"> <li>1. Check that mains supply voltage is within allowable range</li> <li>2. Increase ramp down times</li> </ol> <p>NOTE: If the vdc-max controller is active, ramp-down times will be automatically increased</p>
<b>A0503 Undervoltage Limit</b>	<ul style="list-style-type: none"> <li>Mains supply too low</li> <li>Short mains interruption</li> </ul>	Check main supply voltage (P0210)
<b>A0504 Drive Overtemperature</b>	Warning level of inverter heat-sink temperature (P0614) is exceeded, resulting in pulse frequency reduction and/or output frequency reduction (depending on parameters set (P0610))	<ol style="list-style-type: none"> <li>1. Check if ambient temperature is within specified limits</li> <li>2. Check load conditions and duty cycle</li> <li>3. Check if fan is turning when drive is running</li> </ol>
<b>A0505 Drive I<sup>2</sup>t</b>	Warning level is exceeded; current will be reduced if parameters set (P0610 = 1)	Check if duty cycle is within specified limits
<b>A0506 Drive Duty Cycle</b>	Heatsink temperature and thermal junction model are outside of allowable range	Check if duty cycle is within specified limits
<b>A0511 Motor Overtemperature I<sup>2</sup>t</b>	Motor overloaded	<p>Check the following:</p> <ol style="list-style-type: none"> <li>1. P0611 (motor I<sup>2</sup>t time constant) should be set to appropriate value</li> <li>2. P0614 (motor I<sup>2</sup>t overload warning level) should be set to suitable level</li> <li>3. Are long periods of operation at low speed occurring</li> <li>4. Check that boost settings are not too high</li> </ol>
<b>A0541 Motor Data Identification Active</b>	Motor data identification (P1910) selected or running	Wait until motor identification is finished
<b>A0600 RTOS Overrun Warning</b>	Software error	—

LEGEND

I<sup>2</sup>t — Current Squared Time  
 RTOS — Run Time Operating System



CALL OUT	LED/KEY	DESCRIPTION
1	Display RUN LED	Illuminates when a run command is applied to the drive controller. Flashes when a speed reference is present with the run command.
2	Display PRG LED	Illuminates when Programming mode is active. Flashes when -GrU menus are active.
3	Display MON LED	Illuminates when Monitoring mode is active. Flashes in fault record display mode.
4	Display Unit	4 digits, 7 segments
5	Display Unit LED	The % LED illuminates when a displayed numeric value is a percentage. The Hz LED illuminates when a displayed numeric value is in hertz.
6	Up/Down arrows	Depending on the mode, use the arrows to: navigate between the menus, change a value, or change the speed reference when Up/Down LED (7) is lit.
7	Up/Down LED	Illuminates when the Up/Down arrows are controlling the speed reference.
8	Loc/Rem LED	Illuminates when Local mode is selected.

CALL OUT	LED/KEY	DESCRIPTION
9	MODE	Press to select the Keypad mode. Modes are: Run mode (default on power-up), Programming mode, and Monitoring mode. Can also be used to go back to the previous menu.
10	Loc/Rem	Switches between Local and Remote modes.
11	ENT	Press to display a parameter's value or to save a changed value.
12	RUN LED	Illuminates when the Run key is enabled.
13	RUN	Pressing this key when the RUN LED is illuminated starts the drive controller.
14	STOP	Stop/reset key. In Local mode, pressing the STOP key causes the drive controller to stop based on the setting of parameter F721. In Remote mode, pressing the STOP key causes the drive controller to stop based on the setting of parameter F603. The display will indicate a flashing "E". If F735 is set to 0 (default setting), pressing the stop key twice will reset all resettable faults if the fault condition has been resolved.

**Fig. 37 — Schnieder Altivar 21 VFD Display Panel**

**Table 43 — Schnieder Altivar 21 VFD Operating Parameters**

PARAMETER	NAME	VALUE
<b>uLu</b>	Rated Motor Voltage	Nominal motor voltage(V) from rating plate
<b>F201</b>	VIA Speed Reference Level 1	5
<b>F202</b>	VIA Output Frequency Level 1	0
<b>F203</b>	VIA Speed Reference Level 2	100
<b>F204</b>	VIA Output Frequency Level 2	60
<b>F401</b>	Slip compensation	60%
<b>F415</b>	Rated Motor Current	Nominal motor current(A) from rating plate
<b>F417</b>	Rated Motor Speed	Nominal motor speed(RPM) from rating plate
<b>F701</b>	Keypad display: % or A/V	1
<b>tHr</b>	Motor Rated Current Overload Setting	Nominal motor current(A) from rating plate
<b>uL</b>	Rated Motor Frequency	60 Hz
<b>FH</b>	Maximum Frequency	60 Hz
<b>LL</b>	Low Speed	0 Hz
<b>UL</b>	High Speed	60 Hz
<b>ACC</b>	Ramp-up Time	10 Sec
<b>dEC</b>	Ramp-down Time	10 Sec
<b>cnod</b>	Remote Mode Start/Stop Control	0 (Control terminal logic inputs)
<b>fnod</b>	Remote Mode Primary Speed reference Source	1 (VIA)

**PRE-START-UP**

**IMPORTANT:** Complete the Start-Up Checklist for 30XA Liquid Chillers at the end of this publication. The checklist assures proper start-up of a unit, and provides a record of unit condition, application requirements, system information, and operation at initial start-up.

Do not attempt to start the chiller until the following checks have been completed.

**System Check**

1. Check auxiliary components, such as the chilled fluid circulating pump, air-handling equipment, or other equipment to which the chiller supplies liquid are operational. Consult manufacturer’s instructions. If the unit has field-installed accessories, be sure all are properly installed and wired correctly. Refer to unit wiring diagrams.
2. Open compressor suction service valves (if equipped).
3. Open discharge line, liquid line, oil line, and economizer (if equipped) service valves.
4. Fill the chiller fluid circuit with clean water (with recommended inhibitor added) or other non-corrosive fluid to be cooled. Bleed all air out of high points of system. If outdoor temperatures are expected to be below 32 F (0° C), and unit has a flooded cooler option, sufficient inhibited propylene glycol or other suitable corrosion inhibited anti-freeze should be added to the chiller water circuit to prevent possible freeze-up.

The chilled water loop must be cleaned before the unit is connected. Units supplied with the accessory hydronic package include a run-in screen. If the run-in screen is left in the suction guide/strainer, it is recommended that the Service Maintenance be set to alert the operator within 24 hours of start-up to be sure that the run-in screen in the suction guide/strainer is removed. To set the time for the parameter, go to **Water Filter Ctrl (days), W.FIL**. Values for this item are counted as days. Refer to the hydronic pump package literature if unit is equipped with the optional hydronic pump package.

5. Check tightness of all electrical connections.

6. Electrical power source must agree with unit nameplate.
7. Oil separator heaters must be firmly seated under the oil separator, and must be energized for 24 hours prior to start-up.
8. Verify power supply phase sequence. Fan motors are 3 phase. Check rotation of non low-ambient controlled fans by using the quick test. Fan rotation is counterclockwise as viewed from top of unit. If fan is not turning counterclockwise, reverse 2 of the power wires at the main terminal block.
9. Perform service test to verify proper operation.

**START-UP**

**⚠ CAUTION**

Do not manually operate contactors. Serious damage to the machine may result.

**Actual Start-Up** — *Actual start-up should be done only under supervision of a qualified refrigeration technician.*

1. Be sure all oil, suction valves, discharge valves (if equipped) and liquid line service valves are open.
2. Using the unit control, set leaving-fluid set point (**Cooling Setpoint 1, CSP1**). No cooling range adjustment is necessary.
3. If optional control functions or accessories are being used, the unit must be properly configured. Refer to Configuration Options section for details.
4. Start the chilled fluid pump, if unit is not configured for pump control. (**Cooler Pumps Sequence, PUMP=0**)
5. Complete the Start-Up Checklist to verify all components are operating properly.
6. If unit is equipped with navigator turn Enable/Off/Remote contact switch to Enable position. If unit is equipped with Touch Pilot press the Start/Stop button and select Local On.
7. Allow unit to operate and confirm that everything is functioning properly. Check to see that leaving fluid temperature agrees with leaving set point Control Point (**Control Point, CTPT**).

## Operating Limitations

TEMPERATURES — Unit operating temperature limits are listed in the table below.

TEMPERATURE	F	C
Maximum Ambient Temperature	125	52
Minimum Ambient Temperature	32	0
Maximum Cooler EWT*	95	35
Maximum Cooler LWT	60	15
Minimum Cooler LWT†	40	4.4

### LEGEND

EWT — Entering Fluid (Water) Temperature  
LWT — Leaving Fluid (Water) Temperature

\*For sustained operation, EWT should not exceed 70 F (21.1 C).  
†Unit requires brine modification for operation below this temperature.

**Low Ambient Temperature Operation** — If unit operating temperatures below 32 F (0° C) are expected, refer to separate unit installation instructions for low ambient temperature operation using accessory low ambient temperature head pressure control, if not equipped. Contact your Carrier representative for details.

NOTE: If wind velocity is expected to be greater than 5 mph (8 km/h) wind baffles and brackets must be field-fabricated and installed for all units using accessory low ambient head pressure control. See the 30XA Installation Instructions or the low ambient temperature head pressure control accessory installation instructions for more information.

### ⚠ CAUTION

Brine duty application (below 40 F [4.4 C] LCWT) for chiller normally requires factory modification. Contact a Carrier Representative for details regarding specific applications. Operation below 40 F (4.4 C) LCWT without modification can result in compressor failure.

## VOLTAGE

**Main Power Supply** — Minimum and maximum acceptable supply voltages are listed in the Installation Instructions.

**Unbalanced 3-Phase Supply Voltage** — Never operate a motor where a phase imbalance between phases is greater than 2%.

To determine percent voltage imbalance:

$$\% \text{ Voltage Imbalance} = 100 \times \frac{\text{max voltage deviation from avg voltage}}{\text{average voltage}}$$

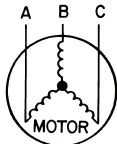
The maximum voltage deviation is the largest difference between a voltage measurement across 2 legs and the average across all 3 legs.

Example: Supply voltage is 240-3-60.

AB = 243v

BC = 236v

AC = 238v



1. Determine average voltage:

$$\begin{aligned} \text{Average voltage} &= \frac{243+236+238}{3} \\ &= \frac{717}{3} \\ &= 239 \end{aligned}$$

2. Determine maximum deviation from average voltage:

$$(AB) 243 - 239 = 4 \text{ v}$$

$$(BC) 239 - 236 = 3 \text{ v}$$

$$(AC) 239 - 238 = 1 \text{ v}$$

Maximum deviation is 4 v.

3. Determine percent voltage imbalance:

$$\begin{aligned} \% \text{ Voltage Imbalance} &= 100 \times \frac{4}{239} \\ &= 1.7\% \end{aligned}$$

This voltage imbalance is satisfactory as it is below the maximum allowable of 2%.

**IMPORTANT:** If the supply voltage phase imbalance is more than 2%, contact the local electric utility company immediately. Do not operate unit until imbalance condition is corrected.

**MINIMUM FLUID LOOP VOLUME** — To obtain proper temperature control, loop fluid volume must be at least 3 gallons per ton (3.25 L per kW) of chiller nominal capacity for air conditioning and at least 6 gallons per ton (6.5 L per kW) for process applications or systems that must operate at low ambient temperatures (below 32 F [0° C]). Refer to application information in Product Data literature for details.

**FLOW RATE REQUIREMENTS** — Standard chillers should be applied with nominal flow rates within those listed in the Minimum and Maximum Cooler Flow Rates table. Higher or lower flow rates are permissible to obtain lower or higher temperature rises. Minimum flow rates must be exceeded to assure turbulent flow and proper heat transfer in the cooler. See Table 44. See Fig. 38A-38D for cooler pressure drop curves.

### ⚠ CAUTION

Operation below minimum flow rate could generate alarms, which could result in damage to the cooler.

Consult application data section in the Product Data literature and job design requirements to determine flow rate requirements for a particular installation.

**Table 44 — 30XA Minimum and Maximum Cooler Flow Rates**

ITEM				MINIMUM		MAXIMUM		
Cooler Leaving Water Temperature*				40 F (4.4 C)		60 F (15 C)		
Cooler Entering Water Temperature†				45 F (7.2 C)		70 F (21.1 C)		
30XA UNIT SIZE	Nominal Flow Rate		Cooler	Number of Passes	Minimum Flow Rate		Maximum Flow Rate	
	(gpm)	(L/s)			(gpm)	(L/s)	(gpm)	(L/s)
80	180.4	11.4	Standard, Flooded	2	95	6	379	23.9
			Plus One Pass, Flooded	3	43	2.7	192	12.1
			Minus One Pass, Flooded	1	196	12.4	782	49.3
82	172.8	10.9	DX Cooler	—	86	5.4	346	21.8
			Standard, Flooded	2	101	6.4	403	25.4
90	201.9	12.7	Plus One Pass, Flooded	3	43	2.7	200	12.6
			Minus One Pass, Flooded	1	229	14.4	917	57.9
			DX Cooler	—	97	6.1	387	24.4
100	225.5	14.2	Standard, Flooded	2	101	6.4	403	25.4
			Plus One Pass, Flooded	3	43	2.7	200	12.6
			Minus One Pass, Flooded	1	229	14.4	917	57.9
102	214.3	13.5	DX Cooler	—	107	6.7	429	27.0
			Standard, Flooded	2	125	7.9	501	31.6
110	244.9	15.5	Plus One Pass, Flooded	3	61	3.8	244	15.4
			Minus One Pass, Flooded	1	254	16	1014	64
			DX Cooler	—	118	7.4	470	29.6
120	264.8	16.7	Standard, Flooded	2	125	7.9	501	31.6
			Plus One Pass, Flooded	3	73	4.6	293	18.5
			Minus One Pass, Flooded	1	281	17.7	1124	70.9
122	254.7	16.0	DX Cooler	—	127	8.0	509	32.1
			Standard, Flooded	2	134	8.5	538	33.9
140	317.8	20.1	Plus One Pass, Flooded	3	73	4.6	293	18.5
			Minus One Pass, Flooded	1	324	20.4	1296	81.8
			DX Cooler	—	152	9.6	607	38.2
160	365.1	23	Standard, Flooded	2	165	10.4	660	41.6
			Plus One Pass, Flooded	3	98	6.2	391	24.7
			Minus One Pass, Flooded	1	354	22.3	1418	89.5
162	347	21.9	DX Cooler	—	174	10.9	694	43.7
			Standard, Flooded	2	202	12.7	807	50.9
180	409.6	25.8	Plus One Pass, Flooded	3	73	4.6	391	24.7
			Minus One Pass, Flooded	1	416	26.2	1662	104.9
			DX Cooler	—	201	12.6	803	50.6
200	463.9	29.3	Standard, Flooded	2	223	14.1	892	56.3
			Plus One Pass, Flooded	3	98	6.2	391	24.7
			Minus One Pass, Flooded	1	458	28.9	1833	115.6
202	447.1	28.2	DX Cooler	—	224	14.1	894	56.3
			Standard, Flooded	2	235	14.8	941	59.4
220	505.9	31.9	Plus One Pass, Flooded	3	122	7.7	489	30.9
			Minus One Pass, Flooded	1	501	31.6	2004	126.4
			DX Cooler	—	246	15.5	950	59.9
222	493	31.1	Standard, Flooded	2	266	16.8	1063	67.1
			Plus One Pass, Flooded	3	147	9.3	587	37
240	545.8	34.4	Minus One Pass, Flooded	1	538	33.9	2151	135.7
			DX Cooler	—	265	16.7	950	59.9
			Standard, Flooded	2	257	16.2	1027	64.8
260	600.3	37.9	Plus One Pass, Flooded	3	141	8.9	562	35.5
			Minus One Pass, Flooded	1	584	36.8	2334	147.3
			DX Cooler	—	292	18.4	950	59.9
280	642.2	40.5	Standard, Flooded	2	293	18.5	1173	74
			Plus One Pass, Flooded	3	141	8.9	562	35.5
			Minus One Pass, Flooded	1	620	39.1	2481	156.5
282	627	39.5	DX Cooler	—	313	19.8	950	59.9
			Standard, Flooded	2	327	20.6	1308	82.5
300	687.5	43.4	Plus One Pass, Flooded	3	174	11	697	44
			Minus One Pass, Flooded	1	687	43.3	2750	173.5
			DX Cooler	—	333	21.0	1331	83.9
325	733.4	46.3	Standard, Flooded	2	361	22.8	1442	91
			Plus One Pass, Flooded	3	211	13.3	843	53.2
			Minus One Pass, Flooded	1	724	45.7	2897	182.8
327	720	45.4	DX Cooler	—	360	22.7	1440	90.8
			Standard, Flooded	2	379	23.9	1516	95.6
350	775.4	48.9	Plus One Pass, Flooded	3	244	15.4	978	61.7
			Minus One Pass, Flooded	1	767	48.4	3068	193.6
			DX Cooler	—	379	23.9	1514	95.5
400	917.6	57.9	Standard, Flooded	1	501	31.6	2004	126.4
			Plus One Pass, Flooded	—	—	—	—	—
			Minus One Pass, Flooded	—	—	—	—	—
450	1019.3	64.3	Standard, Flooded	1	501	31.6	2004	126.4
			Plus One Pass, Flooded	—	—	—	—	—
			Minus One Pass, Flooded	—	—	—	—	—
500	1092.8	68.9	Standard, Flooded	1	501	31.6	2004	126.4
			Plus One Pass, Flooded	—	—	—	—	—
			Minus One Pass, Flooded	—	—	—	—	—

**LEGEND**

**DX** — Direct Expansion

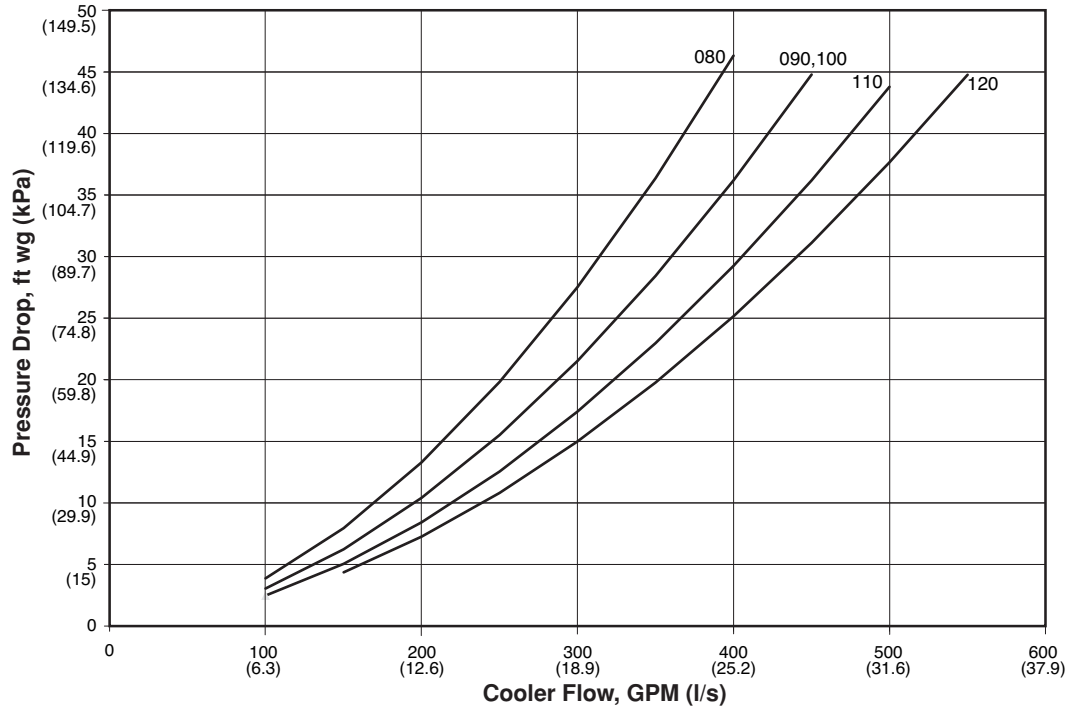
\*For applications requiring cooler leaving water temperature operation at less than 40 F (4.4 C), the units require the use of antifreeze and application may require the brine option. Contact your local Carrier representative for more information.

†For applications requiring cooler entering water temperature operation at less than 45 F (7.2 C), contact your local Carrier representative for unit selection using the Carrier electronic catalog.

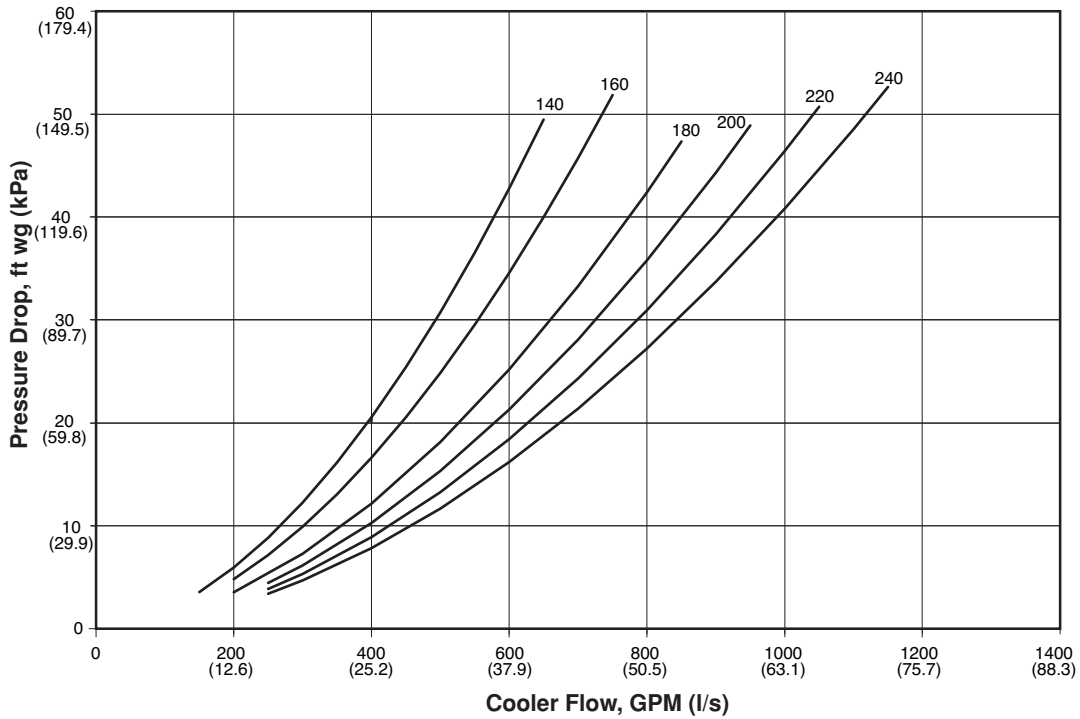
**NOTES:**

1. The 30XA units will start and pull down with loop temperatures up to 95 F (35 C).
2. Nominal flow rates required at AHRI conditions 44 F (7 C) leaving fluid temperature, 54 F (12 C) entering water temperature, 95 F (35 C) ambient. Fouling factor 0.00010 ft<sup>2</sup>-hr-F/Btu (0.000018 m<sup>2</sup>-K/kW).
3. To obtain proper temperature control, cooler loop fluid volume must be at least 3 gal/ton (3.23 L/kW) of chiller nominal capacity for air conditioning and at least 6 gal/ton (6.5 L/kW) for process applications or systems that must operate in low ambient temperatures (below 32 F [0° C]).

**Unit Sizes 30XA080, 90, 100, 110, 120**



**Unit Sizes 30XA140, 160, 180, 200, 220, 240**



**Fig. 38A — Cooler Pressure Drop Curves, Standard Pass Flooded Cooler**

Unit Sizes 30XA260, 280, 300, 325, 350, 400, 450, 500

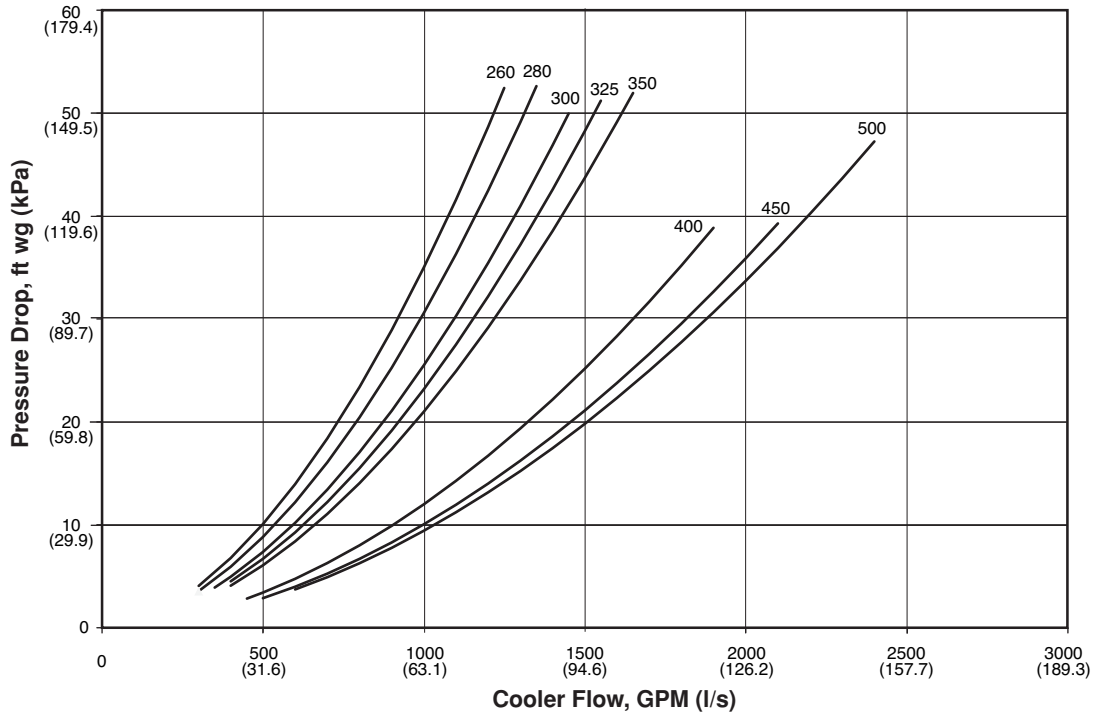


Fig. 38A — Cooler Pressure Drop Curves, Standard Pass Flooded Cooler (cont)

Unit Sizes 30XA082, 092, 102, 112, 122, 142, 162, 182, 202

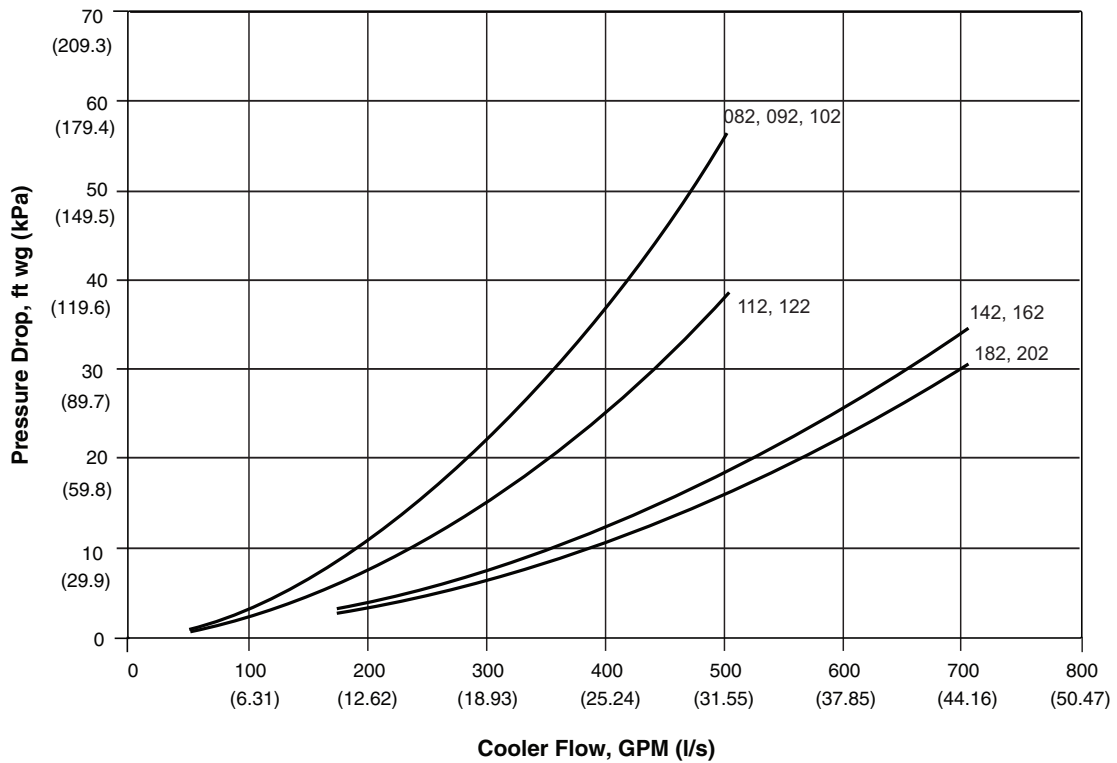


Fig. 38B — Cooler Pressure Drop Curves, DX (Direct Expansion) Cooler

Unit Sizes 30XA222, 242, 262, 282, 302, 327, 352

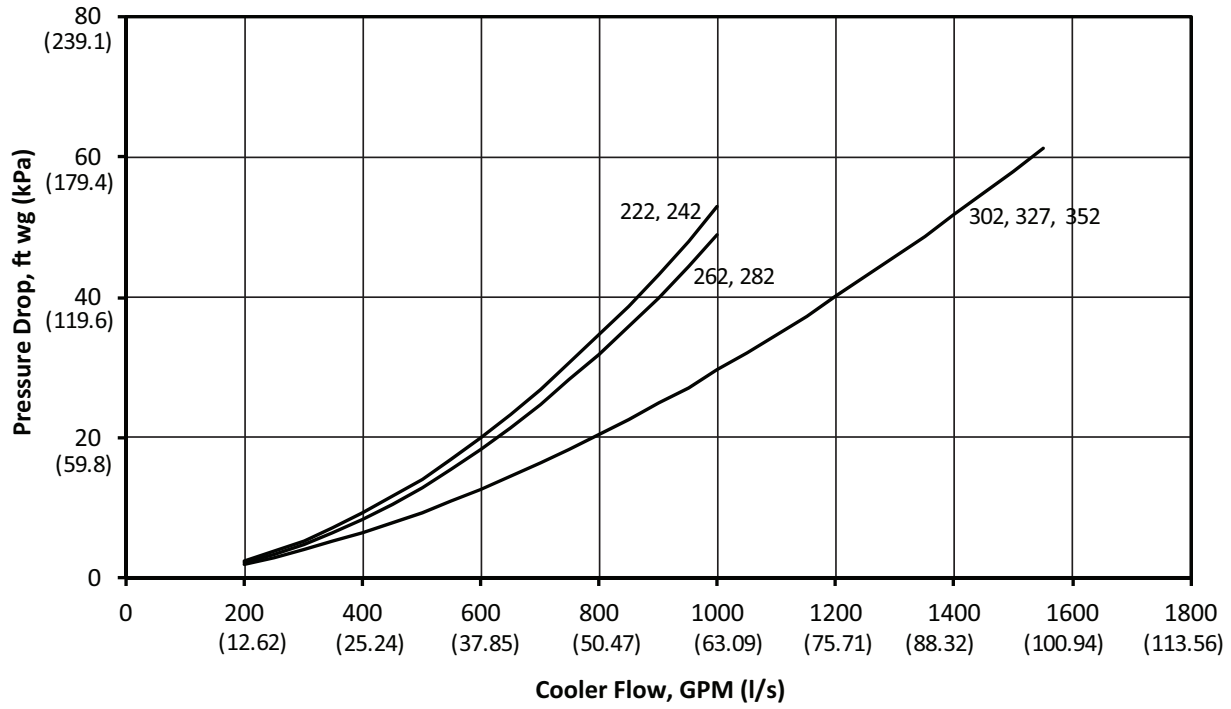


Fig. 38B — Cooler Pressure Drop Curves, DX (Direct Expansion) Cooler (cont)

Unit Sizes 30XA080, 090, 100, 110, 120

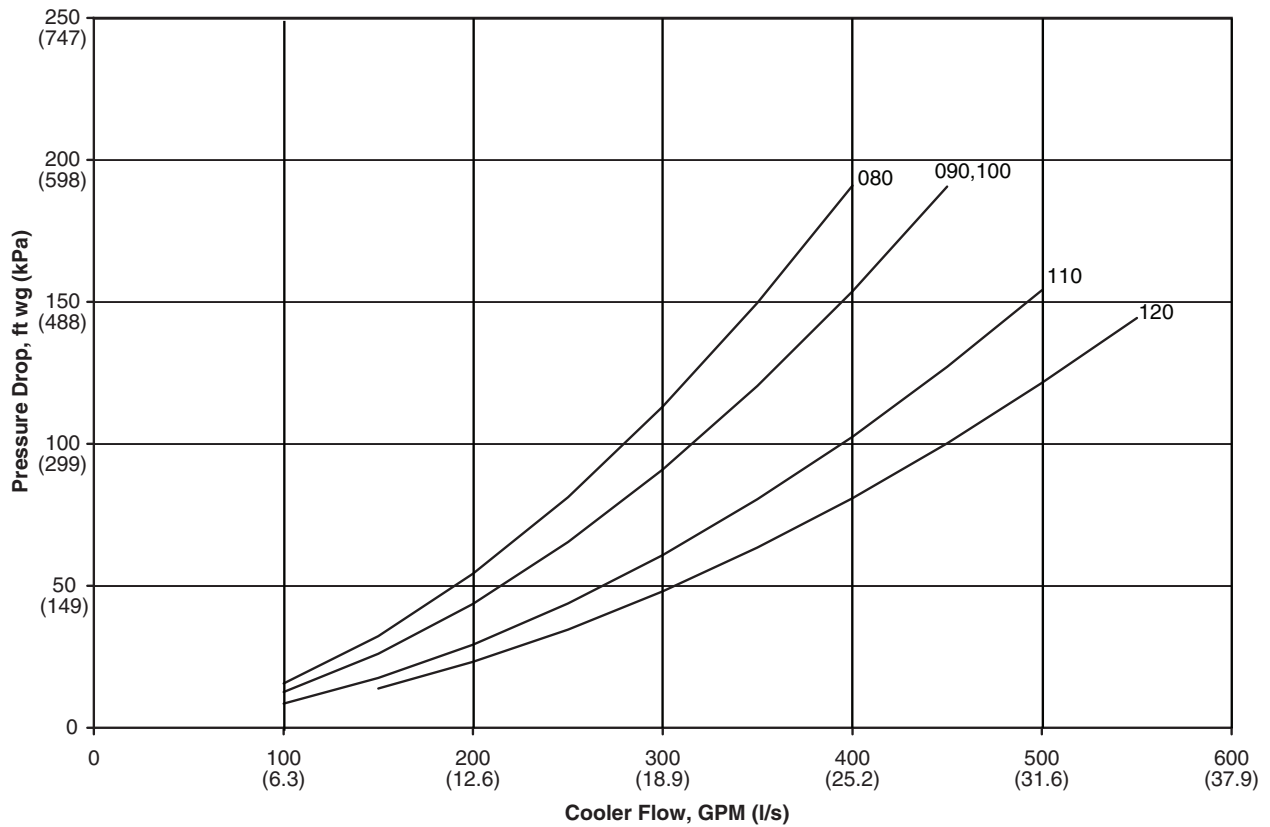
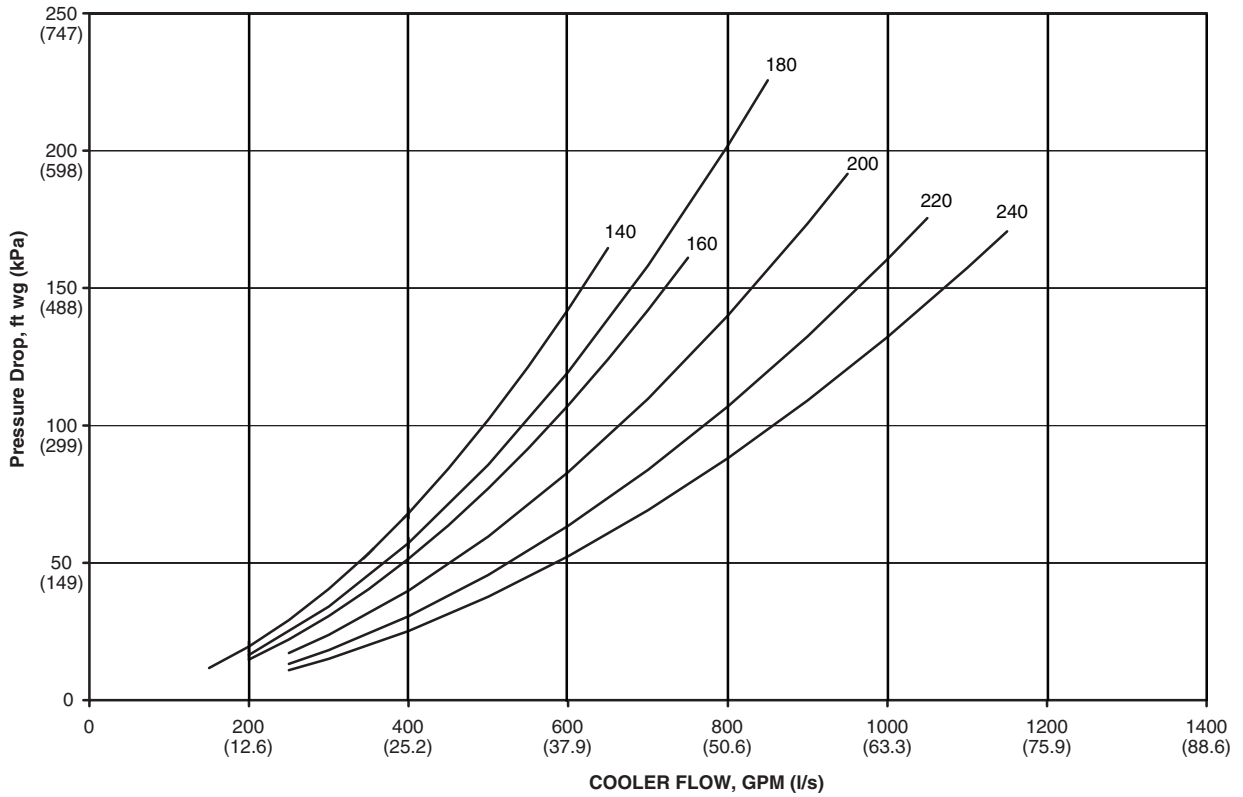


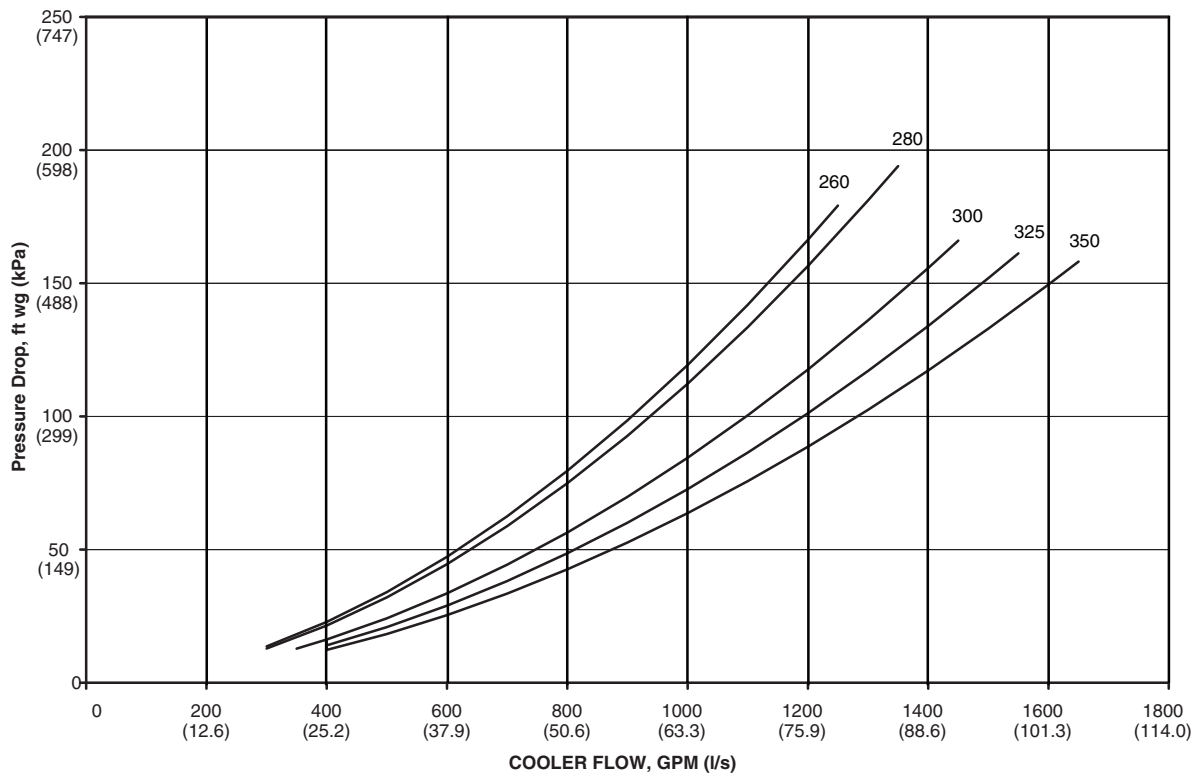
Fig. 38C — Cooler Pressure Drop Curves, Plus One-Pass Flooded Cooler



**Unit Sizes 30XA140, 160, 180, 200, 220, 240**



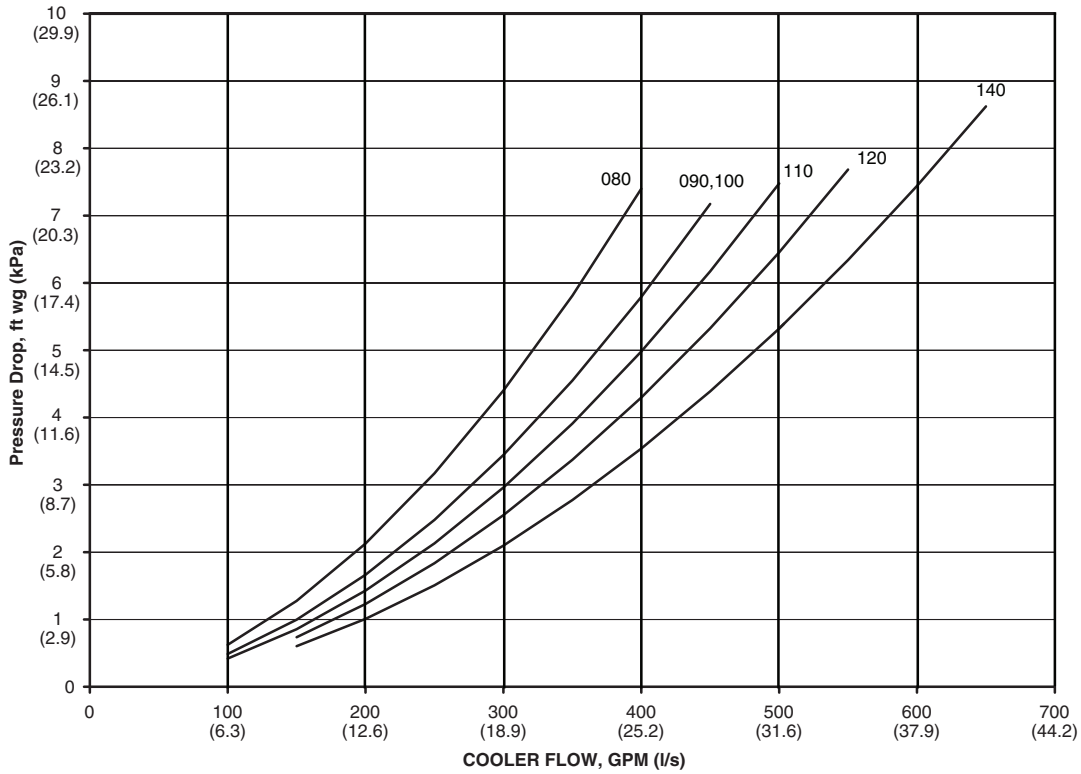
**Unit Sizes 30XA260, 280, 300, 325, 350**



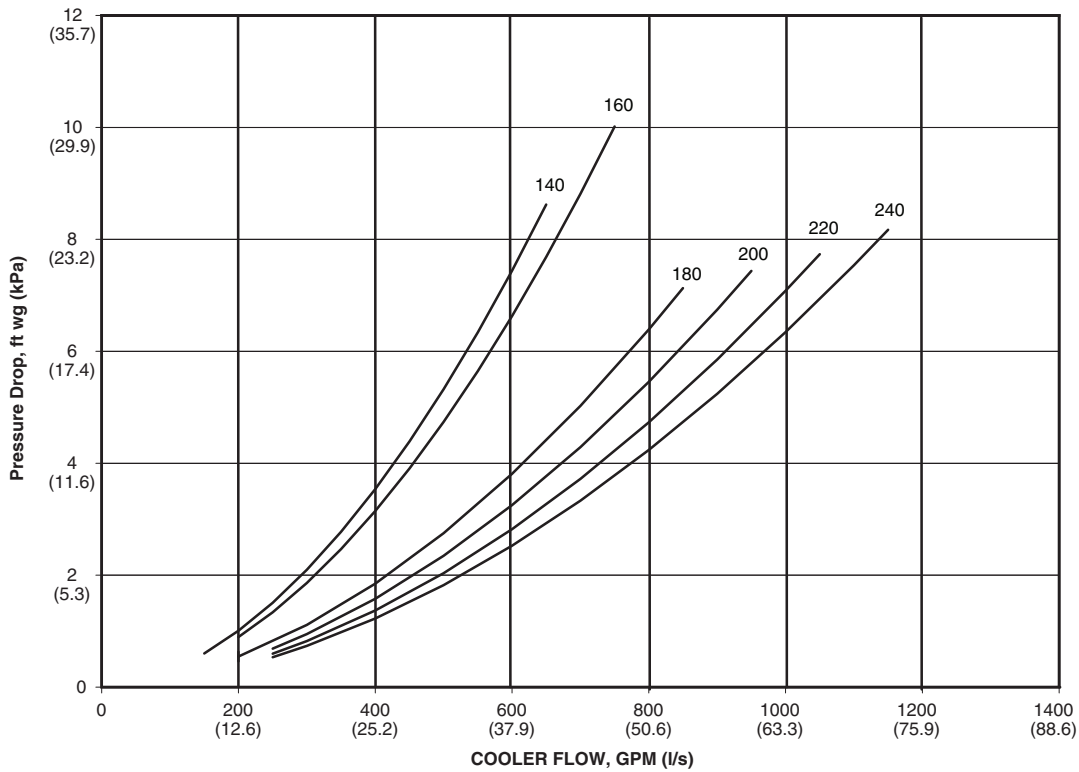
NOTE: Plus-one-pass coolers are not available for 30XA400-500 units.

**Fig. 38C — Cooler Pressure Drop Curves, Plus One-Pass Flooded Cooler (cont)**

**Unit Sizes 30XA080, 090, 100, 110, 120, 140**



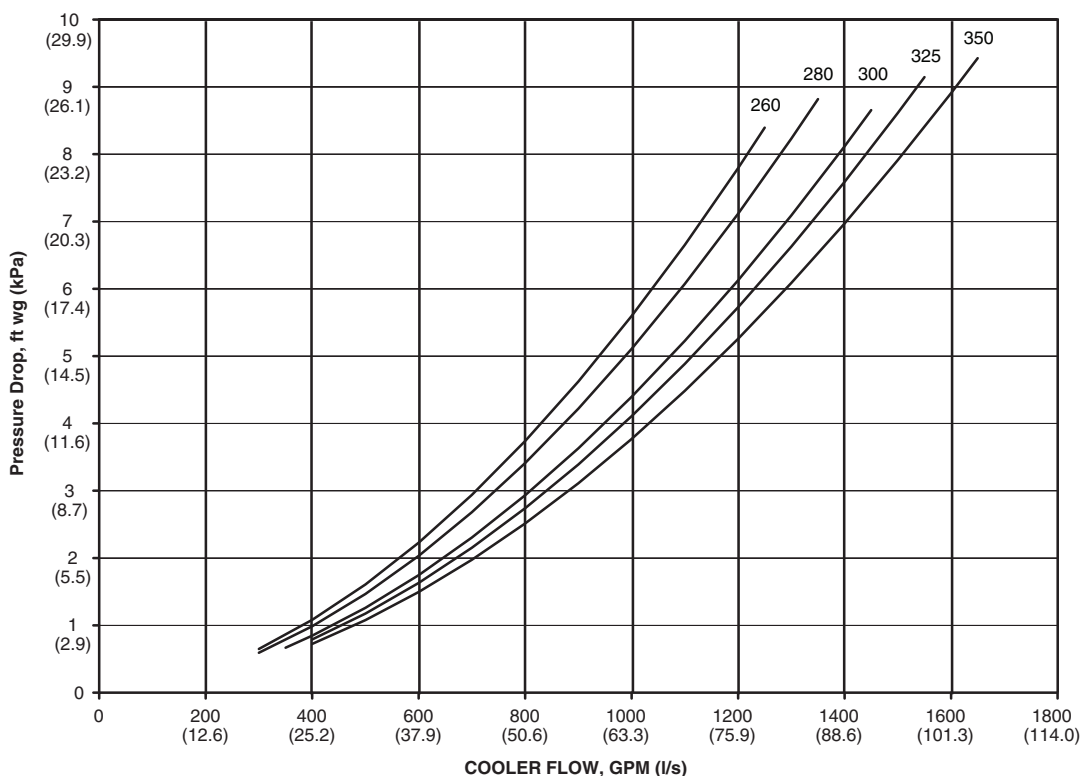
**Unit Sizes 30XA140, 160, 180, 200, 220, 240**



NOTE: Minus-one-pass coolers are not available for 30XA400-500 units.

**Fig. 38D — Cooler Pressure Drop Curves, Minus One-Pass Flooded Cooler**

## Unit Sizes 30XA260, 280, 300, 325, 350



NOTE: Minus-one-pass coolers are not available for 30XA400-500 units.

**Fig. 38D — Cooler Pressure Drop Curves, Minus One-Pass Flooded Cooler (cont)**

## OPERATION

**Sequence of Operation** — With a command to start the chiller, the cooler pump will start. After verifying water flow, the control will monitor the entering and leaving water temperature. If the need for mechanical cooling is determined, the control decides which circuit and compressor to start. The control will start the required compressor completely unloaded and deenergize the oil separator heater (if already energized). The control will continue to load this circuit by moving the slide valve to satisfy cooling requirements. Once fully loaded, the control will start additional circuits to satisfy the load as required. Shutdown of each circuit under normal conditions occurs in the opposite sequence to loading. Once the A circuit is fully unloaded the compressor is shut off and the EXV will close completely.

If the outside-air temperature is less than the brine freeze point plus 17° F (9.4° C) then the circuit will perform a pump down cycle. The EXV will be closed and the compressor continues to operate until the saturated suction temperature (SST) is 10° F (5.6° C) lower than the starting SST or 10° F (5.6° C) less than the brine freeze point. Once the compressor is shut off the actuated ball valve (located in the discharge line) will be closed if equipped (flooded cooler option units only).

**ACTUATED BALL VALVE (ABV), FLOODED COOLER ONLY** — There is either one or two discharge ABVs located in the discharge line of each circuit of the unit. See Fig. 39 for a typical ABV assembly with enclosure. The ABV is a motorized ball valve, which is used to close the discharge line to prevent refrigerant migrating from condenser to the cooler when the circuit is off. The valve will be opened before the compressor is started and will normally close when pressure equalizes between suction and discharge lines. If the outside air temperature is less than the brine freeze point plus 17° F (9.4° C) then

the valve will close immediately without waiting for pressure equalization.

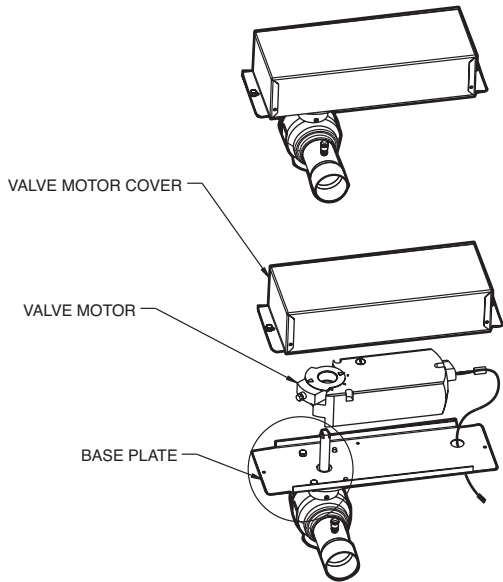
The actuated ball valves are linked to the cooler heater operation in the controls. Cooler Heater option (**Configuration** → **Unit** → **CO.HT**, **SERVICE** → **FACTORY** → **Cooler Heater Select**) must be enabled for the Actuated Ball Valve to operate.

See Fig. 40 for a view of a fully open ball valve with the actuator removed. The flat surface at the top of the valve shaft is parallel to the discharge line. The ball valve motor mounting plate should be perpendicular to the discharge line at all times. If not, adjust it by loosening the set screw on the side of the valve, reposition assembly and tighten set screw.

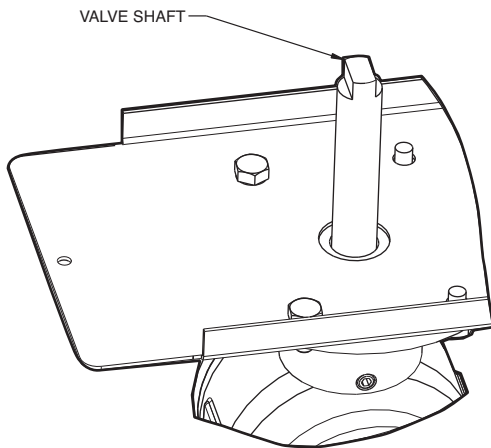
See Fig. 41 for a view of the ball valve motor mounting with a fully open valve. The motor actuator arm should be at a counterclockwise position, with the valve shaft in a parallel position. If not in a parallel position, loosen the clamping screw and push the disengagement button to rotate the actuator arm until it stops. Retighten the clamping screw.

**ABV Manual Operation** — The ABV can be operated manually as a discharge service valve by completing the following steps:

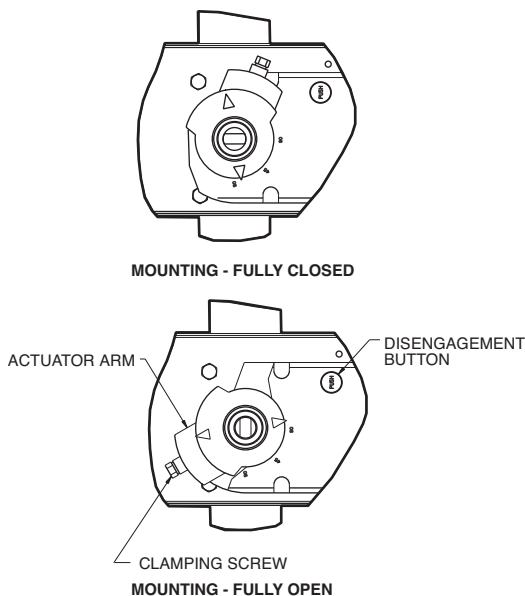
1. Remove the actuator cover.
2. With the compressor off hold down the **Push** button.
3. Close the ABV by turning the shaft adapter by hand or with a wrench so that the flats on the end of the shaft are perpendicular to the discharge line.
4. Release the **Push** button.
5. Disconnect the control power cable to the ABV.



**Fig. 39 — Typical ABV Assembly with Enclosure**



**Fig. 40 — Fully Open Ball Valve with Actuator Removed**



**Fig. 41 — Ball Valve Motor**

**Dual Chiller Sequence of Operation** — With a command to start the chiller, the master chiller determines which chiller will become the lead chiller based on the configuration of **Lead Lag Select, LLBL** and **Lead/Lag Balance Data, LLBD**. The lead chiller is always started first and the lag chiller is held at zero percent capacity by the master chiller forcing the lag demand limit value to 0%. If **Lead Pulldown Time (Lead Pulldown Time, LPUL)** has been configured, the lead chiller will continue to operate alone for that specified time. After the Lead Pulldown Time timer has elapsed and when the lead chiller is fully loaded, either all available compression is on or at the master demand limit value, then the lag start timer (**Lag Start Timer, LLDY**) is initiated. When the pulldown timer and lag start timer has elapsed and the Combined Leaving Chilled Water Temperature is more than 3° F (1.7° C) above the set point, then the lag chiller is started. If the lag chiller's water pump was not started when the machines went into occupied mode, the lag chiller water pump will be started. The lag chiller will start with the master chiller forcing the lag chiller demand limit value (**LAG LIM**) to the master's demand limit value. If lead/lag capacity balance is selected, once the lag chiller has started, the master shall try to keep the difference in capacity between lead and lag less than 20%. The master shall then be responsible for water loop capacity calculation, and will determine which chiller, the lead or lag, will increase or decrease capacity. When the load reduces, the lag chiller will be the first chiller to unload. To accomplish this, the lead chiller set point is decreased by 4° F (-2.2° C) until the lag chiller unloads.

**PUMP OPERATION** — For parallel chiller pump operation, the lead chiller's water pump will be started. The lag chiller's water pump will be maintained off if **Lag Unit Pump Control, LAGP=0**. The internal algorithm of lead chiller will control capacity of the lead chiller.

For series chiller operation, the pump is always controlled by the master chiller.

**Operating Modes** — Operating modes are override modes that affect normal operation of the equipment. More than one operating mode can be in effect at the same time. Some operating modes have corresponding capacity control overrides in the Capacity Control Overrides section on page 47.

For the Touch Pilot™ display, the status of the operating modes can be found in the **MODES** submenu, which is under the **STATUS** menu. Each operating mode and its status (Yes = active, No = inactive) is listed.

For the Navigator™ display, the status of the operating modes can be found in the **MODE** submenu under the **OPERATING MODES** menu. The 6 top priority operating modes are displayed in **MD01** through **MD06**. To view the modes with the Navigator display:

ITEM	ITEM EXPANSION	PATH	VALUE
<b>MD01</b>	First Active Mode	Operating modes→MODE	0-32
<b>MD02</b>	Second Active Mode	Operating modes→MODE	0-32
<b>MD03</b>	Third Active Mode	Operating modes→MODE	0-32
<b>MD04</b>	Fourth Active Mode	Operating modes→MODE	0-32
<b>MD05</b>	Fifth Active Mode	Operating modes→MODE	0-32
<b>MD06</b>	Sixth Active Mode	Operating modes→MODE	0-32

See Table 45 for a list of operating modes.

**STARTUP DELAY IN EFFECT** — This mode is checked for when the unit is started. This mode is active when the Minutes Off Time (**Unit Off to On Delay, DELY**) timer is active. The unit will not start until the timer has expired. The mode will terminate when the timer expires.

**Table 45 — 30XA Operating Modes**

NAVIGATOR OPERATING MODE NUMBER	NAVIGATOR EXPANSION	TOUCH PILOT DISCRPTION	TOUCH PILOT LINE NUMBER	TOUCH PILOT VALUE
01	Startup Delay in Effect	Startup Delay in Effect	2	Yes/No
02	Second Setpoint in Use	Second Setpoint in Use	3	Yes/No
03	Reset in Effect	Reset in Effect	4	Yes/No
04	Demand Limit Active	Demand Limit Active	5	Yes/No
05	Ramp Loading Active	Ramp Loading Active	6	Yes/No
06	Cooler Heater Active	Cooler Heater Active	7	Yes/No
07	Cooler Pumps Rotation	Cooler Pumps Rotation	8	Yes/No
08	Pump Periodic Start	Pump Periodic Start	9	Yes/No
09	Night Low Noise Active	Night Low Noise Active	10	Yes/No
10	System Manager Active	System Manager Active	11	Yes/No
11	Mast Slave Ctrl Active	Mast Slave Active	12	Yes/No
12	Auto Changeover Active	Auto Changeover Active	13	Yes/No
13	Free Cooling Active	Free Cooling Active	14	Yes/No
14	Reclaim Active	Reclaim Active	15	Yes/No
15	Electric Heat Active	Electric Heat Active	16	Yes/No
16	Heating Low EWT Lockout	Heating Low EWT Lockout	17	Yes/No
17	Condenser Pumps Rotation	Condenser Pumps Rotation	18	Yes/No
18	Ice Mode in Effect	Ice Mode in Effect	19	Yes/No
19	Defrost Active on Cir A	Defrost Active on Cir A	20	Yes/No
20	Defrost Active on Cir B	Defrost Active on Cir B	21	Yes/No
21	Low Suction Circuit A	Low Suction Circuit A	22	Yes/No
22	Low Suction Circuit B	Low Suction Circuit B	23	Yes/No
23	Low Suction Circuit C	Low Suction Circuit C	24	Yes/No
24	High DGT Circuit A	High DGT Circuit A	25	Yes/No
25	High DGT Circuit B	High DGT Circuit B	26	Yes/No
26	High DGT Circuit C	High DGT Circuit C	27	Yes/No
27	High Pres Override Cir A	High Pres Override Cir A	28	Yes/No
28	High Pres Override Cir B	High Pres Override Cir B	29	Yes/No
29	High Pres Override Cir C	High Pres Override Cir C	30	Yes/No
30	Low Superheat Circuit A	Low Superheat Circuit A	31	Yes/No
31	Low Superheat Circuit B	Low Superheat Circuit B	32	Yes/No
32	Low Superheat Circuit C	Low Superheat Circuit C	33	Yes/No

**SECOND SETPOINT IN USE** — This mode is checked for when the unit is ON. The mode is active when Cooling Setpoint 2 (**Cooling Setpoint 2, CSP.2**) or Ice Setpoint (**Cooling Ice Setpoint, CSP.3**) is in use. While in this mode, the Active Setpoint (**Current Setpoint, SETP**) will show the **CSP.2** or **CSP.3** value.

While in this mode, the unit will operate to the Cooling Setpoint 2 (**CSP.2**) or Ice Setpoint (**CSP.3**). The mode will terminate when the Cooling Setpoint 2 (**CSP.2**) or Ice Setpoint (**CSP.3**) is no longer in use.

**RESET IN EFFECT** — This mode is checked for when the unit is ON. The mode will be active when Temperature Reset (**Cooling Reset Select, CRST**) is enabled either by **CRST=1** (Outside Air Temperature), **CRST=2** (Return Water), **CRST=3** (4-20 mA Input), or **CRST=4** (Space Temperature) and reset is active.

While in this mode, the Active Setpoint (**Current Setpoint, SETP**) will be modified according to the programmed information and will be displayed as the Control Point (**Control Point, CTPT**). The mode will terminate when the Temperature Reset is not modifying the active leaving water set point, causing **SETP** to be the same as **CTPT**.

**DEMAND LIMIT ACTIVE** — This mode is checked for when the unit is ON. The mode is active when Demand Limit (**Demand Limit Type Select, DMDC**) is enabled either by **DMDC=1** (Switch), **DMDC=2** (4-20 mA Input), or the Night Time Low Sound Capacity Limit (**Capacity Limit, LSLT**).

The Active Demand Limit Value (**Active Demand Limit Val, LIM**) will display the current demand limit according to the programmed information and the unit's capacity will be reduced to the amount shown or lower. The mode will terminate when the Demand Limit command has been removed.

**RAMP LOADING ACTIVE** — This mode is checked for when the unit is ON. The mode is active when Ramp Loading

(**Ramp Loading Select, RLS**) is enabled and the following conditions are met:

1. The leaving water temperature is more than 4° F (2.2° C) from the Control Point (**Control Point, CTPT**), and
2. The rate of change of the leaving water temperature is greater than the Cool Ramp Loading (**Cooling Ramp Loading, CRMP**).

The control will limit the percent capacity increase until one of the two conditions above are no longer met, then the mode will terminate.

**COOLER HEATER ACTIVE** — This mode is checked for whether the unit is ON or OFF. The mode is active when the cooler heater is energized. The cooler heater is energized when the Outdoor Air Temperature (**External Temperature, OAT**) is less than the calculated value, (Freeze Setpoint + Cooler Heater Delta T Setpoint [**Cooler Heater Delta Spt, HTR**] default – 2° F [1.1° C]) and either the Leaving Water Temperature (**Cooler Leaving Fluid, LWT**) or the Entering Water Temperature (**Cooler Entering Fluid, EWT**) are less than or equal to the Freeze Setpoint + Cooler Heater Delta T Setpoint (**HTR**).

The Freeze Setpoint is 34 F (1.1 C), for fresh water systems (**Cooler Fluid Type, FLUD=1**). The Freeze Setpoint is Brine Freeze Setpoint (**Brine Freeze Setpoint, LOSP**), for Medium Temperature Brine systems (**Cooler Fluid Type, FLUD=2**).

When in this mode, the cooler heater will be energized. The cooler heater will be deenergized when both the Entering Water Temperature (**EWT**) and Leaving Water Temperature (**LWT**) are above the Freeze Setpoint + Cooler Heater Delta T Setpoint (**HTR**).

This mode is enabled for freeze protection. If the temperatures are not as described above, check the accuracy of the outside air, entering and leaving water thermistors.

**COOLER PUMPS ROTATION** — This mode is checked for whether the unit is ON or OFF. The mode is active when the

Cooler Pump Sequence (**Cooler Pump Run Status, PUMP=2**) (2 Pumps Automatic Changeover) and the Pump Rotation Delta Timer (**Pump Auto Rotation Delay, ROT.P**) have expired.

The control will switch the operation of the pumps. The lead pump will operate normally. The lag pump will be started, becoming the lead, and then the original lead pump will be shut down. This mode will terminate when the pump operation has been completed.

**PUMP PERIODIC START** — This mode is active when the cooler pump is started due to the Periodic Pump Start configuration (**Pump Sticking Protection, PM.PS=YES**). If the pump has not run that day, a pump will be started and will run for 2 seconds at 2:00 PM. If the machine is equipped with dual pumps, Pump no. 1 will run on even days (such as day 2, 4, 6 of the month). Pump no. 2 will run on odd days (such as day 1, 3, 5 of the month). The mode will terminate when the pump shuts down.

**NIGHT LOW NOISE ACTIVE** — This mode is active when the Night Time Low Noise Option has been configured and the current time is within the configured time frame. Programming a Night Low Noise Start Time (**Start Hour, LS.ST**) and a Night Low Noise End Time (**End Hour, LS.ND**) configures the option.

The control will raise the head pressure set point to reduce the number of condenser fans on, thereby reducing the sound level of the machine. Additionally, if the Night Time Low Sound Capacity Limit (**Start Hour, LS.LT**) has been configured, the unit's capacity will be limited to the programmed level. This mode will terminate once the Night Low Noise End Time (**LS.ND**) has been reached.

**SYSTEM MANAGER ACTIVE** — This mode is checked when the unit is ON or OFF. This mode is active if a System Manager such as Building Supervisor, Chillervisor System Manager, or another CCN device is controlling the machine.

When this mode is active, the machine will respond to the specific commands received from the System Manager. The mode will be terminated if the System Manager control is released.

**MASTER SLAVE CONTROL ACTIVE** — This mode is checked for if the machine is ON. This mode is active if Master Slave Control has been enabled. This occurs when two machines are programmed, one as the master (**Master/Slave Select, MSSL=1** [Master]) and the other as a slave (**Master/Slave Select, MSSL=2** [Slave]).

Both the master and slave machines will respond to the capacity control commands issued by the master controller. This may include control point changes and demand limit commands. This mode will terminate when Master Slave Control has been disabled.

**AUTO CHANGEOVER ACTIVE** — This mode is not supported.

**FREE COOLING ACTIVE** — This mode is not supported.

**RECLAIM ACTIVE** — This mode is not supported.

**ELECTRIC HEAT ACTIVE** — This mode is not supported.

**HEATING LOW EWT LOCKOUT** — This mode is not supported.

**CONDENSER PUMPS ROTATION** — This mode is not supported.

**ICE MODE IN EFFECT** — This mode is checked for when the unit is ON. This mode is active when Ice Setpoint (**Cooling Ice Setpoint, CSP.3**) is in use. While in this mode, the Active Setpoint (**Current Setpoint, SETP**) will show the **Cooling Ice Setpoint, CSP.3**, value and the unit will operate to the Ice

Setpoint (**CSP.3**). This mode will terminate when the Ice Setpoint (**CSP.3**) is no longer in use.

**DEFROST ACTIVE ON CIR A** — This mode is not supported.

**DEFROST ACTIVE ON CIR B** — This mode is not supported.

**LOW SUCTION CIRCUIT A**

**LOW SUCTION CIRCUIT B**

**LOW SUCTION CIRCUIT C** — These modes are checked when the circuit is ON. The appropriate circuit mode will be active if one of the following conditions is true:

1. If the circuit's saturated suction temperature (SST) is more than 6° F (3.3° C) less than the freeze point and both the cooler approach (Leaving Water Temperature – SST) and superheat (Suction Gas Temperature – SST) are greater than 15° F (8.3° C).
2. If the circuit is ON and the circuit's SST is more than 18° F (10.0° C) below the freeze point for more than 90 seconds.
3. If the circuit's saturated suction temperature is more than 6° F (3.3° C) below the freeze point for more than 3 minutes.

For a fresh water system (**Cooler Fluid Type, FLUD =1**), the freeze point is 34° F (1.1° C). For medium temperature brine systems, (**Cooler Fluid Type, FLUD=2**), the freeze point is Brine Freeze Set Point (**Brine Freeze Setpoint, LOSP**).

For criterion 1, no additional capacity will be added. For criteria 2 and 3 capacity will be decreased on the circuit. The mode will terminate when the circuit's SST is greater than the freeze point minus 6° F (3.3° C) or the circuit has alarmed.

If this condition is encountered, see Possible Causes for Alarms 56-58 on page 98.

**HIGH DGT CIRCUIT A** — This mode is not supported.

**HIGH DGT CIRCUIT B** — This mode is not supported.

**HIGH DGT CIRCUIT C** — This mode is not supported.

**HIGH PRES OVERRIDE CIR A**

**HIGH PRES OVERRIDE CIR B**

**HIGH PRES OVERRIDE CIR C** — This mode is checked for when the circuit is ON. The appropriate circuit mode will be active if the discharge pressure for the circuit, Discharge Pressure Circuit A (**Discharge Pressure, DPA**), Discharge Pressure Circuit B (**Discharge Pressure, DPB**), or Discharge Pressure Circuit C (**Discharge Pressure, DPC**), is greater than the High Pressure Threshold (**High Pressure Threshold, HPTH**).

The capacity of the affected circuit will be reduced. Two minutes following the capacity reduction, the circuit's saturated condensing temperature ( $SCT_{t+2}$ ) is calculated and stored. The affected circuit will not be allowed to add capacity for at least 5 minutes following the capacity reduction. If after 5 minutes, the circuit's saturated condensing temperature is less than  $SCT_{t+2} - 3° F$  (1.7° C), and then if required, percent capacity will be added. If additional capacity is required, the control will look for other circuits to add capacity.

This mode will terminate once the circuit's saturated condensing temperature is less than  $SCT_{t+2} - 3° F$  (1.7° C).

If this condition is encountered, see Possible Causes for Alarm A1.03. on page 103.

**LOW SUPERHEAT CIRCUIT A**

**LOW SUPERHEAT CIRCUIT B**

**LOW SUPERHEAT CIRCUIT C** — This mode is checked for when the circuit is ON. The appropriate circuit mode will be active if the circuit's superheat (discharge gas temperature – SCT) is less than 18° F (10° C).



No additional capacity will be added until the circuit's superheat is greater than 18° F (10° C). The control will look for other circuits to add capacity if additional steps of capacity are required. This mode will terminate once the affected circuit's superheat is greater than 18° F (10° C).

If this condition is encountered, see Possible Causes for Alarms P.11, P.12 and P.13 on page 98.

**Sensors** — The electronic control uses up to 17 thermistors to sense temperatures and up to 12 transducers to sense pressure for controlling chiller operation. These sensors are outlined below.

**THERMISTORS (Tables 46-47B)** — Thermistors that are monitoring the chiller's operation include: Cooler Entering Water, Cooler Leaving Water, Dual Chiller Leaving Water, Compressor Suction Gas Temperature, Compressor Discharge Gas Temperature, Economizer Temperature, Compressor Motor Temperature, and Outdoor Air Temperature Thermistors. These thermistors are 5 kΩ at 77 F (25 C) and are identical in temperature versus resistance. The Space Temperature Thermistor is 10 kΩ at 77 F (25 C) and has a different temperature vs. resistance.

**Cooler Leaving Water Sensor** — On all sizes, this thermistor is installed in a friction fit well in the leaving water nozzle of the cooler. See Fig. 42 and 43.

**Cooler Entering Water Sensor** — On all sizes, this thermistor is factory-installed in a friction fit well in the entering water nozzle of the cooler.

**Suction Gas Temperature** — On all sizes, this thermistor is factory-installed in a friction fit well located on the compressor of each circuit. There is one thermistor for each circuit.

**Compressor Discharge Gas Temperature** — On all sizes, this thermistor is factory-installed in a friction fit well located in the discharge end of the compressor for the circuit. There is one thermistor for each circuit.

**Economizer Temperature** — On all sizes except 080 and 082, this thermistor is factory-installed in a friction fit well located in the economizer line for the circuit. There is one thermistor for each circuit.

**Compressor Motor Temperature** — On all sizes, this thermistor is embedded in the motor windings. There are two thermistors in each compressor. One spare is provided.

**Outdoor Air Temperature** — This sensor is factory-installed to the back of the control box.

**Remote Space Temperature** — This sensor (part no. 33ZCT55SPT) is a field-installed accessory mounted in the indoor space and is used for water temperature reset. The sensor should be installed as a wall-mounted thermostat would be (in

the conditioned space where it will not be subjected to either a cooling or heating source or direct exposure to sunlight, and 4 to 5 ft above the floor).

Space temperature sensor wires are to be connected to terminals in the unit main control box. See Fig. 44. The space temperature sensor includes a terminal block (SEN) and a RJ11 female connector. The RJ11 connector is used access into the Carrier Comfort Network® (CCN) at the sensor.

To connect the space temperature sensor (see Fig. 44):

1. Using a 20 AWG twisted pair conductor cable rated for the application, connect one wire of the twisted pair to one SEN terminal and connect the other wire to the other SEN terminal located under the cover of the space temperature sensor.
2. Connect the other ends of the wires to terminals 7 and 8 on TB6 located in the unit control box.

Units on the CCN can be monitored from the space at the sensor through the RJ11 connector, if desired. To wire the RJ11 connector into the CCN:

1. Cut the CCN wire and strip ends of the red (+), white (ground), and black (–) conductors. (If another wire color scheme is used, strip ends of appropriate wires.)
2. Insert and secure the red (+) wire to terminal 5 of the space temperature sensor terminal block.
3. Insert and secure the white (ground) wire to terminal 4 of the space temperature sensor.
4. Insert and secure the black (–) wire to terminal 2 of the space temperature sensor.

**IMPORTANT:** The cable selected for the RJ11 connector wiring **MUST** be identical to the CCN communication bus wire used for the entire network. Refer to Table 14 for acceptable wiring.

5. Connect the other end of the communication bus cable to the remainder of the CCN communication bus.

**NOTE:** The Energy Management Module (EMM) is required for this accessory.

**TRANSDUCERS** — There are four pressure transducers per circuit, and two different types of transducers: low pressure (green connector) and high pressure (black connector).

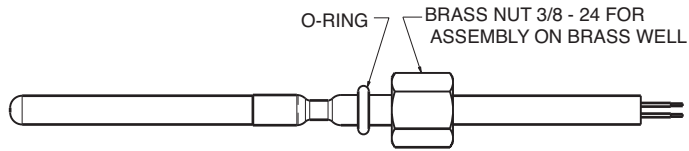
Low Pressure Type: Suction Pressure Transducer (SPT), Economizer Pressure Transducer (EPT).

High Pressure Type: Discharge Pressure Transducer (DPT), Oil Pressure Transducer (OPT). See Fig. 45A and 45B for transducer locations.

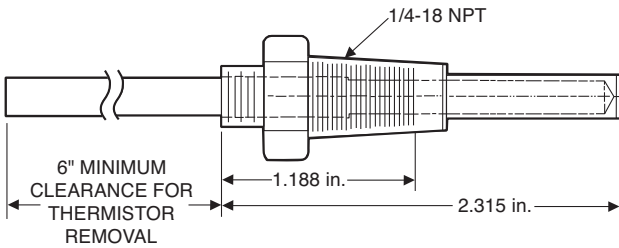
**Table 46 — Thermistor Identification**

THERMISTOR ID	DESCRIPTION	RESISTANCE AT 77 F (25 C)	CONNECTION POINT
EWT	Entering Water Thermistor	5k Ω	MBB-J6-CH2
LWT	Leaving Water Thermistor	5k Ω	MBB-J6-CH1
OAT	Outdoor Air Thermistor	5k Ω	MBB-J6-CH4
SGTA*	Circuit A Suction Gas Thermistor	5k Ω	EXVA-J3-THA
SGTB*	Circuit B Suction Gas Thermistor	5k Ω	EXVB-J3-THA
SGTC	Circuit C Suction Gas Thermistor	5k Ω	EXVC-J3-THA
DGTA	Circuit A Discharge Gas Thermistor	5k Ω	CPM-A-J9-CH02
DGTB	Circuit B Discharge Gas Thermistor	5k Ω	CPM-B-J9-CH02
DGTC	Circuit C Discharge Gas Thermistor	5k Ω	CPM-C-J9-CH02
ECTA	Circuit A Economizer Thermistor	5k Ω	EXVA-J3-THB
ECTB	Circuit B Economizer Thermistor	5k Ω	EXVB-J3-THB
ECTC	Circuit C Economizer Thermistor	5k Ω	EXVC-J3-THB
DUAL	Dual Chiller LWT Thermistor	5k Ω	MBB-J6-CH3
CAMT	Circuit A Motor Temperature	5k Ω	CPM-A-J9-CH01
CBMT	Circuit B Motor Temperature	5k Ω	CPM-B-J9-CH01
CCMT	Circuit C Motor Temperature	5k Ω	CPM-C-J9-CH01
SPT	Space Temperature Thermistor	10k Ω	EMM-J6-CH2

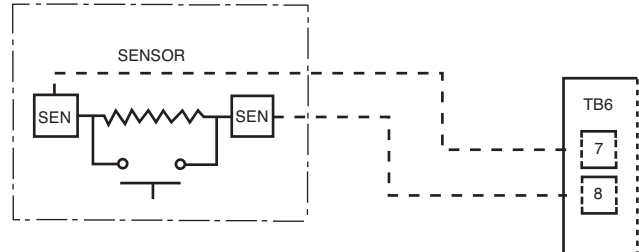
\*SGTA and SGTB for 30XA080,082 units are connected to the EXVA board.



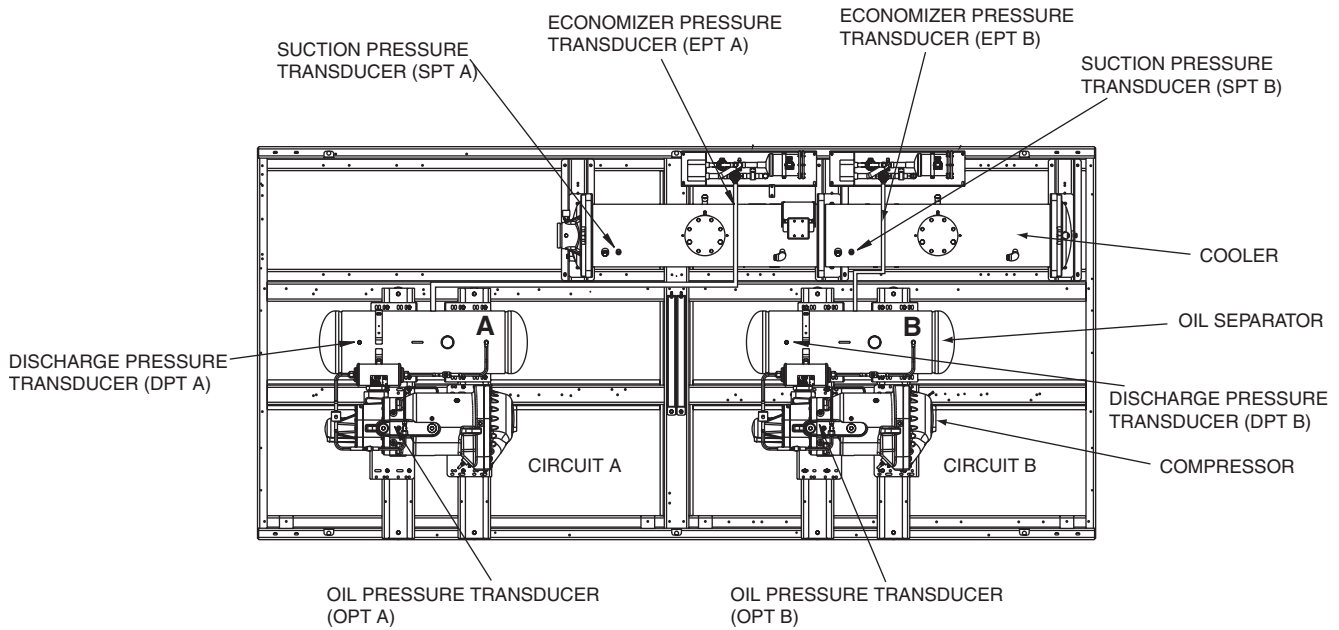
**Fig. 42 — 5K Thermistor (Sensor 00PPG000008105A, Connector: HY06AM016)**



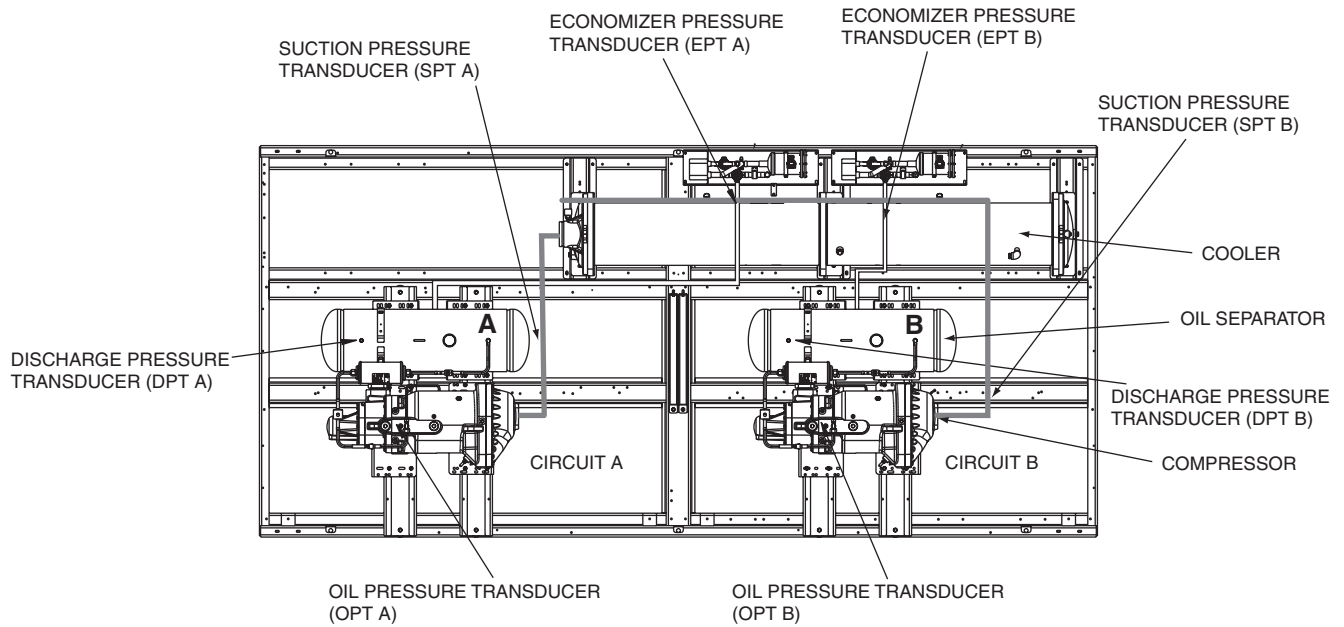
**Fig. 43 — Dual Leaving Water Thermistor Well (00PPG000008000A)**



**Fig. 44 — Typical Remote Space Temperature Sensor (33ZCT55SPT) Wiring**



**Fig. 45A — Transducer Locations (Flooded Cooler Units)**



**Fig. 45B — Transducer Locations (DX Cooler Units)**

**Table 47A — 5K Thermistor Temperature (°F) vs Resistance**

TEMP (F)	RESISTANCE (Ohms)	TEMP (F)	RESISTANCE (Ohms)	TEMP (F)	RESISTANCE (Ohms)	TEMP (F)	RESISTANCE (Ohms)	TEMP (F)	RESISTANCE (Ohms)
-25	98,010	26	19,393	77	4,976	128	1,614	179	570
-24	94,707	27	18,843	78	4,855	129	1,582	180	561
-23	91,522	28	18,311	79	4,737	130	1,550	181	551
-22	88,449	29	17,796	80	4,622	131	1,519	182	542
-21	85,486	30	17,297	81	4,511	132	1,489	183	533
-20	82,627	31	16,814	82	4,403	133	1,459	184	524
-19	79,871	32	16,346	83	4,298	134	1,430	185	516
-18	77,212	33	15,892	84	4,196	135	1,401	186	508
-17	74,648	34	15,453	85	4,096	136	1,373	187	501
-16	72,175	35	15,027	86	4,000	137	1,345	188	494
-15	69,790	36	14,614	87	3,906	138	1,318	189	487
-14	67,490	37	14,214	88	3,814	139	1,291	190	480
-13	65,272	38	13,826	89	3,726	140	1,265	191	473
-12	63,133	39	13,449	90	3,640	141	1,240	192	467
-11	61,070	40	13,084	91	3,556	142	1,214	193	461
-10	59,081	41	12,730	92	3,474	143	1,190	194	456
-9	57,162	42	12,387	93	3,395	144	1,165	195	450
-8	55,311	43	12,053	94	3,318	145	1,141	196	445
-7	53,526	44	11,730	95	3,243	146	1,118	197	439
-6	51,804	45	11,416	96	3,170	147	1,095	198	434
-5	50,143	46	11,112	97	3,099	148	1,072	199	429
-4	48,541	47	10,816	98	3,031	149	1,050	200	424
-3	46,996	48	10,529	99	2,964	150	1,029	201	419
-2	45,505	49	10,250	100	2,898	151	1,007	202	415
-1	44,066	50	9,979	101	2,835	152	986	203	410
0	42,679	51	9,717	102	2,773	153	965	204	405
1	41,339	52	9,461	103	2,713	154	945	205	401
2	40,047	53	9,213	104	2,655	155	925	206	396
3	38,800	54	8,973	105	2,597	156	906	207	391
4	37,596	55	8,739	106	2,542	157	887	208	386
5	36,435	56	8,511	107	2,488	158	868	209	382
6	35,313	57	8,291	108	2,436	159	850	210	377
7	34,231	58	8,076	109	2,385	160	832	211	372
8	33,185	59	7,866	110	2,335	161	815	212	367
9	32,176	60	7,665	111	2,286	162	798	213	361
10	31,202	61	7,468	112	2,239	163	782	214	356
11	30,260	62	7,277	113	2,192	164	765	215	350
12	29,351	63	7,091	114	2,147	165	750	216	344
13	28,473	64	6,911	115	2,103	166	734	217	338
14	27,624	65	6,735	116	2,060	167	719	218	332
15	26,804	66	6,564	117	2,018	168	705	219	325
16	26,011	67	6,399	118	1,977	169	690	220	318
17	25,245	68	6,238	119	1,937	170	677	221	311
18	24,505	69	6,081	120	1,898	171	663	222	304
19	23,789	70	5,929	121	1,860	172	650	223	297
20	23,096	71	5,781	122	1,822	173	638	224	289
21	22,427	72	5,637	123	1,786	174	626	225	282
22	21,779	73	5,497	124	1,750	175	614		
23	21,153	74	5,361	125	1,715	176	602		
24	20,547	75	5,229	126	1,680	177	591		
25	19,960	76	5,101	127	1,647	178	581		

**Table 47B — 5K Thermistor Temperature (°C) vs Resistance/Voltage**

TEMP (C)	RESISTANCE (Ohms)	TEMP (C)	RESISTANCE (Ohms)	TEMP (C)	RESISTANCE (Ohms)
-32	100,260	15	7,855	62	1,158
-31	94,165	16	7,499	63	1,118
-30	88,480	17	7,161	64	1,079
-29	83,170	18	6,840	65	1,041
-28	78,125	19	6,536	66	1,006
-27	73,580	20	6,246	67	971
-26	69,250	21	5,971	68	938
-25	65,205	22	5,710	69	906
-24	61,420	23	5,461	70	876
-23	57,875	24	5,225	71	836
-22	54,555	25	5,000	72	805
-21	51,450	26	4,786	73	775
-20	48,536	27	4,583	74	747
-19	45,807	28	4,389	75	719
-18	43,247	29	4,204	76	693
-17	40,845	30	4,028	77	669
-16	38,592	31	3,861	78	645
-15	38,476	32	3,701	79	623
-14	34,489	33	3,549	80	602
-13	32,621	34	3,404	81	583
-12	30,866	35	3,266	82	564
-11	29,216	36	3,134	83	547
-10	27,633	37	3,008	84	531
-9	26,202	38	2,888	85	516
-8	24,827	39	2,773	86	502
-7	23,532	40	2,663	87	489
-6	22,313	41	2,559	88	477
-5	21,163	42	2,459	89	466
-4	20,079	43	2,363	90	456
-3	19,058	44	2,272	91	446
-2	18,094	45	2,184	92	436
-1	17,184	46	2,101	93	427
0	16,325	47	2,021	94	419
1	15,515	48	1,944	95	410
2	14,749	49	1,871	96	402
3	14,026	50	1,801	97	393
4	13,342	51	1,734	98	385
5	12,696	52	1,670	99	376
6	12,085	53	1,609	100	367
7	11,506	54	1,550	101	357
8	10,959	55	1,493	102	346
9	10,441	56	1,439	103	335
10	9,949	57	1,387	104	324
11	9,485	58	1,337	105	312
12	9,044	59	1,290	106	299
13	8,627	60	1,244	107	285
14	8,231	61	1,200		

**SERVICE**

**Economizer Assembly** — Each circuit on the 30XA090-500 units has an economizer assembly. The 30XA080,082 units do not have an economizer and have one main electronic expansion valve. The 30XA080,082 units are controlled the same way as units with a separate economizer assembly. See Fig. 46.

**Electronic Expansion Valve (EXV)** — See Fig. 47 for a cutaway view of the EXV. High-pressure liquid refrigerant enters valve through the top. As refrigerant passes through the orifice, pressure drops and refrigerant changes to a 2-phase condition (liquid and vapor). The electronic expansion valve operates through an electronically controlled activation of a stepper motor. The stepper motor stays in position unless power pulses initiate the two discrete sets of motor stator windings for rotation in either direction. The direction depends on the phase relationship of the power pulses.

The motor directly operates the spindle, which has rotating movements that are transformed into linear motion by the transmission in the cage assembly. The valve cone is a V-port type which includes a positive shut-off when closed.

The large number of steps and long stroke results in very accurate control of the refrigerant flow. The stepper motor has either 3690 (main) or 2785 (economizer) steps.

**FLOODED COOLER MAIN EXV CONTROL** — Each circuit has a thermistor located in the discharge end of the compressor (DGT) and another one located in the compressor motor cavity (SGT). Each circuit also has discharge and suction

pressure transducer. Discharge and suction pressure as measured by the transducers are converted to saturated temperatures. The main control logic for the EXV uses discharge superheat to control the position of the EXV. The difference between the temperature of the discharge gas and the saturated discharge temperature is the superheat. The EXV module controls the position of the electronic expansion valve stepper motor to maintain the discharge superheat set point.

The EXV control logic has several overrides, which are also used to control the position of the EXV.

- Approach between SST (Saturated Suction Temperature) and LWT
- Maximum Operating Pressure (MOP)

**Approach** — If the approach (pinch), which is the difference between leaving fluid temperature and saturated suction temperature, is equal to or less than the pinch set point then the EXV will not open any further even though discharge superheat set point is not met. Pinch set point is calculated using suction superheat, discharge superheat and pinch offset. Pinch offset is used to adjust calculated pinch set point to accuracy of transducers and thermistors.

**MOP** — The EXV is also used to limit cooler saturated suction temperature to 62 F (16.6 C). This makes it possible for the chiller to start at higher cooler fluid temperatures without overloading the compressor. This is commonly referred to as MOP (maximum operating pressure). If the SST is equal to or greater than the MOP set point then the MBB will try to control the EXV position to maintain the MOP set point.

The discharge superheat leaving the compressor is maintained between approximately 18° and 25° F (10° and 14° C), or less. Because EXV status is communicated to the Main Base Board (MBB) and is controlled by the EXV modules, it is possible to track the valve position. The unit is then protected against loss of charge and a faulty valve. During initial start-up, the EXV is fully closed. After an initialization period, valve position is tracked by the EXV module by constantly monitoring the amount of valve movement.

**DX (Direct Expansion) COOLER MAIN EXV CONTROL** — Each circuit has a thermistor located in a well in the discharge of the compressor (DGT) and another one located in the compressor motor cavity (SGT). Thermistors are also located in a well in the water inlet and outlet nozzles. Apart from thermistors, each circuit also has a discharge and suction pressure transducer. Discharge and suction pressures as measured by the transducers are converted to saturated temperatures. The main control logic for the EXV uses approach temperature in the cooler (Water Inlet Temperature – Saturated Suction Temperature) and suction superheat (Suction Temperature – Saturated Suction Temperature) to control the position of the EXV. The EXV module controls the position of the electronic expansion valve stepper motor to maintain a minimum approach and a suction superheat set point.

The EXV control logic has several overrides, which are also used to control the position of the EXV.

- Maximum Operating Pressure (MOP)
- High Discharge Gas Temperature
- Low Discharge Superheat

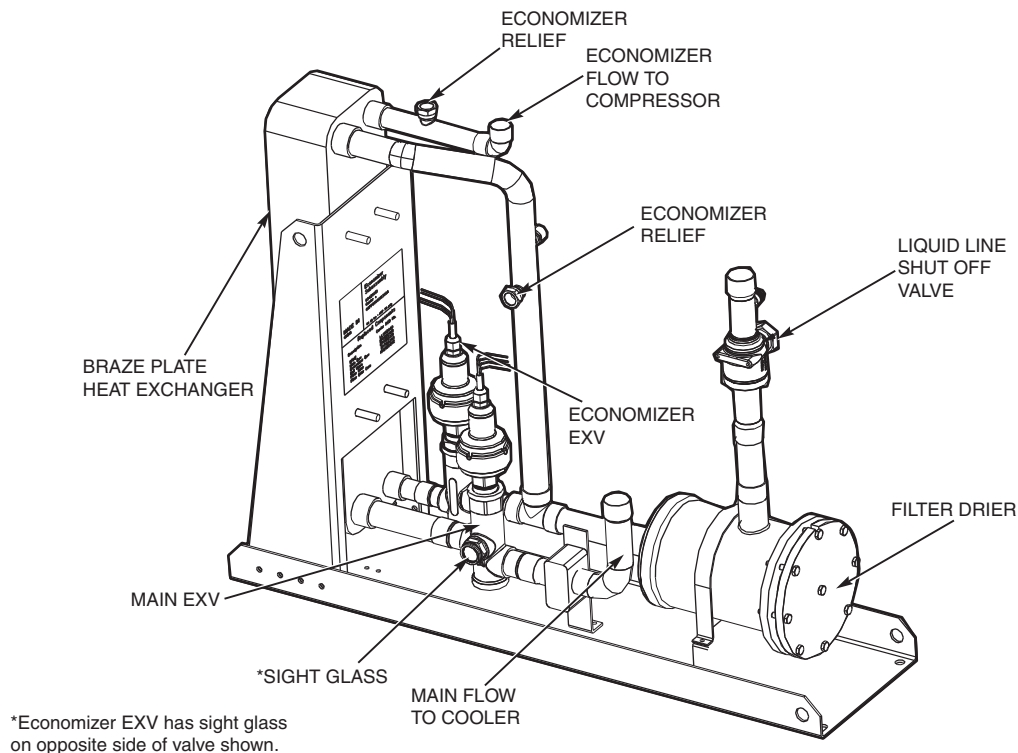
**MOP** — The EXV is also used to limit cooler saturated suction temperature to 62 F (16.6 C). This makes it possible for the

chiller to start at higher cooler fluid temperatures without overloading the compressor. This is commonly referred to as MOP (maximum operating pressure). If the SST (Saturated Suction Temperature) is equal to or greater than the MOP set point then the MBB will try to control the EXV position to maintain the MOP set point.

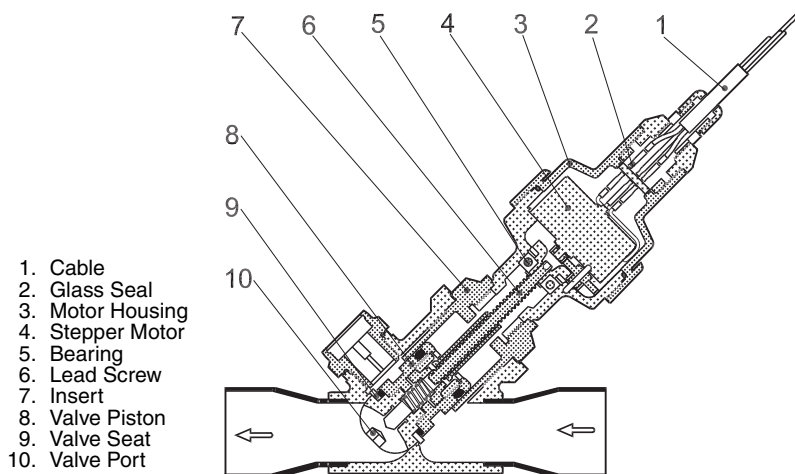
**High Discharge Gas Temperature** — The EXV is also used to limit the discharge gas temperature to 200 F (93.3 C). This makes it possible for the chiller to operate at low load and high ambient temperature without overloading the compressor. If the DGT is approaching the High DGT limit then the control will try to control the EXV position to bring the DGT down by opening the EXV.

**Low Discharge Superheat** — The EXV is also used to limit the discharge superheat (DSH) to 18° F (10° C). This makes it possible for the chiller to operate at high load and low ambient temperature without overloading the compressor. If the DSH goes below 18° F (10° C) the MBB will try to control the EXV position to bring the discharge superheat up by closing the EXV valve.

The suction superheat entering the compressor is maintained between approximately 15° and 25° F (8.3° and 14° C) while maintaining a constant approach in the cooler. Because EXV status is communicated to the Main Base Board (MBB) and is controlled by the EXV modules, it is possible to track the valve position. During initial start-up, the EXV is fully closed. After an initialization period, valve position is tracked by the EXV module by constantly monitoring the amount of valve movement.



**Fig. 46 — Economizer Assembly**



**Fig. 47 — Cutaway Views of the Electronic Expansion Valve**

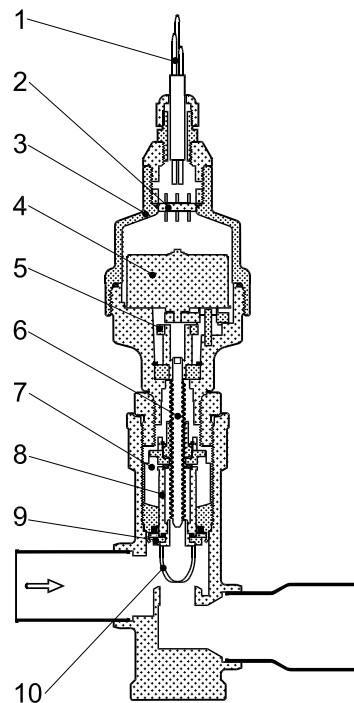
**ECONOMIZER EXV CONTROL** — The economizer EXV is controlled by the circuit EXV board. There is an economizer gas temperature thermistor and economizer pressure transducer located in the line, which runs from the economizer assembly to the compressor. The economizer pressure is converted to saturated temperature and is used to calculate economizer superheat. Economizer superheat equals economizer temperature minus saturated economizer temperature. The economizer EXV only operates during normal conditions when the capacity of the circuit is greater than 75%. Once the capacity of the circuit is greater than 75% the MBB will start controlling the economizer EXV to maintain economizer superheat set point, which is approximately 8° to 12° F (4.4° to 6.7° C). If the circuit capacity is less than 75%, the economizer EXV will be closed.

The economizer EXV has one override. If the discharge gas temperature exceeds 195 F (90.6 C) the economizer EXV will start to open. The EXV will be controlled to maintain discharge gas temperature at approximately 195 F (90.6 C).

If it appears that main EXV or economizer EXV is not properly controlling circuit operation to maintain correct superheat, there are a number of checks that can be made using test functions and initialization features built into the microprocessor control. See the Service Test section to test EXVs.

**EXV TROUBLESHOOTING PROCEDURE** — There are two different economizer EXVs. Both of the economizer EXVs have a total of 2785 steps. There are three different main EXVs, which all have a total of 3690 steps. The EXV motor moves at 150 steps per second. Commanding the valve to either 0% or 100% will add an additional 160 steps to the move, to ensure the valve is open or closed completely.

Follow the steps below to diagnose and correct EXV problems. Check EXV motor operation first. Switch the Enable/Off/Remote (EOR) Contact switch to the Off position. Check the appropriate circuit EXV, Circuit A EXV % Open (**Circuit A EXV Position, EXV.A**), Circuit B EXV % Open (**Circuit B EXV Position, EXV.B**), or Circuit C EXV % Open (**Circuit C EXV Position, EXV.C**). The current value of 0 will be displayed. Increase the EXV position to select 100% valve position. The actuator should be felt moving through the EXV. To close the valve, select 0%. The actuator should knock when it reaches the bottom of its stroke. See Table 48 for a list of EXV modes and submodes.



If the valve is not working properly, continue with the following test procedure:

Check the 8-position DIP switch on the board for the proper address (see page 11). Check the EXV output signals at appropriate terminals on the EXV module. For 30XA080 units, connect the positive test lead to EXV-J2A terminal 5 for Circuit A and to EXV-J2B terminal 5 for Circuit B.

For 30XA090-500 units connect positive test lead to EXV(X)-J2A terminal 5 for EXV(X) and EXV(X)-J2B terminal 5 for Economizer EXV(X). Using the Service Test procedure on page 105, move the valve output under test to 100%. DO NOT short meter leads together or pin 5 to any other pin, as board damage will occur. During the next several seconds, carefully connect the negative test lead to pins 1,2,3 and 4 in succession. Digital voltmeters will average this signal and display approximately 6 vdc. If the output remains at a constant voltage other than 6 vdc or shows 0 volts, remove the connector to the valve and recheck.

Select 0% to close the valve.

**NOTE:** Twelve vdc is the output from the EXV board when the valve is stationary.

See Tables 6 and 7. If a problem still exists, replace the EXV board. If the reading is correct, the expansion valve and EXV wiring should be checked. Check the EXV connector and interconnecting wiring.

1. Check color-coding and wire connections. Make sure they are connected to the correct terminals at the EXV board and EXV plug and that the cables are not crossed.
2. Check for continuity and tight connection at all pin terminals.

Check the resistance of the EXV motor windings. For 30XA080,082 units remove the EXV module plug EXV-J2A for Circuit A EXV and EXV-J2B for Circuit B EXV. For 30XA090-500 units remove the EXV module plug EXV(X)-J2A for main EXV and EXV(X)-J2B for economizer EXV. Check the resistance of the two windings between pins 1 and 3 for one winding and pins 2 and 4 for the other winding. The resistance should be 52 ohms ( $\pm 5.2$  ohms). Also check pins 1-4 for any shorts to ground.



**Table 48 — EXV Modes and Submodes**

EXV TYPE AND CIRCUIT	TOUCH PILOT™ PATH	NAVIGATOR™ PATH
EXV, Circuit A	Main Menu→Status→CIRCA_AN	Service Test Mode→QUIC→EXV.A
EXV, Circuit B	Main Menu→Status→CIRCB_AN	Service Test Mode→QUIC→EXV.B
EXV, Circuit C	Main Menu→Status→CIRCC_AN	Service Test Mode→QUIC→EXV.C
Economizer EXV, Circuit A	Main Menu→Status→QCK_TST1	Service Test Mode→QUIC→ECO.A
Economizer EXV, Circuit B	Main Menu→Status→QCK_TST1	Service Test Mode→QUIC→ECO.B
Economizer EXV, Circuit C	Main Menu→Status→QCK_TST1	Service Test Mode→QUIC→ECO.C

Inspecting/Opening Electronic Expansion Valves

**IMPORTANT:** Obtain replacement gaskets before opening EXV. Do not re-use gaskets.

To check the physical operation of an EXV, the following steps must be performed if the unit does not have service valve option or activated ball valves (ABV) (flooded coolers only) the complete charge needs to be recovered using proper recovery techniques Steps 1-3 shown below. If the unit has ABV or discharge service valves, only perform Steps 1 and 2.

1. Close the liquid line service valve of the circuit to be checked. Put the Enable/Off/Remote Contact switch in the Off position. Enter the Service Test mode and change **Service Test Enable, T.REQ** from **OFF** to **ON**. A password may be required. Switch the EOR switch to the Enable position. Under the COMP sub-mode, enable one of the compressors (**CP.xn**) for the circuit. Let compressor run until gage on suction pressure port reads 10 psig (68.9 kPa). Turn the compressor off. The compressor will turn off. Immediately after the compressor shuts off, manually close the actuated ball valve (ABV) (see the Actuated Ball Valve section for instructions). If the unit is equipped with suction service valves, discharge service valve, and economizer service valves, close all valves. Closing the valves will minimize the amount of charge that will have to be removed from the system after pump down.
2. Remove any remaining refrigerant from the system low side using proper recovering techniques. The economizer assembly has a 1/4-in. access connection which can be used to remove charge from the inlet of the EXVs. Turn off the line voltage power supply to the compressors.

**⚠ CAUTION**

Ensure refrigerant is removed from both the inlet and outlet of EXV assemblies. Equipment damage could result.

3. The expansion valve motor is hermetically sealed inside the top portion of the valve. See Fig. 47. Disconnect the EXV plug. Carefully unscrew the motor portion from the body of the valve. The EXV operator will come out with the motor portion of the device. Reconnect the EXV plug.
4. Enter the appropriate EXV test step under the (**QUIC**) Service Test mode Locate the desired item **Circuit A EXV Position, EXV.A, Circuit B EXV Position, EXV.B, or Circuit C EXV Position, EXV.C**. Change the position to 100%. Observe the operation of the lead screw. See Fig. 47. The motor should be turning, raising the operator closer to the motor. Motor actuator movement should be smooth and uniform from fully closed to fully open position. Select 0% and check open to closed operation. If the valve is properly connected to the processor and receiving correct signals, yet does not operate as described above, the sealed motor portion of the valve should be replaced.

Installing EXV Motor

**IMPORTANT:** Obtain replacement gasket before opening EXV. Do not re-use gaskets.

If re-installing the motor, be sure to use a new gasket in the assembly. See Fig. 48. It is easier to install the motor assembly with the piston in the fully closed position. Insert the motor into the body of the EXV. Tighten the motor to the body to 36 ft-lb (50 N-m) and then tighten the valve another 30 degrees.

**Moisture Liquid Indicator** — Clear flow of liquid refrigerant indicates sufficient charge in system. Bubbles in the sight glass indicate undercharged system or presence of noncondensables. Moisture in system, measured in parts per million (ppm), changes color of indicator. See Table 49. Change filter drier at first sign of moisture in system.

**Table 49 — Color Indicators when Moisture is Present in Refrigerant**

COLOR INDICATOR	R-134A, 75 F (24 C) (ppm)	R-134A, 125 F (52 C) (ppm)
Green — Dry	<30	<45
Yellow-green — Caution	30-100	45-170
Yellow — Wet	>100	>170

**IMPORTANT:** Unit must be in operation at least 12 hours before moisture indicator can give an accurate reading.

With unit running, indicating element must be in contact with liquid refrigerant to give true reading.

**Filter Drier** — Whenever moisture-liquid indicator shows presence of moisture, replace filter drier(s). There is one filter drier assembly on each circuit with either one or two cores. The 30XA080-122 units have one core per circuit. The 30XA140-162 units have two cores, in circuit A and one for circuit B. The 30XA180-500 units have two cores per circuit. Refer to the Carrier Standard Service Techniques Manual, Chapter 1, Refrigerants, for details on servicing filter driers.

**Liquid Line Service Valve** — This valve is located immediately ahead of filter drier, and has a 1/4-in. access connection for field charging. In combination with compressor discharge service valve, each circuit can be pumped down into the high side for servicing.

**Compressor Assembly** — The 30XA units utilize screw compressors with a modulating slide valve which varies capacity from 30% to 100% of compressor capacity for each circuit. See Fig. 49 for a view of a typical 06T compressor. The slide valve position is varied by opening and closing the 2 solenoid valves located on the compressor. To unload the compressor, both solenoids are deenergized. To increase in capacity both solenoid valves are energized together which will cause the slide valve to slide towards the fully loaded position. To stop the loading process solenoid 2 is energized and solenoid 1 is deenergized. This will cause the slide valve to maintain its current position. There is no feedback for the position of the slide valve. The control utilizes compressor current

as an indicator of the slide valve position. Once the calculated position of the slide valve reaches 100% circuit capacity, the control will try to increase capacity again if the compressor current continues to increase. The control will continue to load the compressor until the compressor current no longer increases. At that time the control will energize both solenoids and the circuit will be considered fully loaded.

**COMPRESSOR OIL SYSTEM** — Each compressor/circuit has its own oil system which includes an oil filter, oil solenoid, check valve, oil level switch, oil separator heater, oil pressure transducer, and an oil shut-off valve. A typical oil system is shown in Fig. 50. See Table 50.

**Table 50 — Unit Oil Quantities**

30XA UNIT SIZE	OIL CHANGE (gal, [liters])		
	Circuit A	Circuit B	Circuit C
080-122	5.5 [20.8]	5.5 [20.8]	—
140-162	6.25 [23.7]	5.5 [20.8]	—
180-202	6.25 [23.7]	6.25 [23.7]	—
220,222	6.75 [25.6]	6.25 [23.7]	—
240,242	6.75 [25.6]	6.75 [25.6]	—
260,262	7.50 [28.4]	6.75 [25.6]	—
280-302	7.50 [28.4]	6.75 [25.6]	—
325-352	7.50 [28.4]	7.50 [28.4]	—
400	6.75 [25.6]	6.75 [25.6]	7.50 [28.4]
450	7.50 [28.4]	6.25 [23.7]	7.50 [28.4]
500	7.50 [28.4]	6.75 [25.6]	7.50 [28.4]

**Oil Charge** — When additional oil or a complete charge is required it must meet the following specifications:

- Manufacturer . . . . . Emkarate RL220XL
- Oil Type . . . . . Inhibited polyolester-based synthetic compressor lubricant for use with screw compressors.

- ISO Viscosity Grade . . . . . 220

Do not reuse drained oil or any oil that has been exposed to the atmosphere.

Oil is available in the following quantities from your local Carrier representative:

QUANTITY	TOTALINE PART NO.
1 Quart	P903-2325
1 Gallon	P903-2301
5 Gallon	P903-2305

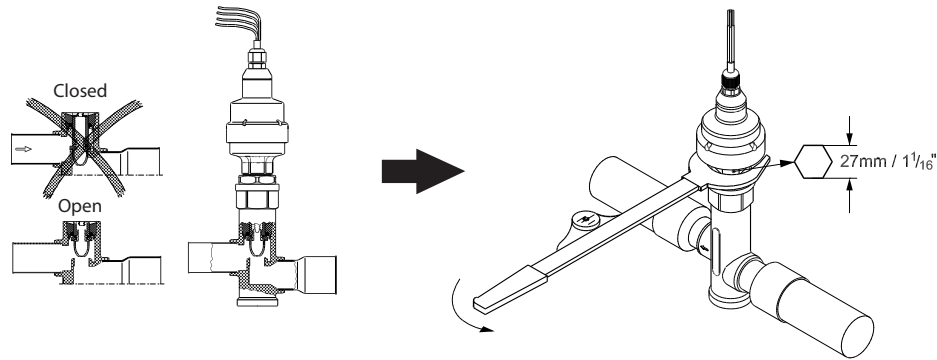
If unsure if there is low oil charge in the system, follow the steps below:

1. If the unit shuts off repeatedly from a low oil level alert it may be an indication of inadequate oil charge; however, it could also indicate that the oil is not being reclaimed from the low-side of the system.
2. Begin running the unit at full load for 1½ hours. Use the manual Test Mode feature of Service Test if the unit does not normally run at full load.

NOTE: An adequate load must be available.

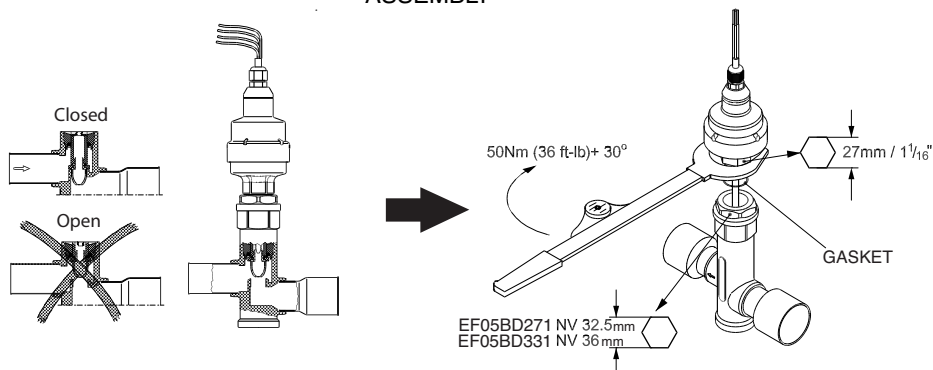
3. After running the unit for 1½ hours at full load, allow the unit to restart and run normally. If low oil alarms persist, continue with the following steps.
4. Close the liquid line service valve and place a pressure gage on top of the cooler or suction line service port. Enable the Service Test feature and turn the Enable/Off/Remote switch to the enable position. Start the desired circuit by turning it on under the TEST function: **CPA** for compressor **A**, **CPB** for compressor **B**, or **CPC** for compressor **C**.

**DISASSEMBLY**



NOTE: Open valve in Quick Test sub-mode before disassembling.

**ASSEMBLY**



**NOTES:**

1. Push down on valve piston to close valve before assembling.
2. After valve is assembled close valve in Quick Test sub-mode or cycle power before opening service valve.

**Fig. 48 — Disassembly and Assembly of EXV Motor**

- When the compressor starts successfully, observe the cooler pressure. When the pressure reads 10 psig (68.9 kPa), turn the Emergency Switch (SW2) to the OFF position. The compressor should stop.
- Open the liquid line service valve and allow the unit to restart normally. If low oil level alarms persist, continue with the following steps.
- If none of the previous steps were successful, the unit is low on oil charge. Add oil to the oil separator using the 1/4 in. access fitting that the discharge pressure transducer is mounted to.

**NOTE:** To facilitate the oil charging process, ensure that the unit is not running when adding oil. The system is under pressure even when the unit is not running, so it is necessary to use a suitable pump to add oil to the system. Using a suitable pump, add 1/2 gal (1.9 l) of oil to the system. Continue adding oil in 1/2 gal (1.9 l) increments until the problem is resolved, up to a maximum of 1.5 gal (5.7 l). If it is necessary to add factory oil charge levels to the system contact your local Carrier representative.

**Oil Filter Maintenance** — Each circuit has one oil filter located externally to the compressor. Oil line pressure drop is monitored by the control. Oil line pressure drop is calculated by subtracting oil pressure (OP) from discharge pressure (DP). If the oil line pressure drop exceeds 30 psi (206.8 kPa) for 5 minutes the control will generate a High Oil Filter Pressure Drop alert. The High Oil Filter Pressure Drop alert will not shut down the compressor, but instead indicates that the oil filter is dirty. If oil pressure line losses exceed 50 psi (344.7 kPa) then the control will shut down the circuit on Maximum Oil Filter Differential Pressure Failure.

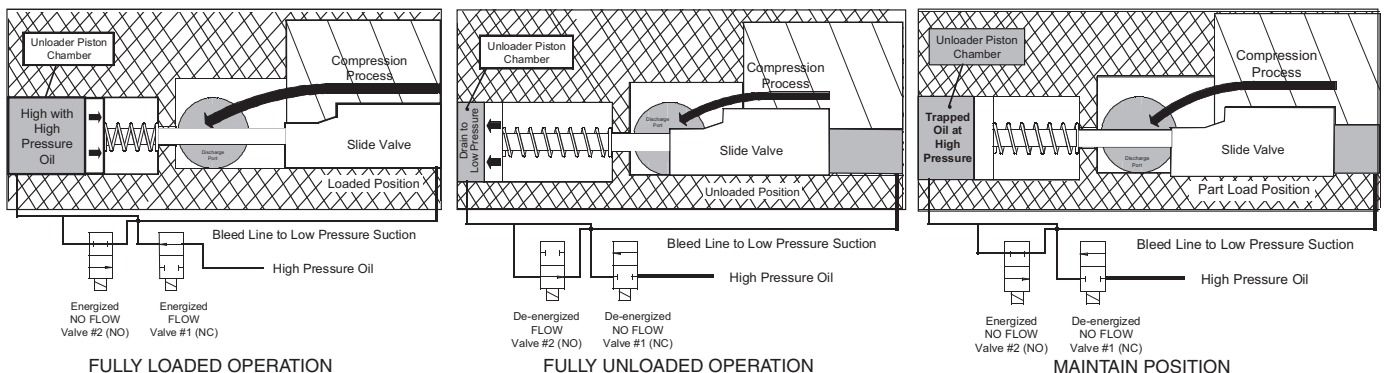
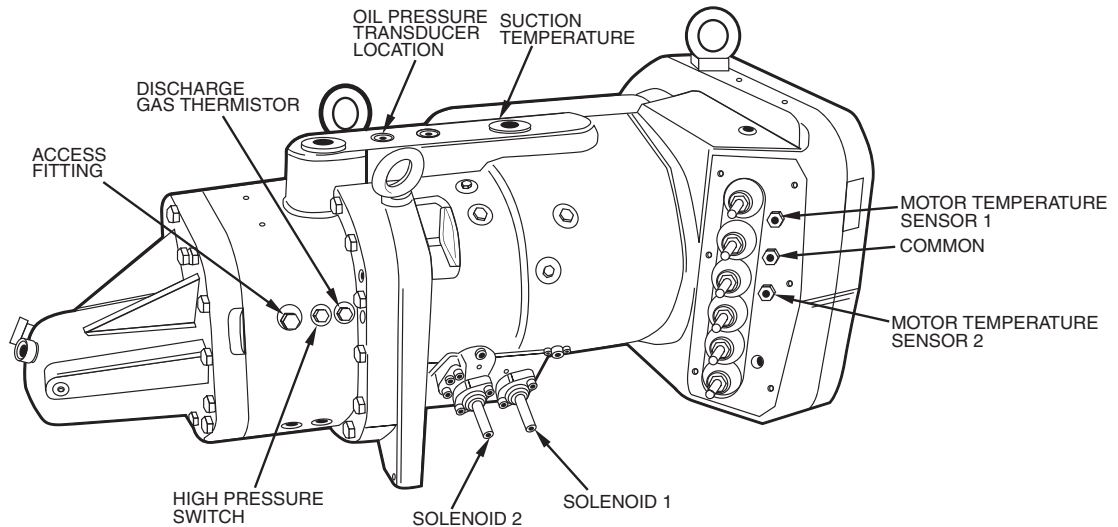
**CAUTION**

Compressor oil is pressurized. Use proper safety precautions when relieving pressure.

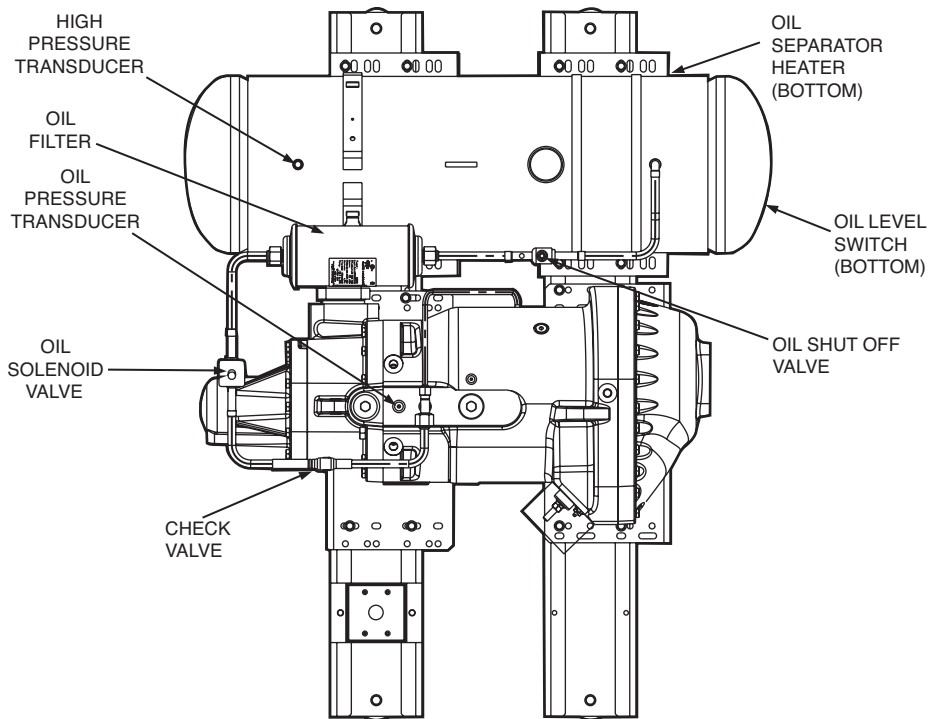
**Replacing the Oil Filter** — Close the oil line ball valve located in front of the oil filter. Connect a charging hose to the 1/4-in. access fitting port located downstream of the valve and bleed off oil trapped between the service valve and the oil solenoid valve. A quart of oil is typically what is removed during this process. Remove the charging hose. Unscrew the nuts from both ends of the oil filter and remove the oil filter. Remove the protective caps from the new oil filter and install, being careful not to lose or damage the new O-ring located on the new oil filter. Draw a vacuum at the Schrader port. Remove the charging hose and open the oil line ball valve. Check both fittings for leaks.

### Flooded Cooler Units

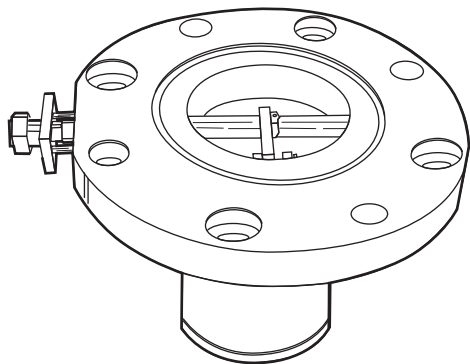
**FLOODED COOLER UNIT SUCTION SERVICE VALVE** — The suction service valve is a factory-installed option for 30XA units. It is located in the suction outlet of the cooler. The suction service valve is bolted between the cooler outlet and the suction flange piping. The suction service valve shaft has a locking device located on the shaft to lock the valve in either a fully open position or a fully closed position. The locking device must be pulled out prior to moving the valve handle to a fully open or a fully closed position. See Fig. 51A and 51B.



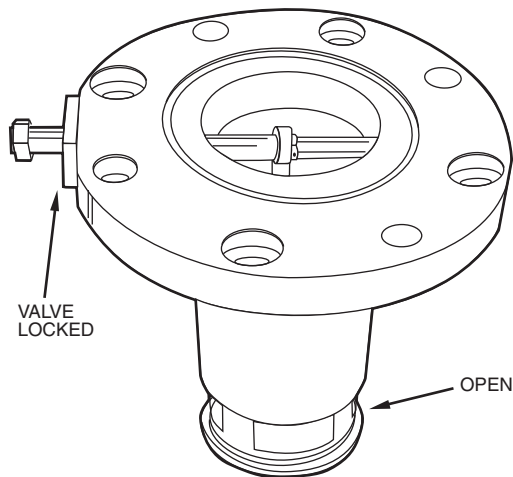
**Fig. 49 — Typical 06T Compressor (All Units)**



**Fig. 50 — Typical Oil System (All Units)**



**Fig. 51A — Suction Service Valve Locking Device, Closed and Unlocked (Flooded Cooler Units)**



**Fig. 51B — Suction Service Valve Locking Device, Open and Locked (Flooded Cooler Units)**

**FLOODED COOLER FREEZE PROTECTION** — All coolers are equipped with cooler heaters and are controlled by the Main Base Board. The control logic uses the unit status, outdoor air temperature, and the saturated suction temperatures for all circuits to decide if the cooler heater should be energized. The cooler heaters can only be energized when the state of the unit is OFF. The cooler heaters will be energized if the outdoor-air temperature is less than the Cooler Heater Set Point and the lowest circuit Saturated Suction Temperature is less than the heater set point plus 6° F (3.3° C). See Table 51. The cooler heater set point = freeze point + Cooler Heater DT Setp (**Cooler Heater Delta Spt, HTR**). If the entering or leaving water temperature is less than the Heater Set Point and the outdoor air temperature is less than the Heater Set Point -2° F (1.1° C), then the heater will be turned on.

If the Entering or Leaving Water Temperature is less than the Brine Freeze Setpoint (**Brine Freeze Setpoint, LOSP**) +1.0° F (0.5° C), then the heater will be turned on along with the pump.

The entire cooler is covered with closed-cell insulation applied over the heater. The heater plus insulation protects cooler against low ambient temperature freeze-up to 0° F (-17.8 C).

**IMPORTANT:** If unit is installed in an area where ambient temperatures fall below 32 F (0° C), a suitable corrosion-inhibited antifreeze solution or cooler heater must be used in the chilled water circuit.

**FLOODED COOLER LOW FLUID TEMPERATURE** — Main Base Board is programmed to shut chiller down if leaving fluid temperature drops below 34 F (1.1 C) for cooler fluid type water or below Brine Freeze Setpoint (**Brine Freeze Setpoint, LOSP**) for cooler fluid type brine. The unit will shut down without a pumpout. When fluid temperature rises to 6° F (3.3° C) above the leaving fluid set point, safety resets and chiller restarts. Reset is automatic as long as this is the first occurrence.



**Table 51 — Cooler Heater Operation Examples for Flooded Coolers**

OAT F (C)	UNIT STATUS	BRINE FREEZE POINT F (C)	COOLER DELTA T F (C)	COOLER HEATER SETPOINT F (C)	SSTA F (C)	SSTB F (C)	SSTC F (C)	COOLER HEATER STATUS	COMMENTS
50 (10)	OFF	36 (2.2)	6 (3.3)	42 (5.6)	N/A	N/A	N/A	OFF	OAT >42 F (5.6 C)
40 (4.4)	OFF	36 (2.2)	6 (3.3)	42 (5.6)	41 (5)	N/A	N/A	ON	SSTA <42 F (5.6 C)
40 (4.4)	OFF	15 (-9.4)	6 (3.3)	21 (-6.1)	41 (5)	N/A	N/A	OFF	SSTA >21 F (-6.1 C)
40 (4.4)	OFF	36 (2.2)	6 (3.3)	42 (5.6)	52.1 (11.2)	52.1 (11.2)	52.1 (11.2)	OFF	All SST Temperatures >52 F (11.2 C)
40 (4.4)	ON	36 (2.2)	6 (3.3)	42 (5.6)	N/A	N/A	N/A	OFF	Unit Status ON

**LEGEND**

- N/A — Not Applicable
- OAT — Outdoor-Air Temperature
- SSTA — Saturated Suction Temperature, Circuit A
- SSTB — Saturated Suction Temperature, Circuit B
- SSTC — Saturated Suction Temperature, Circuit C

**FLOODED COOLER LOSS OF FLUID FLOW PROTECTION** — All 30XA machines include an integral flow switch that protects the cooler against loss of cooler flow.

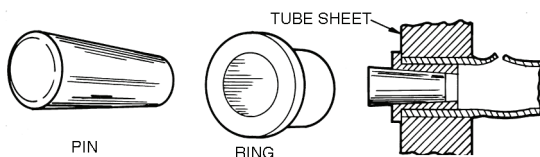
**FLOODED COOLER TUBE PLUGGING** — A leaky tube can be plugged until retubing can be done. The number of tubes plugged determines how soon the cooler *must* be retubed. All tubes in the cooler may be removed. Loss of unit capacity and efficiency as well as increased pump power will result from plugging tubes. Failed tubes should be replaced as soon as possible. Up to 10% of the total number of tubes can be plugged before retubing is necessary. Figure 52 shows an Elliott tube plug and a cross-sectional view of a plug in place. See Tables 52 and 53 for plug components. If the tube failure occurs in both circuits using tube plugs will not correct the problem. Contact your local Carrier representative for assistance.

**CAUTION**

Use extreme care when installing plugs to prevent damage to the tube sheet section between the holes.

**FLOODED COOLER RETUBING** — When retubing is required, obtain service of qualified personnel experienced in boiler maintenance and repair. Most standard procedures can be followed when retubing the coolers. An 8% crush is recommended when rolling replacement tubes into the tubesheet.

Place one drop of Loctite No. 675 or equivalent on top of tube prior to rolling. This material is intended to “wick” into the area of the tube that is not rolled into the tube sheet, and prevent fluid from accumulating between the tube and the tube sheet. New tubes must also be rolled into the center tubesheet to prevent circuit to circuit leaks.



**Fig. 52 — Elliott Tube Plug**

**Table 52 — Plug Component Parts (Flooded Cooler Units Only)**

COMPONENT	PART NUMBER
<b>For Tubes</b>	
Brass Pin	853103-1*
Brass Ring	853002-640 or 657* (measure tube before ordering)
<b>For Holes without tubes</b>	
Brass Pin	853103-1A
Brass Ring	85102-738
Loctite	No. 675 †
Locquic	“N”†
Roller Extension	S82-112/11

\*Order directly from Elliot Tube Company, Dayton, OH or RCD.  
†Can be obtained locally.

**Table 53 — Flooded Cooler Tube Components**

COMPONENT	SIZE	
	in.	mm
Tube sheet hole diameter	0.756	19.20
Tube OD	0.750	19.05
Tube ID after rolling (includes expansion due to clearance.)	0.650 to 0.667	16.51 to 16.94

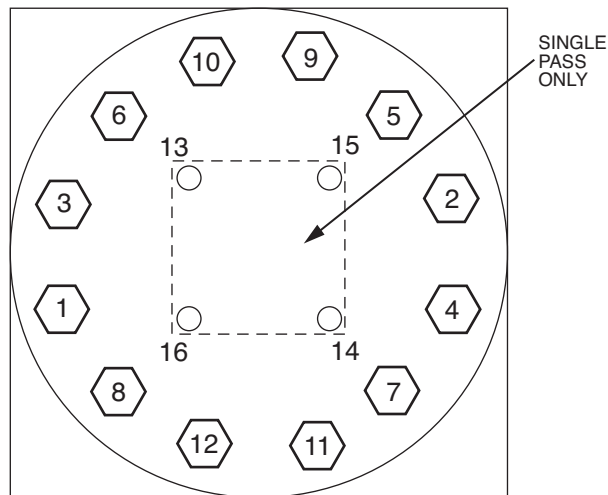
NOTE: Tubes replaced along heat exchanger head partitions must be flush with tube sheet (both ends).

**FLOODED COOLER TIGHTENING COOLER HEAD BOLTS**

**Preparation** — When reassembling cooler heads, always check the condition of the O-rings first. The O-ring should be replaced if there is visible signs of deterioration, cuts or damage. Apply a thin film of grease to the O-ring before installation. This will aid in holding the O-ring in the groove while the head is installed. Torque all bolts to the following specification and in sequence:

3/4-in. Diameter Perimeter Bolts (Grade 5) . . . 200 to 225 ft-lb (271 to 305 N-m)

1. Install all bolts finger tight.
2. Bolt tightening sequence is outlined in Fig. 53. Follow the numbering or lettering sequence so that pressure is evenly applied to O-ring.
3. Apply torque in one-third steps until required torque is reached. Load *all* bolts to each one-third step before proceeding to next one-third step.
4. No less than one hour later, retighten all bolts to required torque values.
5. After refrigerant is restored to system, check for refrigerant leaks using recommended industry practices.
6. Replace cooler insulation.



**Fig. 53 — Flooded Cooler Unit Head Recommended Bolt Torque Sequence**

**FLOODED COOLER INSPECTING/CLEANING HEAT EXCHANGERS** — Inspect and clean cooler tubes at the end of the first operating season. Because these tubes have internal ridges, a rotary-type tube cleaning system is necessary to fully clean the tubes. Tube condition in the cooler will determine the scheduled frequency for cleaning, and will indicate whether water treatment is adequate in the chilled water/brine circuit. Inspect the entering and leaving water thermistor wells for signs of corrosion or scale. Replace the well if corroded or remove any scale if found.

**⚠ CAUTION**

Hard scale may require chemical treatment for its prevention or removal. Consult a water treatment specialist for proper treatment procedures.

**FLOODED COOLER WATER TREATMENT** — Untreated or improperly treated water may result in corrosion, scaling, erosion or algae. The services of a qualified water treatment specialist should be obtained to develop and monitor a treatment program.

**⚠ CAUTION**

Water must be within design flow limits, clean and treated to ensure proper machine performance and reduce the potential of tubing damage due to corrosion, scaling, and algae. Carrier assumes no responsibility for cooler damage resulting from untreated or improperly treated water.

**DX Cooler Units**

**DX COOLER SUCTION SERVICE VALVE** — The suction service valve is a factory-installed option for 30XA units. It is

located in the suction line for each circuit. The suction service valve is either a ball valve type valve or a butterfly type valve.

**DX COOLER FREEZE PROTECTION** — Coolers can be ordered with heaters installed in the factory. If equipped, the main base board based on the outdoor-air temperature and the entering and leaving water thermistors controls the cooler heaters. The Heater Set Point is the sum of the freeze point and Cooler Heater DT Setp (**Configuration** → **SERV** → **HTR**).

If the entering or leaving water temperature is less than the Heater Set Point and the outdoor air temperature is less than the Heater Set Point - 2° F (1.1° C), then the heater will be turned on.

If the Entering or Leaving Water Temperature is less than the Brine Freeze Setpoint (**Configuration** → **SERV** → **LOSP**) + 1.0° F (0.5° C), then the heater will be turned on along with the pump.

Entire cooler is covered with closed-cell insulation applied over the heater. Heater plus insulation protect cooler against low ambient temperature freeze-up to -20 F (-28 C).

**IMPORTANT:** If unit is installed in an area where ambient temperatures fall below 32 F (0° C), it is recommended that a suitable corrosion-inhibited anti-freeze solution be used in chilled water circuit.

**DX COOLER LIQUID FLUID TEMPERATURE** — Main Base Board is programmed to shut chiller down if leaving fluid temperature drops below 34 F (1.1 C) for cooler fluid type water or below Brine Freeze Setpoint (Brine Freeze Setpoint, LOSP) for cooler fluid type brine. The unit will shut down without a pumpout. When fluid temperature rises to 6 F (3.3 C) above the leaving fluid set point, safety resets and chiller restarts. Reset to automatic as long as this is the first occurrence.

**DX COOLER LOSS OF FLUID FLOW PROTECTION** — All 30XA machines include an integral flow switch that protects the cooler against loss of cooler flow.

**DX COOLER TUBE PLUGGING** — A leaky tube can be plugged until retubing can be done. The number of tubes plugged determines how soon the cooler must be retubed. If several tubes require plugging, check with a local Carrier representative to find out how the number and location of tubes can affect unit capacity. Fig. 54 shows an Elliott tube plug and a cross-sectional view of a plug in place. See Tables 54 and 55 for plug components.

**⚠ CAUTION**

Use extreme care when installing plugs to prevent damage to the tube sheet section between the holes.

**Table 54 — DX Cooler Unit Plug Component Part Numbers**

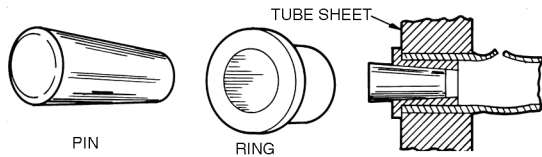
COMPONENTS FOR PLUGGING	PART NUMBER
<b>For Tubes</b>	
Brass Pin	853103-312*
Brass Ring	853002-322*
<b>For Holes without tubes</b>	
Brass Pin	853103-375
Brass Ring	853002-377
Loctite	No. 675 †
Locquic	"N" †

\*Order directly from Elliot Tube Company, Dayton, OH or RCD.  
†Can be obtained locally.

**Table 55 — DX Cooler Unit Plug Component Dimensions**

PLUG COMPONENT	SIZE	
	in.	mm
Tube sheet hole diameter	0.377-0.382	9.58-9.70
Tube OD	0.373-0.377	9.47-9.58
Tube ID after rolling (includes expansion due to clearance.)	0.328	8.33

NOTE: Tubes next to gasket webs must be flush with tube sheet (both ends).



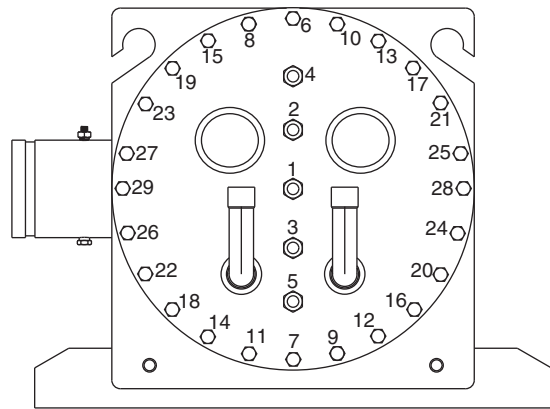
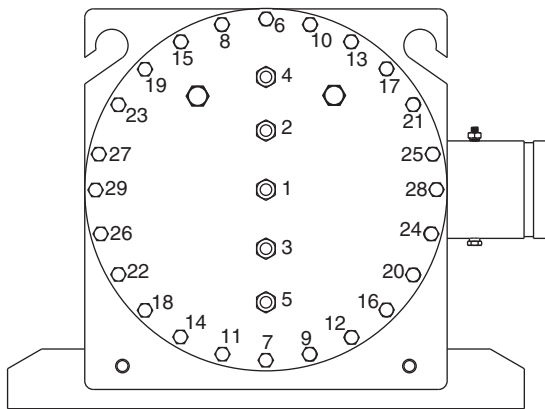
**Fig. 54 — Elliott Tube Plug**

For the 30XA142,162,182,202,222,242,262,282,302,327, 352 DX coolers, the pass partition has a perforated distribution plate in the inlet pass to more uniformly distribute the refrigerant as it enters the tubes of the cooler. The perforated distribution plate is on the tubesheet side of the pass partition. A tube plug will interfere with the installation of pass partition. The tube plug must be flush with the tube sheet to prevent this interference. The pass partition is symmetrical, meaning the partition plate can be rotated 180 degrees, however, the performance of the machine will be affected if the pass partition is installed incorrectly.

**DX COOLER RETUBING** — When retubing is required, obtain service of qualified personnel experienced in boiler maintenance and repair. Most standard procedures can be followed when retubing the coolers. An 8% crush is recommended when rolling replacement tubes into the tubesheet.

The following Elliott Co. tube rolling tools are required:

- Expander Assembly
- Cage
- Mandrel
- Rolls



**Fig. 55 — Bolt Tightening Sequence, 30XA082,092,102,122**

Place one drop of Loctite No. 675 or equivalent on top of tube prior to rolling. This material is intended to “wick” into the area of the tube that is not rolled into the tube sheet, and prevent fluid from accumulating between the tube and the tube sheet.

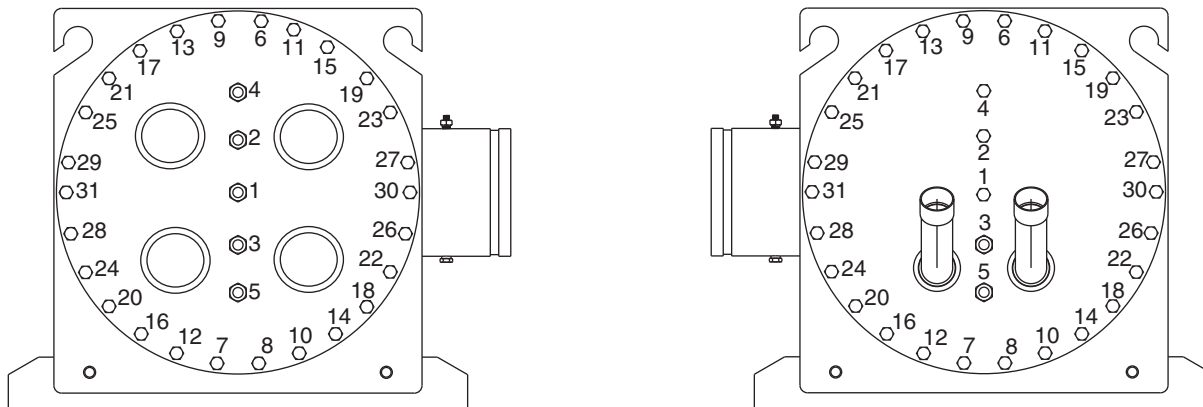
**DX COOLER TIGHTENING COOLER HEAD BOLTS (Fig. 55-58)**

**Gasket Preparation** — When reassembling cooler heads, always use new gaskets. Gaskets are neoprene-based and are brushed with a light film of compressor oil. *Do not soak gasket or gasket deterioration will result.* Use new gaskets within 30 minutes to prevent deterioration. Reassemble cooler nozzle end or plain end cover of the cooler with the gaskets. Torque all cooler bolts to the following specification and sequence:

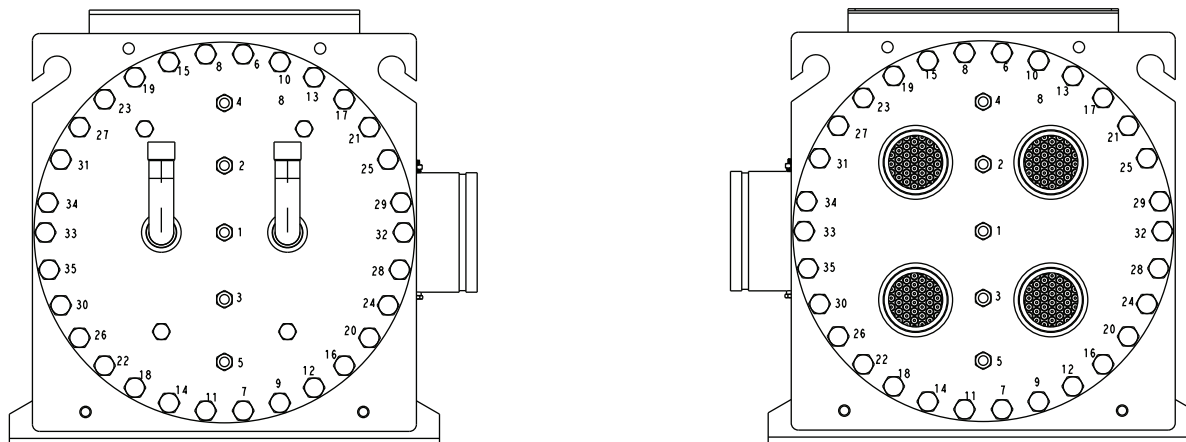
- $\frac{5}{8}$ -in. Diameter Perimeter Bolts (Grade 5) . . . 150 to 170 ft-lb (201 to 228 N-m)
- $\frac{1}{2}$ -in. Diameter Flange Bolts (Grade 5) . . . . . 70 to 90 ft-lb (94 to 121 N-m)
- $\frac{1}{2}$ -in. Diameter Center Stud (Grade 5) . . . . . 70 to 90 ft-lb (94 to 121 N-m)

1. Install all bolts finger tight, except for the suction flange bolts. Installing these flanges will interfere with tightening the center stud nuts.
2. Bolt tightening sequence is outlined in Fig. 55-58. Follow the numbering or lettering sequence so that pressure is evenly applied to gasket.
3. Apply torque in one-third steps until required torque is reached. Load *all* bolts to each one-third step before proceeding to next one-third step.
4. No less than one hour later, retighten all bolts to required torque values.
5. After refrigerant is restored to system, check for refrigerant leaks using recommended industry practices.
6. Replace cooler insulation.

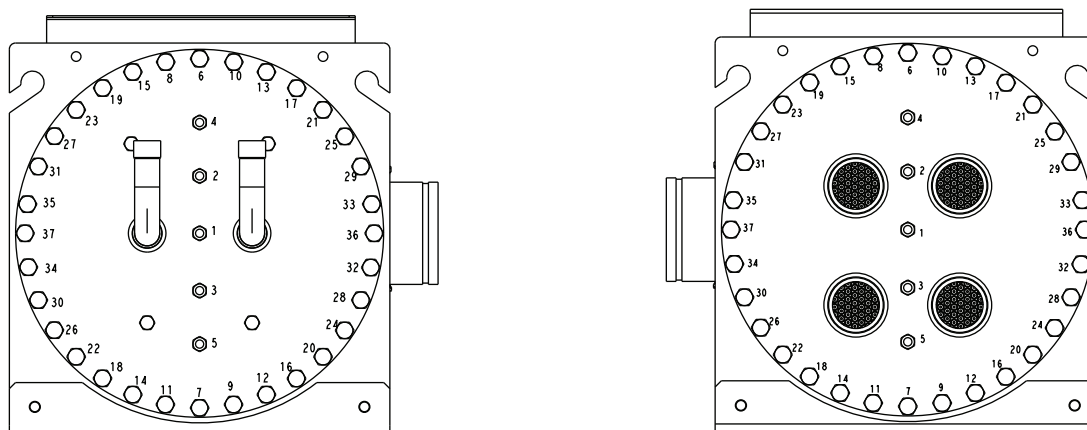




**Fig. 56 — Bolt Tightening Sequence, 30XA142,162,182,202**



**Fig. 57 — Bolt Tightening Sequence, 30XA222, 242, 262, 282**



**Fig. 58 — Bolt Tightening Sequence, 30XA302, 327, 352**

**DX COOLER CHILLED WATER FLOW SWITCH** — A factory-installed flow switch is installed in the entering water nozzle for all machines. See Fig. 59 and 60. This is a thermal-dispersion flow switch. Figure 59 shows typical installation. If nuisance trips of the sensor are occurring, follow the steps below to correct:

1. Check to confirm that all strainers are clean, valves are open and pumps are running. For the case of variable frequency drive (VFD) controlled pumps, ensure the minimum speed setting has not been changed.
2. Measure the pressure drop across the cooler. Use the cooler pressure drop curves on pages 62-67 to calculate the flow and compare this to system requirements.

### **DX Cooler and Flooded Cooler Units**

**PREPARATION FOR WINTER SHUTDOWN** — If the unit is not operational during the winter months, at the end of cooling season complete the following steps.

#### **CAUTION**

Failure to remove power before draining heater equipped coolers and hydronic packages can result in heater tape and insulation damage.

1. If the unit has optional heater tapes on the cooler and the cooler will not be drained, do not shut off power disconnect during off-season shutdown. If the unit has optional

heater tapes on the cooler and the cooler is drained, open the circuit breaker for the heater, CB-13 or shut off power during off-season shutdown.

2. Draining the fluid from the system is highly recommended. If the unit is equipped with a hydronic package, there are additional drains in the pump housing and strainer that must be opened to allow for all of the water to drain.
3. Isolate the cooler from the rest of the system with water shutoff valves.
4. Replace the drain plug and completely fill the cooler with a mixture of water and a suitable corrosion-inhibited antifreeze solution such as propylene glycol. The concentration should be adequate to provide freeze protection to 15° F (8.3° C) below the expected low ambient temperature conditions. Antifreeze can be added through the vent on top of the cooler. If the unit has a hydronic pump package, the pump must be treated in the same manner.
5. Leave the cooler filled with the antifreeze solution for the winter, or drain if desired. Be sure to deenergize heaters (if installed) as explained in Step 1 to prevent damage. Use an approved method of disposal when removing antifreeze solution.



Fig. 59 — Chilled Water Flow Switch

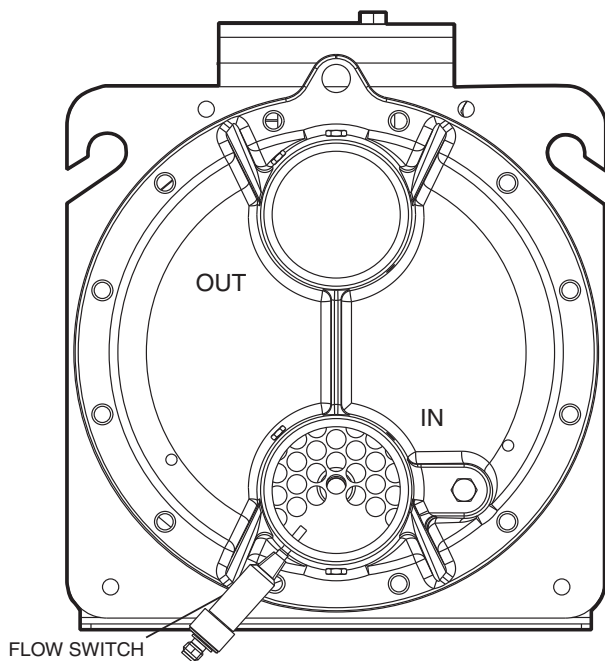


Fig. 60 — Flow Switch

At the beginning of the next cooling season, be sure that there is refrigerant pressure on each circuit before refilling cooler, add recommended inhibitor, and reset the CB-HT (circuit breaker heater) (if opened) or restore power.

### Microchannel Heat Exchanger (MCHX) Condenser Coil Maintenance and Cleaning Recommendations

— Routine cleaning of coil surfaces is essential to maintain proper operation of the unit. Elimination of contamination and removal of harmful residues will greatly increase the life of the coil and extend the life of the unit. The following steps should be taken to clean MCHX condenser coils:

#### CAUTION

Do not apply any chemical cleaners to MCHX condenser coils. These cleaners can accelerate corrosion and damage the coil.

1. Remove any foreign objects or debris attached to the coil face or trapped within the mounting frame and brackets.
2. Put on personal protective equipment including safety glasses and/or face shield, waterproof clothing and gloves. It is recommended to use full coverage clothing.
3. Start high pressure water sprayer and purge any soap or industrial cleaners from sprayer before cleaning condenser coils. Only clean potable water is authorized for cleaning condenser coils.
4. Clean condenser face by spraying the coil steady and uniformly from top to bottom while directing the spray straight toward the coil. Do not exceed 900 psig (6205 kPa) or 30 degree angle. The nozzle must be at least 12 in. (304.8 mm) from the coil face. Reduce pressure and use caution to prevent damage to air centers.

#### CAUTION

Excessive water pressure will fracture the braze between air centers and refrigerant tubes.

### RTPF (Round Tube Plate Fin) Condenser Coil Maintenance and Cleaning Recommendations

— Routine cleaning of coil surfaces is essential to maintain proper operation of the unit. Elimination of contamination and removal of harmful residues will greatly increase the life of the coil and extend the life of the unit. The following maintenance and cleaning procedures are recommended as part of the routine maintenance activities to extend the life of the coil.

**REMOVE SURFACE LOADED FIBERS** — Surface loaded fibers or dirt should be removed with a vacuum cleaner. If a vacuum cleaner is not available, a soft non-metallic bristle brush may be used. In either case, the tool should be applied in the direction of the fins. Coil surfaces can be easily damaged (fin edges can be easily bent over and damage to the coating of a protected coil) if the tool is applied across the fins.

**NOTE:** Use of a water stream, such as a garden hose, against a surface loaded coil will drive the fibers and dirt into the coil. This will make cleaning efforts more difficult. Surface loaded fibers must be completely removed prior to using low velocity clean water rinse.

**PERIODIC CLEAN WATER RINSE** — A periodic clean water rinse is very beneficial for coils that are applied in coastal or industrial environments. However, it is very important that the water rinse is made with very low velocity water stream to avoid damaging the fin edges. Monthly cleaning as described below is recommended.

**ROUTINE CLEANING FOR RTPF COIL SURFACE** — Monthly cleaning with Totaline® environmentally sound coil cleaner is essential to extend the life of coils. This cleaner is available from Carrier Replacement Parts division as part number P902-0301 for a one gallon container, and part number P902-0305 for a five gallon container. It is recommended that all coils, including the standard copper tube aluminum fin, pre-coated fin, copper fin, or e-coated coils be cleaned with the Totaline environmentally sound coil cleaner as described below. Coil cleaning should be part of the unit's regularly scheduled maintenance procedures to ensure long life of the coil. Failure to clean the coils may result in reduced durability in the environment. Avoid the use of:

- coil brighteners
- acid cleaning prior to painting
- high pressure washers
- poor quality water for cleaning

Totaline environmentally sound coil cleaner is non-flammable, hypoallergenic, nonbacterial, and a USDA accepted biodegradable agent that will not harm the coil or surrounding components such as electrical wiring, painted metal surfaces, or insulation. Use of non-recommended coil cleaners is strongly discouraged since coil and unit durability could be affected.

Totaline Environmentally Sound Coil Cleaner Application Equipment

- 2½ gallon garden sprayer
- Water rinse with low velocity spray nozzle

<b>⚠ CAUTION</b>
Harsh chemicals, household bleach or acid or basic cleaners should not be used to clean outdoor or indoor coils of any kind. These cleaners can be very difficult to rinse out of the coil and can accelerate corrosion at the fin/tube interface where dissimilar materials are in contact. If there is dirt below the surface of the coil, use the Totaline environmentally sound coil cleaner as described above.

<b>⚠ CAUTION</b>
High velocity water from a pressure washer, garden hose, or compressed air should never be used to clean a coil. The force of the water or air jet will bend the fin edges and increase airside pressure drop. Reduced unit performance or nuisance unit shutdown may occur.

Totaline Environmentally Sound Coil Cleaner Application Instructions

1. Proper eye protection such as safety glasses is recommended during mixing and application.
2. Remove all surface loaded fibers and dirt with a vacuum cleaner as described above.
3. Thoroughly wet finned surfaces with clean water and a low velocity garden hose, being careful not to bend fins.
4. Mix Totaline environmentally sound coil cleaner in a 2½ gallon garden sprayer according to the instructions included with the cleaner. The optimum solution temperature is 100 F.

NOTE: Do **NOT** USE water in excess of 130 F (54.4 C), as the enzymatic activity will be destroyed.

5. Thoroughly apply Totaline environmentally sound coil cleaner solution to all coil surfaces including finned area, tube sheets and coil headers.
6. Hold garden sprayer nozzle close to finned areas and apply cleaner with a vertical, up-and-down motion. Avoid spraying in horizontal pattern to minimize potential for fin damage.

7. Ensure cleaner thoroughly penetrates deep into finned areas.
8. Interior and exterior finned areas must be thoroughly cleaned.
9. Finned surfaces should remain wet with cleaning solution for 10 minutes.
10. Ensure surfaces are not allowed to dry before rinsing. Reapplying cleaner as needed to ensure 10-minute saturation is achieved.
11. Thoroughly rinse all surfaces with low velocity clean water using downward rinsing motion of water spray nozzle. Protect fins from damage from the spray nozzle.

**Condenser Fans** — A formed metal mount bolted to fan deck supports each fan and motor assembly. A shroud and a wire guard provide protection from the rotating fan. See Fig. 61. The exposed end of the fan motor shaft is protected from weather by grease. If fan motor must be removed for service or replacement, be sure to regrease fan shaft and reinstall fan guard. The fan motor has a step in the motor shaft. For proper performance, fan should be positioned such that it is securely seated on this step. Tighten the bolt to 15 ft lb ± 2.0 (20.34 Nm ± 2.7 Nm) .

**Refrigerant Circuit**

**LEAK TESTING** — Units are shipped with complete operating charge of refrigerant R-134a (see Physical Data tables supplied in the 30XA installation instructions) and should be under sufficient pressure to conduct a leak test. If there is no pressure in the system, introduce enough nitrogen to search for the leak. Repair the leak using good refrigeration practices. After leaks are repaired, system must be evacuated and dehydrated.

**REFRIGERANT CHARGE** — Refer to Physical Data tables supplied in the 30XA installation instructions). Immediately ahead of filter drier in each circuit is a factory-installed liquid line service valve. Each valve has a ¼-in. access connection for charging liquid refrigerant.

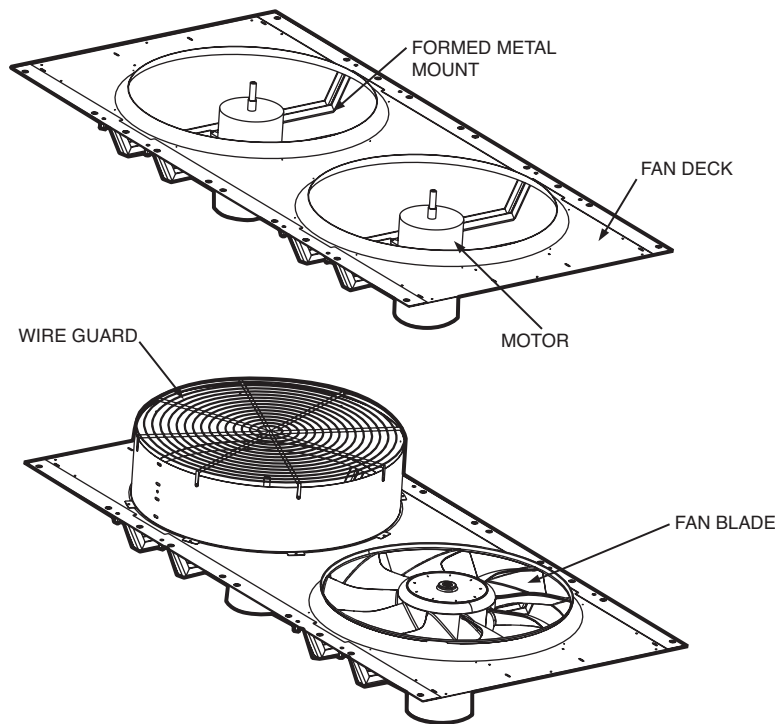
**Charging with Unit Off and Evacuated** — Close liquid line service valve before charging. Weigh in charge shown on unit nameplate. Open liquid line service valve; start unit and allow it to run several minutes fully loaded. Check for a clear sight glass. Be sure clear condition is liquid and not vapor.

**Charging with Unit Running** — If charge is to be added while unit is operating, all condenser fans and compressors must be operating. It may be necessary to block condenser coils at low ambient temperatures to raise condensing pressure to approximately 198 psig (1365 kPa) to turn all condenser fans on. Do not totally block a coil to do this. Partially block all coils in uniform pattern. Charge each circuit until sight glass shows clear liquid, and has a liquid line temperature of 103 F (39 C) for 30XA080-352 units and 108 F (42 C) for 30XA400-500 units.

Add 3 to 5 lb (1.36 to 2.27 kg) depending on unit size of liquid charge into the fitting located on the tube entering the cooler. This fitting is located between the electronic expansion valve (EXV) and the cooler.

Allow the system to stabilize and then recheck the liquid temperature. If needed, add additional liquid charge, 3 to 5 lb at a time, allowing the system to stabilize between each charge addition. Slowly add charge as the sight glass begins to clear to avoid overcharging.

<b>IMPORTANT:</b> When adjusting refrigerant charge, circulate fluid through cooler continuously to prevent freezing and possible damage to the cooler. Do not overcharge, and never charge liquid into the low-pressure side of system.
--



**Fig. 61 — Fan Mounting**

**Safety Devices** — The 30XA chillers contain many safety devices and protection logic built into the electronic control. Following is a description of the major safeties.

**COMPRESSOR PROTECTION**

**Motor Overload** — The compressor protection modules (CPM) protect each compressor against overcurrent. Do not bypass the current transformers or make any changes to the factory-installed and configured headers. The configuration of these headers defines the Must Trip Amps (MTA) at which the CPM will turn the compressors off. Determine the cause for trouble and correct the problem before resetting the CPM. See Appendix D for MTA settings and configuration headers.

Each CPM board also reads the status of each compressor's high-pressure switch. All compressors have factory-installed high-pressure switches. See Table 56.

**Table 56 — High-Pressure Switch Settings**

UNIT	SWITCH SETTING	
	psig	kPa
30XA	304.5 +7.25, -14.5	2099 +50, -100

If the switch opens during operation, the compressor will be shut down. The CPM will reset automatically when the switch closes, however, a manual reset of the control is required to restart the compressor.

**OIL SEPARATOR HEATERS** — Each oil separator circuit has a heater mounted on the underside of the vessel. The heater is deenergized anytime the compressor is on. If the compressor is off and outdoor-air temperature (OAT) is greater than 100 F (37.8 C) the heater is deenergized. The heater will also be deenergized if OAT - SST >32 F (17.8° C) and the OAT - LWT > 32 F (17.8° C).

**COOLER PROTECTION**

**Low Water Temperature** — Microprocessor is programmed to shut the chiller down if the leaving fluid temperature drops below 34 F (1.1 C) for water or more than 8° F (4.4° C) below set point for Fluid Type = brine. When the fluid temperature rises 6° F (3.3° C) above the leaving fluid set point, the safety resets and the chiller restarts. Reset is automatic as long as this is the first occurrence of the day.

**IMPORTANT:** If unit is installed in an area where ambient temperatures fall below 32 F (0° C), a suitable corrosion-inhibited antifreeze solution or cooler heater must be used in the chilled water circuit.

**Relief Devices** — Fusible plugs are located in each circuit between the condenser and the liquid line shutoff valve.

**PRESSURE RELIEF VALVES** — Valves are installed in each circuit and are located on the coolers and oil separators. These valves are designed to relieve if an abnormal pressure condition arises. Relief valves on all coolers relieve at 220 psi (1517 kPa). Relief valves on oil separators relieve at 350 psi (2413 kPa). These valves should not be capped. If a valve relieves, it should be replaced. If the valve is not replaced, it may relieve at a lower pressure, or leak due to trapped dirt from the system which may prevent resealing.

See Table 57. Some local building codes require that relieved gases be exhausted to a specific location. This connection allows conformance to this requirement.

**Table 57 — Relief Valve Connection Specs**

LOCATION	CONNECTION SIZES
Oil Separator	3/8 SAE Flare
DX Cooler Option	5/8 SAE Flare
Flooded Cooler Option	3/4 in. NPT Female

**MAINTENANCE**

**Recommended Maintenance Schedule** — The following are only recommended guidelines. Jobsite conditions may dictate that maintenance schedule is performed more often than recommended.

Routine:

For machines with e-coat condenser coils:

- Check condenser coils for debris; clean as necessary with Carrier approved coil cleaner.
- Periodic clean water rinse, especially in coastal and industrial applications.



Every month:

- Check condenser coils for debris; clean as necessary with Carrier approved coil cleaner.
- Check moisture indicating sight glass for possible refrigerant loss and presence of moisture.

Every 3 months (for all machines):

- Check refrigerant charge.
- Check all refrigerant joints and valves for refrigerant leaks; repair as necessary.
- Check chilled water flow switch operation.
- Check all condenser fans for proper operation.
- Check oil filter pressure drop.
- Check oil separator heater operation.
- Inspect pump seal, if equipped with a hydronic pump package.

Every 12 months (for all machines):

- Check all electrical connections; tighten as necessary.
- Inspect all contactors and relays; replace as necessary.
- Check accuracy of thermistors; replace if greater than  $\pm 2^\circ\text{F}$  ( $1.2^\circ\text{C}$ ) variance from calibrated thermometer.
- Check accuracy of transducers; replace if greater than  $\pm 5\text{ psi}$  ( $34.47\text{ kPa}$ ) variance.
- Check to be sure that the proper concentration of antifreeze is present in the chilled water loop, if applicable.
- Verify that the chilled water loop is properly treated.
- Check refrigerant filter driers for excessive pressure drop; replace as necessary.
- Check chilled water strainers, clean as necessary.
- Check cooler heater operation.
- Check condition of condenser fan blades and that they are securely fastened to the motor shaft.
- Perform Service Test to confirm operation of all components.
- Check for excessive cooler approach (Leaving Chilled Water Temperature – Saturated Suction Temperature) which may indicate fouling. Clean cooler vessel if necessary.
- Obtain oil analysis; change as necessary.

## TROUBLESHOOTING

See Table 58 for an abbreviated list of symptoms, possible causes and possible remedies.

**Alarms and Alerts** — The integral control system constantly monitors the unit and generates warnings when abnormal or fault conditions occur. Alarms may cause either a circuit (Alert) or the whole machine (Alarm) to shut down. Alarms and Alerts are assigned codes as described in Table 59. The alarm/alert indicator LED on the Navigator™ module is illuminated when any alarm or alert condition is present. If an Alert is active, the Alarm Indicator LED will blink. If an Alarm is active, the Alarm Indicator LED will remain on. Currently active Alerts and Alarms can be found in (**Current Alarm, ALRM**).

The controller generates two types of alarms. Automatic reset alarms will reset without any intervention if the condition that caused the alarm corrects itself. Manual reset alarms require the service technician to check for the alarm cause and

reset the alarm. The following method must be followed to reset manual alarms:

Before resetting any alarm, first determine the cause of the alarm and correct it. To reset the alarm, set **R.ALM** to YES. The alarms will be reset. Indicator light will be turned off when switched correctly. Do not reset the chiller at random without first investigating and correcting the cause(s) of the failure.

Each alarm is described by a three or four-digit code. The first one or two digits indicate the alarm source and are listed in Fig. 62. The last two digits pinpoint the problem. See Table 59.

Alarm Descriptor	Alarm	
	th	.01
Alarm Prefix		
A1 – Compressor A1 Failure		
B1 – Compressor B1 Failure		
C1 – Compressor C1 Failure		
Co – Communication Failure		
FC – Factory Configuration Error		
MC – Master Chiller Configuration Error		
P – Process Failure		
Pr – Pressure Transducer Failure		
Sr – Service Notification		
th – Thermistor Failure		
<b>Alarm Suffix</b>		
Code Number to identify source		

**Fig. 62 — Alarm Description**

## DIAGNOSTIC ALARM CODES AND POSSIBLE CAUSES

### Thermistor Failure

Alarm 1 — Cooler Fluid Entering (th.01)

Alarm 2 — Cooler Fluid Leaving (th.02)

*Criteria for Trip* — This alarm criterion is tested whether the unit is on or off if the temperature as measured by the thermistor is outside of the range  $-40$  to  $245\text{ F}$  ( $-40$  to  $118.3\text{ C}$ ).

*Action to be Taken* — The unit shuts down normally, or is not allowed to start.

*Reset Method* — Automatic, the alarm will reset once the thermistor reading is within the expected range.

*Possible Causes* — If this condition is encountered, check the following items:

- sensor wiring to the Main Base Board
- sensor accuracy

See the Thermistors section on page 71 for thermistor description, identifiers and connections.

### Defrost Thermistor Failure

Alarm 3 — Circuit A (th.03)

Alarm 4 — Circuit B (th.04)

NOTE: These alarms are not used or supported. If this condition is encountered, confirm machine configuration.

**Table 58 — Troubleshooting**

<b>SYMPTOM</b>	<b>POSSIBLE CAUSE</b>	<b>POSSIBLE REMEDY</b>
<b>Unit Does Not Run</b>	Check for power to unit	<ul style="list-style-type: none"> <li>• Check overcurrent protection device.</li> <li>• Check non-fused disconnect (if equipped).</li> <li>• Restore power to unit.</li> </ul>
	Wrong or incorrect unit configuration	Check unit configuration.
	Active alarm	Check Alarm status. See the Alarms and Alerts section and follow troubleshooting instructions.
	Active operating mode	Check for Operating Modes. See the Operating Modes section and follow troubleshooting instructions
<b>Unit Operates too Long or Continuously</b>	Low refrigerant charge	Check for leak and add refrigerant.
	Compressor or control contacts welded	Replace contactor or relay.
	Air in chilled water loop	Purge water loop.
	Non-condensables in refrigerant circuit.	Remove refrigerant and recharge.
	Inoperative EXV	<ul style="list-style-type: none"> <li>• Check EXV, clean or replace.</li> <li>• Check EXV cable, replace if necessary.</li> <li>• Check EXV board for output signal.</li> </ul>
	Load too high	Unit may be undersized for application
<b>Circuit Does Not Run</b>	Active alarm	Check Alarm status. See the Alarms and Alerts section and follow troubleshooting instructions.
	Active operating mode	Check for Operating Modes. See the Operating Modes section and follow troubleshooting instructions.
<b>Circuit Does Not Load</b>	Active alarm	Check Alarm status. See the Alarms and Alerts section and follow troubleshooting instructions.
	Active operating mode	Check for Operating Modes. See the Operating Modes section and follow troubleshooting instructions.
	Low saturated suction temperature	See Operating Modes 21, 22 and 23.
	High circuit suction superheat	The circuit capacity is not allowed increase if circuit superheat is greater than 36°F (20 C). See Alarms 59-61 for potential causes.
	Low suction superheat	The circuit capacity is not allowed to increase if the circuit superheat is less than 18° F (10° C). See Alarms 62-64 for potential causes.
<b>Compressor Does Not Run</b>	Active alarm	Check Alarm status. See the Alarms and Alerts section and follow troubleshooting instructions.
	Active operating mode	Check for Operating Modes. See the Operating Modes section and follow troubleshooting instructions.
	Inoperative compressor contactor	<ul style="list-style-type: none"> <li>• Check control wiring.</li> <li>• Check scroll protection module.</li> <li>• Check contactor operation, replace if necessary.</li> </ul>
<b>Chilled Water Pump is ON, but the Machine is OFF</b>	Cooler freeze protection	Chilled water loop temperature too low. Check cooler heater.

LEGEND

EXV — Electronic Expansion Valve

**Table 59 — Alarm Codes**

PREFIX CODE	SUFFIX CODE	ALARM NUMBER	ALARM DESCRIPTION	REASON FOR ALARM	ACTION TAKEN BY CONTROL	RESET TYPE	PROBABLE CAUSE	
th	01	1	Cooler Entering Fluid Thermistor	Temperature measured by the controller is outside of the range of -40 F to 245 F (-40 C to 118 C)	Unit be shut down or not allowed to start	Automatic	Faulty Sensor, wiring error or failed main base board	
	02	2	Cooler Leaving Fluid Thermistor					
	03	3	Circuit A Defrost Thermistor	Temperature measured by the controller is outside of the range of -40 F to 245 F (-40 C to 118 C)	None	Automatic	Configuration error	
	04	4	Circuit B Defrost Thermistor					
	06	5	Condenser Entering Fluid Thermistor					
	07	6	Condenser Leaving Fluid Thermistor					
	08	7	Reclaim Condenser Entering Thermistor					
	09	8	Reclaim Condenser Leaving Thermistor					
	10	9	OAT Thermistor					Temperature measured by the controller is outside of the range of -40 F to 245 F (-40 C to 118 C)
	11	10	Master/Slave Common Fluid Thermistor	Temperature measured by the controller is outside of the range of -40 F to 245 F (-40 C to 118 C)	Dual chiller deactivated. Master and slave machines operate in stand-alone mode			
	12	11	Circuit A Suction Gas Thermistor	Temperature measured by the controller is outside of the range of -40 F to 245 F (-40 C to 118 C)	Circuit shut down or not allowed to start	Automatic	Faulty Sensor, wiring error, failed EXV or CPM board	
	13	12	Circuit B Suction Gas Thermistor					
	14	13	Circuit C Suction Gas Thermistor					
	15	14	Circuit A Discharge Gas Thermistor					
	16	15	Circuit B Discharge Gas Thermistor					
	17	16	Circuit C Discharge Gas Thermistor					
	18	17	Circuit A Condenser Sub-cooling Liquid Thermistor					Temperature measured by the controller is outside of the range of -40 F to 245 F (-40 C to 118 C)
	19	18	Circuit B Condenser Sub-cooling Liquid Thermistor					
	21	19	Space Temperature Thermistor	Temperature measured by the controller is outside of the range of -40 F to 245 F (-40 C to 118 C)	Alarm tripped	Automatic	Faulty Sensor, wiring error, failed EMM board	
	23	20	Cooler heater feedback thermistor	Temperature measured by the controller is outside of the range of -40 F to 245 F (-40 C to 118 C)	None	Automatic	Configuration error	
	24	21	Circuit A Economizer Gas Thermistor	Temperature measured by the controller is outside of the range of -40 F to 245 F (-40 C to 118 C)	Circuit economizer function disabled	Automatic	Faulty Sensor, wiring error, failed EXV board	
	25	22	Circuit B Economizer Gas Thermistor					
	26	23	Circuit C Economizer Gas Thermistor					
	Pr	01	24	Circuit A Discharge Transducer	Measured voltage is 0 vdc or SST > EWT and EXV < 50% for 1 minute	Circuit shut down or not allowed to start	Automatic	Faulty transducer, wiring error, failed main base board or fan board
		02	25	Circuit B Discharge Transducer				
03		26	Circuit C Discharge Transducer					
04		27	Circuit A Suction Transducer					
05		28	Circuit B Suction Transducer					
06		29	Circuit C Suction Transducer					
07		30	Circuit A Reclaim Pump-down Pressure Transducer	Measured voltage is 0 vdc or SST > EWT and EXV < 50% for 1 minute	None	Automatic	Configuration error	
08		31	Circuit B Reclaim Pump-down Pressure Transducer					

**LEGEND**

- |   |  |
|---|--|
| <b>CCN</b> — Carrier Comfort Network®     | <b>HPS</b> — High Pressure Switch          |
| <b>CPM</b> — Compressor Protection Module | <b>LWT</b> — Leaving Water Temperature     |
| <b>DX</b> — Direct Expansion              | <b>MOP</b> — Maximum Operating Pressure    |
| <b>EMM</b> — Energy Management Module     | <b>MTA</b> — Must Trip Amps                |
| <b>EWT</b> — Entering Water Temperature   | <b>OAT</b> — Outdoor Air Temperature       |
| <b>EXV</b> — Electronic Expansion Valve   | <b>SST</b> — Saturated Suction Temperature |
| <b>HGBP</b> — Hot Gas Bypass              | <b>UL</b> — Underwriters Laboratories      |



**Table 59 — Alarm Codes (cont)**

PREFIX CODE	SUFFIX CODE	ALARM NUMBER	ALARM DESCRIPTION	REASON FOR ALARM	ACTION TAKEN BY CONTROL	RESET TYPE	PROBABLE CAUSE
<b>Pr</b>	10	32	Circuit A Oil Pressure Transducer	Measured voltage is 0 vdc or SST > EWT and EXV < 50% for 1 minute	Circuit shut down or not allowed to start	Automatic	Faulty transducer, wiring error, failed CPM board
	11	33	Circuit B Oil Pressure Transducer				
	12	34	Circuit C Oil Pressure Transducer				
	13	35	Circuit A Economizer Pressure Transducer				
	14	36	Circuit B Economizer Pressure Transducer				
	15	37	Circuit C Economizer Pressure Transducer	Measured voltage is 0 vdc	Circuit shut down or not allowed to start	Automatic	Faulty transducer, wiring error, failed CPM board
<b>Co</b>	A1	38	Loss of communication with Compressor Board A	No communication with CPM board	Affected compressor shut down	Automatic	Wrong CPM address, wrong unit configuration, wiring error, power loss, failed CPM board
	B1	39	Loss of communication with Compressor Board B				
	C1	40	Loss of communication with Compressor Board C				
	E1	41	Loss of communication with EXV Board A	No communication with EXV board	Affected compressor shut down	Automatic	Wrong EXV board address, wrong unit configuration, wiring error, power loss, failed EXV board
	E2	42	Loss of communication with EXV Board B				
	E3	43	Loss of communication with EXV Board C				
	F1	44	Loss of communication with Fan Board 1	No communication with fan board	Circuit A/B shut down or not allowed to start (080-120 ton), Circuit A shut down or not allowed to start (130-500 ton)	Automatic	Wrong board address, wrong unit configuration, wiring error, loss of power, failed board
	F2	45	Loss of communication with Fan Board 2	No communication with fan board	Circuit B shut down or not allowed to start (130-500 ton)	Automatic	Wrong board address, wrong unit configuration, wiring error, loss of power, failed board
	F3	46	Loss of communication with Fan Board 3	No communication with fan board	Circuit C shut down or not allowed to start (400-500 ton)	Automatic	Wrong board address, wrong unit configuration, wiring error, loss of power, failed board
	01	47	Loss of communication with Free Cooling Board 1	No communication with free cooling board	None	Automatic	Configuration error
	02	48	Loss of communication with Free Cooling Board 2				
	03	49	Loss of communication with Energy Management Board	No communication with EMM board	Disable or not allow EMM functions 3 step and 4-20 mA and space temperature reset, occupancy override and ice build)	Automatic	Wrong board address, wrong unit configuration, wiring error, power loss to module, failed module
	04	50	Loss of communication with Heat Reclaim Board	No communication with Free Cooling Board	None	Automatic	Configuration error
	05	51	Loss of communication with AUX Board 6	No communication with HGBP/PUMP Board	Unit shut down or not allowed to start	Automatic	Wrong board address, wrong unit configuration, wiring error, power loss to module, failed module
<b>P</b>	01	52	Cooler Freeze Protection	Entering or leaving thermostat sensed a temperature at or below freeze point	Unit shut down or not allowed to start	Automatic, first occurrence in 24 hours; manual if multiple alarms within 24 hours	Faulty thermistor, faulty wiring, low water flow, low loop volume, fouled cooler, or freeze conditions
	02	53	Condenser Freeze Protection Circuit A	—	None	Automatic	Configuration error
	03	54	Condenser Freeze Protection Circuit B				
	04	55	Condenser Freeze Protection Circuit C				

**LEGEND**

<b>CCN</b> — Carrier Comfort Network®	<b>HPS</b> — High Pressure Switch
<b>CPM</b> — Compressor Protection Module	<b>LWT</b> — Leaving Water Temperature
<b>DX</b> — Direct Expansion	<b>MOP</b> — Maximum Operating Pressure
<b>EMM</b> — Energy Management Module	<b>MTA</b> — Must Trip Amps
<b>EWT</b> — Entering Water Temperature	<b>OAT</b> — Outdoor Air Temperature
<b>EXV</b> — Electronic Expansion Valve	<b>SST</b> — Saturated Suction Temperature
<b>HGBP</b> — Hot Gas Bypass	<b>UL</b> — Underwriters Laboratories

**Table 59 — Alarm Codes (cont)**

PREFIX CODE	SUFFIX CODE	ALARM NUMBER	ALARM DESCRIPTION	REASON FOR ALARM	ACTION TAKEN BY CONTROL	RESET TYPE	PROBABLE CAUSE
<b>P</b>	05	56	Circuit A Low Suction Temperature	Low saturated suction temperatures detected for a period of time	Circuit shut down	Automatic, first occurrence in 24 hours; manual if multiple alarms within 24 hours	Faulty thermistor, faulty wiring, low water flow, low loop volume, fouled cooler, or freeze conditions. Closed suction valve, DX units.
	06	57	Circuit B Low Suction Temperature				
	07	58	Circuit C Low Suction Temperature				
	08	59	Circuit A High Suction Superheat	EXV>98%, suction superheat > 30 F (-1 C), and SST<MOP for more than 5 minutes	Circuit shut down	Manual	Faulty transducer, faulty wiring, faulty thermistor, faulty EXV, low refrigerant charge, plugged or restricted liquid line
	09	60	Circuit B High Suction Superheat				
	10	61	Circuit C High Suction Superheat				
	11	62	Circuit A Low Suction Superheat	EXV<5% and either the suction superheat is less than the set point by at least 5 F (-15 C) or the suction temperature is greater than MOP set point for more than 5 minutes	Circuit shut down	Manual	Faulty transducer, faulty wiring, faulty thermistor, faulty EXV, or incorrect configuration
	12	63	Circuit B Low Suction Superheat				
	13	64	Circuit C Low Suction Superheat				
	14	65	Interlock Failure	Lockout Switch Closed	Unit shut down or not allowed to start	Automatic	Lockout Switch Closed on EMM board
	28	66	Electrical Box Thermostat Failure/Reverse Rotation	External pump interlock open	Unit shut down or not allowed to start	Automatic	External pump off. Faulty jumper wiring when channel not used
	29	67	Loss of communication with System Manager	Loss of communication with an external control device for more than 2 minutes	Unit change to stand-alone operation	Automatic	Faulty communication wiring, no power supply to the external controller
	30	68	Master/Slave communication Failure	Communication between the master and slave machines lost	Unit change to stand-alone operation	Automatic	Faulty communication wiring, no power or control power to the main base board of either module
	67	69	Circuit A Low Oil Pressure	Oil pressure and suction pressure differential is less than the set point	Circuit shut down	Automatic, first occurrence in 24 hours; manual if multiple alarms within 24 hours	Plugged oil filter, faulty oil transducer, oil check valve stuck, plugged oil strainer
	68	70	Circuit B Low Oil Pressure				
	69	71	Circuit C Low Oil Pressure				
	70	72	Circuit A Max Oil Filter Differential Pressure	Difference between discharge pressure and oil pressure is greater than 50 psi for more than 30 seconds	Circuit shut down	Manual	Plugged oil filter, closed oil valve, bad oil solenoid, oil check valve stuck, faulty oil pressure transducer
	71	73	Circuit B Max Oil Filter Differential Pressure				
	72	74	Circuit C Max Oil Filter Differential Pressure				
	84	75	Circuit A High Oil Filter Drop Pressure	Difference between discharge pressure and oil pressure is greater than 30 psi for more than 5 minutes	Alert generated	Manual	Plugged oil filter
85	76	Circuit B High Oil Filter Drop Pressure					
86	77	Circuit C High Oil Filter Drop Pressure					
75	78	Circuit A Low Oil Level	Oil level switch open	Circuit shut down or not allowed to start	Automatic, first occurrence in 24 hours; manual if multiple alarms within 24 hours	Low oil level, faulty switch, wiring error, failed CPM board	
76	79	Circuit B Low Oil Level					
77	80	Circuit C Low Oil Level					
<b>MC</b>	nn	81	Master chiller configuration error Number 01 to nn	Wrong or incompatible configuration data	Unit not allowed to start in Master-slave control	Automatic	Configuration error
<b>FC</b>	n0	82	No factory configuration	No Configuration	Unit not allowed to start	Automatic	Configuration error
	nn	83	Illegal factory configuration Number 01 to 04	Wrong or incompatible configuration data	Unit not allowed to start	Automatic	Configuration error (see Table 61)
<b>P</b>	31	84	Unit is in CCN emergency stop	Emergency stop command has been received	Unit shut down or not allowed to start	Automatic	Carrier Comfort Network® Emergency Stop command received
	32	85	Cooler pump #1 fault	Pump interlock status does not match pump status	Unit shuts down, if available, another pump will start	Manual	Faulty contacts, wiring error or low control voltage. Configuration error.
	33	86	Cooler pump #2 fault				
	15	87	Condenser Flow Switch Failure	—	None	Manual	Configuration error

**LEGEND**

- |   |  |
|---|--|
| <b>CCN</b> — Carrier Comfort Network®     | <b>HPS</b> — High Pressure Switch          |
| <b>CPM</b> — Compressor Protection Module | <b>LWT</b> — Leaving Water Temperature     |
| <b>DX</b> — Direct Expansion              | <b>MOP</b> — Maximum Operating Pressure    |
| <b>EMM</b> — Energy Management Module     | <b>MTA</b> — Must Trip Amps                |
| <b>EWT</b> — Entering Water Temperature   | <b>OAT</b> — Outdoor Air Temperature       |
| <b>EXV</b> — Electronic Expansion Valve   | <b>SST</b> — Saturated Suction Temperature |
| <b>HGBP</b> — Hot Gas Bypass              | <b>UL</b> — Underwriters Laboratories      |

**Table 59 — Alarm Codes (cont)**

PREFIX CODE	SUFFIX CODE	ALARM NUMBER	ALARM DESCRIPTION	REASON FOR ALARM	ACTION TAKEN BY CONTROL	RESET TYPE	PROBABLE CAUSE
P	34	88	Circuit A Reclaim Operation Failure	—	None	Manual	Configuration error
	35	89	Circuit B Reclaim Operation Failure	—	None	Manual	Configuration error
	37	90	Circuit A — Repeated high discharge gas overrides	Multiple capacity overrides due to high saturated discharge temperature	Circuit shut down	Automatic	Condenser air recirculation, dirty or plugged condenser coils, inaccurate discharge transducer, faulty condenser fan
	38	91	Circuit B — Repeated high discharge gas overrides				
	39	92	Circuit C — Repeated high discharge gas overrides				
	40	93	Circuit A — Repeated low suction temp overrides	Multiple capacity overrides due to low saturated suction temperature	Circuit shut down	Automatic	Inaccurate transducer, faulty EXV, low refrigerant charge, plugged or restricted liquid line filter drier.
	41	94	Circuit B — Repeated low suction temp overrides				
	42	95	Circuit C — Repeated low suction temp overrides				
	43	96	Low entering water temperature in heating	Not supported	—	—	—
	73	97	Condenser pump #1 default	—	None	Manual	Configuration error
	74	98	Condenser pump #2 default				
	78	99	Circuit A High Discharge Temperature	Discharge gas temperature is higher than 212 F (100 C) for more than 90 seconds	Circuit shut down	Manual	Faulty transducer/high pressure switch, low/restricted condenser flow
	79	100	Circuit B High Discharge Temperature				
	80	101	Circuit C High Discharge Temperature				
	81	102	Circuit A Low Economizer Pressure	The economizer pressure is below the suction pressure more than 14.5 psi for more than 10 seconds	Circuit shut down	Manual	Faulty transducer, faulty main base board, faulty wiring, closed suction service valve, faulty EXV
	82	103	Circuit B Low Economizer Pressure				
	83	104	Circuit C Low Economizer Pressure				
	87	105	Circuit A Slide Valve Control Unverifiable	If 100% load current is less than 1.1 times of 30% load current, or for 1 minute when active cooling setpoint is greater than 32 F (0°C).	None	Manual	Slide valve stuck, inaccurate initial current reading
	88	106	Circuit B Slide Valve Control Unverifiable				
	89	107	Circuit C Slide Valve Control Unverifiable				
90	108	Cooler flow switch set point configuration failure	—	None	Manual	Configuration error	
91	109	Cooler flow switch failure	Flow switch open	Unit shut down	Manual if unit is running, automatic otherwise	Faulty flow switch, low cooler flow, faulty wiring, faulty cooler pump, faulty main base board, minutes off time set to 0	
97	127	Water Exchanger Temperature Sensors Swapped	Control detects EWT below LWT for 1 minute	Unit shut down	Manual	Wiring error, EWT and LWT sensors swapped	
Sr	nn	110	Service maintenance alert Number # nn	Field programmed elapsed time has expired for maintenance time	None	Manual	Maintenance required
A1, B1, C1	01	111-01, 112-01, 113-01	Compressor Motor temperature too high	Compressor temperature higher than 232 F (111 C) for more than 90 seconds	Circuit shut down	Manual	Motor cooling solenoid or economizer (080,082 only) EXV failure, faulty CPM board, low refrigerant charge (090-500)
	02	111-02, 112-02, 113-02	Compressor Motor temperature out of range	Compressor temperature reading out of the range of -40 F to 245 F (-40 C to 118 C)	Circuit shut down	Manual	Faulty thermistor, faulty wiring, faulty CPM board
	03	111-03, 112-03, 113-03	Compressor High pressure switch protection	HPS input on CPM board open	Circuit shut down	Manual, press reset button on HPS	Loss of condenser air flow, operation beyond compressor envelope, faulty high pressure switch, faulty wiring, faulty CPM board

LEGEND

- |   |  |
|---|--|
| <b>CCN</b> — Carrier Comfort Network®     | <b>HPS</b> — High Pressure Switch          |
| <b>CPM</b> — Compressor Protection Module | <b>LWT</b> — Leaving Water Temperature     |
| <b>DX</b> — Direct Expansion              | <b>MOP</b> — Maximum Operating Pressure    |
| <b>EMM</b> — Energy Management Module     | <b>MTA</b> — Must Trip Amps                |
| <b>EWT</b> — Entering Water Temperature   | <b>OAT</b> — Outdoor Air Temperature       |
| <b>EXV</b> — Electronic Expansion Valve   | <b>SST</b> — Saturated Suction Temperature |
| <b>HGBP</b> — Hot Gas Bypass              | <b>UL</b> — Underwriters Laboratories      |

**Table 59 — Alarm Codes (cont)**

PREFIX CODE	SUFFIX CODE	ALARM NUMBER	ALARM DESCRIPTION	REASON FOR ALARM	ACTION TAKEN BY CONTROL	RESET TYPE	PROBABLE CAUSE
A1, B1, C1	04	111-04, 112-04, 113-04	Compressor Over current	CPM board detects high motor current compared with MTA setting	Circuit shut down	Manual	Operating beyond compressor envelope, incorrect configuration
	05	111-05, 112-05, 113-05	Compressor Locked rotor	CPM board detects locked rotor current compared with MTA setting	Circuit shut down	Manual	Compressor motor failure, unloader slide valve failure, compressor mechanical failure
	06	111-06, 112-06, 113-06	Compressor Phase loss L1	CPM board detects current unbalance greater than 65% for more than 1 second	Circuit shut down	Manual	Blown fuse, wiring error, loose terminals
	07	111-07, 112-07, 113-07	Compressor Phase loss L2				
	08	111-08, 112-08, 113-08	Compressor Phase loss L3				
	09	111-09, 112-09, 113-09	Compressor Low current alarm	CPM detects motor current less than a certain percentage of the MTA setting, compressor not operating	Circuit shut down	Manual	Power supply disconnected, blown fuse, wiring error, contact deenergized, faulty current toroid high pressure switch trip.
	10	111-10, 112-10, 113-10	Compressor Y delta starter current increase failure alarm	If the delta mode current is not 25% greater than the current in Y mode	Circuit shut down	Manual	Power supply to delta contactor not connected, faulty delta contactor or wiring, faulty CPM board
	11	111-11, 112-11, 113-11	Compressor Contactor failure	CPM board detects greater than 15% of MTA current for 10 seconds after shutting off the compressor contactor. Oil solenoid is energized.	Circuit shut down	Manual	Faulty contactor, contactor welded, wiring error
	12	111-12, 112-12, 113-12	Compressor Unable to stop motor	CPM board detects greater than 15% of MTA current for 10 seconds after three attempts	Circuit shut down	Manual	Faulty contactor, contactor welded, wiring error
	13	111-13, 112-13, 113-13	Compressor Phase reversal	CPM board detects phase reversal from current toroid	Circuit shut down	Manual	Terminal block power supply lead not in correct phase. Power supply leads going through toroid crossed
	14	111-14, 112-14, 113-14	Compressor MTA configuration fault	MTA setting is out of the allowed MTA range	Circuit shut down	Manual	Incorrect MTA setting, faulty CPM board
	15	111-15, 112-15, 113-15	Compressor Configuration switch mismatch	CPM board MTA setting do not match factory configuration	Circuit shut down	Manual	Incorrect CPM dip-switch setting, incorrect factory MTA setting, faulty CPM board
	16	111-16, 112-16, 113-16	Compressor Unexpected switch setting change	CPM board dipswitch S1 setting changed	Circuit shut down	Manual	Incorrect CPM dip-switch setting, faulty CPM board
	17	111-17, 112-17, 113-17	Compressor Power on reset	CPM board detects a power failure	Circuit shut down	Manual	Power supply interruption
	18	111-18, 112-18, 113-18	Compressor UL 1998 critical section software error	Software error	Circuit shut down	Manual	Electric noise, faulty CPM board
	19	111-19, 112-19, 113-19	Compressor UL 1998 current measure dual channel mismatch	Software error	Circuit shut down	Manual	Electric noise, faulty CPM board

LEGEND

- |   |  |
|---|--|
| <b>CCN</b> — Carrier Comfort Network®     | <b>HPS</b> — High Pressure Switch          |
| <b>CPM</b> — Compressor Protection Module | <b>LWT</b> — Leaving Water Temperature     |
| <b>DX</b> — Direct Expansion              | <b>MOP</b> — Maximum Operating Pressure    |
| <b>EMM</b> — Energy Management Module     | <b>MTA</b> — Must Trip Amps                |
| <b>EWT</b> — Entering Water Temperature   | <b>OAT</b> — Outdoor Air Temperature       |
| <b>EXV</b> — Electronic Expansion Valve   | <b>SST</b> — Saturated Suction Temperature |
| <b>HGBP</b> — Hot Gas Bypass              | <b>UL</b> — Underwriters Laboratories      |

### Thermistor Failure

Alarm 5 — Condenser Entering Fluid (th.06)

Alarm 6 — Condenser Leaving Fluid (th.07)

NOTE: These alarms are not used or supported. If this condition is encountered, confirm machine configuration.

### Condenser Reclaim Thermistor

Alarm 7 — Reclaim Entering Fluid (th.08)

Alarm 8 — Reclaim Leaving Fluid (th.09)

NOTE: Alarms 7 and 8 are not used or supported. If this condition is encountered, confirm machine configuration.

### Alarm 9 — Outdoor Air Temperature Thermistor Failure (th.10)

*Criteria for Trip* — This alarm criterion is tested whether the unit is ON or OFF. The alarm is tripped if the temperature measured by the outdoor air thermistor sensor is outside the range of –40 to 245 F (–40 to 118.3 C).

*Action to be Taken* — The unit shuts down normally, or is not allowed to start.

*Reset Method* — Automatic, the alarm will reset once the thermistor reading is within the expected range.

*Possible Causes* — If this condition is encountered, check the following items:

- sensor wiring to the Main Base Board
- a faulty thermistor

See the Thermistors section on page 71 for thermistor description, identifiers and connections.

### Alarm 10 — Master/Slave Common Fluid Thermistor (th.11)

*Criteria for Trip* — This alarm criterion is tested whether the unit is ON or OFF. The alarm will be tripped if the unit is configured as a master or a slave (**Master/Slave Select, MSSL**), leaving temperature control is selected (**Entering Fluid Control, EWTO**), and if the temperature measured by the CHWS (chilled water sensor) fluid sensor is outside the range of –40 to 245 F (–40 to 118.3 C).

*Action to be Taken* — Master/slave operation is disabled and the chiller returns to stand alone mode.

*Reset Method* — Reset is automatic when the thermistor reading is inside the range of –40 to 245 F (–40 to 118.3 C).

*Possible Causes* — If this condition is encountered, check the following items:

- sensor wiring to the Main Base Board
- a faulty thermistor

See the Thermistors section on page 71 for thermistor description, identifiers and connections.

### Suction Gas Thermistor

Alarm 11 — Circuit A (th.12)

Alarm 12 — Circuit B (th.13)

Alarm 13 — Circuit C (th.14)

*Criteria for Trip* — This alarm criterion is tested whether the unit is ON or OFF. If the suction gas temperature as measured by the thermistor is outside of the range –40 to 245 F (–40 to 118.3 C).

*Action to be Taken* — The affected circuit shuts down normally.

*Reset Method* — Automatic, once the thermistor reading is within the expected range. The affected circuit will restart once the alarm has cleared.

*Possible Causes* — If this condition is encountered, check the following items:

- sensor wiring to the EXV board
- board for a faulty channel
- a faulty thermistor

See the Thermistors section on page 71 for thermistor description, identifiers and connections.

### Circuit Discharge Gas Thermistor Sensor Failure

Alarm 14 — Circuit A (th.15)

Alarm 15 — Circuit B (th.16)

Alarm 16 — Circuit C (th.17)

*Criteria for Trip* — This alarm criterion is tested whether the unit is ON or OFF. The alarm is tripped if the temperature measured by the Outdoor Air Thermistor sensor is outside the range of –40 to 245 F (–40 to 118.3 C).

*Action to be Taken* — The unit shuts down normally, or is not allowed to start.

*Reset Method* — Automatic, the alarm will reset once the thermistor reading is within the expected range.

*Possible Causes* — If this condition is encountered, check the following items:

- sensor wiring to the CPM board
- a faulty thermistor
- a faulty channel on the board

See the Thermistors section on page 71 for thermistor description, identifiers and connections.

### Condenser Subcooling Liquid Thermistor

Alarm 17 — Circuit A (th.18)

Alarm 18 — Circuit B (th.19)

NOTE: Alarms 17 and 18 are not used or supported. If this condition is encountered, confirm machine configuration.

### Alarm 19 — Space Temperature Sensor Failure (th.21)

*Criteria for Trip* — This alarm criterion is checked whether the unit is ON or OFF and if Space Temperature Reset has been enabled. This alarm is generated if the outdoor-air temperature as measured by the thermistor is outside of the range –40 to 245 F (–40 to 118.3 C).

*Action to be Taken* — Unit operates under normal control. Temperature Reset based on Space Temperature is disabled.

*Reset Method* — Automatic, once the thermistor reading is within the expected range. The Space Temperature Reset will resume once the alarm has cleared.

*Possible Causes* — If this condition is encountered, check the following items:

- sensor wiring to the Energy Management Module
- board for a faulty channel
- a faulty thermistor

For thermistor descriptions, identifiers and connections, see the Thermistors section.

### Alarm 20 — Cooler Heater Feedback Sensor Thermistor (th.23)

NOTE: Alarm 20 is not used or supported. If this condition is encountered, confirm machine configuration.

### Economizer Gas Thermistor

Alarm 21 — Circuit A (th.24)

Alarm 22 — Circuit B (th.25)

Alarm 23 — Circuit C (th.26)

*Criteria for Trip* — This alarm criterion is tested whether the unit is ON or OFF. The alarm is tripped if the Economizer gas reading is outside the range of –40 to 245 F (–40 to 118.3 C).

*Action to be Taken* — The unit shuts down normally, or is not allowed to start.

*Reset Method* — Automatic, the alarm will reset once the thermistor reading is within the expected range.

*Possible Causes* — If this condition is encountered, check the following items:

- sensor wiring to the EXV board
- a faulty thermistor
- a faulty channel on the board

See the Thermistors section on page 71 for thermistor description, identifiers and connections.

#### Discharge Transducer

Alarm 24 — Circuit A (Pr.01)

Alarm 25 — Circuit B (Pr.02)

Alarm 26 — Circuit C (Pr.03)

*Criteria for Trip* — The criterion is tested whether the circuit is ON or OFF. This alarm is generated if the voltage as sensed by the MBB or Fan Board C (FBC) is 0 vdc, which corresponds to the Navigator™ display of -7 psi (-48.3 kPa).

*Action to be Taken* — The circuit is shut down normally, or not allowed to start.

*Reset Method* — Automatic, once the transducer voltage is greater than 0 vdc, which corresponds to the Navigator display of a value greater than -7 psi (-48.3 kPa).

*Possible Causes* — If this condition is encountered, check the following items:

- sensor wiring to Main Base Board (Alarms 24 and 25)
- sensor wiring to Fan Board C (Alarm 26)
- board for a faulty channel
- for a faulty transducer
- confirm unit configuration

#### Suction Pressure Transducer Failure

Alarm 27 — Circuit A (Pr.04)

Alarm 28 — Circuit B (Pr.05)

Alarm 29 — Circuit C (Pr.06)

*Criteria for Trip* — The criteria are tested whether the circuit is ON or OFF. The alarm is generated if one of the following criteria is met:

1. If the voltage as sensed by the MBB or Fan Board C is 0 vdc, which corresponds to the Navigator™ display of -7 psi (-48.3 kPa).
2. The circuit is ON in cooling mode and the Saturated Suction Temperature (**Saturated Suction Temp, SST**) for the circuit is greater than the Entering Water Temperature and EXV opening is less than 50% for more than 60 seconds.

*Action to be Taken* — The circuit is shut down immediately, or not allowed to start.

#### *Reset Method*

1. Automatic, once the transducer voltage is greater than 0 vdc, which corresponds to the Navigator display of a value greater than -7 psi (-48.3 kPa).
2. Automatic once the circuit's saturated suction temperature is lower than the Entering Water Temperature by 3° F (1.6° C). If this criterion trips the alarm 3 times within a 24-hour period, the alarm changes to a manual reset.

*Possible Causes* — If this condition is encountered, check the following items:

- sensor wiring to Main Base Board (Alarms 27 and 28)
- sensor wiring to Fan Board C (Alarm 29)
- board for a faulty channel
- faulty transducer
- faulty entering water temperature sensor
- unit configuration

#### Reclaim Pumpdown Pressure Transducer

Alarm 30 — Circuit A (Pr.07)

Alarm 31 — Circuit B (Pr.08)

NOTE: Alarms 30 and 31 are not used or supported. If this condition is encountered, confirm machine configuration.

#### Oil Pressure Transducer

Alarm 32 — Circuit A (Pr.10)

Alarm 33 — Circuit B (Pr.11)

Alarm 34 — Circuit C (Pr.12)

*Criteria for Trip* — The criteria are tested whether the circuit is ON or OFF. The alarm is generated if one of the following criteria is met:

1. If the voltage as sensed by the MBB or Fan Board C is 0 vdc, which corresponds to the Navigator display of -7 psi (-48.3 kPa).
2. The circuit is OFF and outside air temperature is below 35.6 F (2 C).
3. The circuit is OFF and the fluid type is brine.

*Action to be Taken* — The circuit is shut down immediately, or not allowed to start.

*Reset Method* — Automatic, once the transducer voltage is greater than 0 vdc.

*Possible Causes* — If this condition is encountered, check the following items:

- sensor wiring to CPM board
- board for a faulty channel
- faulty transducer
- plugged oil filter
- faulty oil solenoid valve coil
- stuck oil solenoid valve
- confirm unit configuration

#### Economizer Pressure Transducer Failure

Alarm 35 — Circuit A (Pr. 13)

Alarm 36 — Circuit B (Pr. 14)

Alarm 37 — Circuit C (Pr. 15)

*Criteria for Trip* — The criteria are tested whether the circuit is ON or OFF. The alarm is generated if the voltage as sensed by the MBB or Fan Board C is 0 vdc, which corresponds to the Navigator display of -7 psi (-48.3 kPa).

*Action to be Taken* — The circuit is shut down immediately, or not allowed to start.

*Reset Method* — Automatic, once the transducer voltage is greater than 0 vdc, which corresponds to the Navigator display of a value greater than -7 psi (-48.3 kPa).

*Possible Causes* — If this condition is encountered, check the following items:

- sensor wiring to EXV Board
- EXV board for a faulty channel
- faulty transducer
- faulty economizer EXV or EXV wiring
- faulty economizer EXV channel on the board
- closed or partially closed suction service valve
- confirm unit configuration

#### Loss of Communication with Compressor Board

Alarm 38 — Compressor Board A (Co.A1)

Alarm 39 — Compressor Board B (Co.B1)

Alarm 40 — Compressor Board C (Co.C1)

*Criteria for Trip* — The alarm criterion is tested whether the unit is ON or OFF. If communication with the Compressor Protection Module Board (CPM) is lost for a period of 10 seconds, the alarm will be generated.

*Action to be Taken* — The affected compressor will be shut down.

*Reset Method* — Automatic, if communication is established. If called for, the compressor will start normally.

*Possible Causes* — If this condition is encountered, check the following items:

- power supply to the affected CPM board
- address of the CPM
- local equipment network (LEN) wiring
- confirm unit configuration

#### Loss of Communication with EXV Board

Alarm 41 — Circuit A, EXV Board A (Co.E1)

Alarm 42 — Circuit B, EXV Board B (Co.E2)

Alarm 43 — Circuit C, EXV Board C (Co.E3)

*Criteria for Trip* — The alarm criterion is tested whether the unit is ON or OFF. If communication with EXVA, B or C is lost for a period of 10 seconds, the alarm will be triggered.

*Action to be Taken* — If running, Circuit A, B or C will shut down normally. If Circuit A, B or C is not operating, it will not be allowed to start.

*Reset Method* — Automatic, if communication is established, the unit will start normally.

*Possible Causes* — If this condition is encountered, check the following items:

- power supply to EXVA, B or C
- address of the EXV board
- local equipment network (LEN) wiring
- confirm unit configuration

#### Alarm 44 — Loss of Communication with Fan Board 1 (Co.F1)

*Criteria for Trip* — The criterion is tested whether the unit is ON or OFF. If communication with Fan Board A is lost for a period of 10 seconds, the alarm will be triggered.

*Action to be Taken* — If the number of fans per circuit is greater than four fans per circuit, Circuit A will shut down normally if they are running. Circuit B will continue to run. If the circuit or circuits controlled by the board are not running, then they will not be allowed to start.

*Reset Method* — Automatic, if communication is established, the unit will start normally.

*Possible Causes* — If this condition is encountered, check the following items:

- power supply to Fan Board A
- address of the Fan Board A
- local equipment network (LEN) wiring
- confirm unit configuration

#### Alarm 45 — Loss of Communication with Fan Board 2 (Co.F2)

*Criteria for Trip* — The criterion is tested whether the unit is ON or OFF, and only if Circuit A or B has more than four fans per circuit.

NOTE: Fan Board B controls Circuit B only.

*Action to be Taken* — If communication with Fan Board B is lost for a period of 10 seconds, the alarm will be triggered. If running, Circuit B will shut down normally. If Circuit B is not running, then it will not be allowed to start.

*Reset Method* — Automatic, if communication is established, the unit will start normally.

*Possible Causes* — If this condition is encountered, check the following items:

- power supply to Fan Board B
- address of the Fan Board B
- local equipment network (LEN) wiring
- confirm unit configuration

#### Alarm 46 — Loss of Communication with Fan Board 3 (Co.F3)

*Criteria for Trip* — The criterion is tested whether the unit is ON or OFF, and on units with three circuits only. If communication with Fan Board C is lost for a period of 10 seconds, the alarm will be triggered.

*Action to be Taken* — If running, Circuit C will shut down normally. If the circuit is not running, then it will not be allowed to start.

*Reset Method* — Automatic, if communication is established, the unit will start normally.

*Possible Causes* — If this condition is encountered, check the following items:

- power supply to Fan Board C
- address of the Fan Board C
- local equipment network (LEN) wiring

- confirm unit configuration

#### Loss of Communication with Free Cooling Board

Alarm 47 — Board 1 (Co.01)

Alarm 48 — Board 2 (Co.02)

NOTE: Alarms 47 and 48 are not used or supported. If this condition is encountered, confirm machine configuration.

#### Alarm 49 — Loss of Communication with Energy Management Module Board (Co.03)

*Criteria for Trip* — The criterion is tested whether the unit is ON or OFF and when a function that requires the Energy Management Module (EMM) is configured. If communication with the EMM is lost for a period of 10 seconds, the alarm will be triggered.

*Action to be Taken* — If any function controlled by the EMM (3-Step and 4-20 mA Demand Limit, 4-20 mA and Space Temperature Reset, Occupancy Override, and Ice Build) is active, that function will be terminated. If an EMM function is programmed, and communication is lost, the function will not be allowed to start.

*Reset Method* — Automatic, if communication is established, the functions will be enabled.

*Possible Causes* — If this condition is encountered, check the following items:

- The EMM is installed, (**EMM NRCP2 Board, EMM**). If **EMM NRCP2 Board, EMM=YES**, then check for a control option that requires the EMM that may be enabled (correct configuration if not correct).
- power supply to EMM
- address of the EMM
- local equipment network (LEN) wiring
- confirm unit configuration to be sure that no options that require the EMM are enabled

#### Alarm 50 — Loss of Communication with Heat Reclaim Board (Co.04)

NOTE: Alarm 50 is not used or supported. If this condition is encountered, confirm machine configuration.

#### Alarm 51 — Loss of Communication with AUX Board 6 (Co.05)

*Criteria for Trip* — The alarm criteria are checked whether the unit is ON or OFF. If units are configured for dual cooler pump control (**Cooler Pumps Sequence, PUMP=2,3,4**) or HGBP = YES. If communication with the AUX board is lost then the alarm will be generated.

*Action to be Taken* — Unit shut down or not allowed to start.

*Reset Method* — Automatic, if communication is established, the unit will start normally.

*Possible Causes* — If this condition is encountered, check the following items:

- power supply to the HGBP/PUMP board
- address of the HGBP/PUMP board
- local equipment network (LEN) wiring
- confirm network configuration

#### Alarm 52 — Cooler Freeze Protection (P.01)

*Criteria for Trip* — The alarm criteria are checked whether the unit is ON or OFF. If the entering or leaving water thermistor senses a temperature at the freeze point or less, the alarm will be generated. For a fresh water system (**Cooler Fluid Type, FLUD=1**), the freeze point is 34 F (1.1 C). For medium temperature brine systems (**Cooler Fluid Type, FLUD=2**), the freeze point is Brine Freeze Set Point (**Brine Freeze Setpoint, LOSP**).

*Action to be Taken* — Unit shut down or not allowed to start. Chilled water pump will be started.

*Reset Method* — Automatic, first occurrence in 24 hours if LWT rises to 6° F (3° C) above set point. Manual, if more than one occurrence in 24 hours.



*Possible Causes* — If this condition is encountered, check the following items:

- entering and leaving fluid thermistors for accuracy
- water flow rate
- loop volume — low loop volume at nominal flow rates can in extreme cases bypass cold water to the cooler
- freezing conditions
- heater tape and other freeze protection items for proper operation
- glycol concentration and adjust **LOSP** accordingly
- If the Leaving Water Set Point is above 40 F (4.4 C) and there is glycol in the loop, consider using the Medium Temperature Brine option (**Cooler Fluid Type, FLUD=2**) to utilize the brine freeze point instead of 34 F (1.1 C)

#### Condenser Freeze Protection

Alarm 53 — Circuit A (P.02)

Alarm 54 — Circuit B (P.03)

Alarm 55 — Circuit C (P.04)

NOTE: Alarms 53-55 are not used or supported. If this condition is encountered, confirm machine configuration.

#### Low Saturated Suction Temperature

Alarm 56 — Circuit A (P.05)

Alarm 57 — Circuit B (P.06)

Alarm 58 — Circuit C (P.07)

*Criteria for Trip* — The criteria are tested only when the circuit is ON. This alarm is generated if one of the following criteria is met:

- If the circuit Saturated Suction Temperature is below -13 F (-25 C) for more than 30 seconds or 40 seconds if OAT is less than 14 F (-10 C) or LWT is less than 36 F (2.2 C).
- If the circuit Saturated Suction Temperature is below -22 F (-30 C) for more than 10 seconds, or 20 seconds if OAT less than 50 F (10 C).

*Action to be Taken* — The circuit is shut down immediately.

Prior to the alarm trip, the control will take action to avoid the alarm. See Operating Modes 21, 22 and 23 on page 68.

*Reset Method* — Automatic, first occurrence in 24 hours. Manual, if more than one occurrence in 24 hours.

*Possible Causes* — If this condition is encountered, check the following items:

- sensor wiring to Main Base Board (Alarm 56 and 57) or Fan Board C (Alarm 58)
- board for a faulty channel
- faulty suction transducer
- cooler water flow
- loop volume
- EXV operation
- liquid line refrigerant restriction, filter drier, service valve, etc.
- refrigerant charge
- If the Leaving Water Set Point is above 40 F (4.4 C) and there is glycol in the loop, consider using the Medium Temperature Brine option (**Cooler Fluid Type, FLUD=2**) to utilize the brine freeze point instead of 34 F (1.1 C).
- Closed suction service valve on DX Cooler units.

#### High Suction Superheat

Alarm 59 — Circuit A (P.08)

Alarm 60 — Circuit B (P.09)

Alarm 61 — Circuit C (P.10)

*Criteria for Trip* — The criteria are tested only when the circuit is ON. This alarm is generated if *all* of the following criteria are met:

- The EXV position is equal to or greater than 98%.
- The circuit's Suction Superheat (Suction Gas Temperature - Saturated Suction Temperature) is greater than the superheat control set point.

- The circuit's Saturated Suction Temperature is less than Maximum Operating Pressure (MOP) set point (**EXV MOP Setpoint, MOP**) for more than 5 minutes.

*Action to be Taken* — The circuit is shut down normally.

*Reset Method* — Manual.

*Possible Causes* — If this condition is encountered, check the following items:

- suction pressure transducer wiring to Main Base Board (Alarm 59 and 60) or Fan Board C (Alarm 61)
- board for a faulty channel
- a faulty suction transducer
- suction gas thermistor wiring to EXV Board 1 (Alarm 41) or to EXV Board 2 (Alarm 43)
- suction gas thermistor sensor for accuracy
- for EXV Board 1 (Alarm 41) or EXV Board 2 (Alarm 42) faulty channel
- EXV operation
- a liquid line refrigerant restriction, filter drier, service valve, etc.
- refrigerant charge

#### Low Suction Superheat

Alarm 62 — Circuit A (P.11)

Alarm 63 — Circuit B (P.12)

Alarm 64 — Circuit C (P.13)

*Criteria for Trip* — The criteria are tested when the circuit is ON. This alarm is generated if the following criterion is met:

The EXV position is equal to or less than 5% and the circuit's Suction Superheat (Suction Gas Temperature - Saturated Suction Temperature) is less than the Suction Superheat Set Point (**EXVA Superheat Setpoint, SHPA, EXVB Superheat Setpoint, SHPB, or EXVC Superheat Setpoint, SHPC**) by at least 5° F (2.8° C) or the circuit Saturated Suction Temperature is greater than Maximum Operating Pressure (MOP) set point (**EXV MOP Setpoint, MOP**) for more than 5 minutes.

*Action to be Taken* — The circuit is shut down normally.

*Reset Method* — Automatic, first occurrence in 24 hours. Manual, if more than one occurrence in 24 hours.

*Possible Causes* — If this condition is encountered, check the following items:

- suction pressure transducer wiring to Main Base Board (Alarm 62 and 63) or Fan Board C (Alarm 64)
- board for a faulty channel
- faulty suction transducer
- suction gas thermistor wiring to EXV Board 1 (Alarm 41) or to EXV Board 2 (Alarm 42)
- suction gas thermistor sensor for accuracy
- EXV Board 1 (Alarm 41) or EXV Board 2 (Alarm 42) faulty channel
- EXV operation
- confirm maximum operating pressure set point
- refrigerant charge level

#### Alarm 65 — Interlock Failure (P.14)

*Criteria for Trip* — The criteria are tested whether the unit is ON or OFF. This alarm is generated if the lockout switch (located in the Energy Management Module) is closed during normal operation.

*Action to be Taken* — All compressors are shut down immediately without going through pumpdown, and is not allowed to start.

*Reset Method* — Automatic, first occurrence in 24 hours. Manual, if more than one occurrence in 24 hours.

*Possible Causes* — If this condition is encountered, check the following items:

- chilled water flow switch operation
- water flow. Be sure all water isolation valves are open and check water strainer for a restriction
- interlock wiring circuit

- power supply to the pump
- control signal to the pump controller
- chilled water pump operation
- cooler pump contactor for proper operation

**Alarm 66 — Electrical Box Thermostat Failure/Reverse Rotation (P.28)**

*Criteria for Trip* — The alarm criteria are checked whether the unit is ON or OFF. If channel 15A on the MBB, which is used for field wired external pump interlock, is open then the alarm will be generated.

*Action to be Taken* — Unit shut down or note allowed to start.

*Reset Method* — Automatic, if the channel is closed, the unit will start normally.

*Possible Causes* — If this condition is encountered, check the following items:

- jumper wiring on TB5-1 and TB5-2 when channel is not in use
- external pump status
- field wiring for the external pump interlock

**Alarm 67 — Loss of Communication with System Manager (P.29)**

*Criteria for Trip* — The criterion is tested whether the unit is ON or OFF. This alarm is generated if the System Manager had established communications with the machine and is then lost for more than 2 minutes.

*Action to be Taken* — The action to be taken by the control depends on the configuration. If Auto Start when SM lost is enabled, (**Cooler Heater Delta Spt, AU.SM=YES**), then the unit will force the CCN Chiller Start Stop to **ENBL** and clear all forced points from the System Manager. The unit will revert to stand-alone operation.

*Reset Method* — Automatic, once communication is re-established.

*Possible Causes* — If this condition is encountered, check the following items:

- communication wiring
- power supply to the System Manager and unit controls

**Alarm 68 — Master/Slave Communication Failure (P.30)**

*Criteria for Trip* — The criterion is tested whether the units are ON or OFF and a master and slave machine has been configured, (**Master/Slave Select, MSSL=1** and **Master/Slave Select, MSSL=2**). If communication is lost for more than 3 minutes, this alarm is generated.

*Action to be Taken* — Dual chiller control will be disabled and each unit will operate in Stand-Alone mode.

*Reset Method* — Automatic, once communication is re-established.

*Possible Causes* — If this condition is encountered, check the following items:

- CCN wiring
- control power to each Main Base Board, master and slave
- confirm correct configuration

**Low Oil Pressure**

Alarm 69 — Circuit A (P.67)

Alarm 70 — Circuit B (P.68)

Alarm 71 — Circuit C (P.69)

*Criteria for Trip* — The criteria are tested only when the compressor is ON. The alarm is generated if one of the following occurs, where:

*oil* = oil pressure transducer reading for the appropriate compressor

*sp* = suction pressure reading for the affected circuit

*dp* = discharge pressure reading for the affected circuit

$$\text{oil\_sp1} = 0.7 \times (\text{dp-sp}) + \text{sp}$$

$$\text{oil\_sp2} = \text{sp} + 7.2 \text{ psi (15 seconds after start)}$$

$$\text{oil\_sp2} = \text{sp} + 14.5 \text{ psi (45 seconds after start)}$$

If the compressor starts with the ambient temperature (OAT less than 36° F [2° C]) the oil pressure monitoring is delayed by 30 seconds.

*Action to be Taken* — The affected compressor will be stopped. The other compressors will continue to operate.

*Reset Method* — Manual.

*Possible Causes* — If this condition is encountered, check the following items:

- sensor wiring to the CPM Board
- board for a faulty channel
- faulty transducer
- plugged oil filter
- faulty oil solenoid valve coil
- stuck oil solenoid valve
- stuck check valve
- manual shut off valve to ensure it is fully open
- confirm unit configuration

**Max Oil Filter Differential Pressure Failure**

Alarm 72 — Circuit A (P.70)

Alarm 73 — Circuit B (P.71)

Alarm 74 — Circuit C (P.72)

*Criteria for Trip* — The criterion is tested when the compressor has been operating for at least 5 seconds. The alarm is generated if the difference between the Circuit Discharge Pressure and the Compressor Oil Pressure is greater than 50 psi (345 kPa) for more than 30 seconds.

*Action to be Taken* — The affected compressor will be turned off.

*Reset Method* — Manual

*Possible Causes* — If this condition is encountered, check the following items:

- check the discharge and oil sensor wiring to the Main Base Board and CPM board
- boards for a faulty channel
- faulty transducer
- plugged oil filter
- faulty oil solenoid valve coil
- stuck oil solenoid valve
- stuck check valve
- manual shut off valve to ensure it is fully open

Check the power supply to the System Manager and unit controls.

**High Oil Filter Pressure Drop**

Alarm 75 — Circuit A (P.84)

Alarm 76 — Circuit B (P.85)

Alarm 77 — Circuit C (P.86)

*Criteria for Trip* — The criterion is tested when the compressor has been operating for at least 5 seconds. The alarm is generated if the difference between the Circuit Discharge Pressure and the Compressor Oil Pressure is greater than 30 psi for more than 5 minutes.

*Action to be Taken* — The compressor will continue to run.

*Reset Method* — Manual

*Possible Causes* — If this condition is encountered, check the following items:

- discharge and oil sensor wiring to the Main Base Board and CPM board
- boards for a faulty channel
- faulty transducer
- plugged oil filter
- faulty oil solenoid valve coil
- oil solenoid valve stuck open
- stuck check valve
- manual shut off valve to ensure it is fully open

Check the power supply to the System Manager and unit controls.

#### Low Oil Level Failure

Alarm 78 — Circuit A (P.75)

Alarm 79 — Circuit B (P.76)

Alarm 80 — Circuit C (P.77)

*Criteria for Trip* — The criteria are tested whether the compressor is on or off. The alarm is generated if:

- The compressor is not running and an increase in capacity is required and the compressor is not started.
- The compressor is running and the oil level switch is open for more than 45 seconds.

*Action to be Taken* — The affected compressor will be turned off.

*Reset Method* — Automatic, when the oil level is elevated, first three times the alarm is tripped in a 24-hour period. Manual if alarm is tripped more than three times in a 24-hour period.

*Possible Causes* — If this condition is encountered, check the following items:

- oil level in the oil separator
- oil level switch wiring to the CPM board
- CPM board for a faulty channel
- faulty oil level switch
- oil solenoid valve stuck open

#### Alarm 81 — Master Chiller Configuration Error (MC.nn)

*Criteria for Trip* — The criterion is tested whether the unit is ON or OFF. The units must be configured as a Master and Slave machine (**Master/Slave Select, MSSL=1** and **Master/Slave Select, MSSL=2**), and one of the following configuration errors has been found. The “nn” refers to the error code listed in Table 60.

*Action to be Taken* — Unit not allowed to start in Master Slave control.

*Reset Method* — Automatic

*Possible Causes* — If this condition is encountered, check the following:

- CCN wiring.
- Control power to each Main Base Board, master and slave.
- Move to first position.
- Confirm unit configuration.

#### Alarm 82 — Initial Factory Configuration Required (FC.n0)

*Criteria for Trip* — The criterion is tested whether the unit is ON or OFF. The alarm will be generated if the **Unit Capacity Model, TONS=0**.

*Action to be Taken* — The unit is not allowed to start.

*Reset Method* — Automatic after factory configuration is complete. The configuration must be manually completed.

*Possible Causes* — If this condition is encountered, confirm the unit configuration.

#### Alarm 83 — Illegal Configuration (FC.nn)

*Criteria for Trip* — The criterion is tested whether the unit is ON or OFF. The alarm will be generated if the one of the following configuration errors is detected by the control. The “nn” refers to the error code listed in Table 61.

*Action to be Taken* — The unit is not allowed to start.

*Reset Method* — Automatic after reconfiguration is completed.

*Possible Causes* — If this condition is encountered, confirm the unit configuration (**None, UNIT**).

#### Alarm 84 — Unit is in Emergency Stop (P.31)

*Criteria for Trip* — The criterion is tested whether the units are ON or OFF and when the machine receives a Carrier Comfort Network® (CCN) command for an Emergency Stop.

*Action to be Taken* — Unit will stop, or will not allowed to start.

*Reset Method* — Automatic, once a return to normal command is received.

*Possible Causes* — If this condition is encountered, check for CCN Emergency Stop command.

#### Cooler Pump Fault

Alarm 85 — Pump 1 Fault (P.32)

Alarm 86 — Pump 2 Fault (P.33)

*Criteria for Trip* — The criterion is tested whether the units are ON or OFF. This alarm will be generated if the cooler pump interlock opens. When starting the pump, the control must read an open circuit for 3 consecutive reads. If the pump is operating and the circuit opens, the alarm will be generated immediately.

*Action to be Taken* — The pump and machine will be shut down. If there is another pump available, the control will start that pump, restart the machine and clear the alarm. If no other pump is available, the unit will remain OFF.

*Reset Method* — Manual.

*Possible Causes* — If this condition is encountered, check the following items:

- interlock wiring circuit
- control signal to the pump controller
- cooler pump contactor for proper operation
- control voltage for proper voltage (on 208-volt systems, be sure the proper tap on TRAN1 is utilized)

#### Alarm 87 — Condenser Flow Switch Failure (P.15)

NOTE: Alarm 87 is not used or supported. If this condition is encountered, confirm machine configuration.

#### Reclaim Operation Failure

Alarm 88 — Circuit A (P.34)

Alarm 89 — Circuit B (P.35)

#### Repeated High Discharge Gas Overrides

Alarm 90 — Circuit A (P.37)

Alarm 91 — Circuit B (P.38)

Alarm 92 — Circuit C (P.39)

*Criteria for Trip* — The criterion is tested when the circuit is ON. This alarm will be tripped if the circuit capacity is reduced more than 8 times in 30 minutes due to high discharge gas temperatures. If no override occurs in a 30-minute period, the counter is reset.

*Action to be Taken* — The affected circuit will be shut down.

*Reset Method* — Automatic, after 30 minutes. If the alarm is cleared via the Manual method, the counter will be reset to zero.

*Possible Causes* — If this condition is encountered, check the following items:

- Maximum Condensing Temperature (MCT) for the proper setting
- noncondensables in the refrigerant circuit
- condenser air re-circulation
- proper refrigerant charge (overcharged)
- operation beyond the limit of the machine
- condenser coils for debris or restriction
- condenser fans and motors for proper rotation and operation
- discharge service valve to be sure that it is open. Check the discharge pressure transducer for accuracy
- confirm unit configuration

**Table 60 — Master/Slave Alarm Code**

MC ERROR CODE	MASTER	SLAVE	DESCRIPTION
01	X	X	The master or slave water pump is not configured while the control of the lag unit pump is required ( <i>lag_pump = 1</i> )
02	X		Master and slave units have the same network address.
03	X		There is no slave configured at the slave address
04	X		Slave <i>pump_seq</i> incorrect configuration
05	X		There is a conflict between the master and the slave LWT option: the master is configured for EWT control while the slave is configured for LWT control.
06	X		There is a conflict between the master and the slave LWT option: the master is configured for LWT control while the slave is configured for EWT control.
07	X		There is a conflict between the master and the slave pump option: the master is configured for lag pump control while the slave is not configured for lag pump control.
08	X		There is a conflict between the master and the slave pump option: the master is not configured for lag pump control while the slave is configured for lag pump control.
09	X	X	The slave chiller is in local or remote control ( <i>chilstat = 3</i> )
10	X	X	The slave chiller is down due to fault ( <i>chilstat = 5</i> )
11	X		The master chiller operating type is not Master: <i>master_oper_typ</i>
12	X	X	No communication with slave.
13	X		Master and slave heat cool status are not the same.

**LEGEND**

EWT — Entering Water Temperature  
 LWT — Leaving Water Temperature

**Table 61 — Illegal Configuration Alarm Code**

FC ERROR CODE	DESCRIPTION
01	Unit size is unknown.
02	Reclaim option selected for Heat Pump machine.
03	Hot Gas Bypass configured for a Heat Pump machine.
04	Number of Fans controlled by low ambient temperature head pressure control is greater than expected.

Repeated Low Suction Temperature Protection

Alarm 93 — Circuit A (P.40)  
 Alarm 94 — Circuit B (P.41)  
 Alarm 95 — Circuit C (P.42)

*Criteria for Trip* — The criterion is tested when the circuit is ON. If the circuit operates and if more than 8 successive circuit capacity decreases (stop the compressor) have occurred because of low suction temperature protection overrides, the circuit alarm will be tripped. If no override has occurred for more than 30 minutes, the override counter will be reset to zero.

*Action to be Taken* — ALARM\_LED will be set to blinking. Alert relay will be energized.

*Reset Method* — Automatic, when the override counter returns to zero. If the alarm is cleared via the Manual method, the counter will be forced to zero.

*Possible Causes* — If this condition is encountered, check the following items:

- suction transducer for accuracy
- suction transducer wiring
- EXV operation
- proper refrigerant charge (undercharged)
- evaporator loop for low water flow
- evaporator leaving water temperature
- suction service valve to be sure it is open
- plugged filter drier

Alarm 96 — Low Entering Water Temperature in Heating (P.43)

NOTE: Alarm 96 is not used or supported. If this condition is encountered, confirm machine configuration.

Condenser Default

Alarm 97 — Pump 1 (P.73)  
 Alarm 98 — Pump 2 (P.74)

NOTE: Alarms 97 and 98 are not used or supported. If this condition is encountered, confirm machine configuration.

High Discharge Temperature

Alarm 99 — Circuit A (P.78)  
 Alarm 100 — Circuit B (P.79)  
 Alarm 101 — Circuit C (P.80)

*Criteria for Trip* — The criterion is tested when the compressor is operating. This alarm will be tripped if the discharge gas temperature is higher than 212 F (100 C) for more than 90 seconds.

*Action to be Taken* — The affected compressor will be stopped.

*Reset Method* — Manual.

*Possible Causes* — If this condition is encountered, check the following items:

- noncondensables in the refrigerant circuit
- condenser air re-circulation
- proper refrigerant charge (undercharged) EXV operation
- EXV operation
- operation beyond the limit of the machine
- condenser coils for debris or restriction
- condenser fans and motors for proper rotation and operation
- the discharge service valve to be sure that it is open, check the discharge pressure transducer for accuracy
- confirm unit configuration

Low Economizer Pressure

Alarm 102 — Circuit A (P.81)  
 Alarm 103 — Circuit B (P.82)  
 Alarm 104 — Circuit C (P.83)

*Criteria for Trip* — The criterion is tested when the compressor is operating to prevent pumpdown conditions when the suction service valve is closed. This alarm will be tripped if the economizer pressure is below the suction pressure more than 1 bar (14.5 psi) for more than 10 seconds.

*Action to be Taken* — The affected compressor will be stopped.

*Reset Method* — Manual.

*Possible Causes* — If this condition is encountered, check the following items:

- suction service valve is closed
- sensor wiring to the EXV boards

- boards for faulty channels
- faulty transducer
- economizer EXV operation

Slide Valve Control Unverifiable

Alarm 105 — Circuit A (P.87)  
 Alarm 106 — Circuit B (P.88)  
 Alarm 107 — Circuit C (P.89)

*Criteria for Trip* — The criteria are tested when the compressor is operating and the active cooling set point is greater than 32° F (0° C). This alarm will be tripped if the circuit is operating at 100% of capacity and the measured current is less than 1.1 times the current at fully unloaded 30% for more than one minute.

*Action to be Taken* — The affected compressor will continue to run.

*Reset Method* — Manual.

*Possible Causes* — If this condition is encountered, check the following items:

- faulty unloader solenoid valves
- faulty unloader solenoid coils
- wiring of the unloader solenoid valves
- CPM board for faulty channels
- current transformer reading for accuracy

Alarm 108 — Cooler Flow Switch Setpoint Configuration Failure (P.90)

NOTE: Alarm 108 is not used or supported. If this condition is encountered, confirm machine configuration.

Alarm 109 — Cooler Flow Switch Failure (P.91)

*Criteria for Trip* — The criteria are tested when the unit is on or off. This alarm will be tripped when the unit is on if:

- The flow switch fails to close after the Off/On delay.
- If the master/slave control is active, the unit is the lag chiller and if the cooler flow switch fails to close within one minute after the cooler pump was restarted. The alarm is ignored if the lag cooler pump is stopped as a result of master/slave control.
- The flow switch is opened during normal operation.

The alarm will be tripped when the unit is off if:

- The cooler pump control is enabled (**Cooler Pumps Sequence, PUMP=0**) and the cooler flow switch is checked when the pump is enabled (**Flow Checked if C Pump Off, PLOC**) and the cooler flow switch is closed after the cooler pump is commended OFF for more than 2 minutes.
- The flow switch fails to close after the Off/On delay after the cooler pump has been turned on to protect the cooler from freezing (**Cooler Pumps Sequence, PUMP=0**).

*Action to be Taken* — For criteria for trip A1 and A2, the compressors will not be started.

For criteria for trip A3, all compressors will be stopped without going through pumpdown. Cooler pump will be stopped with no delay.

For criteria for trip B1, the unit will not start.

*Reset Method* — Manual if at least one compressor is operating. Automatic if no compressors are operating.

*Possible Causes* — If this condition is encountered, check the following items:

- a faulty flow switch
- flow switch wiring
- Main Base Board for a faulty channel
- Minutes off time set to 0 (DELY, unit off to on delay)

Alarm 127 — Water Exchanger Temperature Sensors Swapped (P.97)

*Criteria for Trip* — The alarm criterion is checked when the chiller is ON and one or more compressors is running. This alarm will be tripped if the entering water temperature is less than the leaving water temperature for more than 1 minute.

*Action to be Taken* — The chiller is shut down immediately.

*Reset Method* — Manual.

*Possible Causes* — If this condition is encountered, check the following items:

- Check LWT and EWT wiring at main base board (connector J6, channels 1,2).
- Check for a faulty entering or leaving water temperature sensor.
- Check cooler nozzles for proper water temperature sensor locations.

Alarm 110 — Service Maintenance Alert (Sr.nn)

*Criteria for Trip* — This alert is tested whether the unit is ON or OFF and when the Servicing Alert decisions listed under **Time Clock**→**MCFG** have been enabled. The alarm will be generated if the one of the following configuration errors is detected by the control. The “nn” refers to the error code listed in Table 62.

**Table 62 — Service Maintenance Alert Codes**

CODE	DESCRIPTION
Sr.01	Circuit A Loss of Refrigerant Charge
Sr.02	Circuit B Loss of Refrigerant Charge
Sr.03	Circuit C Loss of Refrigerant Charge
Sr.04	Water Loop Size Warning
Sr.05	Air Exchanger Cleanliness Warning
Sr.06	Cooler Pump 1 Servicing Required
Sr.07	Cooler Pump 2 Servicing Required
Sr.08	Condenser Pump 1 Servicing Required
Sr.09	Condenser Pump 2 Servicing Required
Sr.10	Water Filter Servicing Required
Sr.11	Compressor A Oil Filter Servicing Required
Sr.12	Compressor B Oil Filter Servicing Required
Sr.13	Compressor C Oil Filter Servicing Required

*Action to be Taken* — None.

*Reset Method* — Manual, after the service has been completed.

*Possible Causes* — If the Sr-01, 02, or 03 conditions are encountered, check the following items:

- refrigerant charge
- sensor wiring to the Main Base Board
- sensor for accuracy

Compressor Motor Temperature Too High

Alarm 111-01 — Circuit A (A1.01)  
 Alarm 112-01 — Circuit B (B1.01)  
 Alarm 113-01 — Circuit C (C1.01)

*Criteria for Trip* — The alarm criteria are checked when the compressor is ON. This alarm will be generated if:

- The temperature is greater than 245 F (118 C) and it has been greater than 212 F (100 C) for 10 consecutive seconds.
- The compressor temperature is greater than 232 F (111 C) for 90 seconds (but less than 250 F [120 C]).

*Action to be Taken* — The circuit shuts down immediately.

*Reset Method* — Manual

*Possible Causes* — If this condition is encountered, check the following items:

- faulty wiring and loose plugs
- faulty CPM board

Compressor Motor Temperature Out of Range

Alarm 111-02 — Circuit A (A1.02)  
 Alarm 112-02 — Circuit B (B1.02)  
 Alarm 113-02 — Circuit C (C1.02)

*Criteria for Trip* — The alarm criterion is checked when the compressor is ON. This alarm will be generated if: the temperature is greater than 245 F (118 C) and it has NOT been greater than 212 F (100 C) for 10 consecutive seconds.

*Action to be Taken* — The compressor will be stopped.

*Reset Method* — Manual

*Possible Causes* — If this condition is encountered, check the following items:

- faulty compressor temperature thermistor
- faulty wiring and loose plugs
- faulty CPM board

#### Compressor High Pressure Switch Protection

Alarm 111-03 — Circuit A (A1.03)

Alarm 112-03 — Circuit B (B1.03)

Alarm 113-03 — Circuit C (C1.03)

*Criteria for Trip* — The alarm criterion is checked when the compressor is ON. This alarm will be generated if the circuit high-pressure switch (HPS) opens for more than 2 seconds. The CPM board monitors the HPS switch.

*Action to be Taken* — The compressor will be stopped.

*Reset Method* — Manual (reset button on switch)

*Possible Causes* — If this condition is encountered, check the following items:

- condenser fan or contactor failure or loss of condenser air flow
- compressor operating beyond the operation envelope
- faulty high pressure switch or wiring
- faulty CPM board

#### Compressor Overcurrent

Alarm 111-04 — Circuit A (A1.04)

Alarm 112-04 — Circuit B (B1.04)

Alarm 113-04 — Circuit C (C1.04)

*Criteria for Trip* — The alarm criterion is checked when the compressor is ON. This alarm will be generated if the CPM board detects a motor current greater than 93% MTA (must trip amps) and less than 2 times that for more than 1.7 seconds.

*Action to be Taken* — The compressor will be stopped.

*Reset Method* — Manual

*Possible Causes* — If this condition is encountered, check the following items:

- Compressor operating beyond the operation envelope.
- Incorrect MTA setting.

#### Compressor Locked Rotor

Alarm 111-05 — Circuit A (A1.05)

Alarm 112-05 — Circuit B (B1.05)

Alarm 113-05 — Circuit C (C1.05)

*Criteria for Trip* — The alarm criterion is checked during start-up when the compressor is ON. This alarm will be generated if the CPM board detects a high motor current compared with the MTA (must trip amps) setting for more than 450 ms.

*Action to be Taken* — The compressor will be stopped.

*Reset Method* — Manual

*Possible Causes* — If this condition is encountered, check the following items:

- compressor mechanical failure
- unloader slide valve failure
- compressor motor failure

#### Compressor Phase Loss

Alarm 111-06 — Circuit A L1 (A1.06)

Alarm 112-06 — Circuit B L1 (B1.06)

Alarm 113-06 — Circuit C L1 (C1.06)

Alarm 111-07 — Circuit A L2 (A1.07)

Alarm 112-07 — Circuit B L2 (B1.07)

Alarm 113-07 — Circuit C L2 (C1.07)

Alarm 111-08 — Circuit A L3 (A1.08)

Alarm 112-08 — Circuit B L3 (B1.08)

Alarm 113-08 — Circuit C L3 (C1.08)

*Criteria for Trip* — The alarm criteria are checked during startup when the compressor is ON. This alarm will be generated if:

- The current unbalance on any of the 3 phases is greater than 48% for more than 1 second continuously during start-up.
- The current unbalance on any of the 3 phases is greater than 48% for more than 2 seconds continuously during runtime.

*Action to be Taken* — The compressor will be stopped.

*Reset Method* — Manual

*Possible Causes* — If this condition is encountered, check the following items:

- power failure
- blown fuse or tripped circuit breaker
- power wiring errors or loose terminals

#### Compressor Low Current

Alarm 111-09 — Circuit A (A1.09)

Alarm 112-09 — Circuit B (B1.09)

Alarm 113-09 — Circuit C (C1.09)

*Criteria for Trip* — The alarm criteria are checked when the compressor is ON. This alarm will be generated if:

- The current is less than 15% MTA on all three legs for more than 1 second for Wye-Delta start units.
- If the current is less than 15% of MTA on all three legs for more than 1 second for direct start units.

*Action to be Taken* — The compressor will be stopped.

*Reset Method* — Manual

*Possible Causes* — If this condition is encountered, check the following items:

- power failure
- blown fuse or tripped circuit breaker
- deenergized contactor
- faulty current toroid
- high pressure switch (HPS) trip (when auto reset HPS is used)

#### Compressor Wye-Delta Starter Current Increase Failure

Alarm 111-10 — Circuit A (A1.10)

Alarm 112-10 — Circuit B (B1.10)

Alarm 113-10 — Circuit C (C1.10)

*Criteria for Trip* — The alarm criterion is checked during compressor start-up. This alarm will be generated if the current in Delta mode is not more than 25% greater than the current in Y mode within 550 ms.

*Action to be Taken* — The compressor will be stopped.

*Reset Method* — Manual

*Possible Causes* — If this condition is encountered, check the following items:

- power supply failure to the delta contactor
- faulty wiring to the delta contactor
- faulty CPM board
- faulty current toroid

#### Compressor Contactor Failure

Alarm 111-11 — Circuit A (A1.11)

Alarm 112-11 — Circuit B (B1.11)

Alarm 113-11 — Circuit C (C1.11)

*Criteria for Trip* — The alarm criterion is checked during compressor shutdown. This alarm will be generated if the current is greater than 15% of the MTA on at least one phase for 10 continuous seconds.

*Action to be Taken* — The compressor will be stopped.

*Reset Method* — Manual

*Possible Causes* — If this condition is encountered, check the following items:

- faulty or welded contactor
- faulty wiring
- faulty CPM board



### Compressor Unable to Stop Motor

Alarm 111-12 — Circuit A (A1.12)

Alarm 112-12 — Circuit B (B1.12)

Alarm 113-12 — Circuit C (C1.12)

*Criteria for Trip* — The alarm criterion is checked during compressor shutdown. This alarm will be generated if after three attempts to turn off the compressor outputs and the current is still greater than 15% of the MTA on at least one phase for 10 continuous seconds.

*Action to be Taken* — The compressor will be stopped.

*Reset Method* — Manual

*Possible Causes* — If this condition is encountered, check the following items:

- faulty or welded contactor
- faulty wiring

### Compressor Phase Reversal

Alarm 111-13 — Circuit A (A1.13)

Alarm 112-13 — Circuit B (B1.13)

Alarm 113-13 — Circuit C (C1.13)

*Criteria for Trip* — The alarm criterion is checked during compressor start-up. This alarm will be generated if the CPM board detects a phase reversal from the current toroid.

*Action to be Taken* — The compressor will be stopped.

*Reset Method* — Manual

*Possible Causes* — If this condition is encountered, check the following items:

- if power supply lead at the terminal block is not operating at the correct phase
- if power supply is crossed when going through the current toroid

### Compressor MTA Configuration Fault

Alarm 111-14 — Circuit A (A1.14)

Alarm 112-14 — Circuit B (B1.14)

Alarm 113-14 — Circuit C (C1.14)

*Criteria for Trip* — The alarm criterion is checked whether the compressor is ON or OFF. This alarm will be generated if the MTA setting is out of the allowed MTA range.

*Action to be Taken* — The compressor will be stopped.

*Reset Method* — Manual

*Possible Causes* — If this condition is encountered, check the following items:

- incorrect MTA settings
- faulty CPM board

### Compressor Configuration Switch Mismatch

Alarm 111-15 — Circuit A (A1.15)

Alarm 112-15 — Circuit B (B1.15)

Alarm 113-15 — Circuit C (C1.15)

*Criteria for Trip* — The alarm criterion is checked whether the compressor is ON or OFF. This alarm will be generated if the CPM board S1 and S2 setting does not match software configuration.

*Action to be Taken* — The compressor will be stopped.

*Reset Method* — Manual

*Possible Causes* — If this condition is encountered, check the following items:

- incorrect CPM board settings
- faulty CPM board

### Compressor Unexpected Switch Setting Change

Alarm 111-16 — Circuit A (A1.16)

Alarm 112-16 — Circuit B (B1.16)

Alarm 113-16 — Circuit C (C1.16)

*Criteria for Trip* — The alarm criterion is checked when the compressor is ON. This alarm will be generated if the CPM board S1 setting has changed.

*Action to be Taken* — The compressor will be stopped.

*Reset Method* — Manual

*Possible Causes* — If this condition is encountered, check the following items:

- incorrect CPM board settings
- faulty CPM board

### Compressor Power on Reset

Alarm 111-17 — Circuit A (A1.17)

Alarm 112-17 — Circuit B (B1.17)

Alarm 113-17 — Circuit C (C1.17)

*Criteria for Trip* — The alarm criterion is checked when the compressor is ON. This alarm will be generated if the CPM board detects a power failure.

*Action to be Taken* — The compressor will be stopped.

*Reset Method* — Manual

*Possible Causes* — If this condition is encountered, check for power interruptions.

### Compressor UL 1998 Critical Section Software Error

Alarm 111-18 — Circuit A (A1.18)

Alarm 112-18 — Circuit B (B1.18)

Alarm 113-18 — Circuit C (C1.18)

*Criteria for Trip* — The alarm criterion is checked when the compressor is ON. This alarm will be generated if the CPM board detects a software error.

*Action to be Taken* — The compressor will be stopped.

*Reset Method* — Manual

*Possible Causes* — If this condition is encountered, check the following items:

- electrical noise
- faulty CPM board

### Compressor UL 1998 Current Measure Dual Channel Mismatch

Alarm 111-19 — Circuit A (A1.19)

Alarm 112-19 — Circuit B (B1.19)

Alarm 113-19 — Circuit C (C1.19)

*Criteria for Trip* — The alarm criterion is checked when the compressor is ON. This alarm will be generated if the CPM board detects a software error.

*Action to be Taken* — The compressor will be stopped.

*Reset Method* — Manual

*Possible Causes* — If this condition is encountered, check the following items:

- electrical noise
- faulty CPM board

**Service Test** — Main power and control circuit power must be on for Service Test.

The Service Test function is used to verify proper operation of various devices within the chiller, such as condenser fan(s), compressors, minimum load valve solenoid (if installed), cooler pump(s) and remote alarm relay. This is helpful during the start-up procedure to determine if devices are installed correctly. See Fig. 63-65 for 30XA wiring diagrams.

To use the Service Test mode, the Enable/Off/Remote Contact switch must be in the OFF position. Use the display keys to move to the Service Test mode. The items are described in the Service Test table. There are two sub-modes available. **Service Test Enable, *TREQ*** allows for manual control of the compressors and minimum load control. In this mode the compressors will operate only on command. The capacity control and head pressure control algorithms will be active. The condenser fans will operate along with the EXVs. There must be a load on the chiller to operate for an extended period of time. All circuit safeties will be honored during the test. **Quick Test Enable, *QREQ*** allows for test of EXVs, condenser fans, pumps, low ambient head pressure control speed control, oil

separator, cooler heaters, oil solenoids, unloader solenoids and status points (alarm relays, running status and chiller capacity). If there are no keys pressed for 5 minutes, the active test mode will be disabled.

To enter the Manual Control mode with the Navigator™ display, the Enable/Off/Remote Contact switch must be in the OFF position. Move the LED to the Service Test mode. Press **ENTER** to access **TEST**. Press **ENTER** to access **T.REQ**. Press **ENTER** and the display will show **OFF**. Press **ENTER** and **OFF** will flash. Enter the password if required. Use either arrow key to change the **T.REQ** value to **ON** and press **ENTER**. Place the Enable/Off/Remote Switch in the enable position. Manual Control mode is now active. Press the arrow keys to move to the appropriate item. To activate an item locate the item, press **ENTER** and the display will show **OFF**. Press **ENTER** and **OFF** will flash. Use either arrow key to change the value to **ON** and press **ENTER**. The item should be active. To turn the item off, locate the item, press **ENTER** and the display will show **ON**. The chiller must be enabled by turning the Enable/Off/Remote Contact switch to Enable. Press **ENTER** and **ON** will flash. Use either arrow key to change the value to **OFF** and press **ENTER**. The item should be inactive.

To enter the Quick Test mode, the Enable/Off/Remote Contact switch must be in the OFF position. Move the LED to the Service Test mode. Press **ENTER** to access **TEST**. Use the **▼** key until the display reads **QUIC**. Press **ENTER** to

access **Q.REQ**. Press **ENTER** and the display will show **OFF**. Press **ENTER** and **OFF** will flash. Enter the password if required. Use either arrow key to change the **QUIC** value to **ON** and press **ENTER**. Quick Test mode is now active. Follow the same instructions for the Manual Control mode to activate a component (see Table 63).

Example — Test the condenser fan A1.

Power must be applied to the unit. Enable/Off/Remote Contact switch must be in the OFF position.

Test the condenser fans, cooler pump(s) and alarm relay by changing the item values from OFF to ON. These discrete outputs are then turned off if there is no keypad activity for 10 minutes. Test the compressor and minimum load valve solenoid (if installed) outputs in a similar manner. The minimum load valve solenoids will be turned off if there is no keypad activity for 10 minutes. Compressors will stay on until the operator turns them off. The Service Test mode will remain enabled for as long as there is one or more compressors running. All safeties are monitored during this test and will turn a compressor, circuit or the machine off if required. Any other mode or sub-mode can be accessed, viewed, or changed during the Manual Control mode only. The **STAT** item (**Run Status**→**VIEW**) will display “0” as long as the Service mode is enabled. The **TEST** sub-mode value must be changed back to OFF before the chiller can be switched to Enable or Remote contact for normal operation.

NOTE: There may be up to a one-minute delay before the selected item is energized.

**Table 63 — Testing Circuit A Oil Solenoid**

MODE (Red LED)	SUB-MODE	KEYPAD ENTRY	ITEM	DISPLAY EXPANSION	VALUE DESCRIPTION (Units)	COMMENT
SERVICE TEST		ENTER		Service Test Mode		
	TEST	↓		Manual Sequence		
	QUIC	ENTER	Q.REQ			
			PASS WORD			Password may be required
		ENTER			0111	
		ENTER ENTER ENTER ENTER				Each ENTER will lock in the next digit. If 0111 is not the password, use the arrow keys to change the password digit and press ENTER when correct.
		ENTER	Q.REQ			Returns to the original field
		ENTER			OFF	
		ENTER			OFF	OFF will flash
		↓			ON	The Enable/Off/Remote Contact switch must be in the OFF position.
		ESCAPE	Q.REQ			
		↓	EXV.A			
		↓	Press 15 times.			
		↓	OLS.A	Oil Solenoid Cap.A		
		ENTER			OFF	
		ENTER			OFF	OFF will flash
		↑			ON	
		ENTER			ON	OLS.A will turn on.
		ENTER			ON	1 will flash
		↓			OFF	
	ENTER			OFF	OLS.A will turn off.	

**LEGEND FOR FIG. 63-65**

<b>ALM</b> — Alarm	<b>HGBP</b> — Hot Gas Bypass
<b>ALT</b> — Alert	<b>LWT</b> — Leaving Water Temperature
<b>CB</b> — Circuit Breaker	<b>MBB</b> — Main Base Board
<b>CLR</b> — Clear	<b>MLV</b> — Minimum Load Valve
<b>CPM</b> — Compressor Protection Module	<b>MM</b> — Low Ambient Temperature Head Pressure Control
<b>CWFS</b> — Chilled Water Flow Switch	<b>OAT</b> — Outdoor Air Temperature
<b>DPT</b> — Discharge Pressure and Temperature	<b>PMP</b> — Pump
<b>ECEXV</b> — Economizer Electronic Expansion Valve	<b>SGT</b> — Saturated Gas Temperature
<b>ECTA</b> — Economizer A Temp	<b>SHD</b> — Loadshed
<b>EMM</b> — Energy Management Module	<b>SPT</b> — Space Temperature
<b>EXV</b> — Electronic Expansion Valve	<b>TB</b> — Terminal Block
<b>FC</b> — Fuse	<b>UPC</b> — Universal Protocol Converter/BacNet Communications Option
<b>FIOP</b> — Factory-Installed Option	

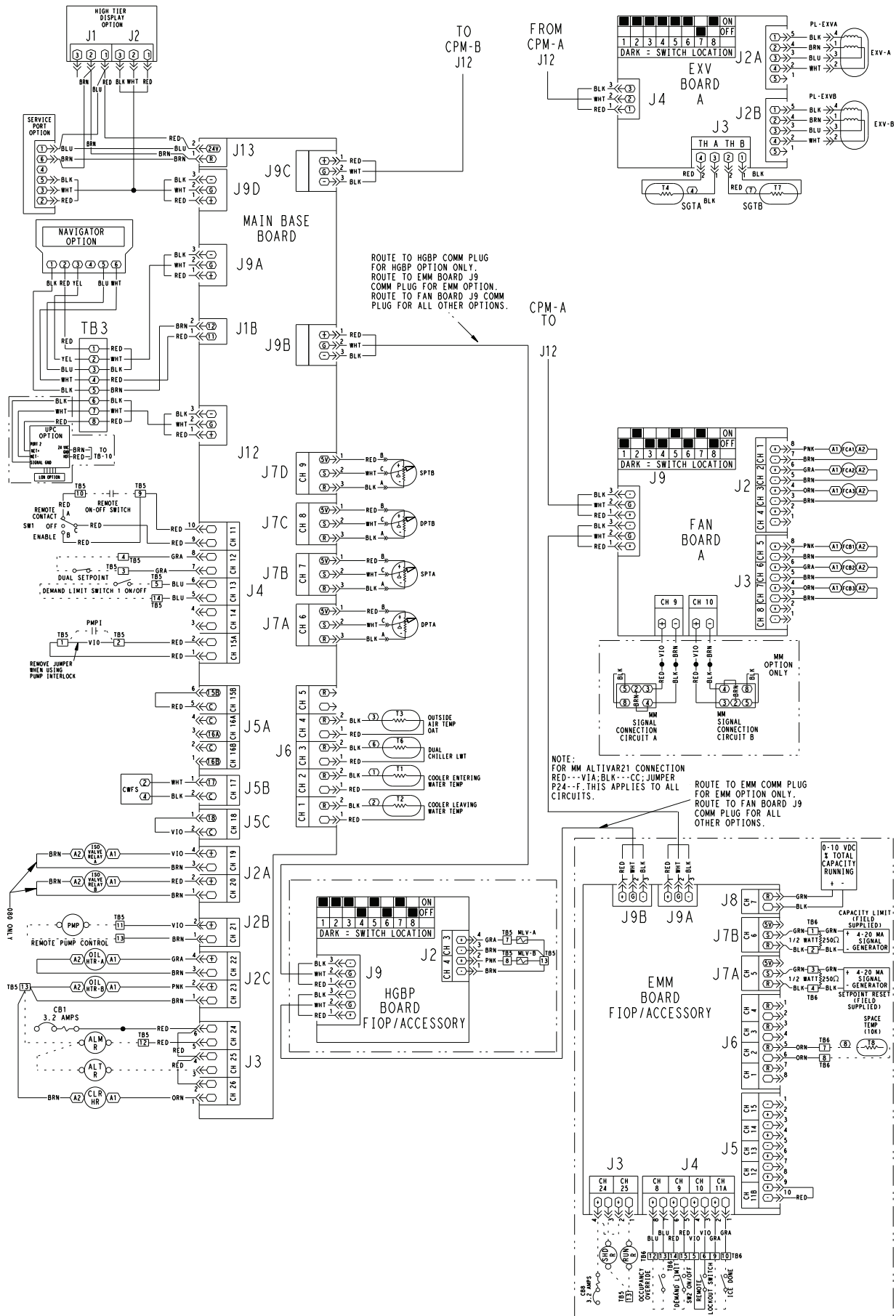


Fig. 63 — 30XA080,082 Low Voltage Control Schematic







## APPENDIX A — TOUCH PILOT DISPLAY TABLES

The Touch Pilot™ display tables are formatted in alphabetical order based on the point name description. The line number corresponds to the line number from the top the Touch Pilot screen. A cross reference to the CCN tables in Appendix C is provided. Please refer to Appendix C for range and configuration default information.

NOTE: In places where duplicated point name descriptions were used, the headers were added to the point name description to differentiate them. For example, the description 3 Way Valve Position is used three times for circuits A, B, and C. In this table, the descriptions include Circuit A, Circuit B, and Circuit C.

TOUCH PILOT DESCRIPTION	TOUCH PILOT POINT NAME	TOUCH PILOT PATH	LINE	READ/ WRITE	CCN TABLE NAME
1 Elec Stage for backup	ehs_back	MAIN MENU\Config\USER	35	RW	Configuration Tables\USER
3 Way Valve Position	Q_3W_VLV	MAIN MENU>Status\QCK_TST2	11	RW	Status Display Tables\QCK_TST2
3 Way Valve Position					
Circuit A	fc_vlv_a	MAIN MENU>Status\FREECOOL	14	RO	Status Display Tables\FREECOOL
Circuit B	fc_vlv_b	MAIN MENU>Status\FREECOOL	24	RO	Status Display Tables\FREECOOL
Circuit C	fc_vlv_c	MAIN MENU>Status\FREECOOL	34	RO	Status Display Tables\FREECOOL
3 Way Valve Status					
Circuit A	FC_VLV_A	MAIN MENU>Status\FREECOOL	15	RO	Status Display Tables\FREECOOL
Circuit B	FC_VLV_B	MAIN MENU>Status\FREECOOL	25	RO	Status Display Tables\FREECOOL
Circuit C	FC_VLV_C	MAIN MENU>Status\FREECOOL	35	RO	Status Display Tables\FREECOOL
4 way Valve Circuit A	Q_RV_A	MAIN MENU>Status\QCK_TST2	13	RW	Status Display Tables\QCK_TST2
4 way Valve Circuit B	Q_RV_B	MAIN MENU>Status\QCK_TST2	14	RW	Status Display Tables\QCK_TST2
4 Way Refrigerant Valve					
Circuit A	RV_A	MAIN MENU>Status\CIRCA_D	24	RO	Status Display Tables\CIRCA_D
Circuit B	RV_B	MAIN MENU>Status\CIRCB_D	24	RO	Status Display Tables\CIRCB_D
Circuit C	RV_C	MAIN MENU>Status\CIRCC_D	23	RO	Status Display Tables\CIRCC_D
Activate	ccnbroad	MAIN MENU\Config\BRODEFS	1	RW	Configuration Tables\BRODEFS\BROCASTS
Active Capacity Override	over_cap	MAIN MENU\Maint\LOADFACT	20	RO	Maintenance Display Tables\LOADFACT
Active Demand Limit Val	DEM_LIM	MAIN MENU>Status\GENUNIT	21	RO	Status Display Tables\GENUNIT
Actual Capacity	cap_t	MAIN MENU\Maint\LOADFACT	8	RO	Maintenance Display Tables\LOADFACT
Actual Capacity Limit	cap_lim	MAIN MENU\Maint\LOADFACT	9	RO	Maintenance Display Tables\LOADFACT
Actual Chiller Current	TOT_CURR	MAIN MENU\Maint\LOADFACT	10	RO	Maintenance Display Tables\LOADFACT
Actual Chiller Current	TOT_CURR	MAIN MENU>Status\GENUNIT	23	RO	Status Display Tables\GENUNIT
Air Cond Enter Valve A	Q_HREA_A	MAIN MENU>Status\QCK_TST2	3	RW	Status Display Tables\QCK_TST2
Air Cond Enter Valve B	Q_HREA_B	MAIN MENU>Status\QCK_TST2	7	RW	Status Display Tables\QCK_TST2
Air Cond Entering Valv A	hr_ea_a	MAIN MENU>Status\RECLAIM	15	RO	Status Display Tables\RECLAIM
Air Cond Entering Valv B	hr_ea_b	MAIN MENU>Status\RECLAIM	25	RO	Status Display Tables\RECLAIM
Air Cond Leaving Valv A	Q_HRLA_A	MAIN MENU>Status\QCK_TST2	4	RW	Status Display Tables\QCK_TST2
Air Cond Leaving Valv B	Q_HRLA_B	MAIN MENU>Status\QCK_TST2	8	RW	Status Display Tables\QCK_TST2
Air Cond Leaving Valve A	hr_la_a	MAIN MENU>Status\RECLAIM	17	RO	Status Display Tables\RECLAIM
Air Cond Leaving Valve B	hr_la_b	MAIN MENU>Status\RECLAIM	27	RO	Status Display Tables\RECLAIM
Air Cooled Reclaim Sel	recl_opt	MAIN MENU\Service\FACTORY	10	RW	Service Configuration Tables\FACTORY
Alarm Equipment Priority	EQP_TYP	MAIN MENU\Config\ALARMDEF	2	RW	Configuration Tables\ALARMDEF\ALARMS01
Alarm Relay Output	Q_ALARM	MAIN MENU>Status\QCK_TST1	48	RW	Status Display Tables\QCK_TST1
Alarm Relay Status	ALARMOUT	MAIN MENU>Status\STATEGEN	28	RO	Status Display Tables\STATEGEN
Alarm Routing Control	ALRM_CNT	MAIN MENU\Config\ALARMDEF	1	RW	Configuration Tables\ALARMDEF\ALARMS01
Alarm State	ALM	MAIN MENU>Status\GENUNIT	13	RO	Status Display Tables\GENUNIT
Alarm System Name	ALRM_NAM	MAIN MENU\Config\ALARMDEF	5	RW	Configuration Tables\ALARMDEF\ALARMS01
Alert Relay Output	Q_ALERT	MAIN MENU>Status\QCK_TST1	49	RW	Status Display Tables\QCK_TST1
Alert Relay Status	ALERT	MAIN MENU>Status\STATEGEN	29	RO	Status Display Tables\STATEGEN
Auto Changeover Active	Mode_12	MAIN MENU>Status\MODES	13	RO	Status Display Tables\MODES
Auto Changeover Select	auto_sel	MAIN MENU\Config\USER	18	RW	Configuration Tables\USER
Auto Start When SM Lost	auto_sm	MAIN MENU\Service\SERVICE1	18	RW	Service Configuration Tables\SERVICE1
AUX Board #1 Part Number	AUX_BRD1	MAIN MENU\Maint\BOARD_PN	4	RO	Maintenance Display Tables\BOARD_PN
AUX Board #2 Part Number	AUX_BRD2	MAIN MENU\Maint\BOARD_PN	5	RO	Maintenance Display Tables\BOARD_PN
AUX Board #3 Part Number	AUX_BRD3	MAIN MENU\Maint\BOARD_PN	6	RO	Maintenance Display Tables\BOARD_PN
AUX Board #4 Part Number	AUX_BRD4	MAIN MENU\Maint\BOARD_PN	7	RO	Maintenance Display Tables\BOARD_PN
AUX Board #5 Part Number	AUX_BRD5	MAIN MENU\Maint\BOARD_PN	8	RO	Maintenance Display Tables\BOARD_PN
Average Ctrl Water Temp	ctrl_avg	MAIN MENU\Maint\LOADFACT	2	RO	Maintenance Display Tables\LOADFACT

### LEGEND

RO — Read Only  
RW — Read/Write

**APPENDIX A — TOUCH PILOT™ DISPLAY TABLES (cont)**

TOUCH PILOT DESCRIPTION	TOUCH PILOT POINT NAME	TOUCH PILOT PATH	LINE	READ/ WRITE	CCN TABLE NAME
<b>Ball Valve Closing Out</b>					
Circuit A	ISO_CL_A	MAIN MENU\Status\CIRCA_D	22	RO	Status Display Tables\CIRCA_D
Circuit B	ISO_CL_B	MAIN MENU\Status\CIRCB_D	22	RO	Status Display Tables\CIRCB_D
Circuit C	ISO_CL_C	MAIN MENU\Status\CIRCC_D	22	RO	Status Display Tables\CIRCC_D
<b>Ball Valve Opening Out</b>					
Circuit A	ISO_OP_A	MAIN MENU\Status\CIRCA_D	23	RO	Status Display Tables\CIRCA_D
Circuit B	ISO_OP_B	MAIN MENU\Status\CIRCB_D	23	RO	Status Display Tables\CIRCB_D
Circuit C	ISO_OP_C	MAIN MENU\Status\CIRCC_D	23	RO	Status Display Tables\CIRCC_D
<b>Ball Valve Position</b>					
Circuit A	ISO_REFA	MAIN MENU\Status\CIRCA_D	21	RO	Status Display Tables\CIRCA_D
Circuit B	ISO_REFB	MAIN MENU\Status\CIRCB_D	21	RO	Status Display Tables\CIRCB_D
Circuit C	ISO_REFC	MAIN MENU\Status\CIRCC_D	21	RO	Status Display Tables\CIRCC_D
<b>Baud rate</b>	Baud rate	MAIN MENU\Config\Ctr-ID	9	RO	Configuration Tables\CtrID\PD5_XAXQ
<b>Brine flow Switch SP</b>	flow_sp	MAIN MENU\Service\SERVICE1	2	RW	Service Configuration Tables\SERVICE1
<b>Brine Freeze Setpoint</b>	lowestsp	MAIN MENU\Service\SERVICE1	3	RW	Service Configuration Tables\SERVICE1
<b>Broadcast acknowledger</b>	Broadcast	MAIN MENU\Config\Ctr-ID	10	RO	Configuration Tables\CtrID\PD5_XAXQ
<b>Bus</b>	Bus	MAIN MENU\Config\Ctr-ID	7	RO	Configuration Tables\CtrID\PD5_XAXQ
<b>CCN Chiller Start/Stop</b>	CHIL_S_S	MAIN MENU\Status\GENUNIT	5	RO	Status Display Tables\GENUNIT
<b>Chiller Capacity in0-10v</b>	Q_CATO	MAIN MENU\Status\QCK_TST1	46	RW	Status Display Tables\QCK_TST1
<b>Chiller Capacity Signal</b>	CAPT_010	MAIN MENU\Status\STATEGEN	43	RO	Status Display Tables\STATEGEN
<b>Chiller Current Limit</b>	CURR_LIM	MAIN MENU\Maint\LOADFACT	11	RO	Maintenance Display Tables\LOADFACT
<b>Chiller Current Limit</b>	CURR_LIM	MAIN MENU\Status\GENUNIT	24	RW	Status Display Tables\GENUNIT
<b>Chiller in Series</b>	ll_serie	MAIN MENU\Config\MST_SLV	24	RW	Configuration Tables\MST_SLV
<b>Chiller Occupied?</b>	CHIL_OCC	MAIN MENU\Status\GENUNIT	6	RO	Status Display Tables\GENUNIT
<b>Chiller Ready Output</b>	Q_READY	MAIN MENU\Status\QCK_TST1	41	RW	Status Display Tables\QCK_TST1
<b>Chiller Running Output</b>	Q_RUN	MAIN MENU\Status\QCK_TST1	42	RW	Status Display Tables\QCK_TST1
<b>CHWS Temperature</b>	CHWSTEMP	MAIN MENU\Status\STATEGEN	40	RO	Status Display Tables\STATEGEN
<b>Circuit C Heater Temp</b>	T_HEAT_C	MAIN MENU\Status\STATEGEN	38	RO	Status Display Tables\STATEGEN
<b>Circuit Loading Sequence</b>	lead_cir	MAIN MENU\Config\USER	1	RW	Configuration Tables\USER
<b>Comm Failure Retry Time</b>	RETRY_TM	MAIN MENU\Config\ALARMDEF	3	RW	Configuration Tables\ALARMDEF\ALARMS01
<b>Comp A Must Trip Amps</b>	cpa_mtac	MAIN MENU\Service\FACTORY2	2	RW	Service Configuration Tables\FACTORY2
<b>Comp A S1 Config Switch (8-&gt;1)</b>	cpa_s1_c	MAIN MENU\Service\FACTORY2	3	RW	Service Configuration Tables\FACTORY2
<b>Comp B Must Trip Amps</b>	cpb_mtac	MAIN MENU\Service\FACTORY2	6	RW	Service Configuration Tables\FACTORY2
<b>Comp B S1 Config Switch (8-&gt;1)</b>	cpb_s1_c	MAIN MENU\Service\FACTORY2	7	RW	Service Configuration Tables\FACTORY2
<b>Comp C Must Trip Amps</b>	cpc_mtac	MAIN MENU\Service\FACTORY2	10	RW	Service Configuration Tables\FACTORY2
<b>Comp C S1 Config Switch (8-&gt;1)</b>	cpc_s1_c	MAIN MENU\Service\FACTORY2	11	RW	Service Configuration Tables\FACTORY2
<b>Compressor A Disable</b>	un_cp_a	MAIN MENU\Service\CP_UNABL	2	RW	Service Configuration\CP_UNABL
<b>Compressor A Hours</b>	hr_cp_a	MAIN MENU\Service\UPDTHOUR	7	RW	Service Configuration Tables\UPDTHOUR
<b>Compressor A Hours</b>	HR_CP_A	MAIN MENU\Status\STRTHOUR	3	RO	Status Display Tables\STRTHOUR
<b>Compressor A Output</b>	Q_CPA	MAIN MENU\Status\SERV_TST	3	RW	Status Display Tables\SERV_TST
<b>Compressor A Starts</b>	st_cp_a	MAIN MENU\Service\UPDTHOUR	8	RW	Service Configuration Tables\UPDTHOUR
<b>Compressor A Starts</b>	st_cp_a	MAIN MENU\Status\STRTHOUR	4	RO	Status Display Tables\STRTHOUR
<b>Compressor B Disable</b>	un_cp_b	MAIN MENU\Service\CP_UNABL	3	RW	Service Configuration\CP_UNABL
<b>Compressor B Hours</b>	hr_cp_b	MAIN MENU\Service\UPDTHOUR	9	RW	Service Configuration Tables\UPDTHOUR
<b>Compressor B Hours</b>	HR_CP_B	MAIN MENU\Status\STRTHOUR	5	RO	Status Display Tables\STRTHOUR
<b>Compressor B Output</b>	Q_CPB	MAIN MENU\Status\SERV_TST	5	RW	Status Display Tables\SERV_TST
<b>Compressor B Starts</b>	st_cp_b	MAIN MENU\Service\UPDTHOUR	10	RW	Service Configuration Tables\UPDTHOUR
<b>Compressor B Starts</b>	st_cp_b	MAIN MENU\Status\STRTHOUR	6	RO	Status Display Tables\STRTHOUR
<b>Compressor C Disable</b>	un_cp_c	MAIN MENU\Service\CP_UNABL	4	RW	Service Configuration\CP_UNABL
<b>Compressor C Hours</b>	hr_cp_c	MAIN MENU\Service\UPDTHOUR	11	RW	Service Configuration Tables\UPDTHOUR
<b>Compressor C Hours</b>	HR_CP_C	MAIN MENU\Status\STRTHOUR	7	RO	Status Display Tables\STRTHOUR
<b>Compressor C Output</b>	Q_CPC	MAIN MENU\Status\SERV_TST	7	RW	Status Display Tables\SERV_TST
<b>Compressor C Starts</b>	st_cp_c	MAIN MENU\Service\UPDTHOUR	12	RW	Service Configuration Tables\UPDTHOUR
<b>Compressor C Starts</b>	st_cp_c	MAIN MENU\Status\STRTHOUR	8	RO	Status Display Tables\STRTHOUR

LEGEND

RO — Read Only  
RW — Read/Write

**APPENDIX A — TOUCH PILOT™ DISPLAY TABLES (cont)**

TOUCH PILOT DESCRIPTION	TOUCH PILOT POINT NAME	TOUCH PILOT PATH	LINE	READ/ WRITE	CCN TABLE NAME
<b>Compressor Output</b>					
Circuit A	COMP_A	MAIN MENU\Status\CIRCA_D	2	RO	Status Display Tables\CIRCA_D
Circuit B	COMP_B	MAIN MENU\Status\CIRCB_D	2	RO	Status Display Tables\CIRCB_D
Circuit C	COMP_C	MAIN MENU\Status\CIRCC_D	2	RO	Status Display Tables\CIRCC_D
<b>Compressor Suction Temp</b>					
Circuit A	SUCT_T_A	MAIN MENU\Status\CIRCA_AN	14	RO	Status Display Tables\CIRCA_AN
Circuit B	SUCT_T_B	MAIN MENU\Status\CIRCB_AN	14	RO	Status Display Tables\CIRCB_AN
Circuit C	SUCT_T_C	MAIN MENU\Status\CIRCC_AN	14	RO	Status Display Tables\CIRCC_AN
<b>Condenser Entering Fluid</b>	COND_EWT	MAIN MENU\Status\STATEGEN	35	RO	Status Display Tables\STATEGEN
<b>Condenser Flow Status</b>	CONDFLOW	MAIN MENU\Status\STATEGEN	14	RO	Status Display Tables\STATEGEN
<b>Condenser Fluid Type</b>	cond_typ	MAIN MENU\Service\SERVICE1	4	RW	Service Configuration Tables\SERVICE1
<b>Condenser Leaving Fluid</b>	COND_LWT	MAIN MENU\Status\STATEGEN	36	RO	Status Display Tables\STATEGEN
<b>Condenser Probe Select</b>	condprob	MAIN MENU\Service\FACTORY	26	RW	Service Configuration Tables\FACTORY
<b>Condenser Pump #1 Command</b>	HPUMP_1	MAIN MENU\Status\STATEGEN	23	RO	Status Display Tables\STATEGEN
<b>Condenser Pump #1 Hours</b>	hr_hpum1	MAIN MENU\Service\UPDTHOUR	15	RW	Service Configuration Tables\UPDTHOUR
<b>Condenser Pump #1 Hours</b>	hr_hpum1	MAIN MENU\Status\STRTHOUR	11	RO	Status Display Tables\STRTHOUR
<b>Condenser Pump #2 Command</b>	HPUMP_2	MAIN MENU\Status\STATEGEN	24	RO	Status Display Tables\STATEGEN
<b>Condenser Pump #2 Hours</b>	hr_hpum2	MAIN MENU\Service\UPDTHOUR	16	RW	Service Configuration Tables\UPDTHOUR
<b>Condenser Pump #2 Hours</b>	hr_hpum2	MAIN MENU\Status\STRTHOUR	12	RO	Status Display Tables\STRTHOUR
<b>Condenser Pump 1</b>	Q_HPMP1	MAIN MENU\Status\QCK_TST1	39	RW	Status Display Tables\QCK_TST1
<b>Condenser Pump 2</b>	Q_HPMP2	MAIN MENU\Status\QCK_TST1	40	RW	Status Display Tables\QCK_TST1
<b>Condenser Pumps Rotation</b>	Mode_17	MAIN MENU\Status\MODES	18	RO	Status Display Tables\MODES
<b>Condenser Pumps Sequence</b>	hpump_seq	MAIN MENU\Config\USER	7	RW	Configuration Tables\USER
<b>Condenser Water Val Sel</b>	cond_val	MAIN MENU\Service\FACTORY	13	RW	Service Configuration Tables\FACTORY
<b>Control Point</b>	CTRL_PNT	MAIN MENU\Maint\LOADFACT	5	RO	Maintenance Display Tables\LOADFACT
<b>Control Point</b>	CTRL_PNT	MAIN MENU\Status\GENUNIT	28	RO	Status Display Tables\GENUNIT
<b>Control Type</b>	ctr_type	MAIN MENU\Status\GENUNIT	3	RO	Status Display Tables\GENUNIT
<b>Controlled Temp Error</b>	tp_error	MAIN MENU\Maint\LOADFACT	7	RO	Maintenance Display Tables\LOADFACT
<b>Controlled Water Temp</b>	CTRL_WT	MAIN MENU\Status\GENUNIT	29	RO	Status Display Tables\GENUNIT
<b>Cool Changeover Setpt</b>	cauto_sp	MAIN MENU\Setpoint\SETPOINT	29	RW	Setpoint Configuration Tables\SETPOINT
<b>Cooler Entering Fluid</b>	COOL_EWT	MAIN MENU\Status\STATEGEN	33	RO	Status Display Tables\STATEGEN
<b>Cooler Entering Fluid</b>	COOL_EWT	MAIN MENU\Status\STATEGEN	33	RO	Status Display Tables\STATEGEN
<b>Cooler Exchange DT Cir A</b>	pinch_a	MAIN MENU\Maint\EXV_CTRL	6	RO	Maintenance Display Tables\EXV_CTRL
<b>Cooler Exchange DT Cir B</b>	pinch_b	MAIN MENU\Maint\EXV_CTRL	13	RO	Maintenance Display Tables\EXV_CTRL
<b>Cooler Exchange DT Cir C</b>	pinch_c	MAIN MENU\Maint\EXV_CTRL	20	RO	Maintenance Display Tables\EXV_CTRL
<b>Cooler Flow Setpoint Out</b>	SET_FLOW	MAIN MENU\Status\STATEGEN	18	RO	Status Display Tables\STATEGEN
<b>Cooler Flow Switch</b>	FLOW_SW	MAIN MENU\Status\STATEGEN	12	RO	Status Display Tables\STATEGEN
<b>Cooler Fluid Type</b>	flui_typ	MAIN MENU\Service\SERVICE1	1	RW	Service Configuration Tables\SERVICE1
<b>Cooler Heater Active</b>	Mode_06	MAIN MENU\Status\MODES	7	RO	Status Display Tables\MODES
<b>Cooler Heater Command</b>	COOLHEAT	MAIN MENU\Status\STATEGEN	26	RO	Status Display Tables\STATEGEN
<b>Cooler Heater Delta Spt</b>	heatersp	MAIN MENU\Service\SERVICE1	17	RW	Service Configuration Tables\SERVICE1
<b>Cooler Heater Output</b>	Q_CL_HT	MAIN MENU\Status\QCK_TST1	36	RW	Status Display Tables\QCK_TST1
<b>Cooler Heater Select</b>	heat_sel	MAIN MENU\Service\FACTORY	12	RW	Service Configuration Tables\FACTORY
<b>Cooler Heater Temp</b>	T_HEATER	MAIN MENU\Status\STATEGEN	37	RO	Status Display Tables\STATEGEN
<b>Cooler Leaving Fluid</b>	COOL_LWT	MAIN MENU\Status\STATEGEN	34	RO	Status Display Tables\STATEGEN
<b>Cooler Leaving Fluid</b>	COOL_LWT	MAIN MENU\Status\STATEGEN	34	RO	Status Display Tables\STATEGEN
<b>Cooler Pinch Ctl Point A</b>	pinch_spa	MAIN MENU\Maint\EXV_CTRL	7	RO	Maintenance Display Tables\EXV_CTRL
<b>Cooler Pinch Ctl Point B</b>	pinch_spb	MAIN MENU\Maint\EXV_CTRL	14	RO	Maintenance Display Tables\EXV_CTRL
<b>Cooler Pinch Ctl Point C</b>	pinch_spc	MAIN MENU\Maint\EXV_CTRL	21	RO	Maintenance Display Tables\EXV_CTRL
<b>Cooler Pump #1 Command</b>	CPUMP_1	MAIN MENU\Status\STATEGEN	20	RO	Status Display Tables\STATEGEN
<b>Cooler Pump #1 Hours</b>	hr_cpum1	MAIN MENU\Status\STRTHOUR	9	RO	Status Display Tables\STRTHOUR
<b>Cooler Pump #2 Command</b>	CPUMP_2	MAIN MENU\Status\STATEGEN	21	RO	Status Display Tables\STATEGEN
<b>Cooler Pump #2 Hours</b>	hr_cpum2	MAIN MENU\Status\STRTHOUR	10	RO	Status Display Tables\STRTHOUR

**LEGEND**

**RO** — Read Only  
**RW** — Read/Write

**APPENDIX A — TOUCH PILOT™ DISPLAY TABLES (cont)**

TOUCH PILOT DESCRIPTION	TOUCH PILOT POINT NAME	TOUCH PILOT PATH	LINE	READ/ WRITE	CCN TABLE NAME
Cooler Pump Run Status	CPUMPDEF	MAIN MENU\Status\STATEGEN	13	RO	Status Display Tables\STATEGEN
Cooler Pumps Rotation	Mode_07	MAIN MENU\Status\MODES	8	RO	Status Display Tables\MODES
Cooler Pumps Sequence	cpump_seq	MAIN MENU\Config\USER	8	RW	Configuration Tables\USER
Cooling Ice Setpoint	ice_sp	MAIN MENU\Setpoint\SETPOINT	4	RW	Setpoint Configuration Tables\SETPOINT
Cooling Ramp Loading	cramp_sp	MAIN MENU\Setpoint\SETPOINT	14	RW	Setpoint Configuration Tables\SETPOINT
Cooling Reset Deg. Value	cr_deg	MAIN MENU\Setpoint\SETPOINT	13	RW	Setpoint Configuration Tables\SETPOINT
Cooling Reset Select	cr_sel	MAIN MENU\Config\USER	19	RW	Configuration Tables\USER
Cooling Setpoint 1	csp1	MAIN MENU\Setpoint\SETPOINT	2	RW	Setpoint Configuration Tables\SETPOINT
Cooling Setpoint 2	csp2	MAIN MENU\Setpoint\SETPOINT	3	RW	Setpoint Configuration Tables\SETPOINT
Cooling/FreeCool Timeout	fc_tmout	MAIN MENU\Status\FREECOOL	7	RO	Status Display Tables\FREECOOL
CPump 1 Ctl Delay (days)	cpump1_c	MAIN MENU\Service\MAINTCFG	5	RW	Service Configuration Tables\MAINTCFG
CPump 2 Ctl Delay (days)	cpump2_c	MAIN MENU\Service\MAINTCFG	6	RW	Service Configuration Tables\MAINTCFG
Current Alarm 1	alarm_1	MAIN MENU\Status\GENUNIT	14	RO	Status Display Tables\GENUNIT
Current Alarm 2	alarm_2	MAIN MENU\Status\GENUNIT	15	RO	Status Display Tables\GENUNIT
Current Alarm 3	alarm_3	MAIN MENU\Status\GENUNIT	16	RO	Status Display Tables\GENUNIT
Current Alarm 4	alarm_4	MAIN MENU\Status\GENUNIT	17	RO	Status Display Tables\GENUNIT
Current Alarm 5	alarm_5	MAIN MENU\Status\GENUNIT	18	RO	Status Display Tables\GENUNIT
Current At 100% Load A	cur100_a	MAIN MENU\Maint\LOADFACT	15	RO	Maintenance Display Tables\LOADFACT
Current At 100% Load B	cur100_b	MAIN MENU\Maint\LOADFACT	16	RO	Maintenance Display Tables\LOADFACT
Current At 100% Load C	cur100_c	MAIN MENU\Maint\LOADFACT	17	RO	Maintenance Display Tables\LOADFACT
Current At 30% Load A	cur_30_a	MAIN MENU\Maint\LOADFACT	12	RO	Maintenance Display Tables\LOADFACT
Current At 30% Load B	cur_30_b	MAIN MENU\Maint\LOADFACT	13	RO	Maintenance Display Tables\LOADFACT
Current At 30% Load C	cur_30_c	MAIN MENU\Maint\LOADFACT	14	RO	Maintenance Display Tables\LOADFACT
Current Control	on_ctrl	MAIN MENU\Status\STATEGEN	4	RO	Status Display Tables\STATEGEN
Current Cooling Power	cool_pwr	MAIN MENU\Status\FREECOOL	4	RO	Status Display Tables\FREECOOL
Current Full Reset Value	v_cr_fu	MAIN MENU\Setpoint\SETPOINT	10	RW	Setpoint Configuration Tables\SETPOINT
Current Full Reset Value	v_hr_fu	MAIN MENU\Setpoint\SETPOINT	24	RW	Setpoint Configuration Tables\SETPOINT
Current Limit at 100%	curr_ful	MAIN MENU\Config\USER	31	RW	Configuration Tables\USER
Current Limit Select	curr_sel	MAIN MENU\Config\USER	30	RW	Configuration Tables\USER
Current Mode (1=occup.)	MODE	MAIN MENU\Maint\OCCDEFM\OCC1PO1S	1	RO	Maintenance Display Tables\OCCDEFM\OCC1PO1S
Current Mode (1=occup.)	MODE	MAIN MENU\Maint\OCCDEFM\OCC2PO2S	1	RO	Maintenance Display Tables\OCCDEFM\OCC2PO2S
Current No Reset Value	v_cr_no	MAIN MENU\Setpoint\SETPOINT	9	RW	Setpoint Configuration Tables\SETPOINT
Current No Reset Value	v_hr_no	MAIN MENU\Setpoint\SETPOINT	23	RW	Setpoint Configuration Tables\SETPOINT
Current Occup Period #	PER-NO	MAIN MENU\Maint\OCCDEFM\OCC1PO1S	2	RO	Maintenance Display Tables\OCCDEFM\OCC1PO1S
Current Occup Period #	PER-NO	MAIN MENU\Maint\OCCDEFM\OCC2PO2S	2	RO	Maintenance Display Tables\OCCDEFM\OCC2PO2S
Current Occupied Time	STRTTIME	MAIN MENU\Maint\OCCDEFM\OCC1PO1S	5	RO	Maintenance Display Tables\OCCDEFM\OCC1PO1S
Current Occupied Time	STRTTIME	MAIN MENU\Maint\OCCDEFM\OCC2PO2S	5	RO	Maintenance Display Tables\OCCDEFM\OCC2PO2S
Current Phase 1 Comp A	cpa_cur1	MAIN MENU\Maint\CUR_PHAS	1	RO	Maintenance Display Tables\CUR_PHASE
Current Phase 1 Comp B	cpb_cur1	MAIN MENU\Maint\CUR_PHAS	4	RO	Maintenance Display Tables\CUR_PHASE
Current Phase 1 Comp C	cpc_cur1	MAIN MENU\Maint\CUR_PHAS	7	RO	Maintenance Display Tables\CUR_PHASE
Current Phase 2 Comp A	cpa_cur2	MAIN MENU\Maint\CUR_PHAS	2	RO	Maintenance Display Tables\CUR_PHASE
Current Phase 2 Comp B	cpb_cur2	MAIN MENU\Maint\CUR_PHAS	5	RO	Maintenance Display Tables\CUR_PHASE
Current Phase 2 Comp C	cpc_cur2	MAIN MENU\Maint\CUR_PHAS	8	RO	Maintenance Display Tables\CUR_PHASE
Current Phase 3 Comp A	cpa_cur3	MAIN MENU\Maint\CUR_PHAS	3	RO	Maintenance Display Tables\CUR_PHASE
Current Phase 3 Comp B	cpb_cur3	MAIN MENU\Maint\CUR_PHAS	6	RO	Maintenance Display Tables\CUR_PHASE
Current Phase 3 Comp C	cpc_cur3	MAIN MENU\Maint\CUR_PHAS	9	RO	Maintenance Display Tables\CUR_PHASE

LEGEND

RO — Read Only  
RW — Read/Write

**APPENDIX A — TOUCH PILOT™ DISPLAY TABLES (cont)**

TOUCH PILOT DESCRIPTION	TOUCH PILOT POINT NAME	TOUCH PILOT PATH	LINE	READ/ WRITE	CCN TABLE NAME
Current Setpoint	SP	MAIN MENU\Status\GENUNIT	31	RW	Status Display Tables\GENUNIT
Current Unoccupied Time	ENDTIME	MAIN MENU\Maint\OCCDEFCM\OCC1PO1S	6	RO	Maintenance Display Tables\OCCDEFCM\OCC1PO1S
Current Unoccupied Time	ENDTIME	MAIN MENU\Maint\OCCDEFCM\OCC2PO2S	6	RO	Maintenance Display Tables\OCCDEFCM\OCC2PO2S
Current Z Multiplier Val	zm	MAIN MENU\Maint\LOADFACT	18	RO	Maintenance Display Tables\LOADFACT
Customer Shutdown Out	Q_SHUT	MAIN MENU\Status\QCK_TST1	47	RW	Status Display Tables\QCK_TST1
Daylight Sav Ent Day of Week (1=Monday)	startdow	MAIN MENU\Config\BRODEFS	10	RW	Configuration Tables\BRODEFS\BROCASTS
Daylight Sav Ent Month	startmon	MAIN MENU\Config\BRODEFS	9	RW	Configuration Tables\BRODEFS\BROCASTS
Daylight Sav Ent Week of Month	startwom	MAIN MENU\Config\BRODEFS	11	RW	Configuration Tables\BRODEFS\BROCASTS
Daylight Sav Leaving Day of Week (1=Monday)	stopdow	MAIN MENU\Config\BRODEFS	14	RW	Configuration Tables\BRODEFS\BROCASTS
Daylight Sav Leaving Month	stopmon	MAIN MENU\Config\BRODEFS	13	RW	Configuration Tables\BRODEFS\BROCASTS
Daylight Sav Leaving Week of Month	stopwom	MAIN MENU\Config\BRODEFS	15	RW	Configuration Tables\BRODEFS\BROCASTS
Daylight Saving Select	dayl_sel	MAIN MENU\Config\BRODEFS	7	RW	Configuration Tables\BRODEFS\BROCASTS
Decription	DevDesc	MAIN MENU\Config\CtrID	1	RW	Configuration Tables\CtrID\PD5_XAXQ
Defrost Active On Cir A	Mode_19	MAIN MENU\Status\MODES	20	RO	Status Display Tables\MODES
Defrost Active On Cir B	Mode_20	MAIN MENU\Status\MODES	21	RO	Status Display Tables\MODES
Defrost Active?					
Circuit A	mode[19]	MAIN MENU\Maint\DEFROSTM	4	RO	Maintenance Display Tables\DEFROSTM
Circuit B	mode[20]	MAIN MENU\Maint\DEFROSTM	21	RO	Maintenance Display Tables\DEFROSTM
Defrost Duration					
Circuit A	defr_dua	MAIN MENU\Maint\DEFROSTM	6	RO	Maintenance Display Tables\DEFROSTM
Circuit B	defr_dub	MAIN MENU\Maint\DEFROSTM	23	RO	Maintenance Display Tables\DEFROSTM
Defrost Fan Offset Cal A	def_of_a	MAIN MENU\Maint\DEFROSTM	16	RO	Maintenance Display Tables\DEFROSTM
Defrost Fan Offset Cal B	def_of_b	MAIN MENU\Maint\DEFROSTM	33	RO	Maintenance Display Tables\DEFROSTM
Defrost Fan Start Cal A	def_ca_a	MAIN MENU\Maint\DEFROSTM	15	RO	Maintenance Display Tables\DEFROSTM
Defrost Fan Start Cal B	def_ca_b	MAIN MENU\Maint\DEFROSTM	32	RO	Maintenance Display Tables\DEFROSTM
Defrost Number					
Circuit A	nb_def_a	MAIN MENU\Service\UPDHRFAN	6	RW	Service Configuration Tables\UPDHRFAN
Circuit B	nb_def_b	MAIN MENU\Service\UPDHRFAN	7	RW	Service Configuration Tables\UPDHRFAN
Defrost Number					
Circuit A	nb_def_a	MAIN MENU\Status\FANHOURS	3	RO	Status Display Tables\FANHOURS
Circuit B	nb_def_b	MAIN MENU\Status\FANHOURS	4	RO	Status Display Tables\FANHOURS
Defrost Temperature					
Circuit A	DEFRT_A	MAIN MENU\Maint\DEFROSTM	5	RO	Maintenance Display Tables\DEFROSTM
Circuit B	DEFRT_B	MAIN MENU\Maint\DEFROSTM	22	RO	Maintenance Display Tables\DEFROSTM
Delta - Reference Delta					
Circuit A	delt_v_a	MAIN MENU\Maint\DEFROSTM	13	RO	Maintenance Display Tables\DEFROSTM
Circuit B	delt_v_b	MAIN MENU\Maint\DEFROSTM	30	RO	Maintenance Display Tables\DEFROSTM
Delta: OAT - Mean SST					
Circuit A	delt_a	MAIN MENU\Maint\DEFROSTM	11	RO	Maintenance Display Tables\DEFROSTM
Circuit B	delt_b	MAIN MENU\Maint\DEFROSTM	28	RO	Maintenance Display Tables\DEFROSTM
Delta T Full Reset Value	dt_cr_fu	MAIN MENU\Setpoint\SETPOINT	8	RW	Setpoint Configuration Tables\SETPOINT
Delta T Full Reset Value	dt_hr_fu	MAIN MENU\Setpoint\SETPOINT	22	RW	Setpoint Configuration Tables\SETPOINT
Delta T No Reset Value	dt_cr_no	MAIN MENU\Setpoint\SETPOINT	7	RW	Setpoint Configuration Tables\SETPOINT
Delta T No Reset Value	dt_hr_no	MAIN MENU\Setpoint\SETPOINT	21	RW	Setpoint Configuration Tables\SETPOINT
Demand Limit Active	Mode_04	MAIN MENU\Status\MODES	5	RO	Status Display Tables\MODES
Demand Limit Type Select	lim_sel	MAIN MENU\Config\USER	24	RW	Configuration Tables\USER
Deri PID Gain Varifan	hd_dg	MAIN MENU\Service\SERVICE1	8	RW	Service Configuration Tables\SERVICE1
DGT Cool Solenoid					
Circuit A	Q_CDGT_A	MAIN MENU\Status\QCK_TST1	21	RW	Status Display Tables\QCK_TST1
Circuit B	Q_CDGT_B	MAIN MENU\Status\QCK_TST1	28	RW	Status Display Tables\QCK_TST1

LEGEND

RO — Read Only  
RW — Read/Write

**APPENDIX A — TOUCH PILOT™ DISPLAY TABLES (cont)**

TOUCH PILOT DESCRIPTION	TOUCH PILOT POINT NAME	TOUCH PILOT PATH	LINE	READ/ WRITE	CCN TABLE NAME
<b>DGT Cooling Solenoid</b>					
Circuit A	GASCOOLA	MAIN MENU\Status\CIRCA_D	8	RO	Status Display Tables\CIRCA_D
Circuit B	GASCOOLB	MAIN MENU\Status\CIRCB_D	8	RO	Status Display Tables\CIRCB_D
Circuit C	GASCOOLC	MAIN MENU\Status\CIRCC_D	8	RO	Status Display Tables\CIRCC_D
<b>Discharge Gas Temp</b>					
Circuit A	DGT_A	MAIN MENU\Status\CIRCA_AN	10	RO	Status Display Tables\CIRCA_AN
Circuit B	DGT_B	MAIN MENU\Status\CIRCB_AN	10	RO	Status Display Tables\CIRCB_AN
Circuit C	DGT_C	MAIN MENU\Status\CIRCC_AN	10	RO	Status Display Tables\CIRCC_AN
<b>Discharge Pressure</b>					
Circuit A	DP_A	MAIN MENU\Status\CIRCA_AN	3	RO	Status Display Tables\CIRCA_AN
Circuit B	DP_B	MAIN MENU\Status\CIRCB_AN	3	RO	Status Display Tables\CIRCB_AN
Circuit C	DP_C	MAIN MENU\Status\CIRCC_AN	3	RO	Status Display Tables\CIRCC_AN
<b>Differential Water Temp</b>	diff_wt	MAIN MENU\Maint\LOADFACT	3	RO	Maintenance Display Tables\LOADFACT
<b>Discharge A Gas Limit</b>	sdtlim_a	MAIN MENU\Maint\PR_LIMIT	3	RO	Maintenance Display Tables\PR_LIMIT
<b>Discharge A Temp Average</b>	sdt_m_a	MAIN MENU\Maint\PR_LIMIT	1	RO	Maintenance Display Tables\PR_LIMIT
<b>Discharge A Temp Rate</b>	sdt_mr_a	MAIN MENU\Maint\PR_LIMIT	2	RO	Maintenance Display Tables\PR_LIMIT
<b>Discharge B Gas Limit</b>	sdtlim_b	MAIN MENU\Maint\PR_LIMIT	7	RO	Maintenance Display Tables\PR_LIMIT
<b>Discharge B Temp Average</b>	sdt_m_b	MAIN MENU\Maint\PR_LIMIT	5	RO	Maintenance Display Tables\PR_LIMIT
<b>Discharge B Temp Rate</b>	sdt_mr_b	MAIN MENU\Maint\PR_LIMIT	6	RO	Maintenance Display Tables\PR_LIMIT
<b>Discharge C Gas Limit</b>	sdtlim_c	MAIN MENU\Maint\PR_LIMIT	11	RO	Maintenance Display Tables\PR_LIMIT
<b>Discharge C Temp Average</b>	sdt_m_c	MAIN MENU\Maint\PR_LIMIT	9	RO	Maintenance Display Tables\PR_LIMIT
<b>Discharge C Temp Rate</b>	sdt_mr_c	MAIN MENU\Maint\PR_LIMIT	10	RO	Maintenance Display Tables\PR_LIMIT
<b>Discharge Superheat A</b>	DSH_A	MAIN MENU\Maint\EXV_CTRL	3	RO	Maintenance Display Tables\EXV_CTRL
<b>Discharge Superheat B</b>	DSH_B	MAIN MENU\Maint\EXV_CTRL	10	RO	Maintenance Display Tables\EXV_CTRL
<b>Discharge Superheat C</b>	DSH_C	MAIN MENU\Maint\EXV_CTRL	17	RO	Maintenance Display Tables\EXV_CTRL
<b>DLY 3 - Cooler Pump 1 (days)</b>	cpump1_m	MAIN MENU\Maint\SERMAINT	10	RO	Maintenance Display Tables\SERMAINT
<b>DLY 4 - Cooler Pump 2 (days)</b>	cpump2_m	MAIN MENU\Maint\SERMAINT	11	RO	Maintenance Display Tables\SERMAINT
<b>DLY 5 - Condenser Pump 1 (days)</b>	hpump1_m	MAIN MENU\Maint\SERMAINT	12	RO	Maintenance Display Tables\SERMAINT
<b>DLY 6 - Condenser Pump 2 (days)</b>	hpump2_m	MAIN MENU\Maint\SERMAINT	13	RO	Maintenance Display Tables\SERMAINT
<b>DLY 7 - Water Filter (days)</b>	wfilte_m	MAIN MENU\Maint\SERMAINT	14	RO	Maintenance Display Tables\SERMAINT
<b>DLY 8 - Cp A Oil Filter (days)</b>	ofilta_m	MAIN MENU\Maint\SERMAINT	15	RO	Maintenance Display Tables\SERMAINT
<b>DLY 9 - Cp B Oil Filter (days)</b>	ofiltb_m	MAIN MENU\Maint\SERMAINT	16	RO	Maintenance Display Tables\SERMAINT
<b>DLY 10 - Cp C Oil Filter (days)</b>	ofiltc_m	MAIN MENU\Maint\SERMAINT	17	RO	Maintenance Display Tables\SERMAINT
<b>DX Cooler Select</b>	dxcooler	MAIN MENU\Service\FACTORY	16	RW	Service Configuration Tables\FACTORY
<b>Economizer A Steps Numb</b>	eco_cnfa	MAIN MENU\Service\FACTORY2	22	RW	Service Configuration Tables\FACTORY2
<b>Economizer B Steps Numb</b>	eco_cnfb	MAIN MENU\Service\FACTORY2	23	RW	Service Configuration Tables\FACTORY2
<b>Economizer C Steps Numb</b>	eco_cnfc	MAIN MENU\Service\FACTORY2	24	RW	Service Configuration Tables\FACTORY2
<b>Economizer Position A</b>	EXV_EC_A	MAIN MENU\Maint\EXV_CTRL	25	RO	Maintenance Display Tables\EXV_CTRL
<b>Economizer Position B</b>	EXV_EC_B	MAIN MENU\Maint\EXV_CTRL	29	RO	Maintenance Display Tables\EXV_CTRL
<b>Economizer Position C</b>	EXV_EC_C	MAIN MENU\Maint\EXV_CTRL	33	RO	Maintenance Display Tables\EXV_CTRL
<b>Economizer SH Setpoint A</b>	ecsh_spa	MAIN MENU\Maint\EXV_CTRL	27	RO	Maintenance Display Tables\EXV_CTRL
<b>Economizer SH Setpoint A</b>	esh_sp_a	MAIN MENU\Service\SERVICE1	21	RW	Service Configuration Tables\SERVICE1
<b>Economizer SH Setpoint B</b>	ecsh_spb	MAIN MENU\Maint\EXV_CTRL	31	RO	Maintenance Display Tables\EXV_CTRL
<b>Economizer SH Setpoint B</b>	esh_sp_b	MAIN MENU\Service\SERVICE1	22	RW	Service Configuration Tables\SERVICE1
<b>Economizer SH Setpoint C</b>	ecsh_spc	MAIN MENU\Maint\EXV_CTRL	35	RO	Maintenance Display Tables\EXV_CTRL
<b>Economizer SH Setpoint C</b>	esh_sp_c	MAIN MENU\Service\SERVICE1	23	RW	Service Configuration Tables\SERVICE1
<b>Economizer Superheat A</b>	eco_sha	MAIN MENU\Maint\EXV_CTRL	26	RO	Maintenance Display Tables\EXV_CTRL
<b>Economizer Superheat B</b>	eco_shb	MAIN MENU\Maint\EXV_CTRL	30	RO	Maintenance Display Tables\EXV_CTRL
<b>Economizer Superheat C</b>	eco_shc	MAIN MENU\Maint\EXV_CTRL	34	RO	Maintenance Display Tables\EXV_CTRL
<b>Economizer EXV Pos</b>					
Circuit A	Q_ECO_A	MAIN MENU\Status\QCK_TST1	6	RW	Status Display Tables\QCK_TST1
Circuit B	Q_ECO_B	MAIN MENU\Status\QCK_TST1	7	RW	Status Display Tables\QCK_TST1
Circuit C	Q_ECO_C	MAIN MENU\Status\QCK_TST1	8	RW	Status Display Tables\QCK_TST1

**LEGEND**

**RO** — Read Only  
**RW** — Read/Write

**APPENDIX A — TOUCH PILOT™ DISPLAY TABLES (cont)**

TOUCH PILOT DESCRIPTION	TOUCH PILOT POINT NAME	TOUCH PILOT PATH	LINE	READ/ WRITE	CCN TABLE NAME
<b>Economizer Gas Temp</b>					
Circuit A	ECO_TP_A	MAIN MENU\Status\CIRCA_AN	11	RO	Status Display Tables\CIRCA_AN
Circuit B	ECO_TP_B	MAIN MENU\Status\CIRCB_AN	11	RO	Status Display Tables\CIRCB_AN
Circuit C	ECO_TP_C	MAIN MENU\Status\CIRCC_AN	11	RO	Status Display Tables\CIRCC_AN
<b>Economizer Pressure</b>					
Circuit A	ECON_P_A	MAIN MENU\Status\CIRCA_AN	5	RO	Status Display Tables\CIRCA_AN
Circuit B	ECON_P_B	MAIN MENU\Status\CIRCB_AN	5	RO	Status Display Tables\CIRCB_AN
Circuit C	ECON_P_C	MAIN MENU\Status\CIRCC_AN	5	RO	Status Display Tables\CIRCC_AN
<b>EHS Ctrl Override</b>	over_ehs	MAIN MENU\Maint\LOADFACT	22	RO	Maintenance Display Tables\LOADFACT
<b>Elec Stage OAT Threshold</b>	ehs_th	MAIN MENU\Config\USER	34	RW	Configuration Tables\USER
<b>Electric Heat Active</b>	Mode_15	MAIN MENU\Status\MODES	16	RO	Status Display Tables\MODES
<b>Electrical Box Interlock</b>	ELEC_BOX	MAIN MENU\Status\STATEGEN	16	RO	Status Display Tables\STATEGEN
<b>Electrical Heat Stage</b>	EHS_STEP	MAIN MENU\Status\STATEGEN	19	RO	Status Display Tables\STATEGEN
<b>Electrical Heat Stages</b>	ehs_sel	MAIN MENU\Service\FACTORY	16	RW	Service Configuration Tables\FACTORY
<b>Electrical Pulldown Time</b>	ehs_pull	MAIN MENU\Config\USER	36	RW	Configuration Tables\USER
<b>Electrical Pulldown?</b>	ehspulld	MAIN MENU\Maint\LOADFACT	24	RO	Maintenance Display Tables\LOADFACT
<b>Element</b>	Element	MAIN MENU\Config\Ctr-ID	8	RO	Configuration Tables\CtrID\PD5_XAXQ
<b>Emergency Stop</b>	EMSTOP	MAIN MENU\Status\GENUNIT	32	RO	Status Display Tables\GENUNIT
<b>EMM NRCP2 Board</b>	EMM_NRCP	MAIN MENU\Maint\BOARD_PN	9	RO	Maintenance Display Tables\BOARD_PN
<b>Energy Management Module</b>	emm_nrpc	MAIN MENU\Service\FACTORY	17	RW	Service Configuration Tables\FACTORY
<b>Entering Fluid Control</b>	ewt_opt	MAIN MENU\Service\SERVICE1	5	RW	Service Configuration Tables\SERVICE1
<b>Estimated FreeCool Power</b>	fc_pwr	MAIN MENU\Status\FREECOOL	5	RO	Status Display Tables\FREECOOL
<b>Exchanger Frost Factor</b>					
Circuit A	frost_a	MAIN MENU\Maint\DEFROSTM	2	RO	Maintenance Display Tables\DEFROSTM
Circuit B	frost_b	MAIN MENU\Maint\DEFROSTM	19	RO	Maintenance Display Tables\DEFROSTM
<b>External Temperature</b>	OAT	MAIN MENU\Status\GENUNIT	30	RO	Status Display Tables\GENUNIT
<b>EXV A Maximum Steps Numb</b>	exva_max	MAIN MENU\Service\FACTORY2	18	RW	Service Configuration Tables\FACTORY2
<b>EXV A Superheat Setpoint</b>	sh_sp_a	MAIN MENU\Service\SERVICE1	9	RW	Service Configuration Tables\SERVICE1
<b>EXV B Maximum Steps Numb</b>	exvb_max	MAIN MENU\Service\FACTORY2	19	RW	Service Configuration Tables\FACTORY2
<b>EXV B Superheat Setpoint</b>	sh_sp_b	MAIN MENU\Service\SERVICE1	10	RW	Service Configuration Tables\SERVICE1
<b>EXV Board Circuit A</b>	EXV_BRD1	MAIN MENU\Maint\BOARD_PN	1	RO	Maintenance Display Tables\BOARD_PN
<b>EXV Board Circuit B</b>	EXV_BRD2	MAIN MENU\Maint\BOARD_PN	2	RO	Maintenance Display Tables\BOARD_PN
<b>EXV Board Circuit C</b>	EXV_BRD3	MAIN MENU\Maint\BOARD_PN	3	RO	Maintenance Display Tables\BOARD_PN
<b>EXV C Maximum Steps Numb</b>	exvc_max	MAIN MENU\Service\FACTORY2	20	RW	Service Configuration Tables\FACTORY2
<b>EXV C Superheat Setpoint</b>	sh_sp_c	MAIN MENU\Service\SERVICE1	11	RW	Service Configuration Tables\SERVICE1
<b>EXV MOP Setpoint</b>	mop_sp	MAIN MENU\Service\SERVICE1	15	RW	Service Configuration Tables\SERVICE1
<b>EXV Override Circuit A</b>	oc_eco_a	MAIN MENU\Maint\EXV_CTRL	28	RO	Maintenance Display Tables\EXV_CTRL
<b>EXV Override Circuit A</b>	ov_exv_a	MAIN MENU\Maint\EXV_CTRL	8	RO	Maintenance Display Tables\EXV_CTRL
<b>EXV Override Circuit B</b>	oc_eco_b	MAIN MENU\Maint\EXV_CTRL	32	RO	Maintenance Display Tables\EXV_CTRL
<b>EXV Override Circuit B</b>	ov_exv_b	MAIN MENU\Maint\EXV_CTRL	15	RO	Maintenance Display Tables\EXV_CTRL
<b>EXV Override Circuit C</b>	oc_eco_c	MAIN MENU\Maint\EXV_CTRL	36	RO	Maintenance Display Tables\EXV_CTRL
<b>EXV Override Circuit C</b>	ov_exv_c	MAIN MENU\Maint\EXV_CTRL	22	RO	Maintenance Display Tables\EXV_CTRL
<b>EXV Position Circuit A</b>	EXV_A	MAIN MENU\Maint\EXV_CTRL	2	RO	Maintenance Display Tables\EXV_CTRL
<b>EXV Position Circuit B</b>	EXV_B	MAIN MENU\Maint\EXV_CTRL	9	RO	Maintenance Display Tables\EXV_CTRL
<b>EXV Position Circuit C</b>	EXV_C	MAIN MENU\Maint\EXV_CTRL	16	RO	Maintenance Display Tables\EXV_CTRL
<b>EXV Position</b>					
Circuit A	Q_EXVA	MAIN MENU\Status\QCK_TST1	3	RW	Status Display Tables\QCK_TST1
Circuit B	Q_EXVB	MAIN MENU\Status\QCK_TST1	4	RW	Status Display Tables\QCK_TST1
Circuit C	Q_EXVC	MAIN MENU\Status\QCK_TST1	5	RW	Status Display Tables\QCK_TST1
<b>EXV Position</b>					
Circuit A	EXV_A	MAIN MENU\Status\CIRCA_AN	15	RO	Status Display Tables\CIRCA_AN
Circuit B	EXV_B	MAIN MENU\Status\CIRCB_AN	15	RO	Status Display Tables\CIRCB_AN
Circuit C	EXV_C	MAIN MENU\Status\CIRCC_AN	15	RO	Status Display Tables\CIRCC_AN

**LEGEND**

**RO** — Read Only  
**RW** — Read/Write



**APPENDIX A — TOUCH PILOT™ DISPLAY TABLES (cont)**

TOUCH PILOT DESCRIPTION	TOUCH PILOT POINT NAME	TOUCH PILOT PATH	LINE	READ/ WRITE	CCN TABLE NAME
<b>EXV Position</b>					
<b>Circuit A</b>	EXV_A	MAIN MENU\Status\FREECOOL	20	RO	Status Display Tables\FREECOOL
<b>Circuit B</b>	EXV_B	MAIN MENU\Status\FREECOOL	30	RO	Status Display Tables\FREECOOL
<b>Circuit C</b>	EXV_C	MAIN MENU\Status\FREECOOL	40	RO	Status Display Tables\FREECOOL
<b>Factory Password</b>	fac_pass	MAIN MENU\Service\FACTORY	19	RW	Service Configuration Tables\FACTORY
<b>Fan #1 Hours</b>					
<b>Circuit A</b>	hr_fana1	MAIN MENU\Service\UPDHRFAN	8	RW	Service Configuration Tables\UPDHRFAN
<b>Circuit B</b>	hr_fanb1	MAIN MENU\Service\UPDHRFAN	18	RW	Service Configuration Tables\UPDHRFAN
<b>Circuit C</b>	hr_fanc1	MAIN MENU\Service\UPDHRFAN	28	RW	Service Configuration Tables\UPDHRFAN
<b>Fan #1 Hours</b>					
<b>Circuit A</b>	hr_fana1	MAIN MENU\Status\FANHOURS	5	RO	Status Display Tables\FANHOURS
<b>Circuit B</b>	hr_fanb1	MAIN MENU\Status\FANHOURS	15	RO	Status Display Tables\FANHOURS
<b>Circuit C</b>	hr_fanc1	MAIN MENU\Status\FANHOURS	25	RO	Status Display Tables\FANHOURS
<b>Fan #2 Hours</b>					
<b>Circuit A</b>	hr_fana2	MAIN MENU\Service\UPDHRFAN	9	RW	Service Configuration Tables\UPDHRFAN
<b>Circuit B</b>	hr_fanb2	MAIN MENU\Service\UPDHRFAN	19	RW	Service Configuration Tables\UPDHRFAN
<b>Circuit C</b>	hr_fanc2	MAIN MENU\Service\UPDHRFAN	29	RW	Service Configuration Tables\UPDHRFAN
<b>Fan #2 Hours</b>					
<b>Circuit A</b>	hr_fana2	MAIN MENU\Status\FANHOURS	6	RO	Status Display Tables\FANHOURS
<b>Circuit B</b>	hr_fanb2	MAIN MENU\Status\FANHOURS	16	RO	Status Display Tables\FANHOURS
<b>Circuit C</b>	hr_fanc2	MAIN MENU\Status\FANHOURS	26	RO	Status Display Tables\FANHOURS
<b>Fan #3 Hours</b>					
<b>Circuit A</b>	hr_fana3	MAIN MENU\Service\UPDHRFAN	10	RW	Service Configuration Tables\UPDHRFAN
<b>Circuit B</b>	hr_fanb3	MAIN MENU\Service\UPDHRFAN	20	RW	Service Configuration Tables\UPDHRFAN
<b>Circuit C</b>	hr_fanc3	MAIN MENU\Service\UPDHRFAN	30	RW	Service Configuration Tables\UPDHRFAN
<b>Fan #3 Hours</b>					
<b>Circuit A</b>	hr_fana3	MAIN MENU\Status\FANHOURS	7	RO	Status Display Tables\FANHOURS
<b>Circuit B</b>	hr_fanb3	MAIN MENU\Status\FANHOURS	17	RO	Status Display Tables\FANHOURS
<b>Circuit C</b>	hr_fanc3	MAIN MENU\Status\FANHOURS	27	RO	Status Display Tables\FANHOURS
<b>Fan #4 Hours</b>					
<b>Circuit A</b>	hr_fana4	MAIN MENU\Service\UPDHRFAN	11	RW	Service Configuration Tables\UPDHRFAN
<b>Circuit B</b>	hr_fanb4	MAIN MENU\Service\UPDHRFAN	21	RW	Service Configuration Tables\UPDHRFAN
<b>Circuit C</b>	hr_fanc4	MAIN MENU\Service\UPDHRFAN	31	RW	Service Configuration Tables\UPDHRFAN
<b>Fan #4 Hours</b>					
<b>Circuit A</b>	hr_fana4	MAIN MENU\Status\FANHOURS	8	RO	Status Display Tables\FANHOURS
<b>Circuit B</b>	hr_fanb4	MAIN MENU\Status\FANHOURS	18	RO	Status Display Tables\FANHOURS
<b>Circuit C</b>	hr_fanc4	MAIN MENU\Status\FANHOURS	28	RO	Status Display Tables\FANHOURS
<b>Fan #5 Hours</b>					
<b>Circuit A</b>	hr_fana5	MAIN MENU\Service\UPDHRFAN	12	RW	Service Configuration Tables\UPDHRFAN
<b>Circuit B</b>	hr_fanb5	MAIN MENU\Service\UPDHRFAN	22	RW	Service Configuration Tables\UPDHRFAN
<b>Circuit C</b>	hr_fanc5	MAIN MENU\Service\UPDHRFAN	32	RW	Service Configuration Tables\UPDHRFAN
<b>Fan #5 Hours</b>					
<b>Circuit A</b>	hr_fana5	MAIN MENU\Status\FANHOURS	9	RO	Status Display Tables\FANHOURS
<b>Circuit B</b>	hr_fanb5	MAIN MENU\Status\FANHOURS	19	RO	Status Display Tables\FANHOURS
<b>Circuit C</b>	hr_fanc5	MAIN MENU\Status\FANHOURS	29	RO	Status Display Tables\FANHOURS
<b>Fan #6 Hours</b>					
<b>Circuit A</b>	hr_fana6	MAIN MENU\Service\UPDHRFAN	13	RW	Service Configuration Tables\UPDHRFAN
<b>Circuit B</b>	hr_fanb6	MAIN MENU\Service\UPDHRFAN	23	RW	Service Configuration Tables\UPDHRFAN
<b>Circuit C</b>	hr_fanc6	MAIN MENU\Service\UPDHRFAN	33	RW	Service Configuration Tables\UPDHRFAN
<b>Fan #6 Hours</b>					
<b>Circuit A</b>	hr_fana6	MAIN MENU\Status\FANHOURS	10	RO	Status Display Tables\FANHOURS
<b>Circuit B</b>	hr_fanb6	MAIN MENU\Status\FANHOURS	20	RO	Status Display Tables\FANHOURS
<b>Circuit C</b>	hr_fanc6	MAIN MENU\Status\FANHOURS	30	RO	Status Display Tables\FANHOURS

**LEGEND**

**RO** — Read Only  
**RW** — Read/Write

**APPENDIX A — TOUCH PILOT™ DISPLAY TABLES (cont)**

TOUCH PILOT DESCRIPTION	TOUCH PILOT POINT NAME	TOUCH PILOT PATH	LINE	READ/ WRITE	CCN TABLE NAME
<b>Fan #7 Hours</b>					
<b>Circuit A</b>	hr_fana7	MAIN MENU\Service\UPDHRFAN	14	RW	Service Configuration Tables\UPDHRFAN
<b>Circuit B</b>	hr_fanb7	MAIN MENU\Service\UPDHRFAN	24	RW	Service Configuration Tables\UPDHRFAN
<b>Circuit C</b>	hr_fanc7	MAIN MENU\Service\UPDHRFAN	34	RW	Service Configuration Tables\UPDHRFAN
<b>Fan #7 Hours</b>					
<b>Circuit A</b>	hr_fana7	MAIN MENU>Status\FANHOURS	11	RO	Status Display Tables\FANHOURS
<b>Circuit B</b>	hr_fanb7	MAIN MENU>Status\FANHOURS	21	RO	Status Display Tables\FANHOURS
<b>Circuit C</b>	hr_fanc7	MAIN MENU>Status\FANHOURS	31	RO	Status Display Tables\FANHOURS
<b>Fan #8 Hours</b>					
<b>Circuit A</b>	hr_fana8	MAIN MENU\Service\UPDHRFAN	15	RW	Service Configuration Tables\UPDHRFAN
<b>Circuit B</b>	hr_fanb8	MAIN MENU\Service\UPDHRFAN	25	RW	Service Configuration Tables\UPDHRFAN
<b>Circuit C</b>	hr_fanc8	MAIN MENU\Service\UPDHRFAN	35	RW	Service Configuration Tables\UPDHRFAN
<b>Fan #8 Hours</b>					
<b>Circuit A</b>	hr_fana8	MAIN MENU>Status\FANHOURS	12	RO	Status Display Tables\FANHOURS
<b>Circuit B</b>	hr_fanb8	MAIN MENU>Status\FANHOURS	22	RO	Status Display Tables\FANHOURS
<b>Circuit C</b>	hr_fanc8	MAIN MENU>Status\FANHOURS	32	RO	Status Display Tables\FANHOURS
<b>Fan #9 Hours</b>					
<b>Circuit A</b>	hr_fana9	MAIN MENU\Service\UPDHRFAN	16	RW	Service Configuration Tables\UPDHRFAN
<b>Circuit B</b>	hr_fanb9	MAIN MENU\Service\UPDHRFAN	26	RW	Service Configuration Tables\UPDHRFAN
<b>Circuit C</b>	hr_fanc9	MAIN MENU\Service\UPDHRFAN	36	RW	Service Configuration Tables\UPDHRFAN
<b>Fan #9 Hours</b>					
<b>Circuit A</b>	hr_fana9	MAIN MENU>Status\FANHOURS	13	RO	Status Display Tables\FANHOURS
<b>Circuit B</b>	hr_fanb9	MAIN MENU>Status\FANHOURS	23	RO	Status Display Tables\FANHOURS
<b>Circuit C</b>	hr_fanc9	MAIN MENU>Status\FANHOURS	33	RO	Status Display Tables\FANHOURS
<b>Fan #10 Hours</b>					
<b>Circuit A</b>	hrfana10	MAIN MENU\Service\UPDHRFAN	17	RW	Service Configuration Tables\UPDHRFAN
<b>Circuit B</b>	hrfanb10	MAIN MENU\Service\UPDHRFAN	27	RW	Service Configuration Tables\UPDHRFAN
<b>Circuit C</b>	hrfanc10	MAIN MENU\Service\UPDHRFAN	37	RW	Service Configuration Tables\UPDHRFAN
<b>Fan #10 Hours</b>					
<b>Circuit A</b>	hrfana10	MAIN MENU>Status\FANHOURS	14	RO	Status Display Tables\FANHOURS
<b>Circuit B</b>	hrfanb10	MAIN MENU>Status\FANHOURS	24	RO	Status Display Tables\FANHOURS
<b>Circuit C</b>	hrfanc10	MAIN MENU>Status\FANHOURS	34	RO	Status Display Tables\FANHOURS
<b>Fan Cycle Counter</b>					
<b>Circuit A</b>	fancyc_a	MAIN MENU\Maint\FANCTRL	3	RO	Maintenance Display Tables\FANCTRL
<b>Circuit B</b>	fancyc_b	MAIN MENU\Maint\FANCTRL	7	RO	Maintenance Display Tables\FANCTRL
<b>Circuit C</b>	fancyc_c	MAIN MENU\Maint\FANCTRL	11	RO	Maintenance Display Tables\FANCTRL
<b>Fan Output DO #1</b>					
<b>Circuit A</b>	fan_a1	MAIN MENU>Status\CIRCA_D	11	RO	Status Display Tables\CIRCA_D
<b>Circuit B</b>	fan_b1	MAIN MENU>Status\CIRCB_D	11	RO	Status Display Tables\CIRCB_D
<b>Circuit C</b>	fan_c1	MAIN MENU>Status\CIRCC_D	11	RO	Status Display Tables\CIRCC_D
<b>Fan Output DO #2</b>					
<b>Circuit A</b>	fan_a2	MAIN MENU>Status\CIRCA_D	12	RO	Status Display Tables\CIRCA_D
<b>Circuit B</b>	fan_b2	MAIN MENU>Status\CIRCB_D	12	RO	Status Display Tables\CIRCB_D
<b>Circuit C</b>	fan_c2	MAIN MENU>Status\CIRCC_D	12	RO	Status Display Tables\CIRCC_D
<b>Fan Output DO #3</b>					
<b>Circuit A</b>	fan_a3	MAIN MENU>Status\CIRCA_D	13	RO	Status Display Tables\CIRCA_D
<b>Circuit B</b>	fan_b3	MAIN MENU>Status\CIRCB_D	13	RO	Status Display Tables\CIRCB_D
<b>Circuit C</b>	fan_c3	MAIN MENU>Status\CIRCC_D	13	RO	Status Display Tables\CIRCC_D
<b>Fan Output DO #4</b>					
<b>Circuit A</b>	fan_a4	MAIN MENU>Status\CIRCA_D	14	RO	Status Display Tables\CIRCA_D
<b>Circuit B</b>	fan_b4	MAIN MENU>Status\CIRCB_D	14	RO	Status Display Tables\CIRCB_D
<b>Circuit C</b>	fan_c4	MAIN MENU>Status\CIRCC_D	14	RO	Status Display Tables\CIRCC_D

LEGEND

RO — Read Only  
RW — Read/Write

**APPENDIX A — TOUCH PILOT™ DISPLAY TABLES (cont)**

TOUCH PILOT DESCRIPTION	TOUCH PILOT POINT NAME	TOUCH PILOT PATH	LINE	READ/ WRITE	CCN TABLE NAME
<b>Fan Output DO #5</b>					
Circuit A	fan_a5	MAIN MENU\Status\CIRCA_D	15	RO	Status Display Tables\CIRCA_D
Circuit B	fan_b5	MAIN MENU\Status\CIRCB_D	15	RO	Status Display Tables\CIRCB_D
Circuit C	fan_c5	MAIN MENU\Status\CIRCC_D	15	RO	Status Display Tables\CIRCC_D
<b>Fan Output DO #6</b>					
Circuit A	fan_a6	MAIN MENU\Status\CIRCA_D	16	RO	Status Display Tables\CIRCA_D
Circuit B	fan_b6	MAIN MENU\Status\CIRCB_D	16	RO	Status Display Tables\CIRCB_D
Circuit C	fan_c6	MAIN MENU\Status\CIRCC_D	16	RO	Status Display Tables\CIRCC_D
<b>Fan Output DO #7</b>					
Circuit A	fan_a7	MAIN MENU\Status\CIRCA_D	17	RO	Status Display Tables\CIRCA_D
Circuit B	fan_b7	MAIN MENU\Status\CIRCB_D	17	RO	Status Display Tables\CIRCB_D
Circuit C	fan_c7	MAIN MENU\Status\CIRCC_D	17	RO	Status Display Tables\CIRCC_D
<b>Fan Output DO #8</b>					
Circuit A	fan_a7	MAIN MENU\Status\CIRCA_D	17	RO	Status Display Tables\CIRCA_D
Circuit B	fan_b7	MAIN MENU\Status\CIRCB_D	17	RO	Status Display Tables\CIRCB_D
Circuit C	fan_c7	MAIN MENU\Status\CIRCC_D	17	RO	Status Display Tables\CIRCC_D
<b>Fan Sequence Started?</b>					
Circuit A	def_fa_a	MAIN MENU\Maint\DEFROSTM	7	RO	Maintenance Display Tables\DEFROSTM
Circuit B	def_fa_b	MAIN MENU\Maint\DEFROSTM	24	RO	Maintenance Display Tables\DEFROSTM
<b>Fan Stages</b>					
Circuit A	Q_FAN_A	MAIN MENU\Status\QCK_TST1	9	RW	Status Display Tables\QCK_TST1
Circuit B	Q_FAN_B	MAIN MENU\Status\QCK_TST1	10	RW	Status Display Tables\QCK_TST1
Circuit C	Q_FAN_C	MAIN MENU\Status\QCK_TST1	11	RW	Status Display Tables\QCK_TST1
<b>Fan Staging Number</b>					
Circuit A	FAN_ST_A	MAIN MENU\Status\CIRCA_D	19	RO	Status Display Tables\CIRCA_D
Circuit B	FAN_ST_B	MAIN MENU\Status\CIRCB_D	19	RO	Status Display Tables\CIRCB_D
Circuit C	FAN_ST_C	MAIN MENU\Status\CIRCC_D	19	RO	Status Display Tables\CIRCC_D
<b>Fan Staging Number</b>					
Circuit A	FAN_ST_A	MAIN MENU\Status\FREECOOL	13	RO	Status Display Tables\FREECOOL
Circuit B	FAN_ST_B	MAIN MENU\Status\FREECOOL	23	RO	Status Display Tables\FREECOOL
Circuit C	FAN_ST_C	MAIN MENU\Status\FREECOOL	33	RO	Status Display Tables\FREECOOL
<b>Flow Checked if C Pump Off</b>	pump_loc	MAIN MENU\Config\USER	17	RW	Configuration Tables\USER
<b>Free Cool A Ball Valve</b>	Q_FCBVL_A	MAIN MENU\Status\QCK_TST2	18	RO	Status Display Tables\QCK_TST2
<b>Free Cool A EXV Position</b>	Q_FCEXVA	MAIN MENU\Status\QCK_TST2	16	RO	Status Display Tables\QCK_TST2
<b>Free Cool B Ball Valve</b>	Q_FCBVL_B	MAIN MENU\Status\QCK_TST2	19	RO	Status Display Tables\QCK_TST2
<b>Free Cool B EXV Position</b>	Q_FCEXVB	MAIN MENU\Status\QCK_TST2	17	RO	Status Display Tables\QCK_TST2
<b>Free Cool Conditions OK?</b>	fc_ready	MAIN MENU\Status\FREECOOL	8	RO	Status Display Tables\FREECOOL
<b>Free Cool Pump A Hours</b>	hr_fcm_a	MAIN MENU\Status\FANHOURS	1	RO	Status Display Tables\FANHOURS
<b>Free Cool Pump B Hours</b>	hr_fcm_b	MAIN MENU\Status\FANHOURS	2	RO	Status Display Tables\FANHOURS
<b>Free Cool Request?</b>	fc_reqst	MAIN MENU\Status\FREECOOL	9	RO	Status Display Tables\FREECOOL
<b>Free Cooling A Pump Hours</b>	hr_fcp_a	MAIN MENU\Service\UPDHRFAN	4	RW	Service Configuration Tables\UPDHRFAN
<b>Free Cooling Active</b>	Mode_13	MAIN MENU\Status\MODES	14	RO	Status Display Tables\MODES
<b>Free Cooling Active</b>					
Circuit A	FC_ON_A	MAIN MENU\Status\FREECOOL	12	RO	Status Display Tables\FREECOOL
Circuit B	FC_ON_B	MAIN MENU\Status\FREECOOL	22	RO	Status Display Tables\FREECOOL
Circuit C	FC_ON_C	MAIN MENU\Status\FREECOOL	32	RO	Status Display Tables\FREECOOL
<b>Free Cooling B Pump Hours</b>	hr_fcp_b	MAIN MENU\Service\UPDHRFAN	5	RW	Service Configuration Tables\UPDHRFAN
<b>Free Cooling Disable</b>	FC_DSBLE	MAIN MENU\Status\GENUNIT	12	RW	Status Display Tables\GENUNIT
<b>Free Cooling Disable Sw</b>	FC_SW	MAIN MENU\Status\STATEGEN	6	RO	Status Display Tables\STATEGEN
<b>Free Cooling Disable?</b>	FC_DSBLE	MAIN MENU\Status\FREECOOL	2	RO	Status Display Tables\FREECOOL
<b>Free Cooling Heater</b>	Q_FC_HTR	MAIN MENU\Status\QCK_TST2	15	RO	Status Display Tables\QCK_TST2
<b>Free Cooling OAT Limit</b>	free_oat	MAIN MENU\Config\USER	33	RW	Configuration Tables\USER
<b>Free Cooling Select</b>	freecool	MAIN MENU\Service\FACTORY	11	RW	Service Configuration Tables\FACTORY

**LEGEND**

**RO** — Read Only  
**RW** — Read/Write

**APPENDIX A — TOUCH PILOT™ DISPLAY TABLES (cont)**

TOUCH PILOT DESCRIPTION	TOUCH PILOT POINT NAME	TOUCH PILOT PATH	LINE	READ/ WRITE	CCN TABLE NAME
Frost Integrator Gain					
Circuit A	fr_int_a	MAIN MENU\Maint\DEFROSTM	14	RO	Maintenance Display Tables\DEFROSTM
Circuit B	fr_int_b	MAIN MENU\Maint\DEFROSTM	31	RO	Maintenance Display Tables\DEFROSTM
Head Press Speed					
Circuit A	Q_VFANA	MAIN MENU>Status\QCK_TST1	12	RW	Status Display Tables\QCK_TST1
Circuit B	Q_VFANB	MAIN MENU>Status\QCK_TST1	13	RW	Status Display Tables\QCK_TST1
Circuit C	Q_VFANC	MAIN MENU>Status\QCK_TST1	14	RW	Status Display Tables\QCK_TST1
HEAT RECLAIM CIRCUIT A	—	MAIN MENU>Status\RECLAIM	9	RO	Status Display Tables\RECLAIM
HEAT RECLAIM CIRCUIT B	—	MAIN MENU>Status\RECLAIM	19	RO	Status Display Tables\RECLAIM
Heat Reclaim Select	RECL_SEL	MAIN MENU>Status\RECLAIM	1	RO	Status Display Tables\RECLAIM
Heat Reclaim Select	RECL_SET	MAIN MENU>Status\GENUNIT	11	RW	Status Display Tables\GENUNIT
Heat/Cool Select	HC_SEL	MAIN MENU>Status\GENUNIT	9	RW	Status Display Tables\GENUNIT
Heat/Cool Status	HEATCOOL	MAIN MENU>Status\GENUNIT	8	RO	Status Display Tables\GENUNIT
Heating Changeover Setpt	haut_o_sp	MAIN MENU\Setpoint\SETPOINT	30	RW	Setpoint Configuration Tables\SETPOINT
Heating Low EWT Lockout	Mode_16	MAIN MENU>Status\MODES	17	RO	Status Display Tables\MODES
Heating OAT Threshold	heat_th	MAIN MENU\Config\USER	32	RW	Configuration Tables\USER
Heating Ramp Loading	hramp_sp	MAIN MENU\Setpoint\SETPOINT	26	RW	Setpoint Configuration Tables\SETPOINT
Heating Reset Deg. Value	hr_deg	MAIN MENU\Setpoint\SETPOINT	25	RW	Setpoint Configuration Tables\SETPOINT
Heating Reset Select	hr_sel	MAIN MENU\Config\USER	20	RW	Configuration Tables\USER
Heating Setpoint 1	hsp1	MAIN MENU\Setpoint\SETPOINT	17	RW	Setpoint Configuration Tables\SETPOINT
Heating Setpoint 2	hsp2	MAIN MENU\Setpoint\SETPOINT	18	RW	Setpoint Configuration Tables\SETPOINT
High Condensing Select	highcond	MAIN MENU\Service\FACTORY	24	RW	Service Configuration Tables\FACTORY
High DGT Circuit A	Mode_24	MAIN MENU>Status\MODES	25	RO	Status Display Tables\MODES
High DGT Circuit B	Mode_25	MAIN MENU>Status\MODES	26	RO	Status Display Tables\MODES
High DGT Circuit C	Mode_26	MAIN MENU>Status\MODES	27	RO	Status Display Tables\MODES
High Pres Override Cir A	Mode_27	MAIN MENU>Status\MODES	28	RO	Status Display Tables\MODES
High Pres Override Cir B	Mode_28	MAIN MENU>Status\MODES	29	RO	Status Display Tables\MODES
High Pres Override Cir C	Mode_29	MAIN MENU>Status\MODES	30	RO	Status Display Tables\MODES
High Pressure Threshold	hp_th	MAIN MENU\Service\SERVICE1	16	RW	Service Configuration Tables\SERVICE1
High Tiers Display Selec	highdisp	MAIN MENU\Service\FACTORY	18	RW	Service Configuration Tables\FACTORY
Holiday Duration (days)	HOL-LEN	MAIN MENU\Config\HOLIDAY\HOLDY_01	3	RW	Configuration Tables\HOLIDAY\HOLDY_01
Holiday Start Day	HOL-DAY	MAIN MENU\Config\HOLIDAY\HOLDY_01	2	RW	Configuration Tables\HOLIDAY\HOLDY_01
Holiday Start Month	HOL-MON	MAIN MENU\Config\HOLIDAY\HOLDY_01	1	RW	Configuration Tables\HOLIDAY\HOLDY_01
Hot Gas Bypass Select	hgbp_sel	MAIN MENU\Service\FACTORY	14	RW	Service Configuration Tables\FACTORY
Head Press Actuator Pos					
Circuit A	hd_pos_a	MAIN MENU>Status\CIRCA_AN	16	RO	Status Display Tables\CIRCA_AN
Circuit B	hd_pos_b	MAIN MENU>Status\CIRCB_AN	16	RO	Status Display Tables\CIRCB_AN
Circuit C	hd_pos_c	MAIN MENU>Status\CIRCC_AN	16	RO	Status Display Tables\CIRCC_AN
Heater Ball Valve					
Circuit A	Q_BVL_A	MAIN MENU>Status\QCK_TST1	19	RW	Status Display Tables\QCK_TST1
Circuit B	Q_BVL_B	MAIN MENU>Status\QCK_TST1	26	RW	Status Display Tables\QCK_TST1
Circuit C	Q_BVL_C	MAIN MENU>Status\QCK_TST1	33	RW	Status Display Tables\QCK_TST1
Hot Gas Bypass Output					
Circuit A	HGBP_A	MAIN MENU>Status\CIRCA_D	9	RO	Status Display Tables\CIRCA_D
Circuit B	HGBP_B	MAIN MENU>Status\CIRCB_D	9	RO	Status Display Tables\CIRCB_D
Circuit C	HGBP_C	MAIN MENU>Status\CIRCC_D	9	RO	Status Display Tables\CIRCC_D
Hot Gas Bypass					
Circuit A	Q_HGBP_A	MAIN MENU>Status\QCK_TST1	20	RW	Status Display Tables\QCK_TST1
Circuit B	Q_HGBP_B	MAIN MENU>Status\QCK_TST1	27	RW	Status Display Tables\QCK_TST1
Circuit C	Q_HGBP_C	MAIN MENU>Status\QCK_TST1	34	RW	Status Display Tables\QCK_TST1
HPump 1 Ctl Delay (days)	hpump1_c	MAIN MENU\Service\MAINTCFG	7	RW	Service Configuration Tables\MAINTCFG
HPump 2 Ctl Delay (days)	hpump2_c	MAIN MENU\Service\MAINTCFG	8	RW	Service Configuration Tables\MAINTCFG
HR Condenser Heater	Q_CD_HT	MAIN MENU>Status\QCK_TST2	12	RW	Status Display Tables\QCK_TST2
Ice Done Storage Switch	ICE_SW	MAIN MENU>Status\STATEGEN	11	RO	Status Display Tables\STATEGEN

LEGEND

RO — Read Only  
RW — Read/Write

**APPENDIX A — TOUCH PILOT™ DISPLAY TABLES (cont)**

TOUCH PILOT DESCRIPTION	TOUCH PILOT POINT NAME	TOUCH PILOT PATH	LINE	READ/ WRITE	CCN TABLE NAME
Ice Mode Enable	ice_cnfg	MAIN MENU\Config\USER	42	RW	Configuration Tables\USER
Ice Mode in Effect	Mode_18	MAIN MENU>Status\MODES	19	RO	Status Display Tables\MODES
Int PID Gain Varifan	hd_ig	MAIN MENU\Service\SERVICE1	7	RW	Service Configuration Tables\SERVICE1
Lag Capacity Limit Value	LAG_LIM	MAIN MENU>Status\GENUNIT	22	RO	Status Display Tables\GENUNIT
Lag Minimum Running Time	lag_mini	MAIN MENU\Config\MST_SLV	20	RW	Configuration Tables\MST_SLV
Lag Start Delay	l_strt_d	MAIN MENU\Maint\M_MSTSLV	8	RO	Maintenance Display Tables\MSTSLAVE
Lag Start Timer	lstr_tim	MAIN MENU\Config\MST_SLV	17	RW	Configuration Tables\MST_SLV
Lag Unit Pump Control	lag_pump	MAIN MENU\Config\MST_SLV	21	RW	Configuration Tables\MST_SLV
Language Selection	LANGUAGE	MAIN MENU\Config\DISPCONF	2	RW	Configuration Tables\DISPCONF
Lead Lag Select	lead_sel	MAIN MENU\Config\MST_SLV	12	RW	Configuration Tables\MST_SLV
Lead Pulldown Time	lead_pul	MAIN MENU\Config\MST_SLV	18	RW	Configuration Tables\MST_SLV
Lead Pulldown?	ll_pull	MAIN MENU\Maint\M_MSTSLV	11	RO	Maintenance Display Tables\MSTSLAVE
Lead Unit is the:	lead_sel	MAIN MENU\Maint\M_MSTSLV	5	RO	Maintenance Display Tables\MSTSLAVE
Lead/Lad Changeover?	ll_chang	MAIN MENU\Maint\M_MSTSLV	10	RO	Maintenance Display Tables\MSTSLAVE
Lead/Lag Balance Delta	ll_bal_d	MAIN MENU\Config\MST_SLV	16	RW	Configuration Tables\MST_SLV
Lead/Lag Hours Delta	ll_hr_d	MAIN MENU\Maint\M_MSTSLV	9	RO	Maintenance Display Tables\MSTSLAVE
Limit 4-20mA Signal	LIM_ANAL	MAIN MENU>Status\STATEGEN	42	RO	Status Display Tables\STATEGEN
Limit Switch 1 Status	LIM_SW1	MAIN MENU>Status\STATEGEN	8	RO	Status Display Tables\STATEGEN
Limit Switch 2 Status	LIM_SW2	MAIN MENU>Status\STATEGEN	9	RO	Status Display Tables\STATEGEN
Load/Unload Factor	smz	MAIN MENU\Maint\LOADFACT	19	RO	Maintenance Display Tables\LOADFACT
Location	Location	MAIN MENU\Config\Ctr-ID	2	RO	Configuration Tables!\CtrlID\PD5_XAXQ
Low Suction Circuit A	Mode_21	MAIN MENU>Status\MODES	22	RO	Status Display Tables\MODES
Low Suction Circuit B	Mode_22	MAIN MENU>Status\MODES	23	RO	Status Display Tables\MODES
Low Suction Circuit C	Mode_23	MAIN MENU>Status\MODES	24	RO	Status Display Tables\MODES
Low Superheat Circuit A	Mode_30	MAIN MENU>Status\MODES	31	RO	Status Display Tables\MODES
Low Superheat Circuit B	Mode_31	MAIN MENU>Status\MODES	32	RO	Status Display Tables\MODES
Low Superheat Circuit C	Mode_32	MAIN MENU>Status\MODES	33	RO	Status Display Tables\MODES
LWT-OAT Delta	fc_delta	MAIN MENU>Status\FREECOOL	3	RO	Status Display Tables\FREECOOL
mA For 0% Demand Limit	lim_ze	MAIN MENU\Config\USER	29	RW	Configuration Tables\USER
mA For 100% Demand Limit	lim_mx	MAIN MENU\Config\USER	28	RW	Configuration Tables\USER
Machine Operating Hours	hr_mach	MAIN MENU\Service\UPDTHOUR	5	RW	Service Configuration Tables\UPDTHOUR
Machine Operating Hours	HR_MACH	MAIN MENU>Status\STRTHOUR	1	RO	Status Display Tables\STRTHOUR
Machine Starts	st_mach	MAIN MENU\Service\UPDTHOUR	6	RW	Service Configuration Tables\UPDTHOUR
Machine Starts Number	st_mach	MAIN MENU>Status\STRTHOUR	2	RO	Status Display Tables\STRTHOUR
Master Control Type	ms_ctrl	MAIN MENU\Config\MST_SLV	7	RW	Configuration Tables\MST_SLV
Master Control Type	ms_ctrl	MAIN MENU\Maint\M_MSTSLV	3	RO	Maintenance Display Tables\MSTSLAVE
Master Slave Active	Mode_11	MAIN MENU>Status\MODES	12	RO	Status Display Tables\MODES
Master/Slave Ctrl Active	ms_activ	MAIN MENU\Maint\M_MSTSLV	4	RO	Maintenance Display Tables\MSTSLAVE
Master/Slave Error	ms_error	MAIN MENU\Maint\M_MSTSLV	12	RO	Maintenance Display Tables\MSTSLAVE
Master/Slave Select	ms_sel	MAIN MENU\Config\MST_SLV	3	RW	Configuration Tables\MST_SLV
Max Available Capacity?	cap_max	MAIN MENU\Maint\M_MSTSLV	13	RO	Maintenance Display Tables\MSTSLAVE
Max Condenser LWT = 45C	max_clwt	MAIN MENU\Service\FACTORY	25	RW	Service Configuration Tables\FACTORY
MCHX Exchanger Select	mchx_sel	MAIN MENU\Service\FACTORY	15	RW	Service Configuration Tables\FACTORY
Metric Display on STDU	DISPUNIT	MAIN MENU\Config\DISPCONF	1	RW	Configuration Tables\DISPCONF
Minutes Left for Start	min_left	MAIN MENU>Status\GENUNIT	7	RO	Status Display Tables\GENUNIT
Model Number	ModelNum	MAIN MENU\Config\Ctr-ID	4	RO	Configuration Tables!\CtrlID\PD5_XAXQ
Must Trip Amps	cpa_mtam	MAIN MENU\Maint\BOARD_PN	12	RO	Maintenance Display Tables\BOARD_PN
Must Trip Amps	cpb_mtam	MAIN MENU\Maint\BOARD_PN	16	RO	Maintenance Display Tables\BOARD_PN
Must Trip Amps	cpc_mtam	MAIN MENU\Maint\BOARD_PN	20	RO	Maintenance Display Tables\BOARD_PN
Mean SST Calculation					
Circuit A	sst_dm_a	MAIN MENU\Maint\DEFROSTM	10	RO	Maintenance Display Tables\DEFROSTM
Circuit B	sst_dm_b	MAIN MENU\Maint\DEFROSTM	27	RO	Maintenance Display Tables\DEFROSTM
Motor Current					
Circuit A	CURREN_A	MAIN MENU>Status\CIRCA_AN	8	RO	Status Display Tables\CIRCA_AN
Circuit B	CURREN_B	MAIN MENU>Status\CIRCB_AN	8	RO	Status Display Tables\CIRCB_AN
Circuit C	CURREN_C	MAIN MENU>Status\CIRCC_AN	8	RO	Status Display Tables\CIRCC_AN

LEGEND

RW — Read/Write

RO — Read Only

**APPENDIX A — TOUCH PILOT™ DISPLAY TABLES (cont)**

TOUCH PILOT DESCRIPTION	TOUCH PILOT POINT NAME	TOUCH PILOT PATH	LINE	READ/ WRITE	CCN TABLE NAME
<b>Motor Temperature</b>					
Circuit A	CP_TMP_A	MAIN MENU\Status\CIRCA_AN	9	RO	Status Display Tables\CIRCA_AN
Circuit B	CP_TMP_B	MAIN MENU\Status\CIRCB_AN	9	RO	Status Display Tables\CIRCB_AN
Circuit C	CP_TMP_C	MAIN MENU\Status\CIRCC_AN	9	RO	Status Display Tables\CIRCC_AN
<b>Next Sequence Allowed in</b>					
Circuit A	def_se_a	MAIN MENU\Maint\DEFROSTM	20	RO	Maintenance Display Tables\DEFROSTM
Circuit B	def_se_b	MAIN MENU\Maint\DEFROSTM	20	RO	Maintenance Display Tables\DEFROSTM
<b>Oil Heater</b>					
Circuit A	Q_HT_A	MAIN MENU\Status\QCK_TST1	15	RW	Status Display Tables\QCK_TST1
Circuit B	Q_HT_B	MAIN MENU\Status\QCK_TST1	22	RW	Status Display Tables\QCK_TST1
Circuit C	Q_HT_C	MAIN MENU\Status\QCK_TST1	29	RW	Status Display Tables\QCK_TST1
<b>Oil Heater Output</b>					
Circuit A	OIL_HT_A	MAIN MENU\Status\CIRCA_D	5	RO	Status Display Tables\CIRCA_D
Circuit B	OIL_HT_B	MAIN MENU\Status\CIRCB_D	5	RO	Status Display Tables\CIRCB_D
Circuit C	OIL_HT_C	MAIN MENU\Status\CIRCC_D	5	RO	Status Display Tables\CIRCC_D
<b>Oil Level Input</b>					
Circuit A	OIL_L_A	MAIN MENU\Status\CIRCA_D	7	RO	Status Display Tables\CIRCA_D
Circuit B	OIL_L_B	MAIN MENU\Status\CIRCB_D	7	RO	Status Display Tables\CIRCB_D
Circuit C	OIL_L_C	MAIN MENU\Status\CIRCC_D	7	RO	Status Display Tables\CIRCC_D
<b>Oil Pressure</b>					
Circuit A	OP_A	MAIN MENU\Status\CIRCA_AN	6	RO	Status Display Tables\CIRCA_AN
Circuit B	OP_B	MAIN MENU\Status\CIRCB_AN	6	RO	Status Display Tables\CIRCB_AN
Circuit C	OP_C	MAIN MENU\Status\CIRCC_AN	6	RO	Status Display Tables\CIRCC_AN
<b>Oil Pressure Difference</b>					
Circuit A	DOP_A	MAIN MENU\Status\CIRCA_AN	7	RO	Status Display Tables\CIRCA_AN
Circuit B	DOP_B	MAIN MENU\Status\CIRCB_AN	7	RO	Status Display Tables\CIRCB_AN
Circuit C	DOP_C	MAIN MENU\Status\CIRCC_AN	7	RO	Status Display Tables\CIRCC_AN
<b>Oil Solenoid</b>					
Circuit A	Q_OILS_A	MAIN MENU\Status\QCK_TST1	16	RW	Status Display Tables\QCK_TST1
Circuit B	Q_OILS_B	MAIN MENU\Status\QCK_TST1	23	RW	Status Display Tables\QCK_TST1
Circuit C	Q_OILS_C	MAIN MENU\Status\QCK_TST1	30	RW	Status Display Tables\QCK_TST1
<b>Oil Solenoid Output</b>					
Circuit A	OIL_SL_A	MAIN MENU\Status\CIRCA_D	6	RO	Status Display Tables\CIRCA_D
Circuit B	OIL_SL_B	MAIN MENU\Status\CIRCB_D	6	RO	Status Display Tables\CIRCB_D
Circuit C	OIL_SL_C	MAIN MENU\Status\CIRCC_D	6	RO	Status Display Tables\CIRCC_D
<b>Optimal Fan Count</b>					
Circuit A	fancop_a	MAIN MENU\Maint\FANCTRL	4	RO	Maintenance Display Tables\FANCTRL
Circuit B	fancop_b	MAIN MENU\Maint\FANCTRL	8	RO	Maintenance Display Tables\FANCTRL
Circuit C	fancop_c	MAIN MENU\Maint\FANCTRL	12	RO	Maintenance Display Tables\FANCTRL
<b>Override State</b>					
Circuit A	over_d_a	MAIN MENU\Maint\DEFROSTM	8	RO	Maintenance Display Tables\DEFROSTM
Circuit B	over_d_b	MAIN MENU\Maint\DEFROSTM	25	RO	Maintenance Display Tables\DEFROSTM
<b>Percent Total Capacity</b>					
Circuit A	CAPA_T	MAIN MENU\Status\CIRCA_AN	2	RO	Status Display Tables\CIRCA_AN
Circuit B	CAPB_T	MAIN MENU\Status\CIRCB_AN	2	RO	Status Display Tables\CIRCB_AN
Circuit C	CAPC_T	MAIN MENU\Status\CIRCC_AN	2	RO	Status Display Tables\CIRCC_AN
<b>Pump Differential Press.</b>					
Circuit A	fc_dp_a	MAIN MENU\Status\FREECOOL	19	RO	Status Display Tables\FREECOOL
Circuit B	fc_dp_b	MAIN MENU\Status\FREECOOL	29	RO	Status Display Tables\FREECOOL
Circuit C	fc_dp_c	MAIN MENU\Status\FREECOOL	39	RO	Status Display Tables\FREECOOL
<b>Pump Inlet Pressure</b>					
Circuit A	fc_inp_a	MAIN MENU\Status\FREECOOL	17	RO	Status Display Tables\FREECOOL
Circuit B	fc_inp_b	MAIN MENU\Status\FREECOOL	27	RO	Status Display Tables\FREECOOL
Circuit C	fc_inp_c	MAIN MENU\Status\FREECOOL	37	RO	Status Display Tables\FREECOOL

LEGEND

RO — Read Only  
RW — Read/Write

**APPENDIX A — TOUCH PILOT™ DISPLAY TABLES (cont)**

TOUCH PILOT DESCRIPTION	TOUCH PILOT POINT NAME	TOUCH PILOT PATH	LINE	READ/ WRITE	CCN TABLE NAME
<b>Pump Inlet Pressure</b>					
Circuit A	fc_inp_a	MAIN MENU\Status\FREECOOL	17	RO	Status Display Tables\FREECOOL
Circuit B	fc_inp_b	MAIN MENU\Status\FREECOOL	27	RO	Status Display Tables\FREECOOL
Circuit C	fc_inp_c	MAIN MENU\Status\FREECOOL	37	RO	Status Display Tables\FREECOOL
<b>Pump Outlet Pressure</b>					
Circuit A	fc_oup_a	MAIN MENU\Status\FREECOOL	18	RO	Status Display Tables\FREECOOL
Circuit B	fc_oup_b	MAIN MENU\Status\FREECOOL	28	RO	Status Display Tables\FREECOOL
Circuit C	fc_oup_c	MAIN MENU\Status\FREECOOL	38	RO	Status Display Tables\FREECOOL
<b>NB Fans on Varifan Cir A</b>	varfan_a	MAIN MENU\Service\FACTORY	5	RW	Service Configuration Tables\FACTORY
<b>NB Fans on Varifan Cir B</b>	varfan_b	MAIN MENU\Service\FACTORY	6	RW	Service Configuration Tables\FACTORY
<b>NB Fans on Varifan Cir C</b>	varfan_c	MAIN MENU\Service\FACTORY	7	RW	Service Configuration Tables\FACTORY
<b>Next Occupied Day</b>	NXTOCDAY	MAIN MENU\Maint\OCCDEFM\OCC1PO1S	7	RO	Maintenance Display Tables\OCCDEFM\OCC1PO1S
<b>Next Occupied Day</b>	NXTOCDAY	MAIN MENU\Maint\OCCDEFM\OCC2PO2S	7	RO	Maintenance Display Tables\OCCDEFM\OCC2PO2S
<b>Next Occupied Time</b>	NXTOCTIM	MAIN MENU\Maint\OCCDEFM\OCC1PO1S	8	RO	Maintenance Display Tables\OCCDEFM\OCC1PO1S
<b>Next Occupied Time</b>	NXTOCTIM	MAIN MENU\Maint\OCCDEFM\OCC2PO2S	8	RO	Maintenance Display Tables\OCCDEFM\OCC2PO2S
<b>Next Session Allowed In</b>	fc_next	MAIN MENU\Status\FREECOOL	6	RO	Status Display Tables\FREECOOL
<b>Next Unoccupied Day</b>	NXTUNDAY	MAIN MENU\Maint\OCCDEFM\OCC1PO1S	9	RO	Maintenance Display Tables\OCCDEFM\OCC1PO1S
<b>Next Unoccupied Day</b>	NXTUNDAY	MAIN MENU\Maint\OCCDEFM\OCC2PO2S	9	RO	Maintenance Display Tables\OCCDEFM\OCC2PO2S
<b>Next Unoccupied Time</b>	NXTUNTIM	MAIN MENU\Maint\OCCDEFM\OCC1PO1S	10	RO	Maintenance Display Tables\OCCDEFM\OCC1PO1S
<b>Next Unoccupied Time</b>	NXTUNTIM	MAIN MENU\Maint\OCCDEFM\OCC2PO2S	10	RO	Maintenance Display Tables\OCCDEFM\OCC2PO2S
<b>Night Control Capacity Limit</b>	nh_limit	MAIN MENU\Config\USER	41	RW	Configuration Tables\USER
<b>Night Control End Hour</b>	nh_end	MAIN MENU\Config\USER	40	RW	Configuration Tables\USER
<b>Night Control Start Hour</b>	nh_start	MAIN MENU\Config\USER	39	RW	Configuration Tables\USER
<b>Night Low Noise Active</b>	Mode_09	MAIN MENU\Status\MODES	10	RO	Status Display Tables\MODES
<b>OAT Broadcast Bus #</b>	oatbusnm	MAIN MENU\Config\BRODEFS	4	RW	Configuration Tables\BRODEFS\BROCASTS
<b>OAT Broadcast Element #</b>	oatlocad	MAIN MENU\Config\BRODEFS	5	RW	Configuration Tables\BRODEFS\BROCASTS
<b>OAT Full Reset Value</b>	oatcr_fu	MAIN MENU\Setpoint\SETPOINT	6	RW	Setpoint Configuration Tables\SETPOINT
<b>OAT Full Reset Value</b>	oathr_fu	MAIN MENU\Setpoint\SETPOINT	20	RW	Setpoint Configuration Tables\SETPOINT
<b>OAT No Reset Value</b>	oatcr_no	MAIN MENU\Setpoint\SETPOINT	5	RW	Setpoint Configuration Tables\SETPOINT
<b>OAT No Reset Value</b>	oathr_no	MAIN MENU\Setpoint\SETPOINT	19	RW	Setpoint Configuration Tables\SETPOINT
<b>Occupied From</b>	OCCOD#	MAIN MENU\Schedule\OCCPC01S	3	RO	Configuration Tables\OCCPC01S
<b>Occupied Override Switch</b>	OCC_OVSW	MAIN MENU\Status\STATEGEN	10	RO	Status Display Tables\STATEGEN
<b>Occupied To</b>	UNOCTOD#	MAIN MENU\Schedule\OCCPC01S	4	RO	Configuration Tables\OCCPC01S
<b>Oil Filter A Ctrl (days)</b>	oilfil_a	MAIN MENU\Service\MAINTCFG	10	RW	Service Configuration Tables\MAINTCFG
<b>Oil Filter B Ctrl (days)</b>	oilfil_b	MAIN MENU\Service\MAINTCFG	11	RW	Service Configuration Tables\MAINTCFG
<b>Oil Filter C Ctrl (days)</b>	oilfil_c	MAIN MENU\Service\MAINTCFG	12	RW	Service Configuration Tables\MAINTCFG
<b>On/Off - Remote Switch</b>	ONOFF_SW	MAIN MENU\Status\STATEGEN	2	RO	Status Display Tables\STATEGEN
<b>OP WARN 1- Refrigerant Charge</b>	charge_m	MAIN MENU\Maint\SERMAINT	6	RO	Maintenance Display Tables\SERMAINT
<b>OP WARN 2 - Water Loop Size</b>	wloop_m	MAIN MENU\Maint\SERMAINT	7	RO	Maintenance Display Tables\SERMAINT
<b>Operating Type</b>	OPER_TYP	MAIN MENU\Status\GENUNIT	2	RO	Status Display Tables\GENUNIT
<b>Optional Space temp</b>	SPACETMP	MAIN MENU\Status\STATEGEN	39	RO	Status Display Tables\STATEGEN
<b>Pass for All User Config</b>	all_pass	MAIN MENU\Config\USER	44	RW	Configuration Tables\USER
<b>Percent Total Capacity</b>	CAP_T	MAIN MENU\Status\GENUNIT	20	RO	Status Display Tables\GENUNIT
<b>Period # DOW (MTWTFSSH)</b>	DOW#	MAIN MENU\Schedule\OCCPC01S	2	RO	Configuration Tables\OCCPC01S

LEGEND

RO — Read Only  
RW — Read/Write



**APPENDIX A — TOUCH PILOT™ DISPLAY TABLES (cont)**

TOUCH PILOT DESCRIPTION	TOUCH PILOT POINT NAME	TOUCH PILOT PATH	LINE	READ/ WRITE	CCN TABLE NAME
Pinch offset circuit A	p_ofst_a	MAIN MENU\Service\SERVICE1	12	RW	Service Configuration Tables\SERVICE1
Pinch offset circuit B	p_ofst_b	MAIN MENU\Service\SERVICE1	13	RW	Service Configuration Tables\SERVICE1
Pinch offset circuit C	p_ofst_c	MAIN MENU\Service\SERVICE1	14	RW	Service Configuration Tables\SERVICE1
Power Down 1: day-mon-year	date_of1	MAIN MENU\Maint\LAST_POR	3	RO	Maintenance Display Tables\LAST_POR
Power Down 1: hour-minute	time_of1	MAIN MENU\Maint\LAST_POR	4	RO	Maintenance Display Tables\LAST_POR
Power Down 2: day-mon-year	date_of2	MAIN MENU\Maint\LAST_POR	7	RO	Maintenance Display Tables\LAST_POR
Power Down 2: hour-minute	time_of2	MAIN MENU\Maint\LAST_POR	8	RO	Maintenance Display Tables\LAST_POR
Power Down 3: day-mon-year	date_of3	MAIN MENU\Maint\LAST_POR	11	RO	Maintenance Display Tables\LAST_POR
Power Down 3: hour-minute	time_of3	MAIN MENU\Maint\LAST_POR	12	RO	Maintenance Display Tables\LAST_POR
Power Down 4: day-mon-year	date_of4	MAIN MENU\Maint\LAST_POR	15	RO	Maintenance Display Tables\LAST_POR
Power Down 4: hour-minute	time_of4	MAIN MENU\Maint\LAST_POR	16	RO	Maintenance Display Tables\LAST_POR
Power Down 5: day-mon-year	date_of5	MAIN MENU\Maint\LAST_POR	19	RO	Maintenance Display Tables\LAST_POR
Power Down 5: hour-minute	time_of5	MAIN MENU\Maint\LAST_POR	20	RO	Maintenance Display Tables\LAST_POR
Power Frequency 60HZ Sel	freq_60H	MAIN MENU\Service\FACTORY	3	RW	Service Configuration Tables\FACTORY
Power On 1: day-mon-year	date_on1	MAIN MENU\Maint\LAST_POR	1	RO	Maintenance Display Tables\LAST_POR
Power On 1: hour-minute	time_on1	MAIN MENU\Maint\LAST_POR	2	RO	Maintenance Display Tables\LAST_POR
Power On 2: day-mon-year	date_on2	MAIN MENU\Maint\LAST_POR	5	RO	Maintenance Display Tables\LAST_POR
Power On 2: hour-minute	time_on2	MAIN MENU\Maint\LAST_POR	6	RO	Maintenance Display Tables\LAST_POR
Power On 3: day-mon-year	date_on3	MAIN MENU\Maint\LAST_POR	9	RO	Maintenance Display Tables\LAST_POR
Power On 3: hour-minute	time_on3	MAIN MENU\Maint\LAST_POR	10	RO	Maintenance Display Tables\LAST_POR
Power On 4: day-mon-year	date_on4	MAIN MENU\Maint\LAST_POR	13	RO	Maintenance Display Tables\LAST_POR
Power On 4: hour-minute	time_on4	MAIN MENU\Maint\LAST_POR	14	RO	Maintenance Display Tables\LAST_POR
Power On 5: day-mon-year	date_on5	MAIN MENU\Maint\LAST_POR	17	RO	Maintenance Display Tables\LAST_POR
Power On 5: hour-minute	time_on5	MAIN MENU\Maint\LAST_POR	18	RO	Maintenance Display Tables\LAST_POR
Power Supply Voltage	voltage	MAIN MENU\Service\FACTORY	4	RW	Service Configuration Tables\FACTORY
Prev unoccupied Day	PRVUNDAY	MAIN MENU\Maint\OCCDEFCM\OCC1PO1S	11	RO	Maintenance Display Tables\OCCDEFCM\OCC1PO1S
Prev unoccupied Day	PRVUNDAY	MAIN MENU\Maint\OCCDEFCM\OCC2PO2S	11	RO	Maintenance Display Tables\OCCDEFCM\OCC2PO2S
Prev unoccupied Time	PRVUNTIM	MAIN MENU\Maint\OCCDEFCM\OCC1PO1S	12	RO	Maintenance Display Tables\OCCDEFCM\OCC1PO1S
Prev unoccupied Time	PRVUNTIM	MAIN MENU\Maint\OCCDEFCM\OCC2PO2S	12	RO	Maintenance Display Tables\OCCDEFCM\OCC2PO2S
Prop PID Gain Varifan	hd_pg	MAIN MENU\Service\SERVICE1	6	RW	Service Configuration Tables\SERVICE1
Pump Auto Rotation Delay	pump_del	MAIN MENU\Config\USER	14	RW	Configuration Tables\USER
Pump Periodic Start	Mode_08	MAIN MENU>Status\MODES	9	RO	Status Display Tables\MODES
Pump Sticking Protection	pump_per	MAIN MENU\Config\USER	15	RW	Configuration Tables\USER
Pumpdown Pressure Cir A	PD_P_A	MAIN MENU>Status\RECLAIM	11	RO	Status Display Tables\RECLAIM
Pumpdown Pressure Cir B	PD_P_B	MAIN MENU>Status\RECLAIM	21	RO	Status Display Tables\RECLAIM
Pumpdown Saturated Tmp A	hr_sat_a	MAIN MENU>Status\RECLAIM	13	RO	Status Display Tables\RECLAIM
Pumpdown Saturated Tmp B	hr_sat_b	MAIN MENU>Status\RECLAIM	23	RO	Status Display Tables\RECLAIM
Quick EHS for Defrost	ehs_defr	MAIN MENU\Config\USER	37	RW	Configuration Tables\USER
Quick Test Enable	Q_TSTRQ	MAIN MENU>Status\QCK_TST1	1	RW	Status Display Tables\QCK_TST1
Quick Test Enable	Q_TSTRQ	MAIN MENU>Status\QCK_TST2	1	RW	Status Display Tables\QCK_TST2
Ramp Loading Active	Mode_05	MAIN MENU>Status\MODES	6	RO	Status Display Tables\MODES
Ramp Loading Select	ramp_sel	MAIN MENU\Config\USER	5	RW	Configuration Tables\USER
Ready or Running Status	READY	MAIN MENU>Status\STATEGEN	30	RO	Status Display Tables\STATEGEN
Realarm Time	RE_ALARM	MAIN MENU\Config\ALARMDEF	4	RW	Configuration Tables\ALARMDEF\ALARMS01
Recl Valve Max Position	max_3w	MAIN MENU\Service\SERVICE1	20	RW	Service Configuration Tables\SERVICE1
Recl Valve Min Position	min_3w	MAIN MENU\Service\SERVICE1	19	RW	Service Configuration Tables\SERVICE1
Reclaim Active	Mode_14	MAIN MENU>Status\MODES	15	RO	Status Display Tables\MODES
Reclaim Condenser Flow	CONDFLOW	MAIN MENU>Status\RECLAIM	3	RO	Status Display Tables\RECLAIM
Reclaim Condenser Heater	cond_htr	MAIN MENU>Status\RECLAIM	4	RO	Status Display Tables\RECLAIM
Reclaim Condenser Pump	HPUMP_1	MAIN MENU>Status\RECLAIM	2	RO	Status Display Tables\RECLAIM

**LEGEND**

**RO** — Read Only  
**RW** — Read/Write

**APPENDIX A — TOUCH PILOT™ DISPLAY TABLES (cont)**

TOUCH PILOT DESCRIPTION	TOUCH PILOT POINT NAME	TOUCH PILOT PATH	LINE	READ/ WRITE	CCN TABLE NAME
Reclaim Deadband	hr_deadb	MAIN MENU\Setpoint\SETPOINT	37	RW	Setpoint Configuration Tables\SETPOINT
Reclaim Entering Fluid	HR_EWT	MAIN MENU>Status\RECLAIM	5	RO	Status Display Tables\RECLAIM
Reclaim Fluid Setpoint	RSP	MAIN MENU>Status\RECLAIM	7	RO	Status Display Tables\RECLAIM
Reclaim Leaving Fluid	HR_LWT	MAIN MENU>Status\RECLAIM	6	RO	Status Display Tables\RECLAIM
Reclaim NRCP2 Board	REC_NRCP	MAIN MENU\Maint\BOARD_PN	10	RO	Maintenance Display Tables\BOARD_PN
Reclaim Setpoint	rsp	MAIN MENU\Setpoint\SETPOINT	36	RW	Setpoint Configuration Tables\SETPOINT
Reclaim Status Circuit A	hrstat_a	MAIN MENU>Status\RECLAIM	10	RO	Status Display Tables\RECLAIM
Reclaim Status Circuit B	hrstat_b	MAIN MENU>Status\RECLAIM	20	RO	Status Display Tables\RECLAIM
Reclaim Valve Position	hr_v_pos	MAIN MENU>Status\RECLAIM	8	RO	Status Display Tables\RECLAIM
Reference Number	RefNum	MAIN MENU\Config\Ctr-ID	6	RO	Configuration Tables\CtrID\PD5_XAXQ
Refrigerant Charge Ctrl	charge_c	MAIN MENU\Service\MAINTCFG	3	RW	Service Configuration Tables\MAINTCFG
Remote Heat/Cool Switch	HC_SW	MAIN MENU>Status\STATEGEN	3	RO	Status Display Tables\STATEGEN
Remote Interlock Status	REM_LOCK	MAIN MENU>Status\STATEGEN	15	RO	Status Display Tables\STATEGEN
Remote Reclaim Switch	RECL_SW	MAIN MENU>Status\STATEGEN	5	RO	Status Display Tables\STATEGEN
Remote Setpoint Switch	SETP_SW	MAIN MENU>Status\STATEGEN	7	RO	Status Display Tables\STATEGEN
Requested Electric Stage	eh_stage	MAIN MENU\Maint\LOADFACT	23	RO	Maintenance Display Tables\LOADFACT
Reset Amount	reset	MAIN MENU\Maint\LOADFACT	6	RO	Maintenance Display Tables\LOADFACT
Reset in Effect	Mode_03	MAIN MENU>Status\MODES	4	RO	Status Display Tables\MODES
Reset Maintenance Alert	S_RESET	MAIN MENU\Maint\SERMAINT	1	RO	Maintenance Display Tables\SERMAINT
Reset/Setpnt 4-20mA Sgnl	SP_RESET	MAIN MENU>Status\STATEGEN	41	RO	Status Display Tables\STATEGEN
Reverse Alarms Relay	al_rever	MAIN MENU\Config\USER	43	RW	Configuration Tables\USER
Rotate Condenser Pumps?	ROTHPUMP	MAIN MENU>Status\STATEGEN	25	RO	Status Display Tables\STATEGEN
Rotate Cooler Pumps?	ROTCPUMP	MAIN MENU>Status\STATEGEN	22	RO	Status Display Tables\STATEGEN
Run Status	STATUS	MAIN MENU>Status\GENUNIT	4	RO	Status Display Tables\GENUNIT
Running Status	RUNNING	MAIN MENU>Status\STATEGEN	31	RO	Status Display Tables\STATEGEN
Reference Delta					
Circuit A	delt_r_a	MAIN MENU\Maint\DEFROSTM	12	RO	Maintenance Display Tables\DEFROSTM
Circuit B	delt_r_b	MAIN MENU\Maint\DEFROSTM	29	RO	Maintenance Display Tables\DEFROSTM
Refrigerant Pump Out					
Circuit A	FC_PMP_A	MAIN MENU>Status\FREECOOL	16	RO	Status Display Tables\FREECOOL
Circuit B	FC_PMP_B	MAIN MENU>Status\FREECOOL	26	RO	Status Display Tables\FREECOOL
Circuit C	FC_PMP_C	MAIN MENU>Status\FREECOOL	36	RO	Status Display Tables\FREECOOL
Running Output					
Circuit A	Q_RUN_A	MAIN MENU>Status\QCK_TST1	43	RW	Status Display Tables\QCK_TST1
Circuit B	Q_RUN_B	MAIN MENU>Status\QCK_TST1	44	RW	Status Display Tables\QCK_TST1
Circuit C	Q_RUN_C	MAIN MENU>Status\QCK_TST1	45	RW	Status Display Tables\QCK_TST1
Saturated Condensing Tmp					
Circuit A	SCT_A	MAIN MENU>Status\CIRCA_AN	12	RO	Status Display Tables\CIRCA_AN
Circuit B	SCT_B	MAIN MENU>Status\CIRCB_AN	12	RO	Status Display Tables\CIRCB_AN
Circuit C	SCT_C	MAIN MENU>Status\CIRCC_AN	12	RO	Status Display Tables\CIRCC_AN
Saturated Suction Temp					
Circuit A	SST_A	MAIN MENU>Status\CIRCA_AN	13	RO	Status Display Tables\CIRCA_AN
Circuit B	SST_B	MAIN MENU>Status\CIRCB_AN	13	RO	Status Display Tables\CIRCB_AN
Circuit C	SST_C	MAIN MENU>Status\CIRCC_AN	13	RO	Status Display Tables\CIRCC_AN

LEGEND

RO — Read Only  
RW — Read/Write

**APPENDIX A — TOUCH PILOT™ DISPLAY TABLES (cont)**

TOUCH PILOT DESCRIPTION	TOUCH PILOT POINT NAME	TOUCH PILOT PATH	LINE	READ/ WRITE	CCN TABLE NAME
<b>SCT Candidate</b>					
Circuit A	sct_fu_a	MAIN MENU\Maint\FANCTRL	2	RO	Maintenance Display Tables\FANCTRL
Circuit B	sct_fu_b	MAIN MENU\Maint\FANCTRL	6	RO	Maintenance Display Tables\FANCTRL
Circuit C	sct_fu_c	MAIN MENU\Maint\FANCTRL	10	RO	Maintenance Display Tables\FANCTRL
<b>SCT Control Point</b>					
Circuit A	sct_sp_a	MAIN MENU\Maint\FANCTRL	1	RO	Maintenance Display Tables\FANCTRL
Circuit B	sct_sp_b	MAIN MENU\Maint\FANCTRL	5	RO	Maintenance Display Tables\FANCTRL
Circuit C	sct_sp_c	MAIN MENU\Maint\FANCTRL	9	RO	Maintenance Display Tables\FANCTRL
<b>Slide Valve 1</b>					
Circuit A	Q_SLI_1A	MAIN MENU>Status\QCK_TST1	17	RW	Status Display Tables\QCK_TST1
Circuit B	Q_SLI_1B	MAIN MENU>Status\QCK_TST1	24	RW	Status Display Tables\QCK_TST1
Circuit C	Q_SLI_1C	MAIN MENU>Status\QCK_TST1	31	RW	Status Display Tables\QCK_TST1
<b>Slide Valve 2</b>					
Circuit A	Q_SLI_2A	MAIN MENU>Status\QCK_TST1	18	RW	Status Display Tables\QCK_TST1
Circuit B	Q_SLI_2B	MAIN MENU>Status\QCK_TST1	25	RW	Status Display Tables\QCK_TST1
Circuit C	Q_SLI_2C	MAIN MENU>Status\QCK_TST1	32	RW	Status Display Tables\QCK_TST1
<b>Slide Valve 1 Output</b>					
Circuit A	SLID_1_A	MAIN MENU>Status\CIRCA_D	3	RO	Status Display Tables\CIRCA_D
Circuit B	SLID_1_B	MAIN MENU>Status\CIRCB_D	3	RO	Status Display Tables\CIRCB_D
Circuit C	SLID_1_C	MAIN MENU>Status\CIRCC_D	3	RO	Status Display Tables\CIRCC_D
<b>Slide Valve 2 Output</b>					
Circuit A	SLID_2_A	MAIN MENU>Status\CIRCA_D	4	RO	Status Display Tables\CIRCA_D
Circuit B	SLID_2_B	MAIN MENU>Status\CIRCB_D	4	RO	Status Display Tables\CIRCB_D
Circuit C	SLID_2_C	MAIN MENU>Status\CIRCC_D	4	RO	Status Display Tables\CIRCC_D
<b>Suction Pressure</b>					
Circuit A	SP_A	MAIN MENU>Status\CIRCA_AN	4	RO	Status Display Tables\CIRCA_AN
Circuit B	SP_B	MAIN MENU>Status\CIRCB_AN	4	RO	Status Display Tables\CIRCB_AN
Circuit C	SP_C	MAIN MENU>Status\CIRCC_AN	4	RO	Status Display Tables\CIRCC_AN
<b>S1 Config Switch (8 -&gt;1)</b>	cpa_s1_m	MAIN MENU\Maint\BOARD_PN	13	RO	Maintenance Display Tables\BOARD_PN
<b>S1 Config Switch (8 -&gt;1)</b>	cpb_s1_m	MAIN MENU\Maint\BOARD_PN	17	RO	Maintenance Display Tables\BOARD_PN
<b>S1 Config Switch (8 -&gt;1)</b>	cpc_s1_m	MAIN MENU\Maint\BOARD_PN	21	RO	Maintenance Display Tables\BOARD_PN
<b>Second Setpoint in Use</b>	Mode_02	MAIN MENU>Status\MODES	3	RO	Status Display Tables\MODES
<b>Serial Number</b>	SerialNo	MAIN MENU\Config\CtrID	5	RO	Configuration Tables!\CtrlID\PD5_XAXQ
<b>Service Test Enable</b>	Q_STREQ	MAIN MENU>Status\SERV_TST	1	RW	Status Display Tables\SERV_TST
<b>Servicing Alert</b>	s_alert	MAIN MENU\Service\MAINTCFG	2	RW	Service Configuration Tables\MAINTCFG
<b>Setpoint Control</b>	sp_ctrl	MAIN MENU>Status\GENUNIT	27	RO	Status Display Tables\GENUNIT
<b>Setpoint Occupied?</b>	SP_OCC	MAIN MENU>Status\GENUNIT	26	RO	Status Display Tables\GENUNIT
<b>Setpoint select</b>	sp_sel	MAIN MENU>Status\GENUNIT	25	RW	Status Display Tables\GENUNIT
<b>Shutdown Indicator State</b>	SHUTDOWN	MAIN MENU>Status\STATEGEN	27	RO	Status Display Tables\STATEGEN
<b>Slave Address</b>	slv_addr	MAIN MENU\Config\MST_SLV	11	RW	Configuration Tables\MST_SLV
<b>Slave Chiller State</b>	slv_stat	MAIN MENU\Maint\M_MSTSLV	6	RO	Maintenance Display Tables\MSTSLAVE
<b>Slave Chiller Total Cap</b>	slv_capt	MAIN MENU\Maint\M_MSTSLV	7	RO	Maintenance Display Tables\MSTSLAVE
<b>Slave lagstat</b>	lagstat	MAIN MENU\Maint\M_MSTSLV	14	RO	Maintenance Display Tables\MSTSLAVE
<b>Slide Valve Capacity A</b>	Q_SLIA	MAIN MENU>Status\SERV_TST	4	RW	Status Display Tables\SERV_TST
<b>Slide Valve Capacity B</b>	Q_SLIB	MAIN MENU>Status\SERV_TST	6	RW	Status Display Tables\SERV_TST
<b>Slide Valve Capacity C</b>	Q_SLIC	MAIN MENU>Status\SERV_TST	8	RW	Status Display Tables\SERV_TST
<b>Soft Starter Select</b>	softstar	MAIN MENU\Service\FACTORY	8	RW	Service Configuration Tables\FACTORY
<b>Software Part Number</b>	PartNum	MAIN MENU\Config\CtrID	3	RO	Configuration Tables!\CtrlID\PD5_XAXQ
<b>Space T Full Reset Value</b>	spacr_fu	MAIN MENU\Setpoint\SETPOINT	12	RW	Setpoint Configuration Tables\SETPOINT
<b>Space T No Reset Value</b>	spacr_no	MAIN MENU\Setpoint\SETPOINT	11	RW	Setpoint Configuration Tables\SETPOINT
<b>Staged Loading Sequence</b>	seq_typ	MAIN MENU\Config\USER	4	RW	Configuration Tables\USER
<b>Start if Error Higher</b>	start_dt	MAIN MENU\Config\MST_SLV	19	RW	Configuration Tables\MST_SLV
<b>Startup Delay in Effect</b>	Mode_01	MAIN MENU>Status\MODES	2	RO	Status Display Tables\MODES
<b>Stop Pump During Standby</b>	pump_sby	MAIN MENU\Config\USER	16	RW	Configuration Tables\USER

LEGEND

RO — Read Only  
RW — Read/Write

**APPENDIX A — TOUCH PILOT™ DISPLAY TABLES (cont)**

TOUCH PILOT DESCRIPTION	TOUCH PILOT POINT NAME	TOUCH PILOT PATH	LINE	READ/ WRITE	CCN TABLE NAME
Sub Condenser Temp Cir A	hr_subta	MAIN MENU\Status\RECLAIM	12	RO	Status Display Tables\RECLAIM
Sub Condenser Temp Cir B	hr_subtb	MAIN MENU\Status\RECLAIM	22	RO	Status Display Tables\RECLAIM
Subcooling Temperature A	hr_subca	MAIN MENU\Status\RECLAIM	14	RO	Status Display Tables\RECLAIM
Subcooling Temperature B	hr_subcb	MAIN MENU\Status\RECLAIM	24	RO	Status Display Tables\RECLAIM
Suction A Temp Average	sst_m_a	MAIN MENU\Maint\PR_LIMIT	4	RO	Maintenance Display Tables\PR_LIMIT
Suction B Temp Average	sst_m_b	MAIN MENU\Maint\PR_LIMIT	8	RO	Maintenance Display Tables\PR_LIMIT
Suction C Temp Average	sst_m_c	MAIN MENU\Maint\PR_LIMIT	12	RO	Maintenance Display Tables\PR_LIMIT
Suction SH Control Pt A	sh_sp_a	MAIN MENU\Maint\EXV_CTRL	5	RO	Maintenance Display Tables\EXV_CTRL
Suction SH Control Pt B	sh_sp_b	MAIN MENU\Maint\EXV_CTRL	12	RO	Maintenance Display Tables\EXV_CTRL
Suction SH Control Pt C	sh_sp_c	MAIN MENU\Maint\EXV_CTRL	19	RO	Maintenance Display Tables\EXV_CTRL
Suction Superheat A	SH_A	MAIN MENU\Maint\EXV_CTRL	4	RO	Maintenance Display Tables\EXV_CTRL
Suction Superheat B	SH_B	MAIN MENU\Maint\EXV_CTRL	11	RO	Maintenance Display Tables\EXV_CTRL
Suction Superheat C	SH_C	MAIN MENU\Maint\EXV_CTRL	18	RO	Maintenance Display Tables\EXV_CTRL
Switch Limit Setpoint 1	lim_sp1	MAIN MENU\Setpoint\SETPOINT	33	RW	Setpoint Configuration Tables\SETPOINT
Switch Limit Setpoint 2	lim_sp2	MAIN MENU\Setpoint\SETPOINT	34	RW	Setpoint Configuration Tables\SETPOINT
Switch Limit Setpoint 3	lim_sp3	MAIN MENU\Setpoint\SETPOINT	35	RW	Setpoint Configuration Tables\SETPOINT
System Manager Active	Mode_10	MAIN MENU\Status\MODES	11	RO	Status Display Tables\MODES
TCPM Board Comp A	cpa_vers	MAIN MENU\Maint\BOARD_PN	11	RO	Maintenance Display Tables\BOARD_PN
TCPM Board Comp B	cpb_vers	MAIN MENU\Maint\BOARD_PN	15	RO	Maintenance Display Tables\BOARD_PN
TCPM Board Comp C	cpc_vers	MAIN MENU\Maint\BOARD_PN	19	RO	Maintenance Display Tables\BOARD_PN
Timed Override Hours	OVR_EXT	Configuration Tables\OCCPC01S	1	RO	Configuration Tables\OCCPC01S
Timed Override Hours	OVR_EXT	MAIN MENU\Schedule\OCCPC02S	1	RO	Configuration Tables\OCCPC02S
Timed-Override Duration	OVE_HRS	MAIN MENU\Maint\OCCDEFM\OCC1PO1S	4	RO	Maintenance Display Tables\OCCDEFM\OCC1PO1S
Timed-Override Duration	OVE_HRS	MAIN MENU\Maint\OCCDEFM\OCC2PO2S	4	RO	Maintenance Display Tables\OCCDEFM\OCC2PO2S
Timed-Override in Effect	OVERLAST	MAIN MENU\Maint\OCCDEFM\OCC1PO1S	3	RO	Maintenance Display Tables\OCCDEFM\OCC1PO1S
Timed-Override in Effect	OVERLAST	MAIN MENU\Maint\OCCDEFM\OCC2PO2S	3	RO	Maintenance Display Tables\OCCDEFM\OCC2PO2S
<b>Total Fans NB</b>					
Circuit A	nb_fan_a	MAIN MENU\Service\FACTORY2	14	RW	Service Configuration Tables\FACTORY2
Circuit B	nb_fan_b	MAIN MENU\Service\FACTORY2	15	RW	Service Configuration Tables\FACTORY2
Circuit C	nb_fan_c	MAIN MENU\Service\FACTORY2	16	RW	Service Configuration Tables\FACTORY2
Unit Capacity Model	unitsize	MAIN MENU\Service\FACTORY	2	RW	Service Configuration Tables\FACTORY
Unit is Master or Slave	mstslv	MAIN MENU\Maint\M_MSTSLV	2	RO	Maintenance Display Tables\MSTSLAVE
Unit Off to On Delay	off_on_d	MAIN MENU\Config\USER	6	RW	Configuration Tables\USER
Unit Type (Heat Pump=2)	unit_typ	MAIN MENU\Service\FACTORY	1	RW	Service Configuration Tables\FACTORY
Use Password	use_pass	MAIN MENU\Service\SERVICE1	24	RW	Service Configuration Tables\SERVICE1
Valve Actuators Heaters	FC_HTR	MAIN MENU\Status\FREECOOL	10	RO	Status Display Tables\FREECOOL
VLT Fan Drive Select	vlt_set	MAIN MENU\Service\FACTORY	22	RW	Service Configuration Tables\FACTORY
VLT Fan Drive RPM	vlt_rpm	MAIN MENU\Service\FACTORY	23	RW	Service Configuration Tables\FACTORY
Water Cond Enter Valv A	Q_HREW_A	MAIN MENU\Status\QCK_TST2	5	RW	Status Display Tables\QCK_TST2
Water Cond Enter Valv B	Q_HREW_B	MAIN MENU\Status\QCK_TST2	9	RW	Status Display Tables\QCK_TST2
Water Cond Enter Valve A	hr_ew_a	MAIN MENU\Status\RECLAIM	16	RO	Status Display Tables\RECLAIM
Water Cond Enter Valve B	hr_ew_b	MAIN MENU\Status\RECLAIM	26	RO	Status Display Tables\RECLAIM
Water Cond Leav Valve B	Q_HRLW_B	MAIN MENU\Status\QCK_TST2	10	RW	Status Display Tables\QCK_TST2
Water Cond Leaving Valve A	hr_lw_a	MAIN MENU\Status\RECLAIM	18	RO	Status Display Tables\RECLAIM
Water Cond Leaving Valve B	hr_lw_b	MAIN MENU\Status\RECLAIM	28	RO	Status Display Tables\RECLAIM
Water Delta T	delta_t	MAIN MENU\Maint\LOADFACT	4	RO	Maintenance Display Tables\LOADFACT
Water Exchanger Pump 1	Q_PMP1	MAIN MENU\Status\QCK_TST1	37	RW	Status Display Tables\QCK_TST1
Water Exchanger Pump 2	Q_PMP2	MAIN MENU\Status\QCK_TST1	38	RW	Status Display Tables\QCK_TST1
Water Filter Ctrl (days)	wfilte_c	MAIN MENU\Service\MAINTCFG	9	RW	Service Configuration Tables\MAINTCFG
Water Loop Control	wloop_c	MAIN MENU\Service\MAINTCFG	4	RW	Service Configuration Tables\MAINTCFG
Water Pump #1 Hours	hr_cpum1	MAIN MENU\Service\UPDTHOUR	13	RW	Service Configuration Tables\UPDTHOUR
Water Pump #2 Hours	hr_cpum2	MAIN MENU\Service\UPDTHOUR	14	RW	Service Configuration Tables\UPDTHOUR
Water Val Condensing Stp	w_sct_sp	MAIN MENU\Setpoint\SETPOINT	38	RW	Setpoint Configuration Tables\SETPOINT
Watre Cond Leav Valve A	Q_HRLW_A	MAIN MENU\Status\QCK_TST2	6	RW	Status Display Tables\QCK_TST2
Wye Delta Start Select	wye_delt	MAIN MENU\Service\FACTORY	9	RW	Service Configuration Tables\FACTORY

LEGEND

RO — Read Only  
RW — Read/Write

**APPENDIX B — NAVIGATOR™ DISPLAY TABLES**  
**MODE — RUN STATUS**

ITEM	EXPANSION	UNITS	RANGE	COMMENT	WRITE STATUS	CCN TABLE	CCN POINT	PAGE NO.
<b>VIEW</b>	AUTO DISPLAY							
→ <b>EWT</b>	Entering Fluid Temp	XXXX.X (deg F/deg C)	0-100			STATEGEN	COOL_EWT	10,48,69
→ <b>LWT</b>	Leaving Fluid Temp	XXX.X (deg F/deg C)	0-100			STATEGEN	COOL_LWT	10,48,49,69
→ <b>SETP</b>	Active Setpoint	XXX.X (deg F/deg C)	0-100			GENUNIT	SP	38,69
→ <b>CTPT</b>	Control Point	XXX.X (deg F/deg C)	0-100			GENUNIT	CTRL_PNT	38,48,49,59,69
→ <b>STAT</b>	Unit Run Status		Off Running Stopping Delay			GENUNIT	STATUS	25,27,105
→ <b>OCC</b>	Occupied		NO/YES			GENUNIT	CHIL_OCC	25,27
→ <b>CTRL</b>	Status Unit Control Type		Local Off Local On CCN Remote			GENUNIT GENUNIT	ctr_type	25,27
→ <b>CAP</b>	Percent Total Capacity	XXX (%)	0-100			GENUNIT	CAP_T	
→ <b>CAP.A</b>	Percent Capacity Cir A	XXX (%)	0-100			GENUNIT	CAPA_T	
→ <b>CAP.B</b>	Percent Capacity Cir B	XXX (%)	0-100			GENUNIT	CAPB_T	
→ <b>CAP.C</b>	Percent Capacity Cir C	XXX (%)	0-100			GENUNIT	CAPC_T	
→ <b>CAP.S</b>	Capacity Indicator	XX	0-32			LOADFACT	OVER_CAPLC	47
→ <b>LIM</b>	Active Demand Limit Val	XXX (%)	0-100			GENUNIT	DEM-LIM	69
→ <b>CURR</b>	Actual Chiller Current	XXX (amps)	0-4000			GENUNIT	TOT_CURR	
→ <b>CUR.L</b>	Chiller Current Limit	XXX (amps)	0-4000			GENUNIT	CURR_LIM	
→ <b>ALRM</b>	Alarm State		0=Normal 1=Partial 2=Shutdown DSBL/ENBL			GENUNIT GENUNIT GENUNIT	ALM	
→ <b>EMGY</b>	Emergency Stop		DSBL/ENBL			GENUNIT	EMSTOP	
→ <b>CH.SS</b>	CCN Chiller Start Stop		DSBL/ENBL	Standby not supported.		GENUNIT GENUNIT	CHILL_S_S	49
→ <b>HC.ST</b>	Heat Cool Status		0=Cooling 1=Heating 2=Standby			GENUNIT	HEATCOOL	
→ <b>RC.ST</b>	Reclaim Select Status		NO/YES	Not supported.		GENUNIT	reclaim_sel	
→ <b>TIME</b>	Time of Day	XX.XX	00:00-23:59			N/A	TIME	
→ <b>MNTH</b>	Month of Year		1=January 2=February 3=March 4=April 6=May 6=June 7=July 8=August 9=September 10=October 11=November 12=December			N/A N/A	moy	
→ <b>DATE</b>	Day of Month	XX	1-31			N/A	dom	
→ <b>YEAR</b>	Year of Century	XX	00-99			N/A	yoc	
<b>RUN</b>	<b>MACHINE STARTS/HOURS</b>							
→ <b>HRS.U</b>	Machine Operating Hours	XXXX (hours)	0-999999*		forcible	STRTHOUR	hr_mach	
→ <b>STR.U</b>	Machine Starts	XXXX	0-999999*		forcible	STRTHOUR	st_mach	
→ <b>HR.P1</b>	Water Pump 1 Run Hours	XXXX (hours)	0-999999*		forcible	STRTHOUR	hr_cpum1	
→ <b>HR.P2</b>	Water Pump 2 Run Hours	XXXX (hours)	0-999999*		forcible	STRTHOUR	hr_cpum2	
→ <b>HR.P3</b>	Condenser Pump 1 Hours	XXXX (hours)	0-999999*		forcible	STRTHOUR	hr_hpump1	
<b>HOUR</b>	<b>COMPRESSOR RUN HOURS</b>							
→ <b>HR.A</b>	Compressor A Run Hours	XXXX (hours)	0-999999*		forcible	STRTHOUR	hr_cp_a	
→ <b>HR.B</b>	Compressor B Run Hours	XXXX (hours)	0-999999*		forcible	STRTHOUR	hr_cp_b	
→ <b>HR.C</b>	Compressor C Run Hours	XXXX (hours)	0-999999*		forcible	STRTHOUR	hr_cp_c	
<b>STRT</b>	<b>COMPRESSOR STARTS</b>							
→ <b>ST.A</b>	Compressor A Starts	XXXX	0-999999*		forcible	STRTHOUR	st_cp_a	
→ <b>ST.B</b>	Compressor B Starts	XXXX	0-999999*		forcible	STRTHOUR	st_cp_b	
→ <b>ST.C</b>	Compressor C Starts	XXXX	0-999999*		forcible	STRTHOUR	st_cp_c	

\*As data in all of these categories can exceed 9999 the following display strategy is used:  
 From 0-9999 display as 4 digits.  
 From 9999-99999 display xx.xK  
 From 99900-999999 display as xxxK.

## APPENDIX B — NAVIGATOR™ DISPLAY TABLES (cont)

### MODE — RUN STATUS (cont)

ITEM	EXPANSION	UNITS	RANGE	COMMENT	WRITE STATUS	CCN TABLE	CCN POINT	PAGE NO.
<b>FAN</b>	<b>FAN RUN HOURS</b>							
→ <b>FR.A1</b>	Fan 1 Run Hours Cir A	XXXX (hours)	0-999999*	Not supported.	forcible	FANHOURS	hr_fana1	
→ <b>FR.A2</b>	Fan 2 Run Hours Cir A	XXXX (hours)	0-999999*	Not supported.	forcible	FANHOURS	hr_fana2	
→ <b>FR.A3</b>	Fan 3 Run Hours Cir A	XXXX (hours)	0-999999*	Not supported.	forcible	FANHOURS	hr_fana3	
→ <b>FR.A4</b>	Fan 4 Run Hours Cir A	XXXX (hours)	0-999999*	Not supported.	forcible	FANHOURS	hr_fana4	
→ <b>FR.A5</b>	Fan 5 Run Hours Cir A	XXXX (hours)	0-999999*	Not supported.	forcible	FANHOURS	hr_fana5	
→ <b>FR.A6</b>	Fan 6 Run Hours Cir A	XXXX (hours)	0-999999*	Not supported.	forcible	FANHOURS	hr_fana6	
→ <b>FR.A7</b>	Fan 7 Run Hours Cir A	XXXX (hours)	0-999999*	Not supported.	forcible	FANHOURS	hr_fana7	
→ <b>FR.A8</b>	Fan 8 Run Hours Cir A	XXXX (hours)	0-999999*	Not supported.	forcible	FANHOURS	hr_fana8	
→ <b>FR.A9</b>	Fan 9 Run Hours Cir A	XXXX (hours)	0-999999*	Not supported.	forcible	FANHOURS	hr_fana9	
→ <b>FA10</b>	Fan 10 Run Hours Cir A	XXXX (hours)	0-999999*	Not supported.	forcible	FANHOURS	hrfana10	
→ <b>FR.B1</b>	Fan 1 Run Hours Cir B	XXXX (hours)	0-999999*	Not supported.	forcible	FANHOURS	hr_fanb1	
→ <b>FR.B2</b>	Fan 2 Run Hours Cir B	XXXX (hours)	0-999999*	Not supported.	forcible	FANHOURS	hr_fanb2	
→ <b>FR.B3</b>	Fan 3 Run Hours Cir B	XXXX (hours)	0-999999*	Not supported.	forcible	FANHOURS	hr_fanb3	
→ <b>FR.B4</b>	Fan 4 Run Hours Cir B	XXXX (hours)	0-999999*	Not supported.	forcible	FANHOURS	hr_fanb4	
→ <b>FR.B5</b>	Fan 5 Run Hours Cir B	XXXX (hours)	0-999999*	Not supported.	forcible	FANHOURS	hr_fanb5	
→ <b>FR.B6</b>	Fan 6 Run Hours Cir B	XXXX (hours)	0-999999*	Not supported.	forcible	FANHOURS	hr_fanb6	
→ <b>FR.B7</b>	Fan 7 Run Hours Cir B	XXXX (hours)	0-999999*	Not supported.	forcible	FANHOURS	hr_fanb7	
→ <b>FR.B8</b>	Fan 8 Run Hours Cir B	XXXX (hours)	0-999999*	Not supported.	forcible	FANHOURS	hr_fanb8	
→ <b>FR.B9</b>	Fan 9 Run Hours Cir B	XXXX (hours)	0-999999*	Not supported.	forcible	FANHOURS	hr_fanb9	
→ <b>FB10</b>	Fan 10 Run Hours Cir B	XXXX (hours)	0-999999*	Not supported.	forcible	FANHOURS	hrfanb10	
→ <b>FR.C1</b>	Fan 1 Run Hours Cir C	XXXX (hours)	0-999999*	Not supported.	forcible	FANHOURS	hr_fanc1	
→ <b>FR.C2</b>	Fan 2 Run Hours Cir C	XXXX (hours)	0-999999*	Not supported.	forcible	FANHOURS	hr_fanc2	
→ <b>FR.C3</b>	Fan 3 Run Hours Cir C	XXXX (hours)	0-999999*	Not supported.	forcible	FANHOURS	hr_fanc3	
→ <b>FR.C4</b>	Fan 4 Run Hours Cir C	XXXX (hours)	0-999999*	Not supported.	forcible	FANHOURS	hr_fanc4	
→ <b>FR.C5</b>	Fan 5 Run Hours Cir C	XXXX (hours)	0-999999*	Not supported.	forcible	FANHOURS	hr_fanc5	
→ <b>FR.C6</b>	Fan 6 Run Hours Cir C	XXXX (hours)	0-999999*	Not supported.	forcible	FANHOURS	hr_fanc6	
→ <b>FR.C7</b>	Fan 7 Run Hours Cir C	XXXX (hours)	0-999999*	Not supported.	forcible	FANHOURS	hr_fanc7	
→ <b>FR.C8</b>	Fan 8 Run Hours Cir C	XXXX (hours)	0-999999*	Not supported.	forcible	FANHOURS	hr_fanc8	
→ <b>FR.C9</b>	Fan 9 Run Hours Cir C	XXXX (hours)	0-999999*	Not supported.	forcible	FANHOURS	hr_fanc8	
→ <b>FC10</b>	Fan 10 Run Hours Cir C	XXXX (hours)	0-999999*	Not supported.	forcible	FANHOURS	hr_fanc8	
<b>CP.UN</b>	<b>COMPRESSOR DISABLE</b>							
→ <b>A.UN</b>	Compressor A Disable		NO/YES		forcible	CP_UNABL	un_cp_a	
→ <b>B.UN</b>	Compressor B Disable		NO/YES		forcible	CP_UNABL	un_cp_b	
→ <b>C.UN</b>	Compressor C Disable		NO/YES		forcible	CP_UNABL	un_cp_c	
<b>MAIN</b>	<b>PREDICTIVE MAINTENANCE</b>							
→ <b>CHRG</b>	Refrigerant Charge		NO/YES			SERMAINT	charge_m	
→ <b>WATE</b>	Water Loop Size		NO/YES			SERMAINT	wloop_m	
→ <b>PMP.1</b>	Pump 1 (Days)	(days)				SERMAINT	cpump1_m	19
→ <b>PMP.2</b>	Pump 2 (Days)	(days)				SERMAINT	cpump2_m	19
→ <b>PMP.3</b>	Cond Pump 1 (Days)			Not supported.		SERMAINT	hpump1_m	
→ <b>PMP.4</b>	Cond Pump 2 (Days)			Not supported.		SERMAINT	hpump2_m	
→ <b>W.FIL</b>	Water Filter					SERMAINT	wfilte_m	
→ <b>A.FIL</b>	Comp A Oil Filter (days)	(days)				SERMAINT	ofilta_m	
→ <b>B.FIL</b>	Comp B Oil Filter (days)					SERMAINT	ofiltb_m	
→ <b>C.FIL</b>	Comp C Oil Filter (days)					SERMAINT	ofiltc_m	
<b>VERS</b>	<b>SOFTWARE VERSIONS</b>							
→ <b>APPL</b>	CSA-XXXXXXXXXX			Press ENTER and ESCAPE simultaneously to read version information		CntlID	PD5_APPL	
→ <b>MARQ</b>	XXXXXXXX-XX-XX						STDU	
→ <b>NAVI</b>	XXXXXXXX-XX-XX						Navigator	
→ <b>EXVA</b>	XXXXXXXX-XX-XX					BOARD_PN	EXV_BRDA	
→ <b>EXVB</b>	XXXXXXXX-XX-XX					BOARD_PN	EXV_BRDB	
→ <b>EXVC</b>	XXXXXXXX-XX-XX					BOARD_PN	EXV_BRDC	
→ <b>AUX1</b>	XXXXXXXX-XX-XX					BOARD_PN	AUX_BRD1	
→ <b>AUX2</b>	XXXXXXXX-XX-XX					BOARD_PN	AUX_BRD2	
→ <b>AUX3</b>	XXXXXXXX-XX-XX					BOARD_PN	AUX_BRD3	
→ <b>AUX4</b>	XXXXXXXX-XX-XX					BOARD_PN	AUX_BRD4	
→ <b>AUX5</b>	XXXXXXXX-XX-XX					BOARD_PN	AUX_BRD5	
→ <b>AUX6</b>	XXXXXXXX-XX-XX					BOARD_PN	AUX_BRD6	
→ <b>CPMA</b>	XXXXXXXX-XX-XX					BOARD_PN	SPM_CPA	
→ <b>CPMB</b>	XXXXXXXX-XX-XX					BOARD_PN	SPM_CPB	
→ <b>CPMC</b>	XXXXXXXX-XX-XX					BOARD_PN	SPM_CPC	
→ <b>EMM</b>	XXXXXXXX-XX-XX					BOARD_PN	EMM_NRCP	
→ <b>R.BRD</b>	XXXXXXXX-XX-XX					BOARD_PN	REC_NRCP	

\*As data in all of these categories can exceed 9999 the following display strategy is used:  
 From 0-9999 display as 4 digits.  
 From 9999-99999 display xx.xK  
 From 99900-999999 display as xxxK.

## APPENDIX B — NAVIGATOR™ DISPLAY TABLES (cont)

### MODE — SERVICE TEST

ITEM	EXPANSION	UNITS	RANGE	COMMENT	WRITE STATUS	CCN TABLE	CCN POINT	PAGE NO.
<b>TEST</b> → <b>T.REQ</b>	MANUAL TEST MODE Manual Sequence		OFF/ON	Remote-Off-Enable Switch must be set to <b>OFF</b> Position	forcible	SERV_TST SERV_TST	Q_STREQ	77, 104, 105
→ <b>CP.A</b>	Compressor A Output		OFF/ON	Remote-Off-Enable Switch must be set to <b>ENABLE</b> Position	forcible	SERV_TST	Q_CPA	77,78
→ <b>SLI.A</b>	Slide Valve Capacity A		unchanged increase decrease		forcible	SERV_TST	Q_SLIA	
→ <b>CP.B</b> → <b>SLI.B</b>	Compressor B Output Slide Valve Capacity B		OFF/ON unchanged increase decrease		forcible forcible	SERV_TST SERV_TST	Q_CPB Q_SLIB	77,78
→ <b>CP.C</b> → <b>SLI.C</b>	Compressor C Output Slide Valve Capacity C		OFF/ON unchanged increase decrease		forcible forcible	SERV_TST SERV_TST	Q_CPC Q_SLIC	77,78
<b>QUIC</b> → <b>Q.REQ</b>	QUICK TEST MODE		OFF/ON	Remote-Off-Enable Switch must be set to <b>OFF</b> Position	forcible	QCK_TST1 QCK_TST1	Q_TSTRQ	104, 106
→ <b>EXV.A</b>	Circuit A EXV % Open	XXX (%)	0-100		forcible	QCK_TST1	Q_EXVA	76,77
→ <b>EXV.B</b>	Circuit B EXV % Open	XXX (%)	0-100		forcible	QCK_TST1	Q_EXVB	76,77
→ <b>EXV.C</b>	Circuit C EXV % Open	XXX (%)	0-100		forcible	QCK_TST1	Q_EXVC	76,77
→ <b>ECO.A</b>	Circ A ECO EXV %	XXX (%)	0-100		forcible	QCK_TST1	Q_ECO_A	77
→ <b>ECO.B</b>	Circ B ECO EXV %	XXX (%)	0-100		forcible	QCK_TST1	Q_ECO_B	77
→ <b>ECO.C</b>	Circ C ECO EXV %	XXX (%)	0-100		forcible	QCK_TST1	Q_ECO_C	77
→ <b>FAN.A</b>	Circuit A Fan Stages	X	0-8		forcible	QCK_TST1	Q_FAN_A	
→ <b>FAN.B</b>	Circuit B Fan Stages	X	0-8		forcible	QCK_TST1	Q_FAN_B	
→ <b>FAN.C</b>	Circuit C Fan Stages	X	0-8		forcible	QCK_TST1	Q_FAN_C	
→ <b>SPD.A</b>	Cir A Varifan position	XXX (%)	0-100		forcible	QCK_TST1	Q_VFANA	
→ <b>SPD.B</b>	Cir B Varifan position	XXX (%)	0-100		forcible	QCK_TST1	Q_VFANB	
→ <b>SPD.C</b>	Cir C Varifan position	XXX (%)	0-100		forcible	QCK_TST1	Q_VFANC	
→ <b>HT.A</b>	Oil Heater Circuit A		OFF/ON		forcible	QCK_TST1	Q_HT_A	
→ <b>SL1.A</b>	Slide Valve 1 Cir A		OFF/ON		forcible	QCK_TST1	Q_SL1_A	
→ <b>SL2.A</b>	Slide Valve 2 Cir B		OFF/ON		forcible	QCK_TST1	Q_SL1_2A	
→ <b>HGP.A</b>	Hot Gas Bypass A Output		OFF/ON		forcible	QCK_TST1	Q_HGBP_A	
→ <b>OLS.A</b>	Oil Solenoid Cir A		OFF/ON		forcible	QCK_TST1	Q_OILS_A	
→ <b>DGT.A</b>	DGT Cool Solenoid A		OFF/ON		forcible	QCK_TST1	Q_CDGT_A	
→ <b>HT.B</b>	Oil Heater Circuit B		OFF/ON		forcible	QCK_TST1	Q_HT_B	
→ <b>SL1.B</b>	Slide Valve 1 Cir B		OFF/ON		forcible	QCK_TST1	Q_SL1_1B	
→ <b>SL2.B</b>	Slide Valve 2 Cir B		OFF/ON		forcible	QCK_TST1	Q_SL1_2B	
→ <b>HGP.B</b>	Hot Gas Bypass B Output		OFF/ON		forcible	QCK_TST1	Q_HGBP_B	
→ <b>OLS.B</b>	Oil Solenoid Cir A		OFF/ON		forcible	QCK_TST1	Q_OILS_B	
→ <b>DGT.B</b>	DGT Cool Solenoid B		OFF/ON		forcible	QCK_TST1	Q_CDGT_B	
→ <b>HT.C</b>	Oil Heater Circuit C		OFF/ON		forcible	QCK_TST1	Q_HT_C	
→ <b>SL1.C</b>	Slide Valve 1 Cir C		OFF/ON		forcible	QCK_TST1	Q_SL1_1C	
→ <b>SL2.C</b>	Slide Valve 2 Cir C		OFF/ON		forcible	QCK_TST1	Q_SL1_2C	
→ <b>HGP.C</b>	Hot Gas Bypass C Output		OFF/ON		forcible	QCK_TST1	Q_HGBP_C	
→ <b>OLS.C</b>	Oil Solenoid Cir C		OFF/ON		forcible	QCK_TST1	Q_OILS_C	
→ <b>DGT.C</b>	DGT Cool Solenoid C		OFF/ON		forcible	QCK_TST1	Q_CDGT_C	
→ <b>PMP.1</b>	Water Exchanger Pump 1		OFF/ON		forcible	QCK_TST1	Q_PMP1	
→ <b>PMP.2</b>	Water Exchanger Pump 2		OFF/ON		forcible	QCK_TST1	Q_PMP2	
→ <b>PMP.3</b>	Condenser Pump 1		OFF/ON		forcible	QCK_TST1	Q_HPMP1	
→ <b>CL.HT</b>	Cooler Heater Output		OFF/ON		forcible	QCK_TST1	Q_CL_HT	
→ <b>BVL.A</b>	Ball Valve Position A		OPEN/CLSE		forcible	QCK_TST1	Q_BVL_A	
→ <b>BVL.B</b>	Ball Valve Position B		OPEN/CLSE		forcible	QCK_TST1	Q_BVL_B	
→ <b>BVL.C</b>	Ball Valve Position C		OPEN/CLSE		forcible	QCK_TST1	Q_BVL_C	
→ <b>Q.RDY</b>	Chiller Ready Status		OFF/ON		forcible	QCK_TST1	Q_READY	
→ <b>Q.RUN</b>	Chiller Running Status		OFF/ON		forcible	QCK_TST1	Q_RUN	
→ <b>SHUT</b>	Customer Shutdown Stat		OFF/ON		forcible	QCK_TST1	Q_SHUT	
→ <b>CATO</b>	Chiller Capacity in 0-10v	XX.X (vdc)	0-10		forcible	QCK_TST1	Q_CATO	
→ <b>ALRM</b>	Alarm Relay		OFF/ON		forcible	QCK_TST1	Q_ALARM	
→ <b>ALRT</b>	Alert Relay		OFF/ON		forcible	QCK_TST1	Q_ALERT	



## APPENDIX B — NAVIGATOR™ DISPLAY TABLES (cont)

### MODE — TEMPERATURE

ITEM	EXPANSION	UNITS	RANGE	COMMENT	WRITE STATUS	CCN TABLE	CCN POINT	PAGE NO.
<b>UNIT</b>	UNIT TEMPERATURES							
→ <b>CEWT</b>	Cooler Entering Fluid	XXX.X (deg F/deg C)	-40-245 F (-40-118 C)			STATEGEN	COOL_EWT	
→ <b>CLWT</b>	Cooler Leaving Fluid	XXX.X (deg F/deg C)	-40-245 F (-40-118 C)			STATEGEN	COOL_LWT	
→ <b>CD.LT</b>	Condenser Entering Fluid	XXX.X (deg F/deg C)	-40-245 F (-40-118 C)	Not supported.			COND_LWT	
→ <b>CD.ET</b>	Condenser Leaving Fluid	XXX.X (deg F/deg C)	-40-245 F (-40-118 C)	Not supported.			COND_EWT	
→ <b>OAT</b>	Outside Air Temperature	XXX.X (deg F/deg C)	-40-245 F (-40-118 C)			GENUNIT	OAT	10,69
→ <b>CHWS</b>	Lead/Lag Leaving Fluid	XXX.X (deg F/deg C)	-40-245 F (-40-118 C)			STATEGEN	CHWS	10
→ <b>SPT</b>	Optional Space Temp	XXX.X (deg F/deg C)	-40-245 F (-40-118 C)			STATEGEN	SPACETMP	18
→ <b>THHR</b>	Cooler Heater Temp	XXX.X (deg F/deg C)	-40-245 F (-40-118 C)	Not supported.			TH_HEATER	
→ <b>THR.C</b>	Cooler Heat Temp Cir C	XXX.X (deg F/deg C)	-40-245 F (-40-118 C)	Not supported.			T_HEAT_C	
<b>CIR.A</b>	CIRCUIT A TEMPERATURES							
→ <b>SCT.A</b>	Sat Cond Temp Circ A	XXX.X (deg F/deg C)	-40-245 F (-40-118 C)			CIRCA_AN	SCT_A	
→ <b>SST.A</b>	Sat Suction Temp Circ A	XXX.X (deg F/deg C)	-40-245 F (-40-118 C)			CIRCA_AN	SST_A	96
→ <b>DGT.A</b>	Discharge Gas Temp Cir A	XXX.X (deg F/deg C)	-40-245 F (-40-118 C)			CIRCA_AN	DGT_A	12
→ <b>SGT.A</b>	Suction Gas Temp Circ A	XXX.X (deg F/deg C)	-40-245 F (-40-118 C)			CIRCA_AN	SUCT_T_A	14
→ <b>SUP.A</b>	Superheat Temp Circ A	XXX.X (ΔF/ΔC)				EXV_CTRL	SH_A	
→ <b>ECT.A</b>	Economizer Gas Temp A	XXX.X (deg F/deg C)	-40-245 F (-40-118 C)			CIRCA_AN	ECO_TP_A	14
→ <b>ESH.A</b>	Economizer Superheat A	XXX.X (deg F/deg C)	-40-245 F (-40-118 C)			EXV_CTRL	eco_sha	
→ <b>CTP.A</b>	Motor Temperature Cir A	XXX.X (deg F/deg C)	-40-245 F (-40-118 C)			CIRCA_AN	CP_TMP_A	12
<b>CIR.B</b>	CIRCUIT B TEMPERATURES							
→ <b>SCT.B</b>	Sat Cond Temp Circ B	XXX.X (deg F/deg C)	-40-245 F (-40-118 C)			CIRCB_AN	SCT_B	
→ <b>SST.B</b>	Sat Suction Temp Circ B	XXX.X (deg F/deg C)	-40-245 F (-40-118 C)			CIRCB_AN	SST_B	96
→ <b>DGT.B</b>	Discharge Gas Temp Cir B	XXX.X (deg F/deg C)	-40-245 F (-40-118 C)			CIRCB_AN	DGT_B	12
→ <b>SGT.B</b>	Suction Gas Temp Circ B	XXX.X (deg F/deg C)	-40-245 F (-40-118 C)			CIRCB_AN	SUCT_T_B	14
→ <b>SUP.B</b>	Superheat Temp Circ B	XXX.X (ΔF/ΔC)				EXV_CTRL	SH_B	
→ <b>ECT.B</b>	Economizer Gas Temp B	XXX.X (deg F/deg C)	-40-245 F (-40-118 C)			CIRCB_AN	ECO_TP_B	14
→ <b>ESH.B</b>	Economizer Superheat B	XXX.X (deg F/deg C)	-40-245 F (-40-118 C)			EXV_CTRL	eco_shb	
→ <b>CTP.B</b>	Motor Temperature Cir B	XXX.X (deg F/deg C)	-40-245 F (-40-118 C)			CIRCB_AN	CP_TMP_B	12
<b>CIR.C</b>	CIRCUIT C TEMPERATURES							
→ <b>SCT.C</b>	Sat Cond Temp Circ C	XXX.X (deg F/deg C)	-45-245 F (-43-118 C)			CIRCC_AN CIRCC_AN	SCT_C	
→ <b>SST.C</b>	Sat Suction Temp Circ C	XXX.X (deg F/deg C)	-45-245 F (-43-118 C)			CIRCC_AN	SST_C	96
→ <b>DGT.C</b>	Discharge Gas Temp Cir C	XXX.X (deg F/deg C)	-40-245 F (-40-118 C)			CIRCC_AN	DGT_C	12
→ <b>SGT.C</b>	Suction Gas Temp Circ C	XXX.X (deg F/deg C)	-45-245 F (-43-118 C)			CIRCC_AN	SUCT_T_C	14
→ <b>SUP.C</b>	Superheat Temp Circ C	XXX.X (ΔF/ΔC)				EXV_CTRL	SH_C	
→ <b>ECT.C</b>	Economizer Gas Temp C	XXX.X (deg F/deg C)	-45-245 F (-43-118 C)			CIRCC_AN	ECO_TP_C	14
→ <b>ESH.C</b>	Economizer Superheat C	XXX.X (deg F/deg C)	-40-245 F (-40-118 C)			EXV_CTRL	eco_shc	
→ <b>CTP.C</b>	Motor Temperature Cir C	XXX.X (deg F/deg C)	-45-245 F (-43-118 C)			CIRCC_AN	CP_TMP_C	12

## APPENDIX B — NAVIGATOR™ DISPLAY TABLES (cont)

### MODE — PRESSURE

ITEM	EXPANSION	UNITS	RANGE	COMMENT	WRITE STATUS	CCN TABLE	CCN POINT	PAGE NO.
<b>PRC.A</b>	CIRCUIT A PRESSURES							
→ <b>DP.A</b>	Discharge Pressure Cir A	XXX.X (psig/kPa)				CIRCA_AN	DP_A	10,70
→ <b>SP.A</b>	Suction Pressure Circ A	XXX.X (psig/kPa)				CIRCA_AN	SP_A	10
→ <b>OP.A</b>	Oil Pressure Circ A	XXX.X (psig/kPa)				CIRCA_AN	OP_A	12
→ <b>DOP.A</b>	Oil Pressure Diff A	XXX.X (psig/kPa)				CIRCA_AN	DOP_A	
→ <b>ECP.A</b>	Economizer Pressure A	XXX.X (psig/kPa)				CIRCA_AN	ECON_P_A	12
<b>PRC.B</b>	CIRCUIT B PRESSURES							
→ <b>DP.B</b>	Discharge Pressure Cir B	XXX.X (psig/kPa)				CIRCB_AN	DP_B	10,70
→ <b>SP.B</b>	Suction Pressure Circ B	XXX.X (psig/kPa)				CIRCB_AN	SP_B	10
→ <b>OP.B</b>	Oil Pressure Circ B	XXX.X (psig/kPa)				CIRCB_AN	OP_B	12
→ <b>DOP.B</b>	Oil Pressure Diff B	XXX.X (psig/kPa)				CIRCB_AN	DOP_B	
→ <b>ECP.B</b>	Economizer Pressure B	XXX.X (psig/kPa)				CIRCB_AN	ECON_P_B	12
<b>PRC.C</b>	CIRCUIT A PRESSURES							
→ <b>DP.C</b>	Discharge Pressure Cir C	XXX.X (psig/kPa)				CIRCC_AN	DP_C	17,70
→ <b>SP.C</b>	Suction Pressure Circ C	XXX.X (psig/kPa)				CIRCC_AN	SP_C	17
→ <b>OP.C</b>	Oil Pressure Circ C	XXX.X (psig/kPa)				CIRCC_AN	OP_C	12
→ <b>DOP.C</b>	Oil Pressure Diff C	XXX.X (psig/kPa)				CIRCC_AN	DOP_C	
→ <b>ECP.C</b>	Economizer Pressure C	XXX.X (psig/kPa)				CIRCC_AN	ECON_P_C	12

### MODE — INPUTS

ITEM	EXPANSION	UNITS	RANGE	COMMENT	WRITE STATUS	CCN TABLE	CCN POINT	PAGE NO.
<b>GEN.I</b>	GENERAL INPUTS							
→ <b>ONOF</b>	On Off Switch		OPEN/CLSE			STATEGEN	ONOF	10
→ <b>LOCK</b>	Cooler Interlock		OPEN/CLSE			STATEGEN	LOCK_1	10,48
→ <b>COND</b>	Condenser Flow Switch		OPEN/CLSE			STATEGEN	CONFLOW	
→ <b>DLS1</b>	Demand Limit Switch 1		OPEN/CLSE			STATEGEN	LIM_SW1	10
→ <b>DLS2</b>	Demand Limit Switch 2		OPEN/CLSE			STATEGEN	LIM_SW2	18
→ <b>ICE.D</b>	Ice Done		OFF/ON			STATEGEN	ICE_SW	18,29
→ <b>DUAL</b>	Dual Setpoint Switch		OFF/ON			STATEGEN	SETP_SW	10,29
→ <b>ELEC</b>	Electrical Box Safety		OPEN/CLSE			STATEGEN	ELEC_BOX	10
→ <b>PUMP</b>	Pump Run Feedback		OPEN/CLSE			STATEGEN	PUMP_DEF	10
→ <b>OCCS</b>	Occupancy Override Swit		OFF/ON			STATEGEN	OCC_OVSW	18
→ <b>HC.SW</b>	Heat Cool Switch Status		OFF/ON			STATEGEN	HC_SW	
→ <b>RLOC</b>	Remote Interlock Switch		OPEN/CLSE			STATEGEN	REM-LOCK	18
→ <b>OIL.A</b>	Oil Level Circuit A		LOW/HIGH			STATEGEN	OIL_L_A	
→ <b>OIL.B</b>	Oil Level Circuit B		LOW/HIGH			STATEGEN	OIL_L_B	
→ <b>OIL.C</b>	Oil Level Circuit C		LOW/HIGH			STATEGEN	OIL_L_C	
→ <b>CUR.A</b>	Motor Current Circuit A	XXX.X (amps)	0-600			STATEGEN	CURR_A	12
→ <b>CUR.B</b>	Motor Current Circuit B	XXX.X (amps)	0-600			STATEGEN	CURR_B	12
→ <b>CUR.C</b>	Motor Current Circuit C	XXX.X (amps)	0-600			STATEGEN	CURR_C	12
→ <b>DMND</b>	4-20 mA Demand Signal	XXX.X (mA)	4 to 20			STATEGEN	LIM_ANAL	18
→ <b>RSET</b>	4-20 mA Reset/Setpoint	XXX.X (mA)	4 to 20			STATEGEN	SP_RESET	18
→ <b>HT.SW</b>	Heater Switch Input	XXX.X (mA)	OFF/ON			STATEGEN	HEATR_SW	

## APPENDIX B — NAVIGATOR™ DISPLAY TABLES (cont)

### MODE — SET POINTS

ITEM	EXPANSION	UNITS	RANGE	COMMENT	WRITE STATUS	CCN TABLE	CCN POINT	PAGE NO.
<b>COOL</b> → <b>CSP.1</b>	COOLING SETPOINTS Cooling Setpoint 1	XXXX.X (deg F/deg C)	-20-70 F (-29-21 C), Default = 44.0		forcible	SETPOINT	csp1	27-29, 46,59
→ <b>CSP.2</b>	Cooling Setpoint 2	XXXX.X (deg F/deg C)	-20-70 F (-29-21 C), Default = 44.0		forcible	SETPOINT	csp2	27-29, 46,69
→ <b>CSP.3</b>	Ice Setpoint	XXXX.X (deg F/deg C)	-20-70 F (-29-21 C), Default = 44.0		forcible	SETPOINT	ice_sp	27,29, 46,69, 70
→ <b>CRV1</b>	Current No Reset Val	XX.X (mA)	0-20, Default = 0		forcible	SETPOINT	v_cr_no	40,42, 43
→ <b>CRV2</b>	Current Full Reset Val	XX.X (mA)	0-20, Default = 0		forcible	SETPOINT	v_cr_fu	40,42, 43
→ <b>CRT1</b>	Delta T No Reset Temp	XXX.X (ΔF/ΔC)	0-125 F (0-69.4 C), Default = 0		forcible	SETPOINT	dt_cr_no	38,40, 41
→ <b>CRT2</b>	Delta T Full Reset Temp	XXX.X (ΔF/ΔC)	0-125 F (0-69.4 C), Default = 0		forcible	SETPOINT	dt_cr_fu	38,40, 41
→ <b>CRO1</b>	OAT No Reset Temp	XXX.X (deg F/deg C)	0-125 F (-18-52 C), Default = 14.0		forcible	SETPOINT	oatcr_no	40,41
→ <b>CRO2</b>	OAT Full Reset Temp	XXX.X (deg F/deg C)	0-25 F (-18-52 C), Default = 14.0		forcible	SETPOINT	oatcr_fu	40,41
→ <b>CRS1</b>	Space T No Reset Temp	XXX.X (deg F/deg C)	0-125 F (-18-52 C), Default = 14.0		forcible	SETPOINT	spacr_no	40,42
→ <b>CRS2</b>	Space T Full Reset Temp	XXX.X (deg F/deg C)	0-125 F (-18-52 C), Default = 14.0		forcible	SETPOINT	spacr_fu	40,42
→ <b>DGRC</b>	Degrees Cool Reset	XX.X (ΔF/ΔC)	-30-30 F (-16.7-16.7 C), Default = 0		forcible	SETPOINT	cr_deg	38, 40- 43
→ <b>CAUT</b>	Cool Changeover Setpt	XX.X (deg F/deg C)	Default = 75.0	Not supported.	forcible	SETPOINT	cauto_sp	
→ <b>CRMP</b>	Cool Ramp Loading	X.X	0.2-2.0 ΔF (0.1-1.1 ΔC), Default = 1.0		forcible	SETPOINT	cramp_sp	38,48, 69
<b>HEAT</b> → <b>HSP.1</b>	HEATING SETPOINTS Heating Setpoint 1	XXX.X (deg F/deg C)	Default = 100	Not supported.	forcible	SETPOINT	HSP.1	
→ <b>HSP.2</b>	Heating Setpoint 2	XXX.X (deg F/deg C)	Default = 100	Not supported.	forcible	SETPOINT	HSP.2	
→ <b>HRV1</b>	Current to Reset Val	XX.X (mA)	Default = 0	Not supported.	forcible	SETPOINT	v_hr_no	
→ <b>HRV2</b>	Current Full Reset Val	XX.X (mA)	Default = 0	Not supported.	forcible	SETPOINT	v_hr_fu	
→ <b>HRT1</b>	Delta T No Reset Temp	XXX.X (ΔF/ΔC)	Default = 0	Not supported.	forcible	SETPOINT	dt_hr_no	
→ <b>HRT2</b>	Delta T Full Reset Temp	XXX.X (ΔF/ΔC)	Default = 0	Not supported.	forcible	SETPOINT	dt_hr_fu	
→ <b>HRO1</b>	OAT No Reset Temp	XXX.X (deg F/deg C)	Default = 14.0	Not supported.	forcible	SETPOINT	oathr_no	
→ <b>HRO2</b>	OAT Full Reset Temp	XXX.X (deg F/deg C)	Default = 14.0	Not supported.	forcible	SETPOINT	oathr_fu	
→ <b>DGRH</b>	Degrees Heat Reset	XX.X (ΔF/ΔC)	Default = 0	Not supported.	forcible	SETPOINT	DGRH	
→ <b>HAUT</b>	Heat Changeover Setpt	XX.X (deg F/deg C)	Default = 64	Not supported.	forcible	SETPOINT	haut_sp	
→ <b>HRMP</b>	Heat Ramp Loading	X.X	Default = 1.0	Not supported.	forcible	SETPOINT	hramp_sp	
<b>MISC</b> → <b>DLS1</b>	MISC SETPOINTS Switch Limit Setpoint 1	XXX (%)	0-100, Default = 100		forcible	SETPOINT	lim_sp1	43,44
→ <b>DLS2</b>	Switch Limit Setpoint 2	XXX (%)	0-100, Default = 100		forcible	SETPOINT	lim_sp2	18,43, 44
→ <b>DLS3</b>	Switch Limit Setpoint 3	XXX (%)	0-100, Default = 100		forcible	SETPOINT	lim_sp3	
→ <b>W.SCT</b>	Water Val Cond Stp	XXX.X (deg F/deg C)	80-140 F (26.7-60 C)	Not supported.		SETPOINT	w_sct_sp	

## APPENDIX B — NAVIGATOR™ DISPLAY TABLES (cont)

### MODE — OUTPUTS

ITEM	EXPANSION	UNITS	RANGE	COMMENT	WRITE STATUS	CCN TABLE	CCN POINT	PAGE NO.
<b>CIR.A</b>	<b>CIRCUIT A OUTPUTS</b>							
→ <b>CP.A</b>	Compressor A Relay		OFF/ON			CIRCA_D	CP_A	12
→ <b>HT.A</b>	Oil Heater Circuit A		OFF/ON			CIRCA_D	OIL_HT_A	10,12
→ <b>SL1.A</b>	Slide Valve 1 Cir A		OFF/ON			CIRCA_D	SLID1_A	12
→ <b>SL2.A</b>	Slide Valve 2 Cir A		OFF/ON			CIRCA_D	SLID2_A	12
→ <b>OLS.A</b>	Oil Solenoid Cir A		OFF/ON			CIRCA_D	OIL_SL_A	12
→ <b>HGB.A</b>	Hot Gas Bypass Cir A		OFF/ON			CIRCA_D		19
→ <b>FAN.A</b>	Circuit A Fan Stages	X	0-6			CIRCA_D	FAN_ST_A	
→ <b>SPD.A</b>	Circ A Varifan Position	XXX (%)	0-100			CIRCA_AN	hd_pos_a	16
→ <b>EXV.A</b>	Circuit A EXV % Open	XXX (%)	0-100			CIRCA_AN	EXV_A	14,76
→ <b>ECO.A</b>	Circ A EXV ECO % Open	XXX (%)	0-100			CIRCA_AN	EXV_EC_A	14
→ <b>DGT.A</b>	DGT Cool Solenoid A		OFF/ON			CIRCA_D	dgt_gascool_a	12
<b>CIR.B</b>	<b>CIRCUIT B OUTPUTS</b>							
→ <b>CP.B</b>	Compressor B Relay		OFF/ON			CIRCB_D	CP_B	12
→ <b>HT.B</b>	Oil Heater Circuit B		OFF/ON			CIRCB_D	OIL_HT_B	10,12
→ <b>SL1.B</b>	Slide Valve 1 Cir B		OFF/ON			CIRCB_D	SLID1_B	12
→ <b>SL2.B</b>	Slide Valve 2 Cir B		OFF/ON			CIRCB_D	SLID2_B	12
→ <b>OLS.B</b>	Oil Solenoid Cir B		OFF/ON			CIRCB_D	OIL_SL_B	12
→ <b>HGB.B</b>	Hot Gas Bypass Cir B		OFF/ON			CIRCB_D		19
→ <b>FAN.B</b>	Circuit B Fan Stages	X	0-6			CIRCB_D	FAN_ST_B	
→ <b>SPD.B</b>	Circ B Varifan Position	XXX (%)	0-100			CIRCB_AN	hd_pos_b	16
→ <b>EXV.B</b>	Circuit B EXV % Open	XXX (%)	0-100			CIRCB_AN	EXV_B	14,76
→ <b>ECO.B</b>	Circ B EXV ECO % Open	XXX (%)	0-100			CIRCB_AN	EXV_EC_B	14
→ <b>DGT.B</b>	DGT Cool Solenoid B		OFF/ON			CIRCB_D	dgt_gascool_b	12
<b>CIR.C</b>	<b>CIRCUIT C OUTPUTS</b>							
→ <b>CP.C</b>	Compressor C Relay	OFF/ON				CIRCC_D	CP_C	12
→ <b>HT.C</b>	Oil Heater Circuit C	OFF/ON				CIRCC_D	OIL_HT_C	12
→ <b>SL1.C</b>	Slide Valve 1 Cir C		OFF/ON			CIRCC_D	SLID1_C	12
→ <b>SL2.C</b>	Slide Valve 2 Cir C		OFF/ON			CIRCC_D	SLID2_C	12
→ <b>OLS.C</b>	Oil Solenoid Cir C		OFF/ON			CIRCC_D	OIL_SL_C	12
→ <b>HGB.C</b>	Hot Gas Bypass Cir C		OFF/ON			CIRCC_D		19
→ <b>FAN.C</b>	Circuit C Fan Stages	X	0-6			CIRCC_D	FAN_ST_C	
→ <b>SPD.C</b>	Circ C Varifan Position	XXX (%)	0-100			CIRCC_AN	hd_pos_c	16,17
→ <b>EXV.C</b>	Circuit C EXV % Open	XXX (%)	0-100			CIRCC_AN	EXV_C	14,76
→ <b>ECO.C</b>	Circ C EXV ECO % Open	XXX (%)	0-100			CIRCC_AN	EXV_EC_C	14
→ <b>DGT.C</b>	DGT Cool Solenoid C		OFF/ON			CIRCC_D	dgt_gascool_c	12
<b>GEN.O</b>	<b>GENERAL OUTPUTS</b>							
→ <b>PMP.1</b>	Water Exchanger Pump 1		OFF/ON		forcible	STATEGEN	CPUMP_1	19
→ <b>PMP.2</b>	Water Exchanger Pump 2		OFF/ON		forcible	STATEGEN	CPUMP_2	19
→ <b>PMP.3</b>	Condenser Pump 1		OFF/ON			STATEGEN	HPUMP_1	
→ <b>CO.HT</b>	Cooler Heater Output		OFF/ON			STATEGEN	COOLHEAT	10
→ <b>BVL.A</b>	Ball Valve Position A		OPEN/CLOSE			CIRCA_D	ref_iso_a	10
→ <b>BVL.B</b>	Ball Valve Position B		OPEN/CLOSE			CIRCB_D	ref_iso_b	10
→ <b>BVL.C</b>	Ball Valve Position C		OPEN/CLOSE			CIRCC_D	ref_iso_c	10
→ <b>CN.HT</b>	Condenser Heat Output		OFF/ON			RECLAIM	cond_htr	
→ <b>REDY</b>	Chiller Ready Status		OFF/ON	Not supported.		STATEGEN	READY	
→ <b>RUN</b>	Chiller Running Status		OFF/ON			STATEGEN	RUNNING	18
→ <b>SHUT</b>	Customer Shutdown Stat		OFF/ON			STATEGEN	SHUTDOWN	18
→ <b>CATO</b>	Chiller Capacity 0-10 v	XX.X	0-10			STATEGEN	CAPT_010	18
→ <b>ALRM</b>	Alarm Relay		OFF/ON			STATEGEN	ALARM	10
→ <b>ALRT</b>	Alert Relay		OFF/ON			STATEGEN	ALERT	10



## APPENDIX B — NAVIGATOR™ DISPLAY TABLES (cont)

### MODE — CONFIGURATION (cont)

ITEM	EXPANSION	UNITS	RANGE	COMMENT	DEFAULT	CCN TABLE	CCN POINT	PAGE NO.
<b>SERV</b> → <b>FLUD</b>	SERVICE CONFIGURATIONS Cooler Fluid Type		WATER BRINE		WATER	SERVICE1	flui_typ	28,30,48, 49,69,70, 97,98
→ <b>CFLU</b>	Condenser Fluid Type		WATER BRINE	Not supported.	WATER		cond_typ	
→ <b>MOP</b>	EXV MOP Setpoint	XX.X (deg F/deg C)	40-60 F (4.4-15.6 C)		62.0	SERVICE1	mop_sp	98
→ <b>HP.TH</b>	High Pressure Threshold	XXX.X (psi/kPa)	200-300 psi (1724-1930 kPa)		290	SERVICE1	hp_th	49,70
→ <b>SHP.A</b>	Cir A Superheat Setp	XX.X (ΔF/ΔC)	12.6-44.0 F (1.7-7.8 C)		14.4*	SERVICE1	sh_sp_a	98
→ <b>SHP.B</b>	Cir B Superheat Setp	XX.X (ΔF/ΔC)	12.6-44.0 F (1.7-7.8 C)		14.4*	SERVICE1	sh_sp_b	98
→ <b>SHP.C</b>	Cir C Superheat Setp	XX.X (ΔF/ΔC)	12.6-44.0 F (1.7-7.8 C)		14.4	SERVICE1	sh_sp_c	98
→ <b>HTR</b>	Cooler Heater DT Setp	XX.X (ΔF/ΔC)	0.5-9 F (0.3-5.0 C)		2.0	SERVICE1	heatersp	69,80,82
→ <b>EWTO</b>	Entering Water Control		NO/YES		NO	SERVICE1	ewt_opt	27,95
→ <b>AU.SM</b>	Auto Start When SM Lost		NO/YES		NO	SERVICE1	auto_sm	27,99
→ <b>LLWT</b>	Brine Minimum Fluid Temp	XX.X (deg F/deg C)	-20-38 F (-28.9-3.3 C)		38			
→ <b>LOSP</b>	Brine Freeze Setpoint	XX.X (deg F/deg C)	-20-50 F (-20-10 C)		34	SERVICE1	lowestsp	30,70,80, 82,97,98
→ <b>FL.SP</b>	Brine Flow Switch Setp		0-60	Not supported.	1	SERVICE1	flow_sp	
→ <b>HD.PG</b>	Varifan Proportion Gain	XX.X	-10-10		2.0	SERVICE1	hd_pg	
→ <b>HD.DG</b>	Varifan Derivative Gain	XX.X	-10-10		0.4	SERVICE1	hd_dg	
→ <b>HD.IG</b>	Varifan Integral Gain	XX.X	-10-10		0.2	SERVICE1	hd_ig	
→ <b>F.LOA</b>	Fast Load Select		0-4		0	SERVICE1	fastload	
→ <b>AVFA</b>	Fan A Drive Attach		NO/YES	Not supported.	NO			
→ <b>AVFB</b>	Fan B Drive Attach		NO/YES	Not supported.	NO			
→ <b>AVFC</b>	Fan C Drive Attach		NO/YES	Not supported.	NO			
→ <b>EWTS</b>	EWT Probe on Cir A Side		NO/YES		YES	SERVICE1	ewt_cirA	
→ <b>MAXL</b>	Max Condenser LWT 45DC		NO/YES	Not supported.	NO	FACTORY	max_clwt	
<b>OPTN</b>	OPTIONS CONFIGURATION							
→ <b>CCNA</b>	CCN Address	XXX	1-239		1	N/A	CCNA	
→ <b>CCNB</b>	CCN Bus Number	XXX	0-239		0	N/A	CCNB	
→ <b>BAUD</b>	CCN Baud Rate		2400 4800 9600 19200 38400		9600	N/A	BAUD	
→ <b>LOAD</b>	Loading Sequence Select		Equal Staged		EQUAL	USER	lead_cir	32
→ <b>LLCS</b>	Lead/Lag Circuit Select		Automatic Cir A Leads Cir B Leads Cir C Leads		AUTOMATIC	USER	seq_typ	31,32
→ <b>RL.S</b>	Ramp Load Select		ENBL/DSBL		DSBL	USER	ramp_sel	38,69
→ <b>DELY</b>	Minutes Off Time	XX (Minutes)	1 to 15†		1	USER	off_on_d	31,68
→ <b>ICE.M</b>	Ice Mode Enable		ENBL/DSBL		DSBL	USER	ice_cfg	29,46
→ <b>HPUM</b>	Condenser Pumps Sequence		No Pump 1 Pump Only 2 Pumps Auto PMP 1 Manual PMP 2 Manual	Not supported.	NO PUMP		hpum_seq	
→ <b>PUMP</b>	Cooler Pumps Sequence		No Pump 1 Pump Only 2 Pumps Auto PMP 1 Manual PMP 2 Manual		NO PUMP	USER	pump_seq	30,31,59, 70,97,102
→ <b>ROT.P</b>	Pump Rotation Delay	XXXX (hours)	24 to 3000		48	USER	pump_del	31,70
→ <b>PM.PS</b>	Periodic Pump Start		NO-YES		NO	USER	pump_per	30,31,70
→ <b>PSBY</b>	Stop Pump In Standby		NO-YES		NO	USER	pump_sby	
→ <b>P.LOC</b>	Flow Checked if Pmp Off		NO-YES		NO	USER	pump_loc	30,31,102
→ <b>LS.ST</b>	Night Low Noise Start	XX.XX	00.00-23.59		00.00	USER	nh_start	38,70
→ <b>LS.ND</b>	Night Low Noise End	XX.XX	00-00-23.59		00.00	USER	nh_end	38,70
→ <b>LS.LT</b>	Low Noise Capacity Lim	XXX (%)	0-100		100	USER	nh_limit	38,70
→ <b>RV.AL</b>	Reverse Alarms Relay		NO-YES		NO	USER	al_rever	20
→ <b>OA.TH</b>	Heat Mode OAT Threshold	XX.X (deg F/deg C)		Not supported.	5 F	USER	heat_th	
→ <b>CUR.S</b>	Current Limit Select		NO/YES		NO	USER	curr_sel	43,44
→ <b>CUR.F</b>	Current Limit at 100%	XXXX	0 to 5000		2000	USER	curr_ful	43,44

\* Superheat setpoint for DX cooler unit see table below:

SUPERHEAT SETPOINT FOR DX COOLER				
FLUID	CKT.	UNIT SIZE		
		082-242	262-302	327-352
Water LWT ≥ 40 F	A	15	10	10
	B	15	15	10
Brine LWT < 40 F	A	25	20	20
	B	25	25	20

†Do not configure to 0.

## APPENDIX B — NAVIGATOR™ DISPLAY TABLES (cont)

### MODE — CONFIGURATION (cont)

ITEM	EXPANSION	UNITS	RANGE	COMMENT	DEFAULT	CCN TABLE	CCN POINT	PAGE NO.
<b>RSET</b> → <b>CRST</b>	RESET, DEMAND LIMIT, MASTER/SLAVE Cooling Reset Type		No Reset Out Air Temp Delta T Temp 4-20 mA Input Space Temp		NO RESET	USER	cr_sel	38,40,42,69
→ <b>HRST</b>	Heating Reset Type		No Reset Out Air Temp Delta T Temp 4-20 mA Input Space Temp		NO RESET	USER	hr_sel	
→ <b>DMDC</b>	Demand Limit Select		None Switch 4-20 mA Input		NONE	USER	lim_sel	42,43,44,69
→ <b>DMMX</b>	mA for 100% Demand Limit	XX.X (mA)			0.0	USER	lim_mx	44,45
→ <b>DMZE</b>	mA for 0% Demand Limit	XX.X (mA)			10.0	USER	lim_ze	44,45
→ <b>MSSL</b>	Master/Slave Select		Disable Master Slave		DISABLE	MST_SLV	ms_sel	32,34- 37,70,95, 99,100
→ <b>SLVA</b>	Slave Address	XXX	1-236		2	MST_SLV	slv_addr	32,34-37
→ <b>LLBL</b>	Lead/Lag Balance Select		Always Lead Lag if Fail Runtime Sel		Always Lead	MST_SLV	ll_bal	32,34-37, 68
→ <b>LLBD</b>	Lead/Lag Balance Delta	XXX (hours)	40-400		168	MST_SLV	ll_bal_d	32,34-37,68
→ <b>LLDY</b>	Lead/Lag Delay	XX (minutes)	2-30		10	MST_SLV	lsrt_tim	32,34-37,68
→ <b>LLER</b>	Start if Error Higher	XX.X (deg F/deg C)	3-18		4	MST_SLV	start_dt	32,34-37
→ <b>LAG.M</b>	Lag Minimum Running Time	XXX (min)	0-150		0	MST_SLV	lag_mini	32,34-37
→ <b>LAGP</b>	Lag Unit Pump Select		OFF if U stp ON if U stp		OFF if U stp	MST_SLV	lag_pump	32,34-37,68
→ <b>LPUL</b>	Lead Pulldown Time	XX (minutes)	0-60		0	MST_SLV	lead_pul	34-37,67,68
→ <b>SERI</b>	Chillers in Series		NO/YES		NO	MST_SLV	ll_serie	32,34-37



**APPENDIX B — NAVIGATOR™ DISPLAY TABLES (cont)**

**MODE — TIMECLOCK**

ITEM	EXPANSION	UNITS	RANGE	COMMENT	WRITE STATUS	CCN TABLE	CCN POINT	PAGE NO.
<b>TIME</b> → <b>HH.MM</b>	TIME OF DAY Hour and Minute	XX.XX	00.00-23.59		forcible	N/A	HH.MM	7
<b>DATE</b> → <b>MNTH</b>	DAY, DATE Month		1=January 2=February 3=March 4=April 5=May 6=June 7=July 8=August 9=September 10=October 11=November 12=December		forcible	N/A	MNTH	7
→ <b>DOM</b> → <b>DAY</b>	Day of Month Day of Week	XX	1-31 1=Monday 2=Tuesday 3=Wednesday 4=Thursday 5=Friday 6=Saturday 7=Sunday		forcible forcible	N/A N/A	DOM DAY	7 7
→ <b>YEAR</b>	Year of Century	XX	00-99		forcible	N/A	YEAR	7
<b>SCH1</b>	SCHEDULE 1							26
→ <b>PER.1</b>	Period 1 Occ/Unocc Sel							
→ <b>PER.1</b> → <b>OCC.1</b>	Occupied Time	XX.XX	00:00-23:59		forcible	OCC1P01S	OCCTOD1	26
→ <b>PER.1</b> → <b>UNO.1</b>	Unoccupied Time	XX.XX	00:00-23:59		forcible	OCC1P01S	UNOCTOD1	26
→ <b>PER.1</b> → <b>MON.1</b>	Monday Select		NO/YES		forcible	OCC1P01S	DOW1	26
→ <b>PER.1</b> → <b>TUE.1</b>	Tuesday Select		NO/YES		forcible	OCC1P01S	DOW1	26
→ <b>PER.1</b> → <b>WED.1</b>	Wednesday Select		NO/YES		forcible	OCC1P01S	DOW1	26
→ <b>PER.1</b> → <b>THU.1</b>	Thursday Select		NO/YES		forcible	OCC1P01S	DOW1	26
→ <b>PER.1</b> → <b>FRI.1</b>	Friday Select		NO/YES		forcible	OCC1P01S	DOW1	26
→ <b>PER.1</b> → <b>SAT.1</b>	Saturday Select		NO/YES		forcible	OCC1P01S	DOW1	26
→ <b>PER.1</b> → <b>SUN.1</b>	Sunday Select		NO/YES		forcible	OCC1P01S	DOW1	26
→ <b>PER.1</b> → <b>HOL.1</b>	Holiday Select		NO/YES		forcible	OCC1P01S	DOW1	26
→ <b>PER.2</b>	Period 2 Occ/Unocc Sel							
→ <b>PER.2</b> → <b>OCC.2</b>	Occupied Time	XX.XX	00:00-23:59		forcible	OCC1P01S	OCCTOD2	26
→ <b>PER.2</b> → <b>UNO.2</b>	Unoccupied Time	XX.XX	00:00-23:59		forcible	OCC1P01S	UNOCTOD2	26
→ <b>PER.2</b> → <b>MON.2</b>	Monday Select		NO/YES		forcible	OCC1P01S	DOW2	26
→ <b>PER.2</b> → <b>TUE.2</b>	Tuesday Select		NO/YES		forcible	OCC1P01S	DOW2	26
→ <b>PER.2</b> → <b>WED.2</b>	Wednesday Select		NO/YES		forcible	OCC1P01S	DOW2	26
→ <b>PER.2</b> → <b>THU.2</b>	Thursday Select		NO/YES		forcible	OCC1P01S	DOW2	26
→ <b>PER.2</b> → <b>FRI.2</b>	Friday Select		NO/YES		forcible	OCC1P01S	DOW2	26
→ <b>PER.2</b> → <b>SAT.2</b>	Saturday Select		NO/YES		forcible	OCC1P01S	DOW2	26
→ <b>PER.2</b> → <b>SUN.2</b>	Sunday Select		NO/YES		forcible	OCC1P01S	DOW2	26
→ <b>PER.2</b> → <b>HOL.2</b>	Holiday Select		NO/YES		forcible	OCC1P01S	DOW2	26
→ <b>PER.3</b>	Period 3 Occ/Unocc Sel							
→ <b>PER.3</b> → <b>OCC.3</b>	Occupied Time	XX.XX	00:00-23:59		forcible	OCC1P01S	OCCTOD3	26
→ <b>PER.3</b> → <b>UNO.3</b>	Unoccupied Time	XX.XX	00:00-23:59		forcible	OCC1P01S	UNOCTOD3	26
→ <b>PER.3</b> → <b>MON.3</b>	Monday Select		NO/YES		forcible	OCC1P01S	DOW3	26
→ <b>PER.3</b> → <b>TUE.3</b>	Tuesday Select		NO/YES		forcible	OCC1P01S	DOW3	26
→ <b>PER.3</b> → <b>WED.3</b>	Wednesday Select		NO/YES		forcible	OCC1P01S	DOW3	26
→ <b>PER.3</b> → <b>THU.3</b>	Thursday Select		NO/YES		forcible	OCC1P01S	DOW3	26
→ <b>PER.3</b> → <b>FRI.3</b>	Friday Select		NO/YES		forcible	OCC1P01S	DOW3	26
→ <b>PER.3</b> → <b>SAT.3</b>	Saturday Select		NO/YES		forcible	OCC1P01S	DOW3	26
→ <b>PER.3</b> → <b>SUN.3</b>	Sunday Select		NO/YES		forcible	OCC1P01S	DOW3	26
→ <b>PER.3</b> → <b>HOL.3</b>	Holiday Select		NO/YES		forcible	OCC1P01S	DOW3	26
→ <b>PER.4</b>	Period 4 Occ/Unocc Sel							
→ <b>PER.4</b> → <b>OCC.4</b>	Occupied Time	XX.XX	00:00-23:59		forcible	OCC1P01S	OCCTOD4	26
→ <b>PER.4</b> → <b>UNO.4</b>	Unoccupied Time	XX.XX	00:00-23:59		forcible	OCC1P01S	UNOCTOD4	26
→ <b>PER.4</b> → <b>MON.4</b>	Monday Select		NO/YES		forcible	OCC1P01S	DOW4	26
→ <b>PER.4</b> → <b>TUE.4</b>	Tuesday Select		NO/YES		forcible	OCC1P01S	DOW4	26
→ <b>PER.4</b> → <b>WED.4</b>	Wednesday Select		NO/YES		forcible	OCC1P01S	DOW4	26
→ <b>PER.4</b> → <b>THU.4</b>	Thursday Select		NO/YES		forcible	OCC1P01S	DOW4	26
→ <b>PER.4</b> → <b>FRI.4</b>	Friday Select		NO/YES		forcible	OCC1P01S	DOW4	26
→ <b>PER.4</b> → <b>SAT.4</b>	Saturday Select		NO/YES		forcible	OCC1P01S	DOW4	26
→ <b>PER.4</b> → <b>SUN.4</b>	Sunday Select		NO/YES		forcible	OCC1P01S	DOW4	26
→ <b>PER.4</b> → <b>HOL.4</b>	Holiday Select		NO/YES		forcible	OCC1P01S	DOW4	26
→ <b>PER.5</b>	Period 5 Occ/Unocc Sel							
→ <b>PER.5</b> → <b>OCC.5</b>	Occupied Time	XX.XX	00:00-23:59		forcible	OCC1P01S	OCCTOD5	26
→ <b>PER.5</b> → <b>UNO.5</b>	Unoccupied Time	XX.XX	00:00-23:59		forcible	OCC1P01S	UNOCTOD5	26
→ <b>PER.5</b> → <b>MON.5</b>	Monday Select		NO/YES		forcible	OCC1P01S	DOW5	26
→ <b>PER.5</b> → <b>TUE.5</b>	Tuesday Select		NO/YES		forcible	OCC1P01S	DOW5	26
→ <b>PER.5</b> → <b>WED.5</b>	Wednesday Select		NO/YES		forcible	OCC1P01S	DOW5	26
→ <b>PER.5</b> → <b>THU.5</b>	Thursday Select		NO/YES		forcible	OCC1P01S	DOW5	26
→ <b>PER.5</b> → <b>FRI.5</b>	Friday Select		NO/YES		forcible	OCC1P01S	DOW5	26
→ <b>PER.5</b> → <b>SAT.5</b>	Saturday Select		NO/YES		forcible	OCC1P01S	DOW5	26
→ <b>PER.5</b> → <b>SUN.5</b>	Sunday Select		NO/YES		forcible	OCC1P01S	DOW5	26
→ <b>PER.5</b> → <b>HOL.5</b>	Holiday Select		NO/YES		forcible	OCC1P01S	DOW5	26
→ <b>PER.6</b>	Period 6 Occ/Unocc Sel							
→ <b>PER.6</b> → <b>OCC.6</b>	Occupied Time	XX.XX	00:00-23:59		forcible	OCC1P01S	OCCTOD6	26
→ <b>PER.6</b> → <b>UNO.6</b>	Unoccupied Time	XX.XX	00:00-23:59		forcible	OCC1P01S	UNOCTOD6	26
→ <b>PER.6</b> → <b>MON.6</b>	Monday Select		NO/YES		forcible	OCC1P01S	DOW6	26
→ <b>PER.6</b> → <b>TUE.6</b>	Tuesday Select		NO/YES		forcible	OCC1P01S	DOW6	26
→ <b>PER.6</b> → <b>WED.6</b>	Wednesday Select		NO/YES		forcible	OCC1P01S	DOW6	26
→ <b>PER.6</b> → <b>THU.6</b>	Thursday Select		NO/YES		forcible	OCC1P01S	DOW6	26
→ <b>PER.6</b> → <b>FRI.6</b>	Friday Select		NO/YES		forcible	OCC1P01S	DOW6	26
→ <b>PER.6</b> → <b>SAT.6</b>	Saturday Select		NO/YES		forcible	OCC1P01S	DOW6	26
→ <b>PER.6</b> → <b>SUN.6</b>	Sunday Select		NO/YES		forcible	OCC1P01S	DOW6	26
→ <b>PER.6</b> → <b>HOL.6</b>	Holiday Select		NO/YES		forcible	OCC1P01S	DOW6	26

**APPENDIX B — NAVIGATOR™ DISPLAY TABLES (cont)**

**MODE — TIMECLOCK (cont)**

ITEM	EXPANSION	UNITS	RANGE	COMMENT	WRITE STATUS	CCN TABLE	CCN POINT	PAGE NO.
<b>SCH1</b>	<b>SCHEDULE 1</b>							
→ PER.7	Period 7 Occ/Unocc Sel							
→ PER.7 → OCC.7	Occupied Time	XX.XX	00:00-23:59		forcible	OCCP01S	OCCTOD7	
→ PER.7 → UNO.7	Unoccupied Time	XX.XX	00:00-23:59		forcible	OCCP01S	UNOCTOD7	
→ PER.7 → MON.7	Monday Select		NO/YES		forcible	OCCP01S	DOW7	
→ PER.7 → TUE.7	Tuesday Select		NO/YES		forcible	OCCP01S	DOW7	
→ PER.7 → WED.7	Wednesday Select		NO/YES		forcible	OCCP01S	DOW7	
→ PER.7 → THU.7	Thursday Select		NO/YES		forcible	OCCP01S	DOW7	
→ PER.7 → FRI.7	Friday Select		NO/YES		forcible	OCCP01S	DOW7	
→ PER.7 → SAT.7	Saturday Select		NO/YES		forcible	OCCP01S	DOW7	
→ PER.7 → SUN.7	Sunday Select		NO/YES		forcible	OCCP01S	DOW7	
→ PER.7 → HOL.7	Holiday Select		NO/YES		forcible	OCCP01S	DOW7	
→ PER.8	Period 8 Occ/Unocc Sel							
→ PER.8 → OCC.8	Occupied Time	XX.XX	00:00-23:59		forcible	OCCP01S	OCCTOD8	
→ PER.8 → UNO.8	Unoccupied Time	XX.XX	00:00-23:59		forcible	OCCP01S	UNOCTOD8	
→ PER.8 → MON.8	Monday Select		NO/YES		forcible	OCCP01S	DOW8	
→ PER.8 → TUE.8	Tuesday Select		NO/YES		forcible	OCCP01S	DOW8	
→ PER.8 → WED.8	Wednesday Select		NO/YES		forcible	OCCP01S	DOW8	
→ PER.8 → THU.8	Thursday Select		NO/YES		forcible	OCCP01S	DOW8	
→ PER.8 → FRI.8	Friday Select		NO/YES		forcible	OCCP01S	DOW8	
→ PER.8 → SAT.8	Saturday Select		NO/YES		forcible	OCCP01S	DOW8	
→ PER.8 → SUN.8	Sunday Select		NO/YES		forcible	OCCP01S	DOW8	
→ PER.8 → HOL.8	Holiday Select		NO/YES		forcible	OCCP01S	DOW8	
<b>SCH2</b>	<b>SCHEDULE 2</b>							26
→ PER.1	Period 1 Occ/Unocc Sel							
→ PER.1 → OCC.1	Occupied Time	XX.XX	00:00-23:59		forcible	OCC2P02S	OCCTOD1	26
→ PER.1 → UNO.1	Unoccupied Time	XX.XX	00:00-23:59		forcible	OCC2P02S	UNOCTOD1	26
→ PER.1 → MON.1	Monday Select		NO/YES		forcible	OCC2P02S	DOW1	26
→ PER.1 → TUE.1	Tuesday Select		NO/YES		forcible	OCC2P02S	DOW1	26
→ PER.1 → WED.1	Wednesday Select		NO/YES		forcible	OCC2P02S	DOW1	26
→ PER.1 → THU.1	Thursday Select		NO/YES		forcible	OCC2P02S	DOW1	26
→ PER.1 → FRI.1	Friday Select		NO/YES		forcible	OCC2P02S	DOW1	26
→ PER.1 → SAT.1	Saturday Select		NO/YES		forcible	OCC2P02S	DOW1	26
→ PER.1 → SUN.1	Sunday Select		NO/YES		forcible	OCC2P02S	DOW1	26
→ PER.1 → HOL.1	Holiday Select		NO/YES		forcible	OCC2P02S	DOW1	26
→ PER.2	Period 2 Occ/Unocc Sel							
→ PER.2 → OCC.2	Occupied Time	XX.XX	00:00-23:59		forcible	OCC2P02S	OCCTOD	26
→ PER.2 → UNO.2	Unoccupied Time	XX.XX	00:00-23:59		forcible	OCC2P02S	UNOCTOD2	26
→ PER.2 → MON.2	Monday Select		NO/YES		forcible	OCC2P02S	DOW2	26
→ PER.2 → TUE.2	Tuesday Select		NO/YES		forcible	OCC2P02S	DOW2	26
→ PER.2 → WED.2	Wednesday Select		NO/YES		forcible	OCC2P02S	DOW2	26
→ PER.2 → THU.2	Thursday Select		NO/YES		forcible	OCC2P02S	DOW2	26
→ PER.2 → FRI.2	Friday Select		NO/YES		forcible	OCC2P02S	DOW2	26
→ PER.2 → SAT.2	Saturday Select		NO/YES		forcible	OCC2P02S	DOW2	26
→ PER.2 → SUN.2	Sunday Select		NO/YES		forcible	OCC2P02S	DOW2	26
→ PER.2 → HOL.2	Holiday Select		NO/YES		forcible	OCC2P02S	DOW2	26
→ PER.3	Period 3 Occ/Unocc Sel							
→ PER.3 → OCC.3	Occupied Time	XX.XX	00:00-23:59		forcible	OCC2P02S	OCCTOD	26
→ PER.3 → UNO.3	Unoccupied Time	XX.XX	00:00-23:59		forcible	OCC2P02S	UNOCTOD3	26
→ PER.3 → MON.3	Monday Select		NO/YES		forcible	OCC2P02S	DOW3	26
→ PER.3 → TUE.3	Tuesday Select		NO/YES		forcible	OCC2P02S	DOW3	26
→ PER.3 → WED.3	Wednesday Select		NO/YES		forcible	OCC2P02S	DOW3	26
→ PER.3 → THU.3	Thursday Select		NO/YES		forcible	OCC2P02S	DOW3	26
→ PER.3 → FRI.3	Friday Select		NO/YES		forcible	OCC2P02S	DOW3	26
→ PER.3 → SAT.3	Saturday Select		NO/YES		forcible	OCC2P02S	DOW3	26
→ PER.3 → SUN.3	Sunday Select		NO/YES		forcible	OCC2P02S	DOW3	26
→ PER.3 → HOL.3	Holiday Select		NO/YES		forcible	OCC2P02S	DOW3	26
→ PER.4	Period 4 Occ/Unocc Sel							
→ PER.4 → OCC.4	Occupied Time	XX.XX	00:00-23:59		forcible	OCC2P02S	OCCTOD4	26
→ PER.4 → UNO.4	Unoccupied Time	XX.XX	00:00-23:59		forcible	OCC2P02S	UNOCTOD4	26
→ PER.4 → MON.4	Monday Select		NO/YES		forcible	OCC2P02S	DOW4	26
→ PER.4 → TUE.4	Tuesday Select		NO/YES		forcible	OCC2P02S	DOW4	26
→ PER.4 → WED.4	Wednesday Select		NO/YES		forcible	OCC2P02S	DOW4	26
→ PER.4 → THU.4	Thursday Select		NO/YES		forcible	OCC2P02S	DOW4	26
→ PER.4 → FRI.4	Friday Select		NO/YES		forcible	OCC2P02S	DOW4	26
→ PER.4 → SAT.4	Saturday Select		NO/YES		forcible	OCC2P02S	DOW4	26
→ PER.4 → SUN.4	Sunday Select		NO/YES		forcible	OCC2P02S	DOW4	26
→ PER.4 → HOL.4	Holiday Select		NO/YES		forcible	OCC2P02S	DOW4	26
→ PER.5	Period 5 Occ/Unocc Sel							
→ PER.5 → OCC.5	Occupied Time	XX.XX	00:00-23:59		forcible	OCC2P02S	OCCTOD5	26
→ PER.5 → UNO.5	Unoccupied Time	XX.XX	00:00-23:59		forcible	OCC2P02S	UNOCTOD5	26
→ PER.5 → MON.5	Monday Select		NO/YES		forcible	OCC2P02S	DOW5	26
→ PER.5 → TUE.5	Tuesday Select		NO/YES		forcible	OCC2P02S	DOW5	26
→ PER.5 → WED.5	Wednesday Select		NO/YES		forcible	OCC2P02S	DOW5	26
→ PER.5 → THU.5	Thursday Select		NO/YES		forcible	OCC2P02S	DOW5	26
→ PER.5 → FRI.5	Friday Select		NO/YES		forcible	OCC2P02S	DOW5	26
→ PER.5 → SAT.5	Saturday Select		NO/YES		forcible	OCC2P02S	DOW5	26
→ PER.5 → SUN.5	Sunday Select		NO/YES		forcible	OCC2P02S	DOW5	26
→ PER.5 → HOL.5	Holiday Select		NO/YES		forcible	OCC2P02S	DOW5	26
→ PER.6	Period 6 Occ/Unocc Sel							
→ PER.6 → OCC.6	Occupied Time	XX.XX	00:00-23:59		forcible	OCC2P02S	OCCTOD6	
→ PER.6 → UNO.6	Unoccupied Time	XX.XX	00:00-23:59		forcible	OCC2P02S	UNOCTOD6	
→ PER.6 → MON.6	Monday Select		NO/YES		forcible	OCC2P02S	DOW6	
→ PER.6 → TUE.6	Tuesday Select		NO/YES		forcible	OCC2P02S	DOW6	
→ PER.6 → WED.6	Wednesday Select		NO/YES		forcible	OCC2P02S	DOW6	
→ PER.6 → THU.6	Thursday Select		NO/YES		forcible	OCC2P02S	DOW6	
→ PER.6 → FRI.6	Friday Select		NO/YES		forcible	OCC2P02S	DOW6	
→ PER.6 → SAT.6	Saturday Select		NO/YES		forcible	OCC2P02S	DOW6	
→ PER.6 → SUN.6	Sunday Select		NO/YES		forcible	OCC2P02S	DOW6	
→ PER.6 → HOL.6	Holiday Select		NO/YES		forcible	OCC2P02S	DOW6	

**APPENDIX B — NAVIGATOR™ DISPLAY TABLES (cont)**

**MODE — TIMECLOCK (cont)**

ITEM	EXPANSION	UNITS	RANGE	COMMENT	WRITE STATUS	CCN TABLE	CCN POINT	PAGE NO.
→ PER.7	Period 7 Occ/Unocc Sel							
→ PER.7→ OCC.7	Occupied Time	XX.XX	00:00-23:59		forcible	OCC2P02S	OCCTOD7	
→ PER.7→ UNO.7	Unoccupied Time	XX.XX	00:00-23:59		forcible	OCC2P02S	UNOCTOD7	
→ PER.7→ MON.7	Monday Select		NO/YES		forcible	OCC2P02S	DOW7	
→ PER.7→ TUE.7	Tuesday Select		NO/YES		forcible	OCC2P02S	DOW7	
→ PER.7→ WED.7	Wednesday Select		NO/YES		forcible	OCC2P02S	DOW7	
→ PER.7→ THU.7	Thursday Select		NO/YES		forcible	OCC2P02S	DOW7	
→ PER.7→ FRI.7	Friday Select		NO/YES		forcible	OCC2P02S	DOW7	
→ PER.7→ SAT.7	Saturday Select		NO/YES		forcible	OCC2P02S	DOW7	
→ PER.7→ SUN.7	Sunday Select		NO/YES		forcible	OCC2P02S	DOW7	
→ PER.7→ HOL.7	Holiday Select		NO/YES		forcible	OCC2P02S	DOW7	
→ PER.8	Period 8 Occ/Unocc Sel							
→ PER.8→ OCC.8	Occupied Time	XX.XX	00:00-23:59		forcible	OCC2P02S	OCCTOD8	
→ PER.8→ UNO.8	Unoccupied Time	XX.XX	00:00-23:59		forcible	OCC2P02S	UNOCTOD8	
→ PER.8→ MON.8	Monday Select		NO/YES		forcible	OCC2P02S	DOW8	
→ PER.8→ TUE.8	Tuesday Select		NO/YES		forcible	OCC2P02S	DOW8	
→ PER.8→ WED.8	Wednesday Select		NO/YES		forcible	OCC2P02S	DOW8	
→ PER.8→ THU.8	Thursday Select		NO/YES		forcible	OCC2P02S	DOW8	
→ PER.8→ FRI.8	Friday Select		NO/YES		forcible	OCC2P02S	DOW8	
→ PER.8→ SAT.8	Saturday Select		NO/YES		forcible	OCC2P02S	DOW8	
→ PER.8→ SUN.8	Sunday Select		NO/YES		forcible	OCC2P02S	DOW8	
→ PER.8→ HOL.8	Holiday Select		NO/YES		forcible	OCC2P02S	DOW8	
<b>HOLI</b>	<b>HOLIDAYS*</b>							
→ HOL.1	Holiday 1 Configuration							
→ HOL.1→ MON.1	Holiday Start Month		1=January 2=February 3=March 4=April 5=May 6=June 7=July 8=August 9=September 10=October 11=November 12=December		forcible	HOLDY_01	HOL_MON	26
→ HOL.1→ DAY.1	Holiday Start Day	XX	1 to 31		forcible	HOLDY_01	HOL_DAY	26
→ HOL.1→ DUR.1	Holiday Duration in Days	XX	1 to 99		forcible	HOLDY_01	HOL_LEN	26
→ HOL.1→ HOL.2	Holiday 2 Configuration							
→ HOL.1→ MON.2	Holiday Start Month		See HOL.1→ MON.1		forcible	HOLDY_02	HOL_MON	26
→ HOL.2→ DAY.2	Holiday Start Day		See HOL.1→ DAY.1		forcible	HOLDY_02	HOL_DAY	26
→ HOL.2→ DUR.2	Holiday Duration in Days		See HOL.1→ DUR.1		forcible	HOLDY_02	HOL_LEN	26
→ HOL.16→ HO.16	Holiday 16 Configuration							
→ HOL.16→ MO.16	Holiday Start Month		See HOL.1→ MON.1		forcible	HOLDY_16		
→ HOL.16→ DA.16	Holiday Start Day		See HOL.1→ DAY.1		forcible	HOLDY_16		
→ HOL.16→ DU.16	Holiday Duration in Days		See HOL.1→ DUR.1		forcible	HOLDY_16		
<b>MCFG</b>	<b>SERVICE MAINTENANCE CONFIGURATION</b>							102
→ AL.SV	Service Warning Select		NO/YES	DEFAULT=NO	forcible	MAINTCFG	s_alert	
→ CHR.G	Refrigerant Charge		NO/YES	DEFAULT=NO	forcible	MAINTCFG	charge_a	
→ WATE	Water Loop Size		NO/YES	DEFAULT=NO	forcible	MAINTCFG	wloop_c	
→ PMP.1	Pump 1 (days)	XXXX (days)	0-65,500	DEFAULT=0	forcible	MAINTCFG	pump1_c	
→ PMP.2	Pump 2 (days)	XXXX (days)	0-65,500	DEFAULT=0	forcible	MAINTCFG	pump2_c	
→ PMP.3	Cond Pump 1 (days)	XXXX (days)	0-65,500	DEFAULT=0	forcible	MAINTCFG	hpump1_c	19
→ PMP.4	Cond Pump 2 (days)	XXXX (days)	0-65,500	DEFAULT=0	forcible	MAINTCFG	hpump2_c	19
→ W.FIL	Water Filter (days)	XXXX (days)	0-65,500	DEFAULT=0	forcible	MAINTCFG	wfilte_c	59
→ A.FIL	Comp A Oil Filter (days)	XXXX (days)	0-65,500	DEFAULT=0	forcible	MAINTCFG	ofilta_c	
→ B.FIL	Comp B Oil Filter (days)	XXXX (days)	0-65,500	DEFAULT=0	forcible	MAINTCFG	ofiltb_c	
→ C.FIL	Comp C Oil Filter (days)	XXXX (days)	0-65,500	DEFAULT=0	forcible	MAINTCFG	ofiltc_c	
→ RS.SV	Servicing Alert Reset		0=Default 1=Refrigerant Charge 2=Water loop size 3=Not used 4=Pump 1 5=Pump 2 6=Reclaim Pump (not used) 7=Reclaim Pump (not used) 8=Water Filter 9=Compressor A Oil Filter 10=Compressor B Oil Filter 11=Compressor C Oil Filter 12=Reset All	DEFAULT=0	forcible	SERMAINT	s_reset	

\*Holidays range from 1-16. Item has same structure, with the only difference being the two-number identifier.

## APPENDIX B — NAVIGATOR™ DISPLAY TABLES (cont)

### MODE — OPERATING MODE

ITEM	EXPANSION*	UNITS	RANGE	COMMENT	WRITE STATUS	CCN TABLE	CCN POINT	PAGE NO.
<b>SLCT</b> → <b>OPER</b>	OPERATING CONTROL TYPE Operating Control Type		Switch Ctrl Time Sched CCN Control Setpoint Occ	Default = Switch Ctrl	forcible	N/A	N/A	25-27, 34-37 46
→ <b>SP.SE</b>	Setpoint Select		Setpoint1 Setpoint2 4-20mA Setp Dual Setp Sw	Default = Setpoint Occ	forcible	GENUNIT	sp_ctrl	27-29
→ <b>HC.SE</b>	Heat Cool Select		Cooling Heating Auto Chgover Heat Cool Sw	Default = Cooling	forcible	GENUNIT	HC_SEL	27,29
<b>MODE*</b> → <b>MD01</b> → <b>MD02</b> → <b>MD03</b> → <b>MD04</b> → <b>MD05</b> → <b>MD06</b>	OPERATING MODES First Active Mode Second Active Mode Third Active Mode Fourth Active Mode Fifth Active Mode Sixth Active Mode		0-32 0-32 0-32 0-32 0-32 0-32			MODES MODES MODES MODES MODES MODES		68 68 68 68 68 68

\*Up to six current operating modes will be displayed.

NOTE: See Operating Modes starting on page 68.

### MODE — ALARMS

ITEM	EXPANSION*	UNITS	RANGE	COMMENT	WRITE STATUS	CCN TABLE	CCN POINT	PAGE NO.
<b>R.ALM</b>	RESET ALL CURRENT ALARM		NO/YES		forcible	N/A	N/A	
<b>ALRM†</b>	CURRENTLY ACTIVE ALARMS Current Alarm 1 Current Alarm 2 Current Alarm 3 Current Alarm 4 Current Alarm 5					GENUNIT GENUNIT GENUNIT GENUNIT GENUNIT	alarm_1 alarm_2 alarm_3 alarm_4 alarm_5	88
<b>H.ALM**</b>	ALARM HISTORY Alarm History #1 Alarm History #2 Alarm History #49 Alarm History #50					ALRMHIST ALRMHIST ALRMHIST ALRMHIST	alm_history_01 alm_history_02 alm_history_49 alm_history_50	

\*Expanded display will be actual alarm description.

†History of up to five past alarms will be displayed.

\*\*History of fifty past alarms will be displayed.

**APPENDIX C — CCN TABLES**  
**STATUS DISPLAY TABLES**

TABLE	DISPLAY NAME	RANGE	UNITS	POINT NAME	WRITE STATUS	
CIRCA_AN	CIRCUIT A ANALOG VALUES					
	Percent Total Capacity	0 - 100	%	CAPA_T		
	Discharge Pressure	nnn.n	psi	DP_A		
	Suction Pressure	nnn.n	psi	SP_A		
	Economizer Pressure	nnn.n	psi	ECON_P_A		
	Oil Pressure	nnn.n	psi	OP_A		
	Oil Pressure Difference	nnn.n	psi	DOP_A		
	Motor Current	nnn.n	AMPS	CURREN_A		
	Motor Temperature	nnnn	°F	CP_TMP_A		
	Discharge Gas Temp	nnnn	°F	DGT_A		
	Economizer Gas Temp	nnnn	°F	ECO_TP_A		
	Saturated Condensing Tmp	±nnn.n	°F	SCT_A		
	Saturated Suction Temp	±nnn.n	°F	SST_A		
	Compressor Suction Temp	±nnn.n	°F	SUCT_T_A		
	EXV Position	0 - 100	%	EXV_A		
Head Press Actuator Pos	0 - 100	%	hd_pos_a			
CIRCA_D	CIRCUIT A DISCRETE					
	Compressor Output	ON/OFF		COMP_A		
	Slide Valve 1 Output	ON/OFF		SLID_1_A		
	Slide Valve 2 Output	ON/OFF		SLID_2_A		
	Oil Heater Output	ON/OFF		OIL_HT_A		
	Oil Solenoid Output	ON/OFF		OIL_SL_A		
	Oil Level Input	Low/High		OIL_L_A		
	DGT Cooling Solenoid	ON/OFF		GASCOOLA		
	Hot Gas Bypass Output	ON/OFF		HGBP_A		
	FANS OUTPUT					
	Fan Output DO # 1	ON/OFF		fan_a1		
	Fan Output DO # 2	ON/OFF		fan_a2		
	Fan Output DO # 3	ON/OFF		fan_a3		
	Fan Output DO # 4	ON/OFF		fan_a4		
	Fan Output DO # 5	ON/OFF		fan_a5		
	Fan Output DO # 6	ON/OFF		fan_a6		
	Fan Output DO # 7	ON/OFF		fan_a7		
	Fan Output DO # 8	ON/OFF		fan_a8		
	Fan Staging Number	0-10		FAN_ST_A		
	MISCELLANEOUS					
	Ball Valve Position*	OPEN/CLSE		ISO_REFA		
	Ball Valve Closing Out*	ON/OFF		ISO_CL_A		
	Ball Valve Opening Out*	ON/OFF		ISO_OP_A		
	4 Way Refrigerant Valve†	ON/OFF		RV_A		
	CIRCB_AN	CIRCUIT B ANALOG VALUES				
		Percent Total Capacity	0 - 100	%	CAPB_T	
		Discharge Pressure	nnn.n	psi	DP_B	
		Suction Pressure	nnn.n	psi	SP_B	
		Economizer Pressure	nnn.n	psi	ECON_P_B	
		Oil Pressure	nnn.n	psi	OP_B	
		Oil Pressure Difference	nnn.n	psi	DOP_B	
		Motor Current	nnn.n	AMPS	CURREN_B	
		Motor Temperature	nnnn	°F	CP_TMP_B	
Discharge Gas Temp		nnnn	°F	DGT_B		
Economizer Gas Temp		nnnn	°F	ECO_TP_B		
Saturated Condensing Tmp		±nnn.n	°F	SCT_B		
Saturated Suction Temp		±nnn.n	°F	SST_B		
Compressor Suction Temp		±nnn.n	°F	SUCT_T_B		
EXV Position		0-100	%	EXV_B		
Head Press Actuator Pos	0-100	%	hd_pos_b			
CIRCB_D	CIRCUIT B DISCRETE					
	Compressor Output	ON/OFF		COMP_B		
	Slide Valve 1 Output	ON/OFF		SLID_1_B		
	Slide Valve 2 Output	ON/OFF		SLID_2_B		
	Oil Heater Output	ON/OFF		OIL_HT_B		
	Oil Solenoid Output	ON/OFF		OIL_SL_B		
	Oil Level Input	Low/High		OIL_L_B		
	DGT Cooling Solenoid	ON/OFF		GASCOOLB		
	Hot Gas Bypass Output	ON/OFF		HGBP_B		
	FANS OUTPUT					
	Fan Output DO # 1	ON/OFF		fan_b1		
	Fan Output DO # 2	ON/OFF		fan_b2		
	Fan Output DO # 3	ON/OFF		fan_b3		
	Fan Output DO # 4	ON/OFF		fan_b4		
	Fan Output DO # 5	ON/OFF		fan_b5		
	Fan Output DO # 6	ON/OFF		fan_b6		
	Fan Output DO # 7	ON/OFF		fan_b7		
	Fan Output DO # 8	ON/OFF		fan_b8		
	Fan Staging Number	0-10		FAN_ST_B		
	MISCELLANEOUS					
	Ball Valve Position	OPEN/CLSE		ISO_REFB		
	Ball Valve Closing Out	ON/OFF		ISO_CL_B		
	Ball Valve Opening Out	ON/OFF		ISO_OP_B		
	4 Way Refrigerant Valve†	ON/OFF		RV_B		

\*Not supported for units with DX cooler.

†Not supported.

## APPENDIX C — CCN TABLES (cont)

### STATUS DISPLAY TABLES (cont)

TABLE	DISPLAY NAME	RANGE	UNITS	POINT NAME	WRITE STATUS	
CIRCC_AN	CIRCUIT C ANALOG VALUES					
	Percent Total Capacity	0-100	%	CAPC_T		
	Discharge Pressure	nnn.n	psi	DP_C		
	Suction Pressure	nnn.n	psi	SP_C		
	Economizer Pressure	nnn.n	psi	ECON_P_C		
	Oil Pressure	nnn.n	psi	OP_C		
	Oil Pressure Difference	nnn.n	psi	DOP_C		
	Motor Current	nnn.n	AMPS	CURREN_C		
	Motor Temperature	nnnn	°F	CP_TMP_C		
	Discharge Gas Temp	nnnn	°F	DGT_C		
	Economizer Gas Temp	nnnn	°F	ECO_TP_C		
	Saturated Condensing Tmp	±nnn.n	°F	SCT_C		
	Saturated Suction Temp	±nnn.n	°F	SST_C		
	Compressor Suction Temp	±nnn.n	°F	SUCT_T_C		
EXV Position	0-100	%	EXV_C			
Head Press Actuator Pos	0-100	%	hd_pos_c			
CIRCC_D	CIRCUIT C DISCRETE					
	Compressor Output	ON/OFF		COMP_C		
	Slide Valve 1 Output	ON/OFF		SLID_1_C		
	Slide Valve 2 Output	ON/OFF		SLID_2_C		
	Oil Heater Output	ON/OFF		OIL_HT_C		
	Oil Solenoid Output	ON/OFF		OIL_SL_C		
	Oil Level Input	Low/High		OIL_L_C		
	DGT Cooling Solenoid	ON/OFF		GASCOOLC		
	Hot Gas Bypass Output	ON/OFF		HGBP_C		
	FANS OUTPUT					
	Fan Output DO # 1	ON/OFF		fan_c1		
	Fan Output DO # 2	ON/OFF		fan_c2		
	Fan Output DO # 3	ON/OFF		fan_c3		
	Fan Output DO # 4	ON/OFF		fan_c4		
	Fan Output DO # 5	ON/OFF		fan_c5		
	Fan Output DO # 6	ON/OFF		fan_c6		
	Fan Output DO # 7	ON/OFF		fan_c7		
	Fan Output DO # 8	ON/OFF		fan_c8		
	Fan Staging Number	0-10		FAN_ST_C		
	MISCELLANEOUS					
	Ball Valve Position	OPEN/CLSE		ISO_REFC		
	Ball Valve Closing Out	ON/OFF		ISO_CL_C		
	Ball Valve Opening Out	ON/OFF		ISO_OP_C		
	FAN HOURS	Free Cool A Pump Hours	nnnnn	hours	hr_fem_a	
		Free Cool B Pump Hours	nnnnn	hours	hr_fem_b	
		Circuit A Defrost Number	nnnnn	—	ub_def_a	
Circuit B Defrost Number		nnnnn	—	ub_def_b		
Circuit A Fan #1 Hours		nnnnn	hours	hr_fana1		
Circuit A Fan #2 Hours		nnnnn	hours	hr_fana2		
Circuit A Fan #3 Hours		nnnnn	hours	hr_fana3		
Circuit A Fan #4 Hours		nnnnn	hours	hr_fana4		
Circuit A Fan #5 Hours		nnnnn	hours	hr_fana5		
Circuit A Fan #6 Hours		nnnnn	hours	hr_fana6		
Circuit A Fan #7 Hours		nnnnn	hours	hr_fana7		
Circuit A Fan #8 Hours		nnnnn	hours	hr_fana8		
Circuit A Fan #9 Hours		nnnnn	hours	hr_fana9		
Circuit A Fan #10 Hours		nnnnn	hours	hrfana10		
Circuit B Fan #1 Hours		nnnnn	hours	hr_fanb1		
Circuit B Fan #2 Hours		nnnnn	hours	hr_fanb2		
Circuit B Fan #3 Hours		nnnnn	hours	hr_fanb3		
Circuit B Fan #4 Hours		nnnnn	hours	hr_fanb4		
Circuit B Fan #5 Hours		nnnnn	hours	hr_fanb5		
Circuit B Fan #6 Hours		nnnnn	hours	hr_fanb6		
Circuit B Fan #7 Hours		nnnnn	hours	hr_fanb7		
Circuit B Fan #8 Hours		nnnnn	hours	hr_fanb8		
Circuit B Fan #9 Hours		nnnnn	hours	hr_fanb9		
Circuit B Fan #10 Hours		nnnnn	hours	hrfanb10		
Circuit C Fan #1 Hours		nnnnn	hours	hr_fanc1		
Circuit C Fan #2 Hours		nnnnn	hours	hr_fanc2		
Circuit C Fan #3 Hours		nnnnn	hours	hr_fanc3		
Circuit C Fan #4 Hours		nnnnn	hours	hr_fanc4		
Circuit C Fan #5 Hours		nnnnn	hours	hr_fanc5		
Circuit C Fan #6 Hours		nnnnn	hours	hr_fanc6		
Circuit C Fan #7 Hours		nnnnn	hours	hr_fanc7		
Circuit C Fan #8 Hours		nnnnn	hours	hr_fanc8		

## APPENDIX C — CCN TABLES (cont)

### STATUS DISPLAY TABLES (cont)

TABLE	DISPLAY NAME	RANGE	UNITS	POINT NAME	WRITE STATUS	
GENUNIT	Operating Type Control Type	L-Off-Local Off (Navigator Display= SW1 Switch=Opened) L-On-Local On L-Sched-Local On/Off State based on Time Schedules CCN-Unit is in CCN Control Remote-On/Off Based on Remote Contact (not applied to Navigator Display) Master-Unit Operation in Lead/Lag and it is a Master		OPER_TYP		
	Run Status	Local CCN Remote 0 = Off 1 = Running 2 = Stopping 3 = Delay 4 = Tripout 5 = Ready 6 = Override 7 = Defrost 8 = Run Test 9 = Test		ctr_type  STATUS		
	CCN Chiller Start/Stop Chiller Occupied? Minutes Left for Start Heat/Cool Status	Enable/Disable Yes/No 0-15 0 = Cool 1 = Heat 2 = Stand-by 3 = Both	min	CHIL_S_S CHIL_OCC min_left HEATCOOL	forcible forcible	
	Heat/Cool Select	0 = Cool 1 = Heat 2 = Auto		HC_SEL	forcible	
	Heat Reclaim Select Free Cooling Selct Alarm State	Yes/No Yes/No 0 = Normal 1 = Partial 2 = Shutdown		RECL_SEL FC_DSBLE ALM	forcible* forcible	
	Current Alarm 1 Current Alarm 2 Current Alarm 3 Current Alarm 4 Current Alarm 5	nnnnn nnnnn nnnnn nnnnn nnnnn		alarm_1 alarm_2 alarm_3 alarm_4 alarm_5		
	Percent Total Capacity Active Demand Limit Val Lag Capacity Limit Value	nnn nnn nnn	% % %	CAP_T DEM_LIM LAG_LIM	forcible†	
	Actual Chiller Current Chiller Current Limit Current Setpoint Setpoint Occupied? Setpoint Control	nnn nnn ±nnn.n Yes/No Setpt 1 Setpt 2 Ice_sp 4-20mA Auto	amps amps °F	TOT_CURR CURR_LIM SP SP_OCC sp_ctrl	forcible† forcible forcible	
	Control Point Controlled Water Temp External Temperature Emergency Stop	±nnn.n ±nnn.n ±nnn.n Enable/Disable	°F °F °F	CTRL_PNT CTRL_WT OAT EMSTOP	forcible† forcible	
	MODES	Startup Delay in Effect	Yes/No	—	Mode_01	
		Second Setpoint in Use	Yes/No	—	Mode_02	
		Reset in Effect	Yes/No	—	Mode_03	
		Demand Limit Active	Yes/No	—	Mode_04	
		Ramp Loading Active	Yes/No	—	Mode_05	
		Cooler Heater Active	Yes/No	—	Mode_06	
		Cooler Pumps Rotation	Yes/No	—	Mode_07	
		Pump Periodic Start	Yes/No	—	Mode_08	
		Night Low Noise Active	Yes/No	—	Mode_09	
		System Manager Active	Yes/No	—	Mode_10	
		Master Slave Active	Yes/No	—	Mode_11	
		Auto Changeover Active	Yes/No	—	Mode_12	
		Free Cooling Active	Yes/No	—	Mode_13	
		Reclaim Active	Yes/No	—	Mode_14	
		Electric Heat Active	Yes/No	—	Mode_15	
		Heating Low EWT Lockout	Yes/No	—	Mode_16	
		Condenser Pumps Rotation	Yes/No	—	Mode_17	
		Ice Mode in Effect	Yes/No	—	Mode_18	
		Defrost Active On Cir A	Yes/No	—	Mode_19	
		Defrost Active On Cir B	Yes/No	—	Mode_20	
		Low Suction Circuit A	Yes/No	—	Mode_21	
		Low Suction Circuit B	Yes/No	—	Mode_22	
		Low Suction Circuit C	Yes/No	—	Mode_23	
High DGT Circuit A		Yes/No	—	Mode_24		
High DGT Circuit B		Yes/No	—	Mode_25		
High DGT Circuit C		Yes/No	—	Mode_26		
High Pres Override Cir A		Yes/No	—	Mode_27		
High Pres Override Cir B		Yes/No	—	Mode_28		
High Pres Override Cir C		Yes/No	—	Mode_29		
Low Superheat Circuit A		Yes/No	—	Mode_30		
Low Superheat Circuit B		Yes/No	—	Mode_31		
Low Superheat Circuit C		Yes/No	—	Mode_32		

\*Not supported.

†The forced value will be used.



## APPENDIX C — CCN TABLES (cont)

### STATUS DISPLAY TABLES (cont)

TABLE	DISPLAY NAME	RANGE	UNITS	POINT NAME	WRITE STATUS
QCK_TST1	Quick Test Enable	no/Yes	—	Q_TSTRQ	forcible
	Circuit A EXV Position	0 - 100	%	Q_EXVA	forcible
	Circuit B EXV Position	0 - 100	%	Q_EXVB	forcible
	Circuit C EXV Position	0 - 100	%	Q_EXVC	forcible
	Cir A Economizer EXV Pos	0 - 100	%	Q_ECO_A	forcible
	Cir B Economizer EXV Pos	0 - 100	%	Q_ECO_B	forcible
	Cir C Economizer EXV Pos	0 - 100	%	Q_ECO_C	forcible
	Circuit A Fan Stages	0-10	—	Q_FAN_A	forcible
	Circuit B Fan Stages	0-10	—	Q_FAN_B	forcible
	Circuit C Fan Stages	0-10	—	Q_FAN_C	forcible
	Circuit A Head Press Speed	0 - 100	%	Q_VFANA	forcible
	Circuit B Head Press Speed	0 - 100	%	Q_VFANB	forcible
	Circuit C Head Press Speed	0 - 100	%	Q_VFANC	forcible
	Circuit A Oil Heater	Off/On	—	Q_HT_A	forcible
	Circuit A Oil Solenoid	Off/On	—	Q_OILS_A	forcible
	Circuit A Slide Valve 1	Off/On	—	Q_SLI_1A	forcible
	Circuit A Slide Valve 2	Off/On	—	Q_SLI_2A	forcible
	Cir A Heater Ball Valve	Off/On	—	Q_BVL_A	forcible
	Cir A Hot Gas Bypass	Off/On	—	Q_HGBP_A	forcible
	Cir A DGT Cool Solenoid	Off/On	—	Q_CDGT_B	forcible
	Circuit B Oil Heater	Off/On	—	Q_HT_B	forcible
	Circuit B Oil Solenoid	Off/On	—	Q_OILS_B	forcible
	Circuit B Slide Valve 1	Off/On	—	Q_SLI_1B	forcible
	Circuit B Slide Valve 2	Off/On	—	Q_SLI_2B	forcible
	Cir B Heater Ball Valve	Off/On	—	Q_BVL_B	forcible
	Cir B Hot Gas Bypass	Off/On	—	Q_HGBP_B	forcible
	Cir B DGT Cool Solenoid	Off/On	—	Q_CDGT_B	forcible
	Circuit C Oil Heater	Off/On	—	Q_HT_C	forcible
	Circuit C Oil Solenoid	Off/On	—	Q_OILS_C	forcible
	Circuit C Slide Valve 1	Off/On	—	Q_SLI_1C	forcible
	Circuit C Slide Valve 2	Off/On	—	Q_SLI_2C	forcible
	Cir C Heater Ball Valve	Off/On	—	Q_BVL_C	forcible
	Cir C Hot Gas Bypass	Off/On	—	Q_HGBP_C	forcible
	Cooler Heater Output	Off/On	—	Q_CL_HT	forcible
	Water Exchanger Pump 1	Off/On	—	Q_PMP1	forcible
	Water Exchanger Pump 2	Off/On	—	Q_PMP2	forcible
	Condenser Pump 1	Off/On	—	Q_HPMP1	forcible
	Condenser Pump 2*	Off/On	—	Q_HPMP2	forcible
	Chiller Ready Output	Off/On	—	Q_READY	forcible
	Chiller Running Output	Off/On	—	Q_RUN	forcible
	Customer Shutdown Out*	Off/On	—	Q_SHUT	forcible
	Alarm Relay Output	Off/On	—	Q_ALARM	forcible
	Alert Relay Output	Off/On	—	Q_ALERT	forcible
	Cir A Running Output*	Off/On	—	Q_RUN_A	forcible
	Cir B Running Output*	Off/On	—	Q_RUN_B	forcible
	Cir C Running Output*	Off/On	—	Q_RUN_C	forcible
	Chiller Capacity in 0-10v	0 - 10.0	volt	Q_CATO	forcible

\*Not supported.

NOTE: Disable quick test: all the quick test parameters shall be reset to 0.

TABLE	DISPLAY NAME	RANGE	UNITS	POINT NAME	WRITE STATUS
QCK_TST2*	Quick Test Enable	no/Yes	—	Q_TSTRQ	forcible
	Air Cond Enter Valve A	Off/On	—	Q_HREA_A	forcible
	Air Cond Leaving Valv A	Off/On	—	Q_HRLA_A	forcible
	Water Cond Enter Valv A	Off/On	—	Q_HREW_A	forcible
	Water Cond Leav Valve A	Off/On	—	Q_HRLW_A	forcible
	Air Cond Enter Valve B	Off/On	—	Q_HREA_B	forcible
	Air Cond Leaving Valv B	Off/On	—	Q_HRLA_B	forcible
	Water Cond Enter Valv B	Off/On	—	Q_HREW_B	forcible
	Water Cond Leav Valve B	Off/On	—	Q_HRLW_B	forcible
	HR Condenser Heater	Off/On	—	Q_CD_HT	forcible
	4 way Valve Circuit A	Off/On	—	Q_RV_A	forcible
	4 way Valve Circuit B	Off/On	—	Q_RV_B	forcible
	Free Cooling Heater	On/Off	—	Q_FC_HTR	forcible
	Free Cool A EXV Position	0 - 100	%	Q_FCEXVA	forcible
	Free Cool B EXV Position	0 - 100	%	Q_FCEXVB	forcible
	Free Cool A Ball Valve	Off/On	—	Q_FCBVL_A	forcible
	Free Cool B Ball Valve	Off/On	—	Q_FCBVL_B	forcible

\*Not supported.

NOTE: Disable quick test: all the quick test parameters shall be reset to 0.

TABLE	DISPLAY NAME	RANGE	UNITS	POINT NAME	WRITE STATUS
SERV_TST	Service Test Enable*	no/Yes	—	Q_STREQ	forcible
	Compressor A Output	Off/On	—	Q_CPA	forcible
	Slide Valve Capacity A	0 - 2†	—	Q_SLIA	forcible
	Compressor B Output	Off/On	—	Q_CPB	forcible
	Slide Valve Capacity B	0 - 2†	—	Q_SLIB	forcible
	Compressor C Output	Off/On	—	Q_CPC	forcible
Slide Valve Capacity C	0 - 2†	—	Q_SLIC	forcible	

\*Yes = service test function enable.

†0 = capacity frozen (unchanged).

1 = capacity increase.

2 = capacity decrease.

**APPENDIX C — CCN TABLES (cont)**  
**STATUS DISPLAY TABLES (cont)**

TABLE	DISPLAY NAME	RANGE	UNITS	POINT NAME
FREECOOL*	GENERAL PARAMETERS			
	Free Cooling Disable ?	Yes/No	—	FC_DSBLE
	LWT – OAT Delta	±nnn.n	°F	fc_delta
	Current Cooling Power	nnn	°F	cool_pwr
	Estimated FreeCoo Power	nnn	°F	fc_pwr
	Next Session Allowed In	nn	minutes	fc_next
	Cooling/FreeCool Timeout	nn	minutes	fc_tmout
	Free Cool Conditions OK ?	Yes/No	—	fc_ready
	Free Cool Request ?	Yes/No	—	fc_reqst
	Valve Actuators Heaters ?	On/Off	—	FC_HTR
	CIRCUIT A			
	Free Cooling Active	Yes/No	—	fc_on_a
	Fan Staging Number	1 to 6	—	FAN_ST_A
	3 Way Valve Position	nnn	%	fc_vlv_a
	3 Way Valve Status	Opening/Closing/...	—	FC_VLV_A
	Refrigerant Pump Out	On/Off	—	fc_pmp_a
	Pump Inlet Pressure	±nnn	kPa	fc_inp_a
	Pump Outlet Pressure	±nnn	kPa	fc_oup_a
	Pump Differential Pressure	±nnn	kPa	fc_dp_a
	EXV Position	nnn.n	%	EXV_A
	CIRCUIT B			
	Free Cooling Active	Yes/No	—	fc_on_b
	Fan Staging Number	1 to 6	—	FAN_ST_B
	3 Way Valve Position	nnn	%	fc_vlv_b
	3 Way Valve Status	Opening/Closing/...	—	FC_VLV_B
	Refrigerant Pump Out	On/Off	—	fc_pmp_b
	Pump Inlet Pressure	±nnn	kPa	fc_inp_b
	Pump Outlet Pressure	±nnn	kPa	fc_oup_b
	Pump Differential Pressure	±nnn	kPa	fc_dp_b
	EXV Position	nnn.n	%	EXV_B
	CIRCUIT C			
	Free Cooling Active	Yes/No	—	fc_on_c
	Fan Staging Number	1 to 6	—	FAN_ST_C
	3 Way Valve Position	nnn	%	fc_vlv_c
	3 Way Valve Status	Opening/Closing/...	—	FC_VLV_C
	Refrigerant Pump Out	On/Off	—	fc_pmp_c
	Pump Inlet Pressure	±nnn	kPa	fc_inp_c
	Pump Outlet Pressure	±nnn	kPa	fc_oup_c
	Pump Differential Pressure	±nnn	kPa	fc_dp_c
	EXV Position	nnn.n	%	EXV_C

\*Not supported.

## APPENDIX C — CCN TABLES (cont)

### STATUS DISPLAY TABLES (cont)

TABLE	DISPLAY NAME	RANGE	UNITS	POINT NAME	WRITE STATUS
RECLAIM*	Heat Reclaim Select	Yes/no		RECL_SEL	
	Reclaim Condenser Pump	On/Off		CONDPUMP	
	Reclaim Condenser Flow	On/Off		CONDFLOW	
	Reclaim Condenser Heater	On/Off		cond_htr	
	Reclaim Entering Fluid	±nnn.n	°F	HR_EWT	
	Reclaim Leaving Fluid	±nnn.n	°F	HR_LWT	
	Reclaim Fluid Setpoint	±nnn.n	°F	RSP	forcible
	Reclaim Valve Position	±nnn.n	%	hr_v_pos	
	HEAT RECLAIM CIRCUIT A				
	Reclaim Status Circuit A	n		hrstat_a	
	Pumpdown Pressure Cir A	±nnn.n	psi	PD_P_A	
	Sub Condenser Temp Cir A	±nnn.n	°F	hr_subta	
	Pumpdown Saturated Tmp A	±nnn.n	°F	hr_sat_a	
	Subcooling Temperature A	±nnn.n	°F	hr_subca	
	Air Cond Entering Valv A	On/Off	°F	hr_ea_a	
	Water Cond Enter Valve A	On/Off	°F	hr_ew_a	
	Air Cond Leaving Valve A	On/Off	°F	hr_la_a	
	Water Cond Leaving Val A	On/Off	°F	hr_lw_a	
	HEAT RECLAIM CIRCUIT B				
	Reclaim Status Circuit B	n		hrstat_b	
	Pumpdown Pressure Cir B	±nnn.n	psi	PD_P_B	
	Sub Condenser Temp Cir B	±nnn.n	°F	hr_subtb	
	Pumpdown Saturated Tmp B	±nnn.n	°F	hr_sat_b	
	Subcooling Temperature B	±nnn.n	°F	hr_subcb	
	Air Cond Entering Valv B	On/Off	°F	hr_ea_b	
	Water Cond Enter Valve B	On/Off	°F	hr_ew_b	
	Air Cond Leaving Valve B	On/Off	°F	hr_la_b	
	Water Cond Leaving Val B	On/Off	°F	hr_lw_b	
STATEGEN	UNIT DISCRETE IN				
	On/Off – Remote Switch	Open/Clse		ONOFF_SW	
	Remote Heat/Cool Switch	Open/Clse		HC_SW	
	Current Control	Off, On Cool, On Heat, On Auto		on_ctrl	
	Remote Reclaim Switch	Open/Clse		RECL_SW	
	Free Cooling Disable Switch*	Open/Clse		FC_SW	
	Remote Setpoint Switch	Open/Clse		SETP_SW	
	Limit Switch 1 Status	Open/Clse		LIM_SW1	
	Limit Switch 2 Status	Open/Clse		LIM_SW2	
	Occupied Override Switch	Open/Clse		OCC_OVSW	
	Ice Done Storage Switch	Open/Clse		ICE_SW	
	Cooler Flow Switch	Open/Clse		FLOW_SW	
	Cooler Pump Run Status	Open/Clse		CPUMPDEF	
	Condenser Flow Status	On/Off		CONDFLOW	
	Remote Interlock Status	Open/Clse		REM_LOCK	
	Electrical Box Interlock*	Open/Clse		ELEC_BOX	
	UNIT DISCRETE OUT				
	Cooler Flow Setpoint Out*	On/Off		SET_FLOW	
	Heater Switch	On/Off		HEAT_SW	
	Electrical Heat Stage*	0-4/Off		EHS_STEP	
	Cooler Pump #1 Command	On/Off		CPUMP_1	forcible
	Cooler Pump #2 Command	On/Off		CPUMP_2	forcible
	Rotate Cooler Pumps ?	Yes/No		ROTCPUMP	forcible
	Condenser Pump #1 Out*	On/Off		HPUMP_1	forcible
	Condenser Pump #2 Out*	On/Off		HPUMP_2	forcible
	Rotate Condenser Pumps?*	Yes/No		ROTHPUMP	forcible
	Cooler Heater Command	On/Off		COOLHEAT	
	Shutdown Indicator State	On/Off		SHUTDOWN	
	Alarm Relay Status	On/Off		ALARMOUT	
	Alert Relay Status	On/Off		ALERT	
	Ready or Running Status	On/Off		READY	
	Running Status	On/Off		RUNNING	
	UNIT ANALOG				
	Cooler Entering Fluid	±nnn.n	°F	COOL_EWT	
	Cooler Leaving Fluid	±nnn.n	°F	COOL_LWT	
	Condenser Entering Fluid	±nnn.n	°F	COND_EWT	
	Condenser Leaving Fluid	±nnn.n	°F	COND_LWT	
	Cooler Heater Temp*	±nnn.n	°F	HEATER	
	Circuit C Heater Temp*	±nnn.n	°F	T_HEAT_C	
	Optional Space Temp	±nnn.n	°F	SPACETMP	
	CHWS Temperature	±nnn.n	°F	CHWSTEMP	
	Reset/Setpnt 4-20mA Sgnl	±nn.n	ma	SP_RESET	
	Limit 4-20mA Signal	±nn.n	ma	LIM_ANAL	
	Chiller Capacity Signal	±nn.n	volts	CAPT_010	
STRTHOUR	Machine Operating Hours	nnnnn	hours	HR_MACH	
	Machine Starts Number	nnnnn		st_mach	
	Compressor A Hours	nnnnn	hours	HR_CP_A	
	Compressor A Starts	nnnnn		st_cp_a	
	Compressor B Hours	nnnnn	hours	HR_CP_B	
	Compressor B Starts	nnnnn		st_cp_b	
	Compressor C Hours	nnnnn	hours	HR_CP_C	
	Compressor C Starts	nnnnn		st_cp_c	
	WATER PUMPS				
	Cooler Pump #1 Hours	nnnnn	hours	hr_cpum1	
	Cooler Pump #2 Hours	nnnnn	hours	hr_cpum2	
	Condenser Pump #1 Hours*	nnnnn	hours	hr_hpum1	
	Condenser Pump #2 Hours*	nnnnn	hours	hr_hpum2	

\*Not supported.

## APPENDIX C — CCN TABLES (cont)

### CONFIGURATION TABLES

TABLE	DISPLAY NAME	RANGE	DEFAULT	UNITS	POINT NAME
!CtrlrID/PD5_XAXQ	Device Name	8 chars	30XW		DevDesc
	Description	24 chars	PRO-DIALOG 5 30XA XQ XW		
	Location	24 chars			Location
	Software Part Number	16 chars	CSA-SR-20C47nnnn		PartNum
	Model Number	20 chars			ModelNum
	Serial Number	12 chars			SerialNo
	Reference Number	24 chars			RefNum
	CCN Bus Number	0-239	0		CCNB
	CCN Element Number	1-239	1		CCNA
	CCN Baud Rate	9600 19200 38400	9600		BAUD
ALARMDEF/ ALARMS01	Alarm Routing Control	0-11111111	00000000		ALRM_CNT
	Alarm Equipment Priority	0-7	4		EQP_TYP
	Comm Failure Retry Time	1-240	10	min	RETRY_TM
	Realarm Time	1-255	30	min	RE_ALARM
	Alarm System Name	8 chars	PRO_XAXQ		ALRM_NAM
BRODEFS/ BROCASTS	Activate	0=Unused 1=Broadcast time, date, holiday flag and OAT. 2=For Standalone chiller. Daylight savings time & holiday determi- nation will be done without broadcasting through the bus.	2	—	ccnbroad
	OAT Broadcast				
	Bus #	0 to 239	0		oatbusnm
	Element #	0 to 239	0		oatlocad
	DAYLIGHT SAVING SELECT	Disable/Enable	Disable		dayl_sel
	ENTERING				
	Month	1 to 12	3		startmon
	Day of week* (1=Monday)	1 to 7	7		startdow
	Week Number of Month†	1 to 5	5		startwom
	LEAVING				
Month	1 to 12	10		Stopmon	
Day of week* (1=Monday)	1 to 7	7		Stoptdow	
Week Number of Month†	1 to 5	5		stopwom	
HOLIDAY/HOLDY_nn nn = 01 to 16	Holiday Start Month	0-12	0		HOL_MON
	Start Day	0-31	0		HOL_DAY
	Duration (days)	0-99	0		HOL_LEN
OCCDEFCS/ OCCnP0nS n = 1 or 2	Timed Override Hours	0-4	0		OVR_EXT
	Period 1 DOW (MTWTFSSH)	0/1	11111111		DOW1
	Occupied From	00:00-24:00	00:00		OCCTOD1
	Occupied To	00:00-24:00	24:00		UNOCTOD1
	Period 2 DOW (MTWTFSSH)	0/1	11111111		DOW2
	Occupied From	00:00-24:00	00:00		OCCTOD2
	Occupied To	00:00-24:00	00:00		UNOCTOD2
	Period 3 DOW (MTWTFSSH)	0/1	00000000		DOW3
	Occupied From	00:00-24:00	00:00		OCCTOD3
	Occupied To	00:00-24:00	00:00		UNOCTOD3
	Period 4 DOW (MTWTFSSH)	0/1	00000000		DOW4
	Occupied From	00:00-24:00	00:00		OCCTOD4
	Occupied To	00:00-24:00	00:00		UNOCTOD4
	Period 5 DOW (MTWTFSSH)	0/1	00000000		DOW5
	Occupied From	00:00-24:00	00:00		OCCTOD5
	Occupied To	00:00-24:00	00:00		UNOCTOD5
	Period 6 DOW (MTWTFSSH)	0/1	00000000		DOW6
	Occupied From	00:00-24:00	00:00		OCCTOD6
	Occupied To	00:00-24:00	00:00		UNOCTOD6
	Period 7 DOW (MTWTFSSH)	0/1	00000000		DOW7
	Occupied From	00:00-24:00	00:00		OCCTOD7
	Occupied To	00:00-24:00	00:00		UNOCTOD7
	Period 8 DOW (MTWTFSSH)	0/1	00000000		DOW8
	Occupied From	00:00-24:00	00:00		OCCTOD8
	Occupied To	00:00-24:00	00:00		UNOCTOD8

\*Day of week where daylight savings time will occur in the morning (at 2:00 am). Daylight savings time occurs on Sunday (7) morning, 1 hour shall be added when entering and 1 hour subtracted when leaving.

†Date once selected (from 1) shall occur in the week number entered. 1: If day of week selected is 7 (Sunday) time change will occur the first Sunday (week number 1) in the month. 5: If day of week selected is 7 (Sunday) time change will occur the last Sunday of the month (week number 4 or 5).

NOTE: nnnn is software version.

**APPENDIX C — CCN TABLES (cont)**  
**CONFIGURATION TABLES (cont)**

TABLE	DISPLAY NAME	RANGE	DEFAULT	UNITS	POINT NAME	
<b>CFG_TABn</b> (n = 1 to 8)	Display n table number 1	nn			tab_nb_1	
	Display n var number 1	nn			var_nb_1	
	Display n table number 2	nn			tab_nb_2	
	Display n var number 2	nn			var_nb_2	
	Display n table number 3	nn			tab_nb_3	
	Display n var number 3	nn			var_nb_3	
	Display n table number 4	nn			tab_nb_4	
	Display n var number 4	nn			var_nb_4	
	Display n table number 5	nn			tab_nb_5	
	Display n var number 5	nn			var_nb_5	
<b>DISPCONF</b>	Metric Display on STDU Language Selection	Yes/No 0=English 1=Espanol 2=Francais 3=Portugues 4=Translated	No 0		DISPUNIT LANGUAGE	
	<b>MST_SLV</b>	MASTER SLAVE CONTROL Master/Slave Select	0=Disable 1=Master 2=Slave	0		ms_sel
		Master Control Type	1=Local Control 2=Remote Control 3=CCN Control	1		ms_ctrl
		Slave Address	1 to 236	2		slv_addr
		Lead Lag Select	0=Always Lead 1=Lag Once Failed Only 2=Lead/Lag Runtime Sel	0		lead_sel
		Lead/Lag Balance Delta	40 to 400	168	hours	ll_bal_d
		Lag Start Timer	2 to 30	10	min	lstr_tim
		Lead Pulldown Time	0 to 60	0	min	lead_pul
		Start if Error Higher		4	^F	start_dt
Lag Minimum Running Time			0	min	lag_mini	
Lag Unit Pump Control		0=Stop if Unit Stops 1=Run if Unit Stops	0		lag_pump	
Chiller in Series	Yes/No	No		ll_serie		

**APPENDIX C — CCN TABLES (cont)**  
**CONFIGURATION TABLES (cont)**

TABLE	DISPLAY NAME	RANGE	DEFAULT	UNITS	POINT NAME
USER	Circuit Loading Sequence	0-3 0=Auto, 1=A Lead 2=B Lead, 3=C Lead	0		lead_cir
	Staged Loading Sequence Ramp Loading Select Unit Off to On Delay Condenser Pumps Sequence Cooler Pumps Sequence	No/Yes No/Yes 1-15† 0-4* 0-4 0=No Pump 1=One Pump Only 2=Two Pumps Auto 3=Pump#1 Manual 4=Pump#2 Manual	No No 1 0 0	min	seq_typ ramp_sel off_on_d hpumpseq cpumpseq
	Pump Auto Rotation Delay Pump Sticking Protection Stop Pump During Standby Flow Checked if Pump Off Auto Changeover Select* Cooling Reset Select Heating Reset Select*	24-3000 No/Yes No/Yes No/Yes No/Yes 0-4 0-4 0=None 1=OAT, 2=Delta T, 3=4-20mA Control 4=Space Temp	48 No No No No 0 0	hours	pump_del pump_per pump_sby pump_loc auto_sel cr_sel hr_sel
	Demand Limit Type Select	0-2 0=None 1=Switch Control 2=4-20mA Control	0		lim_sel
	mA For 100% Demand Limit mA For 0% Demand Limit Current Limit Select Current Limit at 100% Heating OAT Threshold* Free Cooling Delta T Th* Full Load Timeout HSM Both Command Select	0-20 0-20 No/Yes 0 to 2000 -4-32 14.4-27 20-300 No/Yes	0 10 No 2000 5 18 30 No	ma ma amps °F °F min	lim_mx lim_ze curr_sel curr_ful heat_th free_dt fc_tmout both_sel
	NIGHT CONTROL Start Hour End Hour Capacity Limit Ice Mode Enable Reverse Alarms Relay Cooler pump off in heat Cond pump off in cool	00:00-24:00 00:00-24:00 0-100 No/Yes No/Yes No/Yes No/Yes	00:00 00:00 100 No No No No	%	nh_start nh_end nh_limit ice_cnfg al_rever stopheat stopcool

\*Not supported.  
†Do not configure for 0.

**NOTES:**

- Flow checked if pump off needed when a command is sent to the primary pump to prevent cooler from freezing in winter conditions. Command will set the cooler flow switch to closed while the controls stop the cooler pump. The controls may then generate an alarm. If this decision is active, the cooler flow switch is not checked when the cooler pump is stopped.

- If cooling reset select set point has been selected the set point based on 4-20mA input signal through *ComfortLink™* control, then a 4-20 mA reset function shall be ignored. Configuration 3 (4-20mA Control) and 4 (Space Temperature) shall require an Energy Management Module.
- Configuration 2 (4-20mA Control) shall require an Energy Management Module. Configuration 1 Switch Demand limit provides 3 step demand limit if an Energy Management Module is present. Otherwise, only one step is allowed.
- Reverse Alarms Relay configuration will be deenergized when an alarm and alert relay is present and will be energized when no alarm is present.

## APPENDIX C — CCN TABLES (cont)

### SETPOINT CONFIGURATION TABLES

TABLE	DISPLAY NAME	RANGE	DEFAULT	UNITS	POINT NAME	
SETPOINT	COOLING					
	Cooling Setpoint 1	-20-70	44.0	°F	csp1	
	Cooling Setpoint 2	-20-70	44.0	°F	csp2	
	Cooling Ice Setpoint	-20-70	44.0	°F	ice_sp	
	OAT No Reset Value	14-125	14.0	°F	oatcr_no	
	OAT Full Reset Value	14-125	14.0	°F	oatcr_fu	
	Delta T No Reset Value	0-25	0.0	^F	dt_cr_no	
	Delta T Full Reset Value	0-25	0.0	^F	dt_cr_fu	
	Current No Reset Value	0-20	0.0	ma	v_cr_no	
	Current Full Reset Value	0-20	0.0	ma	v_cr_fu	
	Space T No Reset Value	14-125	14.0	°F	spacr_no	
	SpaceT Full Reset Value	14-125	14.0	°F	spacr_fu	
	Cooling Reset Deg. Value	-30-30	0.0	^F	cr_deg	
	Cooling Ramp Loading	0.2-2.0	1.0	^F	cramp_sp	
	HEATING*					
	Heating Setpoint 1	80-140	100.0	°F	hsp1	
	Heating Setpoint 2	80-140	100.0	°F	hsp2	
	OAT No Reset Value	14-125	14.0	°F	oathr_no	
	OAT Full Reset Value	14-125	14.0	°F	oathr_fu	
	Delta T No Reset Value	0-25	0.0	^F	dt_hr_no	
	Delta T Full Reset Value	0-25	0.0	^F	dt_hr_fu	
	Current No Reset Value	0-20	0.0	ma	v_hr_no	
	Current Full Reset Value	0-20	0.0	ma	v_hr_fu	
	Heating Reset Deg. Value	-30-30	0.0	^F	hr_deg	
	Heating Ramp Loading	0.2-2.0	1.0	^F	hramp_sp	
	AUTO CHANGEOVER*					
	Cool Changeover Setpt	39-122	75.0	°F	cauto_sp	
	Heat Changeover Setpt	32-115	64.0	°F	hauto_sp	
	MISCELLANEOUS					
	Switch Limit Setpoint 1	0-100	100	%	lim_sp1	
	Switch Limit Setpoint 2	0-100	100	%	lim_sp2	
	Switch Limit Setpoint 3	0-100	100	%	lim_sp3	
	Reclaim Setpoint*	95-140	122.0	°F	rsp	
	Reclaim Deadband*	5-27	9.0	°F	hr_deadb	
	Water Val Condensing Stp*	80 to 120	86	°F	w_sct_sp	

\*Not supported.

### MAINTENANCE DISPLAY TABLES

TABLE	DISPLAY NAME	RANGE	UNITS	POINT NAME	WRITE STATUS
BOARD_PN	EXV Board Circuit A	XXXXXXXXXX		exv_brda	
	EXV Board Circuit B	XXXXXXXXXX		exv_brdb	
	EXV Board Circuit C	XXXXXXXXXX		exv_brdc	
	AUX Board #1 Part Number	XXXXXXXXXX		aux_brd1	
	AUX Board #2 Part Number	XXXXXXXXXX		aux_brd2	
	AUX Board #3 Part Number	XXXXXXXXXX		aux_brd3	
	AUX Board #4 Part Number	XXXXXXXXXX		aux_brd4	
	AUX Board #5 Part Number	XXXXXXXXXX		aux_brd5	
	EMM NRCP2 Board	XXXXXXXXXX		emm_nrcp	
	Reclaim NRCP2 Board	XXXXXXXXXX		rec_nrcp	
	TCPM Board Comp A	XXXXXXXXXX		cpa_vers	
	Must Trip Amps	0-600	amps	cpa_mtam	
	S1 Config Switch (8 to 1)	00000000	0	cpa_s1_m	
	TCPM Board Comp B	nnnn		cpb_vers	
	Must Trip Amps	0-600	amps	cpb_mtam	
	S1 Config Switch (8 to 1)	00000000	0	cpb_s1_m	
	TCPM Board Comp C	XXXXXXXXXX		cpc_vers	
Must Trip Amps	0-600	amps	cpc_mtam		
S1 Config Switch (8 to 1)	00000000	0	cpc_s1_m		
CUR_PHASE	Current Phase 1 Comp A	0-600	amps	cpa_cur1	
	Current Phase 2 Comp A	0-600	amps	cpa_cur2	
	Current Phase 3 Comp A	0-600	amps	cpa_cur3	
	Current Phase 1 Comp B	0-600	amps	cpb_cur1	
	Current Phase 2 Comp B	0-600	amps	cpb_cur2	
	Current Phase 3 Comp B	0-600	amps	cpb_cur3	
	Current Phase 1 Comp C	0-600	amps	cpc_cur1	
	Current Phase 2 Comp C	0-600	amps	cpc_cur2	
	Current Phase 3 Comp C	0-600	amps	cpc_cur3	
	DEFROSTM*	CIR A DEFROST CONTROL			
Exchanger Frost Factor		0-100	%	frost_a	
Next Sequence Allowed in Defrost Active?		nnn	minutes	def_se_a	
Defrost Temperature		True/False		mode[19]	
Defrost Duration		±nnn.n	°F	DEFRT_A	
Fan Sequence Started ?		nnn	minutes	defr_dua	
Override State		n		def_fa_a	
Mean SST Calculation		nn		over_d_a	
Delta: OAT - Mean SST		±nnn.n	°F	sst_dm_a	
Reference Delta		±nnn.n	^F	delt_a	
Delta - Reference Delta		±nnn.n	^F	delt_r_a	
Frost Integrator Gain		±nnn.n	°F	del_v_a	
Defrost Fan Start Cal A		n.n		fr_int_a	
Defrost Fan Offset Cal A		0.00	psi	def_ca_a	
		0.00	psi	def_of_a	
CIR B DEFROST CONTROL					
Exchanger Frost Factor		0-100	%	frost_b	
Next Sequence Allowed in Defrost Active?		nnn	minutes	def_se_b	
Defrost Temperature		True/False		mode[20]	
Defrost Duration		±nnn.n	°F	DEFRT_B	
Fan Sequence Started?		nnn	minutes	defr_dub	
Override State		n		def_fa_b	
Mean SST calculation		nn		over_d_b	
Delta: OAT - Mean SST		±nnn.n	°F	sst_dm_b	
Reference Delta		±nnn.n	^F	delt_b	
Delta - Reference Delta		±nnn.n	^F	delt_r_b	
Frost Integrator Gain		±nnn.n	^F	del_v_b	
Defrost Fan Start Cal B		n.n		fr_int_b	
Defrost Fan Offset Cal B		0.00	psi	def_ca_b	
		0.00	psi	def_of_b	

\*Not supported.

NOTES: Tables for display only. Forcing shall not be supported on this maintenance screen.

**APPENDIX C — CCN TABLES (cont)**  
**MAINTENANCE DISPLAY TABLES (cont)**

TABLE	DISPLAY NAME	RANGE	UNITS	POINT NAME	WRITE STATUS
FANCTRL	Cir A SCT Control Point	±nnn.n	°F	sct_sp_a	
	Cir A SCT Candidate	±nnn.n	°F	sct_fu_a	
	Cir B SCT Control Point	±nnn.n	°F	sct_sp_b	
	Cir B SCT Candidate	±nnn.n	°F	sct_fu_b	
	Cir C SCT Control Point	±nnn.n	°F	sct_sp_c	
	Cir C SCT Candidate	±nnn.n	°F	sct_fu_c	
	Circuit A Fan Power Drive			drva_pwt	
	Circuit A Fan Drive Amps			drva_i	
	Fan A Drive Attach			SET_A_DRVA	
	Fan B Drive Attach			SET_B_DRVA	
	Fan C Drive Attach			SET_C_DRVA	
LAST_POR	Power On 1: day-mon-year	nnnnnn	ddmmyy	date_on1	
	Power On 1: hour-minute	nnnn	hhmm	time_on1	
	PowerDown 1:day-mon-year	nnnnnn	ddmmyy	date_of1	
	PowerDown 1:hour-minute	nnnn	hhmm	time_of1	
	Power On 2: day-mon-year	nnnnnn	ddmmyy	date_on2	
	Power On 2: hour-minute	nnnn	hhmm	time_on2	
	PowerDown 2:day-mon-year	nnnnnn	ddmmyy	date_of2	
	PowerDown 2:hour-minute	nnnn	hhmm	time_of2	
	Power On 3: day-mon-year	nnnnnn	ddmmyy	date_on3	
	Power On 3: hour-minute	nnnn	hhmm	time_on3	
	PowerDown 3:day-mon-year	nnnnnn	ddmmyy	date_of3	
	PowerDown 3:hour-minute	nnnn	hhmm	time_of3	
	Power On 4: day-mon-year	nnnnnn	ddmmyy	date_on4	
	Power On 4: hour-minute	nnnn	hhmm	time_on4	
	PowerDown 4:day-mon-year	nnnnnn	ddmmyy	date_of4	
	PowerDown 4:hour-minute	nnnn	hhmm	time_of4	
	Power On 5: day-mon-year	nnnnnn	ddmmyy	date_on5	
	Power On 5: hour-minute	nnnn	hhmm	time_on5	
	PowerDown 5:day-mon-year	nnnnnn	ddmmyy	date_of5	
	PowerDown 5:hour-minute	nnnn	hhmm	time_of5	
LOADFACT	CAPACITY CONTROL				
	Average Ctrl Water Temp	±nnn.n	°F	ctrl_avg	
	Differential Water Temp	±nnn.n	°F	diff_wt	
	Water Delta T	±nnn.n	°F	delta_t	
	Control Point	±nnn.n	°F	CTRL_PNT	
	Reset Amount	±nnn.n	°F	reset	
	Controlled Temp Error	±nnn.n	°F	tp_error	
	Actual Capacity	nnn	%	cap_t	
	Actual Capacity Limit	nnn	%	cap_lim	
	Actual Chiller Current	nnnn	amps	TOT_CURR	
	Chiller Current Limit	nnnn	amps	CURR_LIM	
	Current At 30% Load A	nnnn	amps	cur_30_a	
	Current At 30% Load B	nnnn	amps	cur_30_b	
	Current At 30% Load C	nnnn	amps	cur_30_c	
	Current At 100% Load A	nnnn	amps	cur100_a	
	Current At 100% Load B	nnnn	amps	cur100_b	
	Current At 100% Load C	nnnn	amps	cur100_c	
	Current Z Multiplier Val	±n.n		zm	
	Load/Unload Factor	±nnn.n	0/0	smz	
	Active Capacity Override	nn		over_cap	
	EHS CAPACITY CONTROL*				
EHS Ctrl Override	nn		over_ehs		
Requested Electric Stage	nn		eh_stage		
Electrical Pulldown?	True/False		ehspulld		
EXV_CTRL	EXV CONTROL				
	EXV Position Circuit A	nnn.n	%	EXV_A	
	Discharge Superheat A	nnn.n	%	DSH_A	
	Suction Superheat A	nn.n	°F	SH_A	
	Suction SH Control Pt A	nn.n	°F	sh_sp_a	
	Cooler Exchange DT Cir A	nn.n	°F	pinch_a	
	Cooler Pinch Ctl Point A	nn.n	°F	pinch_spa	
	EXV Override Circuit A	nn		ov_exv_a	
	WC EXV Optimiz Status A				
	EXV Position Circuit B	nnn.n	%	EXV_B	
	Discharge Superheat B	nnn.n	%	DSH_B	
	Suction Superheat B	nn.n	°F	SH_B	
	Suction SH Control Pt B	nn.n	°F	sh_sp_b	
	Cooler Exchange DT Cir B	nn.n	°F	pinch_b	
	Cooler Pinch Ctl Point B	nn.n	°F	pinch_spb	
	EXV Override Circuit B	nn		ov_exv_b	
	WC EXV Optimiz status				
	EXV Position Circuit C	nnn.n	%	EXV_C	
	Discharge Superheat C	nnn.n	%	DSH_C	
	Suction Superheat C	nn.n	°F	SH_C	
	Suction SH Control Pt C	nn.n	°F	sh_sp_c	
	Cooler Exchange DT Cir C	nn.n	°F	pinch_c	
	Cooler Pinch Ctl Point C	nn.n	°F	pinch_spc	
	EXV Override Circuit C	nn		ov_exv_c	
	WC EXV Optimiz Status				
	ECONOMIZER CONTROL				
	Economizer Position A	nnn.n	%	EXV_EC_A	
	Economizer Superheat A	nn.n	°F	eco_sha	
	Economizer SH Setpoint A	nn.n	°F	ecsh_spa	
	EXV Override Circuit A	nn		ov_eco_a	
	Economizer Position B	nnn.n	%	EXV_EC_B	
	Economizer Superheat B	nn.n	°F	eco_shb	
	Economizer SH Setpoint B	nn.n	°F	ecsh_spb	
EXV Override Circuit B	nn		ov_eco_b		
Economizer Position C	nnn.n	%	EXV_EC_C		
Economizer Superheat C	nn.n	°F	eco_shc		
Economizer SH Setpoint C	nn.n	°F	ecsh_spc		
EXV Override Circuit C	nn		ov_eco_c		

\*Not supported.



## APPENDIX C — CCN TABLES (cont)

### MAINTENANCE DISPLAY TABLES (cont)

TABLE	DISPLAY NAME	RANGE	UNITS	POINT NAME	WRITE STATUS
MSTSLAVE	MASTER/SLAVE CONTROL Unit is Master or Slave Master Control Type* Master/Slave Ctrl Active Lead Unit is the: Slave Chiller State†  Slave Chiller Total Cap Lag Start Delay** Lead/Lag Hours Delta Lead/Lag Changeover?*** Lead Pulldown? Master/Slave Error Max Available Capacity?†† Slave Lagstat	Disable/Master/Slave Local/Remote/CCN True/False Master/Slave 0=Chiller is off 1=Valid Run State in CCN Mode 2=Unused for this control 3=Chiller is in local mode 4=Power fail restart in progress 5=Shutdown due to fault 6=Communication failure 0-100 1-30 ±nnnnn Yes/No Yes/No nn True/False 0=Unit not configured as a slave chiller 1=Slave pump configuration error (ms_error=1) 2=Unit configured as slave chiller with lwt_opt=no (entering water control) with pump control (lag_pump=0) 3=Unit configured as slave chiller with lwt_opt=yes (leaving water control) with pump control (lag_pump=0) 4=Unit Configured as slave chiller with lwt_opt=no (entering water control) with no pump control (lag_pump=1) 5=Unit configured as slave chiller with lwt_opt=yes (leaving water control) with no pump control (lag_pump=1)	% minutes hours	mstslv ms_ctrl ms_activ lead_sel slv_stat  slv_capt l_strt_d ll_hr_d ll_chang ll_pull ms_error cap_max lagstat	

\*Always CCN for the slave chiller.

†Slave chiller chillstat value

\*\*This decision is consistent for master chiller only. It shall be set by default to 0 for the slave chiller.

††This item is true when chiller has loaded its total available capacity tonnage.

TABLE	DISPLAY NAME	RANGE	UNITS	POINT NAME	WRITE STATUS
OCCMAINT	Current Mode (1=occup.) Current Occp Period # Timed-Override in Effect Timed-Override Duration Current Occupied Time Current Unoccupied Time Next Occupied Day Next Occupied Time Next Unoccupied Day Next Unoccupied Time Prev Unoccupied Day Prev Unoccupied Time	0/1 1 to 8 Yes/No 0-4 00:00-23:59 00:00-23:59 Mon-Sun 00:00-23:59 Mon-Sun 00:00-23:59 Mon-Sun 00:00-23:59	hours	MODE PER_NO OVERLAST OVR_HRS STRTTIME ENDTIME NXTOCCDAY NXTOCTIM NXTUNDAY NXTUNTIM PRVUNDAY PRVUNTIM	

TABLE	DISPLAY NAME	RANGE	UNITS	POINT NAME	WRITE STATUS
PR_LIMIT	Discharge A Temp Average Discharge A Temp Rate Discharge A Gas Limit Suction A Temp Average Discharge B Temp Average Discharge B Temp Rate Discharge B Gas Limit Suction B Temp Average Discharge C Temp Average Discharge C Temp Rate Discharge C Gas Limit Suction C Temp Average	±nnn.n ±nnn.n ±nnn.n ±nnn.n ±nnn.n ±nnn.n ±nnn.n ±nnn.n ±nnn.n ±nnn.n ±nnn.n ±nnn.n	°F °F °F °F °F °F °F °F °F °F °F	sdt_m_a sdt_mr_a sdtlim_a sst_m_a sdt_m_b sdt_mr_b sdtlim_b sst_m_b sdt_m_c sdt_mr_c sdtlim_c sst_m_c	

NOTE: Table for display only. Used for Cooling and Heat Pump Compressor Envelope.

TABLE	DISPLAY NAME	RANGE	UNITS	POINT NAME	WRITE STATUS
SERMAINT	Reset Maintenance Alert 1 to 11: reset individually 12: reset all	nn		S_RESET	forcible
	OPERATION WARNINGS 1 — Refrigerant Charge 2 — Water Loop Size	Normal/Low/Disable Normal/Low/Disable		charge_m wloop_m	
	GENERAL SERVICING DELAYS 3 — Cooler Pump 1 (days) 4 — Cooler Pump 2 (days) 5 — Condenser Pump 1 (days) 6 — Condenser Pump 2 (days) 7 — Water Filter (days) 8 — Cp A Oil Filter (days) 9 — Cp B Oil Filter (days) 10 — C.P.C Oil Filter (days)	0-1000/Alert/Disable 0-1000/Alert/Disable 0-1000/Alert 0-1000/Alert 0-1000/Alert/Disable 0-1000/Alert 0-1000/alert 0-1000/Alert		cpump1_m cpump2_m hpump1_m hpump2_m wfilte_m ofiLta_m ofiLtb_m ofiLtc_m	

## APPENDIX C — CCN TABLES (cont)

### SERVICE CONFIGURATION TABLES

TABLE	DISPLAY NAME	RANGE	DEFAULT	UNITS	POINT NAME	WRITE STATUS
TABLE USED FOR DISABLE COMPRESSORS (see notes)						
<b>CP_UNABL</b> (See Notes)	Compressor A Disable Compressor B Disable Compressor C Disable*	No/Yes No/Yes No/Yes	No No No		un_cp_a un_cp_b un_cp_c	
<b>FACTORY</b> (See Notes)	Unit Type Unit Capacity Power Frequency 60HZ Sel Power Supply Voltage NB Fans on Varifan Cir A NB Fans on Varifan Cir B NB Fans on Varifan Cir C Soft Starter Select* Wye Delta Start Select Air Cooled Reclaim Sel* Free Cooling Select* Cooler Heater Select  Condenser Water Val Sel Hot Gas Bypass Select MCHX Exchanger Select DX Cooler Select Boiler Command Select* Energy Management Module High Tiers Display Selec  Factory Password Hydraulic Transducer Kit* Cooler Pass Number VLT Fan Drive Select* VLT Fan Drive rpm* High Condensing Select* Max Condenser LWT=45degC* Condenser probe select*	1 (Air Cooled) 2 (Heat Pump) 0 to 1800** Yes/No 200 to 660 0 to 6 0 to 6 0 to 6 Yes/No Yes/No Yes/No Yes/No 0 to 2 0 = No Heater 1 = Cooler Heater 2 = Future Yes/No Yes/No Yes/No Yes/No Yes/No Yes/No No = Use Navigator™ display as user interface (factory installed) Yes = Use Touch Pilot™ Display as user interface (factory installed) 0 to 9999 Yes/No 1 to 3 Yes/No Yes/No Yes/No	1 Nominal Unit Size Yes Nameplate Voltage 1 1 0 No No No No No No No No No No 111 No 2 0 0 No No No	volts	unit_typ  unitsize freq_60H voltage varfan_a varfan_b varfan_c softstar wye_delt recl_opt freecool heat_sel  cond_val hgbp_sel mchx_sel dx_sel boil_sel emm_nrcp highdisp  fac_pass kithydro cpass_nb vlt_sel vlt_rpm highcond max_clwt condprob	
<b>FACTORY2</b>	Compressor A Config Must Trip Amps S1 Config Switch (8 to 1)  Compressor B Config Must Trip Amps S1 Config Switch (8 to 1)  Compressor C Config Must Trip Amps S1 Config Switch (8 to 1)  Circuit A Total Fans NB Circuit B Total Fans NB Circuit C Total Fans NB EXV A Maximum Steps Numb EXV B Maximum Steps Numb EXV C Maximum Steps Numb Economizer A Steps Numb Economizer B Steps Numb Economizer C Steps Numb	0 to 600 00000000 (8 position dip switch configuration)  0 to 600 00000000 (8 position dip switch configuration)  0 to 600 00000000 (8 position dip switch configuration)  2 to 8 2 to 8 0 to 8 0/15000 0/15000 0/15000 0/15000 0/15000 0/15000	Refer to Appendix D Refer to Appendix D  Refer to Appendix D Refer to Appendix D  Refer to Appendix D Refer to Appendix D  3690 3690 3690 2785† 2785† 2785†		cpa_mtac cpa_s1_c  cpb_mtac cpb_s1_c  cpc_mtac cpc_s1_c  nb_fan_a nb_fan_b nb_fan_c exva_max exvb_max exvc_max eco_cnfa eco_cnf eco_cnfc	

\*Not supported.

†0 = No economizer.

\*\*Unit capacity should be entered as nominal size. For DX unit capacity unit capacity is nominal tonnage. i.e., 92 should be 90 and configure DX cooler select equal to yes.

**NOTES:**

1. Table used to disable compressors for maintenance purposes. The capacity control will consider that these compressors (once set to YES) are failed manually (no alarm will appear).
2. Enter unit size. This item allows the controls to determine capacity of each compressor and the total number of fans on each circuit based on a compressor arrangement array (can be viewed in table FACTORY2). It is not necessary to enter compressor capacity and number of fans on each circuit. See the 30XA Installation Instructions for more information.
3. Number of fans controlled directly by a variable speed fan actuator using 0 to 10 vdc signal. This will enable the controls to determine the remaining discrete fan staging outputs from the total fans on each circuit.

4. Used for extra functions with the purpose of energy management such as occupancy override switch, ice storage, setpoint reset, and demand limit.
5. Compressor capacity will be automatically determined if unit size entered in FACTORY table matches the values in the unit compressor configuration table.
6. Total number of fans includes fans controlled by a variable speed fan. This value will be automatically populated if unit size entered in FACTORY table matches the values in the unit compressor configuration table.

## APPENDIX C — CCN TABLES (cont)

### SERVICE CONFIGURATION TABLES (cont)

TABLE	DISPLAY NAME	RANGE	DEFAULT	UNITS	POINT NAME	WRITE STATUS
MAINTCFG	MAINTENANCE CONFIG					
	Servicing Alert	Enable/Disable	Disable		s_alert	
	Refrigerant Charge Ctrl	Enable/Disable	Disable		charge_c	
	Water Loop Control	Enable/Disable	Disable		wloop_c	
	CPump 1 Ctl Delay (days)	0-1000	0		cpump1_c	
	CPump 2 Ctl Delay (days)	0-1000	0		cpump2_c	
	HPump 1 Ctrl Delay (days)*	0-1000	0		hpump1_c	
	HPump 2 Ctrl Delay (days)*	0-1000	0		hpump2_c	
	Water Filter Ctrl (days)	0-1000	0		wfite_c	
	Oil Filter A Ctrl (days)	0 to 1000	0		oilfia_c	
	Oil Filter B Ctrl (days)	0 to 1000	0		oilfib_c	
	Oil Filter C Ctrl (days)	0 to 1000	0		oilfic_c	

\*Not supported.

TABLE	DISPLAY NAME	RANGE	DEFAULT	UNITS	POINT NAME	WRITE STATUS
SERVICE1	Cooler Fluid Type	1/2 1=Water 2=Brine	1		flui_typ	
	Flow Switch SP*	0-60	1		flow_sp	
	Brine Freeze Setpoint	-20.0-34.0	34	°F	freezesp	
	Brine Minimum Fluid Temp	10.0-34.0	38	°F	mini_lwt	
	Condenser Fluid Type*	1/2 1=Water 2=Brine	1		cond_typ	
	Entering Fluid Control	Yes/No	No		ewt_opt	
	Prop PID Gain Varifan	-20.0-20.0	2.0		hd_pg	
	Int PID Gain Varifan	-5.0-5.0	0.2		hd_ig	
	Deri PID Gain Varifan	-20.0-20.0	0.4		hd_dg	
	Maximum Ducted Fan Speed*	20-100	100		fan_max	
	EXV A Superheat Setpoint	7.2-44	14.4†		sh_sp_a	
	EXV B Superheat Setpoint	7.2-44	14.4†		sh_sp_b	
	EXV C Superheat Setpoint	7.2-44	14.4		sh_sp_c	
	Pinch offset circuit A	-5.4-5.4	0		p_ofst_a	
	Pinch offset circuit B	-5.4-5.4	0		p_ofst_b	
	Pinch offset circuit C	-5.4-5.4	-3.6		p_ofst_c	
	EXV MOP Setpoint	40-55	62		mop_sp	
	High Pressure Threshold	200-290	275.5		hp_psi	
	Cooler Heater Delta Spt	1-6	2		heatersp	
	Auto Start When SM Lost	Enable/Disable	Disable		auto_sm	
	3way Valve Min Position*	0-50	0		min_3w	
	3way Valve Max Position*	20-100	100		max_3w	
	Economizer SH Setpoint A	5-15	10.8		esh_sp_a	
	Economizer SH Setpoint B	5-15	10.8		esh_sp_b	
	Economizer SH Setpoint C	5-15	10.8		esh_sp_c	
	Fast Loading Sequence	0-4	0		fastload	
	EWT Probe on Cir A Side	Yes/No	Yes		ewt_cirA	
	Current Offset Cir A		0		cur_offA	amps
	Current Offset Cir B		0		cur_offB	amps
	Current Offset Cir C		0		cur_offC	amps

\*Not supported. Must be configured at default.

†Default superheat setpoint for DX cooler unit see table below:

SUPERHEAT SETPOINT FOR DX COOLER				
FLUID	CKT.	UNIT SIZE		
		082-242	262-302	327-352
Water LWT ≥ 40 F	A	15	10	10
	B	15	15	10
Brine LWT < 40 F	A	25	20	20
	B	25	25	20

NOTE: This table shall be downloadable at any time. However, modified value shall not be used by tasks until the unit is in OFF state. This shall not apply to the Varifan gains that shall be modified at any time and used immediately by the head pressure control tasks even if the unit is in operation.

**APPENDIX C — CCN TABLES (cont)**  
**SERVICE CONFIGURATION TABLES (cont)**

TABLE	DISPLAY NAME	RANGE	UNITS	POINT NAME	WRITE STATUS
<b>TABLE TO BE USED FOR RUN TIMES UPDATE IN CASE OF MBB REPLACEMENT</b>					
<b>UPDHRFAN</b>	Free Cooling A Pump Hours	0	hours	hr_fcp_a	
	Free Cooling B Pump Hours	0	hours	hr_fcp_b	
	Circuit A Defrost Number	0		nb_def_a	
	Circuit B Defrost Number	0		nb_def_b	
	Circuit A Fan #1 Hours	0	hours	hr_fana1	
	Circuit A Fan #2 Hours	0	hours	hr_fana2	
	Circuit A Fan #3 Hours	0	hours	hr_fana3	
	Circuit A Fan #4 Hours	0	hours	hr_fana4	
	Circuit A Fan #5 Hours	0	hours	hr_fana5	
	Circuit A Fan #6 Hours	0	hours	hr_fana6	
	Circuit A Fan #7 Hours	0	hours	hr_fana7	
	Circuit A Fan #8 Hours	0	hours	hr_fana8	
	Circuit A Fan #9 Hours	0	hours	hr_fana9	
	Circuit A Fan #10 Hours	0	hours	hrfana10	
	Circuit B Fan #1 Hours	0	hours	hr_fanb1	
	Circuit B Fan #2 Hours	0	hours	hr_fanb2	
	Circuit B Fan #3 Hours	0	hours	hr_fanb3	
	Circuit B Fan #4 Hours	0	hours	hr_fanb4	
	Circuit B Fan #5 Hours	0	hours	hr_fanb5	
	Circuit B Fan #6 Hours	0	hours	hr_fanb6	
	Circuit B Fan #7 Hours	0	hours	hr_fanb7	
	Circuit B Fan #8 Hours	0	hours	hr_fanb8	
	Circuit B Fan #9 Hours	0	hours	hr_fanb9	
	Circuit B Fan #10 Hours	0	hours	hrfanb10	
	Circuit C Fan #1 Hours	0	hours	hr_fanc1	
	Circuit C Fan #2 Hours	0	hours	hr_fanc2	
	Circuit C Fan #3 Hours	0	hours	hr_fanc3	
	Circuit C Fan #4 Hours	0	hours	hr_fanc4	
	Circuit C Fan #5 Hours	0	hours	hr_fanc5	
	Circuit C Fan #6 Hours	0	hours	hr_fanc6	
	Circuit C Fan #7 Hours	0	hours	hr_fanc7	
	Circuit C Fan #8 Hours	0	hours	hr_fanc8	

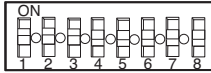
NOTE: This table shall be used for purposes of transplanting the devices run hours in the event of a module hardware failure or software upgrade via downloading. It shall be usable only if all items are still null. Afterwards, its access shall be denied.

TABLE	DISPLAY NAME	RANGE	UNITS	POINT NAME	WRITE STATUS
<b>TABLE TO BE USED FOR RUN TIMES UPDATE IN CASE OF MBB REPLACEMENT</b>					
<b>UPDTHOUR</b>	Machine Operating Hours	0	hours	hr_mach	
	Machine Starts	0		st_mach	
	Compressor A Hours	0	hours	hr_cp_a	
	Compressor A Starts	0		st_cp_a	
	Compressor B Hours	0	hours	hr_cp_b	
	Compressor B Starts	0		st_cp_b	
	Compressor C Hours	0	hours	hr_cp_c	
	Compressor C Starts	0		st_cp_c	
	Water Pump #1 Hours	0	hours	hr_cpum1	
	Water Pump #2 Hours	0	hours	hr_cpum2	
	Condenser Pump #1 Hours	0	hours	hr_hpum1	

NOTE: This table shall be used for purposes of transplanting the devices run hours and starts in the event of a module hardware failure or software upgrade via downloading. It shall be usable only if all items are still null. Afterwards, its access shall be denied.

# APPENDIX D — 30XA080-500 CPM DIP SWITCH ADDRESSES

## ACROSS-THE-LINE START



30XA UNIT SIZE	VOLTAGE (3 ph, 60 Hz)	CPM DIP SWITCHES	CIRCUIT A								CIRCUIT B								CIRCUIT C								MTA SETTING CIRCUIT A	MTA SETTING CIRCUIT B	MTA SETTING CIRCUIT C
			1	2	3	4	5	6	7	8	1	2	3	4	5	6	7	8	1	2	3	4	5	6	7	8			
080, 082	575	S1	OFF	ON	OFF	OFF	OFF	OFF	OFF	OFF	OFF	ON	ON	OFF	OFF	OFF	OFF	OFF	OFF	OFF	OFF	OFF	OFF	OFF	OFF	OFF	70	70	—
		S2	ON	ON	ON	ON	OFF	OFF	OFF	OFF	OFF	ON	ON	ON	ON	OFF	OFF	OFF	OFF	OFF	OFF	OFF	OFF	OFF	OFF	OFF	—	—	—
	460	S1	OFF	ON	OFF	OFF	OFF	OFF	OFF	OFF	OFF	ON	ON	OFF	OFF	OFF	OFF	OFF	OFF	OFF	OFF	OFF	OFF	OFF	OFF	OFF	92	92	—
		S2	OFF	ON	OFF	ON	ON	OFF	OFF	OFF	OFF	OFF	ON	ON	ON	ON	ON	OFF	OFF	OFF	OFF	OFF	OFF	OFF	OFF	OFF	—	—	—
	380	S1	OFF	ON	OFF	ON	OFF	OFF	OFF	OFF	OFF	OFF	ON	OFF	ON	OFF	OFF	OFF	OFF	OFF	OFF	OFF	OFF	OFF	OFF	OFF	106	106	—
		S2	ON	OFF	OFF	OFF	OFF	ON	OFF	OFF	OFF	ON	OFF	OFF	OFF	ON	OFF	ON	OFF	OFF	OFF	OFF	OFF	OFF	OFF	OFF	—	—	—
230	S1	OFF	ON	OFF	ON	OFF	OFF	OFF	OFF	OFF	OFF	ON	OFF	ON	OFF	OFF	ON	OFF	OFF	OFF	OFF	OFF	OFF	OFF	OFF	184	184	—	
	S2	OFF	OFF	OFF	ON	OFF	OFF	ON	OFF	OFF	OFF	OFF	OFF	ON	OFF	OFF	ON	OFF	OFF	ON	OFF	ON	OFF	OFF	OFF	—	—	—	
200	S1	OFF	ON	OFF	ON	OFF	OFF	OFF	OFF	OFF	OFF	ON	OFF	ON	OFF	ON	OFF	OFF	OFF	OFF	OFF	OFF	OFF	OFF	OFF	204	204	—	
	S2	OFF	ON	OFF	OFF	ON	OFF	ON	OFF	OFF	OFF	ON	OFF	OFF	ON	OFF	ON	OFF	ON	OFF	ON	OFF	ON	OFF	OFF	—	—	—	
090, 092	575	S1	OFF	ON	OFF	OFF	OFF	OFF	OFF	OFF	OFF	ON	OFF	OFF	OFF	OFF	OFF	OFF	OFF	OFF	OFF	OFF	OFF	OFF	OFF	OFF	72	72	—
		S2	OFF	OFF	OFF	OFF	ON	OFF	OFF	OFF	OFF	OFF	OFF	OFF	OFF	ON	OFF	OFF	OFF	OFF	OFF	OFF	OFF	OFF	OFF	OFF	—	—	—
	460	S1	OFF	ON	OFF	OFF	OFF	OFF	OFF	OFF	OFF	ON	ON	OFF	ON	ON	OFF	OFF	OFF	OFF	OFF	OFF	OFF	OFF	OFF	OFF	94	94	—
		S2	ON	ON	OFF	ON	ON	OFF	OFF	OFF	OFF	ON	ON	OFF	ON	ON	OFF	ON	OFF	OFF	OFF	OFF	OFF	OFF	OFF	OFF	—	—	—
	380	S1	OFF	ON	OFF	ON	OFF	OFF	OFF	OFF	OFF	OFF	ON	OFF	ON	OFF	ON	OFF	OFF	OFF	OFF	OFF	OFF	OFF	OFF	OFF	110	110	—
		S2	ON	ON	OFF	OFF	OFF	ON	OFF	OFF	OFF	ON	ON	OFF	OFF	OFF	ON	OFF	OFF	ON	OFF	OFF	OFF	OFF	OFF	OFF	—	—	—
230	S1	OFF	ON	OFF	ON	OFF	OFF	OFF	OFF	OFF	OFF	ON	OFF	ON	OFF	ON	OFF	OFF	OFF	OFF	OFF	OFF	OFF	OFF	OFF	190	190	—	
	S2	ON	ON	OFF	ON	OFF	OFF	ON	OFF	OFF	ON	ON	OFF	ON	OFF	OFF	ON	OFF	ON	OFF	ON	OFF	ON	OFF	OFF	—	—	—	
200	S1	OFF	ON	OFF	ON	OFF	OFF	OFF	OFF	OFF	OFF	ON	OFF	ON	OFF	ON	OFF	OFF	OFF	OFF	OFF	OFF	OFF	OFF	OFF	208	208	—	
	S2	OFF	OFF	ON	OFF	ON	OFF	ON	OFF	OFF	OFF	OFF	ON	OFF	ON	OFF	ON	OFF	ON	OFF	ON	OFF	ON	OFF	OFF	—	—	—	
100, 102	575	S1	OFF	ON	OFF	OFF	OFF	OFF	OFF	OFF	OFF	ON	OFF	OFF	OFF	OFF	OFF	OFF	OFF	OFF	OFF	OFF	OFF	OFF	OFF	OFF	80	80	—
		S2	OFF	OFF	ON	OFF	ON	OFF	OFF	OFF	OFF	OFF	OFF	ON	OFF	ON	OFF	ON	OFF	OFF	OFF	OFF	OFF	OFF	OFF	OFF	—	—	—
	460	S1	OFF	ON	OFF	ON	OFF	OFF	OFF	OFF	OFF	OFF	ON	OFF	ON	OFF	ON	OFF	OFF	OFF	OFF	OFF	OFF	OFF	OFF	OFF	104	104	—
		S2	OFF	OFF	OFF	OFF	OFF	ON	OFF	OFF	OFF	OFF	OFF	OFF	OFF	OFF	ON	OFF	OFF	ON	OFF	OFF	OFF	OFF	OFF	OFF	—	—	—
	380	S1	OFF	ON	OFF	ON	OFF	OFF	OFF	OFF	OFF	OFF	ON	OFF	ON	OFF	ON	OFF	OFF	OFF	OFF	OFF	OFF	OFF	OFF	OFF	122	122	—
		S2	ON	OFF	OFF	ON	OFF	ON	OFF	OFF	OFF	ON	OFF	OFF	ON	OFF	ON	OFF	ON	OFF	OFF	OFF	OFF	OFF	OFF	OFF	—	—	—
230	S1	OFF	ON	OFF	ON	OFF	OFF	OFF	OFF	OFF	OFF	ON	OFF	ON	OFF	ON	OFF	OFF	OFF	OFF	OFF	OFF	OFF	OFF	OFF	210	210	—	
	S2	ON	OFF	ON	OFF	ON	OFF	ON	OFF	OFF	ON	OFF	ON	OFF	ON	OFF	ON	OFF	ON	OFF	ON	OFF	ON	OFF	OFF	—	—	—	
200	S1	OFF	ON	OFF	ON	OFF	OFF	OFF	OFF	OFF	OFF	ON	OFF	ON	OFF	ON	OFF	OFF	OFF	OFF	OFF	OFF	OFF	OFF	OFF	232	232	—	
	S2	OFF	OFF	OFF	OFF	OFF	ON	ON	OFF	OFF	OFF	OFF	OFF	OFF	OFF	ON	OFF	ON	OFF	ON	OFF	ON	OFF	OFF	OFF	—	—	—	
110, 112	575	S1	OFF	ON	OFF	OFF	OFF	OFF	OFF	OFF	OFF	ON	OFF	OFF	OFF	OFF	ON	OFF	OFF	OFF	OFF	OFF	OFF	OFF	OFF	OFF	98	80	—
		S2	ON	OFF	ON	ON	ON	OFF	OFF	OFF	OFF	OFF	OFF	ON	OFF	ON	OFF	ON	OFF	OFF	OFF	OFF	OFF	OFF	OFF	OFF	—	—	—
	460	S1	OFF	ON	OFF	ON	OFF	OFF	OFF	OFF	OFF	OFF	ON	OFF	ON	OFF	ON	OFF	OFF	OFF	OFF	OFF	OFF	OFF	OFF	OFF	128	104	—
		S2	OFF	OFF	ON	ON	OFF	ON	OFF	OFF	OFF	OFF	OFF	OFF	OFF	OFF	ON	OFF	OFF	OFF	OFF	OFF	OFF	OFF	OFF	OFF	—	—	—
380	S1	OFF	ON	OFF	ON	OFF	OFF	OFF	OFF	OFF	OFF	ON	OFF	ON	OFF	ON	OFF	OFF	OFF	OFF	OFF	OFF	OFF	OFF	OFF	148	122	—	
	S2	OFF	ON	ON	OFF	ON	ON	OFF	OFF	OFF	ON	OFF	OFF	ON	OFF	ON	OFF	OFF	OFF	OFF	OFF	OFF	OFF	OFF	OFF	—	—	—	
120, 122	575	S1	OFF	ON	OFF	OFF	OFF	OFF	OFF	OFF	OFF	ON	OFF	OFF	OFF	OFF	OFF	OFF	OFF	OFF	OFF	OFF	OFF	OFF	OFF	OFF	98	98	—
		S2	ON	OFF	ON	ON	ON	OFF	OFF	OFF	OFF	ON	OFF	ON	ON	ON	OFF	OFF	OFF	OFF	OFF	OFF	OFF	OFF	OFF	OFF	—	—	—
	460	S1	OFF	ON	OFF	ON	OFF	OFF	OFF	OFF	OFF	OFF	ON	OFF	ON	OFF	ON	OFF	OFF	OFF	OFF	OFF	OFF	OFF	OFF	OFF	128	128	—
		S2	OFF	OFF	ON	ON	OFF	ON	OFF	OFF	OFF	OFF	OFF	ON	ON	OFF	ON	OFF	ON	OFF	OFF	OFF	OFF	OFF	OFF	OFF	—	—	—
380	S1	OFF	ON	OFF	ON	OFF	OFF	OFF	OFF	OFF	OFF	ON	OFF	ON	OFF	ON	OFF	OFF	OFF	OFF	OFF	OFF	OFF	OFF	OFF	148	148	—	
	S2	OFF	ON	ON	OFF	ON	ON	OFF	OFF	OFF	OFF	ON	ON	OFF	ON	ON	OFF	ON	OFF	OFF	OFF	OFF	OFF	OFF	OFF	—	—	—	
140, 142	575	S1	OFF	ON	OFF	ON	OFF	OFF	OFF	OFF	OFF	ON	OFF	OFF	OFF	OFF	ON	OFF	OFF	OFF	OFF	OFF	OFF	OFF	OFF	OFF	152	80	—
		S2	OFF	OFF	OFF	ON	ON	ON	OFF	OFF	OFF	OFF	OFF	ON	OFF	ON	OFF	ON	OFF	OFF	OFF	OFF	OFF	OFF	OFF	OFF	—	—	—
	460	S1	OFF	ON	OFF	ON	OFF	OFF	OFF	OFF	OFF	OFF	ON	OFF	ON	OFF	ON	OFF	OFF	OFF	OFF	OFF	OFF	OFF	OFF	OFF	198	104	—
		S2	ON	ON	ON	ON	ON	OFF	OFF	OFF	OFF	OFF	OFF	OFF	OFF	OFF	ON	OFF	OFF	OFF	OFF	OFF	OFF	OFF	OFF	OFF	—	—	—
380	S1	OFF	ON	OFF	ON	OFF	OFF	OFF	OFF	OFF	OFF	ON	OFF	ON	OFF	ON	OFF	OFF	OFF	OFF	OFF	OFF	OFF	OFF	OFF	230	122	—	
	S2	OFF	ON	ON	ON	ON	OFF	ON	OFF	OFF	ON	OFF	OFF	ON	OFF	ON	OFF	OFF	OFF	OFF	OFF	OFF	OFF	OFF	OFF	—	—	—	
160, 162	575	S1	OFF	ON	OFF	ON	OFF	OFF	OFF	OFF	OFF	ON	OFF	ON	ON	ON	OFF	OFF	OFF	OFF	OFF	OFF	OFF	OFF	OFF	OFF	176	98	—
		S2	OFF	OFF	ON	OFF	OFF	OFF	ON	OFF	OFF	ON	OFF	ON	ON	ON	OFF	OFF	OFF	OFF	OFF	OFF	OFF	OFF	OFF	OFF	—	—	—
	460	S1	OFF	ON	OFF	ON	OFF	OFF	OFF	OFF	OFF	OFF	ON	OFF	ON	OFF	ON	OFF	OFF	OFF	OFF	OFF	OFF	OFF	OFF	OFF	230	128	—
		S2	ON	ON	ON	ON	ON	OFF	ON	OFF	OFF	OFF	OFF	ON	ON	OFF	ON	OFF	ON	OFF	OFF	OFF	OFF	OFF	OFF	OFF	—	—	—
380	S1	OFF	ON	OFF	OFF	ON	OFF	OFF	OFF	OFF	OFF	ON	OFF	ON	OFF	ON	OFF	OFF	OFF	OFF	OFF	OFF	OFF	OFF	OFF	266	148	—	
	S2	OFF	OFF	ON	OFF	OFF	OFF	OFF	OFF	OFF	OFF	ON	ON	OFF	ON	ON	OFF	ON	OFF	OFF	OFF	OFF	OFF	OFF	OFF	—	—	—	
180, 182	575	S1	OFF	ON	OFF	ON	OFF	OFF	OFF	OFF	OFF	OFF	ON	OFF	ON	OFF	ON	OFF	OFF	OFF	OFF	OFF	OFF	OFF	OFF	OFF	152	152	—
		S2	OFF	OFF	OFF	ON	ON	ON	OFF	OFF	OFF	OFF	OFF	OFF	ON	ON	ON	OFF	OFF	OFF	OFF	OFF	OFF	OFF	OFF	OFF	—	—	—
	460	S1	OFF	ON	OFF	ON	OFF	OFF	OFF	OFF	OFF	OFF	ON	OFF	ON	OFF	ON	OFF	OFF	OFF	OFF	OFF	OFF	OFF	OFF	OFF	198	198	—
		S2	ON	ON	ON	ON	OFF	OFF	ON	OFF	OFF	ON	ON	ON	ON	ON	ON	ON	ON	ON	ON	ON	ON	ON	ON	ON	—	—	—
380	S1	OFF	ON	OFF	ON	OFF	OFF	OFF	OFF	OFF	OFF	ON	OFF	ON	OFF	ON	OFF	OFF	OFF	OFF	OFF	OFF	OFF	OFF	OFF	230	230	—	
	S2	ON	ON	ON	ON	ON	ON	ON	ON	ON	ON	ON	ON	ON	ON	ON	ON	ON	ON	ON	ON	ON	ON	ON	ON	ON	—	—	—

**LEGEND**

- CPM — Compressor Protection Module
- MTA — Must Trip Amps



# APPENDIX D — 30XA080-500 CPM DIP SWITCH ADDRESSES (cont)

## WYE DELTA START

30XA UNIT SIZE	VOLTAGE (3 Ph, 60 Hz)	CPM DIP SWITCHES	CIRCUIT A								CIRCUIT B								CIRCUIT C								MTA SETTING CIRCUIT A	MTA SETTING CIRCUIT B	MTA SETTING CIRCUIT C
			1	2	3	4	5	6	7	8	1	2	3	4	5	6	7	8	1	2	3	4	5	6	7	8			
080, 082	575	S1	ON	ON	OFF	OFF	OFF	OFF	OFF	ON	ON	OFF	OFF	OFF	OFF	OFF	OFF	—	—	—	—	—	—	—	—	70	70	—	
		S2	ON	ON	ON	ON	OFF	OFF	OFF	OFF	ON	ON	ON	ON	OFF	OFF	OFF	OFF	—	—	—	—	—	—	—	—	—	—	—
	460	S1	ON	OFF	OFF	OFF	OFF	OFF	OFF	OFF	ON	OFF	OFF	OFF	OFF	OFF	OFF	—	—	—	—	—	—	—	—	92	92	—	
		S2	OFF	ON	OFF	ON	ON	OFF	OFF	OFF	ON	OFF	ON	OFF	ON	ON	OFF	OFF	—	—	—	—	—	—	—	—	—	—	—
	380	S1	ON	OFF	OFF	OFF	OFF	OFF	OFF	OFF	ON	OFF	OFF	OFF	OFF	OFF	OFF	—	—	—	—	—	—	—	—	106	106	—	
		S2	ON	OFF	OFF	OFF	OFF	ON	OFF	OFF	ON	OFF	OFF	OFF	OFF	ON	OFF	OFF	—	—	—	—	—	—	—	—	—	—	—
230	S1	ON	OFF	OFF	ON	ON	OFF	OFF	OFF	ON	OFF	OFF	OFF	OFF	ON	OFF	OFF	—	—	—	—	—	—	—	184	184	—		
	S2	OFF	OFF	OFF	ON	OFF	OFF	ON	OFF	OFF	OFF	OFF	ON	OFF	OFF	ON	OFF	—	—	—	—	—	—	—	—	—	—	—	
200	S1	ON	OFF	OFF	ON	OFF	OFF	OFF	OFF	ON	OFF	OFF	ON	OFF	OFF	ON	OFF	—	—	—	—	—	—	—	204	204	—		
	S2	OFF	ON	OFF	OFF	ON	OFF	ON	OFF	OFF	ON	OFF	OFF	ON	OFF	ON	OFF	—	—	—	—	—	—	—	—	—	—	—	
090, 092	575	S1	ON	ON	OFF	OFF	OFF	OFF	OFF	ON	ON	OFF	OFF	OFF	OFF	OFF	OFF	—	—	—	—	—	—	—	—	72	72	—	
		S2	OFF	OFF	OFF	OFF	OFF	ON	OFF	OFF	OFF	OFF	OFF	OFF	ON	OFF	OFF	—	—	—	—	—	—	—	—	—	—	—	—
	460	S1	ON	ON	OFF	ON	ON	OFF	OFF	OFF	ON	ON	OFF	ON	ON	OFF	OFF	—	—	—	—	—	—	—	—	94	94	—	
		S2	ON	ON	OFF	ON	ON	OFF	OFF	OFF	ON	ON	OFF	ON	ON	OFF	OFF	—	—	—	—	—	—	—	—	—	—	—	—
	380	S1	ON	OFF	OFF	OFF	OFF	OFF	OFF	OFF	ON	OFF	OFF	OFF	OFF	OFF	OFF	—	—	—	—	—	—	—	—	110	110	—	
		S2	ON	ON	OFF	OFF	OFF	ON	OFF	OFF	ON	ON	OFF	OFF	ON	ON	OFF	—	—	—	—	—	—	—	—	—	—	—	—
230	S1	ON	OFF	OFF	ON	OFF	OFF	OFF	OFF	ON	OFF	OFF	ON	OFF	OFF	ON	OFF	—	—	—	—	—	—	—	190	190	—		
	S2	ON	ON	OFF	ON	OFF	OFF	ON	OFF	ON	ON	OFF	ON	OFF	OFF	ON	OFF	—	—	—	—	—	—	—	—	—	—	—	
200	S1	ON	OFF	OFF	ON	OFF	OFF	OFF	OFF	ON	OFF	OFF	ON	OFF	OFF	ON	OFF	—	—	—	—	—	—	—	208	208	—		
	S2	OFF	OFF	ON	OFF	ON	OFF	ON	OFF	OFF	OFF	ON	OFF	ON	OFF	ON	OFF	—	—	—	—	—	—	—	—	—	—	—	
100, 102	575	S1	ON	ON	OFF	OFF	OFF	OFF	OFF	ON	ON	OFF	OFF	OFF	OFF	OFF	OFF	—	—	—	—	—	—	—	—	80	80	—	
		S2	OFF	OFF	ON	OFF	ON	OFF	OFF	OFF	OFF	OFF	ON	OFF	ON	OFF	OFF	—	—	—	—	—	—	—	—	—	—	—	—
	460	S1	ON	OFF	OFF	OFF	OFF	OFF	OFF	OFF	ON	OFF	OFF	OFF	OFF	OFF	OFF	—	—	—	—	—	—	—	—	104	104	—	
		S2	OFF	OFF	OFF	OFF	OFF	ON	OFF	OFF	OFF	OFF	OFF	OFF	ON	OFF	OFF	—	—	—	—	—	—	—	—	—	—	—	—
	380	S1	ON	OFF	OFF	OFF	OFF	OFF	OFF	OFF	ON	OFF	OFF	OFF	OFF	OFF	OFF	—	—	—	—	—	—	—	—	122	122	—	
		S2	ON	OFF	OFF	ON	OFF	ON	OFF	OFF	ON	OFF	OFF	ON	OFF	ON	OFF	—	—	—	—	—	—	—	—	—	—	—	—
230	S1	ON	OFF	OFF	ON	OFF	OFF	OFF	OFF	ON	OFF	OFF	ON	OFF	OFF	ON	OFF	—	—	—	—	—	—	—	210	210	—		
	S2	ON	OFF	ON	OFF	ON	OFF	ON	OFF	ON	OFF	ON	OFF	ON	OFF	ON	OFF	—	—	—	—	—	—	—	—	—	—	—	
200	S1	ON	OFF	OFF	ON	OFF	OFF	OFF	OFF	ON	OFF	OFF	ON	OFF	OFF	ON	OFF	—	—	—	—	—	—	—	232	232	—		
	S2	OFF	OFF	OFF	OFF	OFF	ON	ON	OFF	OFF	OFF	OFF	OFF	ON	ON	OFF	—	—	—	—	—	—	—	—	—	—	—	—	
110, 112	575	S1	ON	ON	OFF	OFF	OFF	OFF	OFF	ON	ON	OFF	OFF	OFF	OFF	OFF	OFF	—	—	—	—	—	—	—	—	98	80	—	
		S2	ON	OFF	ON	ON	ON	OFF	OFF	OFF	OFF	OFF	ON	OFF	ON	OFF	ON	OFF	—	—	—	—	—	—	—	128	104	—	
	460	S1	ON	OFF	OFF	OFF	OFF	OFF	OFF	OFF	ON	OFF	OFF	OFF	OFF	OFF	OFF	—	—	—	—	—	—	—	—	148	122	—	
		S2	OFF	ON	ON	OFF	ON	ON	OFF	OFF	ON	OFF	OFF	ON	OFF	ON	OFF	—	—	—	—	—	—	—	—	—	—	—	—
	380	S1	ON	OFF	OFF	ON	OFF	OFF	OFF	OFF	ON	OFF	OFF	ON	OFF	OFF	OFF	—	—	—	—	—	—	—	—	254	210	—	
		S2	ON	ON	OFF	ON	OFF	ON	ON	OFF	ON	OFF	ON	OFF	ON	OFF	ON	OFF	—	—	—	—	—	—	—	—	—	—	—
230	S1	ON	OFF	OFF	ON	OFF	OFF	OFF	OFF	ON	OFF	OFF	ON	OFF	OFF	ON	OFF	—	—	—	—	—	—	—	282	232	—		
	S2	ON	OFF	OFF	ON	ON	ON	ON	OFF	OFF	OFF	OFF	OFF	ON	ON	OFF	—	—	—	—	—	—	—	—	—	—	—	—	
120, 122	575	S1	ON	ON	OFF	OFF	OFF	OFF	OFF	ON	ON	OFF	OFF	OFF	OFF	OFF	OFF	—	—	—	—	—	—	—	—	98	98	—	
		S2	ON	OFF	ON	ON	ON	OFF	OFF	OFF	ON	OFF	ON	ON	ON	OFF	OFF	—	—	—	—	—	—	—	—	128	128	—	
	460	S1	ON	OFF	OFF	OFF	OFF	OFF	OFF	OFF	ON	OFF	OFF	OFF	OFF	OFF	OFF	—	—	—	—	—	—	—	—	148	148	—	
		S2	OFF	ON	ON	OFF	ON	ON	OFF	OFF	OFF	ON	ON	OFF	ON	ON	OFF	—	—	—	—	—	—	—	—	—	—	—	—
	380	S1	ON	OFF	OFF	ON	OFF	OFF	OFF	OFF	ON	OFF	OFF	OFF	OFF	OFF	OFF	—	—	—	—	—	—	—	—	254	254	—	
		S2	ON	ON	OFF	ON	OFF	ON	ON	OFF	ON	ON	OFF	ON	OFF	ON	ON	OFF	—	—	—	—	—	—	—	—	—	—	—
230	S1	ON	OFF	OFF	ON	OFF	OFF	OFF	OFF	ON	OFF	OFF	ON	OFF	OFF	ON	OFF	—	—	—	—	—	—	—	282	282	—		
	S2	ON	OFF	OFF	ON	ON	ON	ON	OFF	ON	OFF	OFF	ON	ON	ON	ON	OFF	—	—	—	—	—	—	—	—	—	—	—	
140, 142	575	S1	ON	OFF	OFF	OFF	OFF	OFF	OFF	ON	ON	OFF	OFF	OFF	OFF	OFF	OFF	—	—	—	—	—	—	—	—	152	80	—	
		S2	OFF	OFF	OFF	ON	ON	ON	OFF	OFF	OFF	OFF	ON	OFF	ON	OFF	ON	OFF	—	—	—	—	—	—	—	—	—	—	—
	460	S1	ON	OFF	OFF	ON	OFF	OFF	OFF	OFF	ON	OFF	OFF	OFF	OFF	OFF	OFF	—	—	—	—	—	—	—	—	198	104	—	
		S2	ON	ON	ON	ON	OFF	OFF	ON	OFF	OFF	OFF	OFF	OFF	ON	OFF	OFF	—	—	—	—	—	—	—	—	230	122	—	
	380	S1	ON	OFF	OFF	ON	OFF	OFF	OFF	OFF	ON	OFF	OFF	ON	OFF	OFF	OFF	—	—	—	—	—	—	—	—	398	210	—	
		S2	ON	ON	OFF	OFF	ON	ON	OFF	ON	ON	OFF	ON	OFF	ON	OFF	ON	OFF	—	—	—	—	—	—	—	—	—	—	—
230	S1	ON	OFF	OFF	OFF	ON	OFF	OFF	OFF	ON	OFF	OFF	ON	OFF	OFF	ON	OFF	—	—	—	—	—	—	—	438	232	—		
	S2	ON	ON	ON	ON	OFF	ON	OFF	OFF	OFF	OFF	OFF	OFF	OFF	ON	ON	OFF	—	—	—	—	—	—	—	—	—	—	—	
160, 162	575	S1	ON	OFF	OFF	ON	OFF	OFF	OFF	ON	ON	OFF	OFF	OFF	OFF	OFF	OFF	—	—	—	—	—	—	—	—	176	98	—	
		S2	OFF	OFF	ON	OFF	OFF	OFF	ON	OFF	ON	OFF	ON	ON	ON	OFF	OFF	—	—	—	—	—	—	—	—	—	—	—	—
	460	S1	ON	OFF	OFF	ON	OFF	OFF	OFF	OFF	ON	OFF	OFF	OFF	OFF	OFF	OFF	—	—	—	—	—	—	—	—	230	128	—	
		S2	ON	ON	ON	ON	ON	OFF	ON	OFF	OFF	OFF	ON	ON	ON	OFF	ON	OFF	—	—	—	—	—	—	—	—	—	—	—
	380	S1	ON	OFF	OFF	ON	OFF	OFF	OFF	OFF	ON	OFF	OFF	OFF	OFF	OFF	OFF	—	—	—	—	—	—	—	—	266	148	—	
		S2	ON	OFF	OFF	OFF	ON	ON	ON	OFF	OFF	ON	ON	OFF	ON	ON	OFF	—	—	—	—	—	—	—	—	—	—	—	—
230	S1	ON	OFF	OFF	OFF	ON	OFF	OFF	OFF	ON	OFF	OFF	ON	OFF	OFF	OFF	—	—	—	—	—	—	—	—	462	254	—		
	S2	ON	OFF	ON	OFF	ON	ON	OFF	OFF	ON	ON	OFF	ON	OFF	ON	ON	OFF	—	—	—	—	—	—	—	—	—	—	—	
200	S1	ON	OFF	OFF	OFF	ON	OFF	OFF	OFF	ON	OFF	OFF	ON	OFF	OFF	OFF	—	—	—	—	—	—	—	—	506	282	—		
	S2	OFF	OFF	OFF	OFF	OFF	OFF	ON	OFF	ON	OFF	OFF	ON	ON	ON	ON	OFF	—	—	—	—	—	—	—	—	—	—	—	
180, 182	575	S1	ON	OFF	OFF																								



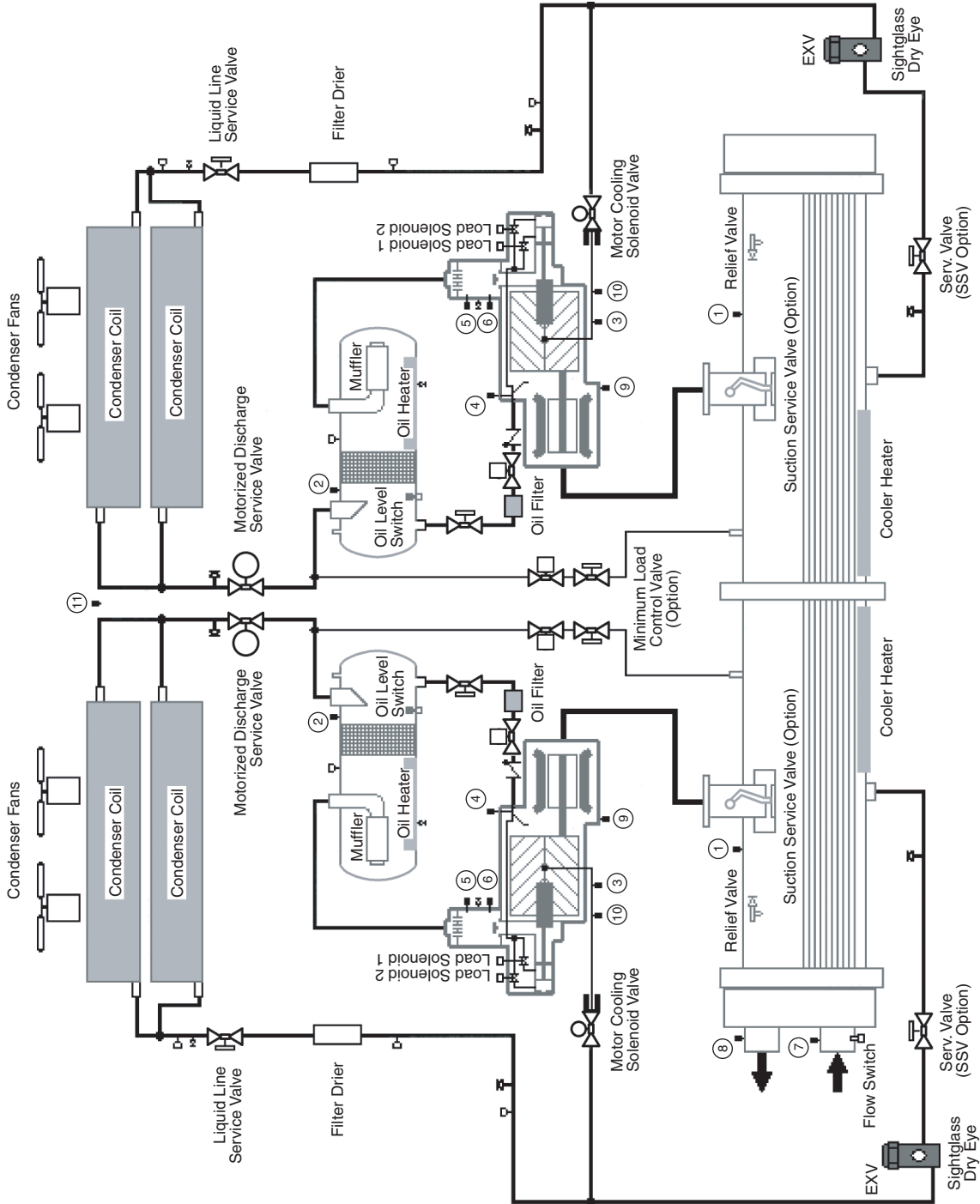


# APPENDIX E — PIPING AND INSTRUMENTATION

## 30XA080 Flooded Cooler Units

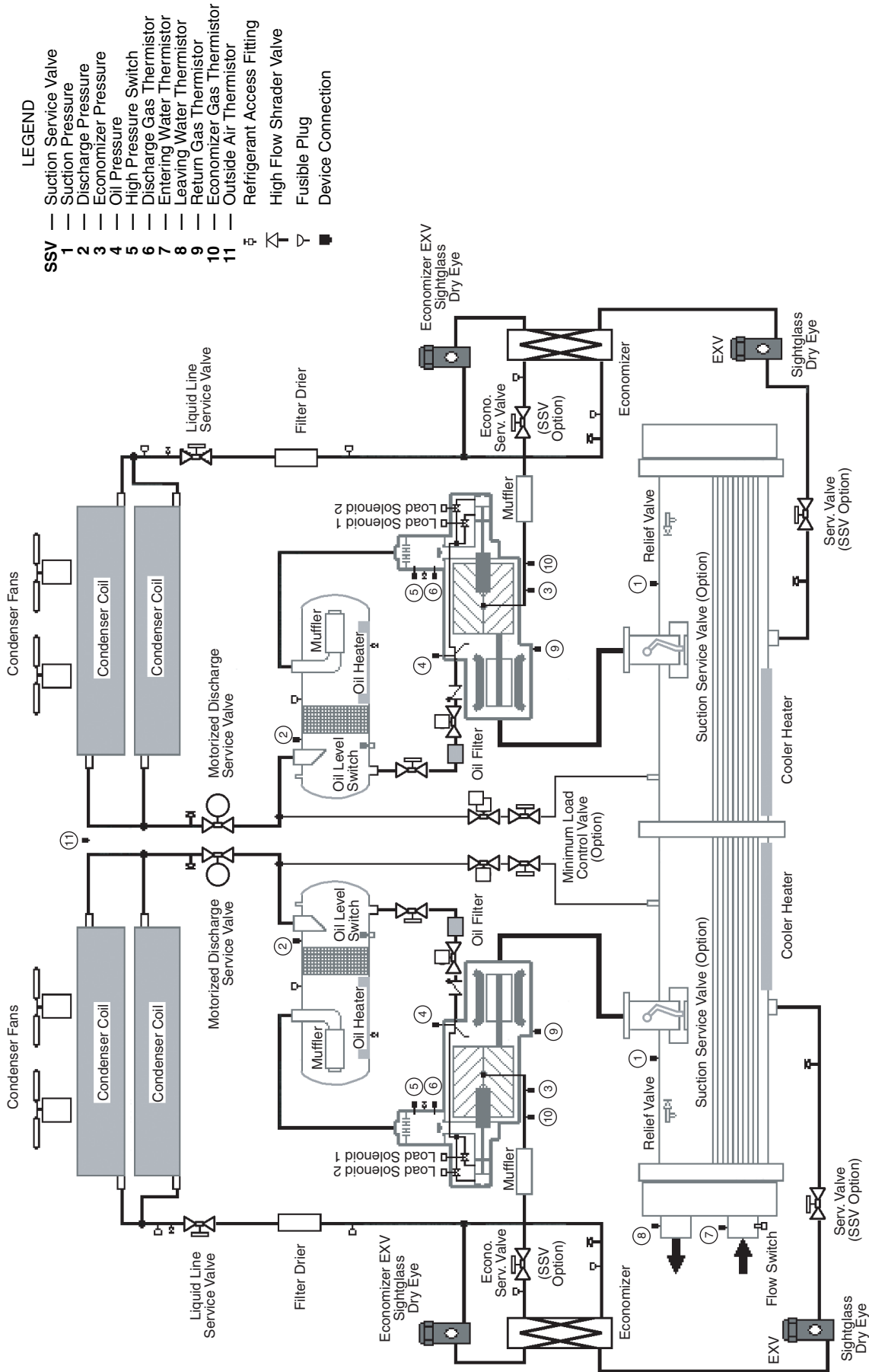
**LEGEND**

—	Suction Service Valve
—	Suction Pressure
—	Discharge Pressure
—	Economizer Pressure
—	Oil Pressure
—	High Pressure Switch
—	Discharge Gas Thermistor
—	Entering Water Thermistor
—	Leaving Water Thermistor
—	Return Gas Thermistor
—	Economizer Gas Thermistor
—	Outside Air Thermistor
⊕	Refrigerant Access Fitting
⊕	High Flow Shrader Valve
⊕	Fusible Plug
⊕	Device Connection



# APPENDIX E — PIPING AND INSTRUMENTATION (cont)

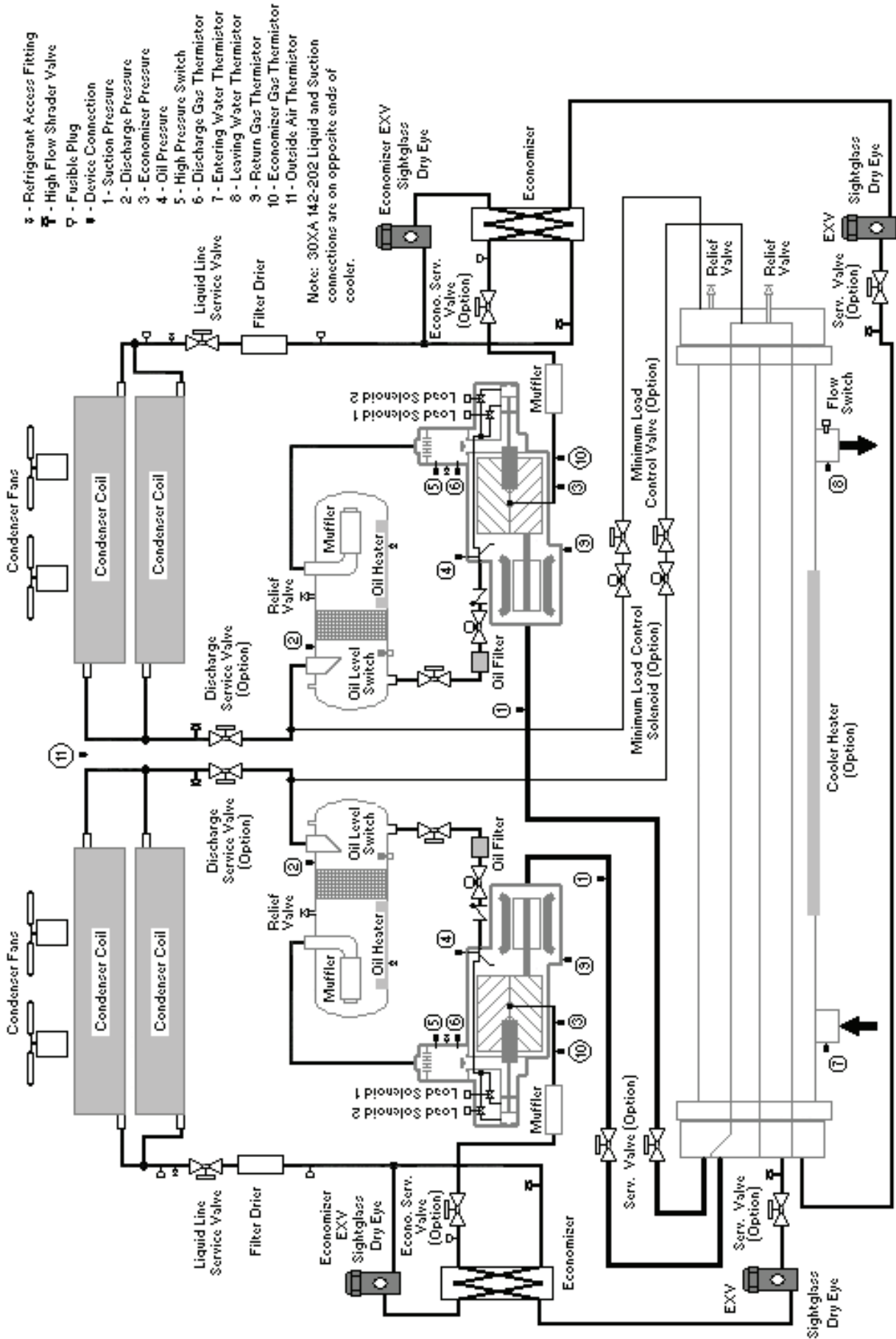
30XA090, 100, 110, 120, 140, 160, 180, 200, 220, 240, 260, 280, 300, 325, 350 Flooded Cooler Units





# APPENDIX E — PIPING AND INSTRUMENTATION (cont)

30XA092, 102, 112, 122, 142, 162, 182, 202, 222, 242, 262, 282, 302, 327, 352 DX Cooler Units



- ⌘ - Refrigerant Access Fitting
- ⌘ - High Flow Strainer Valve
- ⌘ - Fusible Plug
- ⌘ - Device Connection
- 1 - Suction Pressure
- 2 - Discharge Pressure
- 3 - Economizer Pressure
- 4 - Oil Pressure
- 5 - High Pressure Switch
- 6 - Discharge Gas Thermistor
- 7 - Entering Water Thermistor
- 8 - Leaving Water Thermistor
- 9 - Return Gas Thermistor
- 10 - Economizer Gas Thermistor
- 11 - Outside Air Thermistor

Note: 30XA 142-202 Liquid and Suction connections are on opposite ends of cooler.

**APPENDIX F — MAINTENANCE SUMMARY AND LOG SHEETS**  
**30XA Maintenance Interval Requirements**

<b>WEEKLY</b>			
<b>Compressor</b>	Check Oil Level.	<b>Economizer</b>	None.
<b>Cooler</b>	None.	<b>Controls</b>	Review Alarm/Alert History.
<b>Condenser</b>	Inspect and clean all coils as necessary.	<b>Starter</b>	None.
<b>MONTHLY</b>			
<b>Compressor</b>	Check Oil Level.	<b>Economizer</b>	None.
<b>Cooler</b>	Check moisture.	<b>Controls</b>	Check accuracy of transducers and thermistors. Verify flow switch operation.
<b>Condenser</b>	Inspect and clean all coils as necessary.	<b>Starter</b>	Inspect all contactors.
<b>QUARTERLY</b>			
<b>Compressor</b>	Check Oil Level	<b>Economizer</b>	Check all connections for leaks.
<b>Cooler</b>	Check refrigerant charge. Check for leaks.	<b>Controls</b>	Perform an Automated Controls test. Run all Compressors and ensure proper operation. Verify operation of units flow switch.
<b>Condenser</b>	Check for leaks.	<b>Starter</b>	None.
<b>ANNUALLY</b>			
<b>Compressor</b>	Check Oil Level. Obtain and test an oil sample.	<b>Economizer</b>	Verify proper operation of EXVs.
<b>Cooler</b>	Check approach on unit to determine if tubes need cleaning (flooded cooler units only). Check for temperature drop across filter drier to determine if filter needs replacement.	<b>Controls</b>	Perform an Automated Controls test. Run all Compressors and ensure proper operation.
<b>Condenser</b>	Check fan blades and motors for cracks and loose bolts. Tighten bolts as needed.	<b>Starter</b>	Inspect all electrical connections and tighten as needed. Measure current to each compressor and inspect contactors.

NOTE: Equipment failures caused by lack of adherence to the Maintenance Interval Requirements are not covered under warranty.

**APPENDIX F — MAINTENANCE SUMMARY AND LOG SHEETS (cont)**

**30XA Monthly Maintenance Log**

<b>Month</b>			<b>1</b>	<b>2</b>	<b>3</b>	<b>4</b>	<b>5</b>	<b>6</b>	<b>7</b>	<b>8</b>	<b>9</b>	<b>10</b>	<b>11</b>	<b>12</b>
<b>Date</b>			/ /	/ /	/ /	/ /	/ /	/ /	/ /	/ /	/ /	/ /	/ /	/ /
<b>Operator</b>														

<b>UNIT SECTION</b>	<b>ACTION</b>	<b>UNIT</b>	<b>ENTRY</b>											
<b>Compressor</b>	Change Oil Filter (Screw Compressors)	yes/no	Year 1 then As Needed											
	Send Oil Sample Out for Analysis	yes/no	Annually											
	Leak Test	yes/no												
<b>Cooler</b>	Inspect and Clean Cooler Tubes*	yes/no	Every 3 - 5 Years											
	Inspect Cooler Heater	amps												
	Inspect Relief Valves	yes/no												
	Leak Test	yes/no												
	Record Water Pressure Differential (PSI)	PSI												
	Inspect Water Pumps	yes/no												
	Eddy Current Test	yes/no	Every 3 - 5 Years											
<b>Condenser</b>	Leak Test	yes/no												
	Inspect and Clean Condenser Coils	yes/no												
	Inspect Relief Valves	yes/no												
<b>Controls</b>	General Cleaning and Tightening Connections	yes/no	Annually											
	Check Pressure Transducers for Accuracy	yes/no												
	Verify Flow Switch Operation	yes/no												
	Confirm Accuracy of Thermistors	yes/no												
<b>Starter</b>	General Tightening and Cleaning Connections	yes/no	Annually											
	Inspect All Contactors	yes/no												
<b>System</b>	Check Refrigerant Charge	yes/no												
	Verify Operation of EXVs	yes/no												
	Record System Superheat	deg. F												

166

\*Flooded cooler units only.

NOTE: Equipment failures caused by lack of adherence to the Maintenance Interval Requirements are not covered under warranty.

**APPENDIX F — MAINTENANCE SUMMARY AND LOG SHEETS (cont)**  
**30XA Seasonal Shutdown Log**

<b>Month</b>		<b>1</b>	<b>2</b>	<b>3</b>	<b>4</b>	<b>5</b>	<b>6</b>	<b>7</b>	<b>8</b>	<b>9</b>	<b>10</b>	<b>11</b>	<b>12</b>
<b>Date</b>		/ /	/ /	/ /	/ /	/ /	/ /	/ /	/ /	/ /	/ /	/ /	/ /
<b>Operator</b>													

<b>UNIT SECTION</b>	<b>ACTION</b>	<b>ENTRY</b>												
<b>Cooler</b>	Isolate and Drain Waterbox/Cooler													
	Add Glycol/Water Mixture To Prevent Freeze-up													
<b>Controls</b>	Do Not Disconnect Control Power													

NOTE: Equipment failures caused by lack of adherence to the Maintenance Interval Requirements are not covered under warranty.

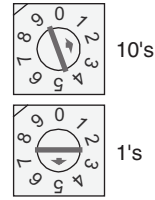
## APPENDIX G — BACNET COMMUNICATIONS OPTION

The following section is used to configure the UPC Open controller which is used when the BACnet\* communications option is selected. The UPC Open controller is mounted in a separate enclosure below the main control box.

**TO ADDRESS THE UPC OPEN CONTROLLER** — The user must give the UPC Open controller an address that is unique on the BACnet network. Perform the following procedure to assign an address:

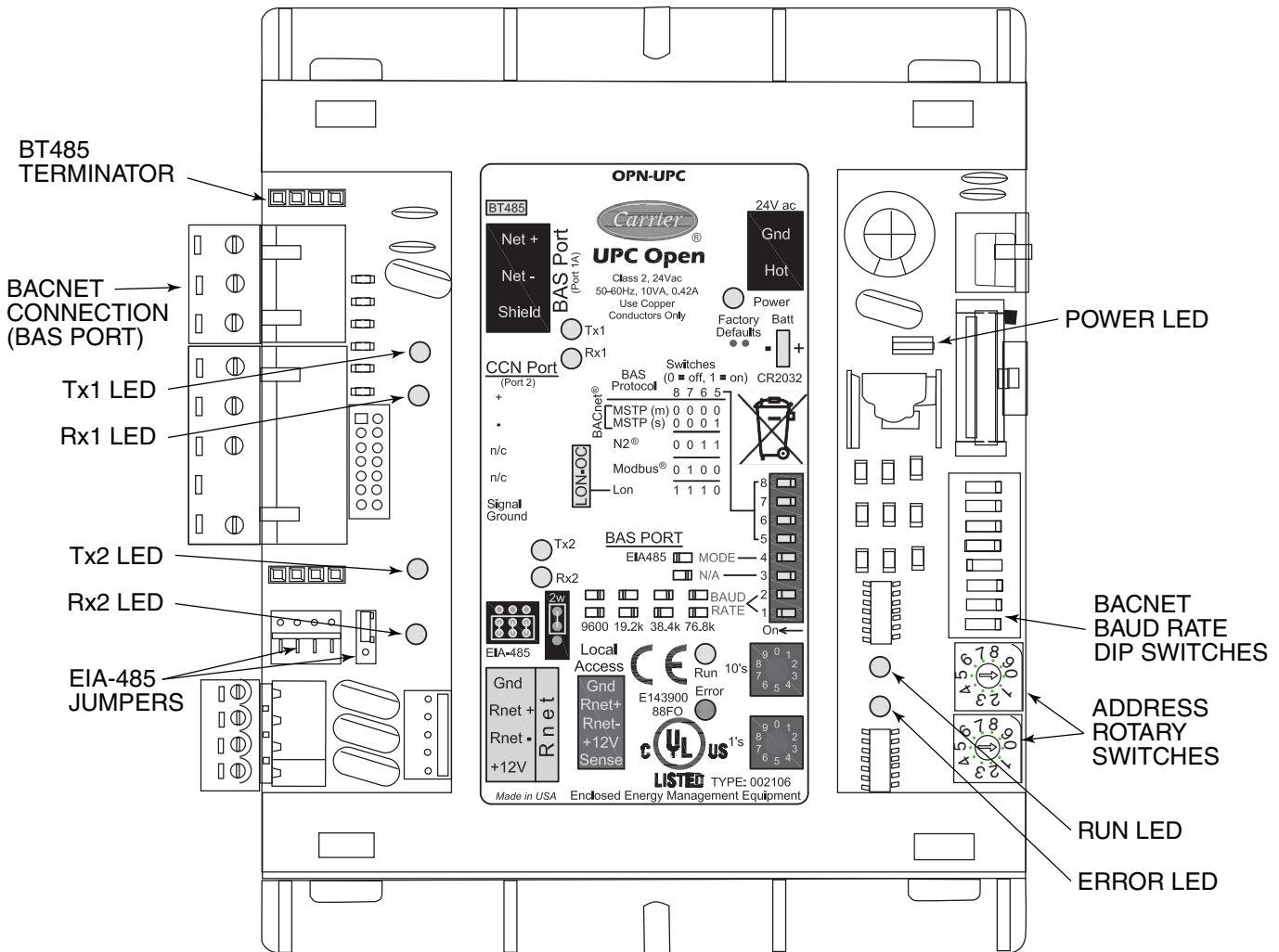
1. If the UPC Open controller is powered, pull the screw terminal connector from the controller's power terminals labeled Gnd and HOT. The controller reads the address each time power is applied to it.
2. Using the rotary switches (see Fig. A and B), set the controller's address. Set the Tens (10's) switch to the tens digit of the address, and set the Ones (1's) switch to the ones digit.

As an example in Fig. B, if the controller's address is 25, point the arrow on the Tens (10's) switch to 2 and the arrow on the Ones (1's) switch to 5.



**Fig. B — Address Rotary Switches**

**BACNET DEVICE INSTANCE ADDRESS** — The UPC Open controller also has a BACnet Device Instance address. This Device Instance **MUST** be unique for the complete BACnet system in which the UPC Open controller is installed. The Device Instance is auto generated by default and is derived by adding the MAC address to the end of the Network Number. The Network Number of a new UPC Open controller is 16101, but it can be changed using i-Vu® Tools or BACView device. By default, a MAC address of 20 will result in a Device Instance of 16101 + 20 which would be a Device Instance of 1610120.



**Fig. A — UPC Open Controller**

\*Sponsored by ASHRAE (American Society of Heating, Refrigerating, and Air Conditioning Engineers).



## APPENDIX G — BACNET COMMUNICATIONS OPTION (cont)

CONFIGURING THE BAS PORT FOR BACNET MS/TP — Use the same baud rate and communication settings for all controllers on the network segment. The UPC Open controller is fixed at 8 data bits, No Parity, and 1 Stop bit for this protocol's communications.

If the UPC Open controller has been wired for power, pull the screw terminal connector from the controller's power terminals labeled Gnd and HOT. The controller reads the DIP Switches and jumpers each time power is applied to it.

Set the BAS Port DIP switch DS3 to “enable.” Set the BAS Port DIP switch DS4 to “E1-485.” Set the BMS Protocol DIP switches DS8 through DS5 to “MSTP.” See Table A.

**Table A — SW3 Protocol Switch Settings for MS/TP**

DS8	DS7	DS6	DS5	DS4	DS3
Off	Off	Off	Off	On	Off

Verify that the EIA-485 jumpers below the CCN Port are set to EIA-485 and 2W.

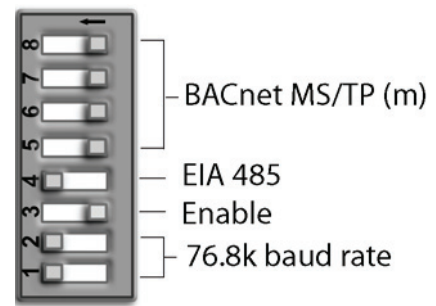
The example in Fig. C shows the BAS Port DIP Switches set for 76.8k (Carrier default) and MS/TP.

Set the BAS Port DIP Switches DS2 and DS1 for the appropriate communications speed of the MS/TP network (9600, 19.2k, 38.4k, or 76.8k bps). See Fig. C and Table B.

**Table B — Baud Selection Table**

BAUD RATE	DS2	DS1
9,600	Off	Off
19,200	On	Off
38,400	Off	On
76,800	On	On

WIRING THE UPC OPEN CONTROLLER TO THE MS/TP NETWORK — The UPC Open controller communicates using BACnet on an MS/TP network segment communications at 9600 bps, 19.2 kbps, 38.4 kbps, or 76.8 kbps.



**Fig. C — DIP Switches**

Wire the controllers on an MS/TP network segment in a daisy-chain configuration. Wire specifications for the cable are 22 AWG (American Wire Gage) or 24 AWG, low-capacitance, twisted, stranded, shielded copper wire. The maximum length is 2000 ft.

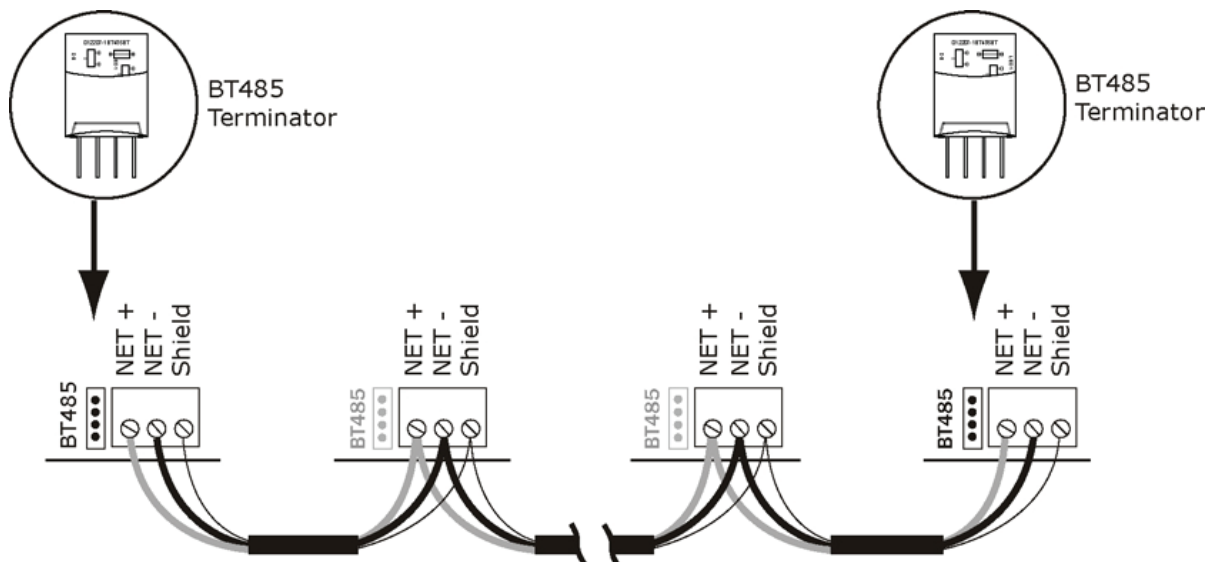
Install a BT485 terminator on the first and last controller on a network segment to add bias and prevent signal distortions due to echoing. See Fig. A, D, and E.

To wire the UPC Open controller to the BAS network:

1. Pull the screw terminal connector from the controller's BAS Port.
2. Check the communications wiring for shorts and grounds.
3. Connect the communications wiring to the BAS port's screw terminals labeled Net +, Net -, and Shield.

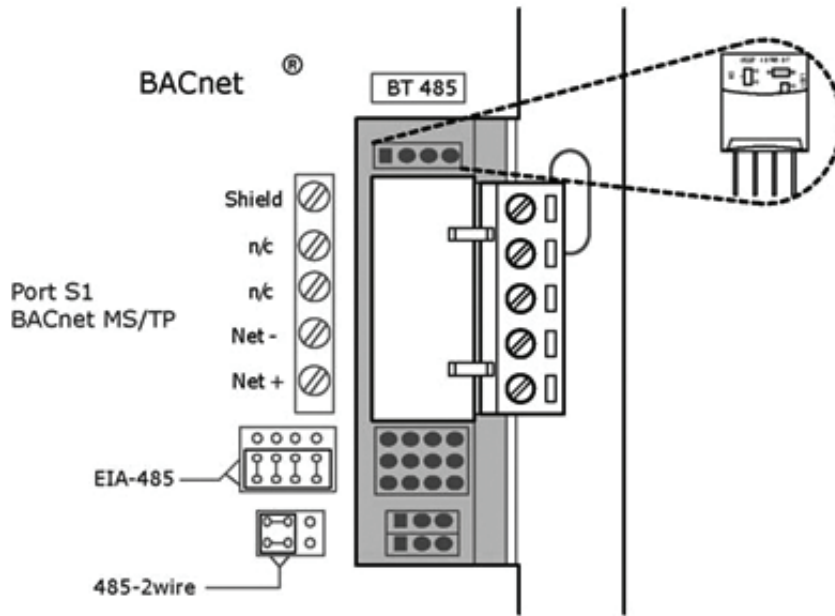
NOTE: Use the same polarity throughout the network segment.

4. Insert the power screw terminal connector into the UPC Open controller's power terminals if they are not currently connected.
5. Verify communication with the network by viewing a module status report. To perform a module status report using the BACview keypad/display unit, press and hold the “FN” key then press the “.” Key.



**Fig. D — Network Wiring**

## APPENDIX G — BACNET COMMUNICATIONS OPTION (cont)



**Fig. E — BT485 Terminator Installation**

To install a BT485 terminator, push the BT485 terminator on to the BT485 connector located near the BACnet connector.

NOTE: The BT485 terminator has no polarity associated with it.

To order a BT485 terminator, consult Commercial Products i-Vu Open Control System Master Prices.

MS/TP WIRING RECOMMENDATIONS — Recommendations are shown in Tables C and D. The wire jacket and UL

temperature rating specifications list two acceptable alternatives. The Halar specification has a higher temperature rating and a tougher outer jacket than the SmokeGard specification, and it is appropriate for use in applications where the user is concerned about abrasion. The Halar jacket is also less likely to crack in extremely low temperatures.

NOTE: Use the specified type of wire and cable for maximum signal integrity.

**Table C — MS/TP Wiring Recommendations**

SPECIFICATION	RECOMMENDATION
<b>Cable</b>	Single twisted pair, low capacitance, CL2P, 22 AWG (7x30), TC foam FEP, plenum rated cable
<b>Conductor</b>	22 or 24 AWG stranded copper (tin plated)
<b>Insulation</b>	Foamed FEP 0.015 in. (0.381 mm) wall 0.060 in. (1.524 mm) O.D.
<b>Color Code</b>	Black/White
<b>Twist Lay</b>	2 in. (50.8 mm) lay on pair 6 twists/foot (20 twists/meter) nominal
<b>Shielding</b>	Aluminum/Mylar shield with 24 AWG TC drain wire
<b>Jacket</b>	SmokeGard Jacket (SmokeGard PVC) 0.021 in. (0.5334 mm) wall 0.175 in. (4.445 mm) O.D. Halar Jacket (E-CTFE) 0.010 in. (0.254 mm) wall 0.144 in. (3.6576 mm) O.D.
<b>DC Resistance</b>	15.2 Ohms/1000 feet (50 Ohms/km) nominal
<b>Capacitance</b>	12.5 pF/ft (41 pF/meter) nominal conductor to conductor
<b>Characteristic Impedance</b>	100 Ohms nominal
<b>Weight</b>	12 lb/1000 feet (17.9 kg/km)
<b>UL Temperature Rating</b>	SmokeGard 167°F (75°C) Halar -40 to 302°F (-40 to 150°C)
<b>Voltage</b>	300 Vac, power limited
<b>Listing</b>	UL: NEC CL2P, or better

### LEGEND

<b>AWG</b>	— American Wire Gage
<b>CL2P</b>	— Class 2 Plenum Cable
<b>DC</b>	— Direct Current
<b>FEP</b>	— Fluorinated Ethylene Polymer
<b>NEC</b>	— National Electrical Code
<b>O.D.</b>	— Outside Diameter
<b>TC</b>	— Tinned Copper
<b>UL</b>	— Underwriters Laboratories

## APPENDIX G — BACNET COMMUNICATIONS OPTION (cont)

**Table D — Open System Wiring Specifications and Recommended Vendors**

WIRING SPECIFICATIONS		RECOMMENDED VENDORS AND PART NUMBERS			
Wire Type	Description	Connect Air International	Belden	RMCORP	Contractors Wire and Cable
<b>MS/TP Network (RS-485)</b>	22 AWG, single twisted shielded pair, low capacitance, CL2P, TC foam FEP, plenum rated. See MS/TP Installation Guide for specifications.	W221P-22227	—	25160PV	CLP0520LC
	24 AWG, single twisted shielded pair, low capacitance, CL2P, TC foam FEP, plenum rated. See MS/TP Installation Guide for specifications.	W241P-2000F	82841	25120-OR	—
<b>Rnet</b>	4 conductor, unshielded, CMP, 18 AWG, plenum rated.	W184C-2099BLB	6302UE	21450	CLP0442

**LEGEND**

- AWG** — American Wire Gage
- CL2P** — Class 2 Plenum Cable
- CMP** — Communications Plenum Rated
- FEP** — Fluorinated Ethylene Polymer
- TC** — Tinned Copper

**LOCAL ACCESS TO THE UPC OPEN CONTROLLER** — The user can use a BACview<sup>6</sup> handheld keypad display unit or the Virtual BACview software as a local user interface to an Open controller. These items let the user access the controller network information. These are accessory items and do not come with the UPC Open controller.

The BACview<sup>6</sup> unit connects to the local access port on the UPC Open controller. See Fig. F. The BACview software must be running on a laptop computer that is connected to the local access port on the UPC Open controller. The laptop will require an additional USB link cable for connection.

See the *BACview Installation and User Guide* for instructions on connecting and using the BACview<sup>6</sup> device.

To order a BACview<sup>6</sup> Handheld (BV6H), consult Commercial Products i-Vu<sup>®</sup> Open Control System Master Prices.

**CONFIGURING THE UPC OPEN CONTROLLER'S PROPERTIES** — The UPC Open device and *ComfortLink* control must be set to the same CCN Address (Element)

number and CCN Bus number. The factory default settings for CCN Element and CCN Bus number are 1 and 0 respectively.

If modifications to the default Element and Bus number are required, both the *ComfortLink*<sup>™</sup> and UPC Open configurations must be changed.

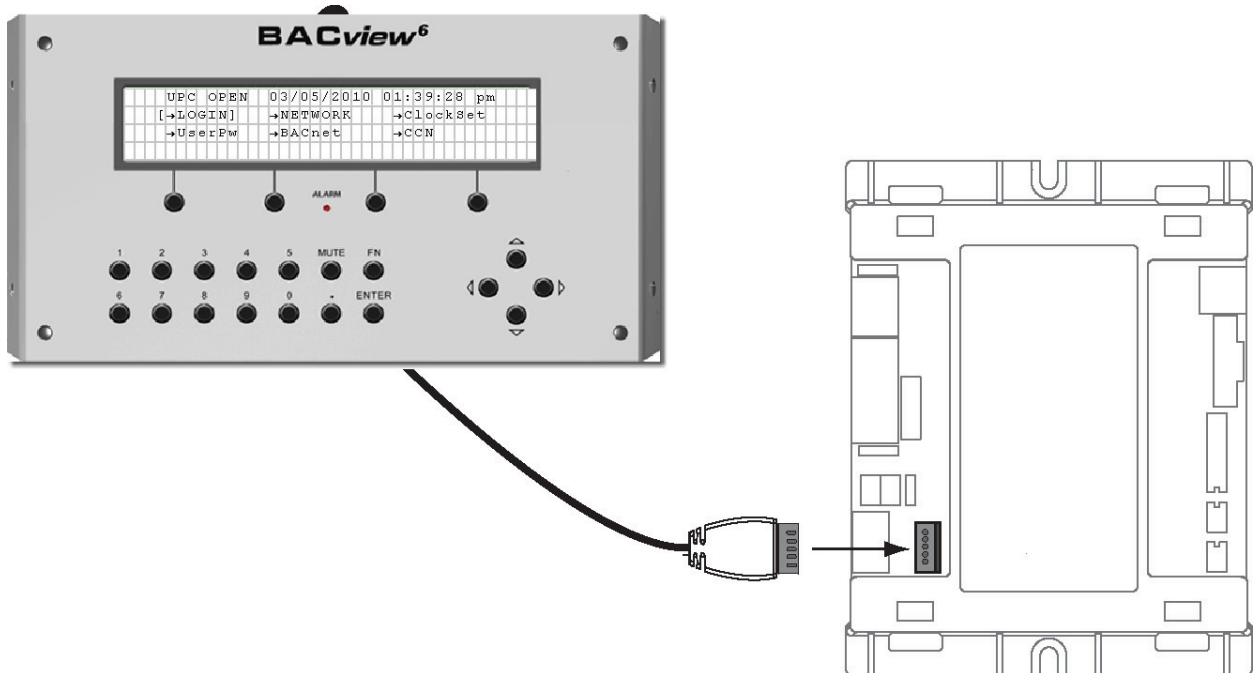
The following configurations are used to set the CCN Address and Bus number in the *ComfortLink* control. These configurations can be changed using the scrolling marquee display or accessory Navigator<sup>™</sup> handheld device.

**Configuration** → **CCN** → **CCN.A** (CCN Address)

**Configuration** → **CCN** → **CCN.B** (CCN Bus Number)

The following configurations are used to set the CCN Address and Bus Number in the UPC Open controller. These configurations can be changed using the accessory BACview<sup>6</sup> display.

Navigation: BACview → CCN  
 Home: Element Comm Stat  
 Element: 1  
 Bus: 0



**Fig. F — BACview<sup>6</sup> Device Connection**

## APPENDIX G — BACNET COMMUNICATIONS OPTION (cont)

If the UPC Open controller is used with the chiller application of Lead/Lag/Standby, all chillers and UPC Open's CCN element numbers must be changed to a unique number in order to follow CCN specifications. In this application, there can only be a maximum of 3 UPC Open controllers on a CCN bus.

For the CCN Alarm Acknowledger configuration, the UPC Open controller defaults to CCN Acknowledger. If a Chiller Lead/Lag/Standby application is being used, then the Carrier technician must change the configuration to only one CCN Acknowledger on the CCN bus.

For the CCN Time Broadcaster configuration, the UPC Open controller defaults to CCN Time Broadcaster. If the Chiller Lead/Lag/Standby application is used, then the Carrier technician must change the configuration to only one CCN Time Broadcaster on the CCN bus.

**TROUBLESHOOTING** — If there are problems wiring or addressing the UPC Open controller, contact Carrier Technical Support.

**COMMUNICATION LEDS** — The LEDs indicate if the controller is communicating with the devices on the network.

See Tables E and F. The LEDs should reflect communication traffic based on the baud rate set. The higher the baud rate the more solid the LEDs become. See Fig. A for location of LEDs on UPC Open module.

**REPLACING THE UPC OPEN BATTERY** — The UPC Open controller's 10-year lithium CR2032 battery provides a minimum of 10,000 hours of data retention during power outages.

**IMPORTANT:** Power must be **ON** to the UPC Open controller when replacing the battery, or the date, time, and trend data will be lost.

Remove the battery from the controller, making note of the battery's polarity. Insert the new battery, matching the battery's polarity with the polarity indicated on the UPC Open controller.

**NETWORK POINTS LIST** — The points list for the controller is shown in Table G.

**Table E — LED Status Indicators**

LED	STATUS
<b>Power</b>	Lights when power is being supplied to the controller. The UPC Open controller is protected by internal solid-state polyswitches on the incoming power and network connections. These polyswitches are not replaceable and will reset themselves if the condition that caused the fault returns to normal.
<b>Rx</b>	Lights when the controller receives data from the network segment; there is an Rx LED for Ports 1 and 2.
<b>Tx</b>	Lights when the controller transmits data to the network segment; there is an Tx LED for Ports 1 and 2.
<b>Run</b>	Lights based on controller status. See Table F.
<b>Error</b>	Lights based on controller status. See Table F.

**Table F — Run and Error LEDs Controller and Network Status Indication**

RUN LED	ERROR LED	STATUS
2 flashes per second	Off	Normal
2 flashes per second	2 flashes, alternating with Run LED	Five minute auto-restart delay after system error
2 flashes per second	3 flashes, then off	Controller has just been formatted
2 flashes per second	1 flash per second	Controller is alone on the network
2 flashes per second	On	Exec halted after frequent system errors or control programs halted
5 flashes per second	On	Exec start-up aborted, Boot is running
5 flashes per second	Off	Firmware transfer in progress, Boot is running
7 flashes per second	7 flashes per second, alternating with Run LED	Ten second recovery period after brownout
14 flashes per second	14 flashes per second, alternating with Run LED	Brownout

## APPENDIX G — BACNET COMMUNICATIONS OPTION (cont)

### Table G — Network Points List

BACNET OBJECT ID	POINT NAME	READ/ WRITE	UNITS	DEFAULT VALUE	RANGE	BACNET OBJECT NAME
AV:1	Circuit A Fan #1 Hours	R	hr			hr_fana1_1
AV:2	Circuit A Fan #2 Hours	R	hr			hr_fana2_1
AV:3	Circuit A Fan #3 Hours	R	hr			hr_fana3_1
AV:4	Circuit A Fan #4 Hours	R	hr			hr_fana4_1
AV:5	Circuit A Fan #5 Hours	R	hr			hr_fana5_1
AV:6	Circuit A Fan #6 Hours	R	hr			hr_fana6_1
AV:7	Circuit A Fan #7 Hours	R	hr			hr_fana7_1
AV:8	Circuit A Fan #8 Hours	R	hr			hr_fana8_1
AV:9	Circuit A Fan #9 Hours	R	hr			hr_fana9_1
AV:10	Circuit A Fan #10 Hours	R	hr			hrfana10_1
AV:11	Circuit B Fan #1 Hours	R	hr			hr_fanb1_1
AV:12	Circuit B Fan #2 Hours	R	hr			hr_fanb2_1
AV:13	Circuit B Fan #3 Hours	R	hr			hr_fanb3_1
AV:14	Circuit B Fan #4 Hours	R	hr			hr_fanb4_1
AV:15	Circuit B Fan #5 Hours	R	hr			hr_fanb5_1
AV:16	Circuit B Fan #6 Hours	R	hr			hr_fanb6_1
AV:17	Circuit B Fan #7 Hours	R	hr			hr_fanb7_1
AV:18	Circuit B Fan #8 Hours	R	hr			hr_fanb8_1
AV:19	Circuit B Fan #9 Hours	R	hr			hr_fanb9_1
AV:20	Circuit B Fan #10 Hours	R	hr			hrfanb10_1
AV:21	Circuit C Fan #1 Hours	R	hr			hr_fanc1_1
AV:22	Circuit C Fan #2 Hours	R	hr			hr_fanc2_1
AV:23	Circuit C Fan #3 Hours	R	hr			hr_fanc3_1
AV:24	Circuit C Fan #4 Hours	R	hr			hr_fanc4_1
AV:25	Circuit C Fan #5 Hours	R	hr			hr_fanc5_1
AV:26	Circuit C Fan #6 Hours	R	hr			hr_fanc6_1
AV:27	Circuit C Fan #7 Hours	R	hr			hr_fanc7_1
AV:28	Circuit C Fan #8 Hours	R	hr			hr_fanc8_1
AV:29	Compressor Suction Temp	R	°F			suct_t_a_1
AV:30	Compressor Suction Temp	R	°F			suct_t_b_1
AV:31	Compressor Suction Temp	R	°F			suct_t_c_1
AV:32	Discharge Gas Temp	R	°F			dgt_a_1
AV:33	Discharge Gas Temp	R	°F			dgt_b_1
AV:34	Discharge Gas Temp	R	°F			dgt_c_1
AV:35	Discharge Pressure	R	psi			dp_a_1
AV:36	Discharge Pressure	R	psi			dp_b_1
AV:37	Discharge Pressure	R	psi			dp_c_1
AV:38	Economizer Gas Temp	R	°F			eco_tp_a_1
AV:39	Economizer Gas Temp	R	°F			eco_tp_b_1
AV:40	Economizer Gas Temp	R	°F			eco_tp_c_1
AV:41	Economizer Pressure	R	psi			econ_p_a_1
AV:42	Economizer Pressure	R	psi			econ_p_b_1
AV:43	Economizer Pressure	R	psi			econ_p_c_1
AV:44	EXV Position	R	%			exv_a_1
AV:45	EXV Position	R	%			exv_b_1
AV:46	EXV Position	R	%			exv_c_1
AV:47	Fan Staging Number	R				fan_st_a_1
AV:48	Fan Staging Number	R				fan_st_b_1
AV:49	Fan Staging Number	R				fan_st_c_1
AV:50	Head Pressure Actuator Position	R	%			hd_pos_a_1
AV:51	Head Pressure Actuator Position	R	%			hd_pos_b_1
AV:52	Head Pressure Actuator Position	R	%			hd_pos_c_1
AV:53	Heat/Cool Select	R/W			0=Cool 1=Heat 2=Auto	hc_sel_1
AV:54	Minutes Left for Start	R	min			min_left_1

#### LEGEND

<b>CHWS</b> — Chilled Water Switch	<b>EXV</b> — Expansion Valve
<b>DGT</b> — Discharge Gas Thermistor	<b>OAT</b> — Outdoor Air Temperature
<b>DO</b> — Digital Output	<b>R</b> — Read
<b>EWT</b> — Entering Water Temperature	<b>W</b> — Write

**APPENDIX G — BACNET COMMUNICATIONS OPTION (cont)**

**Table G — Network Points List (cont)**

BACNET OBJECT ID	POINT NAME	READ/WRITE	UNITS	DEFAULT VALUE	RANGE	BACNET OBJECT NAME
AV:55	Motor Current	R	A			curren_a_1
AV:56	Motor Current	R	A			curren_b_1
AV:57	Motor Current	R	A			curren_c_1
AV:58	Motor Temperature	R	°F			cp_tmp_a_1
AV:59	Motor Temperature	R	°F			cp_tmp_b_1
AV:60	Motor Temperature	R	°F			cp_tmp_c_1
AV:61	Oil Pressure	R	psi			op_a_1
AV:62	Oil Pressure	R	psi			op_b_1
AV:63	Oil Pressure	R	psi			op_c_1
AV:64	Oil Pressure Difference	R	psi			dop_a_1
AV:65	Oil Pressure Difference	R	psi			dop_b_1
AV:67	Percent Total Capacity	R	%			capa_t_1
AV:68	Percent Total Capacity	R	%			capb_t_1
AV:69	Percent Total Capacity	R	%			capc_t_1
AV:70	Saturated Condensing Temp	R	°F			sct_a_1
AV:71	Saturated Condensing Temp	R	°F			sct_b_1
AV:72	Saturated Condensing Temp	R	°F			sct_c_1
AV:73	Saturated Suction Temp	R	°F			sst_a_1
AV:74	Saturated Suction Temp	R	°F			sst_b_1
AV:75	Saturated Suction Temp	R	°F			sst_c_1
AV:76	Suction Pressure	R	psi			sp_a_1
AV:77	Suction Pressure	R	psi			sp_b_1
AV:78	Suction Pressure	R	psi			sp_c_1
AV:79	Active Demand Limit Value	R/W	%		0-100	dem_lim_1
AV:80	Actual Chiller Current	R	A			tot_curr_1
AV:81	Chiller Current Limit	R/W	A		0 - 4000	curr_lim_1
AV:82	Controlled Water temp	R	°F			ctrl_wt_1
AV:83	Control point	R/W	°F		0 - 100	ctrl_pnt_1
AV:84	Current Setpoint	R	°F			sp_1
AV:85	External Temperature	R	°F			oat_1
AV:86	Lag Capacity Limit Value	R	%			lag_lim_1
AV:87	Percent Total Capacity	R	%			cap_t_1
AV:88	Setpoint Select	R				sp_sel_1
AV:89	Chiller Capacity Signal	R	V			capt_010_1
AV:90	CHWS Temperature	R	°F			chwstemp_1
AV:91	Circuit C Heater Temp	R	°F			t_heat_c_1
AV:92	Heat/Cool Status	R				heatcool_1
AV:93	Run Status	R			0=Off 1=Running 2=Stopping 3= Delay 4=Tripout 5=Ready 6=Override 7=Defrost 8=Run Test 9=Test	status_1
AV:94	Cooler Entering Fluid	R	°F			cool_ewt_1
AV:95	Cooler Heater Temp	R	°F			t_heater_1
AV:96	Cooler Leaving Fluid - Prime Variable	R	°F			cool_lwt_1
AV:97	Cooling power	R	kW			cool_pwr_1
AV:98	Limit 4-20mA Signal	R	mA			lim_anal_1
AV:99	Optional Space Temp	R	°F			spacetmp_1
AV:100	Reset/Setpoint 4-20mA Signal	R	mA			sp_reset_1
AV:101	Water pressure before cooler	R	psi			watpres1_1
AV:102	Water pressure after cooler	R	psi			watpres2_1
AV:103	Water pressure before filter	R	psi			watpres3_1

**LEGEND**

<b>CHWS</b> — Chilled Water Switch	<b>EXV</b> — Expansion Valve
<b>DGT</b> — Discharge Gas Thermistor	<b>OAT</b> — Outdoor Air Temperature
<b>DO</b> — Digital Output	<b>R</b> — Read
<b>EWT</b> — Entering Water Temperature	<b>W</b> — Write

## APPENDIX G — BACNET COMMUNICATIONS OPTION (cont)

### Table G — Network Points List (cont)

BACNET OBJECT ID	POINT NAME	READ/ WRITE	UNITS	DEFAULT VALUE	RANGE	BACNET OBJECT NAME
AV:104	Water pressure after filter	R	psi			watpres4_1
AV:105	Water flow	R	gal/sec			wat_flow_1
AV:106	Circuit Loading Sequence	R/W			0=Auto 1=A Lead 2=B Lead 3=C Lead	lead_cir_1
AV:107	Compressor A Hours	R	hr			hr_cp_a_1
AV:108	Compressor A Starts	R				st_cp_a_1
AV:109	Compressor B Hours	R	hr			hr_cp_b_1
AV:110	Compressor B Starts	R				st_cp_b_1
AV:111	Compressor C Hours	R	hr			hr_cp_c_1
AV:112	Compressor C Starts	R				st_cp_c_1
AV:113	Cooler pump #1 Hours	R	hr			hr_cpum1_1
AV:114	Cooler pump #2 Hours	R	hr			hr_cpum2_1
AV:115	Machine Operating Hours	R	hr			hr_mach_1
AV:116	Machine Starts	R				st_mach_1
AV:117	Cooler Pumps Sequence	R/W			0=No Pump 1=One Pump Only 2=Two Pumps Auto 3=Pump#1 Manual 4=Pump#2 Manual	cpumpseq_1
AV:118	Current Limit at 100%	R/W	A		0 - 2000	curr_ful_1
AV:119	Pump Auto Rotation Delay	R/W	hr		24 - 3000	pump_del_1
AV:120	Unit Off-to-On Delay	R	min			off_on_d_1
AV:121	Cooling Ice Setpoint	R/W	°F		0	ice_sp_1
AV:122	Cooling Ramp Loading	R/W	°F		0.2 - 2.0	cramp_sp_1
AV:123	Cooling Reset Degrees	R/W	°F		-30 - 30	cr_deg_1
AV:124	Cooling Setpoint 1	R/W	°F		-20 - 70	csp1_1
AV:125	Cooling Setpoint 2	R/W	°F		-20 - 70	csp2_1
AV:126	Current Full Reset Value	R/W	mA		0 - 20	v_cr_fu_1
AV:127	Current No Reset Value	R/W	mA		0 - 20	v_cr_no_1
AV:128	Delta T Full Reset Value	R/W	°F		0 - 25	dt_cr_fu_1
AV:129	Delta T No Reset Value	R/W	°F		0 - 25	dt_cr_no_1
AV:130	OAT Full Reset Value	R/W	°F		14 - 125	oatcr_fu_1
AV:131	OAT No Reset Value	R/W	°F		14 - 125	oatcr_no_1
AV:132	Space T Full Reset Value	R/W	°F		14 - 125	spacr_fu_1
AV:133	Space T No Reset Value	R/W	°F		14 - 125	spacr_no_1
AV:134	Switch Limit Setpoint 1	R/W	%		0 - 100	lim_sp1_1
AV:135	Switch Limit Setpoint 2	R/W	%		0 - 100	lim_sp2_1
AV:136	Switch Limit Setpoint 3	R/W	%		0 - 100	lim_sp3_1
AV:137	Alarm State	R			0=Normal 1=Partial 2=Shutdown	alm_1
AV:2901	User Defined Analog 1	R/W				user_analog_1_1
AV:2902	User Defined Analog 2	R/W				user_analog_2_1
AV:2903	User Defined Analog 3	R/W				user_analog_3_1
AV:2904	User Defined Analog 4	R/W				user_analog_4_1
AV:2905	User Defined Analog 5	R/W				user_analog_5_1
AV:9006	System Cooling Demand Level	R				cool_demand_level_1
AV:80001	System OAT Master	R	°F			mstr_oa_temp_1

#### LEGEND

<b>CHWS</b> — Chilled Water Switch	<b>EXV</b> — Expansion Valve
<b>DGT</b> — Discharge Gas Thermistor	<b>OAT</b> — Outdoor Air Temperature
<b>DO</b> — Digital Output	<b>R</b> — Read
<b>EWT</b> — Entering Water Temperature	<b>W</b> — Write

**APPENDIX G — BACNET COMMUNICATIONS OPTION (cont)**

**Table G — Network Points List (cont)**

BACNET OBJECT ID	POINT NAME	READ/ WRITE	UNITS	DEFAULT VALUE	RANGE	BACNET OBJECT NAME
BV:1	Chiller Start/Stop	R/W			0=Disable 1 = Enable	chil_s_s_1
BV:2	Chiller Occupied?	R/W			0=No 1 = Yes	chil_occ_1
BV:3	Ball Valve Position	R				iso_refa_1
BV:4	Ball Valve Position	R				iso_refb_1
BV:5	Ball Valve Position	R				iso_refc_1
BV:6	Compressor Output	R				comp_a_1
BV:7	Compressor Output	R				comp_b_1
BV:8	Compressor Output	R				comp_c_1
BV:9	DGT Cooling Solenoid	R				gascoola_1
BV:10	DGT Cooling Solenoid	R				gascoolb_1
BV:11	DGT Cooling Solenoid	R				gascoolc_1
BV:12	Fan Output DO #1	R				fan_a1_1
BV:13	Fan Output DO #2	R				fan_a2_1
BV:14	Fan Output DO #3	R				fan_a3_1
BV:15	Fan Output DO #4	R				fan_a4_1
BV:16	Fan Output DO #5	R				fan_a5_1
BV:17	Fan Output DO #6	R				fan_a6_1
BV:18	Fan Output DO #7	R				fan_a7_1
BV:19	Fan Output DO #8	R				fan_a8_1
BV:20	Fan Output DO #1	R				fan_b1_1
BV:21	Fan Output DO #2	R				fan_b2_1
BV:22	Fan Output DO #3	R				fan_b3_1
BV:23	Fan Output DO #4	R				fan_b4_1
BV:24	Fan Output DO #5	R				fan_b5_1
BV:25	Fan Output DO #6	R				fan_b6_1
BV:26	Fan Output DO #7	R				fan_b7_1
BV:27	Fan Output DO #8	R				fan_b8_1
BV:28	Fan Output DO #1	R				fan_c1_1
BV:29	Fan Output DO #2	R				fan_c2_1
BV:30	Fan Output DO #3	R				fan_c3_1
BV:31	Fan Output DO #4	R				fan_c4_1
BV:32	Fan Output DO #5	R				fan_c5_1
BV:33	Fan Output DO #6	R				fan_c6_1
BV:34	Fan Output DO #7	R				fan_c7_1
BV:35	Fan Output DO #8	R				fan_c8_1
BV:36	Free Cooling Disable	R/W			No/Yes	fc_dsble_1
BV:37	Heat Reclaim Select	R/W			No/Yes	recl_sel_1
BV:38	Hot Gas Bypass A Output	R				hgbp_a_1
BV:39	Hot Gas Bypass B Output	R				hgbp_b_1
BV:40	Hot Gas Bypass C Output	R				hgbp_c_1
BV:41	Oil Heater Output	R				oil_ht_a_1
BV:42	Oil Heater Output	R				oil_ht_b_1
BV:43	Oil Heater Output	R				oil_ht_c_1
BV:44	Oil Level Input	R				oil_l_a_1
BV:45	Oil Level Input	R				oil_l_b_1
BV:46	Oil Level Input	R				oil_l_c_1
BV:47	Oil Solenoid Output	R				oil_sl_a_1
BV:48	Oil Solenoid Output	R				oil_sl_b_1
BV:49	Oil Solenoid Output	R				oil_sl_c_1
BV:50	Slide Valve 1 Output	R				slid_1_a_1
BV:51	Slide Valve 2 Output	R				slid_2_a_1
BV:52	Slide Valve 1 Output	R				slid_1_b_1

**LEGEND**

<b>CHWS</b> — Chilled Water Switch	<b>EXV</b> — Expansion Valve
<b>DGT</b> — Discharge Gas Thermistor	<b>OAT</b> — Outdoor Air Temperature
<b>DO</b> — Digital Output	<b>R</b> — Read
<b>EWT</b> — Entering Water Temperature	<b>W</b> — Write



## APPENDIX G — BACNET COMMUNICATIONS OPTION (cont)

### Table G — Network Points List (cont)

BACNET OBJECT ID	POINT NAME	READ/ WRITE	UNITS	DEFAULT VALUE	RANGE	BACNET OBJECT NAME
BV:53	Slide Valve 2 Output	R				slid_2_b_1
BV:54	Slide Valve 1 Output	R				slid_1_c_1
BV:55	Slide Valve 2 Output	R				slid_2_c_1
BV:56	Emergency Stop	R/W			0=Disable,1=Enable	emstop_1
BV:57	Setpoint Occupied?	R			0=No, 1=Yes	sp_occ_1
BV:58	Startup Delay in Effect	R				mode_01_1
BV:59	Second Setpoint in Use	R				mode_02_1
BV:60	Reset in Effect	R				mode_03_1
BV:61	Demand Limit Active	R				mode_04_1
BV:62	Ramp Loading Active	R				mode_05_1
BV:63	Cooler Heater Active	R				mode_06_1
BV:64	Cooler Pumps Rotation	R				mode_07_1
BV:65	Pump Periodic Start	R				mode_08_1
BV:66	Night Low Noise Active	R				mode_09_1
BV:67	System Manager Active	R				mode_10_1
BV:68	Master Slave Active	R				mode_11_1
BV:69	Auto Changeover Active	R				mode_12_1
BV:70	Free Cooling Active	R				mode_13_1
BV:71	Reclaim Active	R				mode_14_1
BV:72	Boiler Active	R				mode_15_1
BV:73	Heating Low EWT Lockout	R				mode_16_1
BV:74	Condenser pumps Rotation	R				mode_17_1
BV:75	Ice Mode in Effect	R				mode_18_1
BV:76	Defrost Active on Circuit A	R				mode_19_1
BV:77	Defrost Active on Circuit B	R				mode_20_1
BV:78	Low Suction Circuit A	R				mode_21_1
BV:79	Low Suction Circuit B	R				mode_22_1
BV:80	Low Suction Circuit C	R				mode_23_1
BV:81	High DGT Circuit A	R				mode_24_1
BV:82	High DGT Circuit B	R				mode_25_1
BV:83	High DGT Circuit C	R				mode_26_1
BV:84	High Pressure Override Circuit A	R				mode_27_1
BV:85	High Pressure Override Circuit B	R				mode_28_1
BV:86	High Pressure Override Circuit C	R				mode_29_1
BV:87	Low Superheat Circuit A	R				mode_30_1
BV:88	Low Superheat Circuit B	R				mode_31_1
BV:89	Low Superheat Circuit C	R				mode_32_1
BV:90	Alarm Relay Status	R				alarmout_1
BV:91	Alert Relay Status	R				alert_1
BV:92	Boiler Command	R				boiler_1
BV:93	Condenser Flow Status	R				condflow_1
BV:94	Cooler Flow Setpoint Out	R/W			Off/On	set_flow_1
BV:95	Cooler Flow Switch	R				flow_sw_1
BV:96	Cooler Heater Command	R				coolheat_1
BV:97	Cooler Pump #1 Command	R/W			Off/On	cpump_1_1
BV:98	Cooler Pump #2 Command	R/W			Off/On	cpump_2_1
BV:99	Cooler Pump Run Status	R				cpumpdef_1
BV:100	Electrical Box Interlock	R				elec_box_1
BV:101	Ramped Loading Select	R/W			No/Yes	ramp_sel_1
BV:102	Staged Loading Sequence	R/W			No/Yes	seq_typ_1
BV:103	System Demand Limiting	R				dem_lmt_act_1
BV:104	Free Cooling Disable Switch	R				fc_sw_1

#### LEGEND

<b>CHWS</b> — Chilled Water Switch	<b>EXV</b> — Expansion Valve
<b>DGT</b> — Discharge Gas Thermistor	<b>OAT</b> — Outdoor Air Temperature
<b>DO</b> — Digital Output	<b>R</b> — Read
<b>EWT</b> — Entering Water Temperature	<b>W</b> — Write

## APPENDIX G — BACNET COMMUNICATIONS OPTION (cont)

### Table G — Network Points List (cont)

BACNET OBJECT ID	POINT NAME	READ/ WRITE	UNITS	DEFAULT VALUE	RANGE	BACNET OBJECT NAME
BV:105	Ice Done Storage Switch	R				ice_sw_1
BV:106	Limit Switch 1 Status	R				lim_sw1_1
BV:107	Limit Switch 2 Status	R				lim_sw2_1
BV:108	Occupied Override Switch	R				occ_ovsw_1
BV:109	On/Off - Remote Switch	R				onoff_sw_1
BV:110	Ready or Running Status	R				ready_1
BV:111	Remote Heat/Cool Switch	R				hc_sw_1
BV:112	Remote Interlock Status	R				rem_lock_1
BV:113	Remote Reclaim Switch	R				recl_sw_1
BV:114	Remote Setpoint Switch	R				setp_sw_1
BV:115	Rotate Cooler Pumps?	R/W			0=No 1=Yes	rotcpump_1
BV:116	Running Status	R				running_1
BV:117	Shutdown Indicator State	R				shutdown_1
BV:118	Current Limit Select	R/W			Off/On	curr_sel_1
BV:119	Local Schedule	R				schedule_1
BV:120	Element Communications Alarm	R				comm_lost_alm_1
BV:2911	User Defined Binary 1	R/W				user_binary_1_1
BV:2912	User Defined Binary 2	R/W				user_binary_2_1
BV:2913	User Defined Binary 3	R/W				user_binary_3_1
BV:2914	User Defined Binary 4	R/W				user_binary_4_1
BV:2915	User Defined Binary 5	R/W				user_binary_5_1
BV:2999	Element Comm Status	R				element_stat_1

#### LEGEND

<b>CHWS</b> — Chilled Water Switch	<b>EXV</b> — Expansion Valve
<b>DGT</b> — Discharge Gas Thermistor	<b>OAT</b> — Outdoor Air Temperature
<b>DO</b> — Digital Output	<b>R</b> — Read
<b>EWT</b> — Entering Water Temperature	<b>W</b> — Write

## INDEX

- 4-20 mA temperature reset 39
- Actual start-up 59
- Actuated ball valve (ABV) 67
- Alarms and alerts 88
  - Alarm control 46
  - Equipment priority 47
  - Routing control 46
  - System name 47
- BACnet communications option 168-178
- Board addresses 19
- Brine or glycol operation 30
- Broadcast acknowledgment 46
- Broadcast configuration 46
- Capacity control overrides 47
- Carrier Comfort Network® (CCN)
  - Interface 20
  - Loadshed controlled demand limit 46
    - Tables 142-156
- Chilled water flow switch 84
- Chilled water fluid type selection 28
- Circuit/compressor staging and loading 31
  - Loading 32
  - Staging 31
- Communication failure retry time 47
- Compressor
  - Assembly 77
  - Oil system 78
  - Protection 87
- Compressor protection module (CPM) 9
- Condenser coil maintenance and cleaning recommendations 85
- Condenser fans 86
- Configuration 21-59
- Control module communication 19
- Controls 8-21
- Conventions used in this manual 3
- Cooler
  - Protection 87
  - Pump control 30
- Cooling set point selection 27
- CPM DIP switch addresses 157-160
- Daylight saving time configuration 47
- Demand limit 42
  - Externally powered capacity based 43
  - Externally powered current based 43
  - Switch controlled 42
- Diagnostic alarm codes and possible causes 88
- Display module usage 3
- Dual chiller control 32
  - For parallel applications 33
  - For series applications 36
  - Pump control for parallel chiller applications 36
  - Pump control for series chiller applications 37
- Dual chiller sequence of operation 68
- Dual pump and manual control 31
- DX cooler units 82
- Economizer assembly 74
- Electronic expansion valve (EXV) 74
  - EXV board 9
  - Economizer EXV control 76
  - Main EXV control 74,75
  - Troubleshooting procedure 76
- Emergency on/off switch (SW2) 17
- Enable-off-remote contact switch (SW1) 17
- Energy Management Module (EMM) 17
- Fan boards 15
- Flooded cooler units 79
- Flow rate requirements 60
- Fluid set point control location 27
- Freeze protection 80,82
- Fresh water 28
- General (Controls) 8
- Green LED 19
- Head pressure control 50
- Heat exchangers, inspecting/cleaning 82
- Hot gas bypass/pump board 17
- Ice storage operation 46
- Leak testing 86
- Liquid fluid temperature 82
- Local equipment network 19
- Loss of fluid flow protection 81,82
- Low ambient temperature
  - head pressure control 50
  - Operating instructions 50
  - Option 50
- Low fluid temperature 80
- Machine control methods 22
- Machine on/off control 22
- Machine start delay 31
- Main Base Board (MBB) 8
- Maintenance 87,88
  - Log Sheets 165-167
- Microchannel heat exchanger
  - maintenance and cleaning 85
- Minimum fluid loop volume 60
- Minimum load control 32
- Navigator™ display module 7
  - Display tables 128-141
  - Machine control 25
- Night time/low noise applications 37
- No pump control 30
- OAT broadcast 46
- Oil separator heaters 87
- Operating limitations 60
- Operating modes 68
- Operation 67-74
- Outside air temperature reset 39
- Piping and instrumentation 161-164
- Pressure relief valves 87
- Pre-start-up 59
- Pump operation 68
- Ramp loading 38
- Re-alarm time 47
- Recommended maintenance schedule 87
- Red LED 19
- Refrigerant charge 86
- Refrigerant circuit 86
- Relief devices 87
- Remote alarm and alert relays 20
- Retubing 81,83
- Return water reset 38
- Round table plate fin condenser coil
  - maintenance and cleaning 85
- Safety considerations 2,3
- Safety devices 87
- Sensors 71
- Sequence of operation 67
- Service 74-87
- Service test 104
- Set point occupancy 27
- Single pump control 30
- Space temperature reset 39
- Start-up 59-67
- Start-up checklist for 30XA liquid chillers CL-1 to CL-8
- Suction service valve 79,82
- System check 59
- Temperature reset 38
- Thermistors 70
- Tightening cooler head bolts 81,84
- Touch Pilot display 3,19
  - Display tables 110-127
  - Machine control 22
  - Operation configuration tables 21
- Transducers 71
- Troubleshooting 88-109
- Tube plugging 81,82
- Voltage 60
- Water treatment 82
- Winter shutdown, preparation for 84
- Yellow LED 19



## START-UP CHECKLIST FOR 30XA LIQUID CHILLERS

### A. PROJECT INFORMATION

Job Name \_\_\_\_\_  
 Address \_\_\_\_\_  
 City \_\_\_\_\_ State \_\_\_\_\_ Zip \_\_\_\_\_

Installing Contractor \_\_\_\_\_  
 Sales Office \_\_\_\_\_  
 Start-up Performed By \_\_\_\_\_

### Design Information

	CAPACITY	EWT	LWT	FLUID TYPE	FLOW RATE	P.D.	AMBIENT
<b>Cooler</b>							

### Unit

Model \_\_\_\_\_ Serial \_\_\_\_\_

### Compressors

Compressor A  
 Model \_\_\_\_\_ Serial \_\_\_\_\_

Compressor B  
 Model \_\_\_\_\_ Serial \_\_\_\_\_

Compressor C  
 Model \_\_\_\_\_ Serial \_\_\_\_\_

### Cooler

Model \_\_\_\_\_ Serial \_\_\_\_\_

### B. PRELIMINARY EQUIPMENT CHECK (This section to be completed by installing contractor)

- |  |                              |                             |
|--|------------------------------|-----------------------------|
| 1. Is there any physical damage?<br>Will this prevent start-up?<br>Description _____ | <input type="checkbox"/> Yes | <input type="checkbox"/> No |
| _____  | <input type="checkbox"/> Yes | <input type="checkbox"/> No |
| 2. Unit is installed level as per the installation instructions.                     | <input type="checkbox"/> Yes | <input type="checkbox"/> No |
| 3. Power supply agrees with the unit nameplate.                                      | <input type="checkbox"/> Yes | <input type="checkbox"/> No |
| 4. Correct control voltage _____ vac.  | <input type="checkbox"/> Yes | <input type="checkbox"/> No |
| 5. Electrical power wiring is installed properly.                                    | <input type="checkbox"/> Yes | <input type="checkbox"/> No |
| 6. Unit is properly grounded.  | <input type="checkbox"/> Yes | <input type="checkbox"/> No |
| 7. Electrical circuit protection has been sized and installed properly.              | <input type="checkbox"/> Yes | <input type="checkbox"/> No |
| 8. All terminals are tight.  | <input type="checkbox"/> Yes | <input type="checkbox"/> No |
| 9. All plug assemblies are tight.  | <input type="checkbox"/> Yes | <input type="checkbox"/> No |
| 10. All cables, thermistors and transducers have been inspected for cross wires.     | <input type="checkbox"/> Yes | <input type="checkbox"/> No |
| 11. All thermistors are fully inserted into wells.                                   | <input type="checkbox"/> Yes | <input type="checkbox"/> No |
| 12. Oil separator heaters energized for 24 hours before start-up.                    | <input type="checkbox"/> Yes | <input type="checkbox"/> No |
| 13. Relief valve vent piping per local codes.  | <input type="checkbox"/> Yes | <input type="checkbox"/> No |

### Chilled Water System Check

- |  |                              |                             |
|--|------------------------------|-----------------------------|
| 1. All chilled water valves are open.  | <input type="checkbox"/> Yes | <input type="checkbox"/> No |
| 2. All piping is connected properly.   | <input type="checkbox"/> Yes | <input type="checkbox"/> No |
| 3. All air has been purged from the system.  | <input type="checkbox"/> Yes | <input type="checkbox"/> No |
| 4. Chilled water pump is operating with the correct rotation.  | <input type="checkbox"/> Yes | <input type="checkbox"/> No |
| 5. Chilled water pump starter controlled by chiller.   | <input type="checkbox"/> Yes | <input type="checkbox"/> No |
| 6. Chilled water flow switch operational.  | <input type="checkbox"/> Yes | <input type="checkbox"/> No |
| 7. Inlet piping to cooler includes a 20 mesh strainer.   | <input type="checkbox"/> Yes | <input type="checkbox"/> No |
| 8. Water loop volume greater than 3 gal/ton (40 L/kW) for air conditioning<br>or 6 gal/ton (80 L/kW) for process cooling and low ambient operation.  | <input type="checkbox"/> Yes | <input type="checkbox"/> No |
| 9. Proper loop freeze protection provided to _____ °F (°C).<br>Antifreeze type _____ Concentration _____ %.  | <input type="checkbox"/> Yes | <input type="checkbox"/> No |
| (If antifreeze solution is not utilized on 30XA machines and the minimum outdoor ambient is below 32 F (0° C) then items 10 and 11 have to be completed to provide cooler freeze protection to -20 F (-28.9 C). Refer to Installation Instructions for proper cooler winterization procedure.) |                              |                             |
| 10. Outdoor piping wrapped with electric heater tape.  | <input type="checkbox"/> Yes | <input type="checkbox"/> No |
| 11. Cooler heaters installed and operational.  | <input type="checkbox"/> Yes | <input type="checkbox"/> No |
| 12. Is the Unit equipped with low ambient head pressure control?   | <input type="checkbox"/> Yes | <input type="checkbox"/> No |
| a. If yes, are wind baffles installed?   | <input type="checkbox"/> Yes | <input type="checkbox"/> No |

Manufacturer reserves the right to discontinue, or change at any time, specifications or designs without notice and without incurring obligations.

**C. UNIT START-UP**

- 1. All liquid line service valves are open.  Yes  No
- 2. Verify actuated ball valve (ABV) operation. (Flooded Cooler Units only)  Yes  No
- 3. All suction and discharge service valves are open.  Yes  No
- 4. Economizer service valves open. (Leaving Main EXV and Leaving BPH)  Yes  No
- 5. Oil service valves open.  Yes  No
- 6. Leak check unit. Locate, repair and report any refrigerant leaks.  Yes  No
- 7. Voltage at terminal block is within unit nameplate range.  Yes  No

Check voltage imbalance: A-B \_\_\_\_\_ A-C \_\_\_\_\_ B-C \_\_\_\_\_

Average voltage = \_\_\_\_\_ (A-B + A-C + B-C)/3

Maximum deviation from average voltage = \_\_\_\_\_

Voltage imbalance = \_\_\_\_\_ % (max. deviation / average voltage) X 100

Is voltage imbalance less than 2%.

- Yes  No

(DO NOT start chiller if voltage imbalance is greater than 2%.

Contact local utility for assistance.)

8. Verify cooler flow rate

Pressure entering cooler \_\_\_\_\_ psig (kPa)

Pressure leaving cooler \_\_\_\_\_ psig (kPa)

Cooler pressure drop \_\_\_\_\_ psig (kPa)

Psig x 2.31 ft./psi = \_\_\_\_\_ ft of water

kPa x 0.334 m/psi = \_\_\_\_\_ mm of water

Cooler flow rate \_\_\_\_\_ gpm (l/s) (See Cooler Pressure Drop Curve)

**Start and Operate Machine**

- 1. Complete component test utilizing Quick Test Mode
- 2. Operate compressors and verify slide valve operation using manual test mode.
- 3. Check refrigerant and oil charge. Record charge information.
- 4. Record compressor and condenser fan motor current.
- 5. Record operating data.
- 6. Provide operating instructions to owner’s personnel.

Circuit A                      Circuit B                      Circuit C

**Refrigerant Charge**

Additional charge required      \_\_\_\_\_                      \_\_\_\_\_                      \_\_\_\_\_

**Oil Charge**

Additional charge required      \_\_\_\_\_                      \_\_\_\_\_                      \_\_\_\_\_

**Record Software Versions**

TOUCH PILOT DESCRIPTION	NAVIGATOR ITEM	NAVIGATOR SUB-MODE	ITEM EXPANSION
Software Part Number	APPL	Run Status→VERS	CSA-SR- _____

(Press ENTER and ESCAPE simultaneously to obtain software versions)

CUT ALONG DOTTED LINE

## Record Configuration Information

TOUCH PILOT™ DESCRIPTION	NAVIGATOR™ ITEM	NAVIGATOR SUBMODE	DEFAULT*	ENTRY
None (Navigator Configuration)	TEST	Configuration→DISP	OFF	
Metric Display on STDU	METR	Configuration→DISP	US	
Language Selection	LANG	Configuration→DISP	English	
Unit Type	TYPE	Configuration→UNIT	Air-Cooled	
Unit Capacity Model	TONS	Configuration→UNIT	Nominal Unit Size	
NB Fans on Varifan Cir A	VAR.A	Configuration→UNIT	0: No low ambient temperature head pressure control 1: low ambient temperature head pressure control installed	
NB Fans on Varifan Cir B	VAR.B	Configuration→UNIT	0: No low ambient temperature head pressure control 1: low ambient temperature head pressure control installed	
NB Fans on Varifan Cir C	VAR.C	Configuration→UNIT	0: No low ambient temperature head pressure control 1: low ambient temperature head pressure control installed	
Power Supply Voltage	VOLT	Configuration→UNIT	Nameplate voltage	
Power Frequency 60HZ Sel	60HZ	Configuration→UNIT	YES	
Soft Starter Select	STAR	Configuration→UNIT	NO†	
Wye Delta Start Select	Y.D	Configuration→UNIT	Unit Dependent	
Must Trip Amps (Circuit A)	MTA.A	Configuration→UNIT	Unit Dependent	
Must Trip Amps (Read Circuit A)	R.MT.A	Configuration→UNIT	Unit Dependent	
Must Trip Amps (Circuit B)	MTA.B	Configuration→UNIT	Unit Dependent	
Must Trip Amps (Read Circuit B)	R.MT.B	Configuration→UNIT	Unit Dependent	
Must Trip Amps (Circuit C)	MTA.C	Configuration→UNIT	Unit Dependent	
Must Trip Amps (Read Circuit C)	R.MT.C	Configuration→UNIT	Unit Dependent	
S1 Config Switch (Circuit A)	C.SW.A	Configuration→UNIT	Unit Dependent	
S1 Config Switch (Read Circuit A)	R.CSA	Configuration→UNIT	Unit Dependent	
S1 Config Switch (Circuit B)	C.SW.B	Configuration→UNIT	Unit Dependent	
S1 Config Switch (Read Circuit B)	R.CSB	Configuration→UNIT	Unit Dependent	
S1 Config Switch (Circuit C)	C.SW.C	Configuration→UNIT	Unit Dependent	
S1 Config Switch (Read Circuit C)	R.CSC	Configuration→UNIT	Unit Dependent	
Air Cooled Reclaim Sel	RECL	Configuration→UNIT	NO†	
DX Cooler Select	DX.CL	Configuration→UNIT	NO	
Energy Management Module	EMM	Configuration→UNIT	NO	
Password Enable	PAS.E	Configuration→UNIT	ENBL	
Factory Password	PASS	Configuration→UNIT	0111	
Cooler Heater Select	CO.HT	Configuration→UNIT	1	
Condenser Water Val Sel	CON.V	Configuration→UNIT	NO†	
Hot Gas Bypass Select	HGBP	Configuration→UNIT	NO	
MCHX Exchanger Select	MCHX	Configuration→UNIT	NO	
High Tier Display Selec	HI.TI	Configuration→UNIT	NO	
Hydronic Kit Select	H.KIT	Configuration→UNIT	NO†	
Cooler Pass Number	PA.NB	Configuration→UNIT	2	
VLT Fan Drive Select	VLT	Configuration→UNIT	NONE†	
VLT Fan Drive RPM	RPM	Configuration→UNIT	0†	
High Condensing Select	H.CON	Configuration→UNIT	NO†	
Cooler Fluid Type	FLUD	Configuration→SERV	WATER	
Condenser Fluid Type	CFLU	Configuration→SERV	WATER†	
EXV MOP Setpoint	MOP	Configuration→SERV	62	
High Pressure Threshold	HP.TH	Configuration→SERV	290.0	

\* Based on Navigator controls.

† Not supported.

## Record Configuration Information

TOUCH PILOT™ DESCRIPTION	NAVIGATOR™ ITEM	NAVIGATOR SUBMODE	DEFAULT*	ENTRY
EXV A Superheat Setpoint	SHP.A	Configuration→SERV	Unit dependent	
EXV B Superheat Setpoint	SHP.B	Configuration→SERV	Unit dependent	
EXV C Superheat Setpoint	SHP.C	Configuration→SERV	Unit dependent	
Cooler Heater Delta Spt	HTR	Configuration→SERV	2.0 (Number of degrees added to brine freeze set point to enable cooler heater.)	
Entering Fluid Control	EWTO	Configuration→SERV	NO	
Auto Start When SM Lost	AU.SM	Configuration→SERV	NO	
Brine Freeze Setpoint	LOSP	Configuration→SERV	34	
Brine Flow Switch SP	FL.SP	Configuration→SERV	1†	
Varifan Proportional Gain	HD.PG	Configuration→SERV	2.0	
Varifan Derivative Gain	HD.DG	Configuration→SERV	0.4	
Varifan Integral Gain	HD.IG	Configuration→SERV	0.2	
Element	CCNA	Configuration→OPTN	1	
Bus	CCNB	Configuration→OPTN	0	
Baud Rate	BAUD	Configuration→OPTN	9600	
Circuit Loading Sequence	LOAD	Configuration→OPTN	EQUAL	
Staged Loading Sequence	LLCS	Configuration→OPTN	AUTOMATIC	
Ramp Loading Select	RL.S	Configuration→OPTN	DSBL	
Unit Off to On Delay	DELY	Configuration→OPTN	1	
Ice Mode Enable	ICE.M	Configuration→OPTN	DSBL	
Condenser Pumps Sequence†	HPUM	Configuration→OPTN	NO PUMP	
Cooler Pumps Sequence	PUMP	Configuration→OPTN	NO PUMP	
Pump Auto Rotation Delay	ROT.P	Configuration→OPTN	48	
Pump Sticking Protection	PM.PS	Configuration→OPTN	NO	
Stop Pump During Standby	P.SBY	Configuration→OPTN	NO	
Flow Checked if C Pump On	P.LOC	Configuration→OPTN	NO	
Start Hour (Night Control)	LS.ST	Configuration→OPTN	00.00	
End Hour (Night Control)	LS.ND	Configuration→OPTN	00.00	
Capacity Limit (Night Control)	LS.LT	Configuration→OPTN	100	
Reverse Alarms Relay	RV.AL	Configuration→OPTN	NO	
Heating OAT Threshold*	OA.TH	Configuration→OPTN	5 F	
Current Limit Select	CUR.S	Configuration→OPTN	NO	
Current Limit at 100%	CUR.F	Configuration→OPTN	2000	
Cooling Reset Select	CRST	Configuration→RSET	NO RESET	
Heating Reset Select	HRST	Configuration→RSET	NO RESET	
Demand Limit Type Select	DMDC	Configuration→RSET	NONE	
mA for 100% Demand Limit	DMMX	Configuration→RSET	0.0	
mA for 0% Demand Limit	DMZE	Configuration→RSET	10.0	
Master/Slave Select	MSSL	Configuration→RSET	DISABLE	
Slave Address	SLVA	Configuration→RSET	2	
Lead/Lag Select	LLBL	Configuration→RSET	ALWAYS LEAD	
Lead/Lag Balance Delta	LLBD	Configuration→RSET	168	
Lag Start Timer	LLDY	Configuration→RSET	10	
Start if Error Higher	LL.ER	Configuration→RSET	4	
Lag Minimum Running Time	LAG.M	Configuration→RSET	0	
Lag Unit Pump Control	LAGP	Configuration→RSET	OFF IF U STP	
Lead Pulldown Time	LPUL	Configuration→RSET	0	
Chiller in Series	SERI	Configuration→RSET	NO	

\* Based on Navigator controls.

† Not supported.

CUT ALONG DOTTED LINE

CUT ALONG DOTTED LINE



## Record Configuration Information

TOUCH PILOT™ DESCRIPTION	NAVIGATOR™ ITEM	NAVIGATOR SUBMODE	DEFAULT	ENTRY
Cooling Setpoint 1	CSP.1	Set Point→COOL	44.0	
Cooling Setpoint 2	CSP.2	Set Point→COOL	44.0	
Cooling Ice Setpoint	CSP.3	Set Point→COOL	44.0	
Current No Reset Value (Cooling)	CRV1	Set Point→COOL	0	
Current Full Reset Value (Cooling)	CRV2	Set Point→COOL	0	
Delta T No Reset Value (Cooling)	CRT1	Set Point→COOL	0	
Delta T Full Reset Value (Cooling)	CRT2	Set Point→COOL	0	
OAT No Reset Value (Cooling)	CRO1	Set Point→COOL	14.0	
OAT Full Reset Value (Cooling)	CRO2	Set Point→COOL	14.0	
Space T No Reset Value	CRS1	Set Point→COOL	14.0	
Space T Full Reset Value	CRS2	Set Point→COOL	14.0	
Cooling Reset Deg. Value	DGRC	Set Point→COOL	0	
Cool Changeover Setpoint	CAUT	Set Point→COOL	75	
Cooling Ramp Loading	CRMP	Set Point→COOL	1.0	
Switch Limit Setpoint 1	DLS1	Set Point→MISC	100	
Switch Limit Setpoint 2	DLS2	Set Point→MISC	100	
Switch Limit Setpoint 3	DLS3	Set Point→MISC	100	
Water Val Condensing Stp*	W.SCT	Set Point→MISC	95.0	
Equipment Start (I/O Button)	OPER	Operating Modes→SLCT	SWITCH CTRL	
Setpoint Select	SP.SE	Operating Modes→SLCT	SET POINT OOC	
Heat/Cool Select	HC.SE	Operating Modes→SLCT	COOLING	

\*Not supported.

**Component Test — Complete the following tests to make sure all peripheral components are operational before the compressors are started.**

<b>TOUCH PILOT™ DESCRIPTION</b>	<b>NAVIGATOR™ ITEM</b>	<b>NAVIGATOR SUBMODE</b>	<b>CHECK WHEN COMPLETE</b>
Service Test Enable	T.REQ	Service Test→TEST	
Compressor A Output	CP.A	Service Test→TEST	
Slide Valve Capacity A	SLI.A	Service Test→TEST	
Compressor B Output	CP.B	Service Test→TEST	
Slide Valve Capacity B	SLI.B	Service Test→TEST	
Compressor C Output	CP.C	Service Test→TEST	
Slide Valve Capacity C	SLI.C	Service Test→TEST	
Quick Test Enable	Q.REQ	Service Test→QUIC	
Circuit A EXV Position	EXV.A	Service Test→QUIC	
Circuit B EXV Position	EXV.B	Service Test→QUIC	
Circuit C EXV Position	EXV.C	Service Test→QUIC	
Cir A Economizer EXV Position	ECO.A	Service Test→QUIC	
Cir B Economizer EXV Position	ECO.B	Service Test→QUIC	
Cir C Economizer EXV Position	ECO.C	Service Test→QUIC	
Circuit A Fan Stages	FAN.A	Service Test→QUIC	
Circuit B Fan Stages	FAN.B	Service Test→QUIC	
Circuit C Fan Stages	FAN.C	Service Test→QUIC	
Circuit A Head Pressure Speed	SPD.A	Service Test→QUIC	
Circuit B Head Pressure Speed	SPD.B	Service Test→QUIC	
Circuit C Head Pressure Speed	SPD.C	Service Test→QUIC	
Circuit A Oil Heater	HT.A	Service Test→QUIC	
Circuit A Slide Valve 1	SL1.A	Service Test→QUIC	
Circuit A Slide Valve 2	SL2.A	Service Test→QUIC	
Circuit A Hot Gas Bypass	HGPA	Service Test→QUIC	
Circuit A Oil Solenoid	OLS.A	Service Test→QUIC	
Circuit A DGT Cool Solenoid	DGT.A	Service Test→QUIC	
Circuit B Oil Heater	HT.B	Service Test→QUIC	
Circuit B Slide Valve 1	SL1.B	Service Test→QUIC	
Circuit B Slide Valve 2	SL2.B	Service Test→QUIC	
Circuit B Hot Gas Bypass	HGP.B	Service Test→QUIC	
Circuit B Oil Solenoid	OLS.B	Service Test→QUIC	
Circuit B DGT Cool Solenoid	DGT.B	Service Test→QUIC	
Circuit C Oil Heater	HT.C	Service Test→QUIC	
Circuit C Slide Valve 1	SL1.C	Service Test→QUIC	
Circuit C Slide Valve 2	SL2.C	Service Test→QUIC	
Circuit C Hot Gas Bypass	HGP.C	Service Test→QUIC	
Circuit C Oil Solenoid	OLS.C	Service Test→QUIC	
Water Exchanger Pump 1	PMP.1	Service Test→QUIC	
Water Exchanger Pump 2	PMP.2	Service Test→QUIC	
Cooler Heater Output	CL.HT	Service Test→QUIC	
Cir A Heater Ball Valve	BVL.A	Service Test→QUIC	
Cir B Heater Ball Valve	BVL.B	Service Test→QUIC	
Cir C Heater Ball Valve	BVL.C	Service Test→QUIC	
Chiller Ready Status	Q.RDY	Service Test→QUIC	
Chiller Running Output	Q.RUN	Service Test→QUIC	
Customer Shutdown Out	SHUT	Service Test→QUIC	
Chiller Capacity in 0-10V	CATO	Service Test→QUIC	
Alarm Relay Output	ALRM	Service Test→QUIC	
Alert Relay Output	ALRT	Service Test→QUIC	

CUT ALONG DOTTED LINE

CUT ALONG DOTTED LINE

**Operating Data:**

Record the following information from the Run Status, Temperatures and Outputs Modes when machine is in a stable operating condition.

TEMPERATURES

COOLER ENTERING FLUID EWT \_\_\_\_\_  
 COOLER LEAVING FLUID LWT \_\_\_\_\_  
 CONTROL POINT CTPT \_\_\_\_\_  
 CAPACITY CAP \_\_\_\_\_  
 OUTSIDE AIR TEMPERATURE OAT \_\_\_\_\_  
 LEAD/LAG LEAVING FLUID CHWS \_\_\_\_\_ (Dual Chiller Control Only)

CIRCUIT A	CIRCUIT B	CIRCUIT C
SCT.A _____	SCT.B _____	SCT.C _____
SST.A _____	SST.B _____	SST.C _____
DGT.A _____	DGT.B _____	DGT.C _____
SGT.A _____	SGT.B _____	SGT.C _____
SUP.A _____	SUP.B _____	SUP.C _____
ECT.A _____	ECT.B _____	ECT.C _____
ESH.A _____	ESH.B _____	ESH.C _____
CTP.A _____	CTP.B _____	CTP.C _____
EXV.A _____	EXV.B _____	EXV.C _____
ECO.A _____	ECO.B _____	ECO.C _____

NOTE: EXV A,B,C positions are found in the output mode.

COMPRESSOR MOTOR CURRENT

	L1	L2	L3
COMPRESSOR A1	_____	_____	_____
COMPRESSOR B1	_____	_____	_____
COMPRESSOR C1	_____	_____	_____

CONDENSER FAN MOTOR CURRENT

	L1	L2	L3
FAN MOTOR 1	_____	_____	_____
FAN MOTOR 2	_____	_____	_____
FAN MOTOR 3	_____	_____	_____
FAN MOTOR 4	_____	_____	_____
FAN MOTOR 5	_____	_____	_____
FAN MOTOR 6	_____	_____	_____
FAN MOTOR 7	_____	_____	_____
FAN MOTOR 8	_____	_____	_____
FAN MOTOR 9	_____	_____	_____
FAN MOTOR 10	_____	_____	_____
FAN MOTOR 11	_____	_____	_____
FAN MOTOR 12	_____	_____	_____
FAN MOTOR 13	_____	_____	_____
FAN MOTOR 14	_____	_____	_____
FAN MOTOR 15	_____	_____	_____
FAN MOTOR 16	_____	_____	_____
FAN MOTOR 17	_____	_____	_____
FAN MOTOR 18	_____	_____	_____
FAN MOTOR 19	_____	_____	_____
FAN MOTOR 20	_____	_____	_____
FAN MOTOR 21	_____	_____	_____
FAN MOTOR 22	_____	_____	_____

