



# Installation, Start-Up and Service Instructions

## CONTENTS

	Page
SAFETY CONSIDERATIONS .....	1-2
INTRODUCTION .....	2-8
Unit Identification .....	2
PREINSTALLATION .....	9-12
Rigging .....	9
Suspended Units .....	9
Service Clearance .....	9
Condensate Drain .....	9
External Vibration Isolators .....	9
INSTALLATION .....	13-35
Base Rail Split .....	13
Mixing Box .....	14
Condensate Drain .....	16
Variable Frequency Drive (VFD) .....	16
Install Fan Motor .....	16
Install Sheaves on Motor and Fan Shafts .....	16
Install V-Belts .....	17
Water and Steam Coil Piping Recommendations .....	19
Coil Freeze-Up Protection .....	22
Refrigerant Piping, Direct Expansion (DX) Coils .....	24
Electric Heaters .....	31
Discharge Modification .....	34
START-UP .....	35,36
Check List .....	35
SERVICE .....	36-46
General .....	36
Fan Motor Replacement .....	36
Coil Cleaning .....	36
Winter Shutdown (Chilled Water Coil Only) .....	36
Field-Installed Coils .....	37
Coil Removal .....	37
Changing Coil Hand .....	41
Filters .....	42
Fan Shaft Bearing Removal .....	43
Fan and Shaft Removal .....	45
Lubrication .....	45
Fan Sled Disassembly .....	46
METRIC CONVERSION CHART .....	47

injury to personnel and damage to equipment or property when operating this equipment, use good judgment and follow safe practices as outlined below.

### **⚠ DANGER**

NEVER enter an enclosed fan cabinet or reach into a unit while the fan is running.

LOCK OPEN AND TAG the fan motor power disconnect switch before working on a fan. Take fuses with you and note removal on tag. Electric shock can cause personal injury or death.

LOCK OPEN AND TAG the electric heat coil power disconnect switch before working on or near heaters.

### **⚠ WARNING**

CHECK the assembly and component weights to be sure that the rigging equipment can handle them safely. Note also, the centers of gravity and any specific rigging instructions.

CHECK for adequate ventilation so that fumes will not migrate through ductwork to occupied spaces when welding or cutting inside air-handling unit cabinet or plenum.

WHEN STEAM CLEANING COILS be sure that the area is clear of personnel.

DO NOT attempt to handle access covers and removable panels on outdoor units when winds are strong or gusting until you have sufficient help to control them. Make sure panels are properly secured while repairs are being made to a unit.

DO NOT remove access panel fasteners until fan is completely stopped. Pressure developed by a moving fan can cause excessive force against the panel which can injure personnel.

DO NOT work on dampers until their operators are disconnected.

BE SURE that fans are properly grounded before working on them.

## SAFETY CONSIDERATIONS

Air-handling equipment is designed to provide safe and reliable service when operated within design specifications. To avoid

**⚠ WARNING**

DO NOT USE TORCH to remove any component. System contains oil and refrigerant under pressure.

To remove a component, wear protective gloves and goggles and proceed as follows:

- a. Shut off electrical power to unit.
- b. Recover refrigerant to relieve all pressure from system using both high-pressure and low pressure ports.
- c. Traces of vapor should be displaced with nitrogen and the work area should be well ventilated. Refrigerant in contact with an open flame produces toxic gases.
- d. Cut component connection tubing with tubing cutter and remove component from unit. Use a pan to catch any oil that may come out of the lines and as a gage for how much oil to add to the system.
- e. Carefully unsweat remaining tubing stubs when necessary. Oil can ignite when exposed to torch flame.

Failure to follow these procedures may result in personal injury or death.

**⚠ CAUTION**

DO NOT re-use compressor oil or any oil that has been exposed to the atmosphere. Dispose of oil per local codes and regulations. DO NOT leave refrigerant system open to air any longer than the actual time required to service the equipment. Seal circuits being serviced and charge with dry nitrogen to prevent oil contamination when timely repairs cannot be completed. Failure to follow these procedures may result in damage to equipment.

**⚠ CAUTION**

SECURE drive sheaves with a rope or strap before working on a fan to ensure that rotor cannot free-wheel.

DO NOT restore power to unit until all temporary walkways inside components have been removed.

NEVER pressurize equipment in excess of specified test pressures.

PROTECT adjacent flammable material when welding or flame cutting. Use sheet metal or asbestos cloth to contain sparks. Have a fire extinguisher at hand and ready for immediate use.

**IMPORTANT:** The installation of air-handling units and all associated components, parts, and accessories which make up the installation and subsequent maintenance shall be in accordance with the regulations of ALL authorities having jurisdiction and MUST conform to all applicable codes. It is the responsibility of the installing contractor to determine and comply with ALL applicable codes and regulations. Field-supplied motors should be Underwriters Laboratories (UL) or Canadian Standards Association (CSA) approved. Field wiring must comply with National Electrical Code (NEC) and all local requirements.

## INTRODUCTION

**Unit Identification** — The 39L units are identified by the 18-digit part number listed on the serial plate. The part number describes all component, coil, motor, drive, and control selections. See Fig. 1-9 for unit identification.

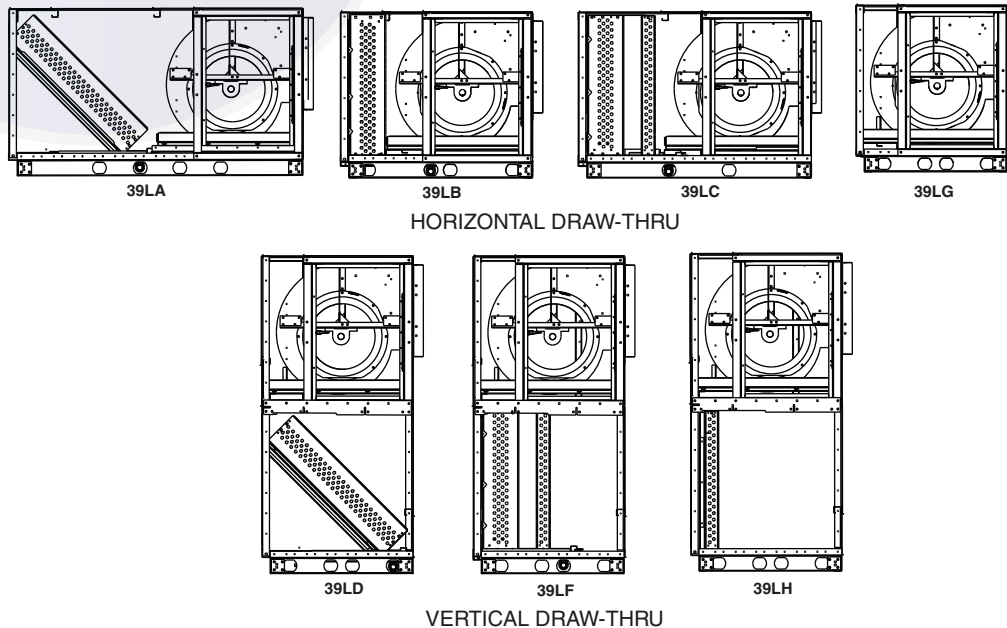

**Fig. 1 — Unit Identification**

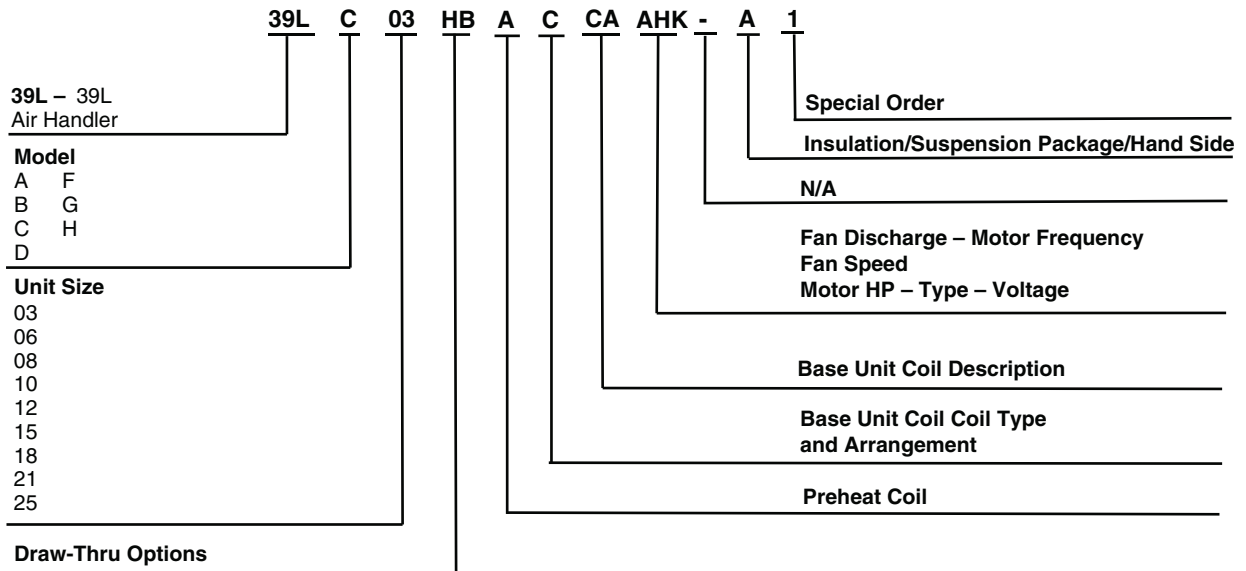

**Fig. 2 — 39L Model Number Nomenclature**

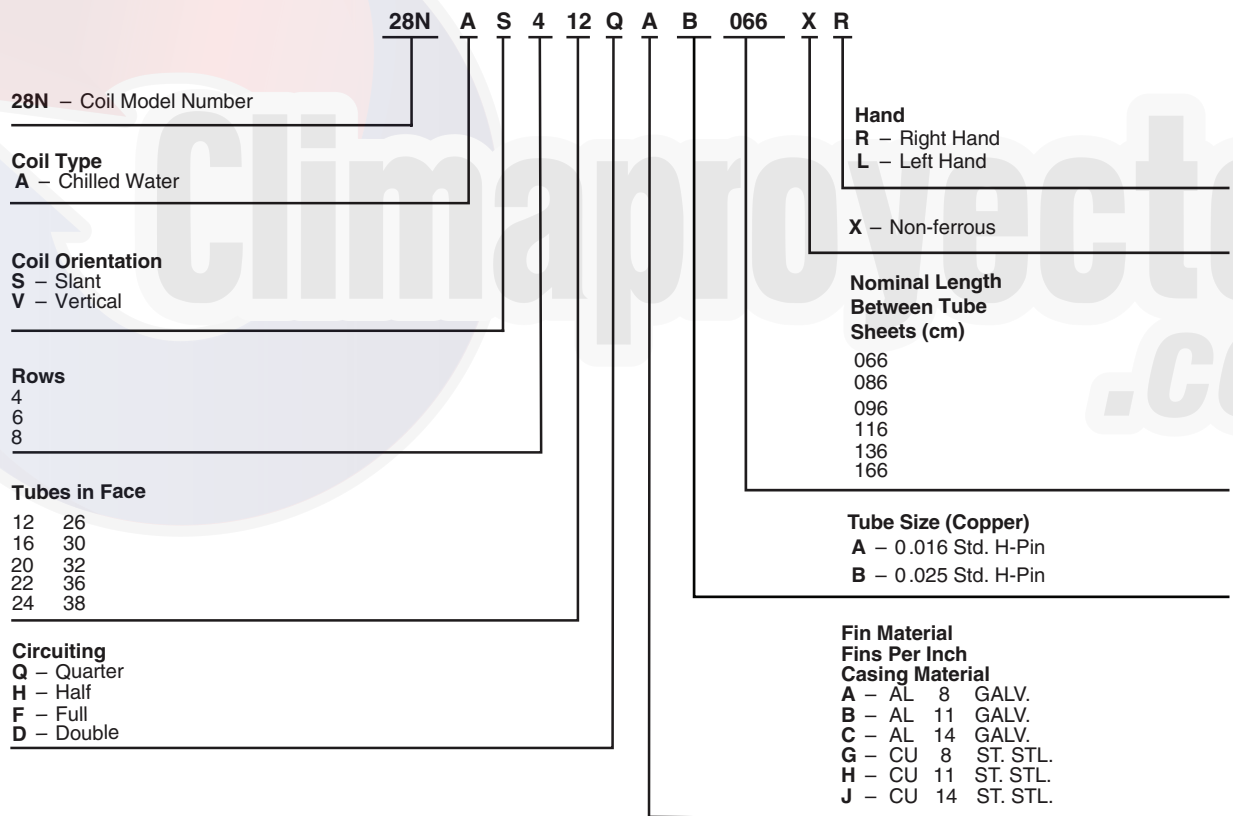

**Fig. 3 — Chilled Water Coil Model Number Nomenclature**

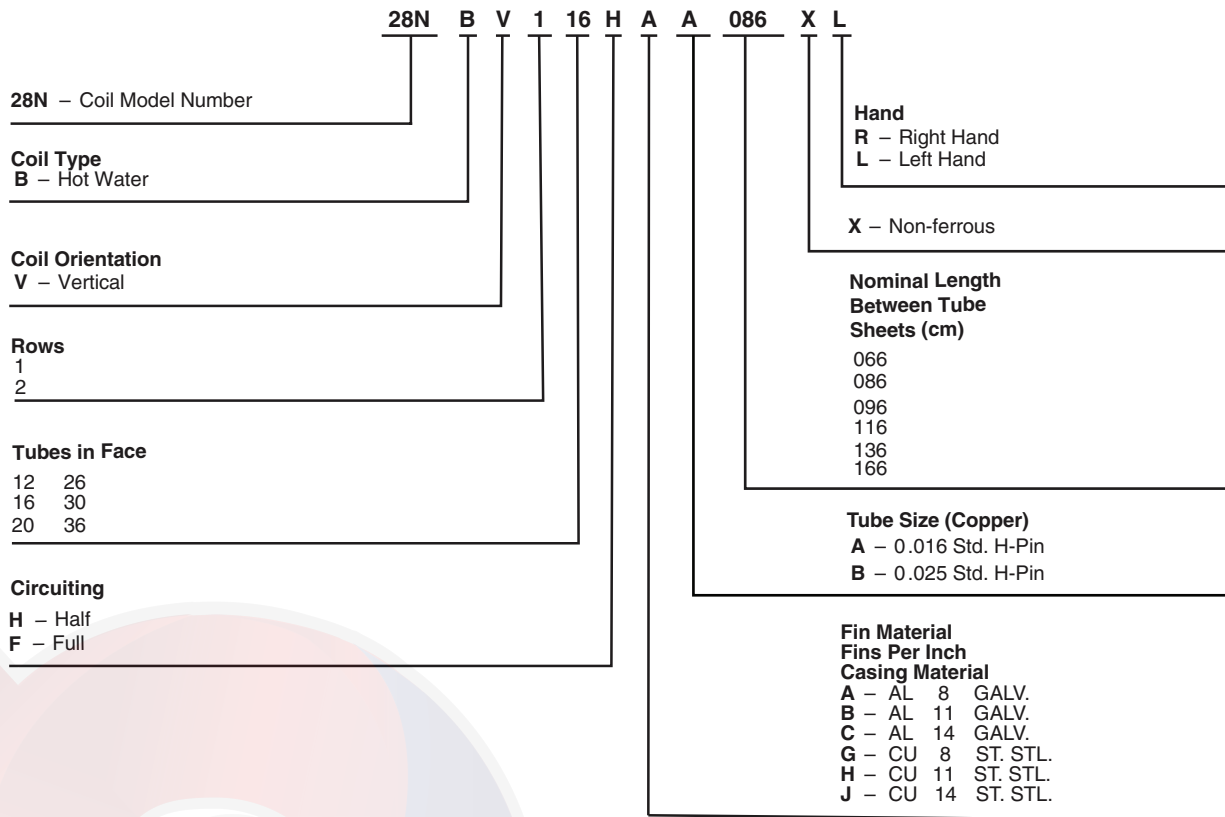

**Fig. 4 — Hot Water Coil Model Number Nomenclature**

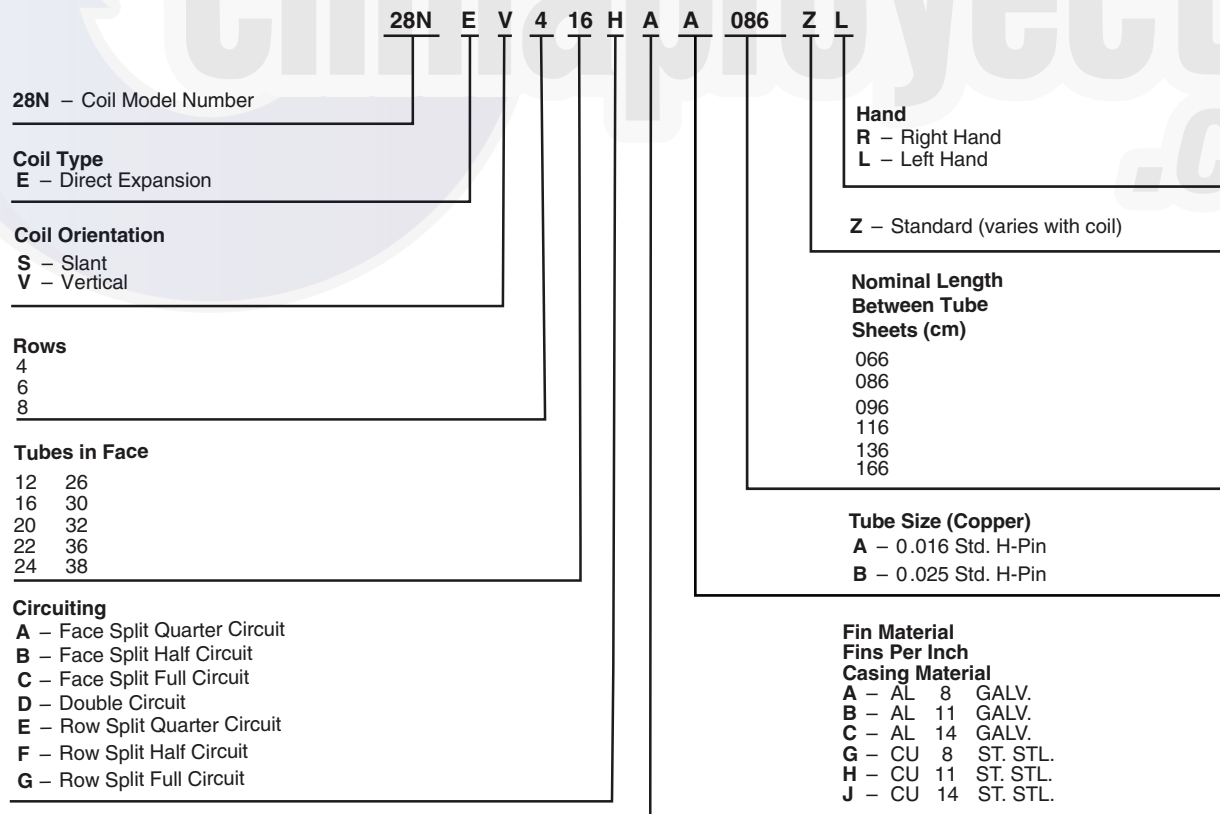

**Fig. 5 — Direct Expansion Coil Model Number Nomenclature**

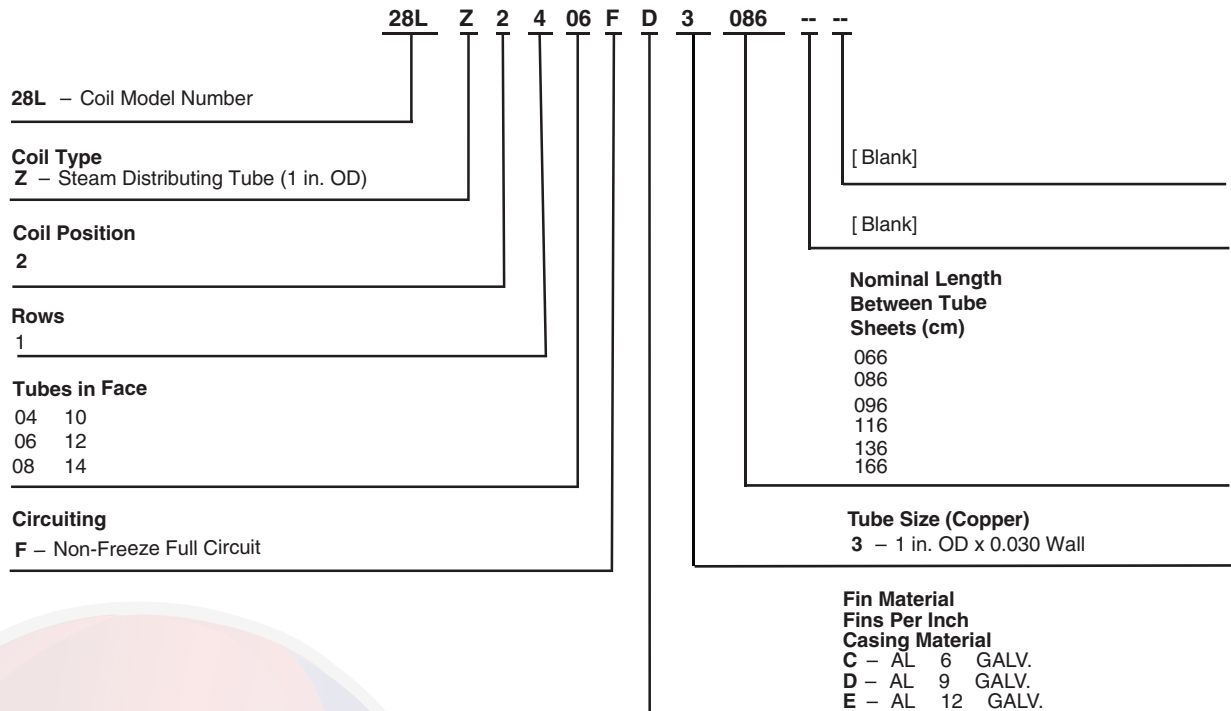

**Fig. 6 — Steam Distributing Tube Model Number Nomenclature**

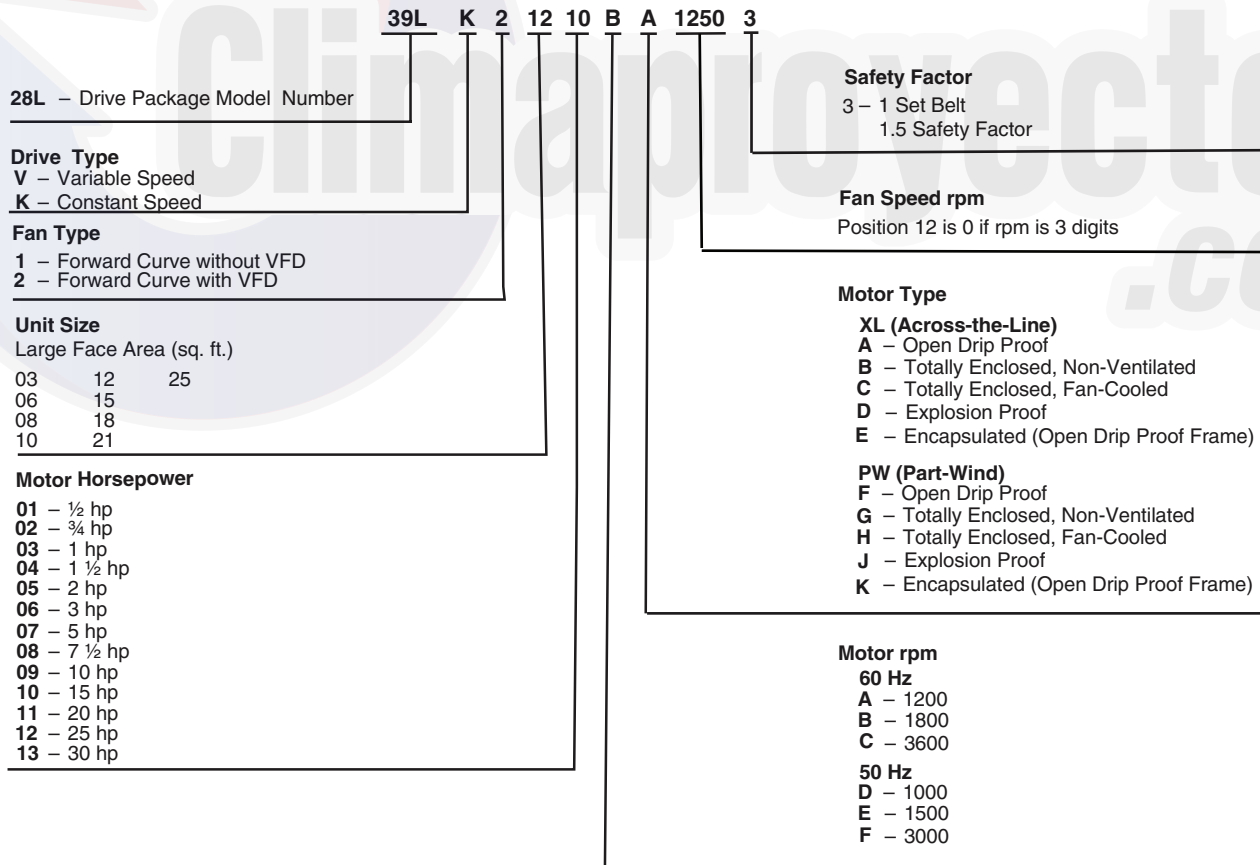

**Fig. 7 — Drive Package Model Number Nomenclature**

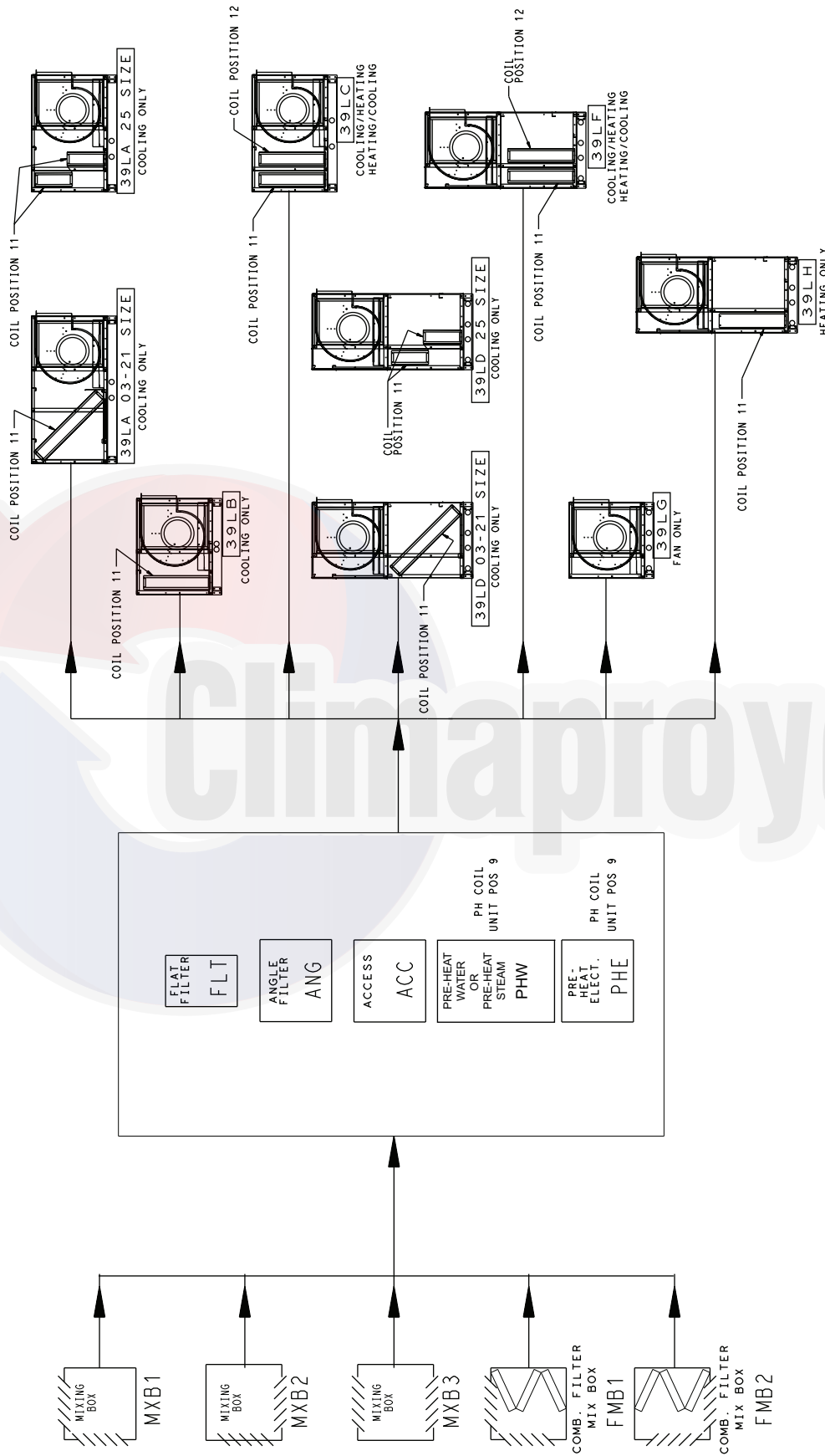
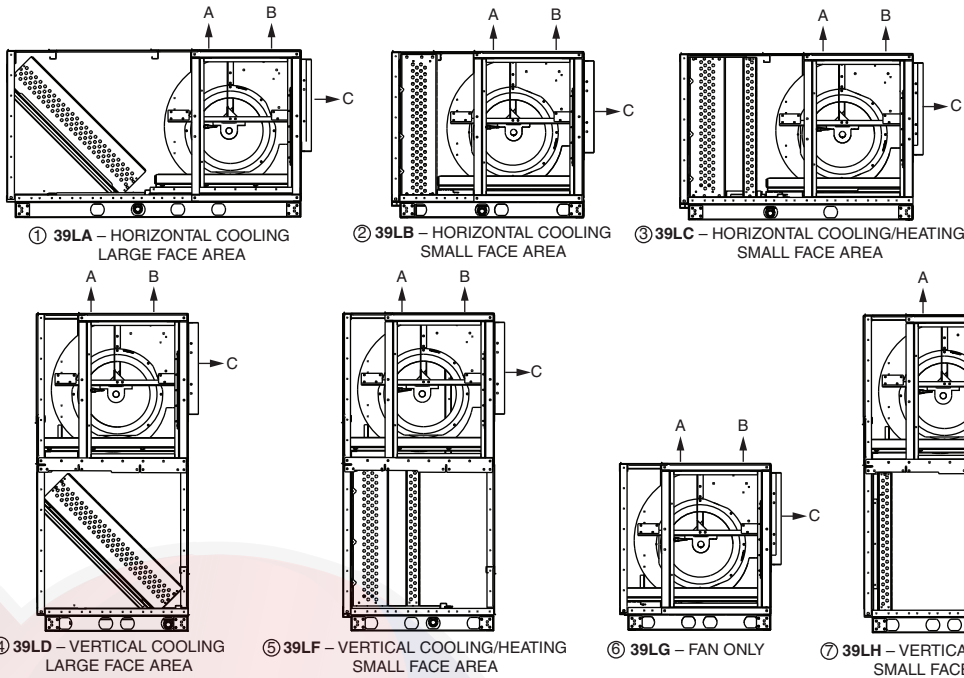

Fig. 8 — Position 4, Unit Configuration Model  
(Component Sequence Also Shown)

**LEGEND**  
 COMB. — Combination  
 PH — Preheat  
 POS. — Position  
 --- Factory-installed option components

**PRIMARY COIL/FAN SECTIONS**



**Fan Configurations**

Available Configurations	
<b>A</b>	Upblast Rear Discharge
<b>B</b>	Upblast Front Discharge
<b>C</b>	Top Horizontal Front Discharge
Fan Section Access	
Hinged Door on Hand Side	

**ACCESSORY SECTIONS**

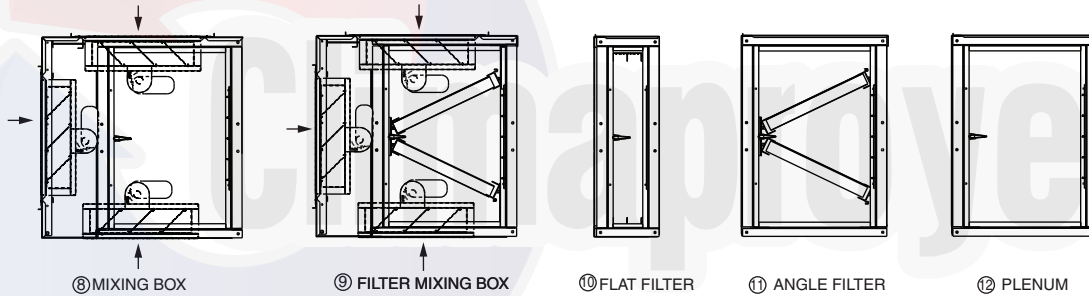

**PREHEAT SECTIONS**

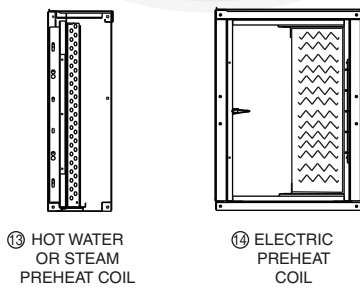

NOTE: Item numbers refer to Table 1.

**Fig. 9 — Section Details**

**Table 1 — Section Dimensions and Weights**

**SECTION DIMENSIONS (in.) AND WEIGHTS (lb)**

Nominal cfm at 500 fpm	1,500	3,000	4,000	5,000	6,000	7,500	9,000	10,500	12,500	
Unit Size	03	06	08	10	12	15	18	21	25	
Height (in.) LA, LB, LC, LG	24.3	28.2	32.1	32.1	32.1	40.0	43.9	43.9	43.9	
Height (in.) LD, LF, LH	45.5	53.3	61.3	61.3	61.3	76.9	84.8	84.8	100.6	
Width (in.)	37.9	45.8	49.7	57.6	65.1	65.1	65.1	77.3	77.3	
ITEM NO.*	DESCRIPTION	AWL (in.) Weight (lb)								
1	39LA	40.9 200	48.8 280	56.7 411	56.7 470	56.7 540	72.4 620	80.3 695	80.3 740	76.4 820
2	39LB	29.1 150	33.1 210	37.0 308	37.0 352	37.0 405	44.9 465	48.8 521	48.8 555	56.7 615
3	39LC	37.0 170	40.9 238	44.9 349	44.9 400	44.9 459	52.8 527	56.7 590	56.7 629	64.6 697
4	39LD	21.3 230	25.2 322	29.1 472	29.1 540	29.1 621	37.0 713	40.9 799	40.9 851	48.8 943
5	39LF	21.3 230	25.2 322	29.1 472	29.1 540	29.1 621	37.0 713	40.9 799	40.9 851	48.8 943
6	39LG	21.3 120	25.2 168	29.1 246	29.1 282	29.1 324	37.0 372	40.9 417	40.9 444	48.8 492
7	39LH	21.3 220	25.2 308	29.1 452	29.1 517	29.1 594	37.0 682	40.9 764	40.9 814	48.8 902

**ACCESSORIES**

Unit Size	03	06	08	10	12	15	18	21	25	
Height (in.)	24.3	28.2	32.1	32.1	32.1	40.0	43.9	43.9	43.9	
Width (in.)	37.9	45.8	49.7	57.6	65.1	65.1	65.1	77.3	77.3	
ITEM NO.*	DESCRIPTION	AWL (in.) Weight (lb)								
8	Mixing Box Section	27.6 139	27.6 164	27.6 193	27.6 219	27.6 226	27.6 244	35.4 283	35.4 272	35.4 311
9	Filter Mixing Box	27.6 150	27.6 173	27.6 208	27.6 227	27.6 245	27.6 279	35.4 327	35.4 340	35.4 395
10	Flat Filter Section	7.9 37	7.9 43	7.9 48	7.9 50	7.9 55	7.9 74	7.9 75	7.9 86	7.9 90
11	Angle Filter Section	19.7 75	19.7 82	19.7 97	19.7 107	19.7 114	19.7 134	19.7 140	19.7 159	19.7 185
12	Access Section	19.7 48	19.7 55	19.7 60	19.7 64	19.7 68	19.7 74	19.7 77	19.7 87	19.7 92
13	Preheat (Hot Water or Steam) Section	7.9 36	7.9 42	7.9 43	7.9 46	7.9 49	7.9 52	7.9 54	7.9 53	7.9 57
14	Preheat (Electric) Section	19.7 49	19.7 56	19.7 61	19.7 66	19.7 72	19.7 74	19.7 76	19.7 87	19.7 89

\* Item numbers refer to Fig. 9.

**LEGEND**

**AWL** — Airway Length

NOTE: Unit weights do not include coils and motors.



## PREINSTALLATION

1. Check items received against packing list. Notify Carrier of any discrepancy.
2. Refer to Fig. 10 for service area requirements.
3. To transfer unit from truck to storage site, refer to rigging details in Fig. 11 and section on unit rigging for proper handling. See Tables 1 and 2 for section and component weights.

### ⚠ CAUTION

If a fork lift truck is used, lift only from heavy end of skid. Minimum recommended fork length is 48 inches.

4. Do not stack unit components or accessories during storage. Stacking can cause damage or deformation.
5. If unit is to be stored for more than 2 weeks prior to installation, observe the following precautions:
  - a. Choose a dry storage site that is reasonably level and sturdy to prevent undue stress or permanent damage to the unit structure or components. Do not store unit on vibrating surface. Damage to stationary bearings can occur. Set unit off ground if in heavy rain area.
  - b. Remove all fasteners and other small parts from job-site to minimize theft. Tag and store parts in a safe place until needed.
  - c. Cover entire unit with a tarp or plastic coverall. Extend cover under unit if stored on ground. Secure cover with adequate tiedowns or store indoors. Be sure all coil connections have protective shipping caps.
  - d. Monthly — Remove tarp from unit, enter fan section through access door or through fan inlet, and rotate fan and motor slowly by hand to redistribute the bearing grease and to prevent bearing corrosion.

**Rigging (Fig. 11)** — All 39L units can be rigged by means of the lifting brackets on bottom of unit.

Units are shipped fully assembled. Do not remove shipping skids or protective covering until unit is ready for final placement. Use slings and spreader bars as applicable to lift unit. *Do not lift unit by coil connections or headers.*

Do not remove protective caps from coil piping connections until ready to connect piping.

Do not remove protective cover or grease from fan shaft until ready to install sheave.

Lay rigid temporary protection such as plywood walkways in unit to prevent damage to insulation or bottom panel during installation.

**Suspended Units** — Figure 12 shows overhead suspension of unit using optional factory-supplied suspension channels.

Each support channel consists of 2 pieces, the smaller of which fits inside the larger one. This allows the channel to be adjusted to the required length for installation.

Channels are shipped on top of the unit. The 2 sections of each channel are shipped one inside the other, and are held in place during shipping by the panel screws in the top panel.

Hardware required for installation of suspension channels is shipped in a package inside the fan section.

At least 2 suspension channels are shipped with each fan and coil unit. One or more extra channels will be supplied depending on the number of accessories ordered. Be sure to install all the suspension channels shipped with a unit. Refer to 39L Isolator Mounting (Suspended Unit) certified drawing for details.

To install suspension channels:

1. Remove panel screws to free suspension channels for installation. Replace screws in top panel.
2. Adjust channel to required length by sliding one channel section inside the other. The channel must extend at least 9 in. but not more than 12 in. beyond the edge of the unit. Set length of channel by installing factory-supplied bolts through the overlapping channel sections.
3. Mount unit to suspension channel using factory-supplied nuts and bolts through  $\frac{7}{16}$ -in. diameter holes in unit lifting bracket.
4. Install field-supplied suspension rods through  $\frac{9}{16}$ -in. diameter holes provided at outer edges of channel. Be sure hanger rods are securely fastened in place.

**Service Clearance** — Provide adequate space for unit service access (fan shaft and coil removal, filter removal, motor access, damper linkage access, etc.) as shown in Fig. 10.

**Condensate Drain** — To prevent excessive build-up of condensate in drain pan, adequate trap clearance must be provided beneath the unit. See Installation, Condensate Drain section on page 16 for additional details.

**External Vibration Isolators** — Install vibration isolators per certified drawings, and in accordance with the job specifications and the instructions of the vibration isolator manufacturer. The coil piping must be isolated or have a flexible connection to avoid coil header damage because of unit motion. A flexible connection should be installed at the fan discharge.

Fig. 12 and 13 show isolation location for overhead suspension or floor mounting of unit.

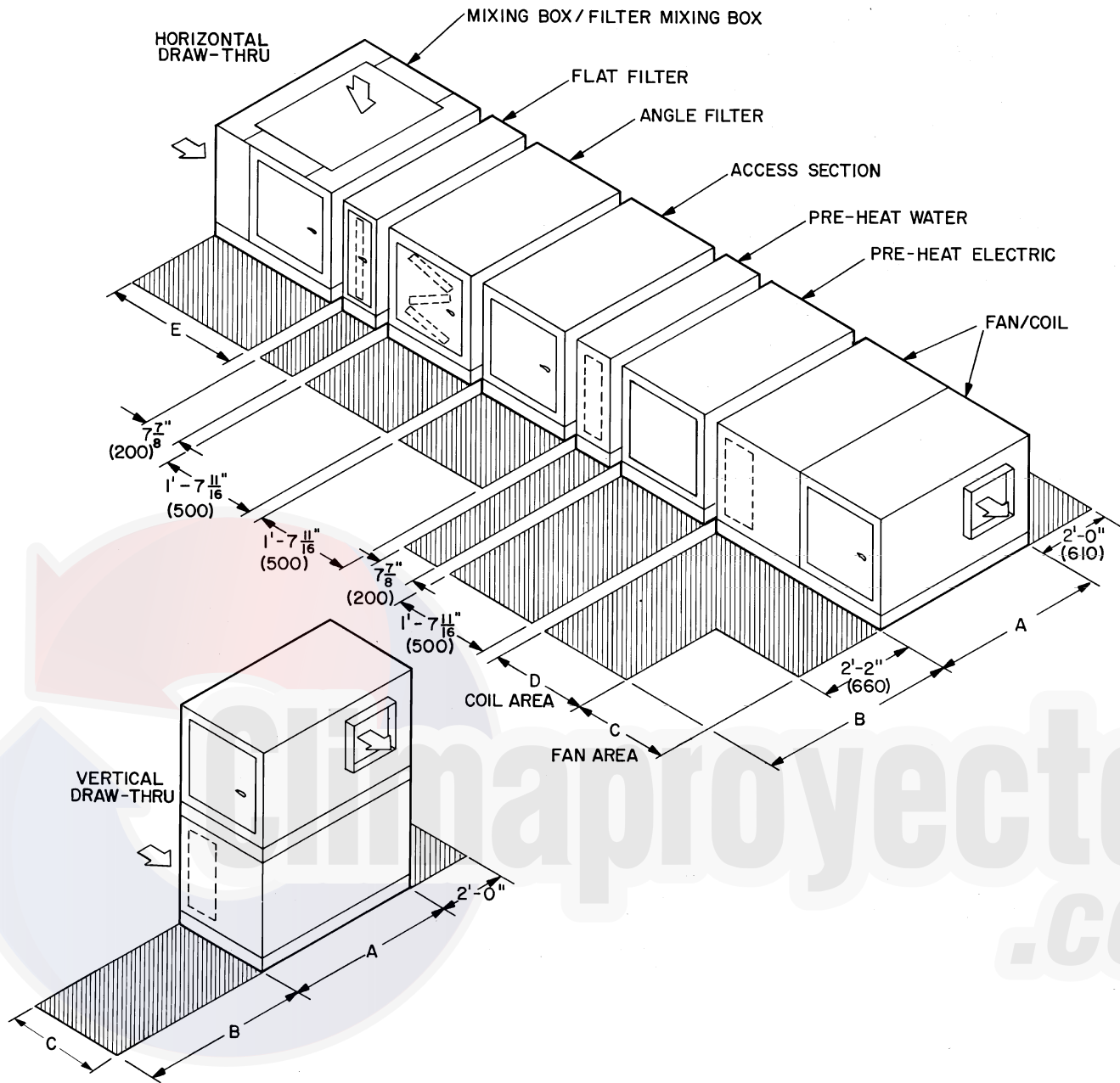

NOTE: Dimensions are in inches, ( ) are in mm.

DIMENSIONS (ft-in.)

SIZE	A	B	C	D			E
				39LA	39LB	39LC	
03	3-1 <sup>7</sup> / <sub>8</sub>	3-1 <sup>3</sup> / <sub>4</sub>	1-9 <sup>1</sup> / <sub>4</sub>	1- 7 <sup>11</sup> / <sub>16</sub>	0-7 <sup>7</sup> / <sub>8</sub>	1-3 <sup>3</sup> / <sub>4</sub>	2- 3 <sup>9</sup> / <sub>16</sub>
06	3-9 <sup>3</sup> / <sub>4</sub>	3-9 <sup>5</sup> / <sub>8</sub>	2-1 <sup>3</sup> / <sub>16</sub>	1-11 <sup>5</sup> / <sub>8</sub>	0-7 <sup>7</sup> / <sub>8</sub>	1-3 <sup>3</sup> / <sub>4</sub>	2- 3 <sup>9</sup> / <sub>16</sub>
08	4-1 <sup>11</sup> / <sub>16</sub>	4-1 <sup>9</sup> / <sub>16</sub>	2-5 <sup>1</sup> / <sub>8</sub>	2- 3 <sup>9</sup> / <sub>16</sub>	0-7 <sup>7</sup> / <sub>8</sub>	1-3 <sup>3</sup> / <sub>4</sub>	2- 3 <sup>9</sup> / <sub>16</sub>
10	4-9 <sup>9</sup> / <sub>16</sub>	4-9 <sup>7</sup> / <sub>16</sub>	2-5 <sup>1</sup> / <sub>8</sub>	2- 3 <sup>9</sup> / <sub>16</sub>	0-7 <sup>7</sup> / <sub>8</sub>	1-3 <sup>3</sup> / <sub>4</sub>	2- 3 <sup>9</sup> / <sub>16</sub>
12	5-5 <sup>1</sup> / <sub>16</sub>	5-5 <sup>5</sup> / <sub>16</sub>	2-5 <sup>1</sup> / <sub>8</sub>	2- 3 <sup>9</sup> / <sub>16</sub>	0-7 <sup>7</sup> / <sub>8</sub>	1-3 <sup>3</sup> / <sub>4</sub>	2- 3 <sup>9</sup> / <sub>16</sub>
15	5-5 <sup>1</sup> / <sub>16</sub>	5-5 <sup>5</sup> / <sub>16</sub>	3-1	2-11 <sup>9</sup> / <sub>16</sub>	0-7 <sup>7</sup> / <sub>8</sub>	1-3 <sup>3</sup> / <sub>4</sub>	2- 3 <sup>9</sup> / <sub>16</sub>
18	5-5 <sup>1</sup> / <sub>16</sub>	5-5 <sup>5</sup> / <sub>16</sub>	3-4 <sup>15</sup> / <sub>16</sub>	3- 3 <sup>3</sup> / <sub>8</sub>	0-7 <sup>7</sup> / <sub>8</sub>	1-3 <sup>3</sup> / <sub>4</sub>	2-11 <sup>7</sup> / <sub>16</sub>
21	6-5 <sup>1</sup> / <sub>4</sub>	6-5 <sup>1</sup> / <sub>8</sub>	3-4 <sup>15</sup> / <sub>16</sub>	3- 3 <sup>3</sup> / <sub>8</sub>	0-7 <sup>7</sup> / <sub>8</sub>	1-3 <sup>3</sup> / <sub>4</sub>	2-11 <sup>7</sup> / <sub>16</sub>
25	6-5 <sup>1</sup> / <sub>4</sub>	6-5 <sup>1</sup> / <sub>8</sub>	4-0 <sup>15</sup> / <sub>16</sub>	2- 3 <sup>9</sup> / <sub>16</sub>	0-7 <sup>7</sup> / <sub>8</sub>	1-3 <sup>3</sup> / <sub>4</sub>	2-11 <sup>7</sup> / <sub>16</sub>

DIMENSIONS (mm)

SIZE	A	B	C	D			E
				39LA	39LB	39LC	
03	952	959	540	500	200	400	700
06	1162	1159	640	600	200	400	700
08	1262	1259	740	700	200	400	700
10	1462	1459	740	700	200	400	700
12	1653	1659	740	700	200	400	700
15	1653	1659	940	900	200	400	700
18	1653	1659	1040	1000	200	400	900
21	1962	1959	1040	1000	200	400	900
25	1962	1959	1240	700	200	400	900

Fig. 10 — Service Area Requirements

**Table 2 — Additional Component Weights**

UNIT SIZE	03	06	08	10	12	15	18	21	25
<b>TYPICAL DRY COIL WEIGHTS (lb)</b>									
<b>Large Face Area Cooling Coils, 1/2-in. OD (Chilled Water &amp; DX)*</b>									
4-Row	56	84	98	109	137	178	198	251	280
6-Row	63	95	123	138	174	234	270	327	363
<b>Small Face Area Cooling Coils, 1/2-in. OD (Chilled Water &amp; DX)*</b>									
4-Row	45	72	91	105	133	161	182	211	238
6-Row	53	85	113	129	162	197	225	270	307
8-Row	61	92	129	143	189	228	263	324	377
<b>Hot Water Coils, 1/2-in. OD*</b>									
1-Row	19	34	38	48	58	62	77	86	95
2-Row	28	43	51	61	76	89	104	117	130
<b>Steam Coils, 1-row, 1-in. OD</b>									
6-FPI	50	70	85	95	110	135	150	180	215
9-FPI	55	80	100	115	125	155	175	214	256
12-FPI	60	85	115	130	145	180	205	248	297
<b>FAN</b>									
Wheel Diameter (in.)	9 <sup>1</sup> / <sub>2</sub>	12 <sup>5</sup> / <sub>8</sub>	12 <sup>5</sup> / <sub>8</sub>	15	15	18 <sup>1</sup> / <sub>8</sub>	20	20	25
Wheel Width (in.)	7 <sup>1</sup> / <sub>8</sub>	9 <sup>1</sup> / <sub>2</sub>	11 <sup>1</sup> / <sub>8</sub>	11 <sup>1</sup> / <sub>8</sub>	15	15	13 <sup>1</sup> / <sub>2</sub>	18	15
Shaft Diameter (in.)	3/4	13 <sup>3</sup> / <sub>16</sub>	13 <sup>3</sup> / <sub>16</sub>	13 <sup>3</sup> / <sub>16</sub>	13 <sup>3</sup> / <sub>16</sub>	17 <sup>1</sup> / <sub>16</sub>	17 <sup>1</sup> / <sub>16</sub>	17 <sup>1</sup> / <sub>16</sub>	11 <sup>11</sup> / <sub>16</sub>
Maximum Fan Rpm	2500	2000	2000	1600	1600	1400	1300	1100	1000
<b>OPERATING CHARGE (Approximate), DIRECT EXPANSION COIL</b>									
<b>Refrigerant R-410A or R-22 (lb)</b>									
4-Row Coil	1-2	2-3	3-4	4-5	4-5	5-6	6-7	6-8	6-9
6-Row Coil	1-2	2-4	5-6	5-6	6-8	8-10	9-11	11-13	11-16
8-Row Coil	2-3	3-5	5-6	5-7	7-9	10-12	12-14	13-19	16-24
<b>COIL VOLUME (gal. water)</b>									
<b>Chilled Water, 1/2-in. OD Tube, Large Face Area</b>									
4-Row	2.5	3.5	4.5	5.2	5.6	7.3	8.5	10.4	12.0
6-Row	3.2	4.7	6.0	6.8	7.7	10.1	11.7	14.2	16.3
<b>Chilled Water, 1/2-in. OD Tube, Small Face Area</b>									
4-Row	2.1	3.3	3.9	4.1	5.1	6.3	7.3	8.7	9.8
6-Row	2.4	3.7	5.1	5.9	6.6	8.3	9.5	11.8	13.5
8-Row	2.7	4.1	6.4	7.4	8.4	10.7	12.1	14.7	17.2
<b>Hot Water, 1/2-in. OD Tube</b>									
1-Row	0.5	0.8	1.0	1.3	1.5	1.8	2.1	2.5	2.9
2-Row	0.7	1.3	1.6	2.0	2.4	2.9	3.4	4.0	4.8
<b>COOLING COILS</b>									
<b>Chilled Water 1/2-in. OD Tube, (4, 6 Row) Large Face Area</b>									
Face Area (sq ft)	3.63	5.90	7.90	9.54	11.18	14.91	17.71	21.6	25.0
Number of Tubes/Face	16	20	24	24	24	32	38	38	44
Finned Tube Length (in.)	26.1	34.0	37.9	45.8	53.7	53.7	53.7	65.5	65.5
<b>Chilled Water 1/2-in. OD Tube (4, 6, 8 Row) Small Face Area</b>									
Face Area (sq ft)	2.72	4.72	6.58	7.95	9.32	12.12	13.98	17.1	20.5
Number of Tubes/Face	12	16	20	20	20	26	30	30	36
Finned Tube Length (in.)	26.1	34.0	37.9	45.8	53.7	53.7	53.7	65.5	65.5
<b>DX 1/2-in. OD Tube (4, 6 Row) Large Face Area</b>									
Face Area (sq ft)	3.63	5.90	7.90	9.54	11.18	14.91	17.71	21.6	25.0
Finned Tube Length (in.)	26.1	34.0	37.9	45.8	53.7	53.7	53.7	65.5	65.5
<b>DX 1/2-in. OD Tube (4, 6, 8 Row) Small Face Area</b>									
Face Area (sq ft)	2.72	4.72	6.58	7.95	9.32	12.12	13.98	17.1	20.5
Finned Tube Length (in.)	26.1	34.0	37.9	45.8	53.7	53.7	53.7	65.5	65.5
<b>HEATING COILS</b>									
<b>Hot Water 1/2-in. OD Tube, U-Bend (1, 2 Row)</b>									
Face Area (sq ft)	2.72	4.72	6.58	7.95	9.32	12.12	13.98	17.1	20.5
Number Tubes/Face	12	16	20	20	20	26	30	30	36
Finned Tube Length (in.)	26.1	34.0	37.9	45.8	53.7	53.7	53.7	65.5	65.5
<b>Steam 1-in. OD (1 Row)</b>									
Face Area (sq ft)	2.13	4.18	6.22	7.53	8.85	11.06	13.28	16.2	18.9
Number Tubes/Face	4	6	8	8	8	10	12	12	14
Finned Tube Length (in.)	25.5	33.4	37.3	45.2	53.1	53.1	53.1	53.1	64.9

**LEGEND**

**DX** — Direct Expansion

**FPI** — Fins Per Inch

\*Coils have 14 aluminum fins per inch on copper tubes.

NOTE: See Table 1 for section weights and dimensions.

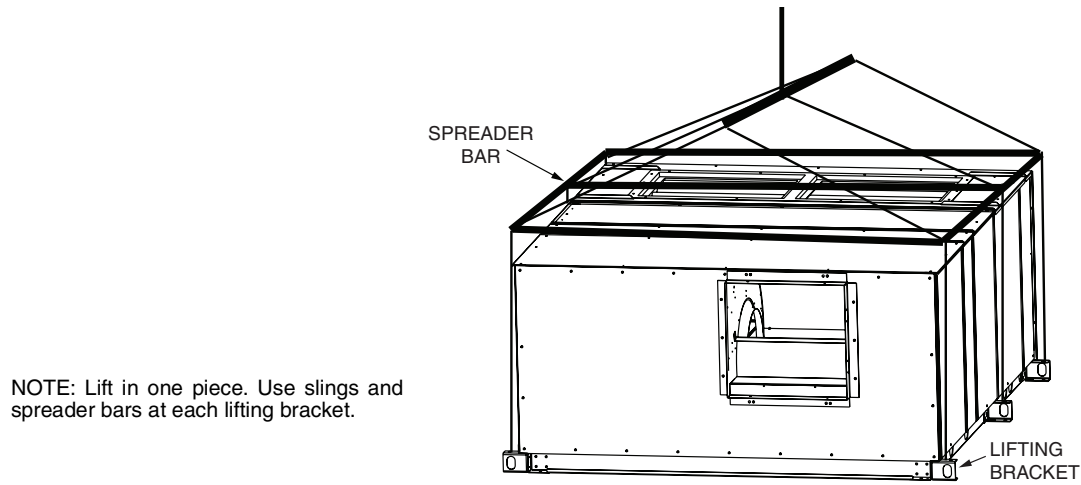

**Fig. 11 — Unit Rigging Details**

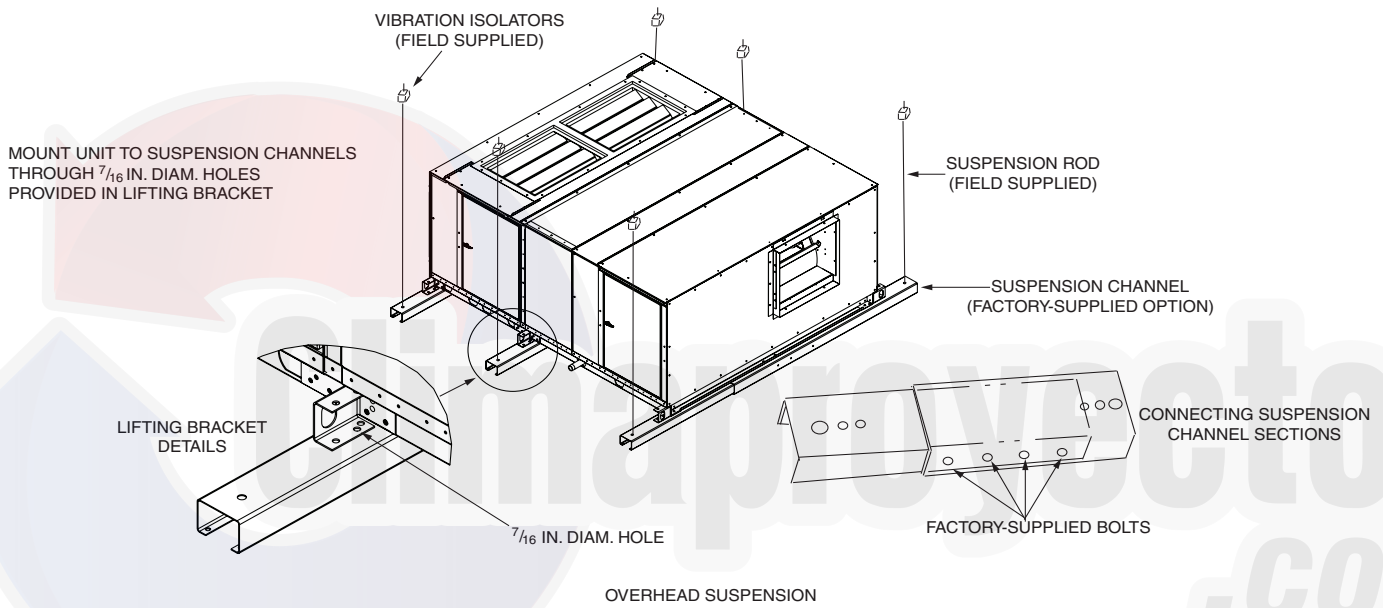

**Fig. 12 — Unit Support Details, Overhead Suspension**

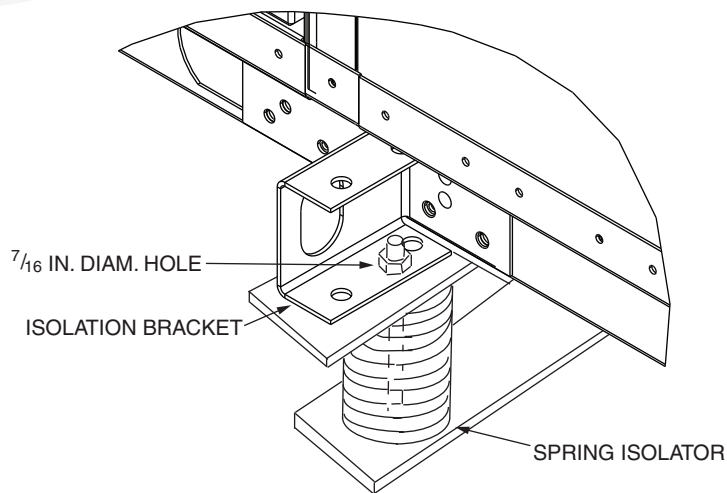

ISOLATION DETAIL – FLOOR MOUNT

**Fig. 13 — Unit Support Details, Floor Mount**

## INSTALLATION

**Base Rail Split** — A base rail split between the primary coil/fan section and the accessory sections is optional. If this option has been selected, the 39L unit will arrive at the job site assembled as one piece. The split allows the unit to be separated at the joint.

If the unit must be separated in the field, follow this procedure:

1. Remove the lifting lugs on the inlet side of the coil/fan section and those on the outlet side of the accessory section to liberate the T-bracket. See Fig 14.
2. Unscrew the flanges (top and sides) around the coil/fan section and the accessory section. See Fig. 15.

### ⚠ CAUTION

Ensure that a good seal is created between both sections before continuing. A poor seal may result in equipment damage.

NOTE: If the section-to-section gasket installed at the factory is damaged while splitting the unit, obtain the required length of  $\frac{1}{8}$  in. x  $1\frac{1}{4}$  in. foam gasketing locally.

After rejoining the split sections, fully tighten all AB  $\frac{1}{4}$  in.- $\frac{3}{4}$  in. screws on the flanges and the AB  $\frac{1}{4}$  in.- $\frac{5}{8}$  in. screws on the flanges. See Fig. 16.

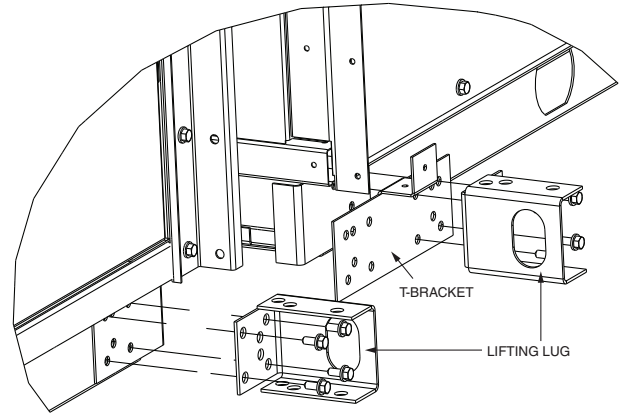

Fig. 14 — Base Rail Split — T-Bracket

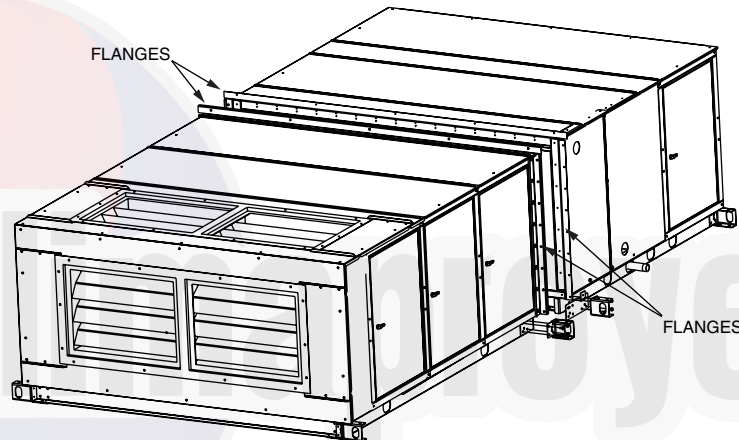

Fig. 15 — Base Rail Split — Flanges

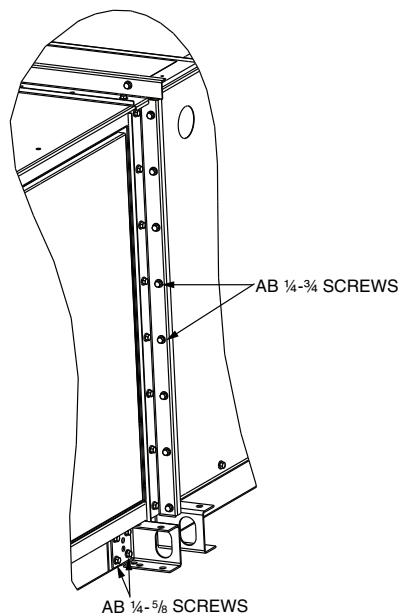

Fig. 16 — Base Rail Split — Screws

## Mixing Box

**DAMPER ACTUATORS** — The 39L mixing boxes are supplied with low leak dampers and blade and edge seals. Damper operating torques are shown in Table 3.

The actuator and mounting brackets are field supplied and may be mounted inside or outside the unit. A typical inside mounting bracket is shown in Fig. 17. For external mounting of actuators, drill or punch a hole in the exterior panel.

NOTE: If the unit is shipped with *AirManager*™ controls, actuator(s) are factory-supplied. Refer to Table 4.

To ensure torque is transmitted equally to both damper sections, actuator must be connected to the 1-in. hollow jackshaft that drives the interconnecting linkage bar. Connection to any other shaft is not recommended.

**DUCTWORK ATTACHMENT** — Ductwork should be flanged out and attached to the mixing box panels as shown in Fig. 18. See Fig. 19 for duct connection sizes.

**Table 3 — Mixing Box Damper Operating Torque (in.-lb)**

39L UNIT SIZE	TORQUE
03	20
06	20
08	26
10	29
12	33
15	41
18	52
21	56
25	76

**NOTES:**

1. Torque values are based on interconnected dampers driven by one operator. For units with separate operators for each damper, calculate torque as follows: Table values x .80 = torque per damper section.
2. Damper shaft moves 90 degrees from open to closed position.

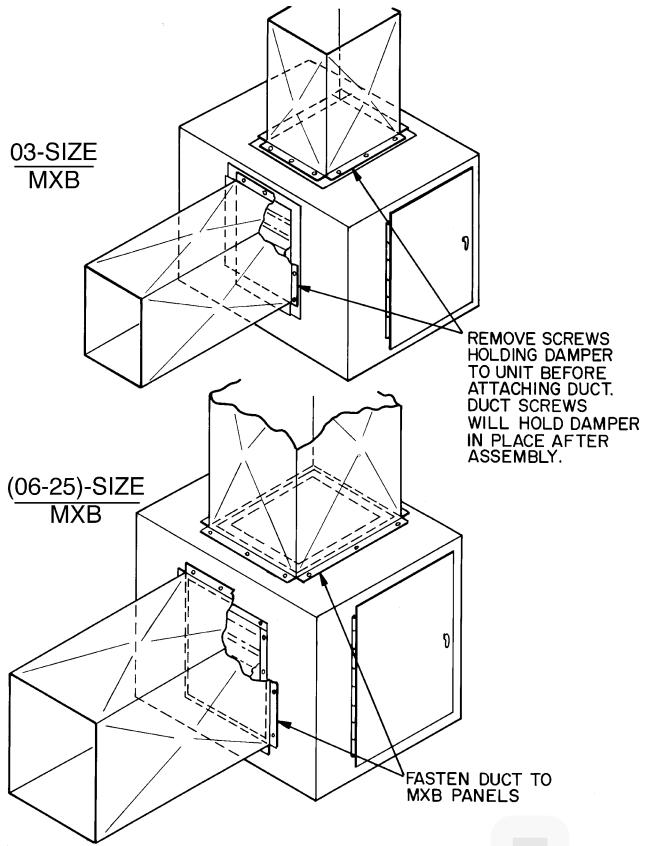

MXB — Mixing Box

**Fig. 18 — Mixing Box Ductwork Attachment**

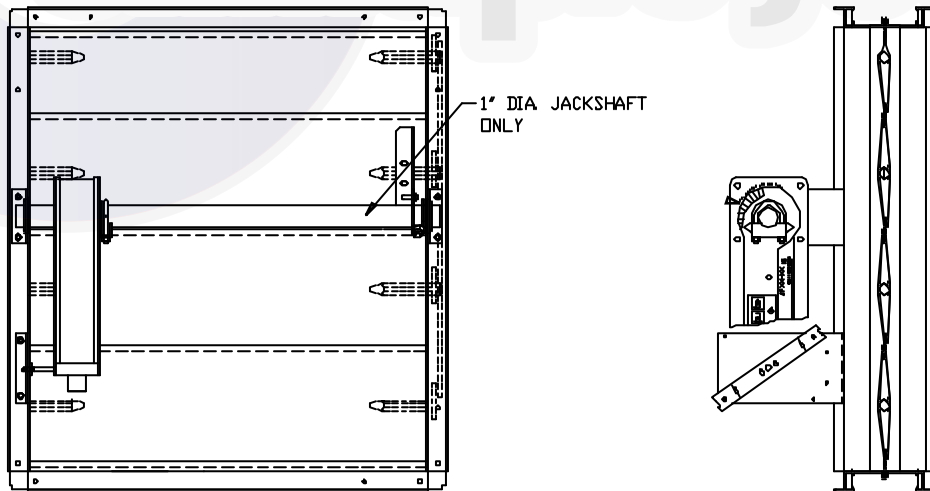

**Fig. 17 — Typical Mixing Box Actuator Mounting**

**Table 4 — Recommended Actuators**

ACCESSORY PACKAGE NO.	ACTUATOR PART NO.	VOLTAGE (50/60 Hz)	VA	ROUND SHAFT SIZE MIN-MAX (in.)	TIMING (sec)	DAMPER AREA (sq ft)		TORQUE (in.-lb)	MAXIMUM STROKE (degrees)	MAXIMUM WIRE LENGTH (ft)
						Parallel	Opposed			
33AMACTDMP133	HF27BJ035*	24	10	0.750-1.050	150	44	53	133	90	300
33AMACTGV-133	HF27BJ033	24	4	0.375-0.625	< 150	N/A	N/A	133	90	725
33AMACTGV-266	HF27BJ034	24	6	0.475-0.750	135	N/A	N/A	266	90	450

\*Actuator is spring-return type.

**NOTES:**

1. All actuators are direct coupled type, designed to be directly mounted into jackshaft assembly.
2. All actuators are equipped with a plenum rated cable, factory-terminated to the actuator. Part No. HF27BB035 and 034 are 16 ft, HF27BB033 is 9.5 ft.

3. Damper areas are nominal and based on low leakage type dampers.
4. For larger damper assemblies, multiple activators may be used.
5. Part No. HF27BB033 and 034 are designed for inlet guide vane and face and bypass applications, but may be used for external relief dampers if spring return is not required.

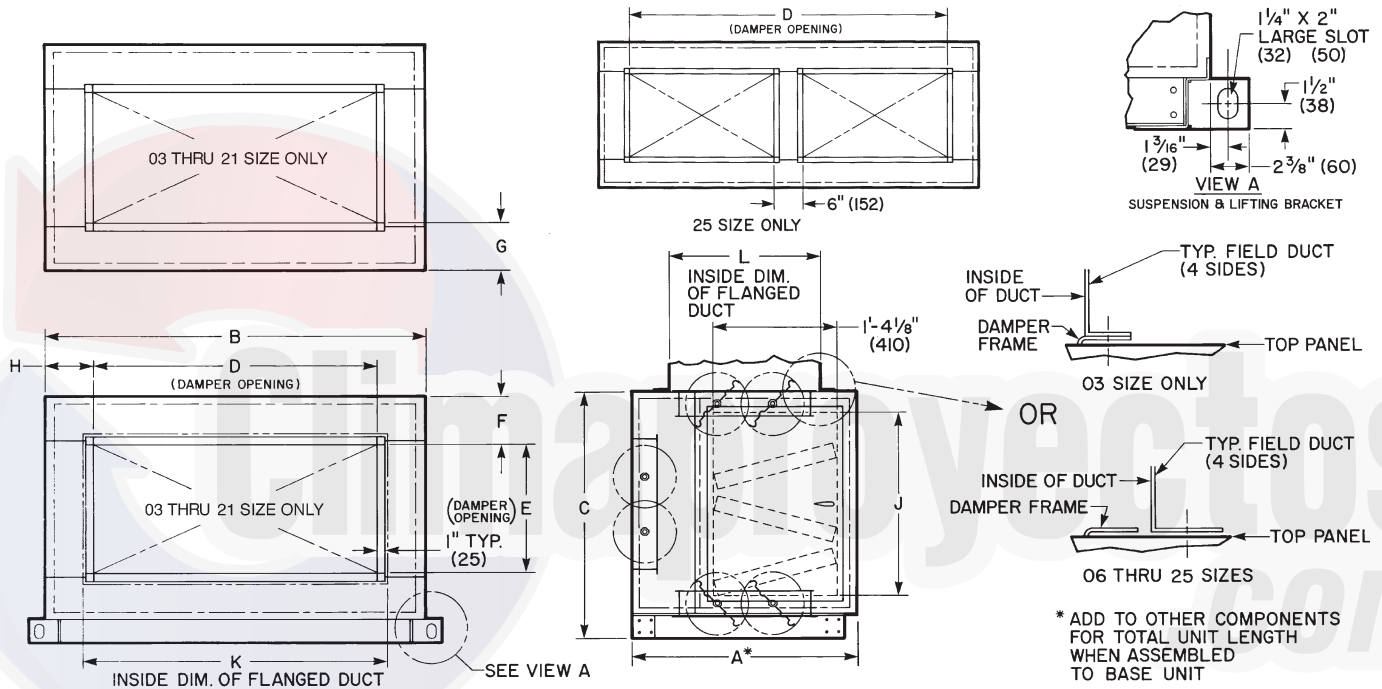

**NOTES:**

1. Hand is determined by the location of the fan drive and/or coil connection when viewed while facing the direction toward which air is flowing.
2. Dimensions are in inches, ( ) are in millimeters.

**DIMENSIONS (ft.-in.)**

UNIT 39L-	A	B	C	D	E	F	G	H	J	K	L
03	2- 3 <sup>9</sup> / <sub>16</sub>	3-1 <sup>7</sup> / <sub>8</sub>	2-0 <sup>1</sup> / <sub>4</sub>	1- 5	1-5	0- 1 <sup>5</sup> / <sub>8</sub>	0-6 <sup>1</sup> / <sub>16</sub>	0-10 <sup>1</sup> / <sub>2</sub>	1-4 <sup>3</sup> / <sub>4</sub>	1-5 <sup>1</sup> / <sub>4</sub>	1- 5 <sup>1</sup> / <sub>4</sub>
06	2- 3 <sup>9</sup> / <sub>16</sub>	3-9 <sup>3</sup> / <sub>4</sub>	2-4 <sup>3</sup> / <sub>16</sub>	1-11	1-5	0- 4 <sup>1</sup> / <sub>8</sub>	0-6 <sup>1</sup> / <sub>16</sub>	0-11 <sup>3</sup> / <sub>8</sub>	1-8 <sup>1</sup> / <sub>16</sub>	2-1 <sup>1</sup> / <sub>4</sub>	1- 7 <sup>1</sup> / <sub>4</sub>
08	2- 3 <sup>9</sup> / <sub>16</sub>	4-1 <sup>11</sup> / <sub>16</sub>	2-8 <sup>1</sup> / <sub>8</sub>	3- 1	1-5	0- 6 <sup>1</sup> / <sub>16</sub>	0-6 <sup>1</sup> / <sub>16</sub>	0- 6 <sup>3</sup> / <sub>8</sub>	2-0 <sup>5</sup> / <sub>8</sub>	3-3 <sup>1</sup> / <sub>4</sub>	1- 7 <sup>1</sup> / <sub>4</sub>
10	2- 3 <sup>9</sup> / <sub>16</sub>	4-9 <sup>9</sup> / <sub>16</sub>	2-8 <sup>1</sup> / <sub>8</sub>	3- 5	1-5	0- 6 <sup>1</sup> / <sub>16</sub>	0-6 <sup>1</sup> / <sub>16</sub>	0- 8 <sup>5</sup> / <sub>16</sub>	2-0 <sup>5</sup> / <sub>8</sub>	3-7 <sup>1</sup> / <sub>4</sub>	1- 7 <sup>1</sup> / <sub>4</sub>
12	2- 3 <sup>9</sup> / <sub>16</sub>	5-5 <sup>7</sup> / <sub>16</sub>	2-8 <sup>1</sup> / <sub>8</sub>	3-11	1-5	0- 6 <sup>1</sup> / <sub>16</sub>	0-6 <sup>1</sup> / <sub>16</sub>	0- 9 <sup>1</sup> / <sub>4</sub>	2-0 <sup>5</sup> / <sub>8</sub>	4-1 <sup>1</sup> / <sub>4</sub>	1- 7 <sup>1</sup> / <sub>4</sub>
15	2- 3 <sup>9</sup> / <sub>16</sub>	5-5 <sup>7</sup> / <sub>16</sub>	3-4	3-11	1-9	0- 8	0-4 <sup>1</sup> / <sub>16</sub>	0- 9 <sup>1</sup> / <sub>4</sub>	2-8 <sup>1</sup> / <sub>2</sub>	4-1 <sup>1</sup> / <sub>4</sub>	1-11 <sup>1</sup> / <sub>4</sub>
18	2-11 <sup>7</sup> / <sub>16</sub>	5-5 <sup>7</sup> / <sub>16</sub>	3-7 <sup>15</sup> / <sub>16</sub>	3-11	2-3	0- 7	0-5	0- 9 <sup>1</sup> / <sub>4</sub>	3-0 <sup>7</sup> / <sub>16</sub>	4-1 <sup>1</sup> / <sub>4</sub>	2- 5 <sup>1</sup> / <sub>4</sub>
21	2-11 <sup>7</sup> / <sub>16</sub>	6-5 <sup>1</sup> / <sub>4</sub>	3-7 <sup>15</sup> / <sub>16</sub>	3-11	2-5	0- 6	0-4	1- 3 <sup>1</sup> / <sub>8</sub>	3-0 <sup>7</sup> / <sub>16</sub>	4-1 <sup>1</sup> / <sub>4</sub>	2- 7 <sup>1</sup> / <sub>4</sub>
25	2-11 <sup>7</sup> / <sub>16</sub>	6-5 <sup>1</sup> / <sub>4</sub>	4-3 <sup>13</sup> / <sub>16</sub>	5- 4	2-5	0- 9 <sup>7</sup> / <sub>8</sub>	0-4	0- 6 <sup>5</sup> / <sub>8</sub>	3-8 <sup>5</sup> / <sub>16</sub>	5-6 <sup>1</sup> / <sub>4</sub>	2- 7 <sup>1</sup> / <sub>4</sub>

**Fig. 19 — Mixing Box Duct Connections**

**Condensate Drain** — Install a trapped condensate drain line at unit drain connection. Use 1-in. standard pipe.

Measure maximum design negative static pressure upstream from the fan. Referring to Fig. 20, height “H” must be equal to or larger than negative static pressure at design operating conditions. Prime enough water in trap to prevent losing seal (Differential 1). When the fan starts, Differential 2 is equal to the maximum negative static pressure.

Provide freeze-up protection and insulation as required.

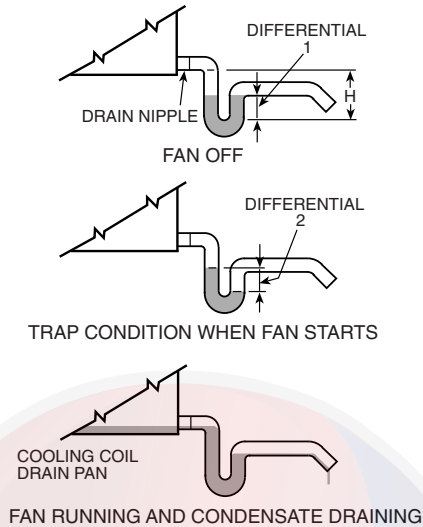

**Fig. 20 — Condensate Drain**

**Variable Frequency Drive (VFD)** — Variable frequency drives (VFDs) are used to modulate fan motor speed in response to air volume requirements. To vary the motor speed, a VFD changes the input frequency and line voltage into a wide range of frequency and voltage outputs, while maintaining a constant ratio of frequency to voltage.

Since 2001, all 1-hp and greater motors supplied by Carrier for the 39L series air handling units are designed and constructed for use with variable frequency drives. If a field-supplied motor is installed, ensure the motor is suitable for use with a VFD.

If the lead length from the VFD to the motor is greater than 25 ft, Shaft Grounding Rings (SGR) are necessary to help dissipate induced shaft voltages to ground and prevent motor bearing damage.

**Install Fan Motor** — For field installation of motors, be sure electrical junction box is toward the center of the unit. This is necessary for drive and belts to be properly tightened. Use smallest slots in motor mounting base that will accommodate motor and allow minimum overhang (Fig. 21). Be sure that motor holddown bolts are tight on field-installed motor.

**JUNCTION BOX CONDENSATE PREVENTION** —

When air handlers are installed outdoors in a high humidity environment or indoors where the apparatus room is used as a fresh air plenum, precautions must be taken to prevent condensation from forming inside the junction box of the internally mounted motor.

Standard installation practice is to mount the motor starter or fused disconnect box adjacent to the air handler and enclose the power wiring to the motor in flexible conduit.

The sheet metal housing of the disconnect switch or motor starter is not airtight (even when a box meeting NEMA [National Electrical Manufacturers Association] IV standards is used). Thus, warm moist air can migrate through the flexible conduit to the junction box on the motor. With the motor located inside the unit, the motor temperature is that of the cool

supply air; thus, condensate can form inside the junction box and, possibly, on the live terminal lugs.

To prevent the moist air from migrating through the conduit to the motor, seal the power wires inside the flexible conduit at the motor starter or fused disconnect.

Use a nonconductive, nonhardening sealant. Permagum (manufactured by Schnee Morehead) or sealing compound, thumb grade (manufactured by Calgon), are acceptable materials.

**POWER KNOCKOUTS** — Panels are not provided with knockouts for the fan motor power wiring. Openings must be drilled or punched in the exterior panels of the unit. It is recommended that power wiring be routed through the discharge panel whenever possible, as this panel is rarely removed for service access.

**Install Sheaves on Motor and Fan Shafts** —

Factory-supplied drives are prealigned and tensioned, however, Carrier recommends that you check the belt tension and alignment before starting the unit. Always check the drive alignment after adjusting belt tension.

When field installing or replacing sheaves, install sheaves on fan shaft and motor shaft for minimum overhang. (See Fig. 21.) Use care when mounting sheave on fan shaft; too much force may damage bearing. Remove rust-preventative coating or oil from shaft. Make sure shaft is clean and free of burrs. Add grease or lubricant to bore of sheave before installing.

The 39L fan, shaft, and drive pulley are balanced as a complete assembly to a high degree of accuracy. If excessive unit vibration is present after fan pulley replacement, the unit must be rebalanced. For drive ratio changes, always reselect the motor pulley — do not change the fan pulley.

**ALIGNMENT** — Make sure that fan shafts and motor shafts are parallel and level. The most common causes of misalignment are nonparallel shafts and improperly located sheaves. Where shafts are not parallel, belts on one side are drawn tighter and pull more than their share of the load. As a result, these belts wear out faster, requiring the entire set to be replaced before it has given maximum service. If misalignment is in the sheave, belts will enter and leave the grooves at an angle, causing excessive belt cover and sheave wear.

1. Shaft alignment can be checked by measuring the distance between the shafts at 3 or more locations. If the distances are equal, then the shafts will be parallel.
2. Sheave alignment:

**Fixed sheaves** — To check the location of the fixed sheaves on the shafts, a straightedge or a piece of string can be used. If the sheaves are properly lined up the string will touch them at the points indicated by the arrows in Fig. 22.

**Adjustable sheave** — To check the location of adjustable sheave on shaft, make sure that the centerlines of both sheaves are in line and parallel with the bearing support channel. See Fig. 22. Adjustable pitch drives are installed on the motor shaft.

**⚠ CAUTION**

With adjustable sheave, do not exceed maximum fan rpm.

3. Rotating each sheave a half revolution will determine whether the sheave is wobbly or the drive shaft is bent. Correct any misalignment.



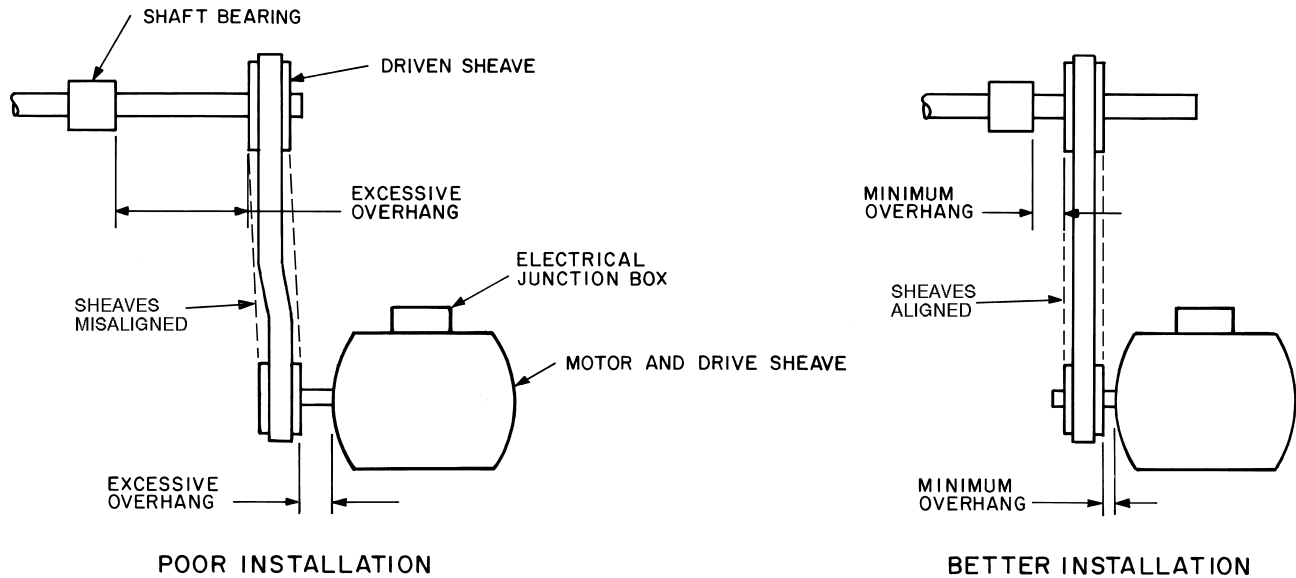

**Fig. 21 — Determining Sheave-Shaft Overhang**

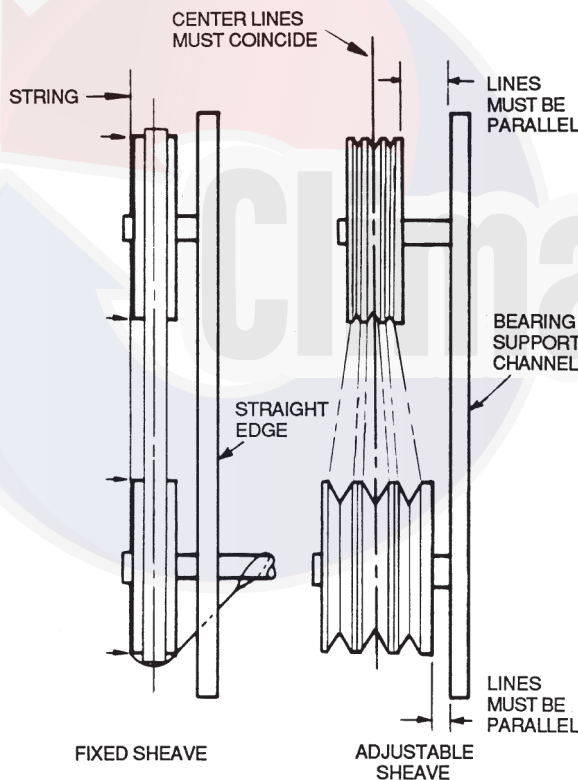

**Fig. 22 — Sheave Alignment**

4. With sheaves aligned, tighten cap screws evenly and progressively.

NOTE: There should be a 1/8-in. to 1/4-in. gap between the mating part hub and the bushing flange. If gap is closed, the bushing is probably the wrong size.

5. With taper-lock bushed hubs, be sure the bushing bolts are tightened evenly to prevent side-to-side pulley wobble. Check by rotating sheaves and rechecking sheave alignment. When substituting field-supplied sheaves for factory-supplied sheaves, consider that the fan shaft sheave has been factory balanced with fan and shaft as an assembly. For this

reason, substitution of motor sheave is preferable for final speed adjustment.

**Install V-Belts** — *When installing or replacing belts, always use a complete set of new belts.* Mixing old and new belts will result in the premature wear or breakage of the newer belts.

Refer to label on inside of fan access door for information on factory-supplied drive.

1. Always adjust the motor position so that V-belts can be installed without stretching over grooves. Forcing belts can result in uneven stretching and a mismatched set of belts.
2. **Do not allow belt to bottom out in sheave.**
3. Tighten belts by turning motor-adjusting jackscrews. Turn each jackscrew an equal number of turns.
4. Equalize belt slack so that it is on the same side of belt for all belts. Failure to do so may result in uneven belt stretching.
5. Tension new drives at the maximum deflection force recommended (Table 5).

On current production, the correct tension information is listed on the fan drive label. For older equipment or units with field-modified drives, use the deflection formula in the following example and the tension data from Table 5.

EXAMPLE:

**Given**

Belt Span	16 in.
Belt Cross-Section A, Super Belt	
Small Sheave PD	5 in.

$$\text{Deflection} = \frac{(\text{Belt Span})}{64}$$

**Solution**

- a. From Table 5 find that deflection force for a new type A, super belt with 5-in. small sheave PD is 8 lb.
- b.

$$\text{Deflection} = \frac{16}{64}$$

Tension Measurement Procedure

1. Measure the belt span (see Fig. 23).
2. Position bottom of the large O-ring on the span scale at the measured belt span.

3. Set the small O-ring on the deflection force scale to zero.
4. Place the tension checker squarely on one belt at the center of the belt span. Apply a force on the plunger and perpendicular to the belt span until the bottom of the large O-ring is even with the top of the adjacent (next) belt or with the bottom of a straight edge laid across the outside diameters of the v-belt sheaves.
5. Remove the tension checker and read the force applied from the bottom of the small O-ring on the deflection force scale.
6. Compare the force you have applied with the values given in Table 5. The force should be between the "Used Belt" and "New Belt" values shown. The maximum value is shown for "New Belt" and new belts should be tensioned at this value to allow for expected tension loss. "New Belt" tensions should be used at initial installation

and after job start or 1 to 3 minutes of operation. Used belts should be maintained at the value as indicated in the chart. "Used Belt" tensions should be used for the 8-hour and subsequent checks. If the belt span was measured in centimeters, then use the kilograms of force values for comparison.

NOTE: The ratio of deflection to belt span is 1:64 in either unit of measurement.

Whenever possible, jog start for a few revolutions or preferably run drive for approximately 1 to 3 minutes and then re-tension in accordance with Steps 1-6. Running the drive for a few revolutions or minutes will help seat the belt(s) in the groove(s). This relatively early re-tensioning may reduce or minimize the amount of re-tensioning required in the first 24 hours of drive service. Record information on the label (Fig. 24) found on the door of the fan section.

**Table 5 — Fan Belt Tension Data**

SHEAVE DIAMETER (in.) DEFLECTION FORCE (lb)						
BELT STYLE	SMALLEST SHEAVE DIAMETER RANGE	RPM RANGE	BELT DEFLECTION FORCE			
			SUPER GRIPBELTS AND UNNOTCHED GRIPBANDS		GRIPNOTCH BELTS AND NOTCHED GRIPBANDS	
			USED BELT	NEW BELT	USED BELT	NEW BELT
A, AX	3.0 - 3.6	1000-2500	3.7	5.5	4.1	6.1
		2501-4000	2.8	4.2	3.4	5.0
	3.8 - 4.8	1000-2500	4.5	6.8	5.0	7.4
		2501-4000	3.8	5.7	4.3	6.4
	5.0 - 7.0	1000-2500	5.4	8.0	5.7	8.4
		2501-4000	4.7	7.0	5.1	7.6
B, BX	3.4 - 4.2	860-2500	—	—	4.9	7.2
		2501-4000	—	—	4.2	6.2
	4.4 - 5.6	860-2500	5.3	7.9	7.1	10.5
		2501-4000	4.5	6.7	6.1	9.1
	5.8 - 8.6	860-2500	6.3	9.4	8.5	12.6
		2501-4000	6.0	8.9	7.3	10.9
C, CX	7.0 - 9.0	500-1740	11.5	17.0	14.7	21.8
		1741-3000	9.4	13.8	11.9	17.5
	9.5 - 16.0	500-1740	14.1	21.0	15.9	23.5
		1741-3000	12.5	18.5	14.6	21.6
D	12.0 - 16.0	200-850	24.9	37.0	—	—
		851-1500	21.2	31.3	—	—
	18.0 - 20.0	200-850	30.4	45.2	—	—
		851-1500	25.6	38.0	—	—
3V, 3VX	2.2 - 2.4	1000-2500	—	—	3.3	4.9
		2501-4000	—	—	2.9	4.3
	2.65 - 3.65	1000-2500	3.6	5.1	4.2	6.2
		2501-4000	3.0	4.4	3.8	5.6
	4.12 - 6.90	1000-2500	4.9	7.3	5.3	7.9
		2501-4000	4.4	6.6	4.9	7.3
5V, 5VX	4.4 - 6.7	500-1749	—	—	10.2	15.2
		1750-3000	—	—	8.8	13.2
		3001-4000	—	—	5.6	8.5
	7.1 - 10.9	500-1749	12.7	18.9	14.8	22.1
		1750-3000	11.2	16.7	13.7	20.1
		3001-4000	—	—	—	—
	11.8 - 16.0	500-1749	15.5	23.4	17.1	25.5
		1750-3000	14.6	21.8	16.8	25.0
		3001-4000	—	—	—	—
8V	12.5 - 17.0	200-850	33.0	49.3	—	—
		851-1500	26.8	39.9	—	—
	18.0 - 22.4	200-850	39.6	59.2	—	—
		851-1500	35.3	52.7	—	—

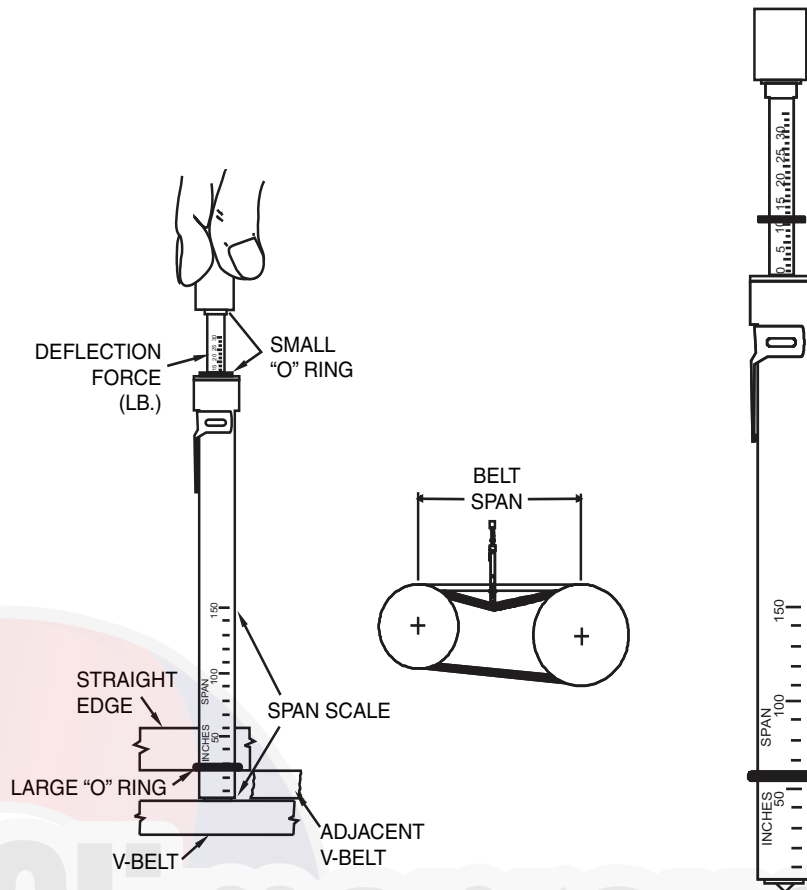

Fig. 23 — Fan Belt Tension

**Water and Steam Coil Piping Recommendations**

GENERAL — Use straps around the coil casing or the lifting holes (see Fig. 25) to lift and place the coil.

**CAUTION**

To prevent damage to the coil or coil headers: Do not use the headers to lift the coil. Support the piping and coil connections independently. Do not use the coil connections to support piping. When tightening coil connections, use a backup wrench on the nozzles.

Piping practices are outlined in the Carrier System Design Manual, Part 3, Piping Design. See Tables 6-7 for circuiting data.

**WATER COILS** — Typically, coils are piped by connecting the supply at the bottom and the return at the top. See Fig. 25. This is not always the case, especially if the coil hand has been changed in the field. Coils must be piped for counterflow; otherwise, a capacity reduction of 5% for each coil row will result. To ensure counterflow, chilled water coils are piped so that the coldest water meets the coldest air. Hot water coils are piped so that the warmest water meets the warmest air.

**STEAM COILS** — Position the steam supply connection at the top of the coil, and the return (condensate) connection at the bottom. The coil tubes must incline downwards toward the return header connection for condensate drainage. See Fig. 26-30 and Table 8.

Figure 26 illustrates the normal piping components and the suggested locations for high, medium, or low-pressure steam coils. The low-pressure application (zero to 15 psig) can dispense with the 1/4-in. petcock for continuous venting located above the vacuum breaker (check valve).

**NOTICE**

TENSION BELTS TO SPECIFICATION SHOWN ON DRIVE LABEL. OVER TENSIONING BELTS WILL SEVERELY REDUCE BELT AND BEARING LIFE.

**REPLACEMENT PARTS**

**BEARINGS**

DRIVE \_\_\_\_\_

FREE \_\_\_\_\_

SHAFT \_\_\_\_\_

WHEEL \_\_\_\_\_

INLET CONE \_\_\_\_\_

TO ORDER REPLACEMENT PARTS,  
CONTACT: RCD  
(REPLACEMENT COMPONENTS DIVISION)  
1-800-443-4410

Fig. 24 — Fan Section Label

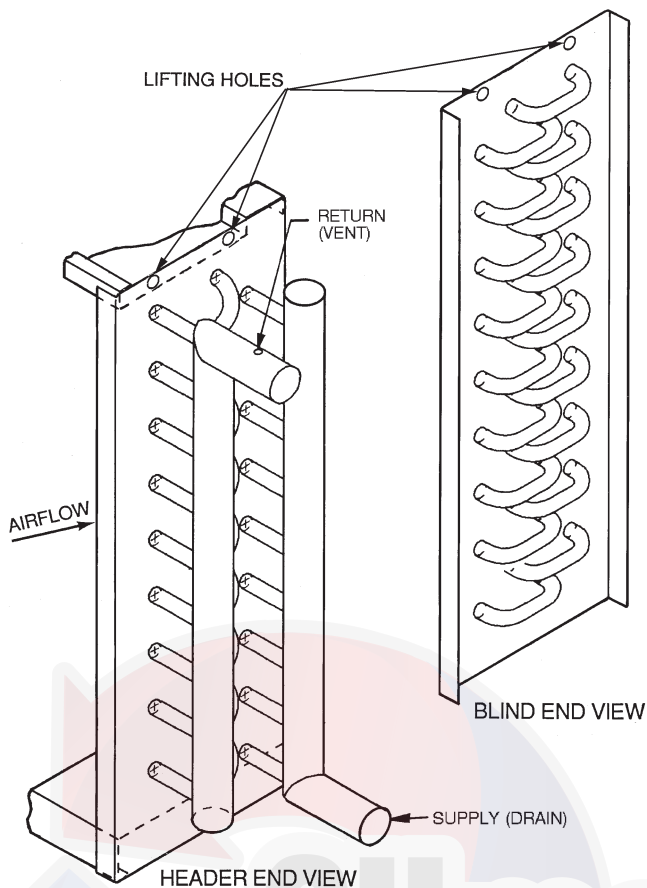

**Fig. 25 — Coil Connections and Lifting Points**

Note the horizontal location of the 15-degree check valve, and the orientation of the gate/pivot. This valve is intended to relieve any vacuum forming in the condensate outlet of a condensing steam coil, and to seal this port when steam pressure is again supplied to the coil. It must not be installed in any other position, and should not be used in the supply line.

For coils used in tempering service, or to preheat outside air, install an immersion thermostat in the condensate line ahead of the trap. This will shut down the supply fan and close the outdoor damper whenever the condensate falls to a predetermined point, perhaps 120 F.

NOTE: Do NOT use an immersion thermostat to override a duct thermostat and open the steam supply valve.

For vacuum return systems, the vacuum breaking check valve would be piped into the condensate line between the trap and the gate valve instead of open to the atmosphere.

Figure 27 illustrates the typical piping at the end of every steam supply main. Omitting this causes many field problems and failed coils.

Figure 28 shows the typical field piping of multiple coils. Use this only if the coils are the same size and have the same pressure drop. If this is not the case, an individual trap must be provided for each coil.

Figure 29 shows a multiple coil arrangement applied to a gravity return, including the open air relief to the atmosphere, which DOES NOT replace the vacuum breakers.

Figure 30 illustrates the basic condensate lift piping.

Following the piping diagrams in Fig. 26-30, make all connections while observing the following precautions:

- Install a drip line and trap on the pressure side of the inlet control valve. Connect the drip line to the return line downstream of the return line trap.
- To prevent scale or foreign matter from entering the control valve and coil, install a  $\frac{3}{32}$ -in. mesh strainer in the steam supply line upstream from the control valve.
- Provide air vents for the coils to eliminate noncondensable gases.
- Select a control valve according to the steam load, not the coils supply connection size. Do not use an oversized control valve.
- Do not use bushings that reduce the size of the header return connection. The return connection should be the same size as the return line and reduced only at the downstream trap.
- To lift condensate above the coil return line into overhead steam mains, or pressurized mains, install a pump and receiver between the condensate trap and the pressurized main. Do not try to lift condensate with modulating or on-and-off steam control valves. Use only 15-degree check valves, as they open with a lower water head. Do not use 45-degree or vertical-lift check valves.
- Use float and thermostatic traps. Select the trap size according to the pressure difference between the steam supply main and the return main.
- Load variations can be caused by uneven inlet air distribution or temperature stratification.
- Drain condensate out of coils completely at the end of the heating season to prevent the formation of acid.

**Table 6 — Hot Water Coil Circuiting Data**

39L UNIT SIZE		03	06	08	10	12	15	18	21	25
		No. of Circuits								
1-ROW	H	6	8	10	10	10	13	15	15	13
2-ROW	H	6	8	10	10	10	13	15	15	13
	F	12	16	20	20	20	26	30	30	36

**LEGEND**

- F — Full Circuit
- H — Half Circuit

NOTE: All hot water coils have 1 1/2-in. MPT.

**Table 7 — Chilled Water Coil Circuiting Data**

LARGE FACE AREA (39LA, 39LD)											
COIL TYPE	CIRCUIT	UNIT SIZE									
		03		06		08		10		12	
		Face Area (sq ft)									
		3.63		5.90		7.90		9.54		11.18	
No. Circuits	Connection Size	No. Circuits	Connection Size	No. Circuits	Connection Size	No. Circuits	Connection Size	No. Circuits	Connection Size		
4-ROW	Q	4	1 1/2	5	1 1/2	—	—	—	—	—	—
	H	8	1 1/2	10	1 1/2	12	1 1/2	12	1 1/2	12	1 1/2
	F	16	1 1/2	20	1 1/2	24	2 1/2	24	2 1/2	24	2 1/2
6-ROW	H	8	1 1/2	10	1 1/2	12	1 1/2	12	1 1/2	12	1 1/2
	F	16	1 1/2	20	1 1/2	24	2 1/2	24	2 1/2	24	2 1/2
	D	—	—	—	—	36	2 1/2	36	2 1/2	36	2 1/2

LARGE FACE AREA (39LA, 39LD)									
COIL TYPE	CIRCUIT	UNIT SIZE							
		15		18		21		25	
		Face Area (sq ft)							
		14.91		17.71		21.60		25.00	
No. Circuits	Connection Size	No. Circuits	Connection Size	No. Circuits	Connection Size	No. Circuits	Connection Size		
4-ROW	Q	—	—	—	—	—	—	—	—
	H	16	1 1/2	19	1 1/2	19	1 1/2	22	1 1/2
	F	32	2 1/2	38	2 1/2	38	2 1/2	44	2 1/2
6-ROW	H	16	1 1/2	19	1 1/2	19	1 1/2	—	—
	F	32	2 1/2	38	2 1/2	38	2 1/2	44	2 1/2
	D	48	2 1/2	57	2 1/2	57	2 1/2	66	2 1/2

**LEGEND**  
**D** — Double Circuit  
**F** — Full Circuit  
**H** — Half Circuit  
**Q** — Quarter Circuit

**NOTES:**  
 1. Connection sizes are MPT — inches.  
 2. Sizes 21-25 have 2 coils.

**Table 7 — Chilled Water Coil Circuiting Data (cont)**

SMALL FACE AREA (39LB, 39LC, 39LF)											
COIL TYPE	CIRCUITING	UNIT SIZE									
		03		06		08		10		12	
		Face Area (sq ft)									
		2.72		4.72		6.58		7.95		9.23	
No. Circuits	Connection Size	No. Circuits	Connection Size	No. Circuits	Connection Size	No. Circuits	Connection Size	No. Circuits	Connection Size		
4-ROW	Q	3	1 1/2	4	1 1/2	—	—	—	—	—	—
	H	6	1 1/2	8	1 1/2	10	1 1/2	10	1 1/2	10	1 1/2
	F	12	1 1/2	16	1 1/2	20	2 1/2	20	2 1/2	20	2 1/2
6-ROW	H	6	1 1/2	8	1 1/2	10	1 1/2	10	1 1/2	10	1 1/2
	F	12	1 1/2	16	1 1/2	20	2 1/2	20	2 1/2	20	2 1/2
	D	—	—	—	—	30	2 1/2	30	2 1/2	30	2 1/2
8-ROW*	H	6	1 1/2	8	1 1/2	10	1 1/2	10	1 1/2	10	1 1/2
	F	12	1 1/2	16	1 1/2	20	2 1/2	20	2 1/2	20	2 1/2
	D	—	—	—	—	40	2 1/2	40	2 1/2	40	2 1/2

SMALL FACE AREA (39LB, 39LC, 39LF)									
COIL TYPE	CIRCUITING	UNIT SIZE							
		15		18		21		25	
		Face Area (sq ft)							
		12.12		13.98		17.10		20.50	
No. Circuits	Connection Size	No. Circuits	Connection Size	No. Circuits	Connection Size	No. Circuits	Connection Size		
4-ROW	Q	—	—	—	—	—	—	—	—
	H	13	1 1/2	15	1 1/2	15	1 1/2	18	1 1/2
	F	26	2 1/2	30	2 1/2	30	2 1/2	36	2 1/2
6-ROW	H	13	1 1/2	15	1 1/2	15	1 1/2	—	—
	F	26	2 1/2	30	2 1/2	30	2 1/2	36	2 1/2
	D	39	2 1/2	45	2 1/2	45	2 1/2	54	2 1/2
8-ROW*	H	13	1 1/2	13	1 1/2	—	—	—	—
	F	26	2 1/2	30	2 1/2	30	2 1/2	36	2 1/2
	D	52	2 1/2	60	2 1/2	60	2 1/2	72	2 1/2

**LEGEND**  
**D** — Double Circuit  
**F** — Full Circuit  
**H** — Half Circuit  
**Q** — Quarter Circuit

\*Not available on 39LB units.  
 NOTE: Connection sizes are MPT - inches.

**Table 8 — Steam Coil Connection Sizes**

39L UNIT SIZE	FACE AREA	COIL TYPE	CIRCUITING	CONNECTION	CONNECTION SIZE
03-25	Small	1-Row	F	Inlet	2 <sup>1</sup> / <sub>2</sub>
				Outlet	1 <sup>1</sup> / <sub>2</sub>

**LEGEND**

F — Full Circuit

NOTE: Connection sizes are MPT - inches.

**Coil Freeze-Up Protection**

**WATER COILS** — If a chilled water coil is applied with outside air, provisions must be made to prevent coil freeze-up. Install a coil freeze-up thermostat to shut down the system if any air temperature below 36 F is encountered entering the water coil. Follow thermostat manufacturer’s instructions.

When a water coil is applied downstream of a direct-expansion (DX) coil, a freeze-up thermostat must be installed between the DX and water coil and electrically interlocked to turn off the cooling to prevent freeze-up of the water coil.

For outdoor-air application where intermittent chilled water coil operation is possible, one of the following steps should be taken:

- Install an auxiliary blower heater in cabinet to maintain above-freezing temperature around coil while unit is shut down.
- Drain coils and fill with an ethylene glycol solution suitable for the expected cold weather operation. Shut down the system and drain coils. See Service section, Winter Shutdown, page 36.

**STEAM COILS** — When used for preheating outdoor air in pressure or vacuum systems, an immersion thermostat to control outdoor-air damper and fan motor is recommended. This control is actuated when steam supply fails or condensate temperature drops below an established level, such as 120 to 150 F. A vacuum breaker should also be used to equalize coil pressure with the atmosphere when steam supply throttles close. Steam should not be modulated when outdoor air is below 40 F.

On low-pressure and vacuum steam-heating systems, the thermostat may be replaced by a condensate drain with a thermal element. This element opens and drains the coil when condensate temperature drops below 165 F. Note that condensate drains are limited to 5 psig pressure.

**INNER DISTRIBUTING TUBE STEAM COILS** — The inner distributing tube (IDT) steam coil used in the Carrier 39L air-handling units has an inner tube pierced to facilitate the distribution of the steam along the tube’s length. The outer tubes are expanded into plate fins. The completed assembly includes the supply and condensate header and side casings which are built to slant the fin/tube bundle back toward the condensate header. The slanting of the assembly ensures that condensate will flow toward the drains. This condensate must be removed through the return piping to prevent premature failure of the coil. The fin/tube bundle is slanted vertically for horizontal air-flow coils, and horizontally for vertical air-flow coils.

**IDT Steam Coil Piping** — The following piping guidelines will contribute to efficient coil operation and long coil life:

1. Use full size coil outlets and return piping to the steam trap. Do not bush return outlet to the coil. Run full size to the trap, reduce at the trap.
2. Use float and thermostatic traps only for condensate removal. Trap size selection should be based on the difference in pressure between the steam supply main and the

condensate return main. It is good practice to select a trap with 3 times the condensate rating of the coil to which it is connected.

3. Use thermostatic traps for venting only.
4. Use only 1/2-in., 15-degree swing check valves installed horizontally, piped open to atmosphere, and located at least 12 in. above the condensate outlet. Do not use 45-degree, vertical lift and ring check valves.
5. The supply valve must be sized for the maximum anticipated steam load.
6. Do not drip steam mains into coil sections. Drip them on the pressure side of the control valve and trap them into the return main beyond the trap for the coil.
7. Do not use a single trap for two or more coils installed in series. Where two or more coils are installed in a single bank, in parallel, the use of a single trap is permissible, but only if the load on each coil is equal. Where loads in the same coil bank vary, best practice is to use a separate trap for each coil.

Variation in load on different coils in the same bank may be caused by several factors. Two of the most common are uneven airflow distribution across the coil and stratification of inlet air across the coil.

8. Do not try to lift condensate above the coil return into an overhead main, or drain into a main under pressure with a modulating or on/off steam control valves. A pump and receiver should be installed between the coil condensate traps and overhead mains and return mains under pressure.
9. Use a strainer (3/32-in. mesh) on the steam supply side, as shown in the piping diagrams, to avoid collection of scale or other foreign matter in the inner tube distributing orifices.

NOTE: IDT coils must be installed with the tubes draining toward the header end of the coil. Carrier’s IDT steam coils are pitched toward the header end as installed in the unit.

10. Ensure the AHU (air-handling unit) is installed level to maintain the inherent slope. Also ensure the unit is installed high enough to allow the piping to be installed correctly, especially the traps which require long drip legs.
11. Do not fail to provide all coils with the proper air vents to eliminate noncondensable gasses.
12. Do not support steam piping from the coil units. Both mains and coil sections should be supported separately.

**IDT Steam Coil Installation** — Refer to drawings to position the coils properly with regard to the location of the supply and return connections. Ensure that the IDT coil is pitched with the tubes draining toward the header. Carrier’s AHUs provide proper coil pitch when the AHU is installed level.

Refer to schematic piping diagrams and piping connection notes for the recommended piping methods.

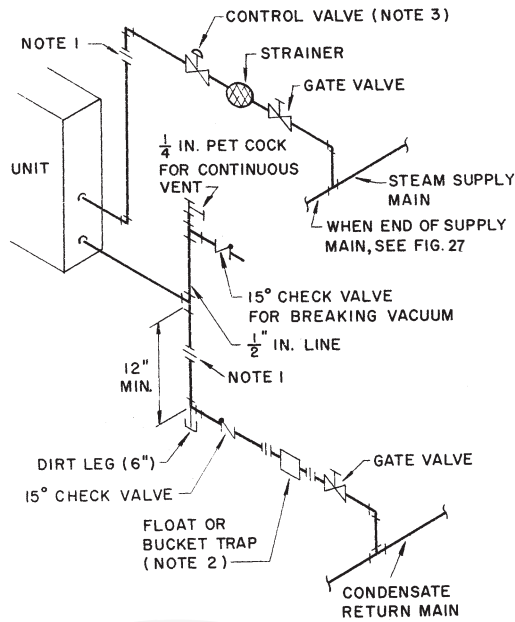

**NOTES:**

1. Flange or union is located to facilitate coil removal.
2. Flash trap may be used if pressure differential between steam and condensate return exceeds 5 psi.
3. When a bypass with control is required.
4. Dirt leg may be replaced with a strainer. If so, tee on drop can be replaced by a reducing ell.
5. The petcock is not necessary with a bucket trap or any trap which has provision for passing air. The great majority of high or medium pressure returns end in hot wells or deaerators which vent the air.

**Fig. 26 — Low, Medium or High Pressure Coil Piping**

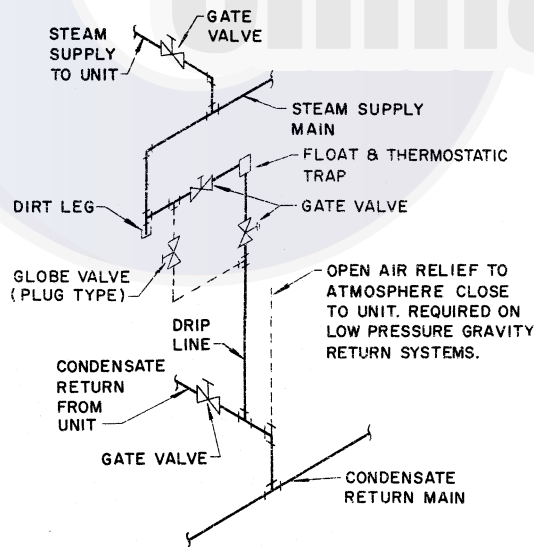

**NOTES:**

1. A bypass is necessary around trap and valves when continuous operation is necessary.
2. Bypass to be the same size as trap orifice but never less than 1/2 inch.

**Fig. 27 — Dripping Steam Supply to Condensate Return**

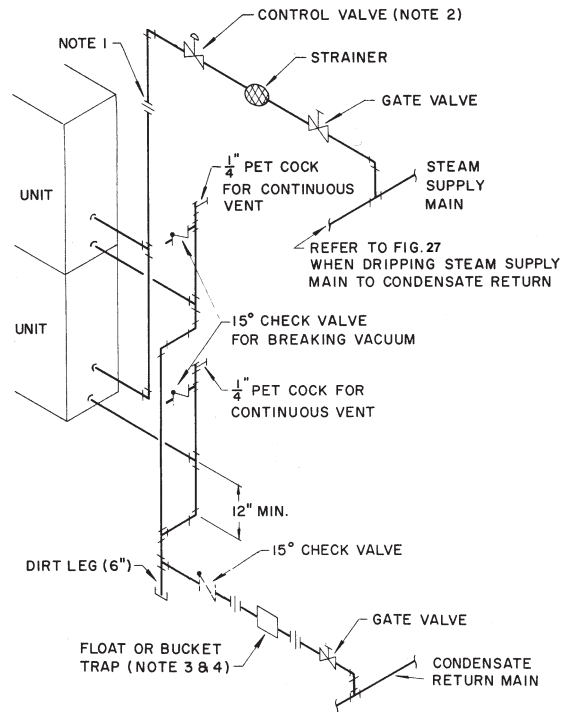

**NOTES:**

1. Flange or union is located to facilitate coil removal.
2. When a bypass with control is required.
3. Flash trap can be used if pressure differential between supply and condensate return exceeds 5 psi.
4. Coils with different pressure drops require individual traps. This is often caused by varying air velocities across the coil bank.
5. Dirt leg may be replaced with a strainer. If so, tee on drop can be replaced by a reducing ell.
6. The petcock is not necessary with a bucket trap or any trap which has provision for passing air. The great majority of high pressure return mains terminate in hot wells or deaerators which vent the air.

**Fig. 28 — Multiple Coil High Pressure Piping**

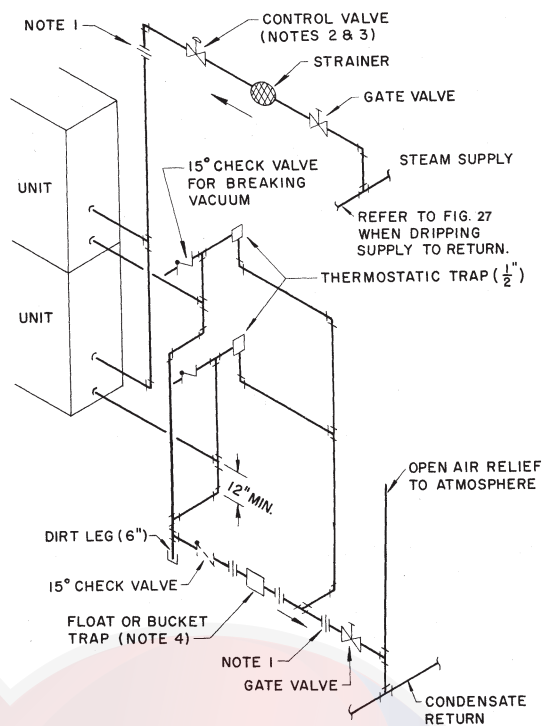

**NOTES:**

1. Flange or union is located to facilitate coil removal.
2. When control valve is omitted on multiple coils in parallel air flow.
3. When a bypass with control is required.
4. Coils with different pressure drops require individual traps. This is often caused by varying air velocities across the coil bank.

**Fig. 29 — Multiple Coil Low Pressure Piping Gravity Return**

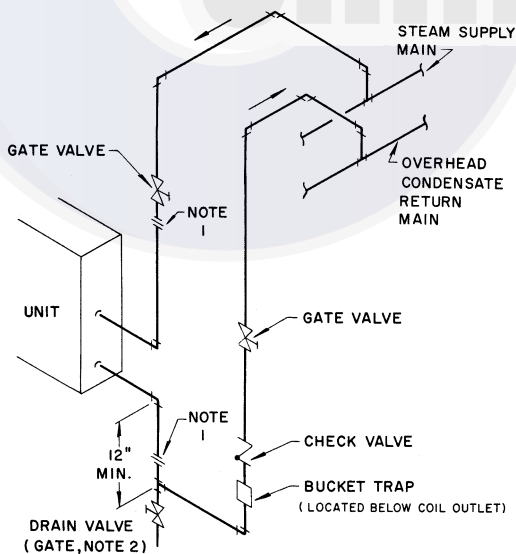

**NOTES:**

1. Flange or union is located to facilitate coil removal.
2. To prevent water hammer, drain coil before admitting steam.
3. Do not exceed one foot of lift between trap discharge and return main for each pound of pressure differential.
4. Do not use this arrangement for units handling outside air.

**Fig. 30 — Condensate Lift to Overhead Return**

**Refrigerant Piping, Direct-Expansion (DX) Coils (Fig. 31)** — Direct-expansion coils are divided into 2 or 4 splits depending upon the unit size and coil circuiting. See Table 9 for coil circuiting data. Each split requires its own distributor nozzle, expansion valve, and suction piping. Suction connections are on the air entering side when the coil is properly installed. Matching distributor connections for each coil split are on the air leaving side. See unit label or certified drawing to assure connection to matching suction and liquid connections. See Table 10 for distributor part numbers.

**CAUTION**

Direct-expansion coils are shipped pressurized with dry air. Release pressure from each coil split through valves in protective caps before removing caps.

Do not leave piping open to the atmosphere unnecessarily. Water and water vapor are detrimental to the refrigerant system. Until the piping is complete, recap the system and charge with nitrogen at the end of each workday. Clean all piping connections before soldering joints.

The lower split of face split coils should be *first on, last off*.

Row split coils utilize special intertwined circuits (as shown in Fig. 31); either split of these row split coils can be *first on, last off*.

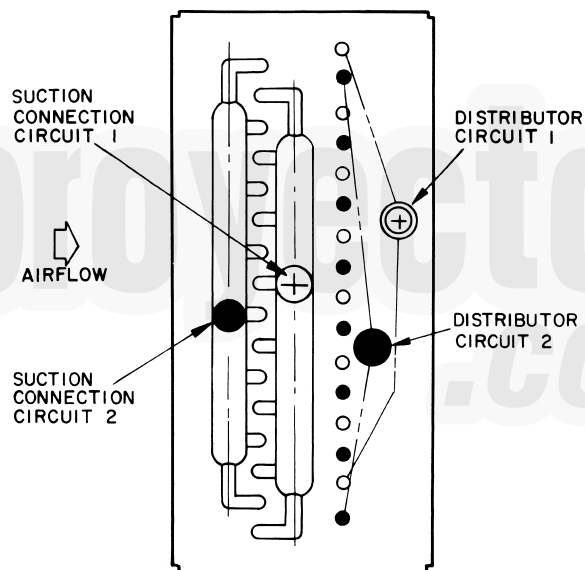

**Fig. 31 — Typical Direct-Expansion Row Split Coil**



**SUCTION PIPING** — Connect suction piping as shown in Fig. 32 for face split coil or Fig. 33 for row split coil.

Suction line from coil connection to end of the 15-diameter-long riser should be same tube size as coil connection to ensure proper refrigerant velocity.

Refer to Carrier System Design Manual, Part 3, and size remaining suction line to compressor for a pressure drop equivalent to 2.0 F. This will provide a total suction line header pressure drop equivalent to approximately 2.5 F. Refer to Fig. 34 for piping risers to the compressor.

To minimize the possibility of flooded starts and compressor damage during prolonged light load operation, install an accumulator in the suction line or a solenoid in the liquid line of *last-on, first off* split in row-split applications.

**EXPANSION VALVE PIPING** — Distributor nozzles sized for acceptable performance for a range of conditions are factory supplied. Use the AHU (Air-Handling Unit) selection program in the Carrier electronic catalog to select optimal nozzle sizes. Replace factory nozzle as necessary for best performance. See Fig. 35.

Thermostatic expansion valves are field supplied. See Fig. 35.

**NOTE:** Be sure that correct nozzle is installed in each distributor before installing expansion valve. Before installing field-supplied nozzles, remove nozzle retainer rings and factory-installed minimum-sized nozzles from distributors.

Install expansion valve (Fig. 35) as follows:

1. Wrap wet cloths around valve body to prevent excessive heat from reaching diaphragm and internal parts. *Do not allow water to enter system.* Disassemble expansion valve before soldering, if accessible, for easy reassembly. Use 95-5 tin-antimony soft solder.
2. Solder expansion valve outlet directly to distributor unless:
  - a. An adapter bushing or coupling is supplied by the factory (solder adapter to distributor first, then to expansion valve).
  - b. Hot gas bypass is required. (See Hot Gas Bypass section, below.)
3. Solder expansion valve equalizer line to suction line and locate control bulb on suction line as in Fig. 32 or 33.
4. Insulate expansion valve body, diaphragm assembly and control bulb area to prevent charge migration and excessive condensation.
5. Install filter drier ahead of expansion valve to ensure satisfactory valve operation.

**HOT GAS BYPASS** — When low-load operation requires use of hot gas bypass, hot gas must be introduced between expansion valve and distributor. See Table 11.

Install hot gas bypass connector (Fig. 36 and 37) in coil split that is *first on, last off* as follows:

1. Remove distributor nozzle and retainer ring (area A) from distributor and reinstall in inlet (area B) of side connector.
2. Solder side connector outlet to distributor inlet, using silver solder or equivalent with 1300 to 1500 F melt temperature.
3. Silver-solder expansion valve outlet to side connector inlet.
4. If required, install factory-supplied adapter bushing or coupling to connector inlet before soldering to expansion valve outlet.

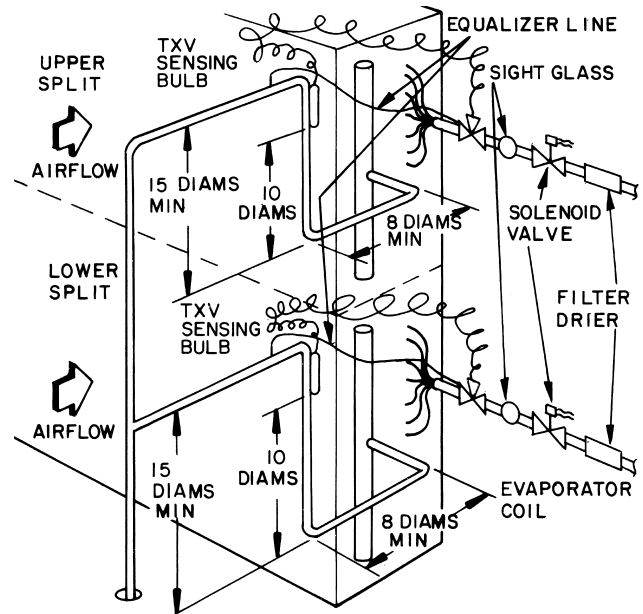

TXV — Thermostatic Expansion Valve

**Fig. 32 — Face Split Coil Suction Line Piping**

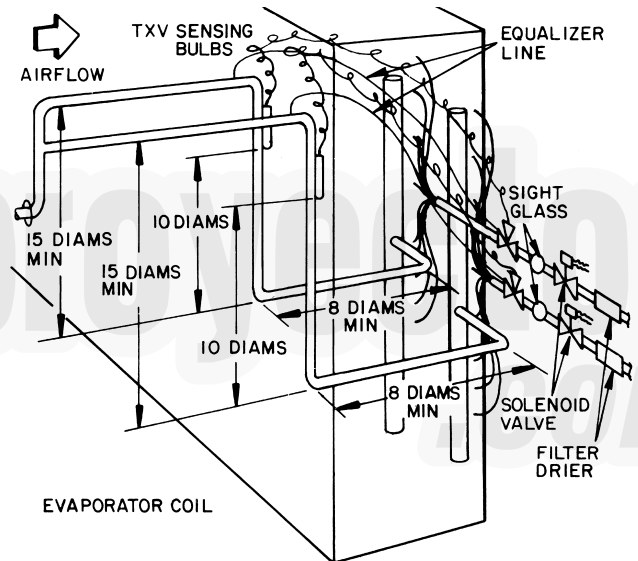

TXV — Thermostatic Expansion Valve

**Fig. 33 — Row Split Coil Suction Line Piping**

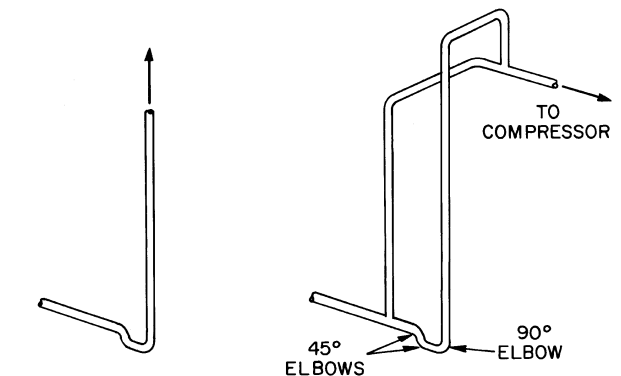

COMPRESSOR ABOVE SINGLE RISER

COMPRESSOR ABOVE DOUBLE RISER

**Fig. 34 — Suction Line Riser Piping**

**Table 9 — Direct Expansion Coil Circuiting Data**

LARGE FACE AREA (39LA, 39LD)														
UNIT SIZE	03			06			08			10			12	
CIRCUITING TYPE	Qtr	Half	Full	Qtr	Half	Full	Qtr	Half	Full	Qtr	Half	Full	Half	Full
CFM AT 550 FPM	1996			3245			4345			5247			6149	
FACE AREA (sq ft)	3.63			5.90			7.90			9.54			11.18	
TUBE FACE	16			20			24			24			24	
TUBE LENGTH (in.)	26.1			34.0			37.9			45.8			53.7	
NUMBER OF CIRCUITS	4	8	16	—	10	20	—	12	24	—	12	24	12	24
NUMBER OF TXVs	2	2	2	—	2	2	—	2	2	—	2	2	2	2
NUMBER OF CIRCUITS/TXV*	2	4	8	—	5	10	—	6	12	—	6	12	6	12
SUCTION CONNECTIONS (in. OD)	7/8	1 1/8	1 3/8	—	1 1/8	1 3/8	—	1 1/8	1 5/8	—	1 1/8	1 5/8	1 1/8	1 5/8
DISTRIBUTOR CONNECTIONS (in. OD)	7/8	7/8	1 1/8	—	7/8	1 1/8	—	7/8	1 5/8	—	7/8	1 5/8	7/8	1 1/8
<b>4-ROW COIL</b>														
Circuit Equivalent Length (ft)	52	26	—	—	32	—	—	34	18	—	40	20	45	23
Distributor Tube Length (in.)														
Face Split	11	11	—	—	11	—	—	13	15	—	13	15	13	15
Row Split	13	15	—	—	16	—	—	18	18	—	18	18	18	18
Distributor Nozzle Size†	2	2	—	—	3	—	—	4	4	—	5	5	6	6
<b>6-ROW COIL</b>														
Circuit Equivalent Length (ft)	—	39	20	—	47	24	—	51	26	—	59	30	67	34
Distributor Tube Length (in.)														
Face Split	—	11	11	—	11	13	—	13	15	—	13	15	13	15
Row Split	—	15	16	—	16	18	—	18	21	—	18	21	18	21
Distributor Nozzle Size†	—	2	3	—	3	3	—	4	4	—	5	5	6	6

LARGE FACE AREA (39LA, 39LD)													
UNIT SIZE	15		18		21		25						
CIRCUITING TYPE	Half	Full	Half	Full	Half	Full	Half		Full		Double		
CFM AT 550 FPM	8200		9740		11,880		13,750						
FACE AREA (sq ft)	14.91		17.71		21.6		25.0						
TUBE FACE	32		38		38		22U-22L						
TUBE LENGTH (in.)	53.7		53.7		65.5		65.5						
NUMBER OF CIRCUITS	16	32	19	38	19	38	22		44		88		
NUMBER OF TXVs	2	4**	2	4**	2	4**	2	2	2	2	4	4	
NUMBER OF CIRCUITS/TXV*	8	8	9-10	9-10	9-10	9-10	5-6	5-6	11	11	11	11	
SUCTION CONNECTIONS (in. OD)	1 1/8	1 3/8	1 3/8	1 3/8	1 3/8	1 1/8	1 1/8	1 1/8	1 5/8	1 5/8	1 5/8	1 5/8	
DISTRIBUTOR CONNECTIONS (in. OD)	1 1/8	1 1/8	1 1/8	1 1/8	1 1/8	1 1/8	7/8	7/8	1 3/8	1 3/8	1 3/8	1 3/8	
<b>4-ROW COIL</b>													
Circuit Equivalent Length (ft)	45	23	45	23	54	26	54	54	26	26	—	—	
Distributor Tube Length (in.)													
Face Split	15	16	16	16	16	16 3/4	12	12	15	15	—	—	
Row Split	26	16	28	16	28	16 3/4	21	21	23	23	—	—	
Distributor Nozzle Size†	8	4	10	5	10	5	8	8	5	5	—	—	
<b>6-ROW COIL</b>													
Circuit Equivalent Length (ft)	67	34	67	34	81	40	—	—	40	40	—	—	
Distributor Tube Length (in.)													
Face Split	15	16	16	18	16	18 1/2	—	—	15	15	—	—	
Row Split	23	16	28	18	28	18 1/2	—	—	22	22	—	—	
Distributor Nozzle Size†	8	4	10	5	10	5	—	—	5	5	—	—	

**LEGEND**

**AHU** — Air-Handling Unit Selection Program  
**TXV** — Thermostatic Expansion Valve (Field-supplied)

\* Where each TXV has the same number of circuits, that number is shown once. When coil has an uneven number of circuits per TXV, both values are shown.

† Factory-supplied distributors have factory-selected nozzle sizes shown. If necessary, replace factory-supplied nozzles with field-supplied and installed nozzles. Consult Electronic Catalog AHU selection program for correct nozzle selection.

\*\* May be field manifolded for either face split or row split.

Table 9 — Direct Expansion Coil Circuiting Data (cont)

SMALL FACE AREA (39LB, 39LC, 39LF)														
UNIT SIZE	03			06			08			10			12	
CIRCUITING TYPE	Qtr	Half	Full	Qtr	Half	Full	Qtr	Half	Full	Qtr	Half	Full	Half	Full
CFM AT 550 FPM	1496			2596			3619			4372			5126	
FACE AREA (sq ft)	2.72			4.72			6.58			7.95			9.32	
TUBE FACE	12			16			20			20			20	
TUBE LENGTH (in.)	26.1			34.0			37.9			45.8			53.7	
NUMBER OF CIRCUITS	4	6	—	4	8	16	—	10	20	—	10	20	10	20
NUMBER OF TXVs	2	2	—	2	2	2	—	2	2	—	2	2	2	2
NUMBER OF CIRCUITS/TXV*	2	3	—	2	4	8	—	5	10	—	5	10	5	10
SUCTION CONNECTIONS (in. OD)	7/8	1 1/8	—	7/8	1 1/8	1 3/8	—	1 1/8	1 3/8	—	1 1/8	1 3/8	1 1/8	1 3/8
DISTRIBUTOR CONNECTIONS (in. OD)	7/8	7/8	—	7/8	7/8	1 1/8	—	7/8	7/8	—	7/8	7/8	7/8	7/8
<b>4-ROW COIL</b>														
Circuit Equivalent Length (ft)	52	26	—	62	32	—	—	34	18	—	40	20	45	23
Distributor Tube Length (in.)														
Face Split	11	11	—	11	11	—	—	11	18	—	11	18	11	18
Row Split	11	11	—	11	15	—	—	16	18	—	16	18	16	18
Distributor Nozzle Size†	1 1/2	1 1/2	—	2 1/2	2 1/2	—	—	4	4	—	5	5	5	5
<b>6-ROW COIL</b>														
Circuit Equivalent Length (ft)	58	39	—	—	47	24	—	51	26	—	59	30	67	34
Distributor Tube Length (in.)														
Face Split	11 1/2	11 1/2	—	—	11 1/2	11 1/2	—	11 1/2	13	—	11 1/2	13	11 1/2	13
Row Split	11 1/2	13	—	—	15	16	—	16	18 1/2	—	16	18 1/2	16	18 1/2
Distributor Nozzle Size†	1 1/2	1 1/2	—	—	2 1/2	3	—	4	4	—	5	5	5	5
<b>8-ROW COIL**</b>														
Circuit Equivalent Length (ft)	—	52	—	—	63	32	—	68	34	—	78	39	89	45
Distributor Tube Length (in.)														
Face Split	—	11 1/2	—	—	11 1/2	11 1/2	—	11 1/2	13	—	11 1/2	13	11 1/2	13
Row Split	—	13	—	—	15	16	—	16	18 1/2	—	16	18 1/2	16	18 1/2
Distributor Nozzle Size†	—	1 1/2	—	—	2 1/2	3	—	4	4	—	5	5	5	5

SMALL FACE AREA (39LB, 39LC, 39LF)										
UNIT SIZE	15		18		21		25		Double	
CIRCUITING TYPE	Half	Full	Half	Full	Half	Full	Half	Full	Half	Full
CFM AT 550 FPM	6666		7689		9405		11,275			
FACE AREA (sq ft)	12.12		13.98		17.1		20.5			
TUBE FACE	26		30		30		36			
TUBE LENGTH (in.)	53.7		53.7		65.5		65.5			
NUMBER OF CIRCUITS	16	26	15	30	15	30	18	36	72	
NUMBER OF TXVs	2	4††	2	4††	2	4††	2	4††	4††	
NUMBER OF CIRCUITS/TXV*	6-7	6-7	7-8	7-8	7-8	7-8	9	9	18	
SUCTION CONNECTIONS (in. OD)	1 3/8	1 3/8	1 3/8	1 3/8	1 3/8	1 3/8	1 3/8	1 3/8	1 5/8	
DISTRIBUTOR CONNECTIONS (in. OD)	7/8	7/8	7/8-1 1/8	7/8-1 1/8	7/8-1 1/8	7/8-1 1/8	1 1/8	1 1/8	1 3/8	
<b>4-ROW COIL</b>										
Circuit Equivalent Length (ft)	45	23	45	23	54	26	54	26	—	
Distributor Tube Length (in.)										
Face Split	13	16	13	16	13/15	16	16	15	—	
Row Split	21	16	23	16	23 1/2	16	26	15	—	
Distributor Nozzle Size†	6	3	8	4	8	4	8	4	—	
<b>6-ROW COIL</b>										
Circuit Equivalent Length (ft)	67	34	67	34	81	40	—	40	—	
Distributor Tube Length (in.)										
Face Split	13	16	13	16	13/15	16	—	16 3/4	—	
Row Split	21	16	23 1/2	16	23 1/2	16	—	16 3/4	—	
Distributor Nozzle Size†	6	3	8	4	8	4	—	4	—	
<b>8-ROW COIL</b>										
Circuit Equivalent Length (ft)	89	45	89	45	—	54	—	54	26	
Distributor Tube Length (in.)										
Face Split	13	16	15	16	—	16	—	16 3/4	16	
Row Split	21	16	23 1/2	16	—	16	—	16 3/4	16	
Distributor Nozzle Size†	6	3	8	4	—	4	—	4	8	

LEGEND

- AHU — Air-Handling Unit Selection Program
- TXV — Thermostatic Expansion Valve (Field-supplied)

\*Where each TXV has the same number of circuits, that number is shown once. When coil has an uneven number of circuits per TXV, both values are shown.

†Factory-supplied distributors have factory-selected nozzle sizes shown. If necessary, replace factory-supplied nozzles with field-supplied and installed nozzles. Consult Electronic Catalog AHU selection program for correct nozzle selection.

\*\*Not available on 39LB units.

††May be field manifolded for either face split or row split.

**Table 10 — Distributor Part Numbers**

PART NO.		NO. OF TUBES	CONNECTION OD (in.)	SPORLAN NOZZLE	
Sporlan	Carrier			Type	Size
1112-2-1/4	EA07NC261	2	0.88	G	3/4 to 12
1112-3-1/4	EA07FC027	3			
1112-4-1/4	EA07NC262	4			
1112-5-1/4	EA07NC263	5			
1112-6-1/4	EA07NC264	6			
1113-7-1/4	EA07HC207	7			
1113-8-1/4	EA07HC208	8	1.12	E	3 to 30
1115-8-1/4	EA07KC240	8			
1115-9-1/4	EA07KC241	9			
1115-10-1/4	EA07KC242	10			
1116-11-1/4	EA07HC011	11			
1117-11-1/4	EA07LC510	11	1.38	C	3 to 50
1117-12-1/4	EA07HC012	12			
1117-13-1/4	EA07HC013	13			
1126-14-1/4	EA07TC290	14			
1126-15-1/4	EA07HC015	15			
1126-16-1/4	EA07TC207	16			
1126-17-1/4	EA07HC017	17			

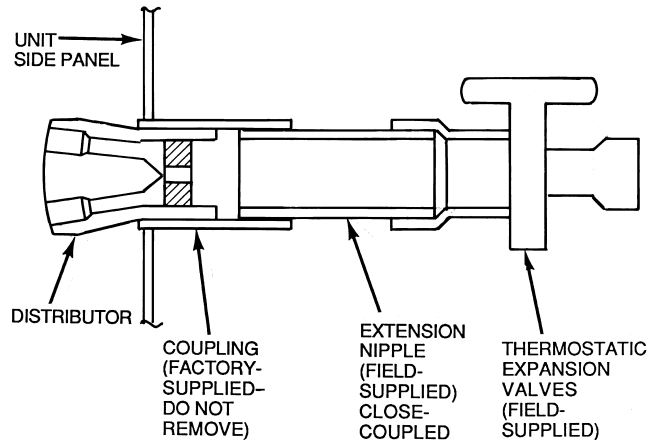

**Fig. 35 — Expansion Valve Piping**

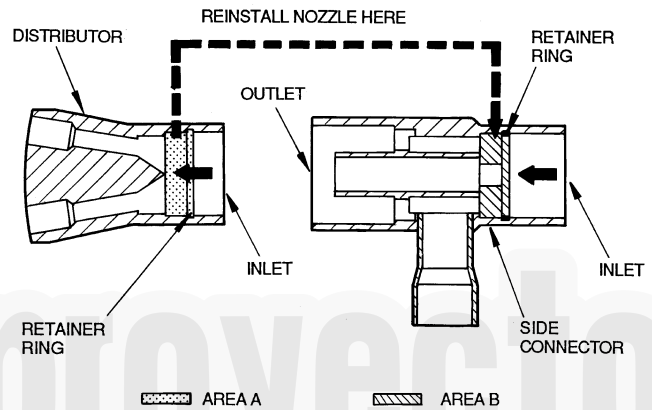
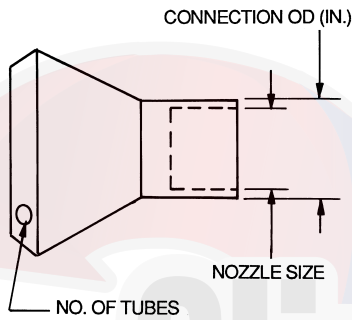

**Fig. 36 — Distributor and Hot Gas Bypass Auxiliary Side Connector**

**Table 11 — Side Connector (Hot Gas Bypass) Data**

SPORLAN TYPE	CARRIER PART NO.	CONNECTION SIZES (in.)			USED WITH DISTRIBUTOR TYPE	NOZZLE SIZE
		Inlet — ODM Solder	Outlet — ODF Solder	Auxiliary — ODF Solder		
ASC-5-4	—	5/8	5/8	1/2	1620, 1622	J
ASC-7-4	EA19BA504	7/8	7/8	1/2	1112, 1113	G
ASC-9-5	EA19BA705	1 1/8	1 1/8	5/8	1115, 1116	E
ASC-11-7	EA19BA905	1 3/8	1 3/8	7/8	1117, 1126	C
ASC-13-9	—	1 5/8	1 5/8	1 1/8	1125, 1127, 1143	A

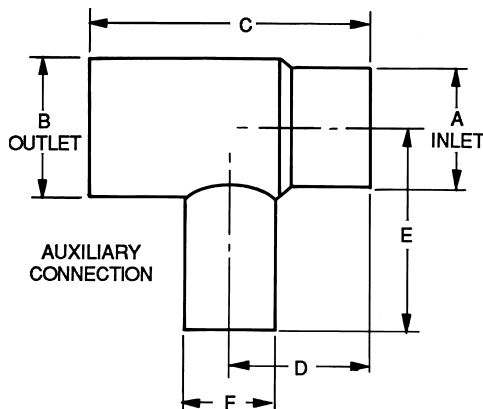

**DIMENSIONS (in.)**

SPORLAN TYPE	A	B	C	D	E	F
ASC-5-4	5/8 ODM	5/8 ODF	1.88	0.95	1.25	1/2 ODM
ASC-7-4	7/8 ODM	7/8 ODF	2.25	1.06	1.38	1/2 ODM
ASC-9-5	1 1/8 ODM	1 1/8 ODF	2.81	1.47	1.62	1 5/8 ODM
ASC-11-7	1 3/8 ODM	1 3/8 ODF	3.53	1.89	2.19	1 7/8 ODM
ASC-13-9	1 5/8 ODM	1 5/8 ODF	3.72	1.83	2.75	1 1/8 ODM

**LEGEND**

- ODF — Outside Diameter, Female
- ODM — Outside Diameter, Male

**Fig. 37 — Side Connector (Hot Gas Bypass) Dimensions**

**UNLOADING CONSIDERATIONS** — Direct expansion coils can have two intertwined refrigerant circuits. In addition, quarter, half, full and double circuiting configurations are offered to allow optimum system performance and oil return at full and part-load operation.

Circuiting selection should result in a circuit loading of 0.8 to 2.0 tons per circuit at design load. Circuit loading must be evaluated at minimum load to ensure that it does not drop below 0.6 tons per circuit. Solenoid valves may be used, if necessary, to shut off the refrigerant supply to individual expansion valves to maintain adequate coil circuit loading.

Compressor minimum unloading and TXV quantity is necessary to determine minimum tonnage per circuit.

Minimum Unloading Equation:

$$\frac{(Tons/Circuit) \times (Minimum Unloading)}{\# \text{ of TXVs Active} \times (Total \# \text{ of TXVs})}$$

Example:

Condensing Unit: 38ARS012

Minimum Unloading: 33%

Coil: 6 row, 11 FPI, Half Circuit

Coil Tons/Circuit: 1.68

Total TXVs: 2

In the first example we will determine the tons/circuit when both TXVs are active and the compressor is unloaded to its minimum of 33%.

$$\begin{aligned} & \frac{(1.68 \text{ Tons/Circuit}) \times (33\% \text{ Minimum Unloading})}{2 \text{ TXVs Active} \times (2 \text{ TXVs})} \\ &= \frac{(1.68) \times (.33) \times (2)}{2} \end{aligned}$$

= .55 tons/circuit at minimum unloading UNACCEPTABLE

If we install a liquid line solenoid valve before one of the TXVs and close it so that only one TXV is active when the compressor is unloaded to its minimum of 33%, we see the following:

$$\begin{aligned} & \frac{(1.68 \text{ Tons/Circuit}) \times (33\% \text{ Minimum Unloading})}{1 \text{ TXV Active} \times (2 \text{ TXVs})} \\ &= \frac{(1.68) \times (.33) \times (2)}{1} \end{aligned}$$

= 1.10 tons/circuit at minimum unloading ACCEPTABLE

### SPECIAL PIPING WITH 4 SPLITS PER COIL

**Manifolding for 2-Face Splits** — Refer to Fig. 38 and externally manifold as follows:

1. Connect the 4 expansion valves to the 4 distributors on each coil and connect the 4 suction lines to the 15-diameter-long risers as outlined in previous piping instructions.
2. Install common liquid line for upper face split to first (upper) and second expansion valves. Also, install a common suction line from suction lines attached to first (upper) and second suction header connections.
3. Repeat Step 2 for lower face split using third and fourth distributor and suction connections.

**Manifolding for 2-Row Splits** — Refer to Fig. 39 and externally manifold as outlined for the 2-face splits with the following exceptions:

1. Manifold in pairs, the first and third coil connections for one split.
2. Manifold the second and fourth pairs of coil connections for the other split.

NOTE: Split section using first and third pairs of coil connections should be *first on, last off* for coils with right hand (facing direction of airflow) connections and the reverse for left hand connections.

**Hot Gas Bypass Connection with 4 Splits per Coil** — For either face or row splits connect a hot gas bypass auxiliary side connector to each distributor of coil split that is *first on, last off*. Refer to installation instructions for Hot Gas Bypass.

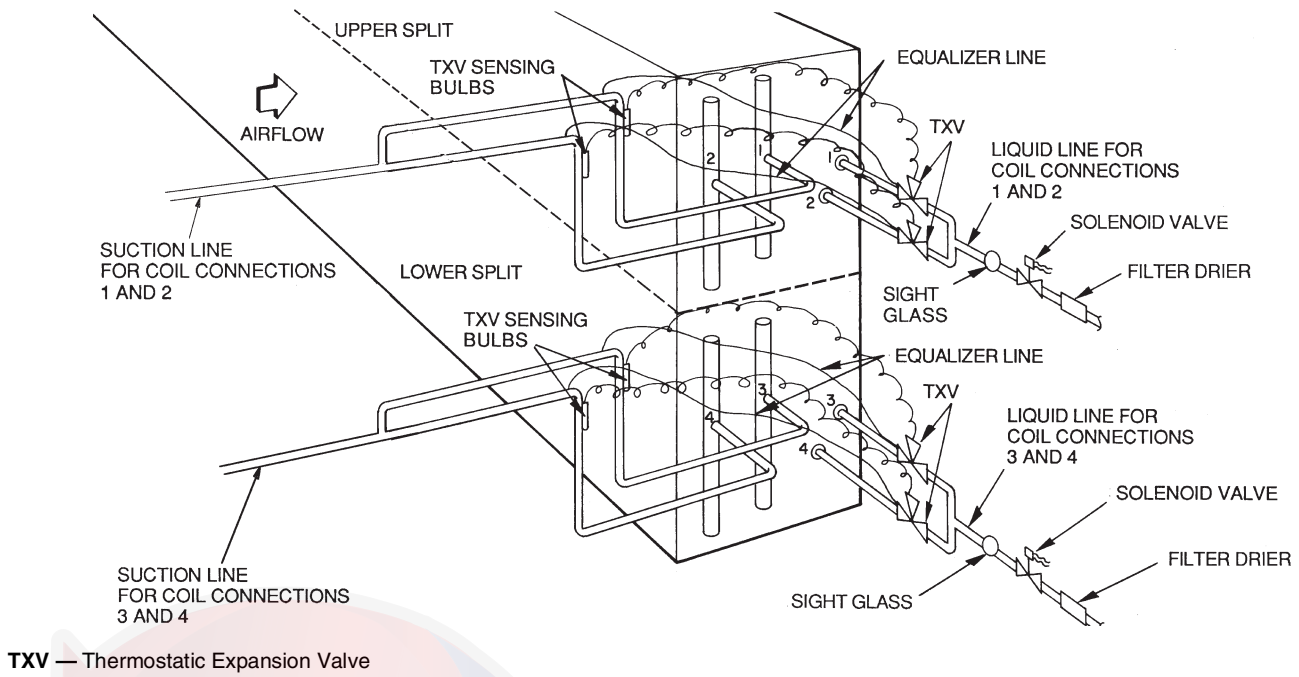

**Fig. 38 — Face Split Coil Manifolding (Typical)**

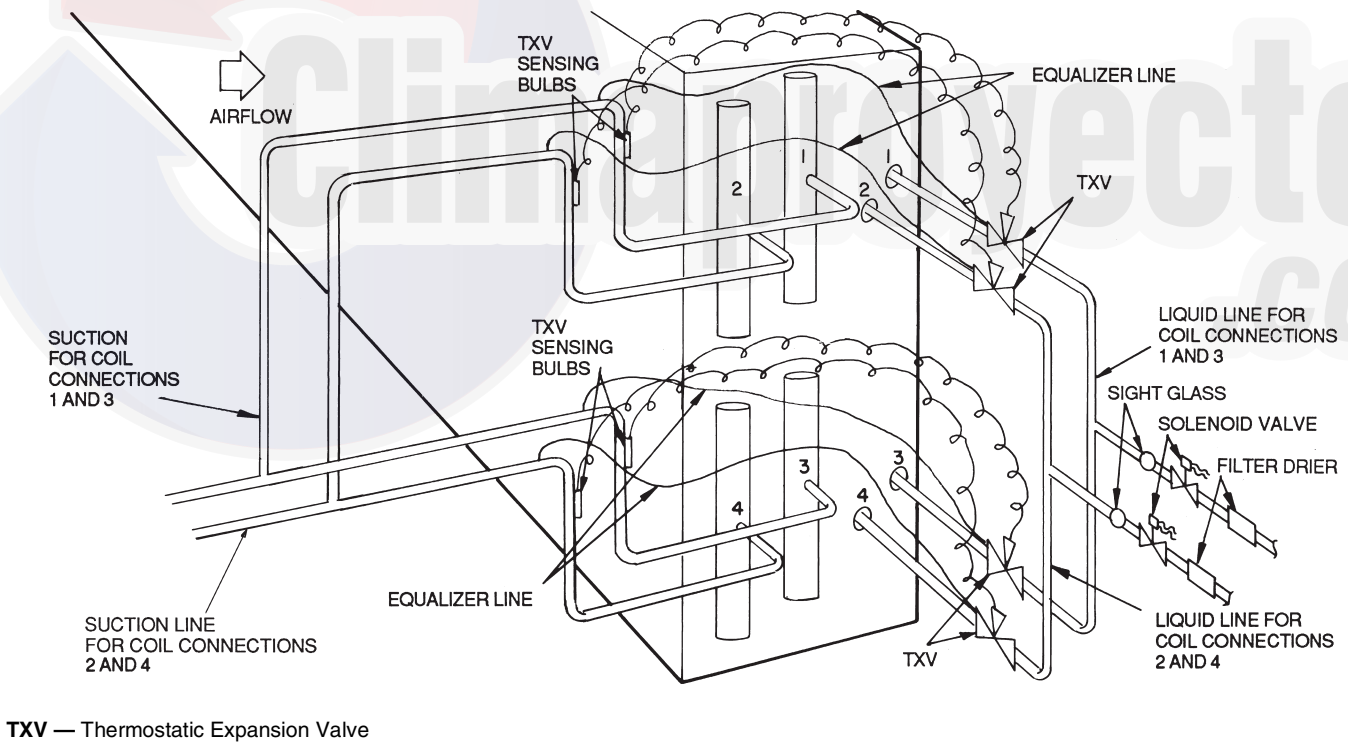

**Fig. 39 — Row Split Coil Manifolding (Typical)**

**Electric Heaters** — Electric heaters may be factory installed or drop shipped to the jobsite and field installed. The heater can only be installed in the preheat-electric section.

To install electric heater, refer to Fig. 40 and proceed as follows:

1. Locate preheat-electric section already mounted on unit and remove protective shipping cover.
2. Locate crate containing electric heater and verify heater matches the unit. Unit hand and heater hands must agree.
3. Remove both knockout slugs (power and signal). Install conduit connectors in top of coil connection box.
4. Remove top panel of the preheat-electric section and drill or punch 2 holes are specified in Fig. 40.
5. Insert the electric heater into unit. It must slide between 2 angles located on the bottom of the section.
6. Secure heater to the preheat-electric section using 4 screws.
7. Locate top panel of section. Run conduit through top panel and tighten conduit connectors. Lower top panel and replace panel on unit.
8. Complete wiring per wiring diagram and job requirements. Follow all applicable local codes.

**CONNECT POWER AND CONTROL WIRES** — Heater wiring schematic is located on control box panel. (Figure 41 shows typical wiring details.) Electrical data for each standard heater arrangement is shown in Table 12. Verify that minimum airflow requirement (minimum coil face velocity, fpm) will be met, especially on applications where variable air volume is supplied.

Use copper power supply wires rated for 75 C minimum. On 250-v or greater applications, use 600-v rated wiring. Size wires to carry 125% of current load on each set of terminals (Table 12). Use the following formulas as required:

Single-phase line current

$$= \frac{1 \text{ (kW per set of terminals) (1000)}}{\text{voltage}}$$

Three-phase line current

$$= \frac{(\text{kW per set of terminals}) (1000)}{(\text{voltage}) (1.73)}$$

$$(\text{kW per set of terminals}) (1000) = (\text{voltage}) (1.73)$$

Note that if the heater is rated at 50 kW (or more) and is controlled by a cycling device such as a multi-stage thermostat, or a step controller, conductors may be sized at 100% of load amperes (as in Tables 12 and 13) per National Electrical Code (NEC) Section 424-22. Heater construction and application information (Tables 12 and 13) are based upon Underwriters' Laboratories (UL) Space Heating Standard No. 1096 and the requirements of the NEC. Installer is responsible for observing local code requirements.

Install a disconnect switch or main circuit breaker in accordance with NEC and other applicable codes. Locate so that it is easily accessible and within sight of heater control box (per NEC Article 424-19 and 424-65).

Weatherproof junction boxes have no knockouts for wire entrance. Drill or punch holes for conduit as required and make all junctions watertight.

Where field-supplied thermostats are used, isolate circuits to prevent possible interconnection of control circuit wiring.

Where field-supplied step controller is used, connect steps to terminals as marked on wiring schematic. When connecting multi-stage heaters, wire stage no. 1 so that it is first stage on, last stage off. Connect thermostats as required.

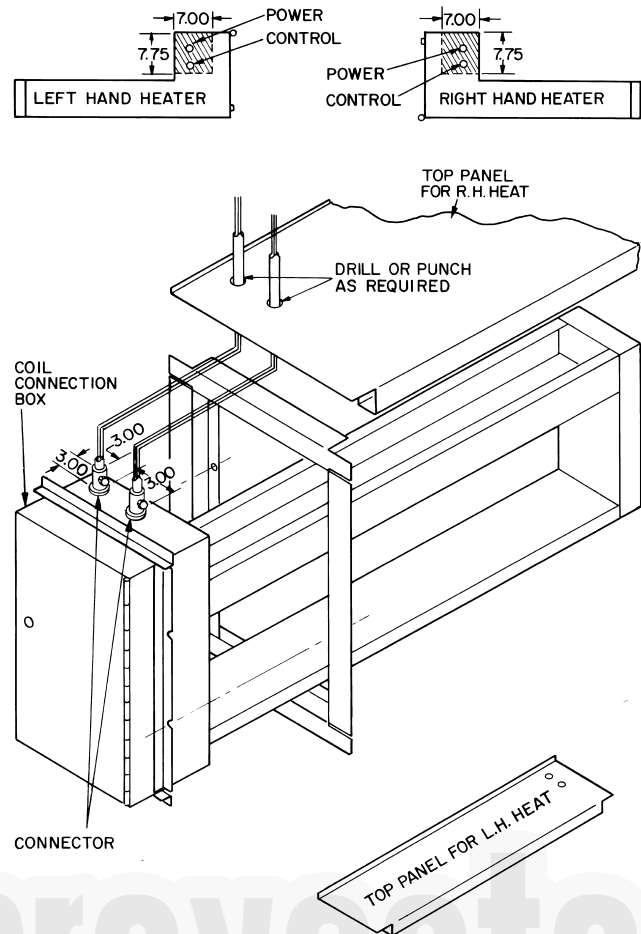

**Fig. 40 — Electric Heater Installation**

Provide sufficient clearance for convection cooling of heaters with solid-state controllers. Provide at least 5-in. of free air space above and below cooling fins extending from heater terminal box. Be sure to connect interlock terminals F1 and F2 to auxiliary contacts on fan starter.

Each heater has 2 different types of factory-installed thermal cutouts for overtemperature protection; an automatic reset thermal cutout for primary protection and a manual reset thermal cutout to protect against failure of the primary system. Also provided is an airflow pressure differential switch to prevent the heater from operating when the fan is not in operation or airflow is restricted or insufficient. The primary automatic reset cutout is a bi-metal disk-type cutout. It is wired into the control circuit which operates the magnetic disconnecting contactors (the same contactors which also switch on and off the various steps of the coil). The secondary manual reset cutout is a bi-metal disk-type cut-out. This secondary thermal cutout is load carrying and is installed in each heater sub-circuit. The primary and secondary overtemperature protection systems are independent of each other. The secondary system is designed to protect against possible failure of the primary system to deenergize the heater.

Subcircuits in the heaters are designed in compliance with paragraph 424-22 of the NEC. The coil is subdivided into circuits that draw no more than 48 amps each and is fused for at least 125% of the circuit rating.

Pitot tube is to be positioned so that the airflow switch is actuated by a minimum negative pressure of 0.07 in. wg.

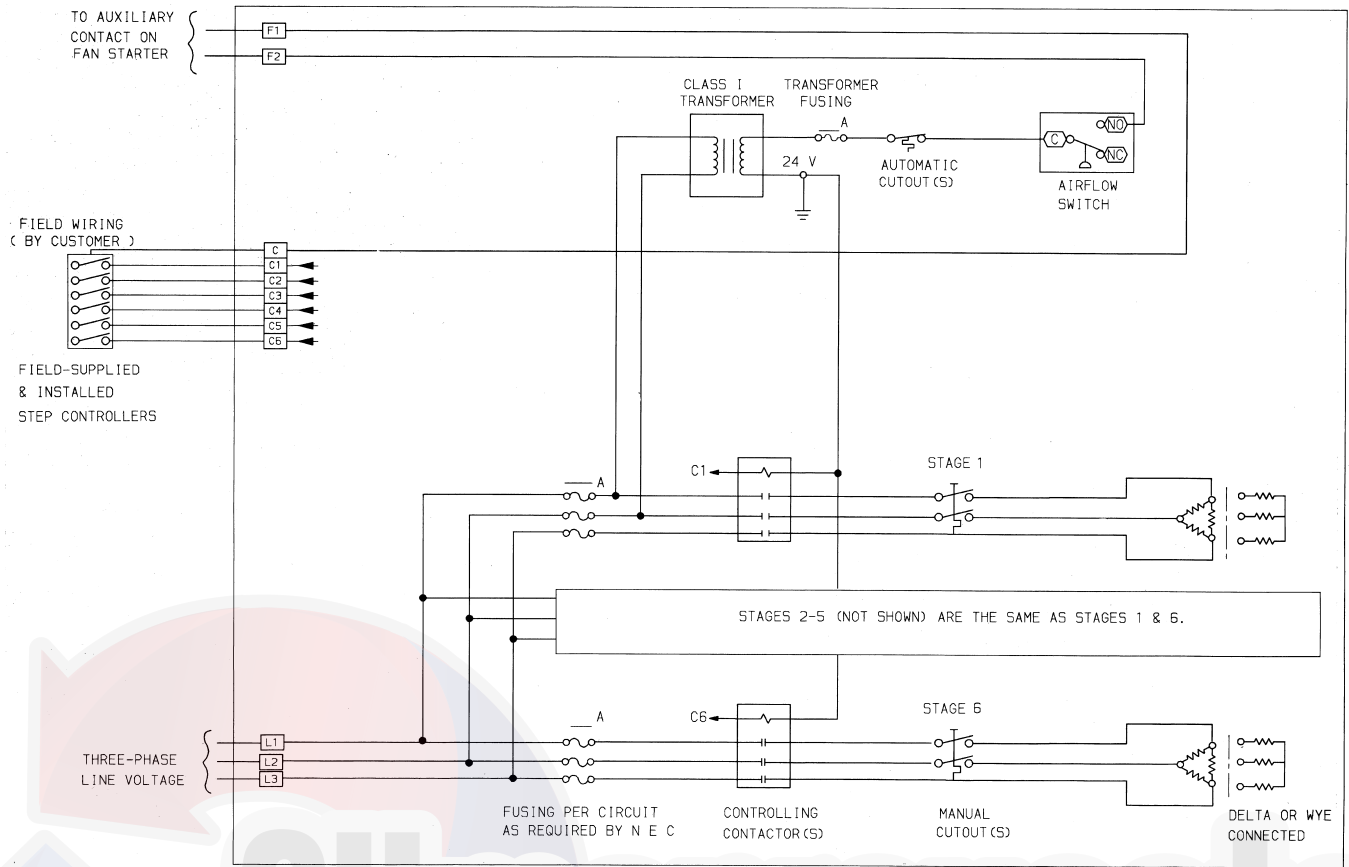

NOTE: All wiring must be copper and must conform to the NEC (National Electrical Code).

**Fig. 41 — Typical Electric Heater Wiring Schematic**





**Table 13 — Field Wiring for Incoming Conductors Sized for 125% of Heater Load**

WIRE SIZE (AWG or kcmil)	LOAD AMPS*	
	Copper	Aluminum
12	16	120
10	24	140
8	40	160
6	52	184
4	68	204
3	80	228
2	92	248
1	104	268
		304

**LEGEND**

**AWG** — American Wire Gage  
**kcmil** — Thousand Circular Mils

\*Values are based on Table 310-16 of the NEC (National Electrical Code) for 75 C insulated copper wire. Not more than 3 conductors in a raceway.

**NOTES:**

1. Be sure to consider length of wiring run and possible voltage drops when sizing wires.
2. Field power wiring — Heaters are furnished with a terminal block sized for incoming copper conductors with 75 C insulation rated to carry at least 125% of the heater load. However, conductors can be sized to carry 100% of the heater load if the heater is rated at 50 kW or more, and the heater is controlled by a cycling device such as a multi-stage thermostat, step controller, or SCR (silicon control rectifier) power controller. Terminal blocks and knockouts are sized to handle either 100% or 125% conductors.

**Discharge Modification** — If field modification of discharge position is required, 39L fans can be converted (by a skilled mechanic) to any standard hand and discharge without any

additional parts. (NOTE: This does not apply to a model change conversion.) All mounting holes are pre-punched.

To convert a 39L fan, note the following:

1. Sizes 03-18 w — See Fig. 42. It is not necessary to remove the bearing support channels from the fan housing.  
 Sizes 21 and 25 — See Fig. 43. The “A” frame support must be removed. To change from upblast to horizontal discharge or from horizontal to upblast discharge, the bearings must be relocated to keep the wheel centered in the housing. To change from upblast front (UBF) to upblast rear (UBR) or from top horizontal front (THF) to top horizontal rear (THR) or vice versa, turn the entire fan housing 180 degrees about its base.
2. The fan shaft may be driven out and reinstalled to place the drive pulley on the opposite end.
3. The fan scroll is pre-punched for horizontal or vertical discharge to match the support angles at the base of the unit.
4. The motor and motor base may be rotated to place the motor at the front or rear of the unit. Proper location is that which results in the longest drive center line distance. The motor conduit box location may need to be reversed.
5. When hand of fan is changed, it may be necessary to turn the discharge panel inside-out to fit correctly with the fan discharge. In this case, remove the existing insulation and install new duct-liner type insulation on the opposite side of the discharge panel.
6. Rebalancing of the unit is recommended.

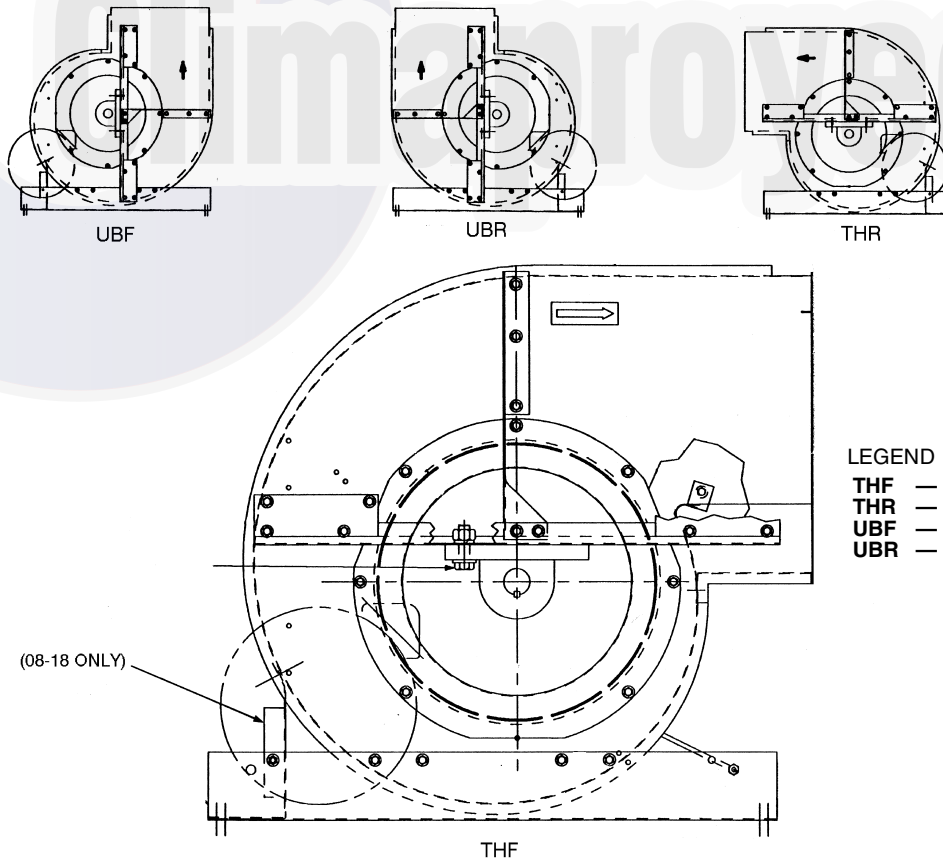

**Fig. 42 — Fan Discharge Positions, Sizes 03-18**

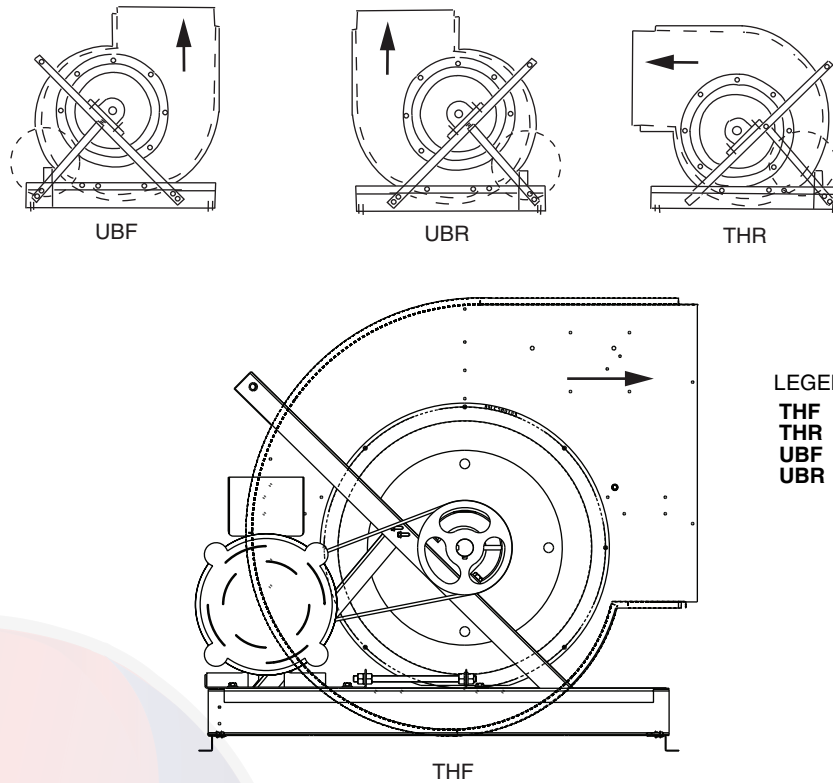

Fig. 43 — Fan Discharge Positions, Sizes 21 and 25

### START-UP

**Check List** — Make a walkway inside unit components to protect insulation. Remove all construction debris from unit interior. *Remove walkway before starting unit.*

**FILTERS** — Install unit filters in all filter sections.

#### FANS

1. Check lubrication of fan, motor bearings, and linkages.
  - a. Note that bearings are shipped completely full of grease for corrosion protection and may run warm temporarily on start-up until excess grease has discharged.
  - b. Hand-operate all linkages, such as damper and guide vanes, to check for freedom of movement.
2. Check tightness of bearing setscrews or locking collars (Fig. 44). Also, check tightness of setscrews on fan wheels and sheaves.
3. Check tightness of fan shaft bearing mounting.
4. Recheck sheave alignment and belt tension. (Refer to Fig. 22 and 23.)
5. Hand turn fan to make certain fan wheel does not rub in housing.

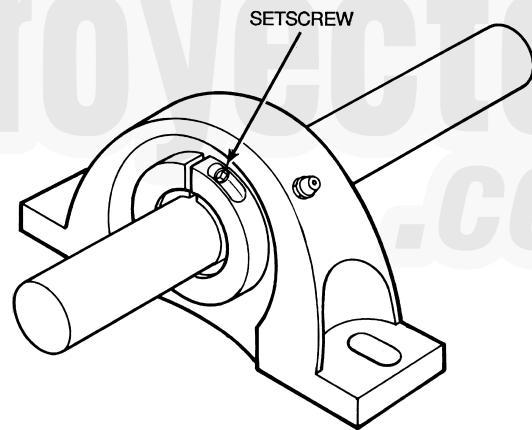

SQUEEZE-TYPE LOCKING COLLAR  
BEARING SETSCREW TORQUE (in.-lb)

39L UNIT SIZE	TORQUE
03,06,08,10,12	70
15,18,21,25	90

BEARING HOLDDOWN BOLT TORGQUE (ft-lb)

BOLT SIZE	TORQUE
3/8-16	30
1/2-13	63
5/8-11	100

Fig. 44 — Fan Shaft Bearing Details

6. Check fan speed with a strobe-type tachometer or use the following formula: Obtain the motor rpm from the fan motor nameplate and read sheave pitch diameters marked on the fan and motor pulleys, or estimate the pitch diameters by using the pulley outside diameters.

Then:

$$\text{Fan Rpm} = \frac{\text{Motor Rpm} \times \text{Motor Sheave Pitch Diameter (in.)}}{\text{Fan Sheave Pitch Diameter (in.)}}$$

Example:

	<u>Actual</u>	<u>Approximate</u>
Nameplate Motor Rpm	= 1760	1760
Mtr Sheave Pitch Diameter	= 8.9 in.	9.0 (OD)
Fan Sheave Pitch Diameter	= 12.4 in.	12.5 (OD)
Fan Rpm	= $\frac{1760 \times 8.9}{12.4}$	$\frac{1760 \times 9}{12.5}$
	= 1263 Rpm	1267 Rpm

Refer to Table 1, Physical Data for maximum allowable fan speeds for standard wheels. *Excessive fan speed may result in condensate carryover from cooling coil or fan motor overload and wheel failure.*

7. Check direction of rotation (see Fig. 45). Arrow on drive side of fan housing indicates correct direction of rotation.

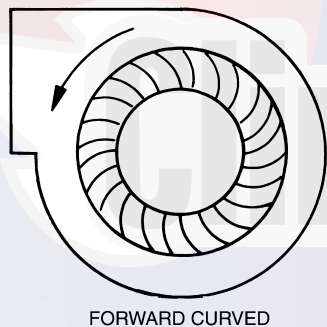

**Fig. 45 — Fan Wheel Rotation**

8. Check vibration. If excessive vibration occurs, check for the following:
  - a. Variable sheave (if air balance of system has been accomplished: replace sheave with fixed sheave for continuous application).
  - b. Drive misalignment.
  - c. Mismatched, worn or loose belts.
  - d. Wheel or sheaves loose on shaft.
  - e. Loose bearings.
  - f. Loose mounting bolts.
  - g. Motor out of balance.
  - h. Sheaves eccentric or out of balance.
  - i. Vibration isolators improperly adjusted.
  - j. Out-of-balance or corroded wheel (rebalance or replace if necessary).
  - k. Accumulation of material on wheel (remove excess material).

## COILS

Chilled Water Coil — Typical coil vents, drains, and lifting points are shown in Fig. 25.

DX Coil — Charge refrigerant. Also refer to condensing unit service and installation instructions. Refrigerant operating charge for unit coil is shown in Table 2.

## SERVICE

### General

1. Place a suitable walkway to protect floor insulation whenever entering the fan section.
2. Review Safety Considerations at beginning of these instructions. Good safety habits are important tools when performing service procedures.
3. To make speed measurements, use a strobe-style tachometer or calculate per Step 6 of Start-Up, Check List on page 35.

### Fan Motor Replacement

1. Shut off motor power.
2. Disconnect and tag power wires at motor terminals.
3. Loosen motor brace-to-mounting-rail attaching bolts. Loosen belt tensioning bolts to adjust the motor position so V-belts can be removed without stretching over grooves.
4. Mark belt as to position. Remove and set aside belts.
5. Remove motor to motor bracket holddown bolts.
6. Remove motor pulley and set aside.
7. Remove motor.
8. Install new motor. Reassemble by reversing Steps 1-6. Be sure to reinstall multiple belts in their original position. Use a complete new set if required. Do not stretch belts over sheaves. Review the sections on motor and sheave installation, sheave alignment and belt tensioning discussed previously (Fig. 21-23).
9. Reconnect motor leads and restore power. Check fan for proper rotation as described in Start-Up, Check List on page 35.

### Coil Cleaning

**DETERGENT** — Spray mild detergent solution on coils with garden-type sprayer. Rinse with fresh water. Check to ensure condensate line is free. Excess water from cleaning may flood unit if condensate line is plugged.

**STEAM** — Remove coil to facilitate cleaning and prevent damage to unit insulation. See Coil Removal section on page 37.

**Winter Shutdown (Chilled Water Coil Only)** — It is recommended that auxiliary drain piping be added to coil piping if yearly winterizing of coils is anticipated. This auxiliary piping should be located at the highest and lowest point on the respective header connection for each coil.

### ANTIFREEZE METHODS OF COIL PROTECTION

1. Close coil water supply and return valves.
2. Drain coil as follows:
 

*Method I* — ‘Break’ flange of coupling at each header location. Separate flange or coupling connection to facilitate coil draining.

*Method II* — Open both valves to auxiliary drain piping.
3. After coil is drained, *Method I*, connect line with a service valve and union from upper nozzle to an antifreeze reservoir. Connect a self-priming reversible pump between the low header connection and the reservoir. *Method II*, make connection to auxiliary drain valves.
4. Fill reservoir with any inhibited antifreeze acceptable to code and underwriter authority.
5. Open service valve and circulate solution for 15 minutes; then check its strength.

6. If solution is too weak, add more antifreeze until desired strength is reached, then circulate solution through coil for 15 minutes or until concentration is satisfactory.
7. Remove upper line from reservoir to reversible pump. Drain coil to reservoir and then close service valve.
8. Break union and remove reservoir and its lines.
9. Leave coil flanges or coupling open and auxiliary drain valves open until spring.

**AIR DRYING METHOD OF COIL PROTECTION** (Unit and coil must be level for this method.)

1. Close coil water supply and return main valves.
2. Drain coil as described in procedures for Antifreeze Methods of Coil Protection.
3. Connect air supply or air blower to inlet header connection and close its drain connection.
4. Circulate air and check for air dryness by holding mirror in front of open vent in outlet header drain connection. Mirror will fog if water is still present.
5. Allow coil to stand for a few minutes; repeat step 4 until coil is dry.

**Field-Installed Coils (39LA,LD Only)** — When a 39LA or 39LD unit is ordered without the coil, the following loose parts are shipped (see Fig. 46):

- bottom coil baffle
- side hairpin baffle
- side header baffle
- top coil baffle

These parts should be field-installed onto the coil before placing the coil into the unit. Once the baffles are installed, install the

coil with the downstream bottom of the coil attached to the upright mounting flange as shown in Fig. 45. Adjust the coil and then attach the top coil baffle to the top flange provided.

### Coil Removal

**HORIZONTAL UNIT SLANT COIL REMOVAL (39LA Units)**

NOTE: Item numbers are in Fig. 47.

1. Refer to Fig. 10 for service area clearance.
2. Disconnect piping (Item 5).
3. On top panel (Item 3), remove screws located directly above side panels (Items 2 and 6). Top panels may be removed from unit to provide more workspace, but it is not required.
4. Remove right side panels (Item 6).
5. If accessory is present, remove accessory side panel (Item 1) on left side of unit. Detach filter track support bracket if upstream accessory is a filter.
6. Remove screws from inside baffle (Item 13). Leave baffle attached to left side panel (Item 2).
7. Remove left side panel (Item 2).
8. Remove condensate baffle (Item 8).
9. Remove coil holddown screws (Items 9 and 11).
10. Remove baffle screws (Item 4) from downstream side of coil.
11. Tilt coil (Item 10) away from coil support panels (Items 7 and 12) and slowly slide coil out of unit.
12. Replace coil by reversing preceding Steps 1-11.

Climaproyectos  
.com

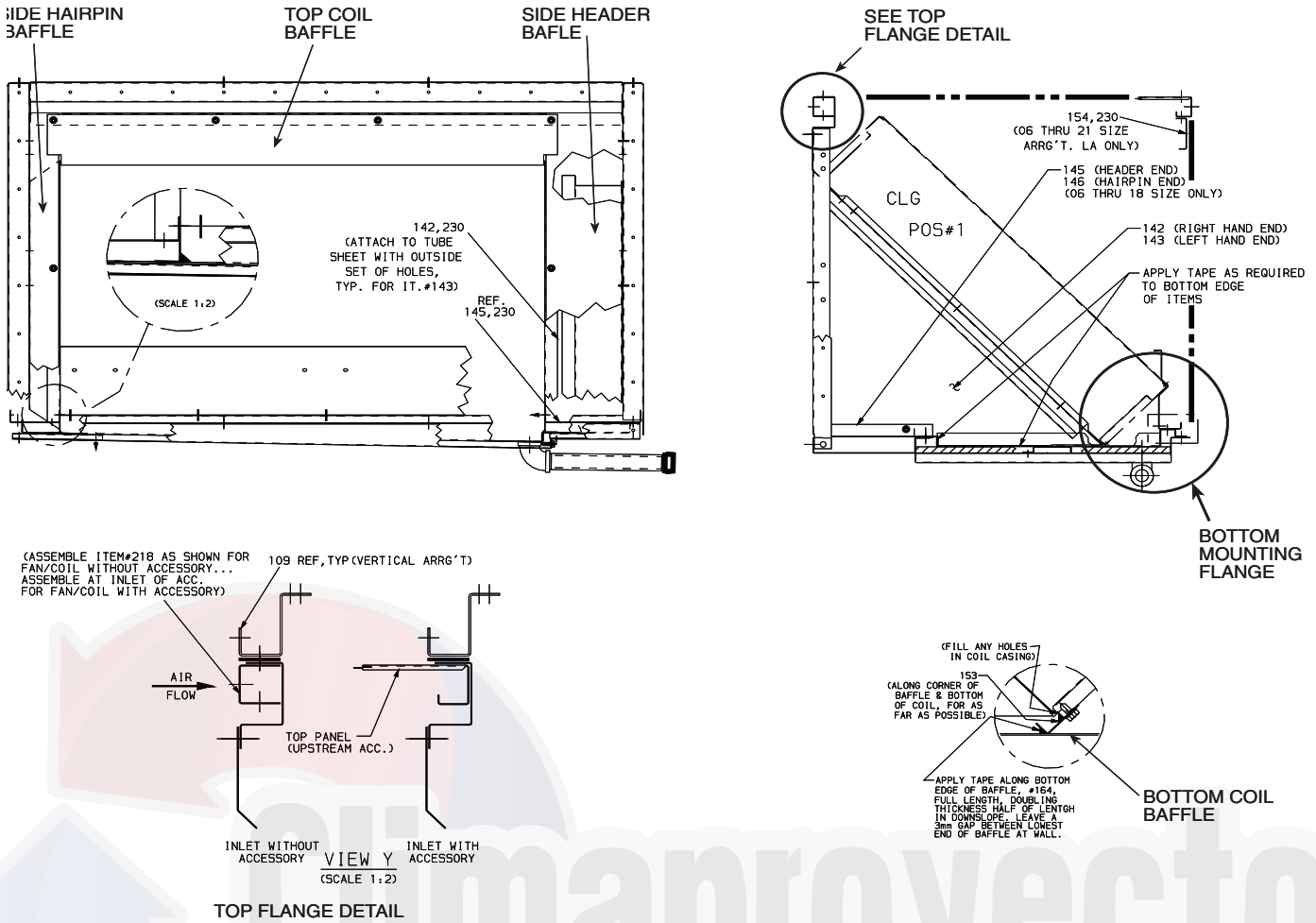
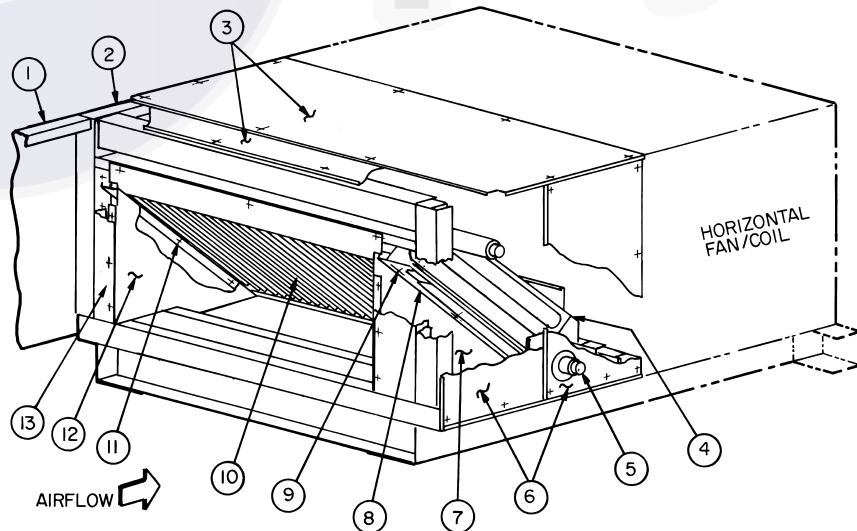

Fig. 46 — Field-Installed Coils (39LA and LD only)



LEGEND

- |                          |                         |
|--------------------------|-------------------------|
| 1 — Accessory Side Panel | 8 — Condensate Baffle   |
| 2 — Left Side Panel      | 9 — Holddown Screws     |
| 3 — Top Panels           | 10 — Coil               |
| 4 — Baffle Screws        | 11 — Holddown Screws    |
| 5 — Piping               | 12 — Left Support Panel |
| 6 — Right Side Panels    | 13 — Inside Baffle      |
| 7 — Right Support Panel  |                         |

Fig. 47 — Horizontal Unit Slant Coil Removal (39LA Units — Sizes 03-21)

**VERTICAL UNIT SLANT COIL REMOVAL (39LD Units)**

NOTE: Item numbers are in Fig. 48.

1. Refer to Fig. 10 for service area clearance.
2. Disconnect piping (Item 6).
3. Through fan access door (Item 2), remove screws (Item 3), while holding angle (Item 4) to top of coil side panels (Item 7). On opposite end of unit, gain access to similar screws by removing side panels (Item 1).
4. Remove right side panels (Item 7).

NOTE: Support of fan section may be required after removal of side panels (Items 7 and 16).

5. If accessory is present, remove accessory side panel (Item 15) on left side of unit. Detach filter track support bracket if upstream accessory is a filter.

6. Remove screws from inside baffle (item 14). Leave baffle attached to left side panel (Item 16).
7. Remove left side panel (Item 16).  
NOTE: Support of fan section may be required after removal of side panels (Items 7 and 16).
8. Remove condensate baffle (Item 9).
9. Remove coil holddown screws (Items 10 and 12).
10. Remove baffle screws (Item 5) from downstream side of coil.
11. Tilt coil (Item 11) away from coil support panels (Items 8 and 13).
12. Replace coil by reversing preceding Steps 1 - 11.

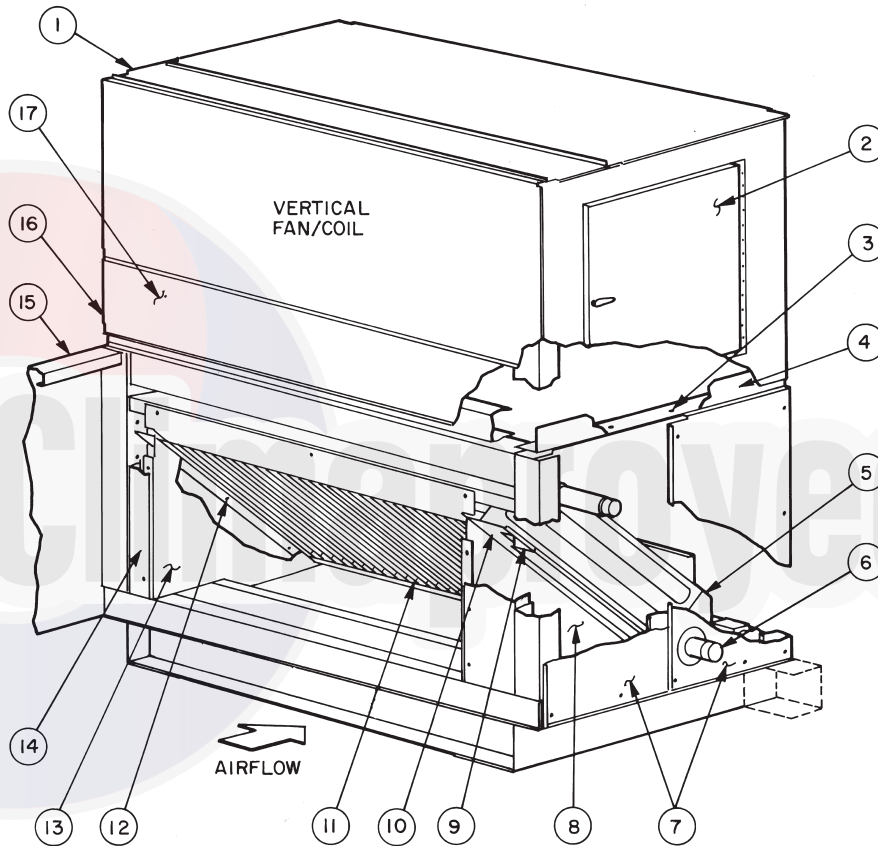

**LEGEND**

- |                         |                           |
|-------------------------|---------------------------|
| 1 — Fan Side Panel      | 10 — Holddown Screws      |
| 2 — Fan Access Door     | 11 — Coil                 |
| 3 — Screws              | 12 — Holddown Screws      |
| 4 — Angle               | 13 — Left Support Panel   |
| 5 — Baffle Screws       | 14 — Inside Baffle        |
| 6 — Piping              | 15 — Accessory Side Panel |
| 7 — Right Side Panels   | 16 — Left Side Panels     |
| 8 — Right Support Panel | 17 — Rear Panel           |
| 9 — Condensate Baffle   |                           |

**Fig. 48 — Vertical Unit Slant Coil Removal (39LD Units — Sizes 03-21)**

**HORIZONTAL OR VERTICAL UNIT — DUAL COIL REMOVAL (39LA,39LD units — size 25) — (NOTE: Item numbers are in Fig. 49 unless otherwise indicated.)**

1. Refer to Fig. 10 for service area requirements.
2. Disconnect piping (Item 5).
3. Horizontal Unit, 39LA — On top panel (Item 3) remove screws located directly above side panels (Items 2 and 6). Top panels may be removed from unit to provide more workspace, but it is not required.

Vertical Unit, 39LD — Through fan access door (Item 2, Fig. 41), remove screws (Item 3, Fig. 48) holding angle (Item 4, Fig. 48) to top of coil panels (Item 7, Fig. 48).

Remove rear panel (Item 17, Fig. 48) and remove baffle angle screws (Item 4) holding top baffle to coil.

4. Remove side panel(s) (Item 6).  
NOTE: Vertical units may require support of fan section after removal of side panels.
5. If accessory is present, remove accessory side panel (Item 1) on left side of unit. Detach filter track support bracket if upstream accessory is a filter.
6. Remove screws from horizontal baffle (Item 8). Leave baffle attached to upper condensate pan (Item 9).
7. Remove screws from inside baffles (Item 7). Leave baffles attached to left side panel (Item 2).
8. Slide coils and header and baffles from unit.
9. Replace coils by reversing proceeding Steps 1-8.

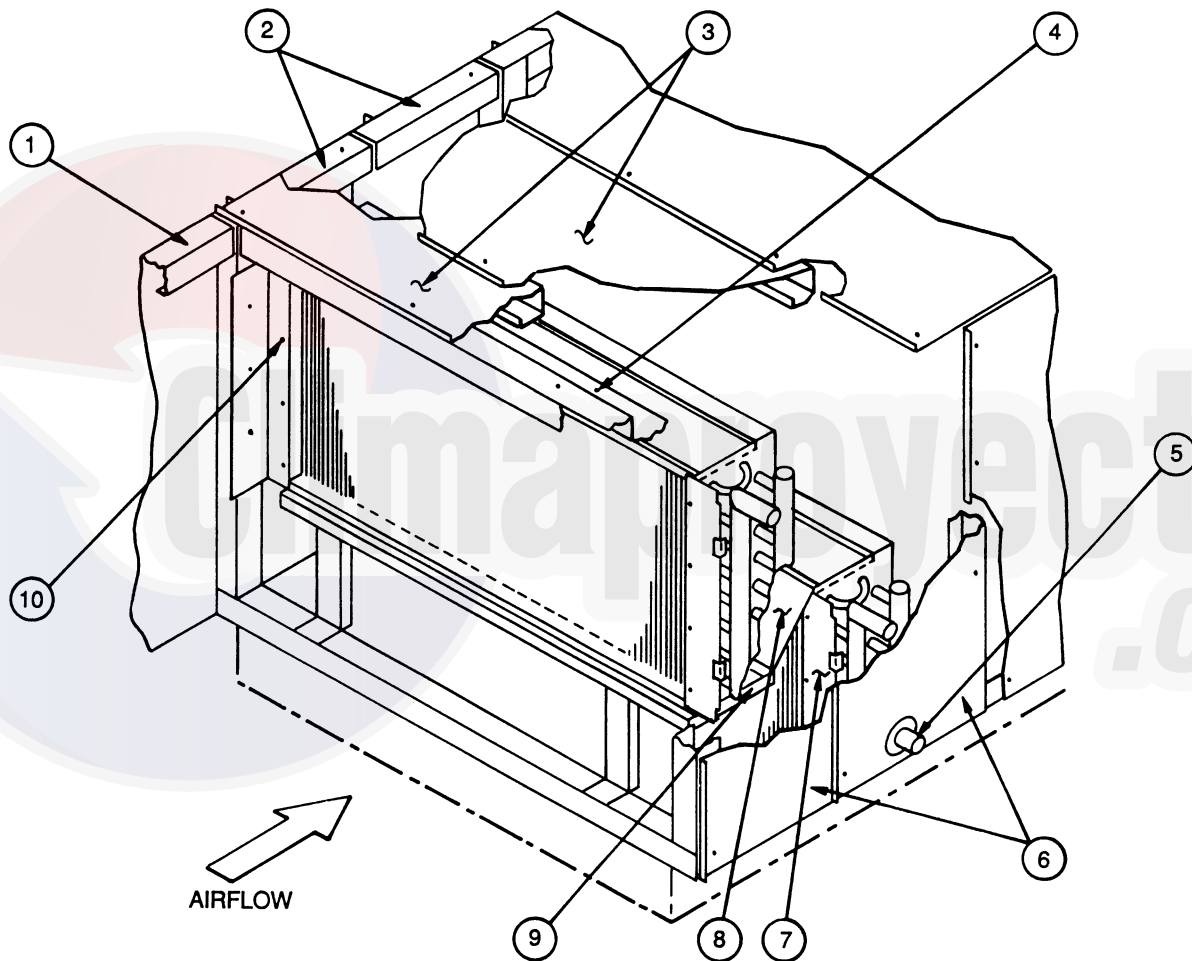

**LEGEND**

- |                          |                          |
|--------------------------|--------------------------|
| 1 — Accessory Side Panel | 6 — Right Side Panels    |
| 2 — Left Side Panel      | 7 — Inside Baffle        |
| 3 — Top Panels           | 8 — Horizontal Baffle    |
| 4 — Baffle Angle Screws  | 9 — Upper Condensate Pan |
| 5 — Piping               | 10 — Baffle Screw        |

**Fig. 49 — Horizontal or Vertical Unit — Dual Coil Removal (39LA,LD Units, Sizes 25)**



**HORIZONTAL OR VERTICAL UNIT — VERTICAL COIL REMOVAL (39LB,LC,LF,LH Units) —** Item numbers are in Fig. 50 unless otherwise indicated.

1. Refer to Fig. 10 for service area requirements.
2. Disconnect piping (Item 6).
3. Horizontal Unit, 39LB and 39LC — On top panel (Item 4) remove screws located directly above side panels (Items 2 and 7). Top panels may be removed from unit to provide more workspace, but it is not required.

Vertical Unit, 39LF and 39LH — Through fan access door (Item 2, Fig. 48), remove screws (Item 3, Fig. 48) holding angle (Item 4, Fig. 46) to top of coil panels (Item 7, Fig. 48).

Remove rear panel (Item 17, Fig. 48) and remove baffle angle screws (Item 5) holding top baffle to coil.

4. Remove side panel(s) (Item 7).  
NOTE: Vertical units may require support of fan section after removal of side panels.
5. If accessory is present, remove accessory side panel (Item 1) on left side of unit. Detach filter track support bracket if upstream accessory is a filter.
6. Remove screws (Item 8) from inside baffle (Item 3). Leave baffle attached to left side panel (Item 2).
7. Slide coil and header end baffle from unit.
8. Replace coil by reversing preceding Steps 1-7.

**Changing Coil Hand**

NOTE: Electric heat coil hand cannot be changed.

NOTE: The coil cover panel is not part of the coil. Remove cover panel from end of unit. New holes must be cut in coil cover panel. Original holes must be plugged and insulated. New side panels may be necessary when changing coil hand.

NU-FIN COILS — The NuFin coil is airflow direction sensitive, especially when used in dehumidifying applications. Hydronic versions are counterflow circuited for full gravity draining when installed level.

Correct installation will result in the typical bottom inlet on leaving air face and top outlet on entering air face of coil, a self-venting design. This will ensure cold air contact with cold water, and warm air with hot water.

Coil repositioning for opposite hand application will compromise one or more of these characteristics. However, there will be those situations where this may prove acceptable.

As a general rule, a change from counterflow circuiting to parallel flow for sensible heating and cooling applications will result in a 5% drop in net capacity per row of coil. In one and two row heating coils, the actual drop may not be measurable, thus of insignificant consequence.

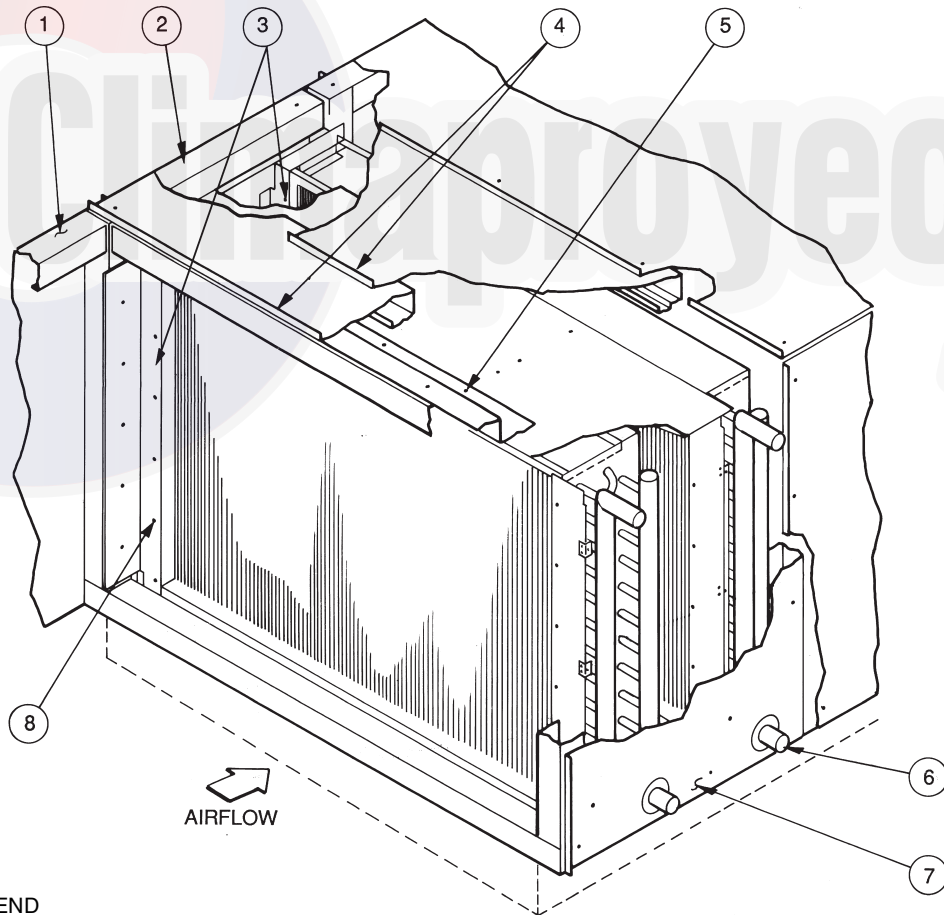

**LEGEND**

- |                          |                        |
|--------------------------|------------------------|
| 1 — Accessory Side Panel | 5 — Baffle Angle Screw |
| 2 — Left Side Panel      | 6 — Piping             |
| 3 — Inside Baffles       | 7 — Right Side Panel   |
| 4 — Top Panels           | 8 — Baffle Screw       |

**Fig. 50 — Horizontal or Vertical Unit — Vertical Coil Removal (39LB,LC,LF,LH Units)**

It is important that the airflow direction of the NuFin coil be adhered to when latent cooling is possible. Significant moisture carryover from the face of the dehumidifying coil will result if this rule is violated, even at very low face velocities. The same result is often experienced if after-market fin coatings are applied.

If a NuFin hydronic coil is installed with correct airflow, but opposite piping hand, and counterflow is maintained, steps must be taken to ensure that the coil is continuously vented, and that the water velocity is maintained to prevent the coil from air-binding.

Hot or cold areas of the coil face (or otherwise broad temperature differences and stratification) are usually indications that one or more circuits are air-locked internally. This can result in coil freeze-up (a condition NOT covered by warranty).

Refrigerant coils may be rotated for opposite hand applications, maintaining the proper airflow direction.

Do not reposition the distributor(s), they will perform equally well in upflow or downflow positions. When soldering expansion valves to up-feed distributors, use the minimum satisfactory amount of solder to prevent damaging the valve or plugging passages.

**DIRECT EXPANSION COILS** — Rotate the coil in vertical plane and reinstall. Distributor must be on downstream side of coil. (Refer to Fig. 51).

**CHILLED WATER AND HOT WATER COILS** — These coils can be rotated. If coil is rotated in vertical plane and reinstalled with counterflow maintained, supply will be at the top of the coil and return will be at the bottom. Ensure coil is continuously vented and water velocity is maintained to prevent air binding.

**⚠ CAUTION**

Chilled and hot water coils must not be rotated horizontally. If coils are rotated horizontally, severe water blow-off will result.

**STEAM INNER DISTRIBUTING TUBE COILS** — Rotate in horizontal plane and reinstall. See Fig. 51.

**PIPING** — Direct expansion, chilled water, and hot water coils should always be piped for counterflow. (Fluid should enter the coil at the leaving-air side.) Steam coils must have the condensate connection at bottom of coil.

To determine intervals for cleaning coils in contaminated air operations, pressure taps should be installed across the coils and checked periodically. Abnormal air pressure drop will indicate a need for cleaning the coils.

Annual maintenance should include:

1. Clean the line strainers.
2. Blow down the dirt leg.
3. Clean and check operation of steam traps.
4. Check operation of control valves.
5. Check the operation of check valves to prevent condensate flowback.
6. Check operation of thermostatic air vents, if used. A float and thermostatic trap will contain a thermostatic air vent. When the bellows is ruptured, it will fail closed.
7. Check operation of vacuum breakers.
8. Check operation of the thermal protection devices used for freeze-up protection.
9. Steam or condensate should not be allowed to remain in the coil during the off season. This will prevent the formation and build up of acids.

There are additional precautions and control strategies, as found in various catalogues and in the ASHRAE Fundamentals

Handbook and in the Carrier System Design Guide — Piping Section, when the entering-air temperature to the coil falls below 35 F. These conditions occur when IDT coils are used for pre-heat and/or face and bypass applications.

Freeze up protection:

1. Use a strainer in the supply line and the dirt leg ahead of the trap.

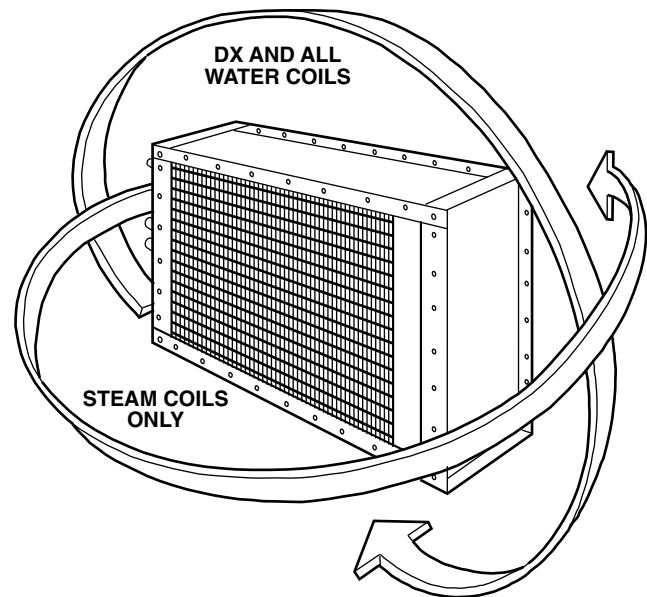

**Fig. 51 — Coil Rotation**

2. Use a vacuum breaker in the return.
3. Do not use overhead returns from the coil. A floodback can occur.
4. An immersion thermostat to control outdoor-air dampers and the fan motor is recommended. This control is activated when the steam supply fails or the condensate temperature drops below a predetermined temperature, usually 120 F.
5. On low pressure and vacuum systems, the immersion thermostat may be replaced by a condensate drain with a thermal element. This element opens and drains the coil when the condensate temperature drops below 165 F. Note the thermal condensate drain is limited to 5 psig pressure. At greater coil pressures they will not open.

In spite of the precautions listed above, a coil may still freeze up. An oversize capacity coil, at partial load, with a modulating steam control valve will occasionally freeze. Freezing occurs in the 20 F to 35 F range of entering-air temperatures. A better installation would be an undersize coil, with an on/off control valve with thermostatic control in the outside air, set at 35 F air temperature, installed downstream of the first coil; or setting the minimum steam pressure at 5 psig.

## Filters

**FILTER SECTIONS** — See Table 14 for filter data. Filters are field supplied.

Flat filter section can use 2-in. or 4-in. thick filters. The flat filter section as shipped accepts 2-in. filters. Remove spacer in each filter track to provide the 4-in. space required to accommodate 4-in. filters.

On all filter sections, filters are pushed into the track until they touch the opposite side of the unit. Any remaining space is taken up by the adjustable 2-piece sheet metal spacer. See Fig. 52 for filter arrangements.

## Fan Shaft Bearing Removal

1. Lock open and tag electrical disconnect.
2. Enter through fan section access door or remove panels as required.
3. Place plywood or other rigid covering on floor to protect insulation from damage.
4. Block wheel so that it will not pinwheel due to natural draft through the unit.
5. Loosen motor base to frame bolts. Adjust motor to release belt tension so removal of belts is done without stretching. *Do not stretch belts over sheaves. Damage to belt can result.*
6. Remove bolts on bushing of fan shaft sheave, insert bolts in jacking hole provided on bushing and slowly jack bushing from sheave. Then remove bushing on sheave.
7. Loosen bearing setscrews and locking collar.
8. Remove bearing holddown bolts.
9. Remove bearing while observing the following precautions:
  - a. Make certain fan shaft surface is not rough or scored. If so, clean up surface with fine emery cloth.

- b. Add a few drops of oil after cleanup of shaft end.

### ⚠ CAUTION

It should not be necessary to drive a new bearing onto shaft. If light tapping is needed, do not tap against outer race.

10. Check fan shaft diameter at bearing mount. If worn by more than .001 in. below nominal, shaft should be replaced.
11. Install new bearing, tighten holddown bolts and then tighten bearing locking collar and setscrews.
12. Make certain fan wheel does not rub sides of fan housing after installing new bearings.
13. Recoat fan shaft with a rust inhibitor or grease.
14. Replace sheave and belts. Adjust and align as described in Installation sections on installing sheaves and V-belts.
15. Remove insulation protection.
16. Replace access panels.
17. Restore electrical power.

**Table 14 — Filter Data**

39L UNIT SIZE	03	06	08	10	12	15	18	21	25
<b>Angle Filter Section</b>									
Filter Qty...Size (in.)	2...16x25	4...16x20	2...16x20 2...16x25	4...16x25	6...16x20	9...16x20	12...16x20	4...16x20 8...16x25	4...16x20 8...16x25
Nominal Face Area (sq ft)	5.56	8.89	10.00	11.11	13.33	20.00	26.67	31.11	31.11
<b>Filter Mixing Box Section</b>									
Filter Qty...Size (in.)	2...16x25	4...16x20	2...16x20 2...16x25	4...16x25	6...16x20	9...16x20	9...16x20	3...16x20 6...16x25	4...16x20 8...16x25
Nominal Face Area (sq ft)	5.56	8.89	10.00	11.11	13.33	20.00	20.00	23.33	31.11
<b>Flat Filter Section</b>									
Filter Qty...Size (in.)	2...16x16	2...20x20	2...20x25	2...16x25 1...20x25	3...20x25	6...16x20	3...16x20 3...20x20	3...20x25 3...16x25	2...16x20 2...20x20 2...20x25 2...16x25
Nominal Face Area (sq ft)	3.56	5.56	6.94	9.03	10.42	13.33	15.00	18.75	22.50

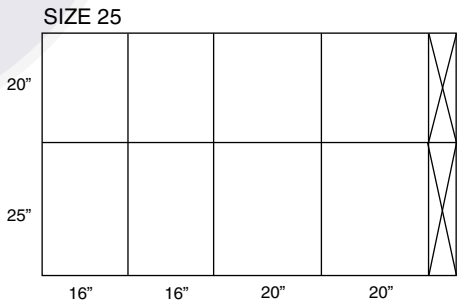
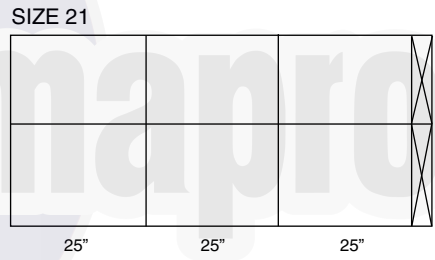
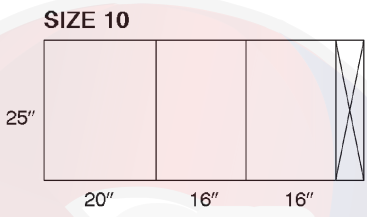
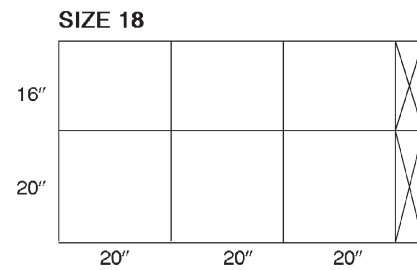
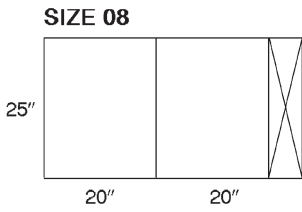
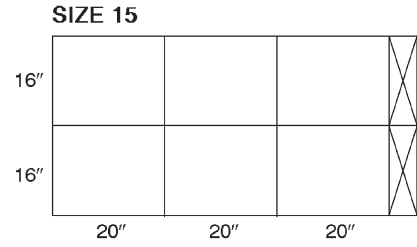
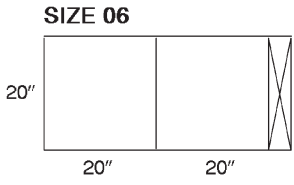
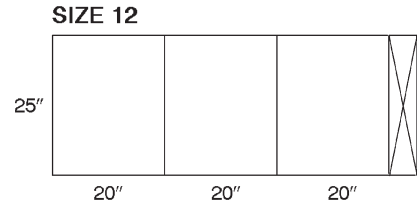
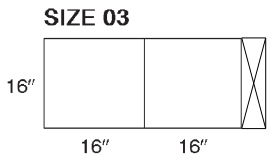
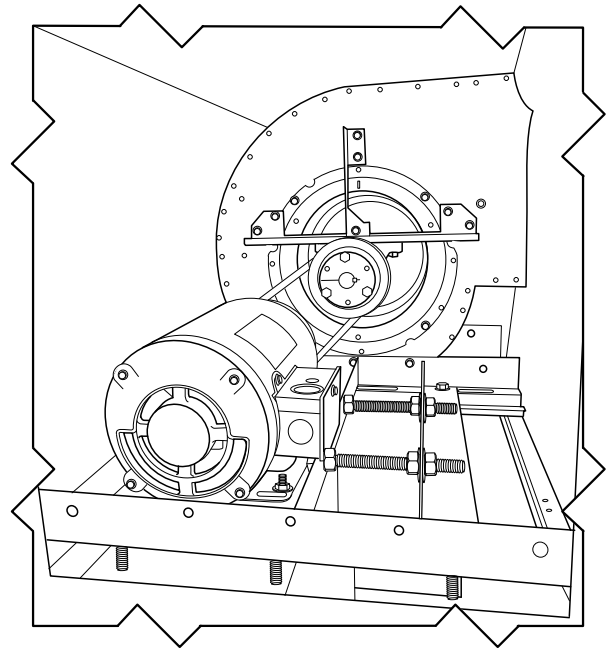

**Fig. 52 — Filter Arrangement, 2-in. and 4-in. Flat**

**Fan and Shaft Removal (Fig. 53)** — The fan wheel and shaft may be removed through inlet side of fan housing.

1. Remove drive belts as described in Fan Shaft Bearing Removal on page 43.
2. Block up fan wheel within housing to prevent dropping when bearing bolts are removed.
3. Loosen and remove bearing holddown bolts.
4. Remove bearing support channels and inlet ring from one side.
5. Remove fan shaft and fan wheel from unit.
6. Remove fan shaft from fan wheel.
7. Replace shaft and wheel into fan in the reverse order of their removal.
8. Inspect bearings and if serviceable, replace on shaft.
9. Align fan wheel and shaft assembly in fan scroll. Check cut-off location if wheel failure damaged cutoff plate. See Fig. 54.
10. Tighten bearing holddown bolts, bearing setscrews and shaft setscrews.
11. Field balancing of shaft and wheel is recommended.

**IMPORTANT:** Replacement shafts must have a diameter tolerance at bearing mount of  $\frac{+.0000}{-.001}$  nominal. Carrier-specified parts are recommended.



**Fig. 53 — Fan Shaft and Bearing Removal**

**Lubrication**

**MOTORS** — Lubricate in accordance with nameplate attached to motor or with manufacturer’s recommendations included with motor.

**BEARINGS**

**Fan Bearings** — Lubricate fan bearings every 3 months with suitable bearing grease. Typical lubricants are given in Table 15.

**Inlet Vane and Outlet Damper Bearings** — These bearings are oil-impregnated. Annually lubricate with a few drops of nondetergent SAE (Society of Automotive Engineers) 20 oil.

**Table 15 — Lubricant Data**

MANUFACTURER	LUBRICANT
Sunoco	Prestige 42
Texaco	Multipak 2
Texaco	Regal AFB-2*
Mobil	Mobilplex EP No. 1

\*Preferred lubricant because it contains rust and oxidation inhibitors.

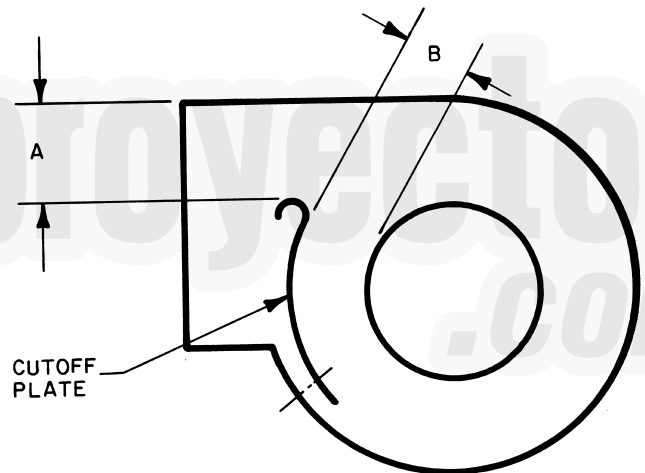

39L UNIT SIZE	CUTOFF A	CUTOFF CLEARANCE B
03	6 <sup>5</sup> / <sub>8</sub>	7/ <sub>8</sub>
06	8	1
08	10 <sup>3</sup> / <sub>8</sub>	1 <sup>1</sup> / <sub>2</sub>
10	9 <sup>3</sup> / <sub>4</sub>	1 <sup>3</sup> / <sub>8</sub>
12	9 <sup>3</sup> / <sub>4</sub>	1 <sup>3</sup> / <sub>8</sub>
15	12	1 <sup>5</sup> / <sub>8</sub>
18	15 <sup>3</sup> / <sub>4</sub>	2
21	15 <sup>3</sup> / <sub>4</sub>	2
25	20 <sup>1</sup> / <sub>2</sub>	2 <sup>11</sup> / <sub>16</sub>

**Fig. 54 — Fan Cutoff Plate Data (in.)**

**Fan Sled Disassembly** — in some cases on vertical units (39LD, 39 LF, or 39LH), it may be necessary to remove the fan sled (Fig. 55) from the unit and break it down into smaller components.

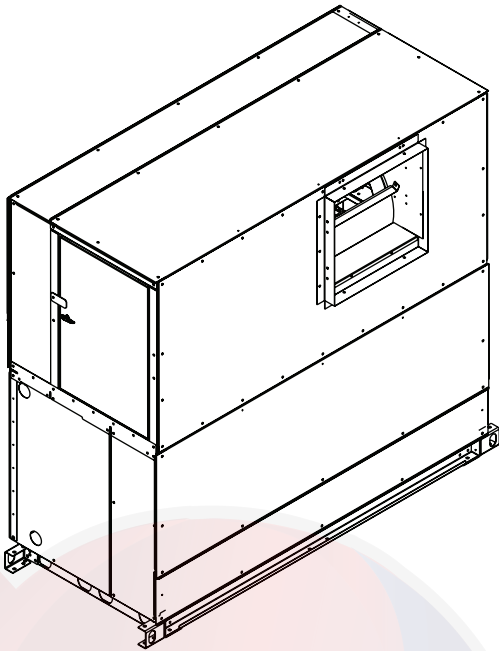
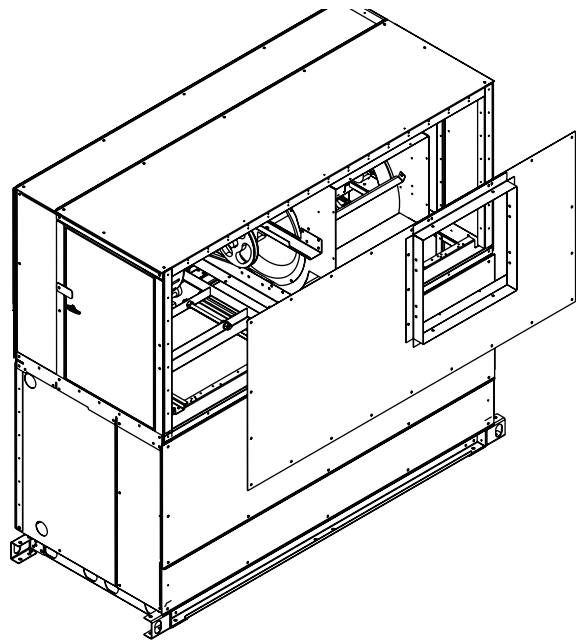

**Fig. 55 — Fan Sled**

To remove the fan sled:

1. Disconnect the fan discharge by removing the screws from the discharge of the fan housing. Remove the fan discharge panel (Fig. 56).
2. Remove all of the panels from the fan section (Fig. 57).
3. Remove the fan by removing the 4 screws on the corner of the fan sled. On larger units the fan sled may be extremely heavy. Affix appropriate rigging to remove the required components, noting on a diagram where each component is attached. See Fig. 58.

NOTE: Reinstall the components in reverse order.



**Fig. 57 — Remove All Panels**

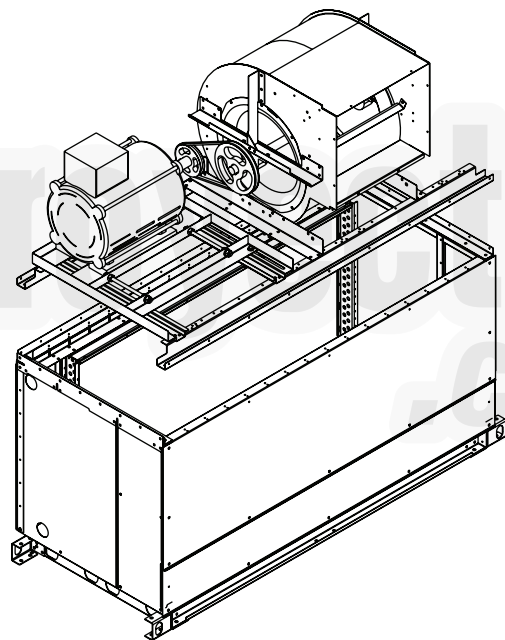

**Fig. 58 — Remove Fan**

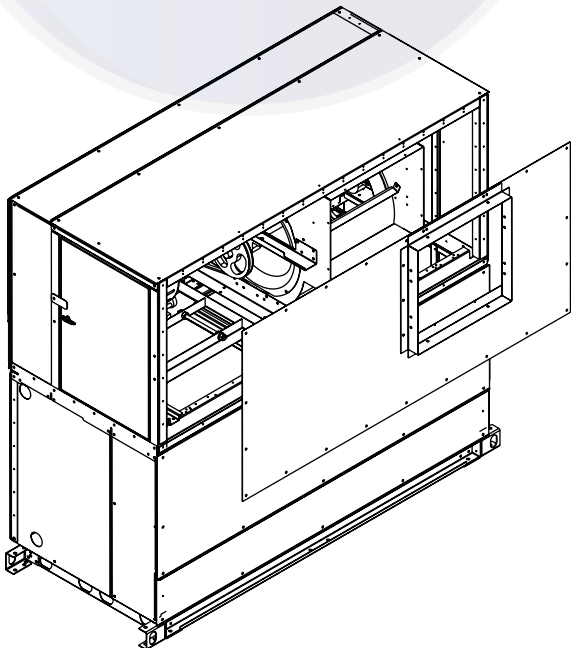

**Fig. 56 — Remove Fan Discharge Panel**

# METRIC CONVERSION CHART

METRIC TECH	X	= ENGLISH UNIT	X	= SI UNIT
<b>Area</b>				
cm <sup>2</sup>			100	mm <sup>2</sup>
cm <sup>2</sup>	0.1550	in <sup>2</sup>	645.2	mm <sup>2</sup>
m <sup>2</sup>			1.0	m <sup>2</sup>
m <sup>2</sup>	10.76	ft <sup>2</sup>	0.09290	m <sup>2</sup>
<b>Length</b>				
μ m			1.0	μ m
μ m	39.37	micro-inch	0.0254	μ m
mm			1.0	mm
mm	0.03937	in.	25.4	mm
mm	0.003281	ft	304.8	mm
m			1.0	m
m	3.281	ft	0.3048	m
m	1.094	yd	0.9144	m
<b>Mass</b>				
g			1.0	g
g	0.03527	oz	28.35	g
kg			1.0	kg
kg	2.205	lb	0.4536	kg
tonne, Mg			1.0	tonne, Mg
tonne, Mg	1.102	U.S. ton (2000 lb)	0.9072	tonne, Mg
<b>Power</b>				
kcal/h			1.163	W
kcal/h	3.968	Btu/h	0.2931	W
HP metric			0.7355	kW
HP metric	0.9863	HP (550 $\frac{ft \cdot lb}{S}$ )	0.7457	kW
Mcal/h			1.163	kW
Mcal/h	0.3307	Ton refr.	3.517	kW
<b>Pressure</b>				
mm w.g. 4°C			9.806	Pa
mm w.g. 4°C	0.03937	in H <sub>2</sub> O 39.2°F	249.1	Pa
mm Hg 0°C			0.1333	kPa
mm Hg 0°C	0.03937	in Hg 32°F	3.386	kPa
kg <sub>f</sub> /cm <sup>2</sup>			98.07	kPa
kg <sub>f</sub> /cm <sup>2</sup>	14.22	psi	6.895	kPa
mH <sub>2</sub> O	3.281	ft H <sub>2</sub> O	2.989	kPa

METRIC TECH	X	= ENGLISH UNIT	X	= SI UNIT
<b>Temperature Interval</b>				
°C			1.0	K
°C	1.8	°F	0.5556	°C
<b>Velocity</b>				
m/s			1.0	m/s
m/s	3.281	ft/s	0.3048	m/s
m/s	196.9	ft/min	0.00508	m/s
<b>Volume</b>				
mm <sup>3</sup>			1.0x10 <sup>-6</sup>	L
mm <sup>3</sup>	6.102x10 <sup>-5</sup>	in. <sup>3</sup>	0.01639	L
L			1.0	L
L	0.03531	ft <sup>3</sup>	28.32	L
m <sup>3</sup>			1.0	m <sup>3</sup>
m <sup>3</sup>	1.308	yd <sup>3</sup>	0.7646	m <sup>3</sup>
L	0.2642	U.S. gal	3.785	L
L	2.113	U.S. pint	0.4732	L
mL, cm <sup>3</sup>			1.0	mL
mL, cm <sup>3</sup>	0.03381	U.S. oz	29.57	mL
<b>Volume/Time</b>				
m <sup>3</sup> /h			0.2778	L/s
m <sup>3</sup> /h	0.5886	ft <sup>3</sup> /min	0.4719	L/s
m <sup>3</sup> /h	4.403	U.S. gal/min	0.06309	L/s
L/h			2.778x10 <sup>-4</sup>	L/s
L/h	4.403x10 <sup>-3</sup>	U.S. gal/min	0.06309	L/s
(m <sup>3</sup> /h)/ (1000 kcal/h)	1.780	cfm/ton	0.1342	L/s · kW

METRIC TECH	CONVERSION FACTOR	= ENGLISH UNIT	CONVERSION FACTOR	= SI UNIT
<b>Temperature</b>				
°C			°C + 273.15	K
°C	(°C x 1.8) + 32	°F	(°F - 32) ÷ 1.8	°C

PREFIXES		
M	MEGA-	10 <sup>6</sup>
k	KILO-	10 <sup>3</sup>
d	DECI	10 <sup>-1</sup>
c	CENTI	10 <sup>-2</sup>
m	MILLI	10 <sup>-3</sup>
μ	MICRO	10 <sup>-6</sup>

LEGEND	
m	METER
cal	CALORIE
kg	KILOGRAM (mass)
kgf	KILOGRAM — FORCE
kp	KILOGRAM — FORCE
L	LITER
°C	DEGREES CELSIUS
K	KELVIN
W	WATT
Pa	PASCAL
J	JOULE
N	NEWTON
h	HOUR

UNITS	
cP	CENTIPOISE
cSt	CENTISTOKE
HP metric =	(PS, CV, ch) METRIC HORSEPOWER
mm w.g.	MILLIMETERS WATER GAUGE
mm CE	MILLIMETERS WATER GAUGE
mm Hg	MILLIMETERS MERCURY
tonne =	1000 kg
kcal =	fg FRIGORIE
bar =	100 kPa

