

50HC

Single Package Rooftop Electric Cooling Unit
with Puron (R-410A) Refrigerant
3 to 12.5 Nominal Tons (Sizes 04-14)



Service and Maintenance Instructions

TABLE OF CONTENTS

SAFETY CONSIDERATIONS	1
UNIT ARRANGEMENT AND ACCESS	2
SUPPLY FAN (BLOWER) SECTION	4
STAGED AIR VOLUME CONTROL -2 SPEED FAN WITH VARIABLE FREQUENCY DRIVE (VFD)	7
ADDITIONAL VARIABLE FREQUENCY DRIVE (VFD) INSTALLATION AND TROUBLESHOOTING.	8
MOTOR	8
COOLING	12
THERMOSTATIC EXPANSION VALVE (TXV)	14
PURON® (R-410A) REFRIGERANT	15
COOLING CHARGING CHARTS	17
COMPRESSOR	21
CONVENIENCE OUTLETS	24
SMOKE DETECTORS	25
SENSOR AND CONTROLLER TESTS	29
PROTECTIVE DEVICES	32
PREMIERLINK™ CONTROL	33
RTU-OPEN CONTROL SYSTEM	33
SENSORY/ACCESSORY INSTALLATION	34
ADDITIONAL RTU-OPEN INSTALLATION AND TROUBLESHOOTING	34
ECONOMIZER UNITS	36
PRE-START-UP/START-UP	44
START-UP, GENERAL	45
START-UP, PREMIERLINK™ CONTROLS	46
START-UP, RTU-OPEN CONTROLS	46
FASTENER TORQUE VALUES	47
APPENDIX I. MODEL NUMBER SIGNIFICANCE .	48
APPENDIX II. PHYSICAL DATA	49
APPENDIX III. FAN PERFORMANCE	52
APPENDIX IV WIRING DIAGRAMS	71
APPENDIX V. MOTORMASTER SENSOR LOCATIONS	121
UNIT START-UP CHECKLIST	124

SAFETY CONSIDERATIONS

Installation and servicing of air-conditioning equipment can be hazardous due to system pressure and electrical components. Only trained and qualified service personnel should install, repair, or service air-conditioning equipment. Untrained personnel can perform the basic maintenance functions of replacing filters. Trained service personnel should perform all other operations.

When working on air-conditioning equipment, observe precautions in the literature, tags and labels attached to the unit, and other safety precautions that may apply. Follow all safety codes. Wear safety glasses and work gloves. Use quenching cloth for unbrazing operations. Have fire extinguishers available for all brazing and unbrazing operations.

Read these instructions thoroughly and follow all warnings or cautions attached to the unit. Consult local building codes and National Electrical Code (NEC) for special requirements.

Recognize safety information. This is the safety ALERT symbol . When you see this symbol on the unit and in instructions or manuals, be aware of the potential for physical injury hazards.

Understand the signal words **DANGER**, **WARNING**, and **CAUTION**. These words are used with the safety-ALERT symbol. **DANGER** indicates a hazardous situation which, if not avoided, **will** result in death or severe personal injury. **WARNING** indicates a hazardous situation which, if not avoided, **could** result in death or personal injury. **CAUTION** indicates a hazardous situation which, if not avoided, **could** result in minor to moderate injury or product and property damage. **NOTICE** is used to address practices not related to physical injury. **NOTE** is used to highlight suggestions which **will** result in enhanced installation, reliability, or operation.

⚠ WARNING

ELECTRICAL OPERATION HAZARD

Failure to follow this warning could result in personal injury or death.

Before performing service or maintenance operations on unit, LOCK-OUT/TAGOUT the main power switch to unit. Electrical shock and rotating equipment could cause severe injury.

⚠ WARNING

ELECTRICAL OPERATION HAZARD

Failure to follow this warning could result in personal injury or death.

Units with convenience outlet circuits can use multiple disconnects. Check convenience outlet for power status before opening unit for service. Locate the disconnect switch and lock it in the open position it. LOCK-OUT/TAGOUT this switch to notify others.

⚠ WARNING

UNIT OPERATION AND SAFETY HAZARD

Failure to follow this warning could cause personal injury, death and/or equipment damage.

Puron (R-410A) refrigerant systems operate at higher pressures than standard R-22 systems. Do not use R-22 service equipment or components on Puron refrigerant equipment.

⚠ WARNING

FIRE, EXPLOSION HAZARD



Failure to follow this warning could result in death, serious personal injury and/or property damage.

Never use air or gases containing oxygen for leak testing or for operating refrigerant compressors. Pressurized mixtures of air or gases containing oxygen can lead to an explosion.

⚠ WARNING

FIRE, EXPLOSION HAZARD



Failure to follow this warning could result in death, serious personal injury and/or property damage.

Never use non-certified refrigerants in this product. Non-certified refrigerants could contain contaminants that could lead to unsafe operating conditions. Use ONLY refrigerants that conform to AHRI Standard 700.

⚠ CAUTION

UNIT DAMAGE HAZARD

Failure to follow this caution may result in reduced unit performance or unit shutdown.

High velocity water from a pressure washer, garden hose, or compressed air should never be used to clean a coil. The force of the water or air jet will bend the fin edges and increase airside pressure drop.

NOTICE

OPERATIONAL TEST ALERT

Failure to follow this ALERT can result in an unnecessary evacuation of the facility.

Pressing the controller's test/reset switch for longer than seven seconds will put the duct detector into the alarm state and activate all automatic alarm responses.

IMPORTANT: Lockout/Tagout is a term used when electrical power switches are physically locked preventing power to the unit. A placard is placed on the power switch alerting service personnel that the power is disconnected.

UNIT ARRANGEMENT AND ACCESS

General

Fig. 1 and Fig. 2 show general unit arrangement and access locations.

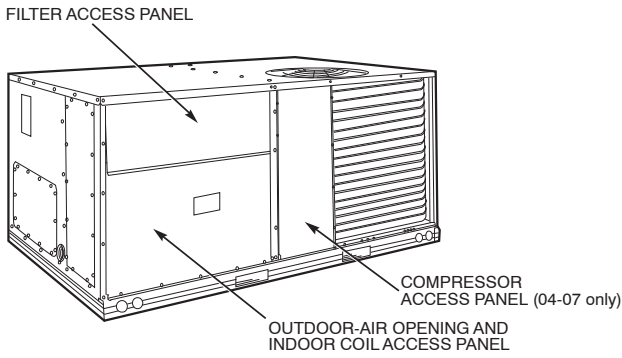

C08449

Fig. 1 - Typical Access Panel Locations

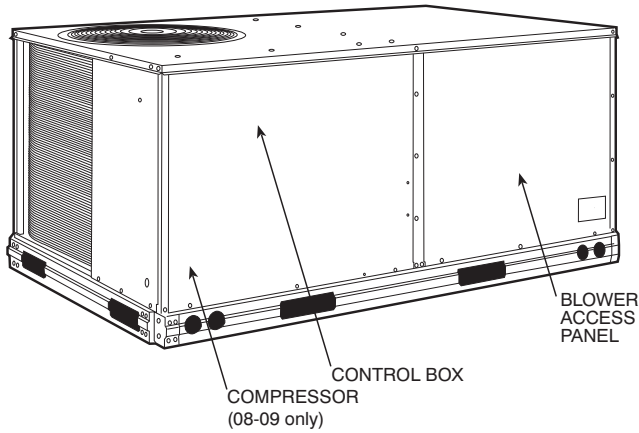

C160062

Fig. 2 - Blower Access Panel Location

Routine Maintenance

These items should be part of a routine maintenance program, to be checked every month or two, until a specific schedule for each can be identified for this installation:

Quarterly Inspection (and 30 days after initial start)

- Return air filter replacement
- Outdoor hood inlet filters cleaned
- Belt tension and condition checked
- Pulley alignment checked
- Fan shaft bearing locking collar tightness checked
- Condenser coil cleanliness checked
- Condensate drain checked

Seasonal Maintenance

These items should be checked at the beginning of each season (or more often if local conditions and usage patterns dictate):

Air Conditioning

- Condenser fan motor mounting bolts tightness
- Compressor mounting bolts
- Condenser fan blade positioning
- Control box cleanliness and wiring condition
- Wire terminal tightness
- Refrigerant charge level using chart
- Evaporator coil cleaning
- Evaporator blower and condenser motor amperage

Economizer or Outside Air Damper

- Inlet filters condition
- Check damper travel (economizer)
- Check gear and dampers for debris and dirt

Air Filters and Screens

Each unit is equipped with return air filters. If the unit has an economizer, it will also have an outside air screen. If a manual outside air damper is added, an inlet air screen will also be present.

Each of these filters and screens will need to be periodically replaced or cleaned.

50HC

SUPPLY FAN (BLOWER) SECTION

⚠ WARNING

ELECTRICAL SHOCK HAZARD

Failure to follow this warning could cause personal injury or death.

Before performing service or maintenance operations on unit, **LOCK-OUT/TAGOUT** the main power switch to unit. Electrical shock and rotating equipment could cause severe injury.

Supply Fan (Direct-Drive)

For unit sizes 04, 05 and 06, a direct-drive forward-curved centrifugal blower wheel is an available option. The motor has taps to provide the servicer with the selection of one of five motor torque/speed ranges to best match wheel performance with attached duct system. See Fig. 3 and Fig. 4 .

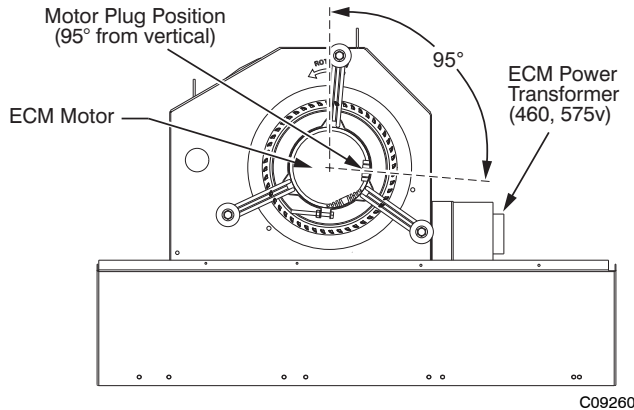

Fig. 3 - Direct-Drive Supply Fan Assembly

ECM Motor — The direct-drive motor is an X13 Electronically Commutated Motor (ECM). An ECM motor contains electronic circuitry used to convert single-phase line AC voltage into 3-phase DC voltage to power the motor circuit. The motor circuit is a DC brushless design with a permanent magnet rotor. On the X13 ECM Motor design, the electronic circuitry is integral to the motor assembly and cannot be serviced or replaced separately.

208/230V units use a 230V motor. 460V units use a 230V motor with a stepdown transformer (mounted on the end of the fan housing, see Fig. 3). 575V units use a 460V motor with an autotransformer. Motor power voltage is

connected to motor terminals L and N (see Fig. 4 and Fig. 5); ground is connected at terminal G. The motor power voltage is **ALWAYS** present; it is not switched off by a motor contactor.

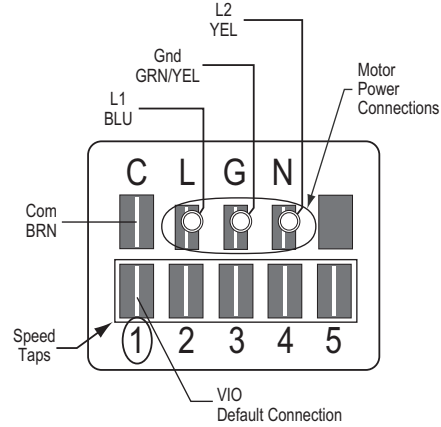

Fig. 4 - ECM Motor Connectors

C09261

Evaluating motor speed — The X13 ECM Motor uses a constant torque motor design. The motor speed is adjusted by the motor control circuitry to maintain the programmed shaft torque. Consequently there is no specific speed value assigned to each control tap setting. At the Position 5 tap, the motor speed is approximately 1050 RPM (17.5 r/s) but varies depending on fan wheel loading.

Selecting speed tap — The five communication terminals are each programmed to provide a different motor torque output. See Table 1. Factory default tap selection is Position 1 for lowest torque/speed operation.

**Table 1 – Motor Tap Programing
(percent of full-load torque)**

Unit Size	Tap 1	Tap 2	Tap 3	Tap 4	Tap 5
04	32	38	45	50	100
05	46	58	61	69	100
06	73	82	85	90	100

Factory Default: Tap 1 (VIO)

Selecting another speed:

1. Disconnect main power to the unit. Apply lockout/tagout procedures.
2. Remove the default motor signal lead (VIO) from terminal 1 at the motor communications terminal.
3. Reconnect the motor signal lead to the desired speed (terminals 1 through 5).
4. Connect main power to the unit.

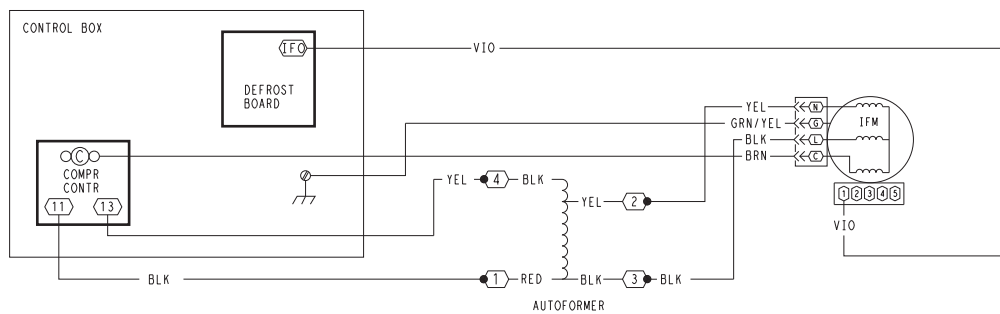

460, 575-v Units

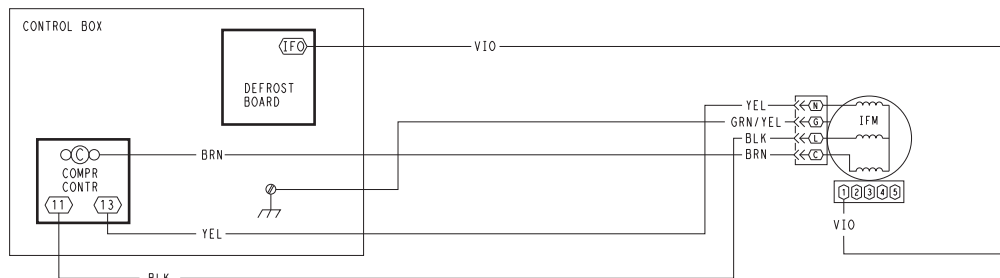

208/230-v Units

Fig. 5 - Direct-Drive Supply Fan Assembly

C09260

50HC

Motor “rocking” on start-up — When the motor first starts, the rotor (and attached wheel) will “rock” back and forth as the motor tests for rotational direction. Once the correct rotational direction is determined by the motor circuitry, the motor will ramp up to the specified speed. The “rocking” is a normal operating characteristic of ECM motors.

Troubleshooting the ECM motor — Troubleshooting the X13 ECM requires a voltmeter.

1. Disconnect main power to the unit.
2. Remove the motor power plug (including the control BRN lead) and VIO control signal lead at the motor terminals.
3. Restore main unit power.
4. Check for proper line voltage at motor power leads BLK (at L terminal) and YEL (at N terminal). See Table 2.

Table 2 – Motor Test Volts

Unit Voltage	Motor Voltage	Min–Max Volts
208/230	230	190–250
460	230	210–250
575	460	420–500

5. Using a jumper wire from unit control terminals R to G, engage motor operation. Check for 24v output at the defrost board terminal IFO.
6. Check for proper control signal voltages of 22V to 28V at motor signal leads VIO and BRN.
7. Disconnect unit main power. Apply lockout/tagout procedures.
8. Reconnect motor power and control signal leads at the motor terminals.

9. Restore unit main power.
10. The motor should start and run. If the motor does not start, remove the motor assembly. Replace the motor with one having the same part number. Do not substitute with an alternate design motor as the torque/ speed programming will not be the same as that on an original factory motor.

Replacing the X-13 ECM Motor — Before removing the ECM belly-band mounting ring from old motor:

1. Measure the distance from base of the motor shaft to the edge of the mounting ring.
2. Remove the motor mounting band and transfer it to the replacement motor.
3. Position the mounting band at the same distance that was measured in Step 1.
4. Hand-tighten mounting bolt only. Do not tighten securely at this time.
5. Insert the motor shaft into the fan wheel hub.
6. Securely tighten the three motor mount arms to the support cushions and torque the arm mounting screws to 60 in-lbs (6.8 Nm).
7. Center the fan wheel in the fan housing. Tighten the fan wheel hub setscrew and torque to 120 in-lbs (13.6 Nm).
8. Ensure the motor terminals are located at a position below the 3 o’clock position (see Fig. 3). Tighten the motor belly-band bolt and torque to 80 in-lbs (9.0 Nm).

Supply Fan (Belt-Drive)

The belt-drive supply fan system consists of a forward-curved centrifugal blower wheel on a solid shaft with two concentric type bearings, one on each side of the

blower housing. A fixed-pitch driven pulley is attached to the fan shaft and an adjustable-pitch driver pulley is on the motor. The pulleys are connected using a V-belt. (See Fig. 6.).

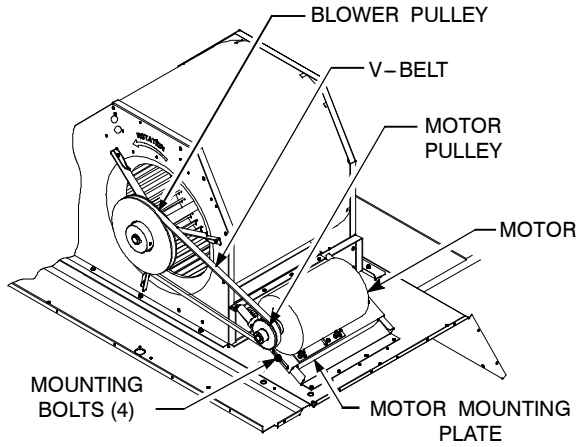

Fig. 6 - Typical Belt Drive Motor Mounting

Belt

Check the belt condition and tension quarterly. Inspect the belt for signs of cracking, fraying or glazing along the inside surfaces. Check belt tension by using a spring-force tool, such as Browning's "Belt Tension Checker" (p/n: 1302546 or equivalent tool); tension should be 6-lbs at a $\frac{5}{8}$ -in (1.6 cm) deflection when measured at the centerline of the belt span. This point is at the center of the belt when measuring the distance between the motor shaft and the blower shaft.

NOTE: Without the spring-tension tool, place a straight edge across the belt surface at the pulleys, then push down on the belt at mid-span using one finger until a $\frac{1}{2}$ -in. (1.3 cm) deflection is reached. See Fig. 7.

Adjust belt tension by loosening the motor mounting plate front and rear bolts and sliding the plate toward the fan (to reduce tension) or away from fan (to increase tension). Ensure the blower shaft and the motor shaft are parallel to each other (pulleys aligned). When finished, tighten all bolts and torque to 65-70 in-lb (7.4 to 7.9 Nm).

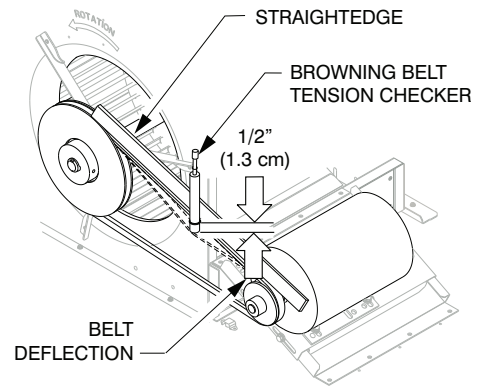

Fig. 7 - Checking Blower Motor Belt Tension

Replacing the Belt:

NOTE: Use a belt with same section type or similar size. Do not substitute a FHP-type belt. When installing the new belt, do not use a tool (screwdriver or pry-bar) to force the belt over the pulley flanges, this will stress the belt and cause a reduction in belt life. Damage to the pulley can also occur.

Use the following steps to replace the V-belt. See Fig. 6.

1. Loosen the front and rear motor mounting plate bolts.
2. Push the motor and its mounting plate towards the blower housing as close as possible to reduce the center distance between fan shaft and motor shaft.
3. Remove the belt by gently lifting the old belt over one of the pulleys.
4. Install the new belt by gently sliding the belt over both pulleys and then sliding the motor and plate away from the fan housing until proper tension is achieved.

CAUTION

EQUIPMENT DAMAGE HAZARD

Failure to follow this CAUTION can result in premature wear and damage to equipment.

Do not use a screwdriver or a pry bar to place the new V-belt in the pulley groove. This can cause stress on the V-belt and the pulley resulting in premature wear on the V-belt and damage to the pulley.

5. Check the alignment of the pulleys, adjust if necessary.
6. Tighten all bolts and torque to 65-70 in-lb (7.4 to 7.9 Nm).
7. Check the tension after a few hours of runtime and re-adjust as required.

Adjustable-Pitch Pulley on Motor

The motor pulley is an adjustable-pitch type that allows a servicer to implement changes in the fan wheel speed to match as-installed ductwork systems. The pulley consists of a fixed flange side that faces the motor (secured to the motor shaft) and a movable flange side that can be rotated

around the fixed flange side that increases or reduces the pitch diameter of this driver pulley. (See Fig. 8.)

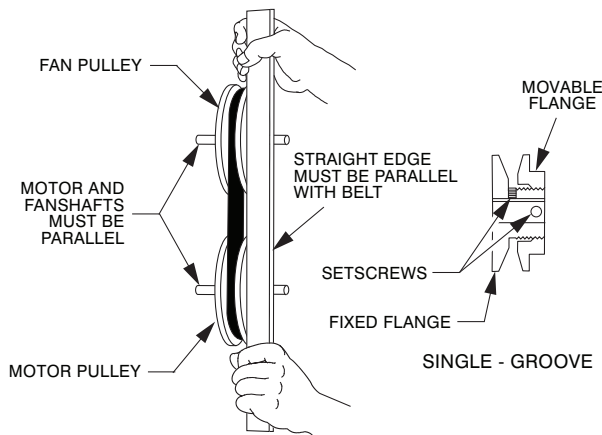

Fig. 8 - Supply-Fan Pulley Adjustment

C07075

As the pitch diameter is changed by adjusting the position of the movable flange, the centerline on this pulley shifts laterally (along the motor shaft). This creates a requirement for a realignment of the pulleys after any adjustment of the movable flange. Reset the belt tension after each realignment.

Inspect the condition of the motor pulley for signs of wear. Glazing of the belt contact surfaces and erosion on these surfaces are signs of improper belt tension and/or belt slippage. Replace pulley if wear is excessive.

Changing the Fan Speed:

1. Shut off unit power supply. Use proper lockout/tagout procedures.
2. Loosen belt by loosening fan motor mounting nuts. (See Fig. 6.)
3. Loosen movable pulley flange setscrew. (See Fig. 8.)
4. Screw movable flange toward fixed flange to increase speed and away from fixed flange to decrease speed. Increasing fan speed increases load on motor. Do not exceed the maximum specified speed.
5. Set movable flange at nearest keyway of pulley hub. Tighten setscrew and torque to 65-70 in-lb (7.4 to 7.9 Nm).

Aligning Blower and Motor Pulleys:

1. Loosen blower pulley setscrews.
2. Slide blower pulley along blower shaft. Make angular alignment by loosening motor mounting plate front and rear bolts.
3. Tighten blower pulley setscrews and motor mounting bolts. Torque bolts to 65-70 in-lb (7.4 to 7.9 Nm).
4. Recheck belt tension.

Bearings

The fan system uses bearings featuring concentric split locking collars. A Torx T-25 socket head cap screw is used to tighten the locking collars. Tighten the locking collar by holding it tightly against the inner race of the bearing. Tighten the socket head cap screw. Torque cap screw to 65-70 in-lb (7.4-7.9 Nm). See Fig. 9. Check the

condition of the motor pulley for signs of wear. Glazing of the belt contact surfaces and erosion on these surfaces are signs of improper belt tension and/or belt slippage. Pulley replacement can be necessary.

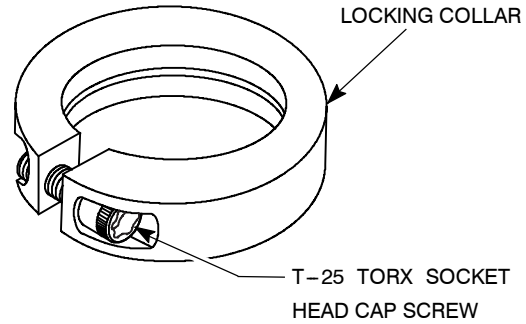

Fig. 9 - Tightening Locking Collar

C11505

STAGED AIR VOLUME CONTROL - 2 SPEED FAN WITH VARIABLE FREQUENCY DRIVE (VFD)

Staged Air Volume (SAV) Indoor Fan Speed System

The Staged Air Volume (SAV) system utilizes a Fan Speed control board and Variable Frequency Drive (VFD) to automatically adjust the indoor fan motor speed in sequence with the unit's ventilation, cooling and heating operation. Per ASHRAE 90.1 2010 standard section 6.4.3.10.b, during the first stage of cooling operation the SAV system will adjust the fan motor to provide two-thirds (2/3) of the design airflow rate for the unit. When the call for the second stage of cooling is required, the SAV system will allow the design airflow rate for the unit established (100%). During the heating mode, the SAV system will allow total design airflow rate (100%) operation. During ventilation mode, the SAV system will operate the fan motor at 2/3 speed.

Identifying Factory Option

This supplement only applies to units that meet the criteria detailed in Table 3. If the unit does not meet that criteria, discard this document.

Table 3 – Model-Size / VFD Option Indicator

Model / Sizes	Position in Model Number	VFD FIOP Indicator
50HC / 08-28	17	G, J

NOTE: See Fig. 57 for an example of Model Number Nomenclature.

Unit Installation with SAV Option

50HC Rooftop — Refer to the base unit installation instructions for standard required operating and service clearances.

NOTE: The Remote VFD Keypad is a field-installed option. It is not included as part of the Factory installed VFD option.

See “*Variable Frequency Drive (VFD) Installation, Setup and Troubleshooting Supplement*” for wiring schematics and performance charts and configuration.

See Figs 10, 11 and 12 for locations of the Variable Frequency Drive (VFD) as mounted on the various 50HC models.

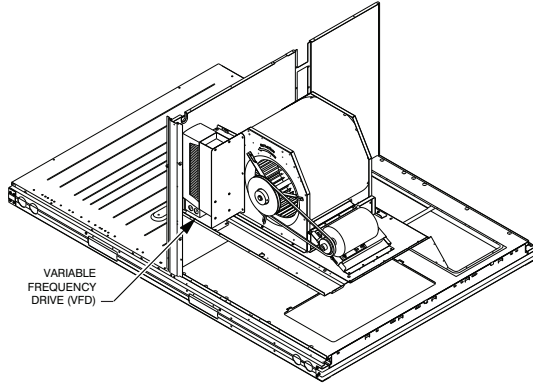

Fig. 10 - VFD Location for size 08-09

C11528

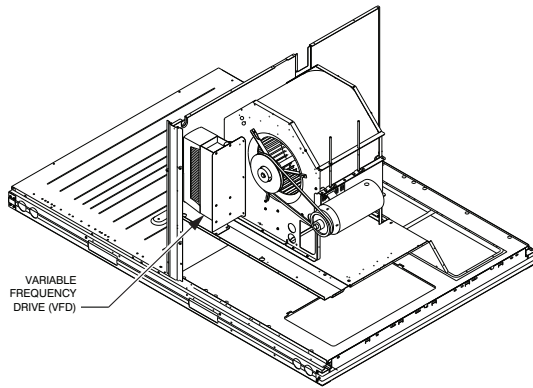

Fig. 11 - VFD Location for size 12

C11529

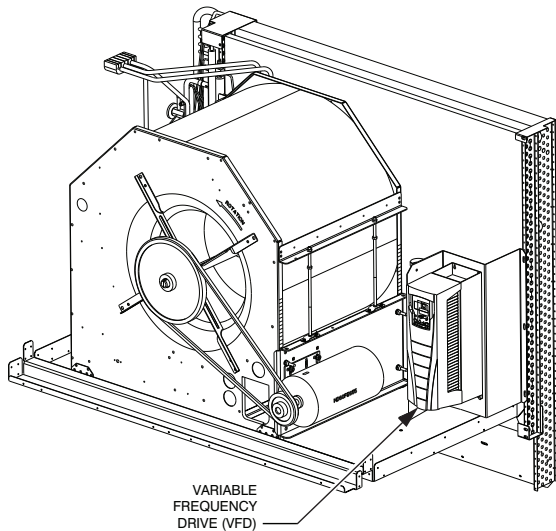

Fig. 12 - VFD Location for size 14

C11530

ADDITIONAL VARIABLE FREQUENCY DRIVE (VFD) INSTALLATION AND TROUBLESHOOTING

Additional installation, wiring and troubleshooting information for the Variable Frequency Drive can be found in the following manuals: “*Variable Frequency Drive (VFD) Installation, Setup and Troubleshooting Supplement.*”

MOTOR

When replacing the motor, use the following steps. See Fig. 13.

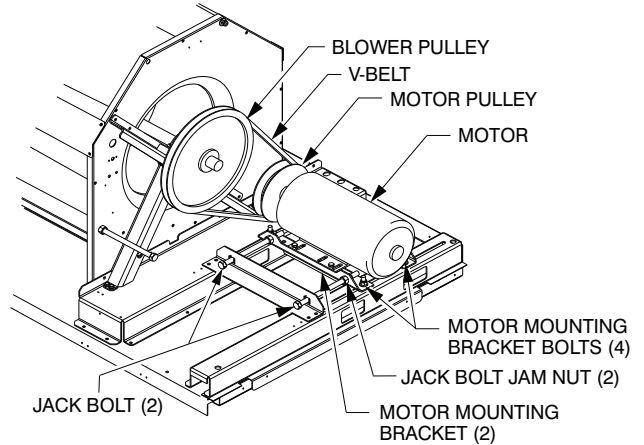

C12034

Fig. 13 - Replacing Belt Driven Motor

Replacing the Motor

Use the following steps to replace the belt-driven motor.

1. Turn off all electrical power to the unit. Use approved lockout/tagout procedures on all electrical power sources.
2. Remove cover on motor connection box.
3. Disconnect all electrical leads to the motor.
4. Loosen the two jack bolt jamnuts on the motor mounting bracket.
5. Turn two jack bolts counterclockwise until motor assembly moves closer to blower pulley.
6. Remove V-belt from blower pulley and motor pulley.

⚠ CAUTION

EQUIPMENT DAMAGE HAZARD

Failure to follow this CAUTION can result in premature wear and damage to equipment.

Do not use a screwdriver or a pry bar to place the new V-belt in the pulley groove. This can cause stress on the V-belt and the pulley resulting in premature wear on the V-belt and damage to the pulley.

7. Loosen the four mounting bracket bolts and lock washers.
8. Remove four bolts, four flat washers, four lock washers and four nuts attaching the motor mounting

plate to the unit. Discard all lock washers.

9. Remove motor and motor mounting bracket from unit.
10. Remove four bolts, flat washers, lock washers and single external-tooth lock washer attaching motor to the motor mounting plate. Discard all lock washers and external-tooth lock washer.
11. Lift motor from motor mounting plate and set aside.
12. Slide motor mounting band from old motor.
13. Slide motor mounting band onto new motor and set motor onto the motor mounting plate.
14. Remove variable pitch pulley from old motor and attach it to the new motor.
15. Inspect variable pitch pulley for cracks and wear. Replace the pulley if necessary.
16. Secure the pulley to the motor by tightening the pulley setscrew to the motor shaft.
17. Insert four bolts and flat washers through mounting holes on the motor into holes on the motor mounting plate.
18. On one bolt, place a new external-tooth lock washer between the motor and motor mounting band.
19. Ensure the teeth of the external-tooth lock washer make contact with the painted base of the motor. This washer is essential for properly grounding motor.
20. Install four new lock washers and four nuts on the bolts on the bottom of the motor mounting plate.
21. Do Not tighten the mounting bolts at this time.
22. Set new motor and motor mounting bracket back onto the unit. See Fig. 13.
23. Install four bolts, four flat washers, four new lock washers and four nuts attaching the motor assembly to the unit.
24. Do Not tighten the mounting bolts at this time.
25. Install motor drive V-belt to motor pulley and blower wheel pulley. See CAUTION.
26. Align the motor pulley and blower wheel pulley using a straight edge. See Fig. 8.
27. Adjust the V-belt tension using adjustment tool.
28. Turn two jack bolts clockwise, moving the motor assembly away from the blower pulley, increasing the V-belt tension.
29. Tighten the four bolts securing the motor mounting brackets to the unit. Torque four bolts to 120 ± 12 in-lbs (14 ± 1.4 Nm).
30. Remove cover on motor connection box.
31. Re-connect all electrical leads to the motor and replace the connection box cover.
32. Re-connect all electrical power to the unit. Remove lockout tags on all electrical power sources.
33. Start unit and allow to run for a designated period.
34. Shut off unit and make any necessary adjustments to the V-belt tension or the motor and blower wheel pulley alignment.

When replacing the motor, also replace the external-tooth lock washer (star washer) under the motor mounting base; this is part of the motor grounding system. Ensure the

teeth on the lock washer are in contact with the motor's painted base. Tighten motor mounting bolts to 120 ± 12 in-lbs.

Changing Fan Wheel Speed

Changing fan wheel speed by changing pulleys: The horsepower rating of the belt is primarily dictated by the pitch diameter of the smaller pulley in the drive system (typically the motor pulley in these units). Do not install a replacement motor pulley with a smaller pitch diameter than provided on the original factory pulley. Change fan wheel speed by changing the fan pulley (larger pitch diameter to reduce wheel speed, smaller pitch diameter to increase wheel speed) or select a new system (both pulleys and matching belt).

Before changing pulleys to increase fan wheel speed, check the fan performance at the target speed and airflow rate to determine new motor loading (bhp). Use the fan performance tables or use the Packaged Rooftop Builder software program. Confirm that the motor in this unit is capable of operating at the new operating condition. Fan shaft loading increases dramatically as wheel speed is increased.

To reduce vibration, replace the motor's adjustable pitch pulley with a fixed pitch pulley (after the final airflow balance adjustment). This will reduce the amount of vibration generated by the motor/belt-drive system.

REMOTE VFD KEYPAD REFERENCE

Table 4 – SRT Unit VFD Parameters — 50HC 08-12**

VFD Part Number	ABB Part Number	Description	Motor Part Number	Voltage (9905)	Nom Amps (9906)	Motor Nom Freq (9907)	Nom RPM (9908)	Nom HP (9909)	Const Speed Sel (1201)	Const Speed 1 (1202)	Const Speed 2 (1203)	Const Speed 3 (1204)	Relay Out 3 (1403)	Max Amps (2003)	Min Freq (2007)	Max Freq (2008)	Switch Freq (2006)	Start Fcn (2101)	Stop Fcn (2102)	Accel/Decel (2201)	Accel (2202)	Decel (2203)
HK30WA352	ACH550-U0-012A-2	1.7 HP 230V	HD56FR283	230	5.8	60Hz	1725	1.7	D12.3	40Hz	60Hz	60Hz	16 FLT/ Alarm	6.7	0Hz	60Hz	4kHz	Ramp	Not Sel	30 sec	30 sec	30 sec
HK30WA356	ACH550-U0-06A9-4	1.7 HP 460V	HD56FR463	460	2.9	60Hz	1725	1.7	D12.3	40Hz	60Hz	60Hz	16 FLT/ Alarm	3.3	0Hz	60Hz	4kHz	Ramp	Not Sel	30 sec	30 sec	30 sec
HK30WA360	ACH550-U0-03A9-6	1.7 HP 575V	HD56FR579	575	3.1	60Hz	1725	1.7	D12.3	40Hz	60Hz	60Hz	16 FLT/ Alarm	3.6	0Hz	60Hz	4kHz	Ramp	Not Sel	30 sec	30 sec	30 sec
HK30WA352	ACH550-U0-012A-2	2.4 HP 230V	HD56FE653	230	7.9	60Hz	1725	2.4	D12.3	40Hz	60Hz	60Hz	16 FLT/ Alarm	9.1	0Hz	60Hz	4kHz	Ramp	Not Sel	30 sec	30 sec	30 sec
HK30WA356	ACH550-U0-06A9-4	2.4 HP 460V	HD56FE653	460	3.6	60Hz	1725	2.4	D12.3	40Hz	60Hz	60Hz	16 FLT/ Alarm	4.1	0Hz	60Hz	4kHz	Ramp	Not Sel	30 sec	30 sec	30 sec
HK30WA360	ACH550-U0-03A9-6	2.4 HP 575V	HD56FE577	575	3.8	60Hz	1725	2.4	D12.3	40Hz	60Hz	60Hz	16 FLT/ Alarm	4.4	0Hz	60Hz	4kHz	Ramp	Not Sel	30 sec	30 sec	30 sec
HK30WA352	ACH550-U0-012A-2	2.9 HP 230V	HD56FE654	230	9.2	60Hz	1725	2.9	D12.3	40Hz	60Hz	60Hz	16 FLT/ Alarm	10.6	0Hz	60Hz	4kHz	Ramp	Not Sel	30 sec	30 sec	30 sec
HK30WA356	ACH550-U0-06A9-4	2.9 HP 460V	HD56FE654	460	4.2	60Hz	1725	2.9	D12.3	40Hz	60Hz	60Hz	16 FLT/ Alarm	4.8	0Hz	60Hz	4kHz	Ramp	Not Sel	30 sec	30 sec	30 sec
HK30WA363	ACH550-U0-017A-2	3.7 HP 230V	HD60FE656	230	11.7	60Hz	1725	3.7	D12.3	40Hz	60Hz	60Hz	16 FLT/ Alarm	13.5	0Hz	60Hz	4kHz	Ramp	Not Sel	30 sec	30 sec	30 sec
HK30WA357	ACH550-U0-08A8-4	3.7 HP 460V	HD60FE656	460	5.4	60Hz	1725	3.7	D12.3	40Hz	60Hz	60Hz	16 FLT/ Alarm	6.2	0Hz	60Hz	4kHz	Ramp	Not Sel	30 sec	30 sec	30 sec
HK30WA361	ACH550-U0-06A1-6	3.7 HP 575V	HD56FE577	575	4.9	60Hz	1725	3.7	D12.3	40Hz	60Hz	60Hz	16 FLT/ Alarm	5.6	0Hz	60Hz	4kHz	Ramp	Not Sel	30 sec	30 sec	30 sec
HK30WA354	ACH550-U0-024A-2	5.3 HP 230V	HD60FK658	230	13.6	60Hz	1740	5.3	D12.3	40Hz	60Hz	60Hz	16 FLT/ Alarm	15.6	0Hz	60Hz	4kHz	Ramp	Not Sel	30 sec	30 sec	30 sec
HK30WA358	ACH550-U0-012A-4	5.3 HP 460V	HD60FK658	460	6.4	60Hz	1740	5.3	D12.3	40Hz	60Hz	60Hz	16 FLT/ Alarm	7.4	0Hz	60Hz	4kHz	Ramp	Not Sel	30 sec	30 sec	30 sec
HK30WA362	ACH550-U0-08A0-6	5.3 HP 575V	HD60FE576	575	6.0	60Hz	1725	5.3	D12.3	40Hz	60Hz	60Hz	16 FLT/ Alarm	6.9	0Hz	60Hz	4kHz	Ramp	Not Sel	30 sec	30 sec	30 sec



REMOTE VFD KEYPAD REFERENCE (CONT)

Table 5 – SRT Unit VFD Parameters — 50HC** 14

VFD Part Number	ABB Part Number	Description	Motor Part Number	Voltage (9905)	Nom Amps (9906)	Motor Nom Freq (9907)	Nom RPM (9908)	Nom HP (9909)	Const Speed Sel (1201)	Const Speed 1 (1202)	Const Speed 2 (1203)	Const Speed 3 (1204)	Relay Out 3 (1403)	Max Amps (2003)	Min Freq (2007)	Max Freq (2008)	Switch Freq (2009)	Start Fcn (2101)	Stop Fcn (2102)	Accel/Decel (2201)	Accel (2202)	Decel (2203)
HK30WA352	ACH550-U0-012A-2	2.4 HP 230V	HD56FE653	230	7.9	60Hz	1725	2.4	D1,2,3	40Hz	60Hz	60Hz	16 FLT/ Alarm	9.1	0Hz	60Hz	4kHz	Auto	Ramp	Not Sel	30 sec	30 sec
HK30WA356	ACH550-U0-06A9-2	2.4 HP 460V	HD56FE653	460	3.6	60Hz	1725	2.4	D1,2,3	40Hz	60Hz	60Hz	16 FLT/ Alarm	4.1	0Hz	60Hz	4kHz	Auto	Ramp	Not Sel	30 sec	30 sec
HK30WA380	ACH550-U0-09A9-6	2.4 HP 575V	HD56FE577	575	3.8	60Hz	1725	2.4	D1,2,3	40Hz	60Hz	60Hz	16 FLT/ Alarm	4.4	0Hz	60Hz	4kHz	Auto	Ramp	Not Sel	30 sec	30 sec
HK30WA352	ACH550-U0-012A-2	2.9 HP 230V	HD58FE654	230	9.2	60Hz	1725	2.9	D1,2,3	40Hz	60Hz	60Hz	16 FLT/ Alarm	10.6	0Hz	60Hz	4kHz	Auto	Ramp	Not Sel	30 sec	30 sec
HK30WA356	ACH550-U0-06A9-4	2.9 HP 460V	HD58FE654	460	4.2	60Hz	1725	2.9	D1,2,3	40Hz	60Hz	60Hz	16 FLT/ Alarm	4.8	0Hz	60Hz	4kHz	Auto	Ramp	Not Sel	30 sec	30 sec
HK30WA353	ACH550-U0-017A-2	3.7 HP 230V	HD60FE656	230	11.7	60Hz	1725	3.7	D1,2,3	40Hz	60Hz	60Hz	16 FLT/ Alarm	13.5	0Hz	60Hz	4kHz	Auto	Ramp	Not Sel	30 sec	30 sec
HK30WA357	ACH550-U0-08A8-4	3.7 HP 460V	HD60FE656	460	5.4	60Hz	1725	3.7	D1,2,3	40Hz	60Hz	60Hz	16 FLT/ Alarm	6.2	0Hz	60Hz	4kHz	Auto	Ramp	Not Sel	30 sec	30 sec
HK30WA361	ACH550-U0-06A1-6	3.7 HP 575V	HD58FE577	575	4.9	60Hz	1725	3.7	D1,2,3	40Hz	60Hz	60Hz	16 FLT/ Alarm	5.6	0Hz	60Hz	4kHz	Auto	Ramp	Not Sel	30 sec	30 sec
HK30WA354	ACH550-U0-024A-2	5.0 HP 230V	HD60FL657	230	17.1	60Hz	1760	5	D1,2,3	40Hz	60Hz	60Hz	16 FLT/ Alarm	19.7	0Hz	60Hz	4kHz	Auto	Ramp	Not Sel	30 sec	30 sec
HK30WA358	ACH550-U0-012A-4	5.0 HP 460V	HD60FL657	460	8.6	60Hz	1760	5	D1,2,3	40Hz	60Hz	60Hz	16 FLT/ Alarm	9.9	0Hz	60Hz	4kHz	Auto	Ramp	Not Sel	30 sec	30 sec
HK30WA382	ACH550-U0-09A0-6	5.0 HP 575V	HD60FK577	575	7.6	60Hz	1745	5	D1,2,3	40Hz	60Hz	60Hz	16 FLT/ Alarm	8.7	0Hz	60Hz	4kHz	Auto	Ramp	Not Sel	30 sec	30 sec

COOLING

⚠ WARNING

UNIT OPERATION AND SAFETY HAZARD

Failure to follow this warning could cause personal injury, death and/or equipment damage.

This system uses Puron® refrigerant which has higher pressures than R-22 and other refrigerants. No other refrigerant may be used in this system. Gauge set, hoses, and recovery system must be designed to handle Puron refrigerant. If unsure about equipment, consult the equipment manufacturer.

50HC

Condenser Coil

The condenser coil is fabricated with round tube copper hairpins and plate fins of various materials and/or coatings (see Model Number Format in the Appendix to identify the materials provided in this unit). The coil may be one-row or composite-type two-row. Composite two-row coils are two single-row coils fabricated with a single return bend end tubesheet.

Condenser Coil Maintenance and Cleaning Recommendation

Routine cleaning of coil surfaces is essential to maintain proper operation of the unit. Elimination of contamination and removal of harmful residues will greatly increase the life of the coil and extend the life of the unit. The following maintenance and cleaning procedures are recommended as part of the routine maintenance activities to extend the life of the coil.

Remove Surface Loaded Fibers

Surface loaded fibers or dirt should be removed with a vacuum cleaner. If a vacuum cleaner is not available, a soft non-metallic bristle brush may be used. In either case, the tool should be applied in the direction of the fins. Coil surfaces can be easily damaged (fin edges can be easily bent over and damage to the coating of a protected coil) if the tool is applied across the fins.

NOTE: Use of a water stream, such as a garden hose, against a surface loaded coil will drive the fibers and dirt into the coil. This will make cleaning efforts more difficult. Surface loaded fibers must be completely removed prior to using low velocity clean water rinse.

Periodic Clean Water Rinse

A periodic clean water rinse is very beneficial for coils that are applied in coastal or industrial environments. However, it is very important that the water rinse is made with a very low velocity water stream to avoid damaging the fin edges. Monthly cleaning as described below is recommended. Rinsing coils in the opposite direction of airflow is recommended.

Routine Cleaning of Coil Surfaces

Periodic cleaning with Totaline® environmentally sound coil cleaner is essential to extend the life of coils. This cleaner is available from Replacement Components Division as part number P902-0301 for a one gallon container, and part number P902-0305 for a 5 gallon container. It is recommended that all coils, including standard aluminum, pre-coated, copper/copper or E-coated coils be cleaned with the Totaline environmentally sound coil cleaner as described below. Coil cleaning should be part of the unit's regularly scheduled maintenance procedures to ensure long life of the coil. Failure to clean the coils may result in reduced durability in the environment.

Avoid use of:

- coil brighteners
- acid cleaning prior to painting
- high pressure washers
- poor quality water for cleaning

Totaline environmentally sound coil cleaner is nonflammable, hypo allergenic, non bacterial, and a USDA accepted biodegradable agent that will not harm the coil or surrounding components such as electrical wiring, painted metal surfaces, or insulation. Use of non-recommended coil cleaners is strongly discouraged since coil and unit durability could be affected.

One-Row Coil

Wash coil with commercial coil cleaner. It is not necessary to remove top panel.

Two-Row Coils

Clean coil as follows:

1. Turn off unit power, tag disconnect.
2. Remove top panel screws on condenser end of unit.
3. Remove condenser coil corner post. See Fig. 14. To hold top panel open, place coil corner post between top panel and center post. See Fig. 15.

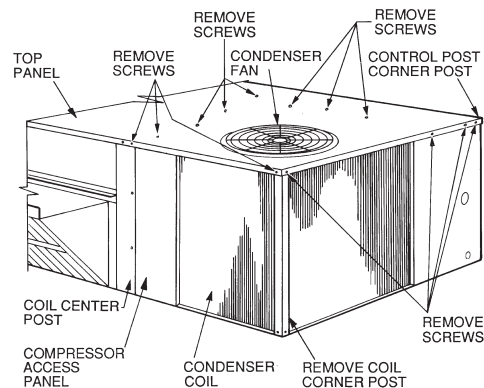
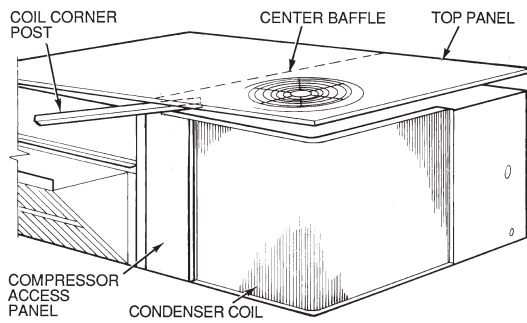

Fig. 14 - Cleaning Condenser Coil

C08205



C08206

Fig. 15 - Propping Up Top Panel

4. Remove screws securing coil to compressor plate and compressor access panel.
5. Remove fastener holding coil sections together at return end of condenser coil. Carefully separate the outer coil section 3 to 4 in. from the inner coil section. See Fig. 16.

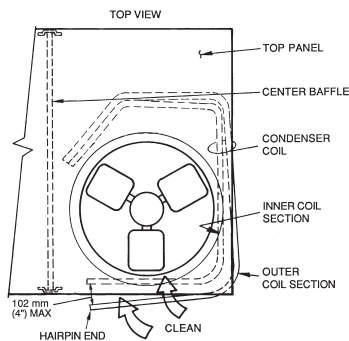

C08207

Fig. 16 - Separating Coil Sections

6. Use a water hose or other suitable equipment to flush down between the 2 coil sections to remove dirt and debris. Clean the outer surfaces with a stiff brush in the normal manner.
7. Secure inner and outer coil rows together with a field-supplied fastener.
8. Reposition the outer coil section and remove the coil corner post from between the top panel and center post. Reinstall the coil corner post and replace all screws.

Totaline Environmentally Sound Coil Cleaner Application Equipment

- 2-1/2 gallon garden sprayer
- Water rinse with low velocity spray nozzle

CAUTION

UNIT DAMAGE HAZARD

Failure to follow this caution may result in reduced unit performance or unit shutdown.

High velocity water from a pressure washer, garden hose, or compressed air should never be used to clean a coil. The force of the water or air jet will bend the fin edges and increase airside pressure drop.

CAUTION

UNIT DAMAGE HAZARD

Failure to follow this caution may result in accelerated corrosion of unit parts.

Harsh chemicals, household bleach or acid or basic cleaners should not be used to clean outdoor or indoor coils of any kind. These cleaners can be very difficult to rinse out of the coil and can accelerate corrosion at the fin/tube interface where dissimilar materials are in contact. If there is dirt below the surface of the coil, use the Totaline environmentally sound coil cleaner.

Totaline Environmentally Sound Coil Cleaner Application Instructions

1. Proper eye protection such as safety glasses is recommended during mixing and application.
2. Remove all surface loaded fibers and dirt with a vacuum cleaner as described above.
3. Thoroughly wet finned surfaces with clean water and a low velocity garden hose, being careful not to bend fins.
4. Mix Totaline environmentally sound coil cleaner in a 2-1/2 gallon garden sprayer according to the instructions included with the cleaner. The optimum solution temperature is 100°F.

NOTE: Do NOT USE water in excess of 130°F, as the enzymatic activity will be destroyed.

5. Thoroughly apply Totaline environmentally sound coil cleaner solution to all coil surfaces including finned area, tube sheets and coil headers.
6. Hold garden sprayer nozzle close to finned areas and apply cleaner with a vertical, up-and-down motion. Avoid spraying in horizontal pattern to minimize potential for fin damage.
7. Ensure cleaner thoroughly penetrates deep into finned areas.
8. Interior and exterior finned areas must be thoroughly cleaned.
9. Finned surfaces should remain wet with cleaning solution for 10 minutes.
10. Ensure surfaces are not allowed to dry before rinsing. Reapplying cleaner as needed to ensure 10-minute saturation is achieved.
11. Thoroughly rinse all surfaces with low velocity clean water using downward rinsing motion of water spray nozzle. Protect fins from damage from the spray nozzle.

Evaporator Coil

Cleaning the Evaporator Coil

1. Turn unit power off. Install lockout tag. Remove evaporator coil access panel.
2. If economizer or two-position damper is installed, remove economizer by disconnecting Molex plug and removing mounting screws.
3. Slide filters out of unit.

- Clean coil using a commercial coil cleaner or dishwasher detergent in a pressurized spray canister. Wash both sides of coil and flush with clean water. For best results, back-flush toward return-air section to remove foreign material. Flush condensate pan after completion.
- Reinstall economizer and filters.
- Reconnect wiring.
- Replace access panels.

THERMOSTATIC EXPANSION VALVE (TXV)

All 50HC's have a factory installed nonadjustable thermostatic expansion valve (TXV). The TXV will be a bi-flow, bleed port expansion valve with an external equalizer. TXVs are specifically designed to operate with Puron® or R-22 refrigerant, use only factory authorized TXVs. Do not interchange Puron and R-22 TXVs.

TXV Operation

The TXV is a metering device that is used in air conditioning and heat pump systems to adjust to the changing load conditions by maintaining a preset superheat temperature at the outlet of the evaporator coil.

The volume of refrigerant metered through the valve seat is dependent upon the following:

- Superheat temperature is sensed by cap tube sensing bulb on suction tube at outlet of evaporator coil. This temperature is converted into pressure by refrigerant in the bulb pushing downward on the diaphragm which opens the valve using the push rods.
- The suction pressure at the outlet of the evaporator coil is transferred through the external equalizer tube to the underside of the diaphragm.
- The pin is spring loaded, which exerts pressure on the underside of the diaphragm. Therefore, the bulb pressure works against the spring pressure and evaporator suction pressure to open the valve. If the load increases, the temperature increases at the bulb, which increases the pressure on the top side of the diaphragm. This opens the valve and increases the flow of refrigerant. The increased refrigerant flow causes the leaving evaporator temperature to decrease. This lowers the pressure on the diaphragm and closes the pin. The refrigerant flow is effectively stabilized to the load demand with negligible change in superheat.

Replacing TXV

- Recover refrigerant.
- Remove TXV support clamp using a 5/16-in. nut driver.
- Remove TXV using a wrench and an additional wrench on connections to prevent damage to tubing.
- Remove equalizer tube from suction line of coil. Use file or tubing cutter to cut brazed equalizer line approximately 2 inches above suction tube.
- Remove bulb from vapor tube inside cabinet.

- Install the new TXV using a wrench and an additional wrench on connections to prevent damage to tubing while attaching TXV to distributor.
- Attach the equalizer tube to the suction line. If the coil has mechanical a connection, then use a wrench and an additional wrench on connections to prevent damage. If the coil has a brazed connection, use a file or a tubing cutter to remove the mechanical flare nut from the equalizer line. Then use a new coupling to braze the equalizer line to the stub (previous equalizer line) in suction line.
- Attach TXV bulb in the same location where the original (in the sensing bulb indent) was when it was removed, using the supplied bulb clamps. See Fig. 17.

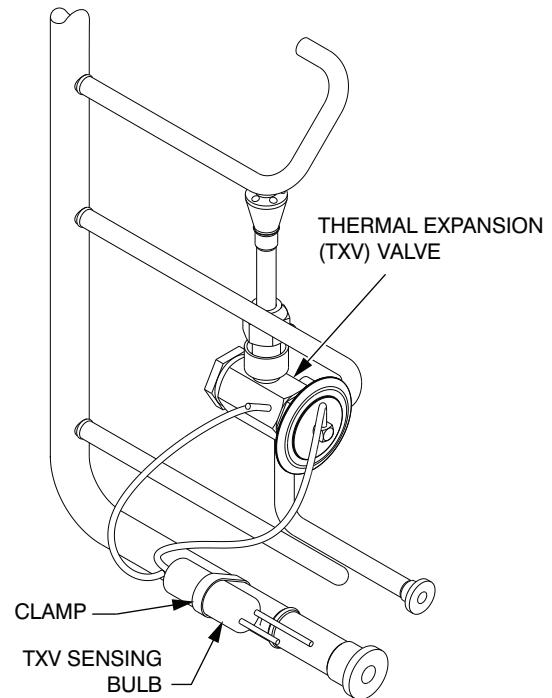

SENSING BULB INSULATION REMOVED FOR CLARITY

C10372

Fig. 17 - TXV Valve and Sensing Bulb Location

- Route equalizer tube through suction connection opening (large hole) in fitting panel and install fitting panel in place.
- Sweat the inlet of TXV marked "IN" to the liquid line. Avoid excessive heat which could damage the TXV valve. Use quenching cloth when applying heat anywhere on TXV.

Refrigerant System Pressure Access Ports

There are two access ports in the system - on the suction tube near the compressor and on the discharge tube near the compressor. These are brass fittings with black plastic caps. The hose connection fittings are standard 1/4 SAE male flare couplings.

The brass fittings are two-piece High Flow valves, with a receptacle base brazed to the tubing and an integral spring-closed check valve core screwed into the base. See Fig. 18. This check valve is permanently assembled into this core body and cannot be serviced separately; replace

the entire core body if necessary. Service tools are available from RCD that allow the replacement of the check valve core without having to recover the entire system refrigerant charge. Apply compressor refrigerant oil to the check valve core's bottom o-ring. Install the fitting body with 96 ± 10 in-lbs (10.85 ± 1.1 Nm) of torque; do not overtighten.

PURON® (R-410A) REFRIGERANT

This unit is designed for use with Puron (R-410A) refrigerant. Do not use any other refrigerant in this system. Puron (R-410A) refrigerant is provided in pink (rose) colored cylinders.

Puron (R-410A) refrigerant is provided in pink (rose) colored cylinders. These cylinders are available with and without dip tubes; cylinders with dip tubes will have a label indicating this feature. For a cylinder with a dip tube, place the cylinder in the upright position (access valve at the top) when removing liquid refrigerant for charging. For a cylinder without a dip tube, invert the cylinder (access valve on the bottom) when removing liquid refrigerant.

Because Puron (R-410A) refrigerant is a blend, it is strongly recommended that refrigerant always be removed from the cylinder as a liquid. Admit liquid refrigerant into the system in the discharge line. If adding refrigerant into the suction line, use a commercial metering/expansion device at the gauge manifold; remove liquid from the cylinder, pass it through the metering device at the gauge set and then pass it into the suction line as a vapor. Do not remove Puron (R-410A) refrigerant from the cylinder as a vapor.

Refrigerant Charge

Amount of refrigerant charge is listed on the unit's nameplate. Refer to Carrier GTAC2-5 Charging, Recovery, Recycling and Reclamation training manual and the following procedures.

Unit panels must be in place when unit is operating during the charging procedure.

No Charge

Use standard evacuating techniques. After evacuating system, weigh in the specified amount of refrigerant.

Low-Charge Cooling

Using Cooling Charging Charts, Fig. 19 through Fig. 26, vary refrigerant until the conditions of the appropriate chart are met. Note the charging charts are different from type normally used. Charts are based on charging the units to the correct sub-cooling for the various operating conditions. Accurate pressure gauge and temperature sensing device are required. Connect the pressure gauge to the service port on the liquid line. Mount the temperature sensing device on the liquid line and insulate it so that outdoor ambient temperature does not affect the reading. Indoor-air cfm must be within the normal operating range of the unit.

SIZE DESIGNATION	NOMINAL TONS REFERENCE
04	3
05	4
06	5
07	6
08	7.5
09	8.5
12	10
14	12.5

EXAMPLE:

Model 50HC*A04

Outdoor Temperature 85°F (29°C)

Suction Pressure 140 psig (965 kPa)

Suction Temperature should be 60°F (16°C)

Using Cooling Charging Charts

Take the outdoor ambient temperature and read the liquid pressure gauge. Refer to chart to determine what liquid temperature should be. If liquid temperature is low, add refrigerant. If liquid temperature is high, carefully recover some of the charge. Recheck the liquid pressure as charge is adjusted.

50HC

SEAT

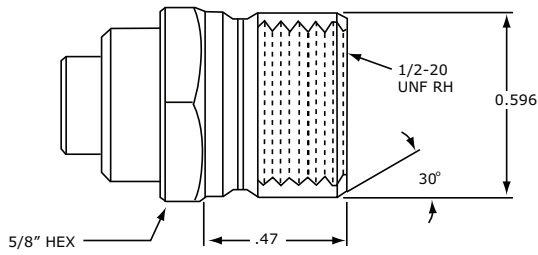

CORE

(Part No. EC39EZ067)

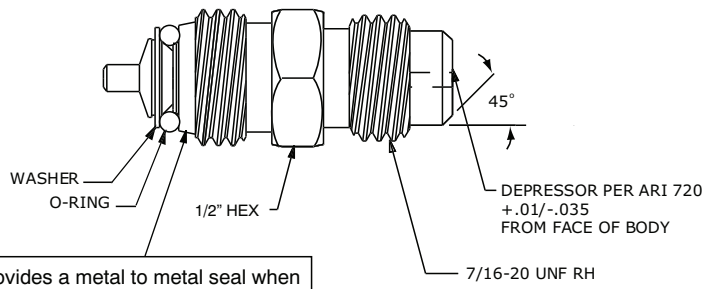

This surface provides a metal to metal seal when torqued into the seat. Appropriate handling is required to not scratch or dent the surface.

Fig. 18 - CoreMax Access Port Assembly

C08453

50HC

COOLING CHARGING CHARTS

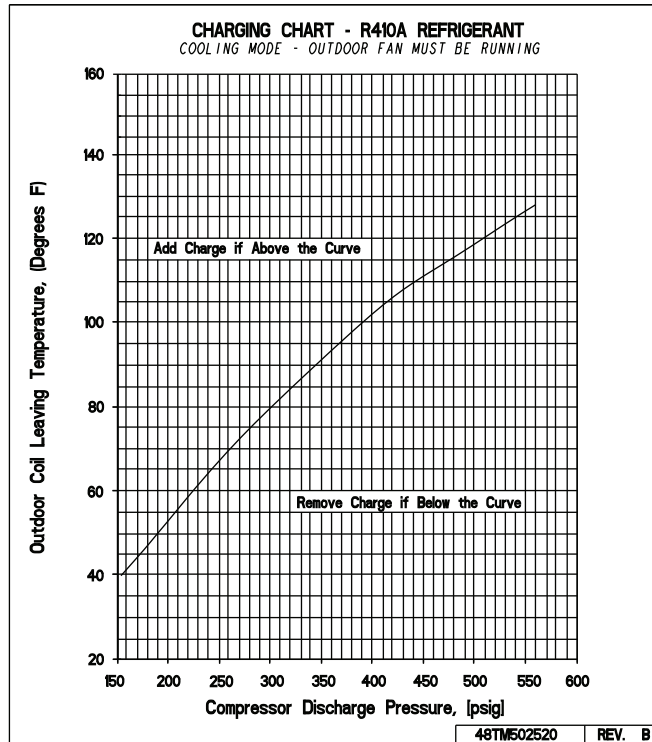

Fig. 19 - Cooling Charging Charts - 3 Ton

C14053

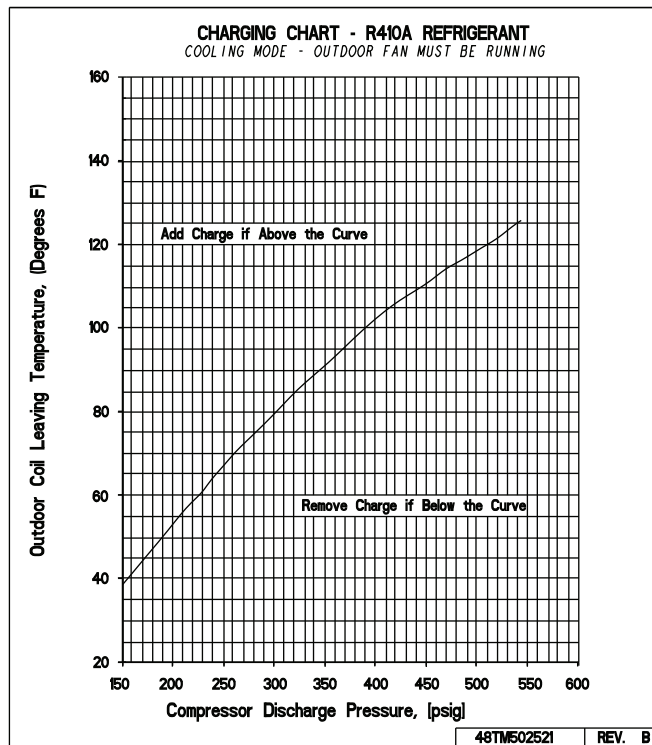

Fig. 20 - Cooling Charging Chart - 4 Ton

C14054

50HC

COOLING CHARGING CHARTS (cont.)

50HC

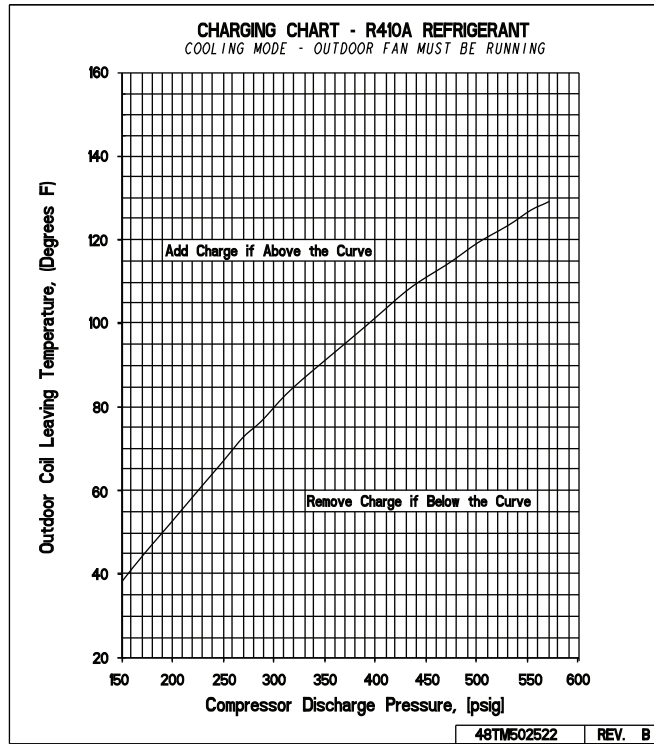

Fig. 21 - Cooling Charging Chart - 5 Ton

C14055

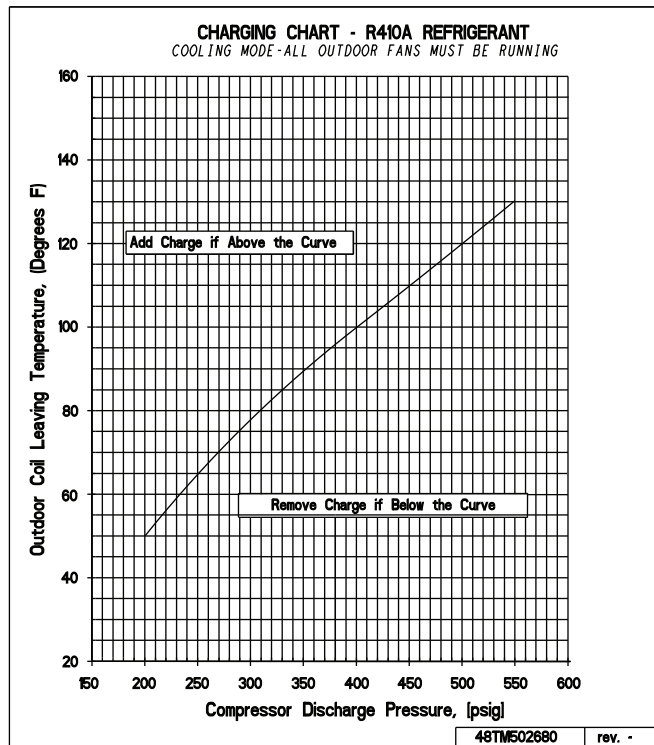

Fig. 22 - Cooling Charging Chart - 6 Ton

C14056

COOLING CHARGING CHARTS (cont.)

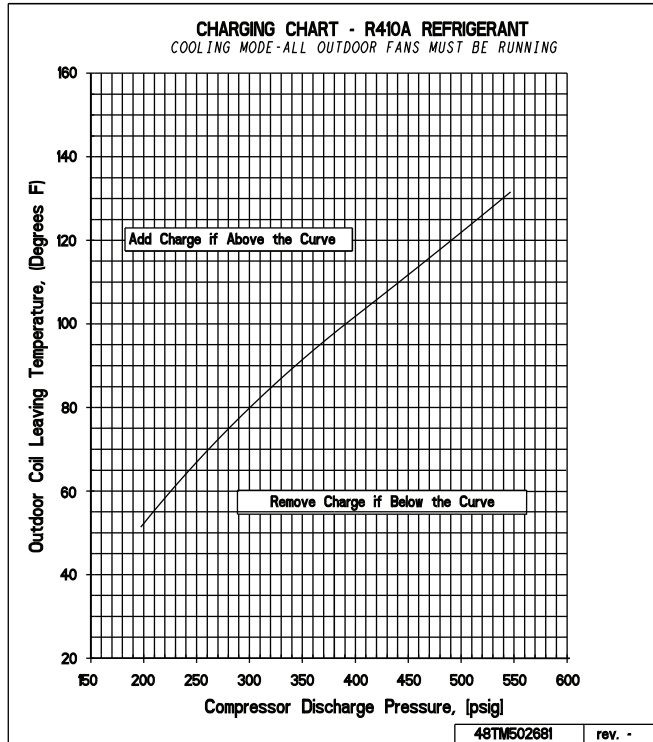

Fig. 23 - Cooling Charging Chart - 7.5 Ton

C14059

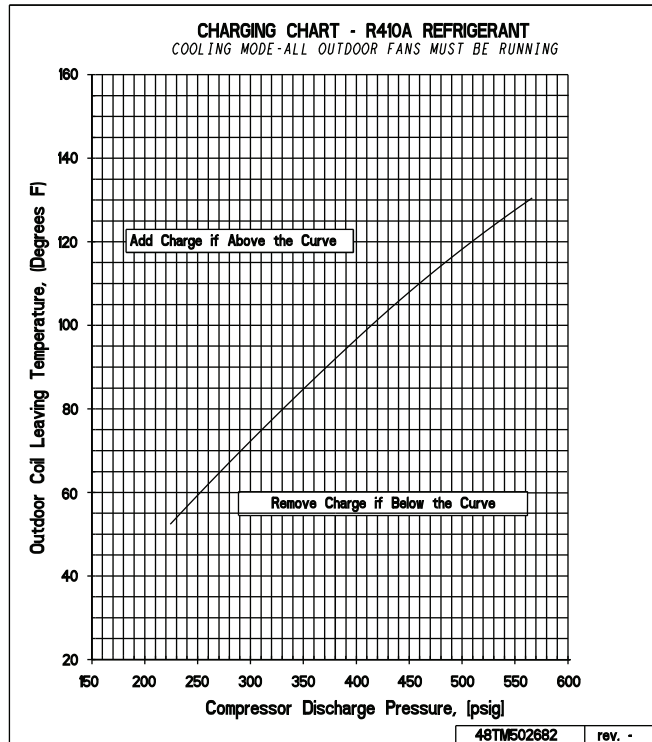

Fig. 24 - Cooling Charging Chart - 8.5 Ton

C14060

50HC

COOLING CHARGING CHARTS (cont.)

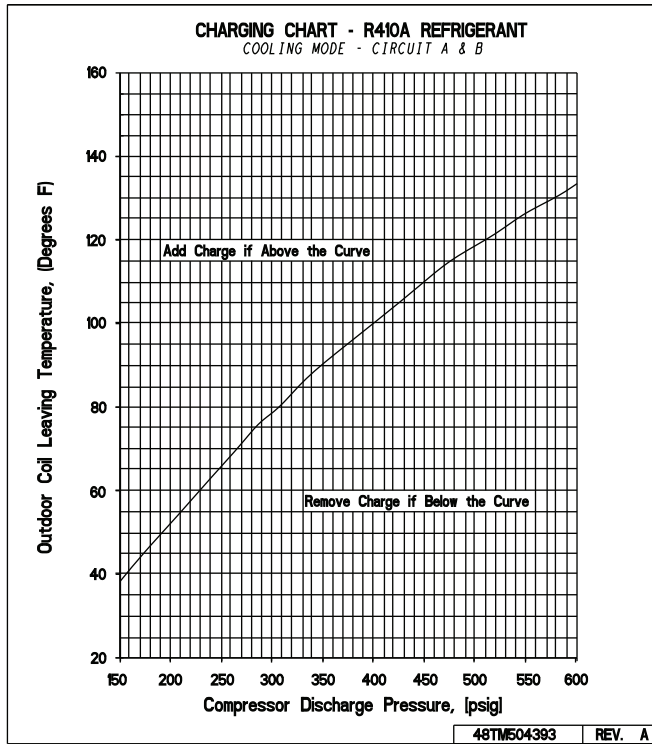

Fig. 25 - Cooling Charging Chart - 10 Ton

C14057

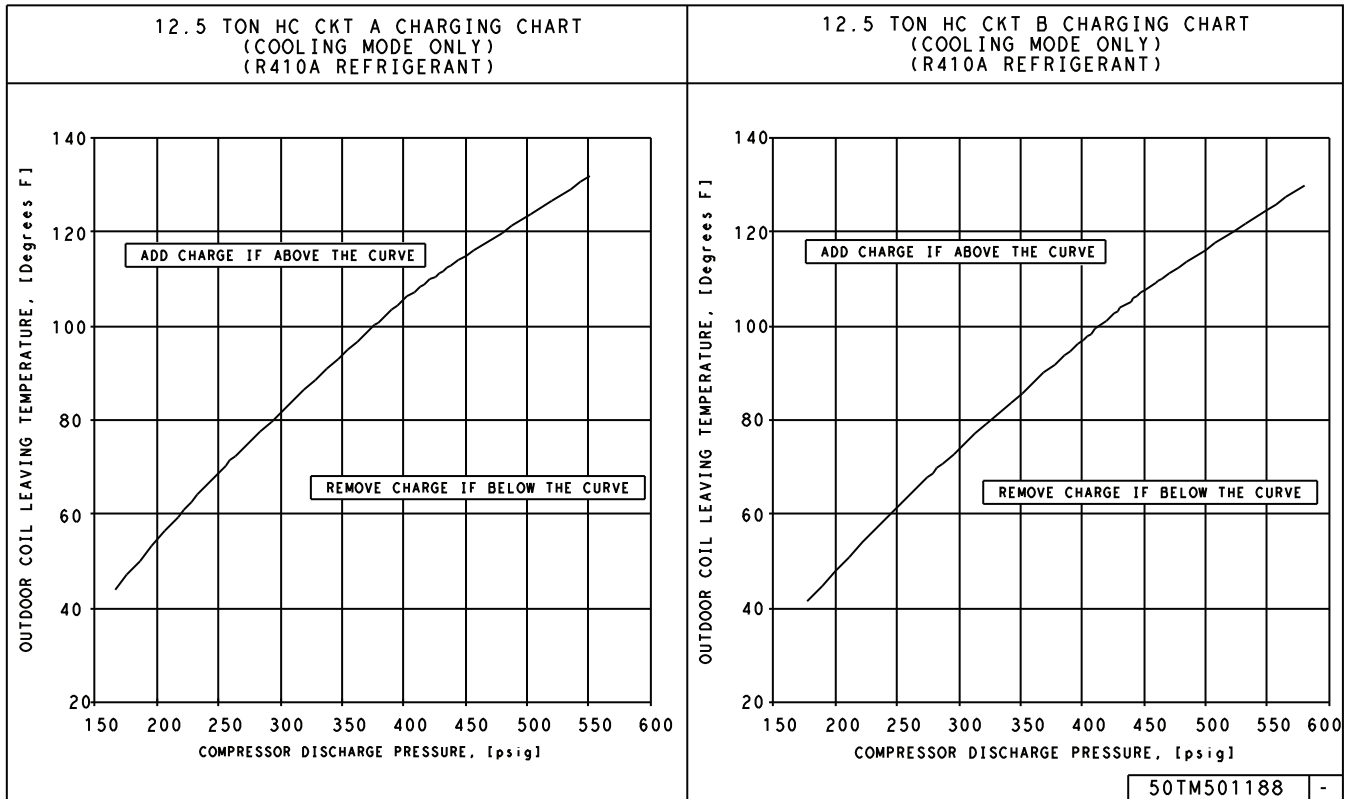

Fig. 26 - Cooling Charging Chart - 12.5 Ton - Circuit A and B

C14058

50HC

COMPRESSOR

Lubrication

The compressor is charged with the correct amount of oil at the factory.

CAUTION

UNIT DAMAGE HAZARD

Failure to follow this caution may result in damage to components.

The compressor is in a Puron® refrigerant system and uses a polyolester (POE) oil. This oil is extremely hygroscopic, meaning it absorbs water readily. POE oils can absorb 15 times as much water as other oils designed for HCFC and CFC refrigerants. Avoid exposure of the oil to the atmosphere.

⚠ WARNING

FIRE, EXPLOSION HAZARD



Failure to follow this warning could result in death, serious personal injury and/or property damage.

Never use air or gases containing oxygen for leak testing or for operating refrigerant compressors. Pressurized mixtures of air or gases containing oxygen can lead to an explosion.

⚠ WARNING

FIRE, EXPLOSION HAZARD



Failure to follow this warning could result in death, serious personal injury and/or property damage.

Never use non-certified refrigerants in this product. Non-certified refrigerants could contain contaminants that could lead to unsafe operating conditions. Use ONLY refrigerants that conform to AHRI Standard 700.

Replacing Compressor

NOTE: Only factory-trained service technicians should remove and replace compressor units.

CAUTION

INSTALLATION SITE DAMAGE

Failure to follow this caution can result in damage to equipment location site.

Puron (R-410A) refrigerant contains polyolester (POE) oil that can damage the roof membrane. Caution should be taken to prevent POE oil from spilling onto the roof surface.

The factory also recommends that the suction and discharge lines be cut with a tubing cutter instead of using a torch to remove brazed fittings.

Compressor Rotation

CAUTION

EQUIPMENT DAMAGE

Failure to follow this caution can result in equipment damage.

Scroll compressors can only compress refrigerant if rotating in the right direction. Reverse rotation for extended times can result in internal damage to the compressor. Scroll compressors are sealed units and cannot be repaired on site location.

NOTE: When the compressor is rotating in the wrong direction, the unit makes an elevated level of noise and does not provide cooling.

On 3-phase units with scroll compressors, it is important to be certain compressor is rotating in the proper direction. To determine whether or not compressor is rotating in the proper direction:

1. Connect service gauges to suction and discharge pressure fittings.
2. Energize the compressor.
3. The suction pressure should drop and the discharge pressure should rise, as is normal on any start-up.

NOTE: If the suction pressure does not drop and the discharge pressure does not rise to normal levels:

4. Note that the evaporator fan is probably also rotating in the wrong direction.
5. Turn off power to the unit.
6. Reverse any two of the three unit power leads.
7. Reapply electrical power to the compressor.
8. The suction pressure should drop and the discharge pressure should rise which is normal for scroll compressors on start-up.
9. Replace compressor if suction/discharge pressures are not within specifications for the specific compressor.

The suction and discharge pressure levels should now move to their normal start-up levels.

Filter Drier

Replace whenever refrigerant system is exposed to atmosphere. Only use factory specified liquid-line filter driers with working pressures no less than 650 psig. Do not install a suction-line filter drier in liquid line. A liquid-line filter drier designed for use with Puron refrigerant is required on every unit.

Condenser-Fan Adjustment

1. Shut off unit power supply. Install lockout tag.
2. Remove condenser-fan assembly (grille, motor, and fan).
3. Loosen fan hub setscrews.
4. Adjust fan height as shown in Fig. 27.
5. Tighten setscrews.
6. Replace condenser-fan assembly.

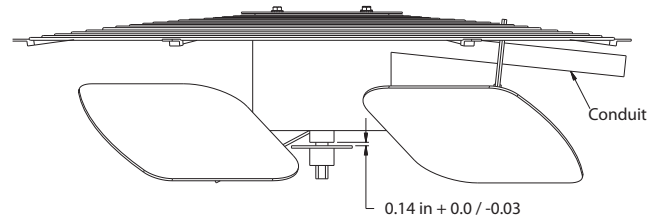

C08448

Fig. 27 - Condenser Fan Adjustment

Troubleshooting Cooling System

Refer to Table 6 for additional troubleshooting topics.

Table 6 – Cooling Troubleshooting

PROBLEM	CAUSE	REMEDY
Compressor and Outdoor Fan Will Not Start.	Power failure.	Call power company.
	Fuse blown or circuit breaker tripped.	Replace fuse or reset circuit breaker. Determine root cause.
	Defective thermostat, contactor, transformer, control relay, or capacitor.	Replace component.
	Insufficient line voltage.	Determine cause and correct.
	Incorrect or faulty wiring.	Check wiring diagram and rewire correctly.
	Thermostat setting too high.	Lower thermostat setting below room temperature.
	High pressure switch tripped.	See problem "Excessive head pressure."
	Low pressure switch tripped.	Check system for leaks. Repair as necessary.
	Freeze-up protection thermostat tripped.	See problem "Suction pressure too low."
Compressor Will Not Start But Outdoor Fan Runs.	Faulty wiring or loose connections in compressor circuit.	Check wiring and repair or replace.
	Compressor motor burned out, seized, or internal overload open.	Determine cause. Replace compressor or allow enough time for internal overload to cool and reset.
	Defective run/start capacitor, overload, start relay.	Determine cause and replace defective component.
	One leg of 3-phase power dead.	Replace fuse or reset circuit breaker. Determine cause.
Compressor Cycles (Other Than Normally Satisfying Thermostat).	Refrigerant overcharge or undercharge.	Recover refrigerant, evacuate system, and recharge to nameplate.
	Defective compressor.	Replace and determine cause.
	Insufficient line voltage.	Determine cause and correct.
	Blocked outdoor coil or dirty air filter.	Clear or clean coil. Replace filter.
	Defective run/start capacitor, overload, or start relay.	Determine cause and replace.
	Defective thermostat.	Replace thermostat.
	Faulty outdoor-fan (cooling) or indoor-fan (heating) motor or capacitor.	Replace.
	Restriction in refrigerant system.	Locate restriction and remove.
Compressor Operates Continuously.	Dirty air filter.	Replace filter.
	Unit undersized for load.	Decrease load or increase unit size.
	Thermostat set too low (cooling).	Reset thermostat.
	Low refrigerant charge.	Locate leak; repair and recharge.
	Air in system.	Recover refrigerant, replace filter dryer, evacuate system, and recharge.
	Outdoor coil dirty or restricted.	Clean coil or remove restriction.
Compressor Makes Excessive Noise.	Compressor rotating in the wrong direction.	Reverse the 3-phase power leads as described in Start-Up.
Excessive Head Pressure.	Dirty outside air or return air filter (heating).	Replace filter.
	Dirty outdoor coil (cooling).	Clean coil.
	Refrigerant overcharged.	Recover excess refrigerant.
	Air in system.	Recover refrigerant, replace filter dryer, evacuate system, and recharge.
	Condensing air restricted or air short-cycling.	Determine cause and correct.
Head Pressure Too Low.	Low refrigerant charge.	Check for leaks; repair and recharge.
	Compressor scroll plates defective.	Replace compressor.
	Restriction in liquid tube.	Remove restriction.
Excessive Suction Pressure.	High heat load.	Check for source and eliminate.
	Compressor scroll plates defective.	Replace compressor.
	Refrigerant overcharged.	Recover excess refrigerant.
Suction Pressure Too Low.	Dirty air filter (cooling).	Replace filter.
	Dirty or heavily iced outdoor coil (heating).	Clean outdoor coil. Check defrost cycle operation.
	Low refrigerant charge.	Check for leaks; repair and recharge.
	Metering device or low side restricted.	Remove source of restriction.
	Insufficient indoor airflow (cooling mode).	Increase air quantity. Check filter and replace if necessary.
	Temperature too low in conditioned area.	Reset thermostat.
	Field-installed filter drier restricted.	Replace.
	Outdoor ambient below 25°F (cooling).	Install low-ambient kit.
	Outdoor fan motor(s) not operating (heating).	Check fan motor operation.

50HC

CONVENIENCE OUTLETS

⚠ WARNING

ELECTRICAL OPERATION HAZARD

Failure to follow this warning could result in personal injury or death.

Units with convenience outlet circuits may use multiple disconnects. Check convenience outlet for power status before opening unit for service. Locate its disconnect switch, if appropriate, and open it. Tag-out this switch, if necessary.

Convenience Outlets: Two types of convenience outlets are offered on 50HC models: Non-powered and unit-powered. Both types provide a 125VAC Ground-Fault Circuit-Interrupt (GFCI) duplex receptacle rated at 15A behind a hinged waterproof access cover, located on the end panel of the unit. See Fig. 28.

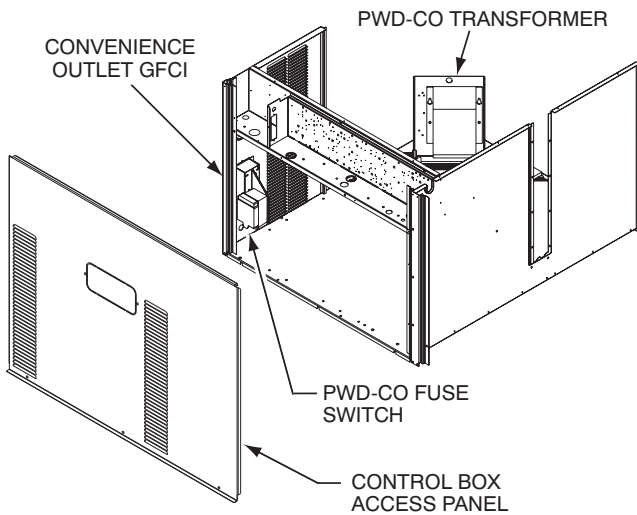

C08128

Fig. 28 - Convenience Outlet Location

Installing Weatherproof Cover: A weatherproof while-in-use cover for the factory installed convenience outlets is now required by UL standards. This cover cannot be factory-mounted due its depth. The cover must be installed at unit installation. For shipment, the convenience outlet is covered with a blank cover plate.

The weatherproof cover kit is shipped in the unit's control box. The kit includes the hinged cover, a backing plate and gasket.

NOTE: DISCONNECT ALL POWER TO UNIT AND CONVENIENCE OUTLET. Use approved lockout/tagout procedures.

1. Remove the blank cover plate at the convenience outlet; discard the blank cover.

2. Loosen the two screws at the GFCI duplex outlet, until approximately $\frac{1}{2}$ -in (13 mm) under screw heads are exposed.
3. Press the gasket over the screw heads. Slip the backing plate over the screw heads at the keyhole slots and align with the gasket; tighten the two screws until snug (do not over-tighten).
4. Mount the weatherproof cover to the backing plate as shown in Fig. 29.
5. Remove two slot fillers in the bottom of the cover to permit service tool cords to exit the cover.
6. Check cover installation for full closing and latching.

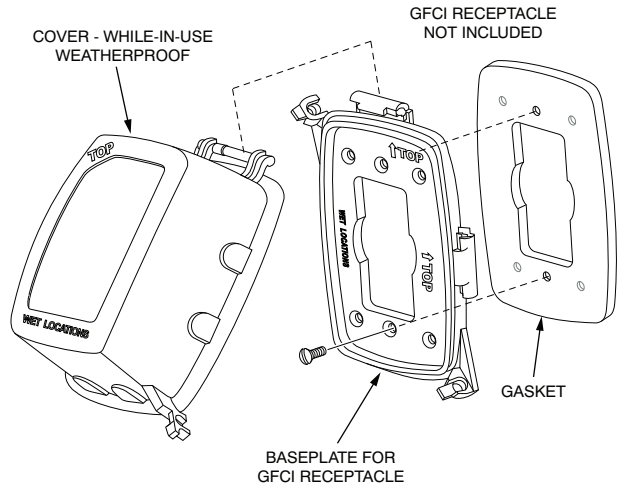

C09022

Fig. 29 - Weatherproof Cover Installation

Non-powered type: This type requires the field installation of a general-purpose 125-volt 15-A circuit powered from a source elsewhere in the building. Observe national and local codes when selecting wire size, fuse or breaker requirements and disconnect switch size and location. Route 125-v power supply conductors into the bottom of the utility box containing the duplex receptacle.

Unit-powered type: A unit-mounted transformer is factory-installed to step-down the main power supply voltage to the unit to 115-v at the duplex receptacle. This option also includes a manual switch with fuse, located in a utility box and mounted on a bracket behind the convenience outlet; access is through the unit's control box access panel. See Fig. 28.

The primary leads to the convenience outlet transformer are not factory-connected. Selection of primary power source is a customer-option. If local codes permit, the transformer primary leads can be connected at the line-side terminals on a unit-mounted non-fused disconnect or Heating, Air Conditioning and Refrigeration (HACR) breaker switch; this will provide service power to the unit when the unit disconnect switch or HACR switch is open. Other connection methods will result in the convenience outlet circuit being de-energized when the unit disconnect or HACR switch is open. See Fig. 30.

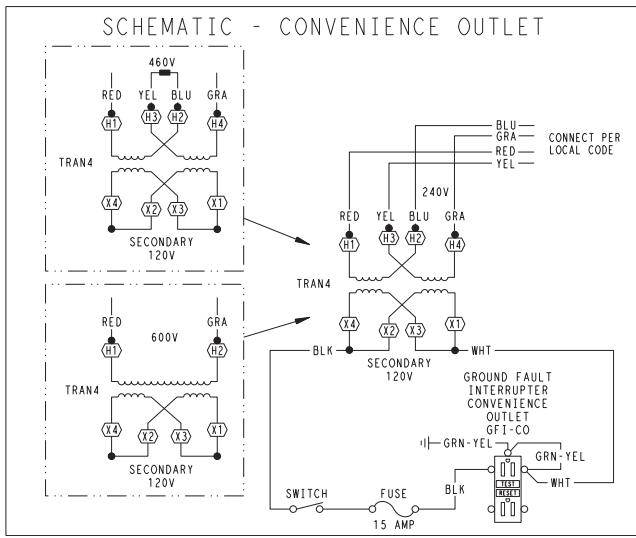

Fig. 30 - Powered Convenience Outlet Wiring

UNIT VOLTAGE	CONNECT AS	PRIMARY CONNECTIONS	TRANSFORMER TERMINALS
208, 230	240	L1: RED + YEL L2: BLU + GRA	H1 + H3 H2 + H4
460	480	L1: RED Splice BLU + YEL L2: GRA	H1 H2 + H3 H4
575	600	L1: RED L2: GRA	H1 H2

Duty Cycle: The unit-powered convenience outlet has a duty cycle limitation. The transformer is intended to provide power on an intermittent basis for service tools, lamps, etc; it is not intended to provide 15A loading for continuous duty loads (such as electric heaters for overnight use). Observe a 50% limit on circuit loading above 8A (i.e., limit loads exceeding 8A to 30 minutes of operation every hour).

Maintenance: Periodically test the GFCI receptacle by pressing the TEST button on the face of the receptacle. This should cause the internal circuit of the receptacle to trip and open the receptacle. Check for proper grounding wires and power line phasing if the GFCI receptacle does not trip as required. Press the RESET button to clear the tripped condition.

Fuse on powered type: The factory fuse is a Bussmann® Fusetron® T-15, non-renewable screw-in (Edison base) type plug fuse.

Using unit-mounted convenience outlets: Units with unit-mounted convenience outlet circuits will often require that two disconnects be opened to de-energize all power to the unit. Treat all units as electrically energized until the convenience outlet power is also checked and de-energization is confirmed. Observe National Electrical Code Article 210, Branch Circuits, for use of convenience outlets.

SMOKE DETECTORS

Smoke detectors are available as factory-installed options on 50HC models. Smoke detectors may be specified for Supply Air only or for Return Air without or with economizer or in combination of Supply Air and Return Air. Return Air smoke detectors are arranged for vertical return configurations only. All components necessary for operation are factory-provided and mounted. The unit is factory-configured for immediate smoke detector shutdown operation; additional wiring or modifications to unit terminal board may be necessary to complete the unit and smoke detector configuration to meet project requirements.

System

The smoke detector system consists of a four-wire controller and one or two sensors. Its primary function is to shut down the rooftop unit in order to prevent smoke from circulating throughout the building. It is not to be used as a life saving device.

Controller

The controller (see Fig. 31) includes a controller housing, a printed circuit board, and a clear plastic cover. The controller can be connected to one or two compatible duct smoke sensors. The clear plastic cover is secured to the housing with a single captive screw for easy access to the wiring terminals. The controller has three LEDs (for Power, Trouble and Alarm) and a manual test/reset button (on the cover face).

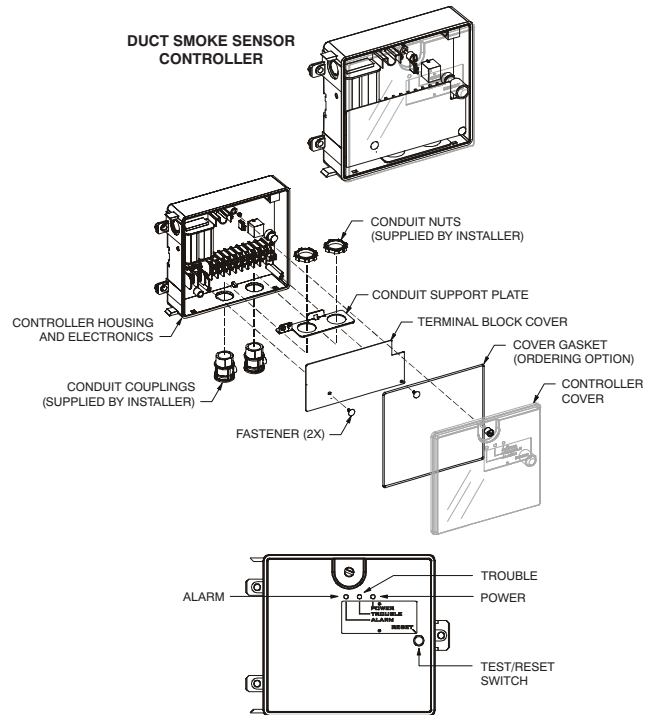

Fig. 31 - Controller Assembly

50HC

Smoke Detector Sensor

The Smoke Detector Sensor (see Fig. 32) includes a plastic housing, a printed circuit board, a clear plastic cover, a sampling tube inlet and an exhaust tube. The sampling tube (when used) and exhaust tube are attached during installation. The sampling tube varies in length depending on the size of the rooftop unit. The clear plastic cover permits visual inspections without having to disassemble the sensor. The cover attaches to the sensor housing using four captive screws and forms an airtight chamber around the sensing electronics. Each sensor includes a harness with an RJ45 terminal for connecting to the controller. Each sensor has four LEDs (for Power, Trouble, Alarm and Dirty) and a manual test/reset button (on the left-side of the housing).

Air is introduced to the duct smoke detector sensor's sensing chamber through a sampling tube that extends into the HVAC duct and is directed back into the ventilation system through a (shorter) exhaust tube.

The difference in air pressure between the two tubes pulls the sampled air through the sensing chamber. When a sufficient amount of smoke is detected in the sensing chamber, the sensor signals an alarm state and the controller automatically takes the appropriate action to shut down fans and blowers, change over air handling systems, notify the fire alarm control panel, etc.

The sensor uses a process called differential sensing to prevent gradual environmental changes from triggering false alarms. A rapid change in environmental conditions, such as smoke from a fire, causes the sensor to signal an alarm state but dust and debris accumulated over time does not.

The difference in air pressure between the two tubes pulls the sampled air through the sensing chamber. When a sufficient amount of smoke is detected in the sensing chamber, the sensor signals an alarm state and the controller automatically takes the appropriate action to shut down fans and blowers, change over air handling systems, notify the fire alarm control panel, etc.

For installations using two sensors, the duct smoke detector does not differentiate which sensor signals an alarm or trouble condition.

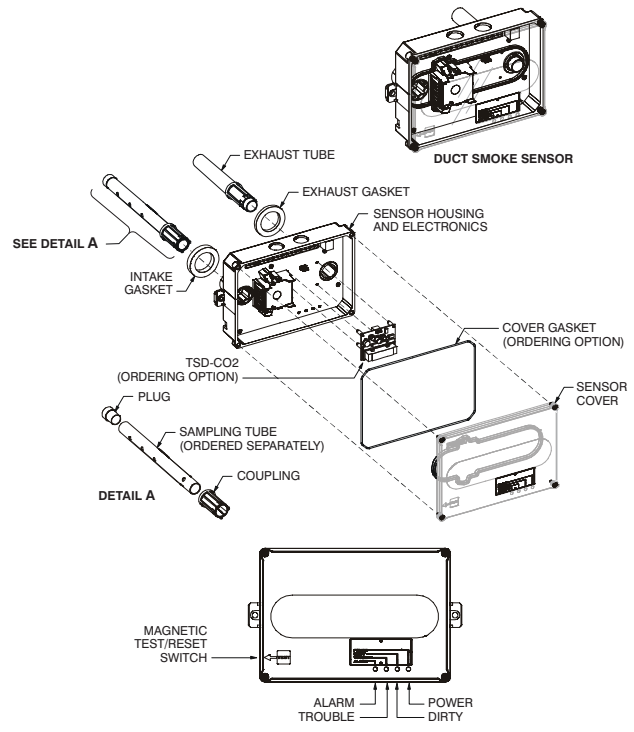

C08209

Fig. 32 - Smoke Detector Sensor

Smoke Detector Locations

Supply Air: The Supply Air Smoke Detector Sensor is located to the left of the unit's indoor (supply) fan. See Fig. 33. Access is through the fan access panel. There is no sampling tube used at this location. The sampling tube inlet extends through the side plate of the fan housing (into a high pressure area). The controller is located on a bracket to the right of the return filter, accessed through the lift-off filter panel.

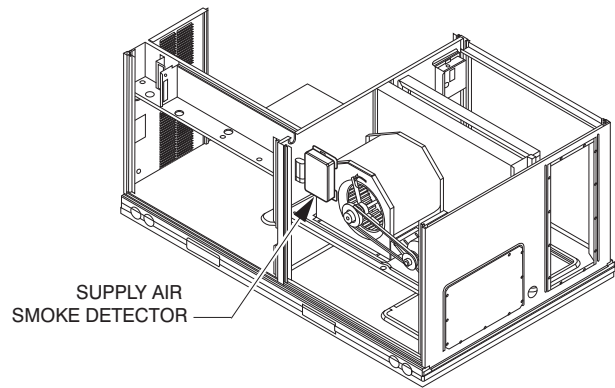

C08245

Fig. 33 - Typical Supply Air Smoke Detector Sensor Location

Return Air Smoke Detector Sensor without Economizer: The sampling tube is located across the return air opening on the unit basepan. See Fig. 34. The holes in the sampling tube face downward, into the return air stream. The sampling tube is connected through tubing to the return air sensor that is mounted on a bracket high on the partition between return filter and controller location. (This sensor is shipped in a flat-mounting location. Installation requires that this sensor be relocated to its operating location and the tubing to the sampling tube be connected. See installation steps below.)

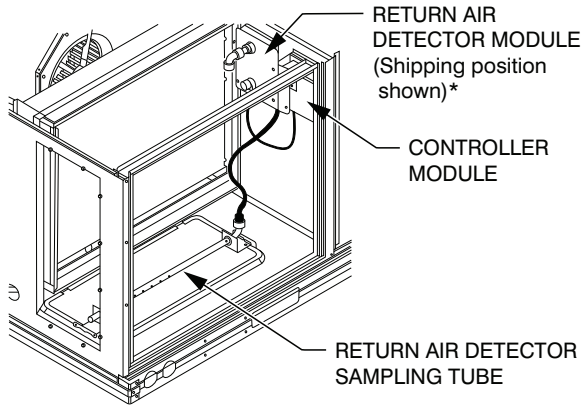

*RA detector must be moved from shipping position to operating position by installer

C07307

Fig. 34 - Typical Return Air Smoke Detector Location

Return Air Smoke Detector Sensor with Economizer: The sampling tube is inserted through the side plates of the economizer housing, placing it across the return air opening on the unit basepan. See Fig. 35. The holes in the sampling tube face downward, into the return air stream. The sampling tube is connected using tubing to the return air sensor mounted on a bracket high on the partition between return filter and controller location. The sensor is shipped in a flat-mounting location. Installation requires the sensor be relocated to its operating location and the tubing to the sampling tube be connected. See installation steps below.

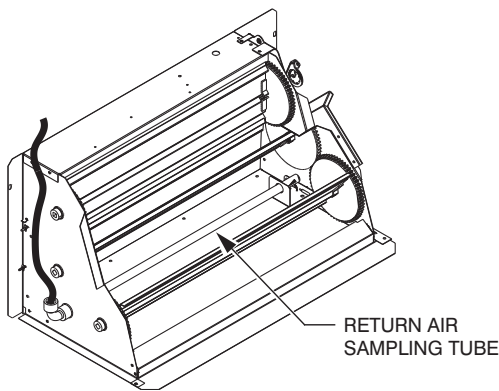

C08129

Fig. 35 - Return Air Sampling Tube Location
(View is reoriented to show opposite side for clarity.)

Completing Installation of Return Air Smoke Detector:

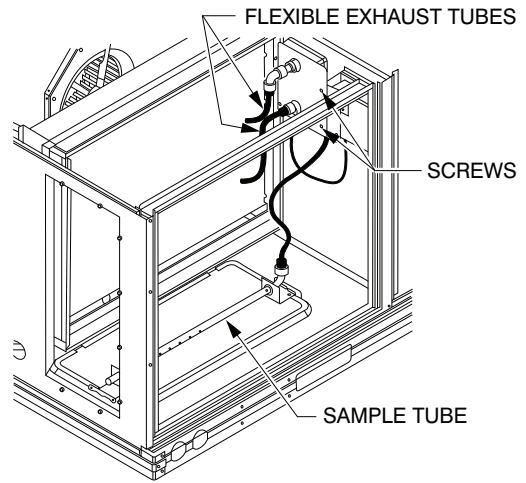

C12049

Fig. 36 - Return Air Smoke Detector Module Shipping Position

Use the following steps to complete the installation of the Return Air Smoke Detector.

1. Unscrew the two screws holding the Return Air Sensor Detector plate. See Fig. 36. Save the screws.
2. Remove the Return Air Smoke Sensor Module and its detector plate.
3. Rotate the detector plate so the sensor is facing outwards and the sampling tube connection is on the bottom. See Fig. 37.
4. Screw the sensor and detector plate into its operating position using screws from Step 1. Ensure the sampling tube connection is on the bottom and the exhaust tube is on the top. See Fig. 37.
5. Connect the flexible tube on the sampling inlet to the sampling tube on the basepan.
6. For units with an economizer, the sampling tube is integrated into the economizer housing but connecting the flexible tubing to the sampling tube is the same.

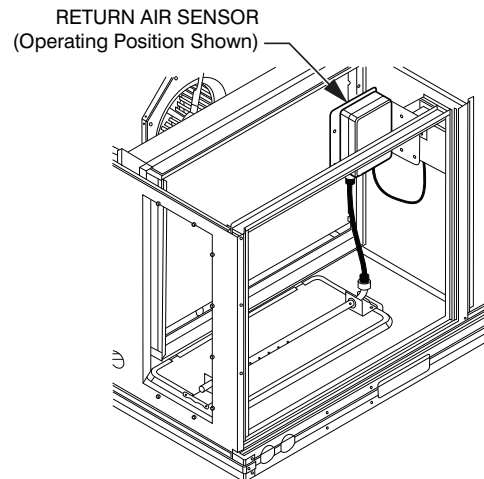

C12050

Fig. 37 - Return Air Sensor Operating Position

FIOP Smoke Detector Wiring and Response

All units: FIOP smoke detector is configured to automatically shut down all unit operations when a smoke condition is detected. See Fig. 38, Smoke Detector Wiring.

Highlight A: JMP 3 is factory-cut, transferring unit control to smoke detector.

Highlight B: Smoke detector NC contact set will open on smoke alarm condition, de-energizing the ORN conductor.

Highlight C: 24V power signal using the ORN lead is removed at the Smoke Detector input on LCTB; all unit operations cease immediately.

PremierLink™ and RTU-OPEN Controls: Unit operating functions (fan, cooling and heating) are terminated as described above. In addition:

Highlight D: On smoke alarm condition, the smoke detector NO Alarm contact will close, supplying 24-v power to GRA conductor.

Highlight E: GRA lead at Smoke Alarm input on LCTB provides 24-v signal to FIOP DDC control.

Premier-Link: This signal is conveyed to PremierLink FIOP's TB1 at terminal TB1-6 (BLU lead). This signal initiates the FSD sequence by the PremierLink control. FSD status is reported to connected CCN network.

RTU-OPEN: The 24-v signal is conveyed to RTU-OPEN - J1-10 input terminal. This signal initiates the FSD sequence by the RTU-OPEN control. FSD status is reported to connected BAS network.

Using Remote Logic: Five conductors are provided for field use (see Highlight F) for additional annunciation functions.

Additional Application Data: Refer to Catalog No. HKRKA-1XA for discussions on additional control features of these smoke detectors including multiple unit coordination. See Fig. 38.

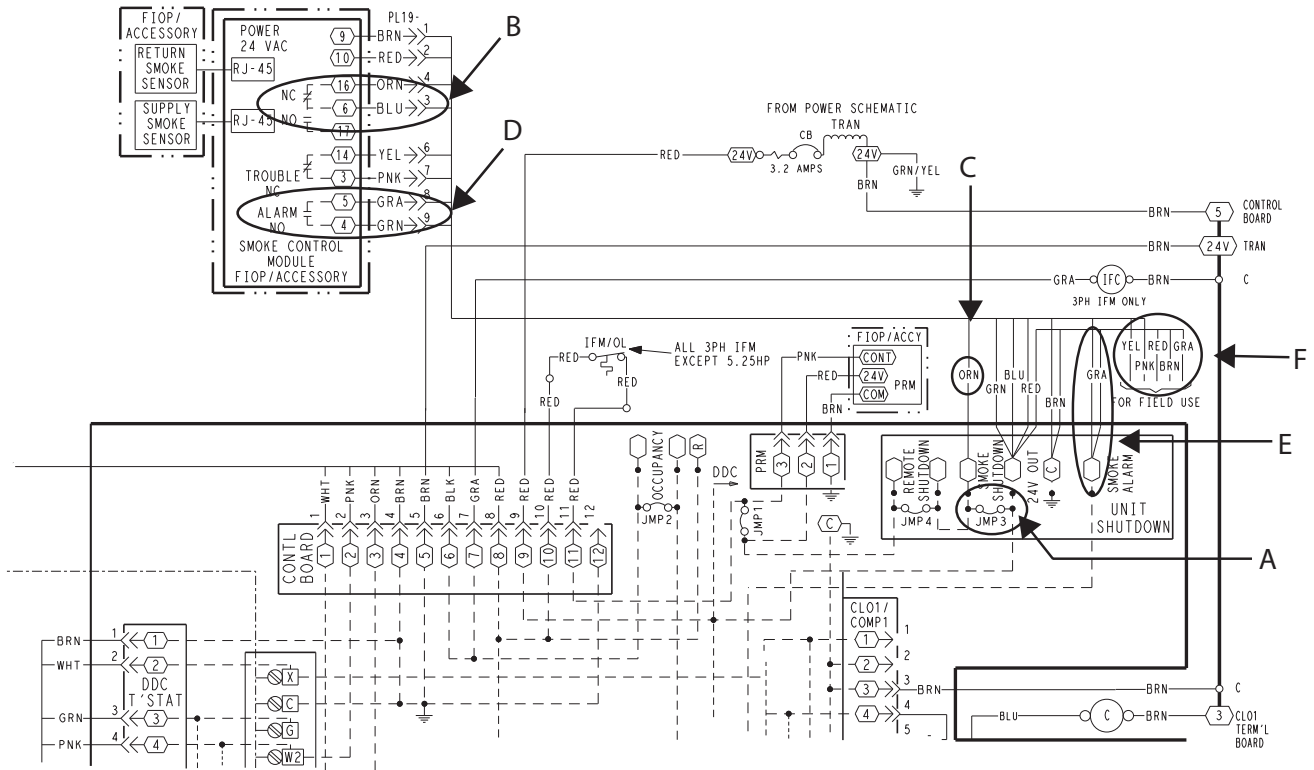

Fig. 38 - Typical Smoke Detector System Wiring

C08246

SENSOR AND CONTROLLER TESTS

Sensor Alarm Test

The sensor alarm test checks a sensor's ability to signal an alarm state. This test requires that you use a field provided SD-MAG test magnet.

NOTICE

OPERATIONAL TEST ALERT

Failure to follow this ALERT can result in an unnecessary evacuation of the facility.

This test places the duct detector into the alarm state. Unless part of the test, disconnect all auxiliary equipment from the controller before performing the test. If the duct detector is connected to a fire alarm system, notify the proper authorities before performing the test.

Sensor Alarm Test Procedure

1. Hold the test magnet where indicated on the side of the sensor housing for seven seconds.
2. Verify that the sensor's Alarm LED turns on.
3. Reset the sensor by holding the test magnet against the sensor housing for two seconds.
4. Verify that the sensor's Alarm LED turns off.

Controller Alarm Test

The controller alarm test checks the controller's ability to initiate and indicate an alarm state.

NOTICE

OPERATIONAL TEST ALERT

Failure to follow this ALERT can result in an unnecessary evacuation of the facility.

This test places the duct detector into the alarm state. Unless part of the test, disconnect all auxiliary equipment from the controller before performing the test. If the duct detector is connected to a fire alarm system, notify the proper authorities before performing the test.

Controller Alarm Test Procedure

1. Press the controller's test/reset switch for seven seconds.
2. Verify that the controller's Alarm LED turns on.

3. Reset the sensor by pressing the test/reset switch for two seconds.
4. Verify that the controller's Alarm LED turns off.

Dirty Controller Test

The dirty controller test checks the controller's ability to initiate a dirty sensor test and indicate its results.

NOTICE

OPERATIONAL TEST ALERT

Failure to follow this ALERT can result in an unnecessary evacuation of the facility.

Pressing the controller's test/reset switch for longer than seven seconds will put the duct detector into the alarm state and activate all automatic alarm responses.

Dirty Controller Test Procedure

1. Press the controller's test/reset switch for two seconds.
2. Verify that the controller's Trouble LED flashes.

Dirty Sensor Test

The dirty sensor test provides an indication of the sensor's ability to compensate for gradual environmental changes. A sensor that can no longer compensate for environmental changes is considered 100% dirty and requires cleaning or replacing. You must use a field provided SD-MAG test magnet to initiate a sensor dirty test. The sensor's Dirty LED indicates the results of the dirty test as shown in Table 7.

NOTICE

OPERATIONAL TEST ALERT

Failure to follow this ALERT can result in an unnecessary evacuation of the facility.

Holding the test magnet against the sensor housing for more than seven seconds will put the duct detector into the alarm state and activate all automatic alarm responses.

Table 7 – Dirty LED Test

FLASHES	DESCRIPTION
1	0–25% dirty. (Typical of a newly installed detector)
2	25–50% dirty
3	51–75% dirty
4	76–99% dirty

Dirty Sensor Test Procedure

1. Hold the test magnet where indicated on the side of the sensor housing for two seconds.
2. Verify that the sensor's Dirty LED flashes.

NOTICE

OPERATIONAL TEST ALERT

Failure to follow this ALERT can result in an unnecessary evacuation of the facility.

Changing the dirty sensor test operation will put the detector into the alarm state and activate all automatic alarm responses. Before changing dirty sensor test operation, disconnect all auxiliary equipment from the controller and notify the proper authorities if connected to a fire alarm system.

Changing the Dirt Sensor Test

By default, sensor dirty test results are indicated by:

- The sensor's Dirty LED flashing.
- The controller's Trouble LED flashing.
- The controller's supervision relay contacts toggle.

The operation of a sensor's dirty test can be changed so that the controller's supervision relay is not used to indicate test results. When two detectors are connected to a controller, sensor dirty test operation on both sensors must be configured to operate in the same manner.

To Configure the Dirty Sensor Test Operation

1. Hold the test magnet where indicated on the side of the sensor housing until the sensor's Alarm LED turns on and its Dirty LED flashes twice (approximately 60 seconds).
2. Reset the sensor by removing the test magnet then holding it against the sensor housing again until the sensor's Alarm LED turns off (approximately 2 seconds).

Remote Station Test

The remote station alarm test checks a test/reset station's ability to initiate and indicate an alarm state.

NOTICE

OPERATIONAL TEST ALERT

Failure to follow this ALERT can result in an unnecessary evacuation of the facility.

This test places the duct detector into the alarm state. Unless part of the test, disconnect all auxiliary equipment from the controller before performing the test. If the duct detector is connected to a fire alarm system, notify the proper authorities before performing the test.

SD-TRK4 Remote Alarm Test Procedure

1. Turn the key switch to the RESET/TEST position for seven seconds.
2. Verify that the test/reset station's Alarm LED turns on.

3. Reset the sensor by turning the key switch to the RESET/TEST position for two seconds.
4. Verify that the test/reset station's Alarm LED turns off.

Remote Test/Reset Station Dirty Sensor Test

The test/reset station dirty sensor test checks the test/reset station's ability to initiate a sensor dirty test and indicate the results. It must be wired to the controller as shown in Fig. 39 and configured to operate the controller's supervision relay. For more information, see "Changing sensor dirty test operation."

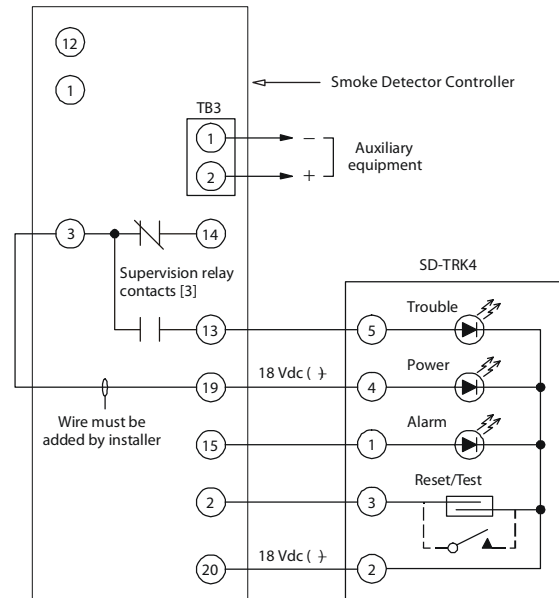

C08247

Fig. 39 - Remote Test/Reset Station Connections

NOTICE

OPERATIONAL TEST ALERT

Failure to follow this ALERT can result in an unnecessary evacuation of the facility.

If the test/reset station's key switch is left in the RESET/TEST position for longer than seven seconds, the detector will automatically go into the alarm state and activate all automatic alarm responses.

NOTICE

OPERATIONAL TEST ALERT

Failure to follow this ALERT can result in an unnecessary evacuation of the facility.

Holding the test magnet to the target area for longer than seven seconds will put the detector into the alarm state and activate all automatic alarm responses.

Dirty Sensor Test Using an SD-TRK4

1. Turn the key switch to the RESET/TEST position for two seconds.

2. Verify that the test/reset station's Trouble LED flashes.

Detector Cleaning

Cleaning the Smoke Detector

Clean the duct smoke sensor when the Dirty LED is flashing continuously or sooner if conditions warrant.

NOTICE

OPERATIONAL TEST ALERT

Failure to follow this ALERT can result in an unnecessary evacuation of the facility.

If the smoke detector is connected to a fire alarm system, first notify the proper authorities that the detector is undergoing maintenance then disable the relevant circuit to avoid generating a false alarm.

1. Disconnect power from the duct detector then remove the sensor's cover. See Fig. 40.

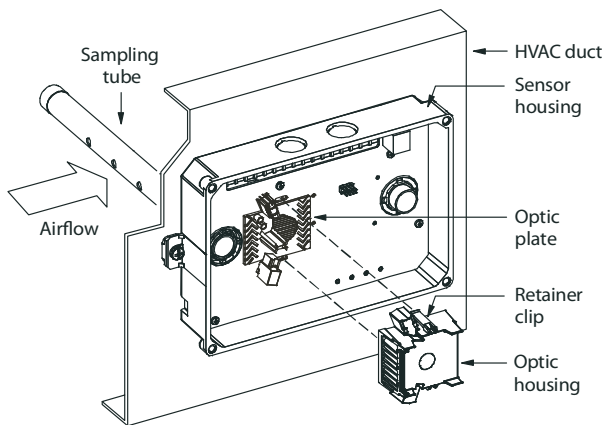

C07305

Fig. 40 - Sensor Cleaning Diagram

2. Using a vacuum cleaner, clean compressed air, or a soft bristle brush, remove loose dirt and debris from inside the sensor housing and cover. Use isopropyl alcohol and a lint-free cloth to remove dirt and other contaminants from the gasket on the sensor's cover.
3. Squeeze the retainer clips on both sides of the optic housing.
4. Lift the housing away from the printed circuit board.
5. Gently remove dirt and debris from around the optic plate and inside the optic housing.
6. Replace the optic housing and sensor cover.
7. Connect power to the duct detector then perform a sensor alarm test.

Indicators

Normal State

The smoke detector operates in the normal state in the absence of any trouble conditions and when its sensing chamber is free of smoke. In the normal state, the Power LED on both the sensor and the controller are on and all other LEDs are off.

Alarm State

The smoke detector enters the alarm state when the amount of smoke particulate in the sensor's sensing chamber exceeds the alarm threshold value. (See Table 8.)

Upon entering the alarm state:

- The sensor's Alarm LED and the controller's Alarm LED turn on.
- The contacts on the controller's two auxiliary relays switch positions.
- The contacts on the controller's alarm initiation relay close.
- The controller's remote alarm LED output is activated (turned on).
- The controller's high impedance multiple fan shutdown control line is pulled to ground Trouble state.

The SuperDuct duct smoke detector enters the trouble state under the following conditions:

- A sensor's cover is removed and 20 minutes pass before it is properly secured.
- A sensor's environmental compensation limit is reached (100% dirty).
- A wiring fault between a sensor and the controller is detected.

An internal sensor fault is detected upon entering the trouble state:

- The contacts on the controller's supervisory relay switch positions. (See Fig. 41.)
- If a sensor trouble, the sensor's Trouble LED the controller's Trouble LED turn on.
- If 100% dirty, the sensor's Dirty LED turns on and the controller's Trouble LED flashes continuously.
- If a wiring fault between a sensor and the controller, the controller's Trouble LED turns on but not the sensor's.

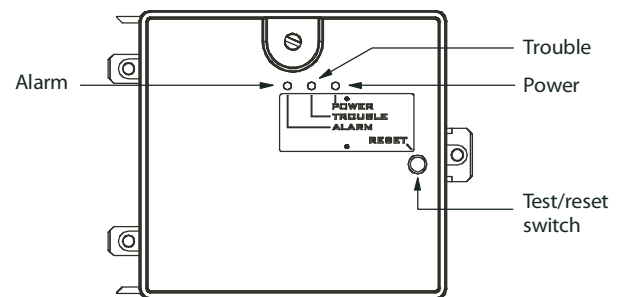

C07298

Fig. 41 - Controller Assembly

NOTE: All troubles are latched by the duct smoke detector. The trouble condition must be cleared and then the duct smoke detector must be reset in order to restore it to the normal state.

Resetting Alarm and Trouble Condition Trips:

Manual reset is required to restore smoke detector systems to Normal operation. For installations using two sensors,

the duct smoke detector does not differentiate which sensor signals an alarm or trouble condition. Check each sensor for Alarm or Trouble status (indicated by LED). Clear the condition that has generated the trip at this sensor. Then reset the sensor by pressing and holding the reset button (on the side) for 2 seconds. Verify that the sensor's Alarm and Trouble LEDs are now off. At the controller, clear its Alarm or Trouble state by pressing and holding the manual reset button (on the front cover) for 2 seconds. Verify that the controller's Alarm and Trouble LEDs are now off. Replace all panels.

Troubleshooting

Controller's Trouble LED is On

1. Check the Trouble LED on each sensor connected to the controller. If a sensor's Trouble LED is on, determine the cause and make the necessary repairs.
2. Check the wiring between the sensor and the controller. If wiring is loose or missing, repair or replace as required.

Controller's Trouble LED is Flashing

1. One or both of the sensors is 100% dirty.
2. Determine which Dirty LED is flashing then clean that sensor assembly as described in the detector cleaning section.

Sensor's Trouble LED is On

1. Check the sensor's Dirty LED. If it is flashing, the sensor is dirty and must be cleaned.
2. Check the sensor's cover. If it is loose or missing, secure the cover to the sensor housing.
3. Replace sensor assembly.

Sensor's Power LED is Off

1. Check the controller's Power LED. If it is off, determine why the controller does not have power and make the necessary repairs.
2. Check the wiring between the sensor and the controller. If wiring is loose or missing, repair or replace as required.

Controller's Power LED is Off

1. Make sure the circuit supplying power to the controller is operational. If not, make sure JP2 and JP3 are set correctly on the controller before applying power.
2. Verify that power is applied to the controller's supply input terminals. If power is not present, replace or repair wiring as required.

Remote Test/Reset Station's Trouble LED Does Not flash When Performing a Dirty Test, But the Controller's Trouble LED Does

1. Verify that the remote test/station is wired as shown in Fig. 39. Repair or replace loose or missing wiring.

2. Configure the sensor dirty test to activate the controller's supervision relay. See "Changing sensor dirty test operation."

Sensor's Trouble LED is On, But the Controller's Trouble LED is OFF

Remove JP1 on the controller.

PROTECTIVE DEVICES

Compressor Protection

Overcurrent

The compressor has internal line-break motor protection.

Over-temperature

The compressor has an internal protector to protect it against excessively high discharge gas temperatures.

High Pressure Switch

The system is provided with a high pressure switch mounted on the discharge line. The switch is stem-mounted and brazed into the discharge tube. Trip setting is 630 psig \pm 10 psig (4344 \pm 69 kPa) when hot. Reset is automatic at 505 psig (3482 kPa).

Low Pressure Switch

The system is protected against a loss of charge and low evaporator coil loading condition by a low pressure switch located on the suction line near the compressor. The switch is stem-mounted. Trip setting is 54 psig \pm 5 psig (372 \pm 34 kPa). Reset is automatic at 117 \pm 5 psig (807 \pm 34 kPa).

Evaporator Freeze Protection

The system is protected against evaporator coil frosting and low temperature conditions by a temperature switch mounted on the evaporator coil hairpin. Trip setting is 30°F \pm 5°F (-1°C \pm 3°C). Reset is automatic at 45°F (7°C).

Supply (Indoor) Fan Motor Protection

Disconnect and lockout power when servicing fan motor.

The standard supply fan motor is equipped with internal overcurrent and over-temperature protection. Protection devices reset automatically.

The High Static option supply fan motor is equipped with a pilot-circuit Thermix combination over-temperature/overcurrent protection device. This device resets automatically. Do not bypass this switch to correct trouble. Determine the cause and correct it.

Table 8 – Detector Indicators

CONTROL OR INDICATOR	DESCRIPTION
Magnetic test/reset switch	Resets the sensor when it is in the alarm or trouble state. Activates or tests the sensor when it is in the normal state.
Alarm LED	Indicates the sensor is in the alarm state.
Trouble LED	Indicates the sensor is in the trouble state.
Dirty LED	Indicates the amount of environmental compensation used by the sensor (flashing continuously = 100%)
Power LED	Indicates the sensor is energized.

Condenser Fan Motor Protection

The condenser fan motor is internally protected against over-temperature.

Relief Device

A soft solder joint at the suction service access port provides pressure relief under abnormal temperature and

pressure conditions (i.e., fire in building). Protect this joint during brazing operations near this joint.

Control Circuit, 24-V

The control circuit is protected against overcurrent conditions by a circuit breaker mounted on control transformer TRAN. Reset is manual.

50HC

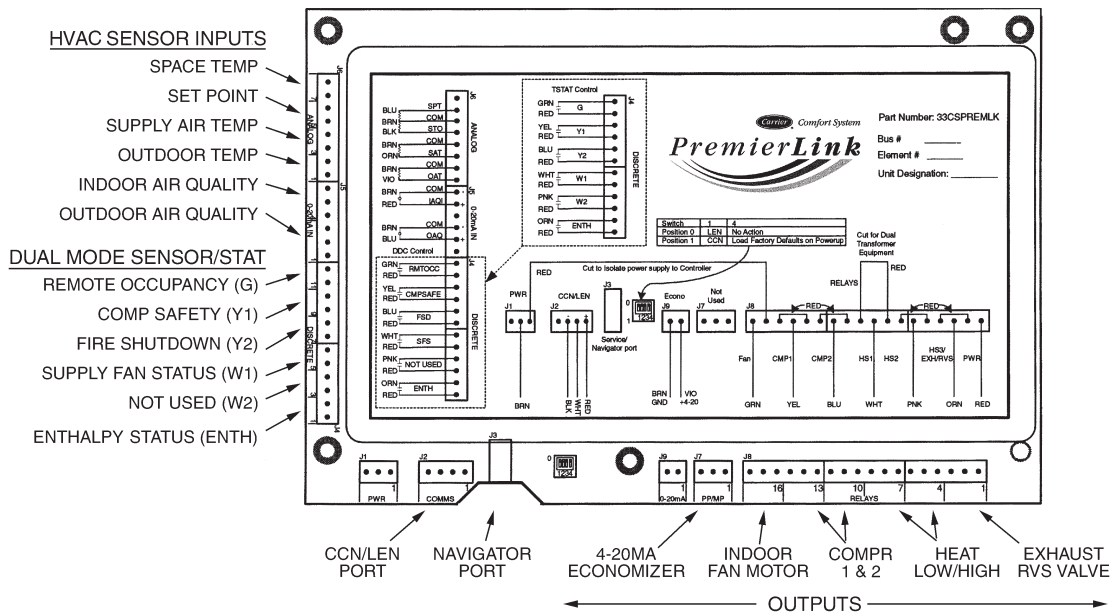

Fig. 42 - PremierLink Controller

C08199

PREMIERLINK™ CONTROL

The PremierLink controller (see Fig. 42) is compatible with Carrier Comfort Network® (CCN) devices. This control is designed to allow users the access and ability to change factory-defined settings, thus expanding the function of the standard unit control board. CCN service access tools include System Pilot™, Touch Pilot™ and Service Tool. Standard tier display tools, Navigator™ and Scrolling Marquee, are not suitable for use with the latest PremierLink controller (Version 2.x).

The PremierLink control is factory-mounted in the unit's main control box to the left of the LCTB. Factory wiring is completed through harnesses connected to the LCTB thermostat. Field connections are made at a 16-pole terminal block (TB1) located on the bottom shelf of the unit control box in front of the PremierLink controller. The factory-installed PremierLink control includes the supply-air temperature (SAT) sensor. The outdoor air

temperature (OAT) sensor is included in the FIOP/accessory EconoMiSer 2 package.

The factory-installed PremierLink Controller includes the supply-air temperature (SAT) sensor. The outdoor air temperature (OAT) sensor is included in the FIOP/accessory EconoMiSer 2 package.

Refer to Fig. 42 for PremierLink connection locations.

NOTE: Refer to *PremierLink™ Installation, Start-Up and Configuration Instructions*. Have a copy of this manual available at unit start-up.

RTU-OPEN CONTROL SYSTEM

The RTU Open controller is an integrated component of the Carrier rooftop unit. Its internal application programming provides optimum performance and energy efficiency. RTU Open enables the unit to run in 100% stand-alone control mode, Carrier's I-Vu Open network, or a Third Party Building Automation System (BAS). On-board DIP

switches allow you to select your protocol (and baud rate) of choice among the four most popular protocols in use today: BACnet, Modbus, Johnson N2 and LonWorks.

The RTU Open control is factory-mounted in the unit's main control box, to the left of the Light Commercial Terminal Board (LCTB). Factory wiring is completed through harnesses connected to the LCTB. Field connections for RTU Open sensors will be made at the Phoenix connectors on the RTU Open board. The factory-installed RTU Open control includes the supply-air temperature (SAT) sensor. The outdoor air temperature (OAT) sensor is included in the FIOP/accessory EconoMiSer2 package.

SENSORY/ACCESSORY INSTALLATION

There are a variety of sensors and accessories available for the RTU-OPEN. Some of these can be factory or field installed, while others are only field installable. The RTU-OPEN controller may also require connection to a building network system or building zoning system. All field control wiring that connects to the RTU-OPEN must be routed through the raceway built into the corner post of the unit or secured to the unit control box with electrical conduit. The unit raceway provides the UL required clearance between high and low-voltage wiring. Pass the control wires through the hole provided in the corner post,

then feed the wires through the raceway to the RTU-OPEN. Connect the wires to the removable Phoenix connectors and then reconnect the connectors to the board.

IMPORTANT: Refer to the specific sensor or accessory instructions for its proper installation and for rooftop unit installation refer to base unit installation instructions and the unit's wiring diagrams.

WARNING

ELECTRICAL SHOCK HAZARD

Failure to follow this warning could result in personal injury, death and/or equipment damage.

Disconnect and lock-out/tagout electrical power before wiring the RTU-OPEN controller.

ADDITIONAL RTU-OPEN INSTALLATION AND TROUBLESHOOTING

Additional installation, wiring and troubleshooting information for the RTU-OPEN Controller can be found in the following manuals: *“Controls, Start-up, Operation and Troubleshooting Instructions,”* and *“RTU Open Installation and Start-up Guide.”*

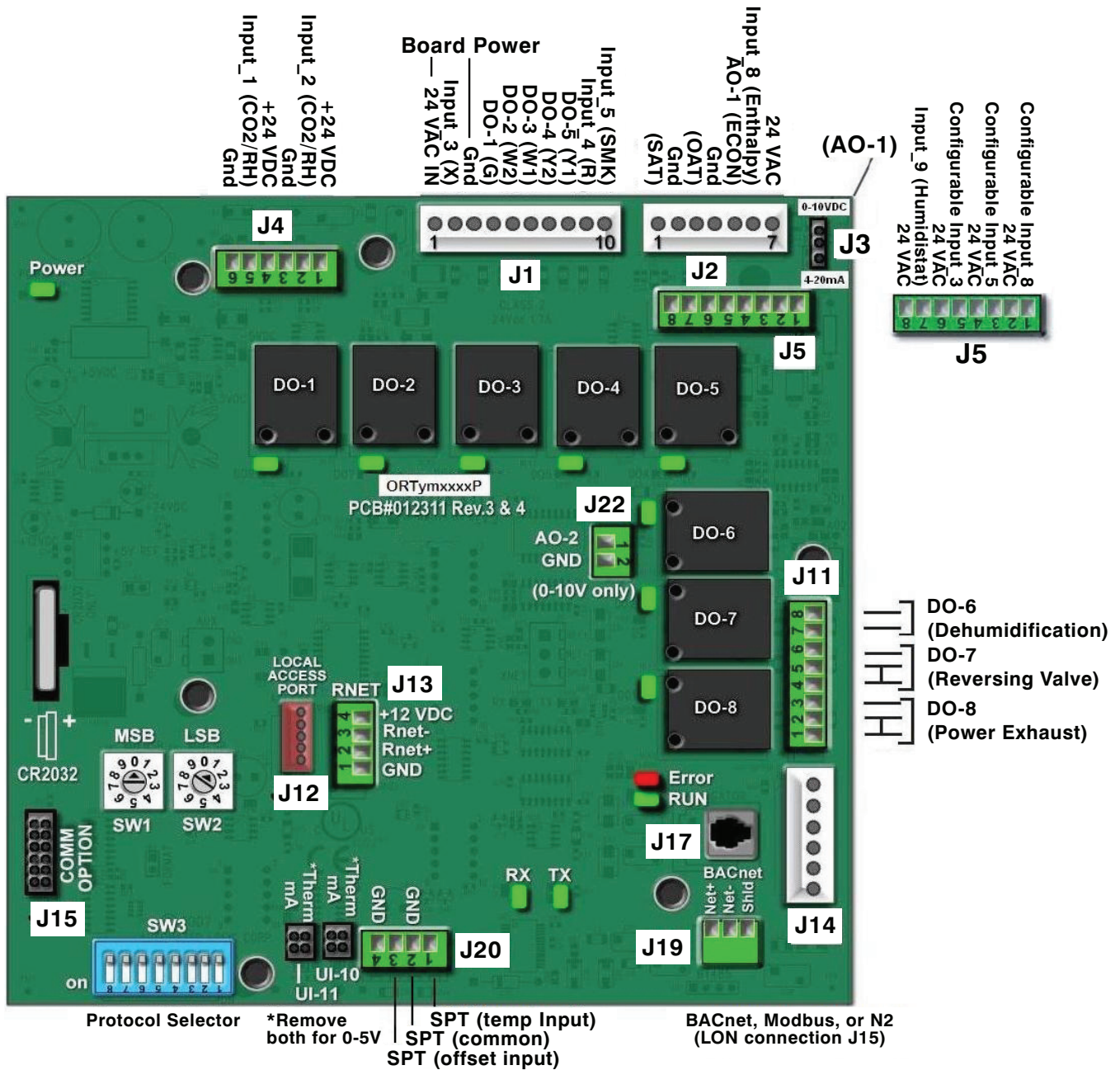

Fig. 43 - RTU-Open Control Module

C10818

ECONOMIZER SYSTEMS

The unit may be equipped with a factory-installed or accessory (field-installed) economizer system. Two types are available: with a logic control system (EconoMiSer IV) and without a control system (EconoMiSer2). See Fig. 44 and Fig. 45 for component locations on each type. See Fig. 46 and Fig. 47 for economizer section wiring diagrams.

Both economizers use direct-drive damper actuators.

IMPORTANT: Any economizer that meets the economizer requirements as laid out in California's Title 24 mandatory section 120.2 (fault detection and diagnostics) and/or prescriptive section 140.4 (life-cycle tests, damper leakage, 5 year warranty, sensor accuracy, etc), will have a label on the economizer. Any economizer without this label does not meet California's Title 24. The fire year limited parts warranty referred to in section 140.4 only applies to factory installed economizers. Please refer to your economizer on your unit.

50HC

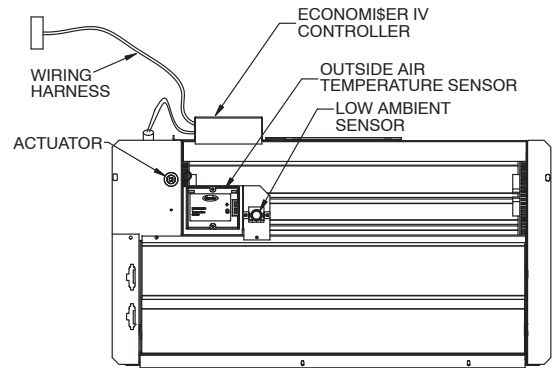

C06021

Fig. 44 - EconoMiSer IV Component Locations

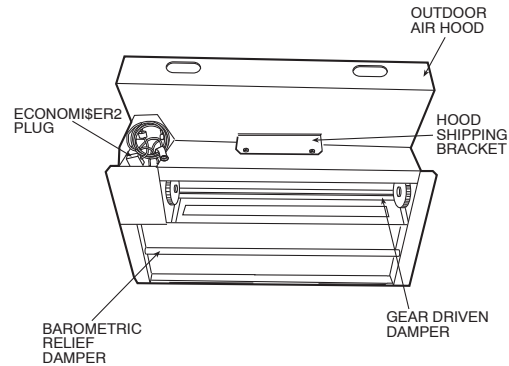

C06022

Fig. 45 - EconoMiSer2 Component Locations

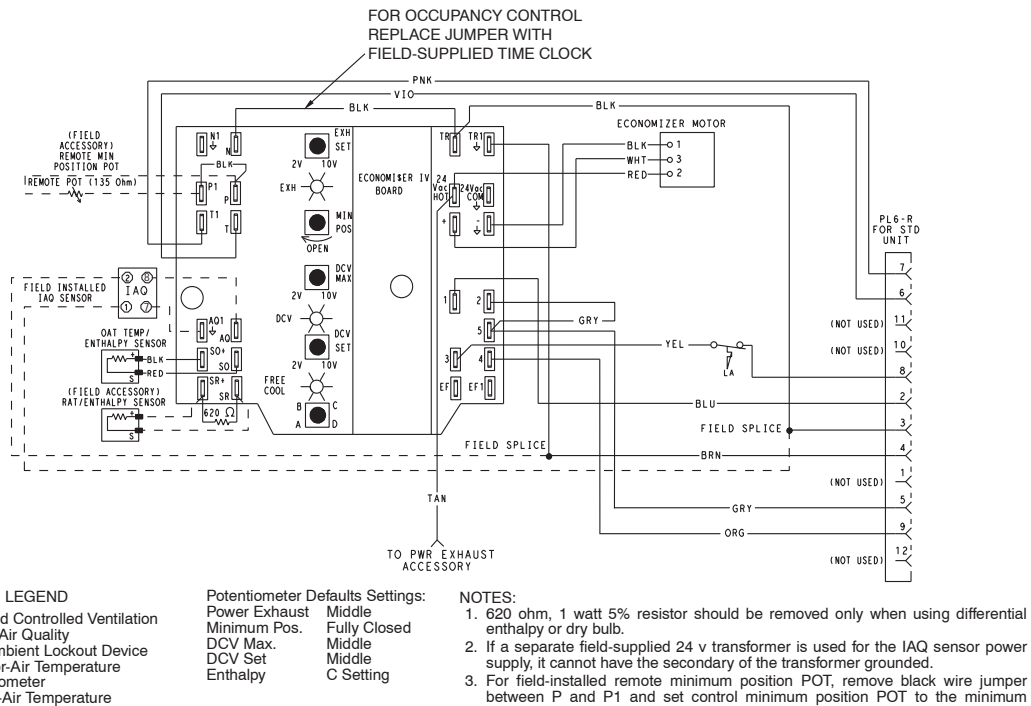
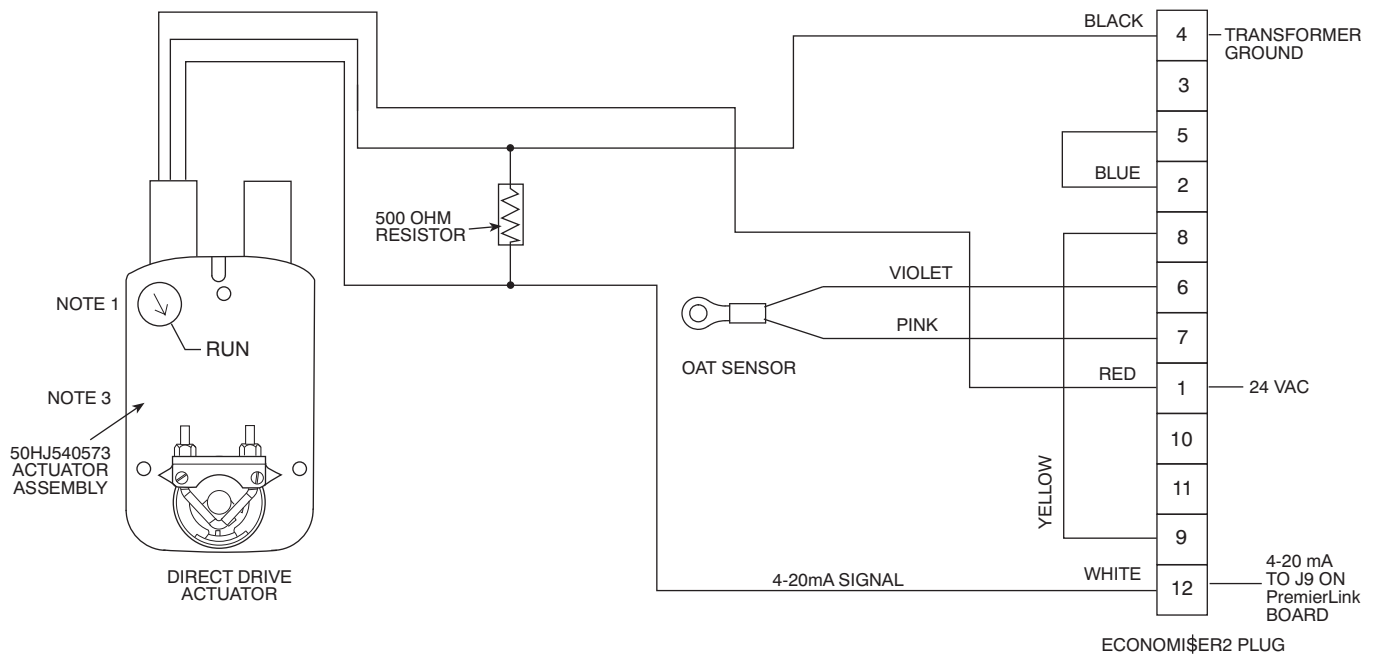

Fig. 46 - EconoMiSer IV Wiring

C06028



NOTES:

1. Switch on actuator must be in run position for economizer to operate.
2. PremierLink™ control requires that the standard 50HJ540569 outside-air sensor be replaced by either the CROASENR001A00 dry bulb sensor or HH57A077 enthalpy sensor.
3. 50HJ540573 actuator consists of the 50HJ540567 actuator and a harness with 500-ohm resistor.

C08310

Fig. 47 - EconoMi\$er2 with 4 to 20 mA Control Wiring

Table 9 – EconoMi\$er IV Input/Output Logic

INPUTS					OUTPUTS			
Demand Control Ventilation (DCV)	Enthalpy*		Y1	Y2	Compressor		N Terminal†	
	Outdoor	Return			Stage 1	Stage 2	Occupied	Unoccupied
Below set (DCV LED Off)	High (Free Cooling LED Off)	Low	On	On	On	On	Minimum position	Closed
			On	Off	On	Off		
			Off	Off	Off	Off		
	Low (Free Cooling LED On)	High	On	On	On	Off	Modulating** (between min. position and full-open)	Modulating** (between closed and full-open)
			On	Off	Off	Off		
			Off	Off	Off	Off		
Above set (DCV LED On)	High (Free Cooling LED Off)	Low	On	On	On	On	Modulating†† (between min. position and DCV maximum)	Modulating†† (between closed and DCV maximum)
			On	Off	On	Off		
			Off	Off	Off	Off		
	Low (Free Cooling LED On)	High	On	On	On	Off	Modulating***	Modulating†††
			On	Off	Off	Off		
			Off	Off	Off	Off		

* For single enthalpy control, the module compares outdoor enthalpy to the ABCD setpoint.

† Power at N terminal determines Occupied/Unoccupied setting: 24 vac (Occupied), no power (Unoccupied).

** Modulation is based on the supply-air sensor signal.

†† Modulation is based on the DCV signal.

*** Modulation is based on the greater of DCV and supply-air sensor signals, between minimum position and either maximum position (DCV) or fully open (supply-air signal).

††† Modulation is based on the greater of DCV and supply-air sensor signals, between closed and either maximum position (DCV) or fully open (supply-air signal).

50HC

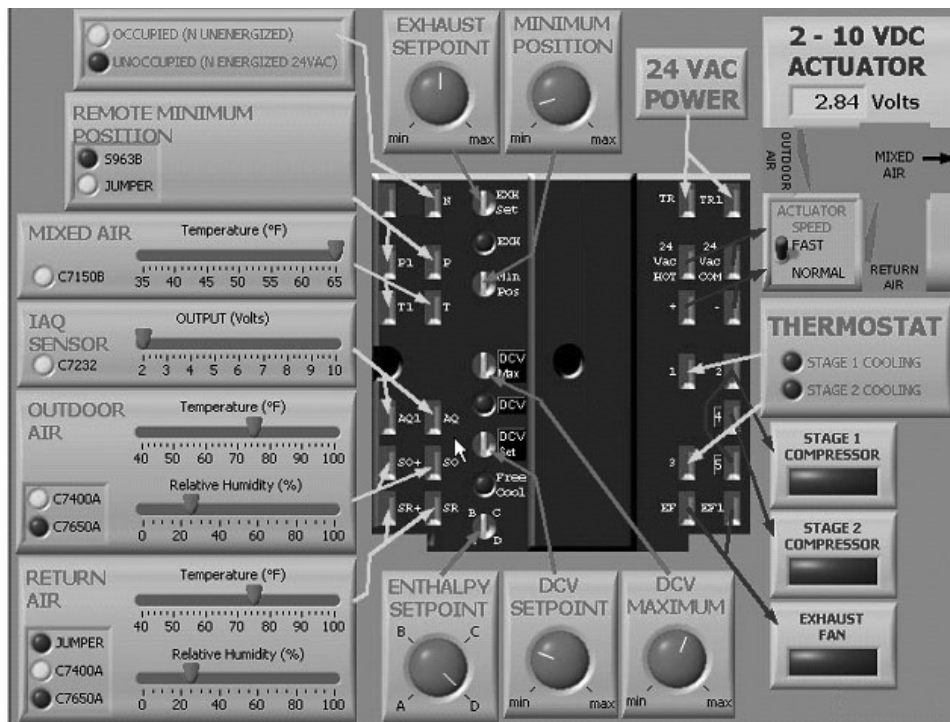

Fig. 48 - EconoMiSer IV Functional View

C06053

EconoMiSer IV Standard Sensors

Table 48 provides a summary of EconoMiSer IV. Troubleshooting instructions are enclosed. A functional view of the EconoMiSer is shown in Fig. 46. Typical settings, sensor ranges, and jumper positions are also shown. An EconoMiSer IV simulator program is available to help with EconoMiSer IV training and troubleshooting.

Outdoor Air Temperature (OAT) Sensor

The outdoor air temperature sensor (HH57AC074) is a 10 to 20 mA device used to measure the outdoor-air temperature. The outdoor-air temperature is used to determine when the EconoMiSer IV can be used for free cooling. The sensor is factory-installed on the EconoMiSer IV in the outdoor airstream. See Fig. 49. The operating range of temperature measurement is 40° to 100°F (4° to 38°C). See Fig. 51.

Supply Air Temperature (SAT) Sensor

The supply air temperature sensor is a 3 K thermistor located at the inlet of the indoor fan. See Fig. 49. This sensor is factory installed. The operating range of temperature measurement is 0° to 158°F (-18° to 70°C). See Table 49 for sensor temperature/resistance values.

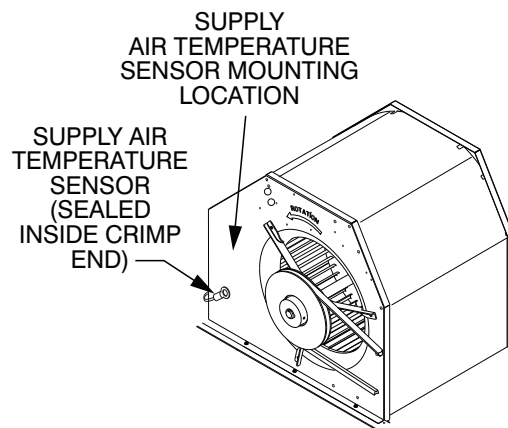

Fig. 49 - Supply Air Sensor Location

C06033

The temperature sensor looks like an eyelet terminal with wires running to it. The sensor is located in the “crimp end” and is sealed from moisture.

Outdoor Air Lockout Sensor

The EconoMiSer IV is equipped with an ambient temperature lockout switch located in the outdoor airstream which is used to lock out the compressors below a 42°F (6°C) ambient temperature. See Fig. 44.

EconoMiSer IV Control Modes

IMPORTANT: The optional EconoMiSer2 does not include a controller. The EconoMiSer2 is operated by a 4 to 20 mA signal from an existing field-supplied controller. See Fig. 45 for wiring information.

Determine the EconoMiSer IV control mode before set up of the control. Some modes of operation may require different sensors. The EconoMiSer IV is supplied from the

factory with a supply-air temperature sensor and an outdoor-air temperature sensor. This allows for operation of the EconoMi\$er IV with outdoor air dry bulb changeover control. Additional accessories can be added to allow for different types of changeover control and operation of the EconoMi\$er IV and unit.

Outdoor Dry Bulb Changeover

The standard controller is shipped from the factory configured for outdoor dry bulb changeover control. The outdoor air and supply air temperature sensors are included as standard. For this control mode, the outdoor temperature is compared to an adjustable setpoint selected on the control. If the outdoor-air temperature is above the setpoint, the EconoMi\$er IV will adjust the outside air dampers to minimum position. If the outdoor-air temperature is below the setpoint, the position of the outside air dampers will be controlled to provide free cooling using outdoor air. When in this mode, the LED next to the free cooling setpoint potentiometer will be on. The changeover temperature setpoint is controlled by the free cooling setpoint potentiometer located on the control. See Fig. 50. The scale on the potentiometer is A, B, C, and D. See Fig. 71 for the corresponding temperature changeover values.

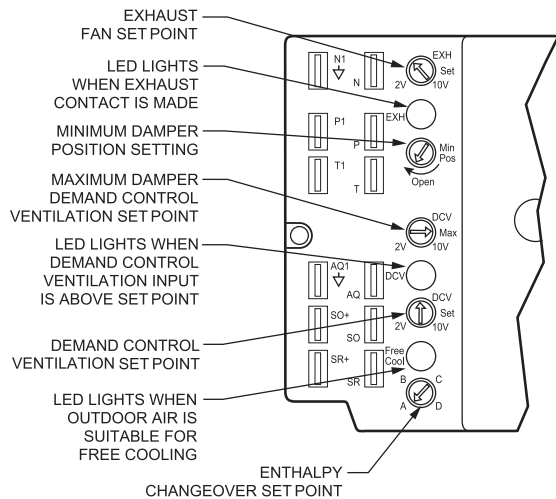

C06034

Fig. 50 - EconoMi\$er IV Controller Potentiometer and LED Locations

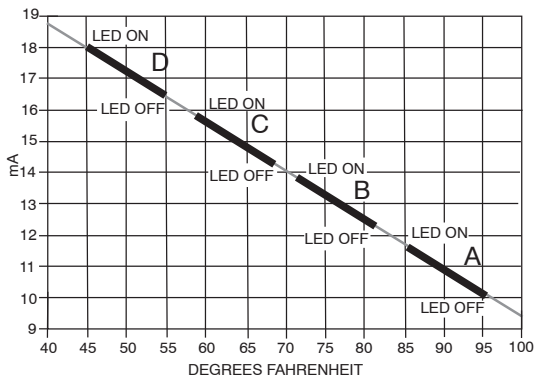

C06035

Fig. 51 - Outside Air Temperature Changeover Setpoints

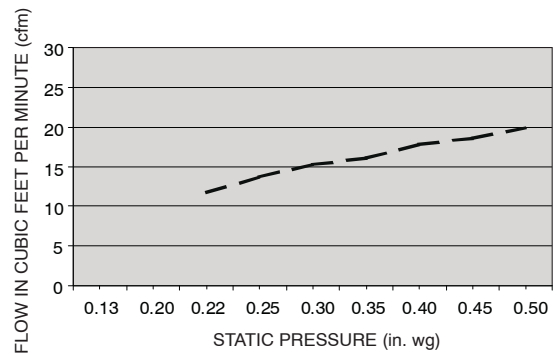

C06031

Fig. 52 - Outdoor-Air Damper Leakage

Differential Dry Bulb Control

For differential dry bulb control the standard outdoor dry bulb sensor is used in conjunction with an additional accessory dry bulb sensor (p/n: CRTEMPSN002A00). The accessory sensor must be mounted in the return airstream. See Fig. 53. Wiring is provided in the EconoMi\$er IV wiring harness.

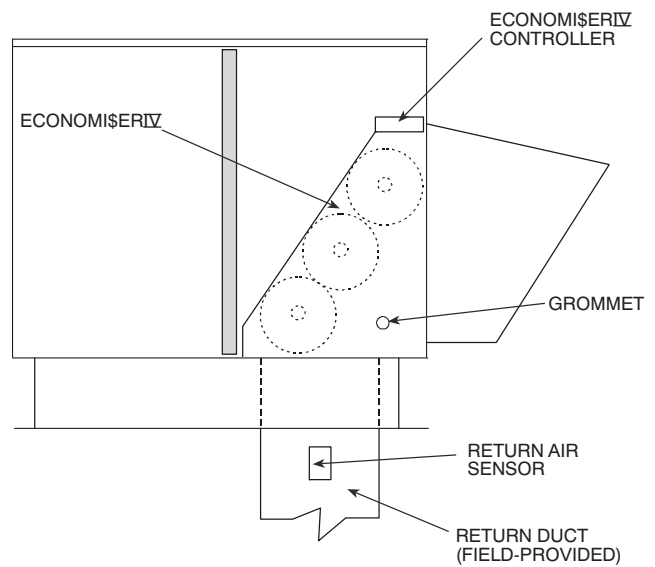

C07085

Fig. 53 - Return Air Temperature or Enthalpy Sensor Mounting Location

In this mode of operation, the outdoor-air temperature is compared to the return-air temperature and the lower temperature airstream is used for cooling. When using this mode of changeover control, turn the enthalpy setpoint potentiometer fully clockwise to the D setting. See Fig. 50.

50HC

Outdoor Enthalpy Changeover

For enthalpy control, accessory enthalpy sensor (p/n: HH57AC078) is required. Replace the standard outdoor dry bulb temperature sensor with the accessory enthalpy sensor in the same mounting location. See Fig. 73. When the outdoor air enthalpy rises above the outdoor enthalpy changeover setpoint, the outdoor-air damper moves to its minimum position. The outdoor enthalpy changeover setpoint is set with the outdoor enthalpy setpoint potentiometer on the EconoMi\$er IV controller. The setpoints are A, B, C, and D. See Fig. 74. The factory-installed 620-ohm jumper must be in place across terminals SR and SR+ on the EconoMi\$er IV controller.

50HC

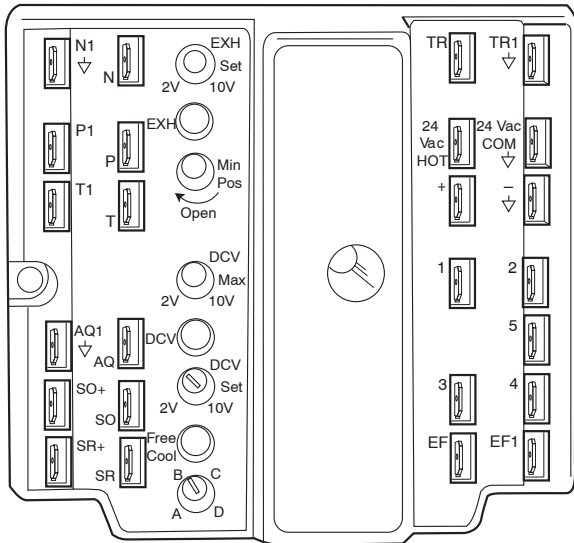

C06038

Fig. 54 - EconoMi\$er IV Control

Differential Enthalpy Control

For differential enthalpy control, the EconoMi\$er IV controller uses two enthalpy sensors (HH57AC078 and CRENTDIF004A00), one in the outside air and one in the return air duct. The EconoMi\$er IV controller compares the outdoor air enthalpy to the return air enthalpy to determine EconoMi\$er IV use. The controller selects the lower enthalpy air (return or outdoor) for cooling. For example, when the outdoor air has a lower enthalpy than the return air, the EconoMi\$er IV opens to bring in outdoor air for free cooling.

Replace the standard outside air dry bulb temperature sensor with the accessory enthalpy sensor in the same mounting location. See Fig. 45. Mount the return air enthalpy sensor in the return air duct. See Fig. 53. Wiring is provided in the EconoMi\$er IV wiring harness. See Fig. 46. The outdoor enthalpy changeover setpoint is set with the outdoor enthalpy setpoint potentiometer on the EconoMi\$er IV controller. When using this mode of changeover control, turn the enthalpy setpoint potentiometer fully clockwise to the D setting.

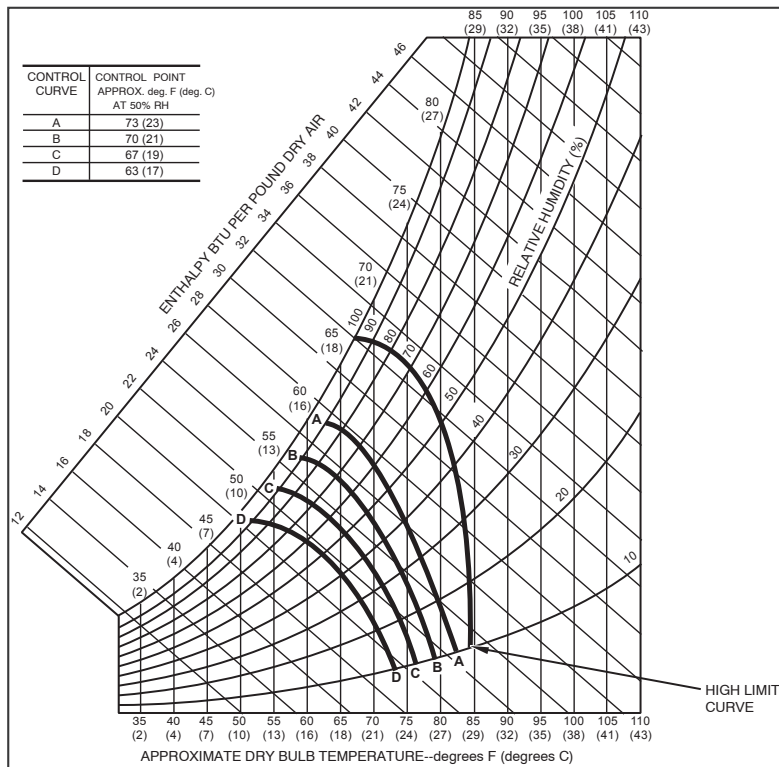

Fig. 55 - Enthalpy Changeover Setpoints

C06037

Indoor Air Quality (IAQ) Sensor Input

The IAQ input can be used for demand control ventilation control based on the level of CO₂ measured in the space or return air duct.

Mount the accessory IAQ sensor according to manufacturer specifications. The IAQ sensor should be wired to the AQ and AQ1 terminals of the controller. Adjust the DCV potentiometers to correspond to the DCV voltage output of the indoor air quality sensor at the user-determined setpoint. See Fig. 56.

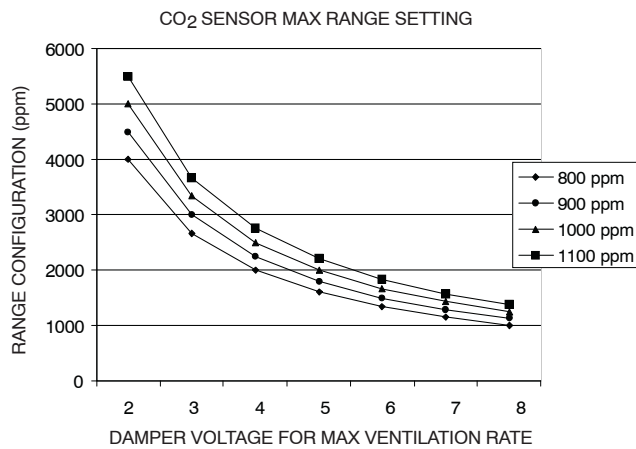

Fig. 56 - CO₂ Sensor Maximum Range Settings

If a separate field-supplied transformer is used to power the IAQ sensor, the sensor must not be grounded or the EconoMi\$er IV control board will be damaged.

When using demand ventilation, the minimum damper position represents the minimum ventilation position for VOC (volatile organic compounds) ventilation requirements. The maximum demand ventilation position is used for fully occupied ventilation.

When demand ventilation control is not being used, the minimum position potentiometer should be used to set the occupied ventilation position. The maximum demand ventilation position should be turned fully clockwise.

Exhaust Setpoint Adjustment

The exhaust setpoint will determine when the exhaust fan runs based on damper position (if accessory power exhaust is installed). The setpoint is modified with the Exhaust Fan Setpoint (EXH SET) potentiometer. See Fig. 50. The setpoint represents the damper position above which the exhaust fans will be turned on. When there is a call for exhaust, the EconoMi\$er IV controller provides a 45 ± 15 second delay before exhaust fan activation to allow the dampers to open. This delay allows the damper to reach the appropriate position to avoid unnecessary fan overload.

Minimum Position Control

There is a minimum damper position potentiometer on the EconoMi\$er IV controller. See Fig. 50. The minimum damper position maintains the minimum airflow into the building during the occupied period.

When using demand ventilation, the minimum damper position represents the minimum ventilation position for Volatile Organic Compound (VOC) ventilation

requirements. The maximum demand ventilation position is used for fully occupied ventilation.

When demand ventilation control is not being used, the minimum position potentiometer should be used to set the occupied ventilation position. The maximum demand ventilation position should be turned fully clockwise.

Adjust the minimum position potentiometer to allow the minimum amount of outdoor air, as required by local codes, to enter the building. Make minimum position adjustments with at least 10°F temperature difference between the outdoor and return-air temperatures.

To determine the minimum position setting, perform the following procedure:

1. Calculate the appropriate mixed air temperature using the following formula:

$$(T_O \times \frac{OA}{100}) + (T_R \times \frac{RA}{100}) = T_M$$

T_O = Outdoor-Air Temperature

OA = Percent of Outdoor Air

T_R = Return-Air Temperature

RA = Percent of Return Air

T_M = Mixed-Air Temperature

As an example, if local codes require 10% outdoor air during occupied conditions, outdoor-air temperature is 60°F, and return-air temperature is 75°F.

$$(60 \times .10) + (75 \times .90) = 73.5^\circ\text{F}$$

2. Disconnect the supply air sensor from terminals T and T1.
3. Ensure that the factory-installed jumper is in place across terminals P and P1. If remote damper positioning is being used, make sure that the terminals are wired according to Fig. 52 and that the minimum position potentiometer is turned fully clockwise.
4. Connect 24 vac across terminals TR and TR1.
5. Carefully adjust the minimum position potentiometer until the measured mixed air temperature matches the calculated value.
6. Reconnect the supply air sensor to terminals T and T1.

Remote control of the EconoMi\$er IV damper is desirable when requiring additional temporary ventilation. If a field-supplied remote potentiometer (Honeywell p/n: S963B1128) is wired to the EconoMi\$er IV controller, the minimum position of the damper can be controlled from a remote location.

To control the minimum damper position remotely, remove the factory-installed jumper on the P and P1 terminals on the EconoMi\$er IV controller. Wire the field-supplied potentiometer to the P and P1 terminals on the EconoMi\$er IV controller. (See Fig. 55.)

Damper Movement

Damper movement from full open to full closed (or vice versa) takes 2¹/₂ minutes.

Thermostats

The EconoMi\$er IV control works with conventional thermostats that have a Y1 (cool stage 1), Y2 (cool stage 2), W1 (heat stage 1), W2 (heat stage 2), and G (fan). The EconoMi\$er IV control does not support space temperature sensors. Connections are made at the thermostat terminal connection board located in the main control box.

Occupancy Control

The factory default configuration for the EconoMi\$er IV control is occupied mode. Occupied status is provided by the black jumper from terminal TR to terminal N. When unoccupied mode is desired, install a field-supplied timeclock function in place of the jumper between TR and N. When the timeclock contacts are closed, the EconoMi\$er IV control will be in occupied mode. When the timeclock contacts are open (removing the 24V signal from terminal N), the EconoMi\$er IV will be in unoccupied mode.

Demand Control Ventilation (DCV)

When using the EconoMi\$er IV for demand controlled ventilation, there are some equipment selection criteria which should be considered. When selecting the heat capacity and cool capacity of the equipment, the maximum ventilation rate must be evaluated for design conditions. The maximum damper position must be calculated to provide the desired fresh air.

Typically the maximum ventilation rate will be about 5 to 10% more than the typical cfm required per person, using normal outside air design criteria.

A proportional anticipatory strategy should be taken with the following conditions: a zone with a large area, varied occupancy, and equipment that cannot exceed the required ventilation rate at design conditions. Exceeding the required ventilation rate means the equipment can condition air at a maximum ventilation rate that is greater than the required ventilation rate for maximum occupancy. A proportional-anticipatory strategy will cause the fresh air supplied to increase as the room CO₂ level increases even though the CO₂ setpoint has not been reached. By the time the CO₂ level reaches the setpoint, the damper will be at maximum ventilation and should maintain the setpoint.

In order to have the CO₂ sensor control the economizer damper in this manner, first determine the damper voltage output for minimum or base ventilation. Base ventilation is the ventilation required to remove contaminants during unoccupied periods. The following equation may be used to determine the percent of outside air entering the building for a given damper position. For best results there should be at least a 10 degree difference in outside and return-air temperatures.

$$\left(T_O \times \frac{OA}{100}\right) + \left(T_R \times \frac{RA}{100}\right) = T_M$$

T_O = Outdoor-Air Temperature

OA = Percent of Outdoor Air

T_R = Return-Air Temperature

RA = Percent of Return Air

T_M = Mixed-Air Temperature

Once base ventilation has been determined, set the minimum damper position potentiometer to the correct position.

The same equation can be used to determine the occupied or maximum ventilation rate to the building. For example, an output of 3.6 volts to the actuator provides a base ventilation rate of 5% and an output of 6.7 volts provides the maximum ventilation rate of 20% (or base plus 15 cfm per person). Use Fig. 56 to determine the maximum setting of the CO₂ sensor. For example, an 1100 ppm setpoint relates to a 15 cfm per person design. Use the 1100 ppm curve on Fig. 56 to find the point when the CO₂ sensor output will be 6.7 volts. Line up the point on the graph with the left side of the chart to determine that the range configuration for the CO₂ sensor should be 1800 ppm. The EconoMi\$er IV controller will output the 6.7 volts from the CO₂ sensor to the actuator when the CO₂ concentration in the space is at 1100 ppm. The DCV setpoint may be left at 2 volts since the CO₂ sensor voltage will be ignored by the EconoMi\$er IV controller until it rises above the 3.6 volt setting of the minimum position potentiometer.

Once the fully occupied damper position has been determined, set the maximum damper demand control ventilation potentiometer to this position. Do not set to the maximum position as this can result in over-ventilation to the space and potential high humidity levels.

CO₂ Sensor Configuration

The CO₂ sensor has preset standard voltage settings that can be selected anytime after the sensor is powered up. See Table 10.

Use setting 1 or 2 for Carrier equipment. See Table 10.

1. Press Clear and Mode buttons. Hold at least 5 seconds until the sensor enters the Edit mode.
2. Press Mode twice. The STDSET Menu will appear.

Table 10 – EconoMi\$er IV Sensor Usage

APPLICATION	ECONOMI\$ER IV WITH OUTDOOR AIR DRY BULB SENSOR		
	Accessories Required		
Outdoor Air Dry Bulb	None. The outdoor air dry bulb sensor is factory installed.		
Differential Dry Bulb	CRTEMPSN002A00*		
Single Enthalpy	HH57AC078		
Differential Enthalpy	HH57AC078 and CRENTDIF004A00*		
CO ₂ for DCV Control using a Wall-Mounted CO ₂ Sensor	33ZCSENCO2		
CO ₂ for DCV Control using a Duct-Mounted CO ₂ Sensor	33ZCSENCO2† and 33ZCASPCO2**	O R	CRCBDIOX005A00††

* CRENTDIF004A00 and CRTEMPSN002A00 accessories are used on many different base units. As such, these kits may contain parts that will not be needed for installation.

† 33ZCSENCO2 is an accessory CO₂ sensor.

** 33ZCASPCO2 is an accessory aspirator box required for duct-mounted applications.

†† CRCBDIOX005A00 is an accessory that contains both 33ZCSENCO2 and 33ZCASPCO2 accessories.

3. Use the Up/Down button to select the preset number. See Table 10.
4. Press Enter to lock in the selection.
5. Press Mode to exit and resume normal operation.

The custom settings of the CO₂ sensor can be changed anytime after the sensor is energized. Follow the steps below to change the non-standard settings:

1. Press Clear and Mode buttons. Hold at least 5 seconds until the sensor enters the Edit mode.
2. Press Mode twice. The STDSET Menu will appear.
3. Use the Up/Down button to toggle to the NONSTD menu and press Enter.
4. Use the Up/Down button to toggle through each of the nine variables, starting with Altitude, until the desired setting is reached.
5. Press Mode to move through the variables.
6. Press Enter to lock in the selection, then press Mode to continue to the next variable.

Dehumidification of Fresh Air with DCV (Demand Controlled Ventilation) Control

If normal rooftop heating and cooling operation is not adequate for the outdoor humidity level, an energy recovery unit and/or a dehumidification option should be considered.

EconoMi\$er IV Preparation

This procedure is used to prepare the EconoMi\$er IV for troubleshooting. No troubleshooting or testing is done by performing the following procedure.

NOTE: This procedure requires a 9-v battery, 1.2 kilo-ohm resistor, and a 5.6 kilo-ohm resistor which are not supplied with the EconoMi\$er IV.

IMPORTANT: Be sure to record the positions of all potentiometers before starting troubleshooting.

1. Disconnect power at TR and TR1. All LEDs should be off. Exhaust fan contacts should be open.
2. Disconnect device at P and P1.
3. Jumper P to P1.
4. Disconnect wires at T and T1. Place 5.6 kilo-ohm resistor across T and T1.
5. Jumper TR to 1.
6. Jumper TR to N.
7. If connected, remove sensor from terminals SO and +. Connect 1.2 kilo-ohm 4074EJM checkout resistor across terminals SO and +.
8. Put 620-ohm resistor across terminals SR and +.
9. Set minimum position, DCV setpoint, and exhaust potentiometers fully CCW (counterclockwise).
10. Set DCV maximum position potentiometer fully CW (clockwise).
11. Set enthalpy potentiometer to D.
12. Apply power (24 vac) to terminals TR and TR1.

Differential Enthalpy

To check differential enthalpy:

1. Make sure EconoMi\$er IV preparation procedure has been performed.
2. Place 620-ohm resistor across SO and +.
3. Place 1.2 kilo-ohm resistor across SR and +. The Free Cool LED should be lit.
4. Remove 620-ohm resistor across SO and +. The Free Cool LED should turn off.
5. Return EconoMi\$er IV settings and wiring to normal after completing troubleshooting.

Single Enthalpy

To check single enthalpy:

1. Make sure EconoMi\$er IV preparation procedure has been performed.
2. Set the enthalpy potentiometer to A (fully CCW). The Free Cool LED should be lit.
3. Set the enthalpy potentiometer to D (fully CW). The Free Cool LED should turn off.
4. Return EconoMi\$er IV settings and wiring to normal after completing troubleshooting.

DCV (Demand Controlled Ventilation) and Power Exhaust

To check DCV and Power Exhaust:

1. Make sure EconoMi\$er IV preparation procedure has been performed.
2. Ensure terminals AQ and AQ1 are open. The LED for both DCV and Exhaust should be off. The actuator should be fully closed.
3. Connect a 9-v battery to AQ (positive node) and AQ1 (negative node). The LED for both DCV and Exhaust should turn on. The actuator should drive to between 90 and 95% open.
4. Turn the Exhaust potentiometer CW until the Exhaust LED turns off. The LED should turn off when the potentiometer is approximately 90%. The actuator should remain in position.
5. Turn the DCV setpoint potentiometer CW until the DCV LED turns off. The DCV LED should turn off when the potentiometer is approximately 9-v. The actuator should drive fully closed.
6. Turn the DCV and Exhaust potentiometers CCW until the Exhaust LED turns on. The exhaust contacts will close 30 to 120 seconds after the Exhaust LED turns on.
7. Return EconoMi\$er IV settings and wiring to normal after completing troubleshooting.

DCV Minimum and Maximum Position

To check the DCV minimum and maximum position:

1. Make sure EconoMi\$er IV preparation procedure has been performed.
2. Connect a 9v battery to AQ (positive node) and AQ1 (negative node). The DCV LED should turn on. The actuator should drive to between 90 and 95% open.
3. Turn the DCV Maximum Position potentiometer to midpoint. The actuator should drive to between 20 and 80% open.
4. Turn the DCV Maximum Position potentiometer to fully CCW. The actuator should drive fully closed.
5. Turn the Minimum Position potentiometer to midpoint. The actuator should drive to between 20 and 80% open.
6. Turn the Minimum Position Potentiometer fully CW. The actuator should drive fully open.
7. Remove the jumper from TR and N. The actuator should drive fully closed.
8. Return EconoMi\$er IV settings and wiring to normal after completing troubleshooting.

Supply-Air Sensor Input

To check supply-air sensor input:

1. Make sure EconoMi\$er IV preparation procedure has been performed.
2. Set the Enthalpy potentiometer to A. The Free Cool LED turns on. The actuator should drive to between 20 and 80% open.
3. Remove the 5.6 kilo-ohm resistor and jumper T to T1. The actuator should drive fully open.
4. Remove the jumper across T and T1. The actuator should drive fully closed.
5. Return EconoMi\$er IV settings and wiring to normal after completing troubleshooting.

EconoMi\$er IV Troubleshooting Completion

This procedure is used to return the EconoMi\$er IV to operation. No troubleshooting or testing is done by performing the following procedure.

1. Disconnect power at TR and TR1.
2. Set enthalpy potentiometer to previous setting.
3. Set DCV maximum position potentiometer to previous setting.
4. Set minimum position, DCV setpoint, and exhaust potentiometers to previous settings.
5. Remove 620-ohm resistor from terminals SR and +.
6. Remove 1.2 kilo-ohm checkout resistor from terminals SO and +. If used, reconnect sensor from terminals SO and +.
7. Remove jumper from TR to N.
8. Remove jumper from TR to 1.
9. Remove 5.6 kilo-ohm resistor from T and T1. Reconnect wires at T and T1.
10. Remove jumper from P to P1. Reconnect device at P and P1.
11. Apply power (24 vac) to terminals TR and TR1.

PRE-START-UP/START-UP

WARNING

PERSONAL INJURY HAZARD

Failure to follow this warning could result in personal injury or death.

1. Follow recognized safety practices and wear approved Personal Protective Equipment (PPE), including safety glasses and gloves when checking or servicing refrigerant system.
2. Do not use a torch to remove any component. System contains oil and refrigerant under pressure. To remove a component, wear PPE and proceed as follows:
 - a. Shut off all electrical power to unit. Apply applicable Lock-out/Tagout procedures.
 - b. Recover refrigerant to relieve all pressure from system using both high-pressure and low pressure ports.
 - c. Do not use a torch. Cut component connection tubing with tubing cutter and remove component from unit.
 - d. Carefully un-sweat remaining tubing stubs when necessary. Oil can ignite when exposed to torch flame.
3. Do not operate compressor or provide any electric power to unit unless compressor terminal cover is in place and secured.
4. Do not remove compressor terminal cover until all electrical power is disconnected and approved Lock-out/Tagout procedures are in place.
5. Relieve all pressure from system before touching or disturbing anything inside terminal box whenever refrigerant leak is suspected around compressor terminals.
6. Never attempt to repair a soldered connection while refrigerant system is under pressure.

WARNING

ELECTRICAL OPERATION HAZARD

Failure to follow this warning result in personal injury or death.

The unit must be electrically grounded in accordance with local codes and NEC ANSI/NFPA 70 (American National Standards Institute/National fire Protection Association).

Proceed as follows to inspect and prepare the unit for initial start-up:

1. Inspect for exterior shipping and handling damage. Document any exterior or interior issues. Remove all access panels.

2. Read and follow instructions on all WARNING, CAUTION, and INFORMATION labels attached to, or shipped with, unit.
3. Make the following inspections:
 - a. Inspect for shipping and handling damages such as broken lines, loose parts, or disconnected wires, etc.
 - b. Inspect for oil at all refrigerant tubing connections and on unit base. Detecting oil generally indicates a refrigerant leak. Leak-test all refrigerant tubing connections using electronic leak detector, halide torch, or liquid-soap solution.
 - c. Inspect all field-wiring and factory-wiring connections. Be sure that connections are completed and tight. Be sure that wires are not in contact with refrigerant tubing or sharp edges.
 - d. Inspect coil fins. If damaged during shipping and handling, carefully straighten fins with a fin comb.
4. Verify the following conditions:
 - a. Make sure that condenser-fan blade are correctly positioned in fan orifice. See Condenser-Fan Adjustment section for more details.
 - b. Make sure that air filter(s) is in place.
 - c. Make sure that condensate drain trap is filled with water to ensure proper drainage.
 - d. Make sure that all tools and miscellaneous loose parts have been removed.

START-UP, GENERAL

Unit Preparation

Make sure that unit has been installed in accordance with installation instructions and applicable codes.

IMPORTANT: Follow the base unit's start-up sequence as described in the unit's installation instructions:

In addition to the base unit start-up, there are a few steps needed to properly start-up the controls. RTU-OPEN's Service Test function should be used to assist in the base unit start-up and also allows verification of output operation. Controller configuration is also part of start-up. This is especially important when field accessories have been added to the unit. The factory pre-configures options installed at the factory. There may also be additional installation steps or inspection required during the start-up process.

Additional Installation/Inspection

Inspect the field installed accessories for proper installation, making note of which ones do or do not require configuration changes. Inspect the RTU-OPEN's Alarms for initial insight to any potential issues. Refer to the following manual: "*Controls, Start-up, Operation and Troubleshooting Instructions.*" Inspect the SAT sensor for

relocation as intended during installation. Inspect special wiring as directed below.

Return-Air Filters

Ensure correct filters are installed in unit (see Appendix II - Physical Data). Do not operate unit without return-air filters.

Outdoor-Air Inlet Screens

Outdoor-air inlet screen must be in place before operating unit.

Compressor Mounting

Compressors are internally spring mounted. Do not loosen or remove compressor hold down bolts.

Internal Wiring

Check all electrical connections in unit control boxes. Tighten as required.

Refrigerant Service Ports

Each unit system has two 1/4" SAE flare (with check valves) service ports: one on the suction line, and one on the compressor discharge line. Be sure that caps on the ports are tight.

Compressor Rotation

On 3-phase units with scroll compressors, it is important to be certain compressor is rotating in the proper direction. To determine whether or not compressor is rotating in the proper direction:

1. Connect service gauges to suction and discharge pressure fittings.
2. Energize the compressor.
3. The suction pressure should drop and the discharge pressure should rise, as is normal on any start-up.

If the suction pressure does not drop and the discharge pressure does not rise to normal levels:

4. Note that the evaporator fan is probably also rotating in the wrong direction.
5. Turn off power to the unit and install lockout tag.
6. Reverse any two of the unit power leads.
7. Re-energize to the compressor. Check pressures.

The suction and discharge pressure levels should now move to their normal start-up levels.

NOTE: When the compressor is rotating in the wrong direction, the unit will make an elevated level of noise and will not provide cooling.

Cooling

Set space thermostat to OFF position. To start unit, turn on main power supply. Set system selector switch at COOL position and fan switch at AUTO. position. Adjust thermostat to a setting below room temperature. Compressor starts on closure of contactor.

Check unit charge. Refer to Refrigerant Charge section.

Reset thermostat at a position above room temperature. Compressor will shut off. Evaporator fan will shut off after a 30-second delay.

To shut off unit, set system selector switch at OFF position. Resetting thermostat at a position above room temperature shuts unit off temporarily until space temperature exceeds thermostat setting.

Ventilation (Continuous Fan)

Set fan and system selector switches at ON and OFF positions, respectively. Evaporator fan operates continuously to provide constant air circulation. When the evaporator-fan selector switch is turned to the OFF position, there is a 30-second delay before the fan turns off.

START-UP, PREMIERLINK CONTROLS

WARNING

ELECTRICAL OPERATION HAZARD

Failure to follow this warning could result in personal injury or death.

The unit must be electrically grounded in accordance with local codes and NEC ANSI/NFPA 70 (American National Standards Institute/National Fire Protection Association.)

Use the Carrier network communication software to start up and configure the PremierLink controller.

Changes can be made using the ComfortWORKS® software, ComfortVIEW™ software, Network Service Tool, System Pilot™ device, or Touch Pilot™ device. The System Pilot and Touch Pilot are portable interface devices that allow the user to change system set-up and setpoints from a zone sensor or terminal control module. During start-up, the Carrier software can also be used to verify communication with PremierLink controller.

NOTE: All set-up and setpoint configurations are factory set and field-adjustable.

For specific operating instructions, refer to the literature provided with user interface software.

NOTICE

SET-UP INSTRUCTIONS

All set-up and set point configurations are factory set and field-adjustable.

Refer to *PremierLink™ Installation, Start-Up and Configuration Instructions* for specific operating instructions for the controller. Have a copy of this manual available at unit start-up.

Perform System Check-Out

1. Check correctness and tightness of all power and communication connections.
2. At the unit, check fan and system controls for proper operation.
3. At the unit, check electrical system and connections of any optional electric reheat coil.
4. Check to be sure the area around the unit is clear of construction dirt and debris.
5. Check that final filters are installed in the unit. Dust and debris can adversely affect system operation.
6. Verify that the PremierLink controls are properly connected to the CCN bus.

START-UP, RTU-OPEN CONTROLS

NOTICE

SET-UP INSTRUCTIONS

Refer to the following manuals for additional installation, wiring and troubleshooting information for the RTU-OPEN Controller.: *“Controls, Start-up, Operation and Troubleshooting Instructions,” “RTU Open Installation and Start-up Guide”* and *“RTU-Open Integration Guide”*. Have a copy of these manuals available at unit start-up.

FASTENER TORQUE VALUES

Table 11 – Torque Values

Supply fan motor mounting	120 in-lbs (13.6 Nm) ± 12 in-lbs (1.4Nm)
Supply fan motor adjustment plate	120 in-lbs (13.6 Nm) ± 12 in-lbs (1.4Nm)
Motor pulley setscrew	72 in-lbs (8.1 Nm) ± 5 in-lbs (0.6 Nm)
Fan pulley setscrew	72 in-lbs (8.1 Nm) ± 5 in-lbs (0.6 Nm)
Blower wheel hub setscrew	72 in-lbs (8.1 Nm) ± 5 in-lbs (0.6 Nm)
Bearing locking collar setscrew	50 in-lbs (6.2 Nm) – 60 in-lbs (6.8 Nm)
Compressor mounting bolts	65 in-lbs (7.3 Nm) – 75 in-lbs (8.5Nm)
Condenser fan motor mounting bolts	20 in-lbs (2.3 Nm) ± 2 in-lbs 0.2 Nm)
Condenser fan hub setscrew	84 in-lbs (9.5 Nm) ± 12 in-lbs (1.4 Nm)

APPENDIX I. MODEL NUMBER NOMENCLATURE

1 2 3 4 5 6 7 8 9 10 11 12 13 14 15 16 17 18
 5 0 H C - D 0 8 A 3 A 5 - 0 A 0 A 0

50HC

Product Type

50 – Elect Heat Pkg. Rooftop

Model Series – WeatherMaster

HC – High Efficiency

Electric Heater Option

- – Standard (No Electric Heat)
- A – Low Electric Heat
- B – Medium Electric Heat
- C – High Electric Heat

Refrigerant System Options

- A – Single stage cooling models
- B – Single stg cooling w/Humidi–MiZer
- D – 2 stage Cooling
- E – 2 stg cooling w/Humidi–MiZer
- F – Single stg cool w/MotorMaster low amb cntl
- G – 2 stg cool w/Motormaster low amb cntl

Nominal Cooling Capacity (Tons)

- 04 – 3 ton 09 – 8.5 ton
- 05 – 4 ton 11 – 10 ton (12.0 EER)
- 06 – 5 ton 12 – 10 ton (11.7 EER)
- 07 – 6 ton 14 – 12.5 ton
- 08 – 7.5 ton

Sensor Options

- A – None
- B – RA Smoke Detector
- C – SA Smoke Detector
- D – RA + SA Smoke Detector
- E – CO₂ Sensor
- F – RA Smoke Detector + CO₂
- G – SA Smoke Detector + CO₂
- H – RA + SA Smoke Detector + CO₂

Indoor Fan Options 3, 4, 5 Ton Models Only*

- 0 – Electric (Direct) Drive X13 motor
- 2 – Medium Static Option – Belt Drive
- 3 – High Static Option – Belt Drive

Indoor Fan Options 6–12.5 Ton Models Only

- 1 – Standard Static Option – Belt Drive
- 2 – Medium Static Option – Belt Drive
- 3 – High Static Option – Belt Drive
- C – High Static Option w/Hi–Effy Motor – Belt Drive (14 size only)

Coil Options (RTPF) (Outdoor–Indoor–Hail Guard)

- A – Al/Cu – Al/Cu
- B – Pre–coat Al/Cu – Al/Cu
- C – E–coat Al/Cu – Al/Cu
- D – E–coat AL/Cu – E–coat AL/Cu
- E – Cu/Cu – Al/Cu
- F – Cu/Cu – Cu/Cu
- M – Al/Cu – Al/Cu – Louvered Hail Guard
- N – Pre–Coat Al/Cu – Al/Cu – Louvered Hail Guard
- P – E–Coat Al/Cu – Al/Cu Louvered Hail Guard
- Q – E–Coat Al/Cu – E–coat Al/Cu – Louvered Hail Guard
- R – Cu/Cu – Al/Cu – Louvered Hail Guard
- S – Cu/Cu – Cu/Cu – Louvered Hail Guard

Packaging

- 0 – Standard
- 1 – LTL

Electrical Options

- A – None
- B – HACR breaker
- C – Non–fused disconnect
- D – Thru the base connections
- F – Non–fused disconnect & thru the base
- G – 2–speed indoor fan (VFD) controller
- J – 2–spd contr (VFD) & non–fused disc.
- K – 2–spd contr (VFD) & thru the base
- M – 2–spd cont (VFD) non–fused disc. & thru the base connections

Service Options

- 0 – None
- 1 – Un–powered Convenience Outlet
- 2 – Powered Convenience Outlet
- 3 – Hinged Panels
- 4 – Hinged Panels, un–powered C.O.
- 5 – Hinged Panels, powered C.O.
- C – Foil faced insulation

Intake / Exhaust Options

- A – None
- B – Temperature Economizer w/Barometric Relief
- F – Enthalpy Economizer w/Barometric Relief
- K – 2 position Damper
- U – Temp Ultra Low Leak Economizer w/Baro Relief
- W – Enthalpy Ultra Low Leak Econo w/Baro Relief

Base Unit Controls

- 0 – Base Electromechanical Controls. Can be used with W7212 EconoMi\$er IV (Non–Fault Detection and Diagnostic)
- 1 – PremierLink Controller
- 2 – RTU Open Multi–Protocol Controller
- 6 – Electromechanical Controls. Can be used with W7220 EconoMi\$er X (Non–Fault Detection and Diagnostic)
- D – ComfortLink Controls

Design Revision

- Factory Design Revision

Voltage

- 1 – 575/3/60
- 3 – 208–230/1/60
- 5 – 208–230/3/60
- 6 – 460/3/60

Note: On single phase (–3 voltage code) models, the following are not available as a factory installed option:

- Humidi–MiZer
- Coated Coils or CU Fin Coils
- Louvered Hail Guards
- Economizer or 2 Position Damper
- Powered 115 Volt Convenience Outlet

* See Price Page details for specific Humidi–MiZer models

Not all possible options can be displayed above – see price pages or contact your Carrier Expert for more details

Fig. 57 - Model Number Nomenclature

APPENDIX II. PHYSICAL DATA

Table 12 – PHYSICAL DATA

(COOLING)

3 - 6 TONS

		50HC*04	50HC*05	50HC*06	50HC*07
Refrigeration System					
	# Circuits / # Comp. / Type	1 / 1 / Scroll	1 / 1 / Scroll	1 / 1 / Scroll	1 / 1 / Scroll
	Puron® refriger. (R-410A) charge (lbs-oz)	9 - 0	12 - 8	13 - 3	14 - 0
	Humidi-MiZer Puron refriger. (R-410A) charge (lbs-oz)	11 - 0	19 - 12	20 - 0	22 - 8
	Metering Device	TXV	TXV	TXV	TXV
	High-pressure Trip / Reset (psig)	630 / 505	630 / 505	630 / 505	630 / 505
	Low-pressure Trip / Reset (psig)	54 / 117	54 / 117	54 / 117	54 / 117
	Compressor Capacity Staging (%)	100%	100%	100%	100%
Evaporator Coil					
	Material (Tube Fin)	Cu / Al	Cu / Al	Cu / Al	Cu / Al
	Coil type	3/8-in RTPF	3/8-in RTPF	3/8-in RTPF	3/8-in RTPF
	Rows / FPI	3 / 15	3 / 15	4 / 15	3 / 15
	Total Face Area (ft ²)	5.5	7.3	7.3	8.9
	Condensate Drain Conn. Size	3/4-in	3/4-in	3/4-in	3/4-in
Humidi-MiZer Coil					
	Material (Tube Fin)	Cu / Al	Cu / Al	Cu / Al	Cu / Al
	Coil type	3/8-in RTPF	3/8-in RTPF	3/8-in RTPF	3/8-in RTPF
	Rows / FPI	1 / 17	2 / 17	2 / 17	2 / 17
	Total Face Area (ft ²)	3.9	5.2	5.2	5.2
Evaporator Fan and Motor					
Standard Static 1 phase	Motor Qty / Drive Type	1 / Direct	1 / Direct	1 / Direct	-
	Max BHP	1.0	1.0	1.0	-
	RPM Range	600-1200	600-1200	600-1200	-
	Motor Frame Size	48	48	48	-
	Fan Qty / Type	1 / Centrifugal	1 / Centrifugal	1 / Centrifugal	-
	Fan Diameter (in)	10 x 10	10 x 10	10 x 10	-
Standard Static 3 phase	Motor Qty / Drive Type	1 / Direct	1 / Direct	1 / Direct	1 / Belt
	Max BHP	1.0	1.0	1.0	1.7
	RPM Range	600-1200	600-1200	600-1200	489-747
	Motor Frame Size	48	48	48	56
	Fan Qty / Type	1 / Centrifugal	1 / Centrifugal	1 / Centrifugal	1 / Centrifugal
	Fan Diameter (in)	10 x 10	10 x 10	11 x 10	15 x 15
Standard Static 3 phase*	Motor Qty / Drive Type	1 / Belt	1 / Belt	1 / Belt	1 / Belt
	Max BHP	1.7	1.7	1.7	1.7
	RPM Range	560-854	560-854	770-1175	489-747
	Motor Frame Size	48	48	48	56
	Fan Qty / Type	1 / Centrifugal	1 / Centrifugal	1 / Centrifugal	1 / Centrifugal
	Fan Diameter (in)	10 x 10	10 x 10	10 x 10	15 x 15

* Humidi-MiZer models only

50HC

APPENDIX II. PHYSICAL DATA (CONT'D)

Table 23 (cont.) - PHYSICAL DATA

(COOLING)

3 - 6 TONS

		50HC*04	50HC*05	50HC*06	50HC*07	
50HC	Evaporator Fan and Motor Medium Static 3 phase	Motor Qty / Drive Type	1 / Belt	1 / Belt	1 / Belt	1 / Belt
		Max BHP	1.7	1.7	2.4	2.9
		RPM Range	770–1175	920–1303	1035–1466	733–949
		Motor Frame Size	48	56	56	56
		Fan Qty / Type	1 / Centrifugal	1 / Centrifugal	1 / Centrifugal	1 / Centrifugal
		Fan Diameter (in)	10 x 10	10 x 10	10 x 10	15 x 15
		Motor Qty / Drive Type	1 / Belt	1 / Belt	1 / Belt	–
		Max BHP	1.7	1.7	2.4	–
		RPM Range	770–1175	770–1175	1035–1466	–
	Motor Frame Size	48	48	56	–	
	Fan Qty / Type	1 / Centrifugal	1 / Centrifugal	1 / Centrifugal	–	
	Fan Diameter (in)	10 x 10	10 x 10	10 x 10	–	
	Motor Qty / Drive Type	1 / Belt	1 / Belt	1 / Belt	1 / Belt	
	Max BHP	2.4	2.9	2.9	4.7	
	RPM Range	1035–1466	1208–1639	1303–1687	909–1102	
	Motor Frame Size	56	56	56	14	
	Fan Qty / Type	1 / Centrifugal	1 / Centrifugal	1 / Centrifugal	1 / Centrifugal	
	Fan Diameter (in)	10 x 10	10 x 10	10 x 10	15 x 15	
Cond. Coil		Material (Tube/Fin)	Cu / Al	Cu / Al	Cu / Al	Cu / Al
		Coil type	3/8–in RTPF	3/8–in RTPF	3/8–in RTPF	3/8–in RTPF
		Rows / FPI	2 / 17	2 / 17	2 / 17	2 / 17
		Total Face Area (ft ²)	12.7	21.3	21.3	20.5
Cond. fan / motor		Qty / Motor Drive Type	1/ Direct	1/ Direct	1/ Direct	2/ Direct
		Motor HP / RPM	1/8 / 825	1/4 / 1100	1/4 / 1100	1/4 / 1100
		Fan diameter (in)	22	22	22	22
Filters		RA Filter # / Size (in)	2 / 16 x 25 x 2	4 / 16 x 16 x 2	4 / 16 x 16 x 2	4 / 16 x 20 x 2
		OA inlet screen # / Size (in)	1 / 20 x 24 x 1	1 / 20 x 24 x 1	1 / 20 x 24 x 1	1 / 20 x 36 x 1

* Humidi–MiZer models only

– Not applicable

– Not applicable

APPENDIX II. PHYSICAL DATA (cont.)

Table 23 - PHYSICAL DATA
(COOLING)
7.5-12.5 TONS

		50HC*08	50HC*09	50HC*11	50HC*12	50HC*14
Refrigeration System						
# Circuits / # Comp. / Type		2 / 2 / Scroll	2 / 2 / Scroll	2 / 2 / Scroll	2 / 2 / Scroll	2 / 2 / Scroll
Puron Refrig (R-410A) charge A/B (lbs-oz)		9 - 10 / 9 - 10	9 - 14 / 9 - 14	12 - 10 / 13 - 0	12 - 11 / 12 - 5	16 - 7 / 15 - 5
Humidi-MiZer Puron Refrig (R-410A) charge A/B (lbs-oz)		17-0 / 17-0	15-2 / 15-0	18-0 / 18-0	18-3 / 17-3	25-8 / 22-8
Metering device		TXV	TXV	TXV	TXV	TXV
High-press. Trip / Reset (psig)		630 / 505	630 / 505	630 / 505	630 / 505	630 / 505
Low-press. Trip / Reset (psig)		54 / 117	54 / 117	27 / 44	54 / 117	54 / 117
Compressor Capacity Staging (%)		50% / 100%	50% / 100%	50% / 100%	50% / 100%	50% / 100%
Evaporator Coil						
Material (Tube/Fin)		Cu / Al	Cu / Al	Cu / Al	Cu / Al	Cu / Al
Coil type		3/8-in RTPF	3/8-in RTPF	3/8-in RTPF	3/8-in RTPF	3/8-in RTPF
Rows / FPI		4 / 15	4 / 15	4 / 15	4 / 15	4 / 15
total face area (ft ²)		11.1	11.1	11.1	11.1	17.5
Condensate drain conn. size		3/4-in	3/4-in	3/4-in	3/4-in	3/4-in
Humidi-MiZer Coil						
Material (Tube/Fin)		Cu / Al	Cu / Al	Cu / Al	Cu / Al	Cu / Al
Coil type		3/8-in RTPF	3/8-in RTPF	3/8-in RTPF	3/8-in RTPF	3/8-in RTPF
Rows / FPI		2 / 17	2 / 17	2 / 17	2 / 17	1 / 17
total face area (ft ²)		6.3	8.4	8.6	8.6	13.8
Evaporator fan and motor						
Standard Static 3 phase	Motor Qty / Drive type	1 / Belt	1 / Belt	1 / Belt	1 / Belt	1 / Belt
	Max BHP	1.7	1.7	2.4	2.4	2.9
	RPM range	518-733	518-733	591-838	591-838	440-609
	Motor Frame Size	56	56	56	56	56Y
	Fan Qty / Type	1 / Centrifugal	1 / Centrifugal	1 / Centrifugal	1 / Centrifugal	1 / Centrifugal
	Fan Diameter (in)	15 x 15	15 x 15	15 x 15	15 x 15	18 x 18
Medium Static 3 phase	Motor Qty / Drive type	1 / Belt	1 / Belt	1 / Belt	1 / Belt	1 / Belt
	Max BHP	2.4	2.4	3.7	3.7	3.7
	RPM range	690-936	690-936	838-1084	838-1084	609-778
	Motor Frame Size	56	56	56HZ	56HZ	56HZ
	Fan Qty / Type	1 / Centrifugal	1 / Centrifugal	1 / Centrifugal	1 / Centrifugal	1 / Centrifugal
	Fan Diameter (in)	15 x 15	15 x 15	15 x 15	15 x 15	18 x 18
High Static 3 phase	Motor Qty / Drive type	1 / Belt	1 / Belt	1 / Belt	1 / Belt	1 / Belt
	Max BHP	3.7	3.7	4.9	4.9	6.1
	RPM range	838-1084	838-1084	1022-1240	1022-1240	776-955
	Motor Frame Size	56	56	145TY	145TY	S184T
	Fan Qty / Type	1 / Centrifugal	1 / Centrifugal	1 / Centrifugal	1 / Centrifugal	1 / Centrifugal
	Fan Diameter (in)	15 x 15	15 x 15	15 x 15	15 x 15	18 x 18
Condenser Coil						
Material (Tube/Fin)		Cu / Al	Cu / Al	Cu / Al	Cu / Al	Cu / Al
Coil type		3/8-in RTPF	3/8-in RTPF	3/8-in RTPF	3/8-in RTPF	3/8-in RTPF
Rows / FPI		2 / 17	2 / 17	3 / 17	3 / 17	2 / 17
Total Face Area (ft ²)		25.1	25.1	25.1	25.1	2 at 23.1
Condenser fan / motor						
Qty / Motor drive type		2 / direct	2 / direct	1 / direct ECM	1 / direct	3 / direct
Motor HP / RPM		1/4 / 1100	1/4 / 1100	1 / 1050	1 / 1175	1/4 / 1100
Fan diameter (in)		22	22	30	30	22
Filters						
RA Filter # / size (in)		4 / 20 x 20 x 2	4 / 20 x 20 x 2	4 / 20 x 20 x 2	4 / 20 x 20 x 2	6 / 18 x 24 x 2 Vert 2/24 x 27 x 1
OA inlet screen # / size (in)		1 / 20 x 24 x 1	1 / 20 x 24 x 1	1 / 20 x 24 x 1	1 / 20 x 24 x 1	Horz 1/30 x 39 x 1

50HC

APPENDIX III. FAN PERFORMANCE

Table 13 – 50HC Size 04

1 Phase HUMIDI-MIZER

3 Ton Vertical Supply

CFM	Available External Static Pressure (in. wg)									
	0.2		0.4		0.6		0.8		1.0	
	RPM	BHP	RPM	BHP	RPM	BHP	RPM	BHP	RPM	BHP
900	594	0.15	740	0.25	867	0.37	981	0.52	1084	0.68
975	618	0.17	758	0.28	881	0.40	991	0.55	1092	0.71
1050	642	0.19	777	0.30	896	0.43	1003	0.58	1102	0.75
1125	668	0.22	797	0.34	912	0.47	1017	0.62	1113	0.79
1200	695	0.25	818	0.37	930	0.51	1032	0.66	1126	0.83
1275	722	0.29	841	0.41	949	0.55	1048	0.71	1140	0.88
1350	750	0.33	864	0.46	968	0.60	1065	0.76	1155	0.93
1425	778	0.37	888	0.50	989	0.65	1083	0.81	1171	0.99
1500	807	0.42	913	0.56	1011	0.71	1103	0.87	1188	1.05

CFM	Available External Static Pressure (in. wg)									
	1.2		1.4		1.6		1.8		2.0	
	RPM	BHP	RPM	BHP	RPM	BHP	RPM	BHP	RPM	BHP
900	1180	0.86	1269	1.05	–	–	–	–	–	–
975	1186	0.89	1275	1.08	–	–	–	–	–	–
1050	1194	0.92	1281	1.12	–	–	–	–	–	–
1125	1204	0.97	1289	1.16	–	–	–	–	–	–
1200	1215	1.01	–	–	–	–	–	–	–	–
1275	1227	1.06	–	–	–	–	–	–	–	–
1350	1240	1.12	–	–	–	–	–	–	–	–
1425	1254	1.18	–	–	–	–	–	–	–	–
1500	–	–	–	–	–	–	–	–	–	–

NOTE: For more information, see General Fan Performance Notes.

Boldface indicates field – supplied drive is required.

Standard static 560–854 RPM, 1.2 BHP max

Medium static 770–1175 RPM, 1.2 BHP max

High static – N/A

Table 14 – 50HC Size 04

3 Phase Non-HUMIDI-MIZER

3 Ton Vertical Supply

CFM	Available External Static Pressure (in. wg)									
	0.2		0.4		0.6		0.8		1.0	
	RPM	BHP	RPM	BHP	RPM	BHP	RPM	BHP	RPM	BHP
900	594	0.15	740	0.25	867	0.37	981	0.52	1084	0.68
975	618	0.17	758	0.28	881	0.40	991	0.55	1092	0.71
1050	642	0.19	777	0.30	896	0.43	1003	0.58	1102	0.75
1125	668	0.22	797	0.34	912	0.47	1017	0.62	1113	0.79
1200	695	0.25	818	0.37	930	0.51	1032	0.66	1126	0.83
1275	722	0.29	841	0.41	949	0.55	1048	0.71	1140	0.88
1350	750	0.33	864	0.46	968	0.60	1065	0.76	1155	0.93
1425	778	0.37	888	0.50	989	0.65	1083	0.81	1171	0.99
1500	807	0.42	913	0.56	1011	0.71	1103	0.87	1188	1.05

CFM	Available External Static Pressure (in. wg)									
	1.2		1.4		1.6		1.8		2.0	
	RPM	BHP	RPM	BHP	RPM	BHP	RPM	BHP	RPM	BHP
900	1180	0.86	1269	1.05	1354	1.25	1434	1.47	1511	1.70
975	1186	0.89	1275	1.08	1358	1.29	1437	1.51	1513	1.74
1050	1194	0.92	1281	1.12	1363	1.32	1441	1.54	1516	1.78
1125	1204	0.97	1289	1.16	1370	1.37	1447	1.59	1520	1.82
1200	1215	1.01	1298	1.21	1378	1.42	1454	1.64	1526	1.87
1275	1227	1.06	1309	1.26	1387	1.47	1462	1.69	1533	1.92
1350	1240	1.12	1321	1.32	1397	1.53	1471	1.75	1541	1.99
1425	1254	1.18	1333	1.38	1409	1.59	1481	1.82	–	–
1500	1270	1.24	1347	1.45	1421	1.66	1492	1.89	–	–

NOTE: For more information, see General Fan Performance Notes.

Boldface indicates field – supplied drive is required.

Medium static 770–1175 RPM, 1.2 BHP max

High static 1035–1466 RPM, 2.4 BHP max

APPENDIX III. FAN PERFORMANCE (cont.)

Table 15 – 50HC Size 04

3 Phase HUMIDI-MIZER

3 Ton Vertical Supply

CFM	Available External Static Pressure (in. wg)									
	0.2		0.4		0.6		0.8		1.0	
	RPM	BHP	RPM	BHP	RPM	BHP	RPM	BHP	RPM	BHP
900	594	0.15	740	0.25	867	0.37	981	0.52	1084	0.68
975	618	0.17	758	0.28	881	0.40	991	0.55	1092	0.71
1050	642	0.19	777	0.30	896	0.43	1003	0.58	1102	0.75
1125	668	0.22	797	0.34	912	0.47	1017	0.62	1113	0.79
1200	695	0.25	818	0.37	930	0.51	1032	0.66	1126	0.83
1275	722	0.29	841	0.41	949	0.55	1048	0.71	1140	0.88
1350	750	0.33	864	0.46	968	0.60	1065	0.76	1155	0.93
1425	778	0.37	888	0.50	989	0.65	1083	0.81	1171	0.99
1500	807	0.42	913	0.56	1011	0.71	1103	0.87	1188	1.05

CFM	Available External Static Pressure (in. wg)									
	1.2		1.4		1.6		1.8		2.0	
	RPM	BHP	RPM	BHP	RPM	BHP	RPM	BHP	RPM	BHP
900	1180	0.86	1269	1.05	1354	1.25	1434	1.47	1511	1.70
975	1186	0.89	1275	1.08	1358	1.29	1437	1.51	1513	1.74
1050	1194	0.92	1281	1.12	1363	1.32	1441	1.54	1516	1.78
1125	1204	0.97	1289	1.16	1370	1.37	1447	1.59	1520	1.82
1200	1215	1.01	1298	1.21	1378	1.42	1454	1.64	1526	1.87
1275	1227	1.06	1309	1.26	1387	1.47	1462	1.69	1533	1.92
1350	1240	1.12	1321	1.32	1397	1.53	1471	1.75	1541	1.99
1425	1254	1.18	1333	1.38	1409	1.59	1481	1.82	–	–
1500	1270	1.24	1347	1.45	1421	1.66	1492	1.89	–	–

NOTE: For more information, see General Fan Performance Notes.

Boldface indicates field – supplied drive is required.

Standard static 560–854 RPM, 1.2 BHP max

Medium static 770–1175 RPM, 1.2 BHP max

High static N/A

50HC

Table 16 – 50HC Size 04

1 Phase HUMIDI-MIZER

3 Ton Horizontal Supply

CFM	Available External Static Pressure (in. wg)									
	0.2		0.4		0.6		0.8		1.0	
	RPM	BHP	RPM	BHP	RPM	BHP	RPM	BHP	RPM	BHP
900	574	0.13	707	0.23	817	0.34	913	0.47	999	0.61
975	597	0.15	727	0.25	835	0.37	929	0.50	1015	0.64
1050	621	0.18	747	0.28	853	0.40	946	0.53	1030	0.68
1125	646	0.20	768	0.31	872	0.43	964	0.57	1047	0.72
1200	671	0.23	790	0.34	892	0.47	982	0.61	1064	0.76
1275	696	0.26	812	0.38	912	0.51	1001	0.65	1082	0.81
1350	723	0.30	835	0.42	933	0.55	1020	0.70	1100	0.86
1425	749	0.34	859	0.46	955	0.60	1040	0.75	1119	0.91
1500	776	0.38	883	0.51	977	0.65	1061	0.80	1138	0.97

CFM	Available External Static Pressure (in. wg)									
	1.2		1.4		1.6		1.8		2.0	
	RPM	BHP	RPM	BHP	RPM	BHP	RPM	BHP	RPM	BHP
900	1078	0.77	1151	0.93	1220	1.11	–	–	–	–
975	1093	0.80	1165	0.97	1233	1.15	–	–	–	–
1050	1108	0.84	1180	1.01	1247	1.19	–	–	–	–
1125	1123	0.88	1195	1.05	–	–	–	–	–	–
1200	1140	0.92	1210	1.10	–	–	–	–	–	–
1275	1157	0.97	1226	1.15	–	–	–	–	–	–
1350	1174	1.02	1243	1.20	–	–	–	–	–	–
1425	1192	1.08	–	–	–	–	–	–	–	–
1500	1210	1.14	–	–	–	–	–	–	–	–

NOTE: For more information, see General Fan Performance Notes.

Boldface indicates field – supplied drive is required.

Standard static 560–854 RPM, 1.2 BHP max

Medium static 770–1175 RPM, 1.2 BHP max

High static N/A

APPENDIX III. FAN PERFORMANCE (cont.)

Table 17 – 50HC Size 04

3 Phase NON-HUMIDI-MIZER

3 Ton Horizontal Supply

CFM	Available External Static Pressure (in. wg)									
	0.2		0.4		0.6		0.8		1.0	
	RPM	BHP	RPM	BHP	RPM	BHP	RPM	BHP	RPM	BHP
900	574	0.13	707	0.23	817	0.34	913	0.47	999	0.61
975	597	0.15	727	0.25	835	0.37	929	0.50	1015	0.64
1050	621	0.18	747	0.28	853	0.40	946	0.53	1030	0.68
1125	646	0.20	768	0.31	872	0.43	964	0.57	1047	0.72
1200	671	0.23	790	0.34	892	0.47	982	0.61	1064	0.76
1275	696	0.26	812	0.38	912	0.51	1001	0.65	1082	0.81
1350	723	0.30	835	0.42	933	0.55	1020	0.70	1100	0.86
1425	749	0.34	859	0.46	955	0.60	1040	0.75	1119	0.91
1500	776	0.38	883	0.51	977	0.65	1061	0.80	1138	0.97

CFM	Available External Static Pressure (in. wg)									
	1.2		1.4		1.6		1.8		2.0	
	RPM	BHP	RPM	BHP	RPM	BHP	RPM	BHP	RPM	BHP
900	1078	0.77	1151	0.93	1220	1.11	1284	1.30	1346	1.49
975	1093	0.80	1165	0.97	1233	1.15	1297	1.33	1358	1.53
1050	1108	0.84	1180	1.01	1247	1.19	1311	1.38	1371	1.58
1125	1123	0.88	1195	1.05	1261	1.23	1325	1.42	1385	1.62
1200	1140	0.92	1210	1.10	1276	1.28	1339	1.47	1399	1.68
1275	1157	0.97	1226	1.15	1292	1.33	1354	1.53	1414	1.73
1350	1174	1.02	1243	1.20	1308	1.39	1370	1.59	1429	1.80
1425	1192	1.08	1260	1.26	1325	1.45	1386	1.65	1444	1.86
1500	1210	1.14	1278	1.33	1342	1.52	1403	1.72	1461	1.93

NOTE: For more information, see General Fan Performance Notes.

Boldface indicates field – supplied drive is required.

Medium static 770–1175 RPM, 1.7 BHP max

High static 1035–1466 RPM, 2.4 BHP max

Table 18 – 50HC Size 04

3 Phase HUMIDI-MIZER

3 Ton Horizontal Supply

CFM	Available External Static Pressure (in. wg)									
	0.2		0.4		0.6		0.8		1.0	
	RPM	BHP	RPM	BHP	RPM	BHP	RPM	BHP	RPM	BHP
900	574	0.13	707	0.23	817	0.34	913	0.47	999	0.61
975	597	0.15	727	0.25	835	0.37	929	0.50	1015	0.64
1050	621	0.18	747	0.28	853	0.40	946	0.53	1030	0.68
1125	646	0.20	768	0.31	872	0.43	964	0.57	1047	0.72
1200	671	0.23	790	0.34	892	0.47	982	0.61	1064	0.76
1275	696	0.26	812	0.38	912	0.51	1001	0.65	1082	0.81
1350	723	0.30	835	0.42	933	0.55	1020	0.70	1100	0.86
1425	749	0.34	859	0.46	955	0.60	1040	0.75	1119	0.91
1500	776	0.38	883	0.51	977	0.65	1061	0.80	1138	0.97

CFM	Available External Static Pressure (in. wg)									
	1.2		1.4		1.6		1.8		2.0	
	RPM	BHP	RPM	BHP	RPM	BHP	RPM	BHP	RPM	BHP
900	1078	0.77	1151	0.93	1220	1.11	1284	1.30	1346	1.49
975	1093	0.80	1165	0.97	1233	1.15	1297	1.33	1358	1.53
1050	1108	0.84	1180	1.01	1247	1.19	1311	1.38	1371	1.58
1125	1123	0.88	1195	1.05	1261	1.23	1325	1.42	1385	1.62
1200	1140	0.92	1210	1.10	1276	1.28	1339	1.47	1399	1.68
1275	1157	0.97	1226	1.15	1292	1.33	1354	1.53	1414	1.73
1350	1174	1.02	1243	1.20	1308	1.39	1370	1.59	1429	1.80
1425	1192	1.08	1260	1.26	1325	1.45	1386	1.65	1444	1.86
1500	1210	1.14	1278	1.33	1342	1.52	1403	1.72	1461	1.93

NOTE: For more information, see General Fan Performance Notes.

Boldface indicates field – supplied drive is required.

Standard Static 560–854 RPM, 1.7 BHP max

Medium Static 770–1175 RPM, 1.7 BHP max

High Static 1035–1466 RPM, 2.4 BHP max

APPENDIX III. FAN PERFORMANCE (cont.)

Table 19 – 50HC Size 05

1 Phase HUMIDI-MIZER

4 Ton Vertical Supply

CFM	Available External Static Pressure (in. wg)									
	0.2		0.4		0.6		0.8		1.0	
	RPM	BHP	RPM	BHP	RPM	BHP	RPM	BHP	RPM	BHP
1200	695	0.25	818	0.37	930	0.51	1032	0.66	1126	0.83
1300	731	0.30	849	0.43	955	0.57	1053	0.72	1145	0.89
1400	769	0.36	880	0.49	982	0.63	1077	0.79	1166	0.97
1500	807	0.42	913	0.56	1011	0.71	1103	0.87	1188	1.05
1600	847	0.49	948	0.63	1042	0.79	1130	0.96	1213	1.14
1700	887	0.57	983	0.72	1073	0.88	1158	1.06	–	–
1800	928	0.66	1020	0.82	1106	0.98	1188	1.16	–	–
1900	969	0.76	1057	0.92	1140	1.09	–	–	–	–
2000	1010	0.87	1095	1.04	1175	1.21	–	–	–	–

CFM	Available External Static Pressure (in. wg)									
	1.2		1.4		1.6		1.8		2.0	
	RPM	BHP	RPM	BHP	RPM	BHP	RPM	BHP	RPM	BHP
1200	1215	1.01	1298	1.21	–	–	–	–	–	–
1300	1231	1.08	–	–	–	–	–	–	–	–
1400	1249	1.16	–	–	–	–	–	–	–	–
1500	–	–	–	–	–	–	–	–	–	–
1600	–	–	–	–	–	–	–	–	–	–
1700	–	–	–	–	–	–	–	–	–	–
1800	–	–	–	–	–	–	–	–	–	–
1900	–	–	–	–	–	–	–	–	–	–
2000	–	–	–	–	–	–	–	–	–	–

NOTE: For more information, see General Fan Performance Notes.

Boldface indicates field – supplied drive is required.

Standard static 560–854 RPM, 1.2 BHP max

Medium static 770–1175 RPM, 1.2 BHP max

Table 20 – 50HC Size 05

3 Phase Non-HUMIDI-MIZER

4 Ton Vertical Supply

CFM	Available External Static Pressure (in. wg)									
	0.2		0.4		0.6		0.8		1.0	
	RPM	BHP	RPM	BHP	RPM	BHP	RPM	BHP	RPM	BHP
1200	695	0.25	818	0.37	930	0.51	1032	0.66	1126	0.83
1300	731	0.30	849	0.43	955	0.57	1053	0.72	1145	0.89
1400	769	0.36	880	0.49	982	0.63	1077	0.79	1166	0.97
1500	807	0.42	913	0.56	1011	0.71	1103	0.87	1188	1.05
1600	847	0.49	948	0.63	1042	0.79	1130	0.96	1213	1.14
1700	887	0.57	983	0.72	1073	0.88	1158	1.06	1239	1.24
1800	928	0.66	1020	0.82	1106	0.98	1188	1.16	1266	1.35
1900	969	0.76	1057	0.92	1140	1.09	1219	1.28	1295	1.48
2000	1010	0.87	1095	1.04	1175	1.21	1251	1.41	1325	1.61

CFM	Available External Static Pressure (in. wg)									
	1.2		1.4		1.6		1.8		2.0	
	RPM	BHP	RPM	BHP	RPM	BHP	RPM	BHP	RPM	BHP
1200	1215	1.01	1298	1.21	1378	1.42	1454	1.64	1526	1.87
1300	1231	1.08	1313	1.28	1390	1.49	1465	1.71	1536	1.94
1400	1249	1.16	1329	1.36	1405	1.57	1478	1.79	1547	2.03
1500	1270	1.24	1347	1.45	1421	1.66	1492	1.89	1561	2.13
1600	1292	1.34	1367	1.54	1440	1.76	1509	1.99	1576	2.23
1700	1315	1.44	1389	1.65	1459	1.88	1527	2.11	1593	2.35
1800	1341	1.56	1412	1.77	1481	2.00	1547	2.23	1612	2.48
1900	1367	1.68	1437	1.90	1504	2.13	1569	2.37	1632	2.62
2000	1395	1.82	1463	2.04	1528	2.28	1591	2.52	1653	2.77

NOTE: For more information, see General Fan Performance Notes.

Boldface indicates field – supplied drive is required.

Medium Static 920–1303 RPM, 1.7 BHP max

High Static 1208–1639 RPM, 2.9 BHP max

50HC

APPENDIX III. FAN PERFORMANCE (cont.)

Table 21 – 50HC Size 05

3 Phase HUMIDI-MIZER

4 Ton Vertical Supply

CFM	Available External Static Pressure (in. wg)									
	0.2		0.4		0.6		0.8		1.0	
	RPM	BHP	RPM	BHP	RPM	BHP	RPM	BHP	RPM	BHP
1200	695	0.25	818	0.37	930	0.51	1032	0.66	1126	0.83
1300	731	0.30	849	0.43	955	0.57	1053	0.72	1145	0.89
1400	769	0.36	880	0.49	982	0.63	1077	0.79	1166	0.97
1500	807	0.42	913	0.56	1011	0.71	1103	0.87	1188	1.05
1600	847	0.49	948	0.63	1042	0.79	1130	0.96	1213	1.14
1700	887	0.57	983	0.72	1073	0.88	1158	1.06	1239	1.24
1800	928	0.66	1020	0.82	1106	0.98	1188	1.16	1266	1.35
1900	969	0.76	1057	0.92	1140	1.09	1219	1.28	1295	1.48
2000	1010	0.87	1095	1.04	1175	1.21	1251	1.41	1325	1.61

CFM	Available External Static Pressure (in. wg)									
	1.2		1.4		1.6		1.8		2.0	
	RPM	BHP	RPM	BHP	RPM	BHP	RPM	BHP	RPM	BHP
1200	1215	1.01	1298	1.21	1378	1.42	1454	1.64	1526	1.87
1300	1231	1.08	1313	1.28	1390	1.49	1465	1.71	1536	1.94
1400	1249	1.16	1329	1.36	1405	1.57	1478	1.79	1547	2.03
1500	1270	1.24	1347	1.45	1421	1.66	1492	1.89	-	-
1600	1292	1.34	1367	1.54	1440	1.76	1509	1.99	-	-
1700	1315	1.44	1389	1.65	1459	1.88	1527	2.11	-	-
1800	1341	1.56	1412	1.77	1481	2.00	1547	2.23	-	-
1900	1367	1.68	1437	1.90	1504	2.13	-	-	-	-
2000	1395	1.82	1463	2.04	1528	2.28	-	-	-	-

NOTE: For more information, see General Fan Performance Notes.

Boldface indicates field – supplied drive is required.

Standard Static 560–854 RPM, 1.7 BHP max

Medium Static 770–1175 RPM, 1.7 BHP max

High Static 1208–1550 RPM, 2.9 BHP max

Table 22 – 50HC Size 05

1 Phase HUMIDI-MIZER

4 Ton Horizontal Supply

CFM	Available External Static Pressure (in. wg)									
	0.2		0.4		0.6		0.8		1.0	
	RPM	BHP	RPM	BHP	RPM	BHP	RPM	BHP	RPM	BHP
1200	671	0.23	790	0.34	892	0.47	982	0.61	1064	0.76
1300	705	0.28	820	0.39	919	0.52	1007	0.67	1088	0.82
1400	740	0.33	851	0.45	947	0.58	1034	0.73	1113	0.89
1500	776	0.38	883	0.51	977	0.65	1061	0.80	1138	0.97
1600	813	0.45	916	0.58	1007	0.73	1089	0.89	1165	1.05
1700	851	0.52	949	0.66	1038	0.81	1118	0.97	1192	1.15
1800	888	0.60	984	0.75	1069	0.90	1148	1.07	-	-
1900	957	0.69	1019	0.84	1102	1.00	1179	1.18	-	-
2000	965	0.78	1054	0.94	1135	1.11	-	-	-	-

CFM	Available External Static Pressure (in. wg)									
	1.2		1.4		1.6		1.8		2.0	
	RPM	BHP	RPM	BHP	RPM	BHP	RPM	BHP	RPM	BHP
1200	1140	0.92	1210	1.10	-	-	-	-	-	-
1300	1162	0.99	1232	1.16	-	-	-	-	-	-
1400	1186	1.06	-	-	-	-	-	-	-	-
1500	1210	1.14	-	-	-	-	-	-	-	-
1600	-	-	-	-	-	-	-	-	-	-
1700	-	-	-	-	-	-	-	-	-	-
1800	-	-	-	-	-	-	-	-	-	-
1900	-	-	-	-	-	-	-	-	-	-
2000	-	-	-	-	-	-	-	-	-	-

NOTE: For more information, see General Fan Performance Notes.

Boldface indicates field – supplied drive is required.

Standard static 560–854 RPM, 1.2 BHP max

Medium static 770–1175 RPM, 1.2 BHP max

50HC

APPENDIX III. FAN PERFORMANCE (cont.)

Table 23 – 50HC Size 05

3 Phase Non-HUMIDI-MIZER

4 Ton Horizontal Supply

CFM	Available External Static Pressure (in. wg)									
	0.2		0.4		0.6		0.8		1.0	
	RPM	BHP	RPM	BHP	RPM	BHP	RPM	BHP	RPM	BHP
1200	671	0.23	790	0.34	892	0.47	982	0.61	1064	0.76
1300	705	0.28	820	0.39	919	0.52	1007	0.67	1088	0.82
1400	740	0.33	851	0.45	947	0.58	1034	0.73	1113	0.89
1500	776	0.38	883	0.51	977	0.65	1061	0.80	1138	0.97
1600	813	0.45	916	0.58	1007	0.73	1089	0.89	1165	1.05
1700	851	0.52	949	0.66	1038	0.81	1118	0.97	1192	1.15
1800	888	0.60	984	0.75	1069	0.90	1148	1.07	1221	1.25
1900	927	0.69	1019	0.84	1102	1.00	1179	1.18	1250	1.36
2000	965	0.78	1054	0.94	1135	1.11	1210	1.29	1280	1.48

CFM	Available External Static Pressure (in. wg)									
	1.2		1.4		1.6		1.8		2.0	
	RPM	BHP	RPM	BHP	RPM	BHP	RPM	BHP	RPM	BHP
1200	1140	0.92	1210	1.10	1276	1.28	1339	1.47	1399	1.68
1300	1162	0.99	1232	1.16	1297	1.35	1360	1.55	1419	1.75
1400	1186	1.06	1254	1.24	1319	1.43	1381	1.63	1439	1.84
1500	1210	1.14	1278	1.33	1342	1.52	1403	1.72	1461	1.93
1600	1236	1.23	1302	1.42	1365	1.62	1425	1.82	1483	2.04
1700	1262	1.33	1328	1.52	1390	1.72	1449	1.93	1505	2.15
1800	1289	1.44	1354	1.63	1415	1.84	1473	2.05	1529	2.27
1900	1317	1.55	1380	1.75	1441	1.96	1498	2.18	1553	2.41
2000	1345	1.68	1408	1.88	1467	2.10	1524	2.32	1579	2.55

NOTE: For more information, see General Fan Performance Notes.

Boldface indicates field – supplied drive is required.

Medium Static 920–1303 RPM, 1.7 BHP max

High Static 1208–1639 RPM, 2.9 max BHP

Table 24 – 50HC Size 05

3 Phase HUMIDI-MIZER

4 Ton Horizontal Supply

CFM	Available External Static Pressure (in. wg)									
	0.2		0.4		0.6		0.8		1.0	
	RPM	BHP	RPM	BHP	RPM	BHP	RPM	BHP	RPM	BHP
1200	671	0.23	790	0.34	892	0.47	982	0.61	1064	0.76
1300	705	0.28	820	0.39	919	0.52	1007	0.67	1088	0.82
1400	740	0.33	851	0.45	947	0.58	1034	0.73	1113	0.89
1500	776	0.38	883	0.51	977	0.65	1061	0.80	1138	0.97
1600	813	0.45	916	0.58	1007	0.73	1089	0.89	1165	1.05
1700	851	0.52	949	0.66	1038	0.81	1118	0.97	1192	1.15
1800	888	0.60	984	0.75	1069	0.90	1148	1.07	1221	1.25
1900	927	0.69	1019	0.84	1102	1.00	1179	1.18	1250	1.36
2000	965	0.78	1054	0.94	1135	1.11	1210	1.29	1280	1.48

CFM	Available External Static Pressure (in. wg)									
	1.2		1.4		1.6		1.8		2.0	
	RPM	BHP	RPM	BHP	RPM	BHP	RPM	BHP	RPM	BHP
1200	1140	0.92	1210	1.10	1276	1.28	1339	1.47	1399	1.68
1300	1162	0.99	1232	1.16	1297	1.35	1360	1.55	1419	1.75
1400	1186	1.06	1254	1.24	1319	1.43	1381	1.63	1439	1.84
1500	1210	1.14	1278	1.33	1342	1.52	1403	1.72	1461	1.93
1600	1236	1.23	1302	1.42	1365	1.62	1425	1.82	1483	2.04
1700	1262	1.33	1328	1.52	1390	1.72	1449	1.93	1505	2.15
1800	1289	1.44	1354	1.63	1415	1.84	1473	2.05	1529	2.27
1900	1317	1.55	1380	1.75	1441	1.96	1498	2.18	–	–
2000	1345	1.68	1408	1.88	1467	2.10	1524	2.32	–	–

NOTE: For more information, see General Fan Performance Notes.

Boldface indicates field – supplied drive is required.

Standard Static 560–854 RPM, 1.7 BHP max

Medium Static 770–1175 RPM, 1.7 BHP max

High Static 1208–1550 RPM, 2.9 BHP max

50HC

APPENDIX III. FAN PERFORMANCE (cont.)

Table 25 – 50HC Size 06

1 Phase HUMIDI-MIZER

5 Ton Vertical Supply

CFM	Available External Static Pressure (in. wg)									
	0.2		0.4		0.6		0.8		1.0	
	RPM	BHP	RPM	BHP	RPM	BHP	RPM	BHP	RPM	BHP
1500	794	0.41	902	0.55	993	0.69	1074	0.85	1147	1.00
1625	840	0.49	945	0.64	1034	0.80	1113	0.96	1185	1.13
1750	888	0.59	988	0.75	1075	0.92	1153	1.09	1223	1.26
1875	936	0.70	1033	0.87	1117	1.05	1193	1.23	1263	1.41
2000	984	0.82	1078	1.00	1160	1.19	1235	1.39	-	-
2125	1033	0.96	1124	1.15	1204	1.35	-	-	-	-
2250	1083	1.11	1170	1.32	1248	1.53	-	-	-	-
2375	1133	1.28	1217	1.50	-	-	-	-	-	-
2500	1183	1.47	-	-	-	-	-	-	-	-

CFM	Available External Static Pressure (in. wg)									
	1.2		1.4		1.6		1.8		2.0	
	RPM	BHP	RPM	BHP	RPM	BHP	RPM	BHP	RPM	BHP
1500	1214	1.16	1277	1.33	1336	1.50	-	-	-	-
1625	1251	1.30	1313	1.47	-	-	-	-	-	-
1750	1289	1.44	-	-	-	-	-	-	-	-
1875	-	-	-	-	-	-	-	-	-	-
2000	-	-	-	-	-	-	-	-	-	-
2125	-	-	-	-	-	-	-	-	-	-
2250	-	-	-	-	-	-	-	-	-	-
2375	-	-	-	-	-	-	-	-	-	-
2500	-	-	-	-	-	-	-	-	-	-

NOTE: For more information, see General Fan Performance Notes.

Boldface indicates field – supplied drive is required.

Standard static 770 – 1175 RPM, 1.2 BHP max

Medium static 1035 – 1466 RPM, 1.5 BHP max

Table 26 – 50HC Size 06

3 Phase Non-HUMIDI-MIZER

5 Ton Vertical Supply

CFM	Available External Static Pressure (in. wg)									
	0.2		0.4		0.6		0.8		1.0	
	RPM	BHP	RPM	BHP	RPM	BHP	RPM	BHP	RPM	BHP
1500	794	0.41	902	0.55	993	0.69	1074	0.85	1147	1.00
1625	840	0.49	945	0.64	1034	0.80	1113	0.96	1185	1.13
1750	888	0.59	988	0.75	1075	0.92	1153	1.09	1223	1.26
1875	936	0.70	1033	0.87	1117	1.05	1193	1.23	1263	1.41
2000	984	0.82	1078	1.00	1160	1.19	1235	1.39	1303	1.58
2125	1033	0.96	1124	1.15	1204	1.35	1277	1.56	1343	1.76
2250	1083	1.11	1170	1.32	1248	1.53	1319	1.74	1385	1.96
2375	1133	1.28	1217	1.50	1293	1.72	1363	1.95	1427	2.17
2500	1183	1.47	1265	1.70	1339	1.93	1406	2.17	1470	2.41

CFM	Available External Static Pressure (in. wg)									
	1.2		1.4		1.6		1.8		2.0	
	RPM	BHP	RPM	BHP	RPM	BHP	RPM	BHP	RPM	BHP
1500	1214	1.16	1277	1.33	1336	1.50	1392	1.67	1445	1.85
1625	1251	1.30	1313	1.47	1371	1.65	1427	1.83	1479	2.02
1750	1289	1.44	1350	1.63	1407	1.81	1462	2.01	1514	2.20
1875	1327	1.60	1387	1.80	1444	1.99	1498	2.19	1550	2.40
2000	1366	1.78	1426	1.98	1482	2.19	1535	2.40	1586	2.61
2125	1406	1.97	1464	2.18	1520	2.40	1573	2.62	1623	2.84
2250	1446	2.18	1504	2.40	1559	2.62	1611	2.85	1661	3.09
2375	1487	2.40	1544	2.63	1598	2.87	1650	3.11	-	-
2500	1529	2.64	1585	2.89	1638	3.13	-	-	-	-

NOTE: For more information, see General Fan Performance Notes.

Boldface indicates field – supplied drive is required.

Medium Static 1035 – 1466 RPM, 2.4 BHP max

High Static 1303 – 1687 RPM, 2.9 max BHP

APPENDIX III. FAN PERFORMANCE (cont.)

Table 27 – 50HC Size 06

3 Phase HUMIDI-MIZER

5 Ton Vertical Supply

CFM	Available External Static Pressure (in. wg)									
	0.2		0.4		0.6		0.8		1.0	
	RPM	BHP	RPM	BHP	RPM	BHP	RPM	BHP	RPM	BHP
1500	794	0.41	902	0.55	993	0.69	1074	0.85	1147	1.00
1625	840	0.49	945	0.64	1034	0.80	1113	0.96	1185	1.13
1750	888	0.59	988	0.75	1075	0.92	1153	1.09	1223	1.26
1875	936	0.70	1033	0.87	1117	1.05	1193	1.23	1263	1.41
2000	984	0.82	1078	1.00	1160	1.19	1235	1.39	1303	1.58
2125	1033	0.96	1124	1.15	1204	1.35	1277	1.56	1343	1.76
2250	1083	1.11	1170	1.32	1248	1.53	1319	1.74	1385	1.96
2375	1133	1.28	1217	1.50	1293	1.72	1363	1.95	1427	2.17
2500	1183	1.47	1265	1.70	1339	1.93	1406	2.17	1470	2.41

CFM	Available External Static Pressure (in. wg)									
	1.2		1.4		1.6		1.8		2.0	
	RPM	BHP	RPM	BHP	RPM	BHP	RPM	BHP	RPM	BHP
1500	1214	1.16	1277	1.33	1336	1.50	1392	1.67	1445	1.85
1625	1251	1.30	1313	1.47	1371	1.65	1427	1.83	1479	2.02
1750	1289	1.44	1350	1.63	1407	1.81	1462	2.01	1514	2.20
1875	1327	1.60	1387	1.80	1444	1.99	1498	2.19	1550	2.40
2000	1366	1.78	1426	1.98	1482	2.19	1535	2.40	-	-
2125	1406	1.97	1464	2.18	1520	2.40	-	-	-	-
2250	1446	2.18	1504	2.40	-	-	-	-	-	-
2375	1487	2.40	1544	2.63	-	-	-	-	-	-
2500	1529	2.64	-	-	-	-	-	-	-	-

NOTE: For more information, see General Fan Performance Notes.

Boldface indicates field – supplied drive is required.

- Standard Static 770–1175 RPM, 1.7 BHP max
- Medium Static 1035–1466 RPM, 2.4 BHP max
- High Static 1303–1550 RPM, 2.9 BHP max

50HC

Table 28 – 50HC Size 06

1 Phase HUMIDI-MIZER

5 Ton Horizontal Supply

CFM	Available External Static Pressure (in. wg)									
	0.2		0.4		0.6		0.8		1.0	
	RPM	BHP	RPM	BHP	RPM	BHP	RPM	BHP	RPM	BHP
1500	725	0.33	840	0.46	937	0.60	1023	0.75	1101	0.90
1625	765	0.40	876	0.54	970	0.68	1054	0.84	1131	1.00
1750	806	0.48	912	0.63	1004	0.78	1087	0.94	1162	1.11
1875	847	0.57	950	0.72	1039	0.88	1120	1.05	1194	1.23
2000	889	0.66	988	0.83	1075	1.00	1154	1.18	1226	1.36
2125	931	0.78	1027	0.95	1112	1.13	1189	1.31	1260	1.50
2250	974	0.90	1067	1.08	1149	1.27	1224	1.46	-	-
2375	1018	1.03	1107	1.23	1187	1.43	-	-	-	-
2500	1061	1.19	1148	1.39	-	-	-	-	-	-

CFM	Available External Static Pressure (in. wg)									
	1.2		1.4		1.6		1.8		2.0	
	RPM	BHP	RPM	BHP	RPM	BHP	RPM	BHP	RPM	BHP
1500	1172	1.06	1239	1.23	1302	1.40	-	-	-	-
1625	1201	1.16	1267	1.34	1329	1.52	-	-	-	-
1750	1231	1.28	1296	1.46	-	-	-	-	-	-
1875	1262	1.41	-	-	-	-	-	-	-	-
2000	-	-	-	-	-	-	-	-	-	-
2125	-	-	-	-	-	-	-	-	-	-
2250	-	-	-	-	-	-	-	-	-	-
2375	-	-	-	-	-	-	-	-	-	-
2500	-	-	-	-	-	-	-	-	-	-

APPENDIX III. FAN PERFORMANCE (cont.)

Table 29 – 50HC Size 06

3 Phase Non-HUMIDI-MIZER

5 Ton Horizontal Supply

CFM	Available External Static Pressure (in. wg)									
	0.2		0.4		0.6		0.8		1.0	
	RPM	BHP	RPM	BHP	RPM	BHP	RPM	BHP	RPM	BHP
1500	794	0.41	902	0.55	993	0.69	1074	0.85	1147	1.00
1625	840	0.49	945	0.64	1034	0.80	1113	0.96	1185	1.13
1750	888	0.59	988	0.75	1075	0.92	1153	1.09	1223	1.26
1875	936	0.70	1033	0.87	1117	1.05	1193	1.23	1263	1.41
2000	984	0.82	1078	1.00	1160	1.19	1235	1.39	1303	1.58
2125	1033	0.96	1124	1.15	1204	1.35	1277	1.56	1343	1.76
2250	1083	1.11	1170	1.32	1248	1.53	1319	1.74	1385	1.96
2375	1133	1.28	1217	1.50	1293	1.72	1363	1.95	1427	2.17
2500	1183	1.47	1265	1.70	1339	1.93	1406	2.17	1470	2.41

CFM	Available External Static Pressure (in. wg)									
	1.2		1.4		1.6		1.8		2.0	
	RPM	BHP	RPM	BHP	RPM	BHP	RPM	BHP	RPM	BHP
1500	1214	1.16	1277	1.33	1336	1.50	1392	1.67	1445	1.85
1625	1251	1.30	1313	1.47	1371	1.65	1427	1.83	1479	2.02
1750	1289	1.44	1350	1.63	1407	1.81	1462	2.01	1514	2.20
1875	1327	1.60	1387	1.80	1444	1.99	1498	2.19	1550	2.40
2000	1366	1.78	1426	1.98	1482	2.19	1535	2.40	1586	2.61
2125	1406	1.97	1464	2.18	1520	2.40	1573	2.62	1623	2.84
2250	1446	2.18	1504	2.40	1559	2.62	1611	2.85	1661	3.09
2375	1487	2.40	1544	2.63	1598	2.87	1650	3.11	-	-
2500	1529	2.64	1585	2.89	1638	3.13	-	-	-	-

NOTE: For more information, see General Fan Performance Notes.

Boldface indicates field – supplied drive is required.

Medium Static 1035 – 1466 RPM, 2.4 BHP max

High Static 1303 – 1687 RPM, 2.9 max BHP

Table 30 – 50HC Size 06

3 Phase HUMIDI-MIZER

5 Ton Horizontal Supply

CFM	Available External Static Pressure (in. wg)									
	0.2		0.4		0.6		0.8		1.0	
	RPM	BHP	RPM	BHP	RPM	BHP	RPM	BHP	RPM	BHP
1500	725	0.33	840	0.46	937	0.60	1023	0.75	1101	0.90
1625	765	0.40	876	0.54	970	0.68	1054	0.84	1131	1.00
1750	806	0.48	912	0.63	1004	0.78	1087	0.94	1162	1.11
1875	847	0.57	950	0.72	1039	0.88	1120	1.05	1194	1.23
2000	889	0.66	988	0.83	1075	1.00	1154	1.18	1226	1.36
2125	931	0.78	1027	0.95	1112	1.13	1189	1.31	1260	1.50
2250	974	0.90	1067	1.08	1149	1.27	1224	1.46	1294	1.66
2375	1018	1.03	1107	1.23	1187	1.43	1261	1.63	1329	1.84
2500	1061	1.19	1148	1.39	1226	1.59	1297	1.81	1364	2.02

CFM	Available External Static Pressure (in. wg)									
	1.2		1.4		1.6		1.8		2.0	
	RPM	BHP	RPM	BHP	RPM	BHP	RPM	BHP	RPM	BHP
1500	1172	1.06	1239	1.23	1302	1.40	1361	1.58	1418	1.77
1625	1201	1.16	1267	1.34	1329	1.52	1388	1.71	1444	1.90
1750	1231	1.28	1296	1.46	1358	1.65	1416	1.84	1472	2.04
1875	1262	1.41	1326	1.60	1387	1.79	1445	1.99	1499	2.20
2000	1294	1.55	1357	1.74	1417	1.95	1474	2.15	1528	2.36
2125	1326	1.70	1388	1.90	1447	2.11	1504	2.33	-	-
2250	1359	1.87	1420	2.08	1479	2.29	1534	2.51	-	-
2375	1393	2.05	1453	2.27	1511	2.49	-	-	-	-
2500	1427	2.24	1487	2.47	1543	2.70	-	-	-	-

NOTE: For more information, see General Fan Performance Notes.

Boldface indicates field – supplied drive is required.

Standard Static 770 – 1175 RPM 1.7 BHP max

Medium Static 1035 – 1466 2.4 BHP max

High Static 1303 – 1687 2.9 BHP max

APPENDIX III. FAN PERFORMANCE (cont.)

Table 31 – 50HC Size 07

3 Phase Non-HUMIDI-MIZER

6 Ton Vertical Supply

CFM	Available External Static Pressure (in. wg)									
	0.2		0.4		0.6		0.8		1.0	
	RPM	BHP	RPM	BHP	RPM	BHP	RPM	BHP	RPM	BHP
1800	446	0.33	534	0.50	609	0.70	676	0.91	736	1.14
1950	467	0.39	552	0.57	625	0.77	690	0.99	750	1.23
2100	489	0.45	571	0.64	642	0.86	706	1.08	764	1.33
2250	511	0.53	591	0.73	660	0.95	722	1.19	779	1.44
2400	534	0.61	611	0.82	678	1.05	739	1.30	795	1.56
2550	558	0.71	631	0.93	697	1.17	756	1.42	811	1.69
2700	581	0.81	652	1.04	716	1.29	774	1.55	828	1.83
2850	605	0.93	674	1.17	736	1.43	792	1.70	845	1.98
3000	630	1.06	696	1.31	756	1.58	811	1.86	863	2.15

CFM	Available External Static Pressure (in. wg)									
	1.2		1.4		1.6		1.8		2.0	
	RPM	BHP	RPM	BHP	RPM	BHP	RPM	BHP	RPM	BHP
1800	791	1.39	843	1.65	892	1.93	938	2.22	981	2.53
1950	804	1.49	855	1.76	903	2.04	949	2.34	992	2.65
2100	818	1.59	868	1.87	915	2.16	961	2.46	1003	2.78
2250	832	1.71	882	1.99	928	2.29	973	2.59	1015	2.92
2400	847	1.83	896	2.12	942	2.43	986	2.74	1028	3.07
2550	862	1.97	910	2.27	956	2.58	999	2.90	1041	3.23
2700	878	2.12	926	2.42	971	2.74	1013	3.07	1055	3.41
2850	895	2.28	941	2.59	986	2.92	1028	3.25	1069	3.60
3000	912	2.46	958	2.78	1001	3.11	1043	3.45	1083	3.80

NOTE: For more information, see General Fan Performance Notes.

Boldface indicates field – supplied drive is required.

- Standard Static 489–747 RPM, 1.7 BHP max
- Medium Static 733–949 RPM, 2.9 BHP max
- High Static 909–1102 RPM, 4.7 BHP max

50HC

Table 32 – 50HC Size 07

3 Phase Non-HUMIDI-MIZER

6 Ton Horizontal Supply

CFM	Available External Static Pressure (in. wg)									
	0.2		0.4		0.6		0.8		1.0	
	RPM	BHP	RPM	BHP	RPM	BHP	RPM	BHP	RPM	BHP
1800	415	0.28	510	0.46	588	0.65	655	0.85	715	1.08
1950	431	0.32	525	0.51	601	0.71	668	0.93	727	1.16
2100	448	0.38	540	0.57	615	0.78	681	1.01	740	1.25
2250	465	0.43	555	0.64	629	0.86	694	1.10	753	1.34
2400	483	0.49	571	0.71	644	0.94	708	1.19	766	1.45
2550	501	0.56	587	0.79	659	1.04	722	1.29	779	1.56
2700	519	0.64	603	0.88	674	1.14	737	1.40	793	1.68
2850	538	0.72	620	0.98	689	1.24	751	1.52	807	1.80
3000	557	0.82	637	1.08	705	1.36	766	1.64	822	1.94

CFM	Available External Static Pressure (in. wg)									
	1.2		1.4		1.6		1.8		2.0	
	RPM	BHP	RPM	BHP	RPM	BHP	RPM	BHP	RPM	BHP
1800	770	1.31	821	1.56	868	1.82	913	2.09	955	2.36
1950	782	1.40	832	1.66	879	1.92	924	2.20	966	2.49
2100	794	1.50	844	1.76	891	2.03	935	2.32	977	2.61
2250	806	1.60	856	1.87	903	2.15	947	2.45	988	2.75
2400	819	1.71	868	1.99	915	2.28	958	2.58	1000	2.89
2550	832	1.83	881	2.12	927	2.42	971	2.73	1012	3.05
2700	845	1.96	894	2.26	940	2.57	983	2.88	1024	3.21
2850	859	2.10	907	2.41	953	2.72	995	3.05	1036	3.38
3000	873	2.24	921	2.56	966	2.89	1008	3.22	1049	3.56

NOTE: For more information, see General Fan Performance Notes.

Boldface indicates field – supplied drive is required.

- Standard Static 489–747 RPM, 1.7 BHP max
- Medium Static 733–949 RPM, 2.9 BHP max
- High Static 909–1102 RPM, 4.7 BHP max

APPENDIX III. FAN PERFORMANCE (cont.)

Table 33 – 50HC Size 08

3 Phase Non-HUMIDI-MIZER

7.5 Ton Vertical Supply

CFM	Available External Static Pressure (in. wg)									
	0.2		0.4		0.6		0.8		1.0	
	RPM	BHP	RPM	BHP	RPM	BHP	RPM	BHP	RPM	BHP
2250	482	0.36	577	0.51	659	0.66	732	0.82	799	0.98
2438	505	0.43	597	0.59	676	0.75	748	0.92	813	1.09
2625	529	0.51	617	0.68	694	0.85	764	1.03	827	1.22
2813	554	0.60	638	0.78	713	0.97	781	1.16	843	1.35
3000	579	0.70	660	0.89	732	1.09	799	1.29	860	1.50
3188	604	0.81	683	1.02	753	1.23	817	1.44	877	1.65
3375	630	0.94	706	1.15	774	1.37	836	1.60	895	1.82
3563	657	1.08	729	1.31	795	1.54	856	1.77	913	2.01
3750	683	1.23	753	1.47	817	1.71	877	1.96	933	2.21

CFM	Available External Static Pressure (in. wg)									
	1.2		1.4		1.6		1.8		2.0	
	RPM	BHP	RPM	BHP	RPM	BHP	RPM	BHP	RPM	BHP
2250	860	1.14	917	1.31	971	1.48	1022	1.66	1071	1.84
2438	873	1.27	929	1.45	983	1.63	1033	1.81	1081	2.00
2625	887	1.40	942	1.59	995	1.78	1045	1.98	1092	2.18
2813	901	1.55	956	1.75	1008	1.95	1057	2.15	1104	2.36
3000	917	1.70	970	1.91	1021	2.13	1070	2.34	1117	2.56
3188	933	1.87	986	2.09	1036	2.32	1084	2.54	1130	2.77
3375	950	2.05	1002	2.29	1051	2.52	1098	2.76	1144	3.00
3563	967	2.25	1018	2.49	1067	2.74	1113	2.99	1158	3.24
3750	985	2.46	1035	2.71	1083	2.97	1129	3.23	1173	3.49

NOTE: For more information, see General Fan Performance Notes.

Boldface indicates field – supplied drive is required.

Standard static 518 – 733 RPM, 1.7 BHP max

Medium static 690 – 936 RPM, 2.4 BHP max

High static 838 – 1084 RPM, 3.7 BHP max

Table 34 – 50HC Size 08

3 Phase Non-HUMIDI-MIZER

7.5 Ton Horizontal Supply

CFM	Available External Static Pressure (in. wg)									
	0.2		0.4		0.6		0.8		1.0	
	RPM	BHP	RPM	BHP	RPM	BHP	RPM	BHP	RPM	BHP
2250	433	0.29	518	0.41	596	0.54	667	0.67	733	0.81
2438	454	0.35	535	0.48	609	0.61	677	0.75	741	0.90
2625	477	0.42	553	0.55	624	0.69	689	0.84	751	1.00
2813	500	0.49	572	0.64	640	0.78	703	0.94	763	1.10
3000	523	0.58	592	0.73	657	0.88	718	1.05	775	1.22
3188	547	0.68	613	0.83	675	1.00	733	1.17	789	1.34
3375	571	0.78	634	0.95	694	1.12	750	1.30	804	1.48
3563	596	0.90	656	1.07	713	1.25	768	1.44	820	1.63
3750	621	1.03	679	1.21	734	1.40	786	1.59	837	1.79

CFM	Available External Static Pressure (in. wg)									
	1.2		1.4		1.6		1.8		2.0	
	RPM	BHP	RPM	BHP	RPM	BHP	RPM	BHP	RPM	BHP
2250	795	0.96	854	1.11	910	1.27	963	1.43	1014	1.60
2438	802	1.05	859	1.21	913	1.38	966	1.55	1016	1.72
2625	810	1.16	865	1.32	919	1.49	970	1.67	1019	1.85
2813	819	1.27	874	1.44	925	1.62	975	1.80	1023	1.99
3000	830	1.39	883	1.57	934	1.76	982	1.95	1029	2.14
3188	843	1.53	894	1.71	943	1.90	990	2.10	1036	2.30
3375	856	1.67	905	1.86	953	2.06	1000	2.27	1045	2.48
3563	870	1.83	918	2.03	965	2.23	1010	2.44	1054	2.66
3750	885	1.99	932	2.20	978	2.42	1022	2.64	1065	2.86

NOTE: For more information, see General Fan Performance Notes.

Boldface indicates field – supplied drive is required.

Standard static 518 – 733 RPM, 1.7 BHP max

Medium static 690 – 936 RPM, 2.4 BHP max

High static 838 – 1084 RPM, 3.7 BHP max

50HC

APPENDIX III. FAN PERFORMANCE (cont.)

Table 35 – 50HC Size 09

3 Phase Non-HUMIDI-MIZER

8.5 Ton Vertical Supply

CFM	Available External Static Pressure (in. wg)									
	0.2		0.4		0.6		0.8		1.0	
	RPM	BHP	RPM	BHP	RPM	BHP	RPM	BHP	RPM	BHP
2550	495	0.43	570	0.56	634	0.70	693	0.83	746	0.96
2750	522	0.52	593	0.66	656	0.80	712	0.94	764	1.09
3000	556	0.65	623	0.80	684	0.95	738	1.11	789	1.26
3200	583	0.76	648	0.93	707	1.09	760	1.26	809	1.42
3400	611	0.89	674	1.07	730	1.24	782	1.42	831	1.59
3600	639	1.04	700	1.22	754	1.41	805	1.59	852	1.78
3850	675	1.24	733	1.44	785	1.64	834	1.83	880	2.03
4050	704	1.42	760	1.63	811	1.84	858	2.05	903	2.25
4250	733	1.62	787	1.84	836	2.06	883	2.28	926	2.49

CFM	Available External Static Pressure (in. wg)									
	1.2		1.4		1.6		1.8		2.0	
	RPM	BHP	RPM	BHP	RPM	BHP	RPM	BHP	RPM	BHP
2550	795	1.09	841	1.23	885	1.36	926	1.50	965	1.64
2750	813	1.23	858	1.37	901	1.52	942	1.66	981	1.81
3000	836	1.42	881	1.57	923	1.73	963	1.89	1001	2.05
3200	856	1.58	899	1.75	941	1.92	980	2.08	1018	2.25
3400	876	1.76	919	1.94	960	2.12	998	2.29	1036	2.47
3600	897	1.96	939	2.14	979	2.33	1017	2.52	1054	2.70
3850	923	2.23	964	2.42	1004	2.62	1041	2.82	1077	3.02
4050	945	2.46	986	2.67	1024	2.88	1061	3.08	1097	3.29
4250	968	2.71	1007	2.93	1045	3.15	1081	3.36	1117	3.58

NOTE: For more information, see General Fan Performance Notes.

Boldface indicates field – supplied drive is required.

- Standard static 518 – 733 RPM, 1.7 BHP max
- Medium static 690 – 936 RPM, 2.4 BHP max
- High static 838 – 1084 RPM, 3.7 BHP max

50HC

Table 36 – 50HC Size 09

3 Phase Non-HUMIDI-MIZER

8.5 Ton Horizontal Supply

CFM	Available External Static Pressure (in. wg)									
	0.2		0.4		0.6		0.8		1.0	
	RPM	BHP	RPM	BHP	RPM	BHP	RPM	BHP	RPM	BHP
2550	468	0.39	546	0.52	618	0.66	684	0.80	747	0.96
2750	492	0.47	566	0.61	634	0.75	698	0.91	759	1.07
3000	523	0.58	592	0.73	657	0.88	718	1.05	775	1.22
3200	549	0.68	614	0.84	676	1.00	735	1.17	790	1.35
3400	575	0.80	637	0.96	696	1.14	752	1.31	806	1.50
3600	601	0.93	661	1.10	717	1.28	771	1.47	823	1.66
3850	635	1.11	691	1.29	745	1.48	796	1.68	846	1.88
4050	662	1.27	716	1.46	767	1.66	817	1.87	865	2.08
4250	689	1.45	741	1.65	790	1.86	838	2.07	885	2.29

CFM	Available External Static Pressure (in. wg)									
	1.2		1.4		1.6		1.8		2.0	
	RPM	BHP	RPM	BHP	RPM	BHP	RPM	BHP	RPM	BHP
2550	806	1.11	863	1.28	916	1.45	968	1.62	1018	1.80
2750	816	1.23	871	1.40	923	1.58	973	1.76	1022	1.94
3000	830	1.39	883	1.57	934	1.76	982	1.95	1029	2.14
3200	843	1.53	894	1.72	944	1.91	991	2.11	1037	2.31
3400	858	1.69	907	1.88	955	2.09	1001	2.29	1046	2.50
3600	873	1.86	921	2.06	967	2.27	1012	2.48	1056	2.70
3850	894	2.09	940	2.30	985	2.52	1028	2.74	1071	2.97
4050	911	2.29	956	2.51	1000	2.74	1042	2.97	1083	3.20
4250	930	2.51	973	2.74	1015	2.97	1057	3.21	1097	3.45

NOTE: For more information, see General Fan Performance Notes.

Boldface indicates field – supplied drive is required.

- Standard static 518 – 733 RPM, 1.7 BHP max
- Medium static 690 – 936 RPM, 2.4 BHP max
- High static 838 – 1084 RPM, 3.7 BHP max

APPENDIX III. FAN PERFORMANCE (cont.)

Table 37 – 50HC Size 11

3 Phase Non-HUMIDI-MIZER

10 Ton Vertical Supply

CFM	Available External Static Pressure (in. wg)									
	0.2		0.4		0.6		0.8		1.0	
	RPM	BHP	RPM	BHP	RPM	BHP	RPM	BHP	RPM	BHP
3000	556	0.65	623	0.80	684	0.95	738	1.11	789	1.26
3250	590	0.79	655	0.96	713	1.13	766	1.29	815	1.46
3500	625	0.96	687	1.14	742	1.32	794	1.50	841	1.68
3750	661	1.16	719	1.35	773	1.54	822	1.73	869	1.93
4000	697	1.37	753	1.58	804	1.79	852	1.99	897	2.20
4250	733	1.62	787	1.84	836	2.06	883	2.28	926	2.49
4500	770	1.89	821	2.13	869	2.36	914	2.59	956	2.82
4750	807	2.20	856	2.45	902	2.69	945	2.94	986	3.18
5000	844	2.54	891	2.80	936	3.06	978	3.31	1018	3.57

CFM	Available External Static Pressure (in. wg)									
	1.2		1.4		1.6		1.8		2.0	
	RPM	BHP	RPM	BHP	RPM	BHP	RPM	BHP	RPM	BHP
3000	836	1.42	881	1.57	923	1.73	963	1.89	1001	2.05
3250	861	1.63	904	1.79	945	1.96	985	2.13	1023	2.30
3500	886	1.86	929	2.04	969	2.22	1008	2.40	1045	2.58
3750	912	2.12	954	2.31	994	2.50	1031	2.70	1068	2.89
4000	940	2.40	980	2.61	1019	2.81	1056	3.02	1092	3.22
4250	968	2.71	1007	2.93	1045	3.15	1081	3.36	1117	3.58
4500	996	3.05	1035	3.28	1072	3.51	1108	3.74	1142	3.97
4750	1026	3.42	1063	3.66	1100	3.91	1135	4.15	1168	4.39
5000	1056	3.82	1093	4.08	1128	4.34	1162	4.59	–	–

NOTE: For more information, see General Fan Performance Notes.

Boldface indicates field – supplied drive is required.

Standard static 518 – 733 RPM, 1.7 BHP max

Medium static 690 – 936 RPM, 2.4 BHP max

High static 838 – 1084 RPM, 3.7 BHP max

Table 38 – 50HC Size 11

3 Phase Non-HUMIDI-MIZER

10 Ton Horizontal Supply

CFM	Available External Static Pressure (in. wg)									
	0.2		0.4		0.6		0.8		1.0	
	RPM	BHP	RPM	BHP	RPM	BHP	RPM	BHP	RPM	BHP
3000	523	0.58	592	0.73	657	0.88	718	1.05	775	1.22
3250	555	0.71	620	0.87	681	1.04	739	1.21	794	1.39
3500	588	0.86	649	1.03	707	1.21	762	1.39	815	1.58
3750	621	1.03	679	1.21	734	1.40	786	1.59	837	1.79
4000	655	1.23	709	1.42	761	1.61	812	1.82	860	2.03
4250	689	1.45	741	1.65	790	1.86	838	2.07	885	2.29
4500	723	1.69	773	1.90	820	2.12	866	2.35	910	2.57
4750	758	1.96	805	2.19	850	2.42	894	2.65	937	2.89
5000	793	2.26	838	2.50	881	2.74	923	2.98	965	3.23

CFM	Available External Static Pressure (in. wg)									
	1.2		1.4		1.6		1.8		2.0	
	RPM	BHP	RPM	BHP	RPM	BHP	RPM	BHP	RPM	BHP
3000	830	1.39	883	1.57	934	1.76	982	1.95	1029	2.14
3250	847	1.57	897	1.76	946	1.96	993	2.16	1039	2.36
3500	865	1.77	914	1.97	961	2.18	1007	2.38	1051	2.60
3750	885	1.99	932	2.20	978	2.42	1022	2.64	1065	2.86
4000	907	2.24	952	2.46	996	2.68	1038	2.91	1080	3.14
4250	930	2.51	973	2.74	1015	2.97	1057	3.21	1097	3.45
4500	954	2.81	996	3.05	1037	3.29	1076	3.54	1115	3.79
4750	979	3.13	1019	3.38	1059	3.63	1097	3.89	1135	4.15
5000	1005	3.49	1044	3.74	1082	4.01	1119	4.27	1156	4.55

NOTE: For more information, see General Fan Performance Notes.

Boldface indicates field – supplied drive is required.

Standard static 591 – 838 RPM, 2.4 BHP max

Medium static 838 – 1084 RPM, 3.7 BHP max

High static 1022 – 1240 RPM, 4.9 BHP max

APPENDIX III. FAN PERFORMANCE (cont.)

Table 39 – 50HC Size 12

3 Phase Non-HUMIDI-MIZER

10 Ton Vertical Supply

CFM	Available External Static Pressure (in. wg)									
	0.2		0.4		0.6		0.8		1.0	
	RPM	BHP	RPM	BHP	RPM	BHP	RPM	BHP	RPM	BHP
3000	556	0.65	623	0.80	684	0.95	738	1.11	789	1.26
3250	590	0.79	655	0.96	713	1.13	766	1.29	815	1.46
3500	625	0.96	687	1.14	742	1.32	794	1.50	841	1.68
3750	661	1.16	719	1.35	773	1.54	822	1.73	869	1.93
4000	697	1.37	753	1.58	804	1.79	852	1.99	897	2.20
4250	733	1.62	787	1.84	836	2.06	883	2.28	926	2.49
4500	770	1.89	821	2.13	869	2.36	914	2.59	956	2.82
4750	807	2.20	856	2.45	902	2.69	945	2.94	986	3.18
5000	844	2.54	891	2.80	936	3.06	978	3.31	1018	3.57

CFM	Available External Static Pressure (in. wg)									
	1.2		1.4		1.6		1.8		2.0	
	RPM	BHP	RPM	BHP	RPM	BHP	RPM	BHP	RPM	BHP
3000	836	1.42	881	1.57	923	1.73	963	1.89	1001	2.05
3250	861	1.63	904	1.79	945	1.96	985	2.13	1023	2.30
3500	886	1.86	929	2.04	969	2.22	1008	2.40	1045	2.58
3750	912	2.12	954	2.31	994	2.50	1031	2.70	1068	2.89
4000	940	2.40	980	2.61	1019	2.81	1056	3.02	1092	3.22
4250	968	2.71	1007	2.93	1045	3.15	1081	3.36	1117	3.58
4500	996	3.05	1035	3.28	1072	3.51	1108	3.74	1142	3.97
4750	1026	3.42	1063	3.66	1100	3.91	1135	4.15	1168	4.39
5000	1056	3.82	1093	4.08	1128	4.34	1162	4.59	-	-

NOTE: For more information, see General Fan Performance Notes.

Boldface indicates field – supplied drive is required.

Standard static 591 – 838 RPM, 2.4 BHP max

Medium static 838 – 1084 RPM, 3.7 BHP max

High static 1022 – 1240 RPM, 4.9 BHP max

50HC

Table 40 – 50HC Size 12

3 Phase Non-HUMIDI-MIZER

10 Ton Horizontal Supply

CFM	Available External Static Pressure (in. wg)									
	0.2		0.4		0.6		0.8		1.0	
	RPM	BHP	RPM	BHP	RPM	BHP	RPM	BHP	RPM	BHP
3000	523	0.58	592	0.73	657	0.88	718	1.05	775	1.22
3250	555	0.71	620	0.87	681	1.04	739	1.21	794	1.39
3500	588	0.86	649	1.03	707	1.21	762	1.39	815	1.58
3750	621	1.03	679	1.21	734	1.40	786	1.59	837	1.79
4000	655	1.23	709	1.42	761	1.61	812	1.82	860	2.03
4250	689	1.45	741	1.65	790	1.86	838	2.07	885	2.29
4500	723	1.69	773	1.90	820	2.12	866	2.35	910	2.57
4750	758	1.96	805	2.19	850	2.42	894	2.65	937	2.89
5000	793	2.26	838	2.50	881	2.74	923	2.98	965	3.23

CFM	Available External Static Pressure (in. wg)									
	1.2		1.4		1.6		1.8		2.0	
	RPM	BHP	RPM	BHP	RPM	BHP	RPM	BHP	RPM	BHP
3000	830	1.39	883	1.57	934	1.76	982	1.95	1029	2.14
3250	847	1.57	897	1.76	946	1.96	993	2.16	1039	2.36
3500	865	1.77	914	1.97	961	2.18	1007	2.38	1051	2.60
3750	885	1.99	932	2.20	978	2.42	1022	2.64	1065	2.86
4000	907	2.24	952	2.46	996	2.68	1038	2.91	1080	3.14
4250	930	2.51	973	2.74	1015	2.97	1057	3.21	1097	3.45
4500	954	2.81	996	3.05	1037	3.29	1076	3.54	1115	3.79
4750	979	3.13	1019	3.38	1059	3.63	1097	3.89	1135	4.15
5000	1005	3.49	1044	3.74	1082	4.01	1119	4.27	1156	4.55

NOTE: For more information, see General Fan Performance Notes.

Boldface indicates field – supplied drive is required.

Standard static 591 – 838 RPM, 2.4 BHP max

Medium static 838 – 1084 RPM, 3.7 BHP max

High static 1022 – 1240 RPM, 4.9 BHP max

APPENDIX III. FAN PERFORMANCE (cont.)

Table 41 – 50HC Size 14

3 phase

12.5 Ton Vertical Supply

CFM	Available External Static Pressure (in. wg)									
	0.2		0.4		0.6		0.8		1.0	
	RPM	BHP	RPM	BHP	RPM	BHP	RPM	BHP	RPM	BHP
3438	383	0.46	458	0.66	530	0.91	601	1.20	668	1.53
3750	402	0.56	474	0.77	540	1.01	605	1.30	670	1.64
4063	422	0.67	491	0.90	552	1.14	613	1.43	674	1.76
4375	443	0.79	508	1.04	567	1.29	623	1.58	680	1.90
4688	464	0.93	527	1.19	583	1.46	636	1.75	689	2.07
5000	486	1.10	546	1.37	600	1.65	651	1.95	700	2.27
5313	509	1.28	565	1.56	618	1.86	666	2.17	713	2.49
5625	533	1.48	585	1.77	636	2.09	683	2.41	728	2.74
5938	557	1.71	605	2.01	655	2.34	701	2.67	744	3.02
6250	581	1.97	626	2.26	673	2.61	718	2.96	760	3.32

CFM	Available External Static Pressure (in. wg)									
	1.2		1.4		1.6		1.8		2.0	
	RPM	BHP	RPM	BHP	RPM	BHP	RPM	BHP	RPM	BHP
3438	729	1.88	783	2.25		2.62	879	2.99	921	3.37
3750	731	2.00	787	2.39	838	2.78	885	3.18	929	3.59
4063	733	2.13	789	2.52	841	2.94	890	3.36	935	3.79
4375	736	2.27	791	2.67	843	3.10	892	3.54	938	3.99
4688	741	2.43	794	2.83	845	3.26	894	3.72	941	4.19
5000	749	2.63	799	3.02	848	3.45	896	3.90	942	4.39
5313	760	2.85	806	3.23	853	3.66	899	4.11	944	4.60
5625	772	3.10	816	3.48	860	3.90	904	4.35	947	4.83
5938	786	3.38	827	3.76	869	4.18	911	4.62	952	5.09
6250	801	3.69	841	4.07	880	4.49	920	4.93	959	5.40

NOTE: For more information, see General Fan Performance Notes.

Boldface indicates field – supplied drive is required.

Standard static 440 – 609 RPM, 2.9 BHP max

Medium static 609 – 778 RPM, 3.7 BHP max

High static 776 – 955 RPM, 6.19 BHP max

Table 42 – 50HC Size 14

3 phase

12.5 Ton Horizontal Supply

CFM	Available External Static Pressure (in. wg)									
	0.2		0.4		0.6		0.8		1.0	
	RPM	BHP	RPM	BHP	RPM	BHP	RPM	BHP	RPM	BHP
3438	379	0.48	455	0.69	526	0.94	593	1.23	655	1.54
3750	399	0.59	469	0.80	536	1.06	600	1.35	660	1.67
4063	420	0.71	486	0.93	549	1.19	609	1.49	667	1.81
4375	442	0.84	503	1.08	562	1.35	620	1.65	675	1.97
4688	464	1.00	522	1.25	578	1.52	632	1.83	685	2.16
5000	486	1.17	541	1.44	594	1.72	646	2.03	696	2.37
5313	509	1.37	561	1.64	612	1.94	661	2.26	708	2.60
5625	532	1.58	582	1.87	630	2.18	677	2.51	722	2.86
5938	555	1.82	603	2.13	649	2.45	694	2.78	737	3.14
6250	578	2.09	625	2.41	669	2.74	711	3.09	753	3.45

CFM	Available External Static Pressure (in. wg)									
	1.2		1.4		1.6		1.8		2.0	
	RPM	BHP	RPM	BHP	RPM	BHP	RPM	BHP	RPM	BHP
3438	713	1.89	766	2.25	816	2.64	863	3.04	907	3.46
3750	717	2.02	770	2.39	820	2.79	867	3.20	911	3.63
4063	722	2.17	774	2.55	824	2.95	870	3.37	914	3.81
4375	728	2.33	779	2.72	828	3.13	874	3.56	918	4.00
4688	736	2.52	785	2.91	832	3.32	878	3.76	922	4.21
5000	745	2.73	792	3.12	838	3.54	883	3.98	926	4.44
5313	755	2.97	801	3.36	846	3.78	889	4.23	931	4.69
5625	767	3.23	811	3.63	854	4.05	896	4.50	937	4.97
5938	780	3.52	822	3.92	864	4.35	904	4.80	944	5.27
6250	794	3.84	835	4.25	875	4.68	914	5.13	952	5.61

NOTE: For more information, see General Fan Performance Notes.

Boldface indicates field – supplied drive is required.

Standard static 440 – 609 RPM, 2.9 BHP max

Medium static 609 – 778 RPM, 3.7 BHP max

High static 776 – 955 RPM, 6.19 BHP max

APPENDIX III. FAN PERFORMANCE (cont.)

X13 MULTI-SPEED/TORQUE MOTOR

Table 43 – 50HC*A04 Vertical Unit-Direct Drive

Speed (Torque) tap	CFM	ESP	BHP
1	900	0.36	0.16
	975	0.27	0.16
	1050	0.18	0.15
	1125	0.10	0.15
	1200	0.04	0.16
	1275	-	-
	1350	-	-
	1425	-	-
	1500	-	-
2	900	0.51	0.21
	975	0.40	0.20
	1050	0.30	0.19
	1125	0.21	0.18
	1200	0.11	0.17
	1275	0.02	0.16
	1350	-	-
	1425	-	-
	1500	-	-
3	900	0.84	0.33
	975	0.72	0.32
	1050	0.60	0.31
	1125	0.49	0.29
	1200	0.38	0.28
	1275	0.28	0.26
	1350	0.17	0.25
	1425	0.07	0.24
	1500	-	-
4	900	1.06	0.41
	975	0.96	0.41
	1050	0.86	0.41
	1125	0.74	0.40
	1200	0.63	0.38
	1275	0.50	0.37
	1350	0.38	0.35
	1425	0.26	0.34
	1500	0.15	0.32
5	900	1.24	0.51
	975	1.19	0.52
	1050	1.14	0.54
	1125	1.08	0.57
	1200	1.03	0.59
	1275	0.98	0.61
	1350	0.93	0.64
	1425	0.88	0.67
	1500	0.82	0.69

Table 44 – 50HC*A04 Horizontal Unit-Direct Drive

Speed (Torque) tap	CFM	ESP	BHP
1	900	0.47	0.21
	975	0.38	0.20
	1050	0.29	0.19
	1125	0.21	0.18
	1200	0.13	0.18
	1275	0.06	0.20
	1350	-	-
	1425	-	-
	1500	-	-
2	900	0.65	0.27
	975	0.54	0.26
	1050	0.44	0.25
	1125	0.33	0.24
	1200	0.23	0.23
	1275	0.13	0.21
	1350	0.02	0.20
	1425	-	-
	1500	-	-
3	900	0.96	0.38
	975	0.84	0.37
	1050	0.73	0.36
	1125	0.61	0.34
	1200	0.50	0.33
	1275	0.38	0.31
	1350	0.26	0.30
	1425	0.15	0.28
	1500	0.04	0.26
4	900	1.17	0.46
	975	1.08	0.46
	1050	0.98	0.46
	1125	0.87	0.45
	1200	0.75	0.44
	1275	0.63	0.42
	1350	0.51	0.40
	1425	0.39	0.39
	1500	0.27	0.37
5	900	1.35	0.52
	975	1.30	0.54
	1050	1.26	0.57
	1125	1.21	0.59
	1200	1.16	0.62
	1275	1.12	0.64
	1350	1.07	0.67
	1425	1.02	0.70
	1500	0.97	0.73

50HC

APPENDIX III. FAN PERFORMANCE (cont.)

X13 MULTI-SPEED/TORQUE MOTOR

Table 45 – 50HC*A05 Vertical Unit-Direct Drive

Speed (Torque) tap	CFM	ESP	BHP
1	1200	0.57	0.31
	1300	0.44	0.29
	1400	0.30	0.27
	1500	0.16	0.25
	1600	0.03	0.25
	1700	-	-
	1800	-	-
	1900	-	-
	2000	-	-
2	1200	0.68	0.35
	1300	0.54	0.33
	1400	0.40	0.31
	1500	0.24	0.28
	1600	0.10	0.26
	1700	-	-
	1800	-	-
	1900	-	-
	2000	-	-
3	1200	1.15	0.54
	1300	1.09	0.54
	1400	1.02	0.55
	1500	0.93	0.58
	1600	0.82	0.57
	1700	0.69	0.55
	1800	0.54	0.52
	1900	0.38	0.50
	2000	0.21	0.47
4	1200	1.16	0.56
	1300	1.12	0.59
	1400	1.07	0.61
	1500	1.00	0.65
	1600	0.92	0.65
	1700	0.80	0.66
	1800	0.67	0.65
	1900	0.51	0.62
	2000	0.34	0.59
5	1200	1.16	0.59
	1300	1.11	0.63
	1400	1.00	0.67
	1500	0.88	0.67
	1600	0.96	0.75
	1700	0.91	0.75
	1800	0.86	0.83
	1900	0.80	0.87
	2000	0.74	0.91

Table 46 – 50HC*A05Horizontal Unit-Direct Drive

Speed (Torque) tap	CFM	ESP	BHP
1	1200	0.62	0.34
	1300	0.48	0.32
	1400	0.35	0.30
	1500	0.23	0.28
	1600	0.12	0.28
	1700	0.02	0.27
	1800	-	-
	1900	-	-
	2000	-	-
2	1200	0.74	0.39
	1300	0.60	0.37
	1400	0.46	0.35
	1500	0.32	0.32
	1600	0.19	0.30
	1700	0.07	0.27
	1800	-	-
	1900	-	-
	2000	-	-
3	1200	1.20	0.59
	1300	1.12	0.60
	1400	1.01	0.61
	1500	0.89	0.62
	1600	0.76	0.59
	1700	0.61	0.56
	1800	0.47	0.53
	1900	0.32	0.50
	2000	0.18	0.47
4	1200	1.24	0.60
	1300	1.18	0.63
	1400	1.11	0.65
	1500	1.03	0.69
	1600	0.93	0.69
	1700	0.82	0.69
	1800	0.70	0.69
	1900	0.56	0.66
	2000	0.41	0.63
5	1200	1.25	0.61
	1300	1.20	0.65
	1400	1.11	0.68
	1500	1.03	0.68
	1600	1.05	0.76
	1700	1.01	0.76
	1800	0.96	0.84
	1900	0.91	0.89
	2000	0.87	0.93

50HC

APPENDIX III. FAN PERFORMANCE (cont.)

X13 MULTI-SPEED/TORQUE MOTOR

Table 47 – 50HC*A06 Vertical Unit-Direct Drive

Speed (Torque) tap	CFM	ESP	BHP
1	1500	0.50	0.44
	1625	0.32	0.42
	1750	0.14	0.39
	1875	-	-
	2000	-	-
	2125	-	-
	2250	-	-
	2375	-	-
	2500	-	-
2	1500	0.72	0.56
	1625	0.53	0.53
	1750	0.34	0.50
	1875	0.18	0.48
	2000	-	-
	2125	-	-
	2250	-	-
	2375	-	-
	2500	-	-
3	1500	1.20	0.84
	1625	1.02	0.82
	1750	0.82	0.82
	1875	0.61	0.79
	2000	0.40	0.75
	2125	0.20	0.71
	2250	0.04	0.67
	2375	-	-
	2500	-	-
4	1500	1.31	0.92
	1625	1.17	0.92
	1750	0.99	0.95
	1875	0.80	0.94
	2000	0.59	0.90
	2125	0.37	0.86
	2250	0.17	0.83
	2375	0.00	0.79
	2500	-	-
5	1500	1.36	0.94
	1625	1.24	0.99
	1750	0.99	1.02
	1875	0.80	1.05
	2000	0.74	1.03
	2125	0.53	0.99
	2250	0.31	0.94
	2375	0.08	0.90
	2500	-	0.86

Table 48 – 50HC*A06 Horizontal Unit-Direct Drive

Speed (Torque) tap	CFM	ESP	BHP
1	1500	0.63	0.49
	1625	0.45	0.46
	1750	0.27	0.43
	1875	0.10	0.39
	2000	-	-
	2125	-	-
	2250	-	-
	2375	-	-
	2500	-	-
2	1500	0.88	0.61
	1625	0.69	0.58
	1750	0.49	0.55
	1875	0.30	0.51
	2000	0.12	0.48
	2125	-	-
	2250	-	-
	2375	-	-
	2500	-	-
3	1500	1.37	0.89
	1625	1.20	0.87
	1750	1.02	0.86
	1875	0.81	0.83
	2000	0.60	0.79
	2125	0.39	0.75
	2250	0.21	0.71
	2375	0.07	0.67
	2500	-	-
4	1500	1.48	0.95
	1625	1.35	0.95
	1750	1.20	0.99
	1875	1.03	0.99
	2000	0.83	0.96
	2125	0.63	0.93
	2250	0.42	0.89
	2375	0.22	0.84
	2500	0.05	0.78
5	1500	1.52	0.97
	1625	1.42	1.01
	1750	1.20	1.05
	1875	1.03	1.09
	2000	1.00	1.09
	2125	0.82	1.06
	2250	0.62	1.02
	2375	0.40	0.98
	2500	0.16	0.93

50HC

APPENDIX III. FAN PERFORMANCE (cont.)

X13 MULTI-SPEED/TORQUE MOTOR

Table 49 – Pulley Adjustment

UNIT		Motor/Drive Combo	Motor Pulley turns open										
			0	0.5	1	1.5	2	2.5	3	3.5	4	4.5	5
04	1 Phase	Standard Static	854	825	795	766	736	707	678	648	619	589	560
		Medium Static	1175	1135	1094	1054	1013	973	932	892	851	811	770
	3 Phase	Standard Static*	854	825	795	766	736	707	678	648	619	589	560
		Medium Static*	1175	1135	1094	1054	1013	973	932	892	851	811	770
		High Static	1466	1423	1380	1337	1294	1251	1207	1164	1121	1078	1035
		Standard Static	854	825	795	766	736	707	678	648	619	589	560
05	1 Phase	Standard Static	854	825	795	766	736	707	678	648	619	589	560
		Medium Static	1175	1135	1094	1054	1013	973	932	892	851	811	770
	3 Phase	Standard Static*	854	825	795	766	736	707	678	648	619	589	560
		Medium Static*	1175	1135	1094	1054	1013	973	932	892	851	811	770
		Medium Static	1303	1265	1226	1188	1150	1112	1073	1035	997	958	920
		High Static	1550	1516	1482	1447	1413	1379	1345	1311	1276	1242	1208
06	1 Phase	Standard Static	1175	1135	1094	1054	1013	973	932	892	851	811	770
		Medium Static	1466	1423	1380	1337	1294	1251	1207	1164	1121	1078	1035
	3 Phase	Standard Static*	1175	1135	1094	1054	1013	973	932	892	851	811	770
		Medium Static*	1466	1423	1380	1337	1294	1251	1207	1164	1121	1078	1035
		High Static	1550	1525	1501	1476	1451	1427	1402	1377	1352	1328	1303
		Standard Static	1175	1135	1094	1054	1013	973	932	892	851	811	770
07	3 Phase	Standard Static	747	721	695	670	644	618	592	566	541	515	489
		Medium Static	949	927	906	884	863	841	819	798	776	755	733
		High Static	1102	1083	1063	1044	1025	1006	986	967	948	928	909
08	3 Phase	Standard Static	733	712	690	669	647	626	604	583	561	540	518
		Medium Static	936	911	887	862	838	813	788	764	739	715	690
		High Static	1084	1059	1035	1010	986	961	936	912	887	863	838
09	3 Phase	Standard Static	733	712	690	669	647	626	604	583	561	540	518
		Medium Static	936	911	887	862	838	813	788	764	739	715	690
		High Static	1084	1059	1035	1010	986	961	936	912	887	863	838
11	3 Phase	Standard Static	838	813	789	764	739	715	690	665	640	616	591
		Medium Static	1084	1059	1035	1010	986	961	936	912	887	863	838
		High Static	1240	1218	1196	1175	1153	1131	1109	1087	1066	1044	1022
12	3 Phase	Standard Static	838	813	789	764	739	715	690	665	640	616	591
		Medium Static	1084	1059	1035	1010	986	961	936	912	887	863	838
		High Static	1240	1218	1196	1175	1153	1131	1109	1087	1066	1044	1022
14	3 Phase	Standard Static	843	824	805	786	767	748	728	709	690	671	652
		Medium Static	778	761	744	727	710	694	677	660	643	626	609
		High Static	955	937	919	901	883	866	848	830	812	794	776

■ – Factory settings

* Humidi–MiZer models only

50HC

APPENDIX IV. WIRING DIAGRAMS

Table 50 – Wiring Diagrams

50HC*A04-D14 UNITS					
		STANDARD		HUMIDI-MIZER™	
SIZE	VOLTAGE	CONTROL	POWER	CONTROL	POWER
A04 – A06	230 – 1 – 60	48TM502410 – H	48TM502523 – G	48TM503087 – K	48TM503090 – I
	208/230 – 3 – 60		48TM502524 – I		48TM503097 – J
	460 – 3 – 60				48TM503131 – K
	575 – 3 – 60				
A07	208/230 – 3 – 60	48TM500928 – S	48TM500737 – T	48TM503176 – K	48TM503179 – F
	460 – 3 – 60				48TM503300 – J
	575 – 3 – 60				
D08 – D09	208/230 – 3 – 60	48TM501323 – Q	48TM501324 – Q	48TM503246 – L	48TM503247 – E
	460 – 3 – 60				48TM503248 – G
	575 – 3 – 60				
D11	208/230 – 3 – 60	48TM504180 – J	48TM504183 – H	48TM504728 – D	48TM504183 – H
	460 – 3 – 60		48TM504551 – D		48TM504551 – D
	575 – 3 – 60				
D12	208/230 – 3 – 60	48TM501247 – R	48TM501248 – O	48TM503249 – L	48TM503250 – F
	460 – 3 – 60				
	575 – 3 – 60				
D14	208/230 – 3 – 60	50TM501064 – K	50TM501159 – F	50TM501503 – I	50TM501506 – G
	460 – 3 – 60		50TM501160 – E		50TM501505 – G
	575 – 3 – 60				50TM501511 – G
A04 – A06	PremierLink*	48TM500983 – L		48TM500983 – L	
A07 – D14	PremierLink*	48TM504587		48TM504587	
A04 – A06	RTU – Open*	48TM502741 – C		48TM502741 – C	
A07 – D14	RTU – Open*	48TM503310 – C		48TM503310 – C	

50HC

APPENDIX IV. WIRING DIAGRAMS

50HC

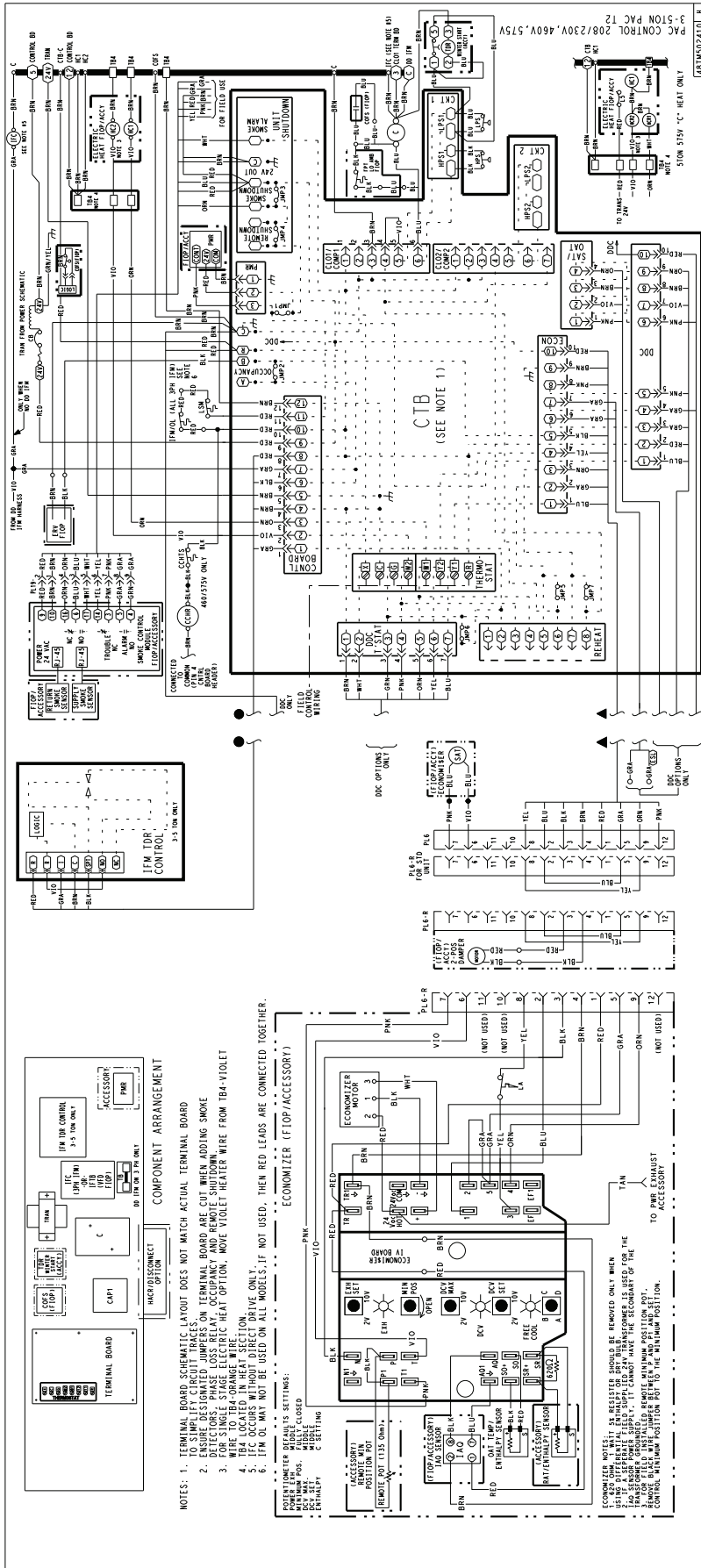
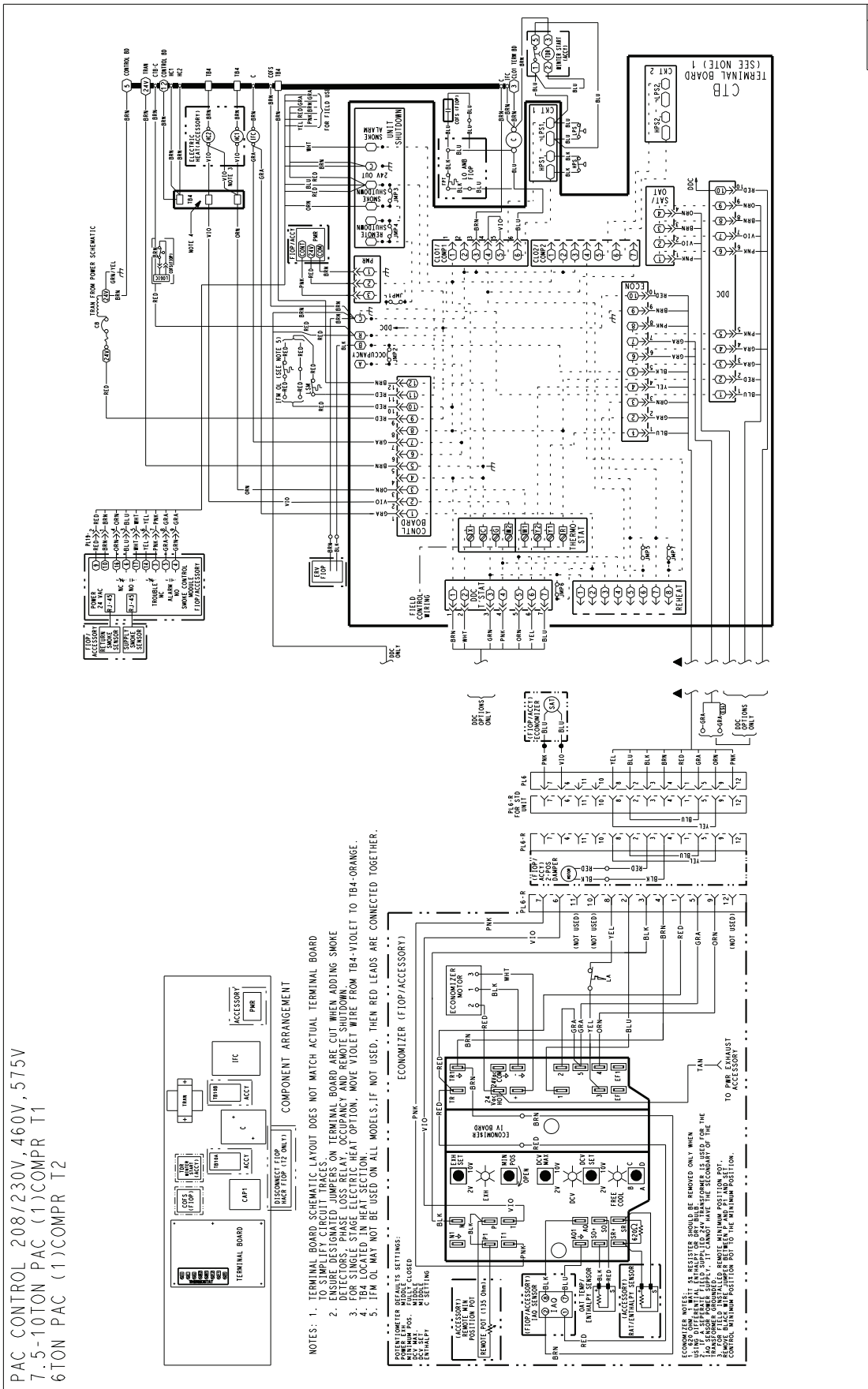

Fig. 58 - 50HC *A04-A06 PAC Control Diagram - 208-1-60; 208/230-3-60; 460/575-3-60

APPENDIX IV. WIRING DIAGRAMS



50HC

Fig. 59 - 50HC*A07 PAC Control Diagram - 208/230-3-60; 460/575-3-60

APPENDIX IV. WIRING DIAGRAMS

50HC

PAC CONTROL 208/230V, 460V, 575V DUAL COMPRESSOR
 7.5-10TON PAC (2)COMPR T1
 7.5-8.5TON PAC (2)COMPR T2

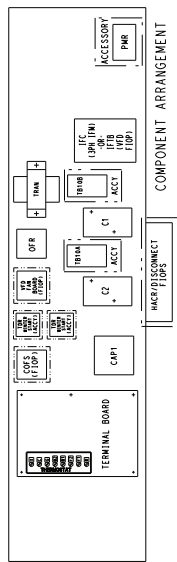

COMPONENT ARRANGEMENT

- NOTES: 1. TERMINAL BOARD SCHEMATIC LAYOUT DOES NOT MATCH ACTUAL TERMINAL BOARD TO SIMPLIFY WIRING. WIRING ON TERMINAL BOARD ARE CUT WHEN ADDING SMOKE DETECTORS, PHASE LOSS RELAY, OCCUPANCY AND REMOTE SHUTDOWN. UNIT 2. FOR SINGLE STAGE ELECTRIC HEAT OPTION, MOVE VIOLET WIRE FROM TB4-VIOLET TO TB4-ORANGE 3. IFM OL MAY NOT BE USED ON ALL MODELS. IF NOT USED, THEN RED LEADS ARE CONNECTED TOGETHER.

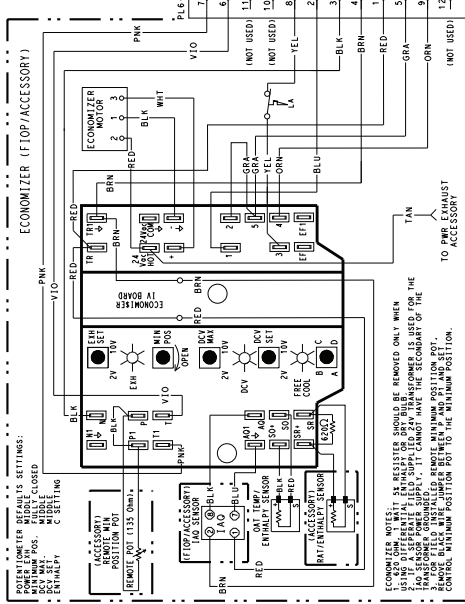

ECONOMIZER NOTES: 1. 5K RESISTOR SHOULD BE REMOVED ONLY WHEN USING DIFFERENTIAL THERMISTAT OR OPTIMIZER. 2. IFM OL SENSOR POWER SUPPLY, IT CANNOT HAVE THE SECONDARY OF THE REMOTE RELAY WIRE USED IN THE REMOTE POSITION. 3. REMOTE RELAY WIRE USED IN THE REMOTE POSITION MUST BE CONTROL WIREMINOR POSITION POT TO THE MINIMUM POSITION.

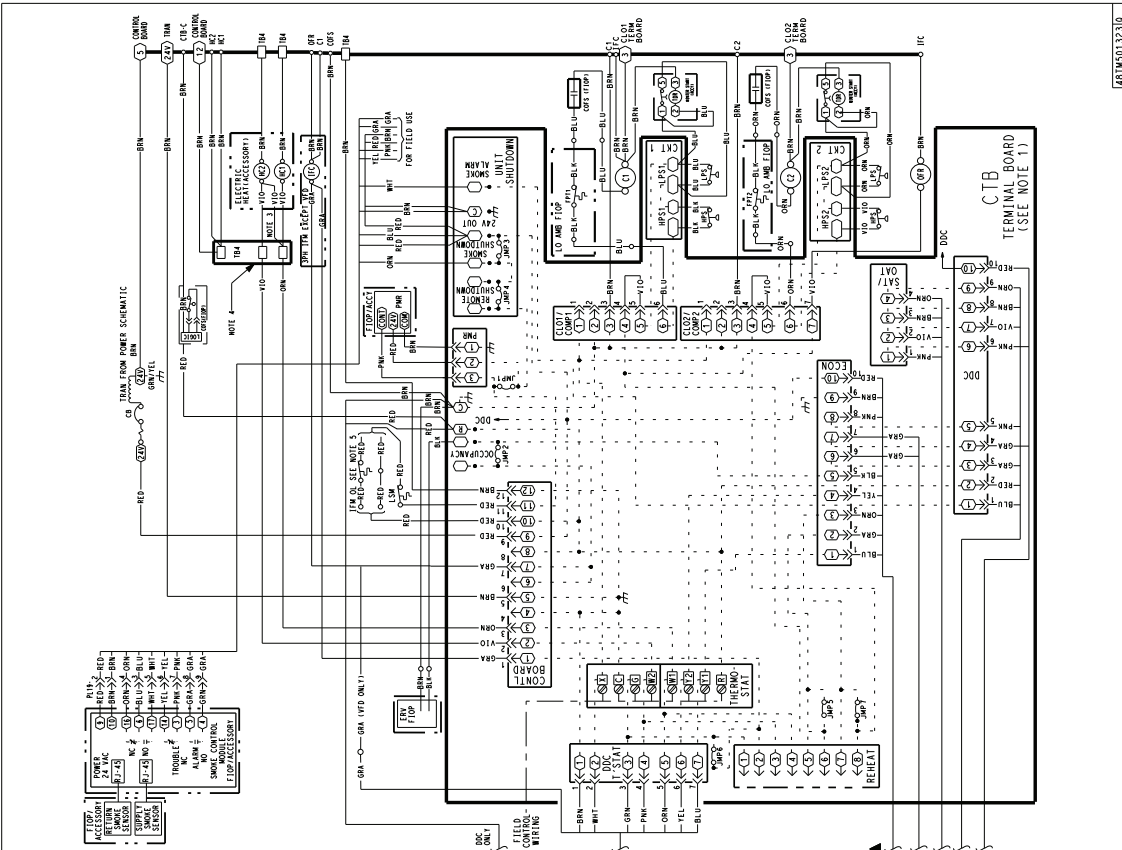

461M50132310

Fig. 60 - 50HC*D08-D09 PAC Control Diagram - 208/230-3-60; 460/575-3-60

APPENDIX IV. WIRING DIAGRAMS

50HC

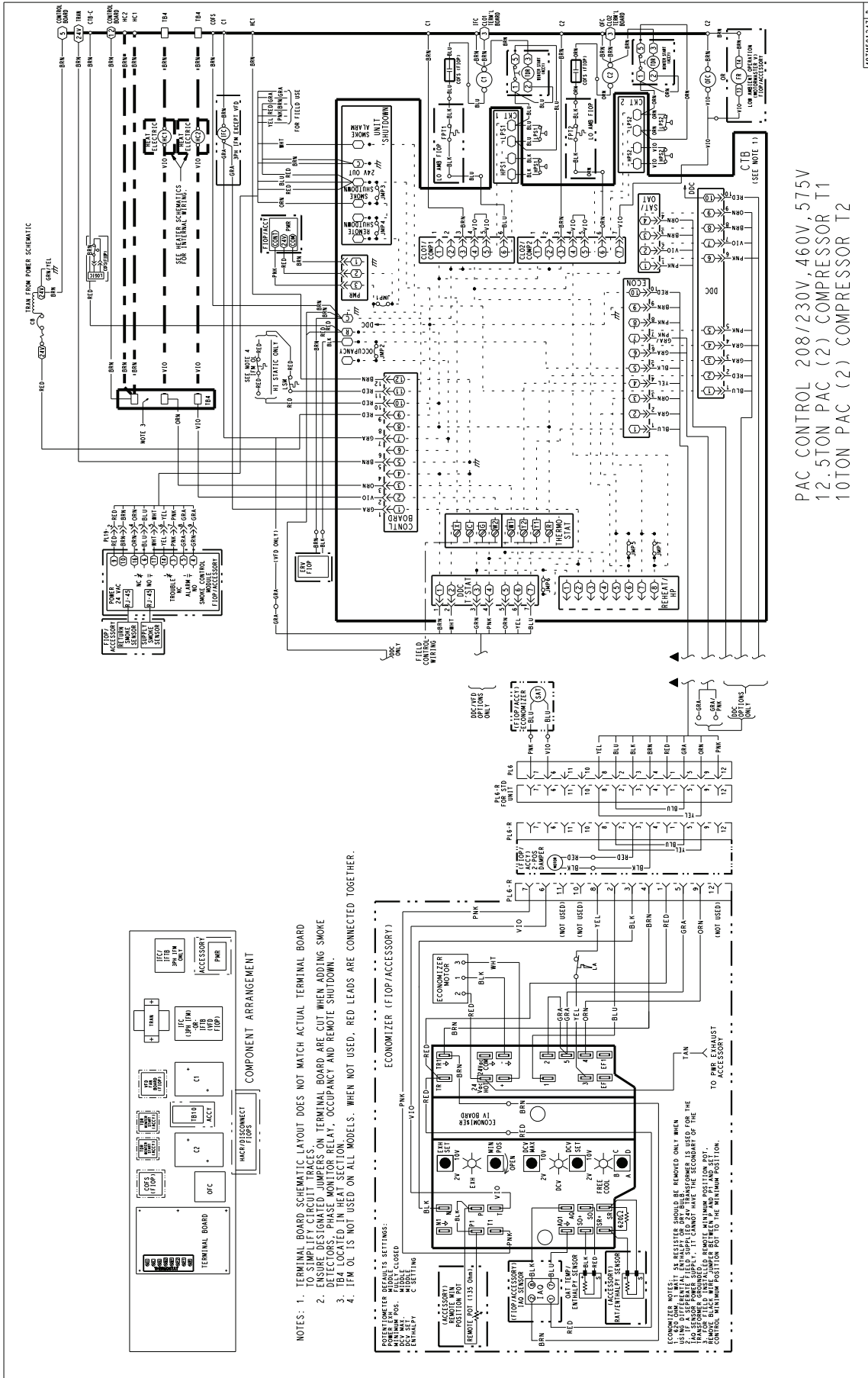

Fig. 62 - 50HC*D12 PAC Control Diagram - 208/230-3-60; 460/575-3-60

APPENDIX IV. WIRING DIAGRAMS

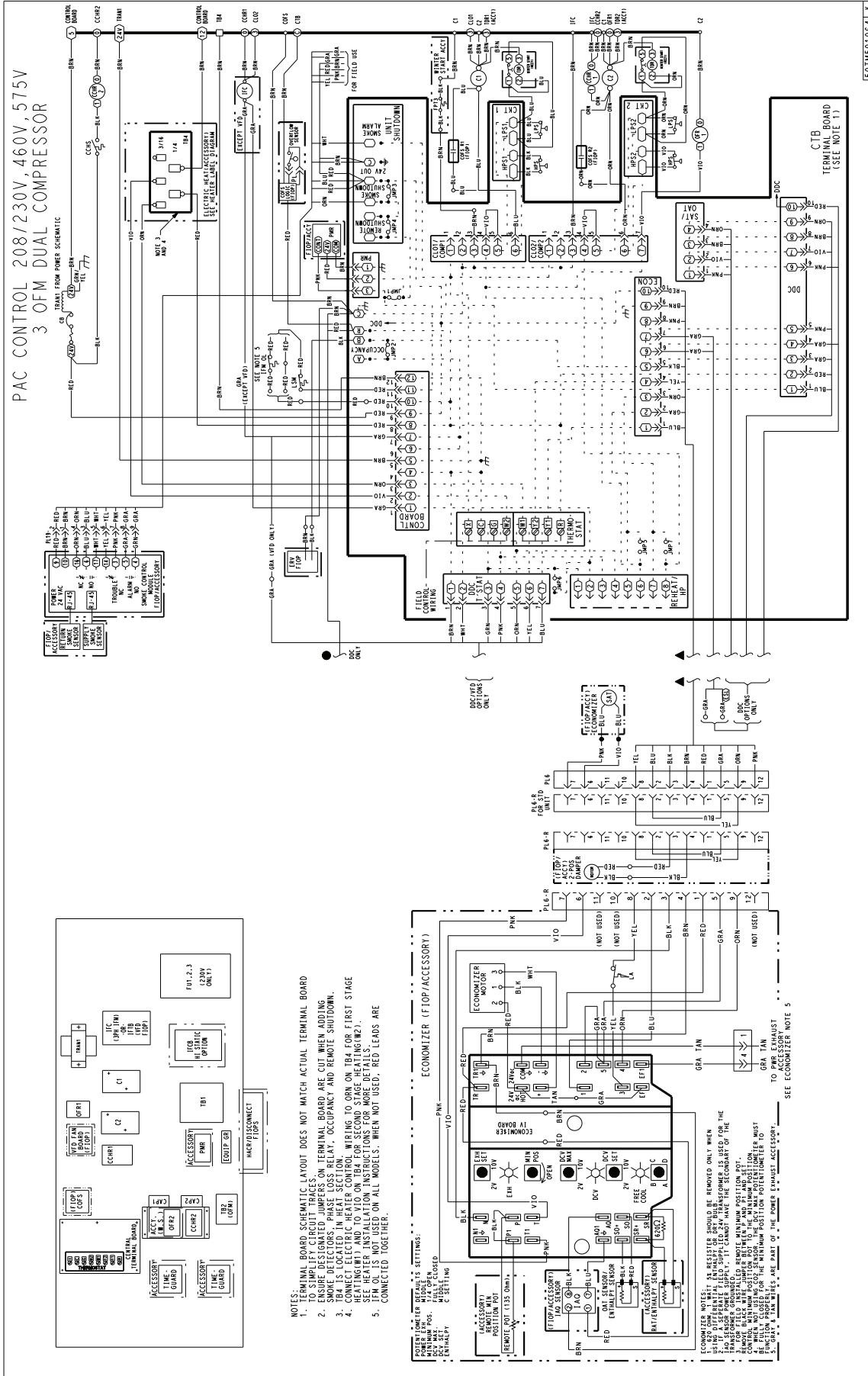

Fig. 63 - 50HC*D14 PAC Control Diagram - 208/230-3-60; 460/575-3-60

50HC

APPENDIX IV. WIRING DIAGRAMS

PAC POWER 208/230-1-60
3-5TON PAC T2

50HC

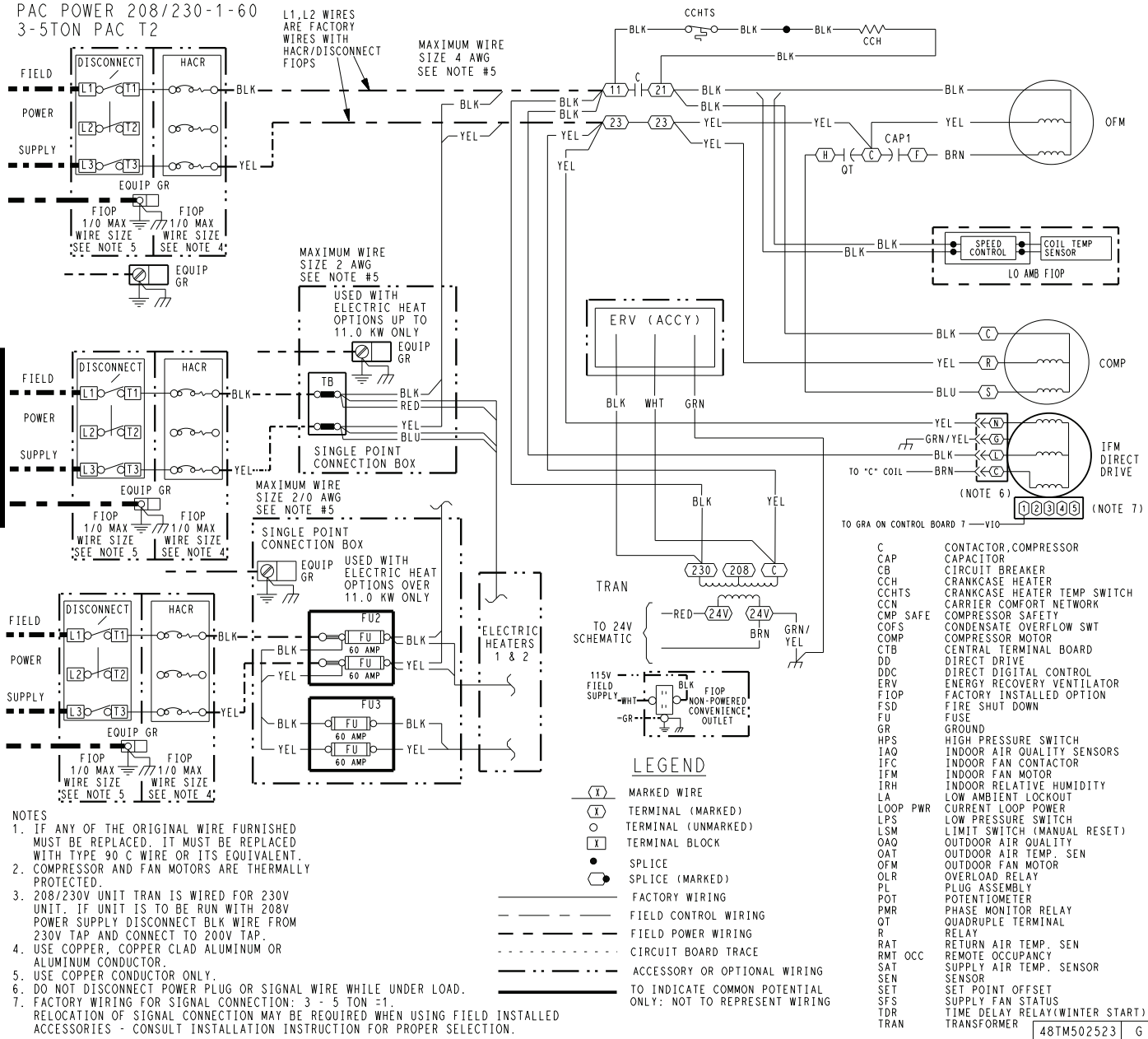

Fig. 64 - 50HC*A04-A06 PAC Power Diagram - 230-1-60

A160141

APPENDIX IV. WIRING DIAGRAMS

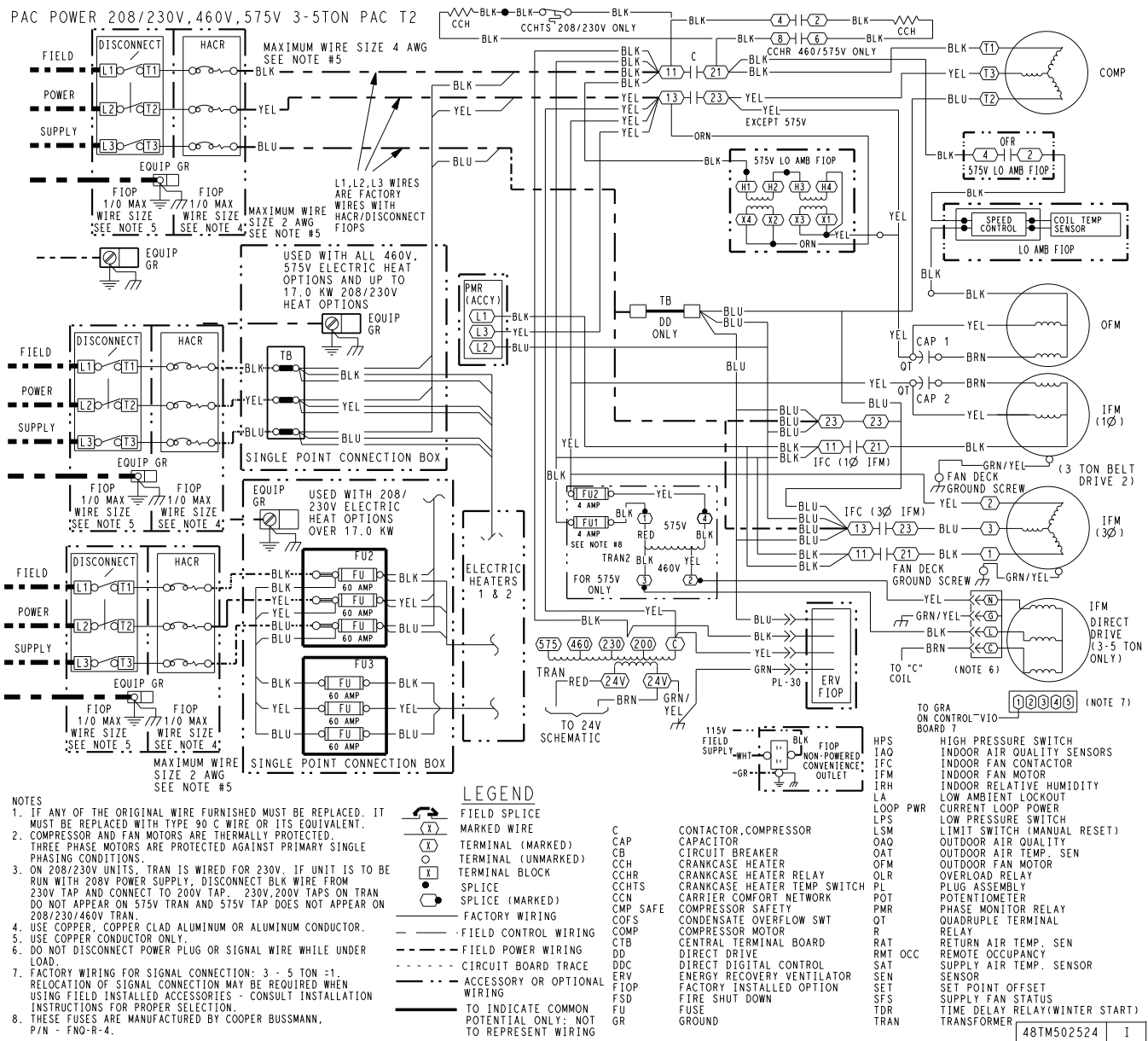

Fig. 65 - 50HC*A04-A06 PAC Power Diagram - 208/230-3-60; 460-3-60

A160142

APPENDIX IV. WIRING DIAGRAMS

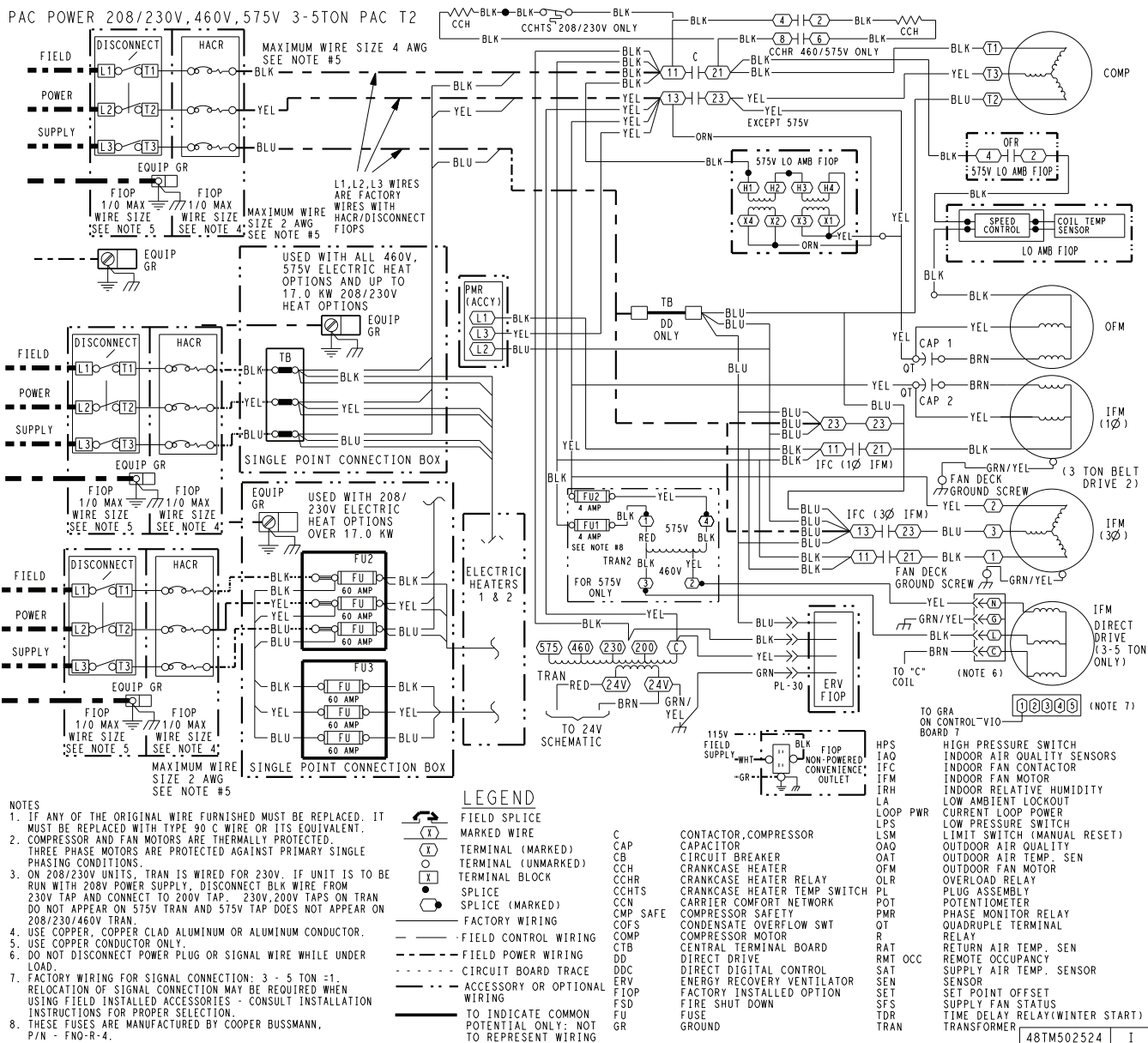

Fig. 66 - 50HC* A04-A06 PAC Power Diagram - 575-3-60

APPENDIX IV. WIRING DIAGRAMS

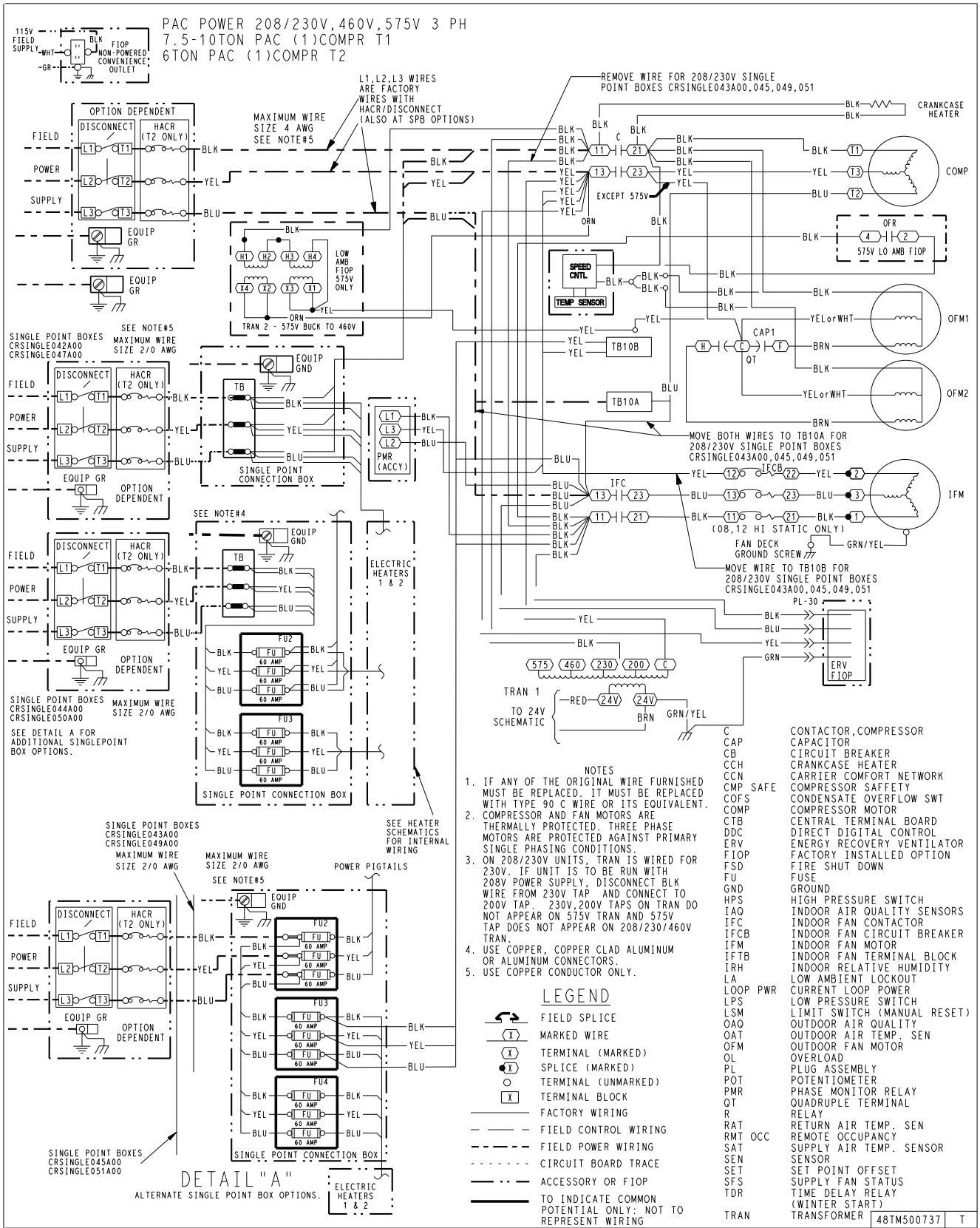

Fig. 67 - 50HC*A07-A12 PAC Power Diagram - 208/230-3-60, 460-3-60

50HC

A160143

APPENDIX IV. WIRING DIAGRAMS

50HC

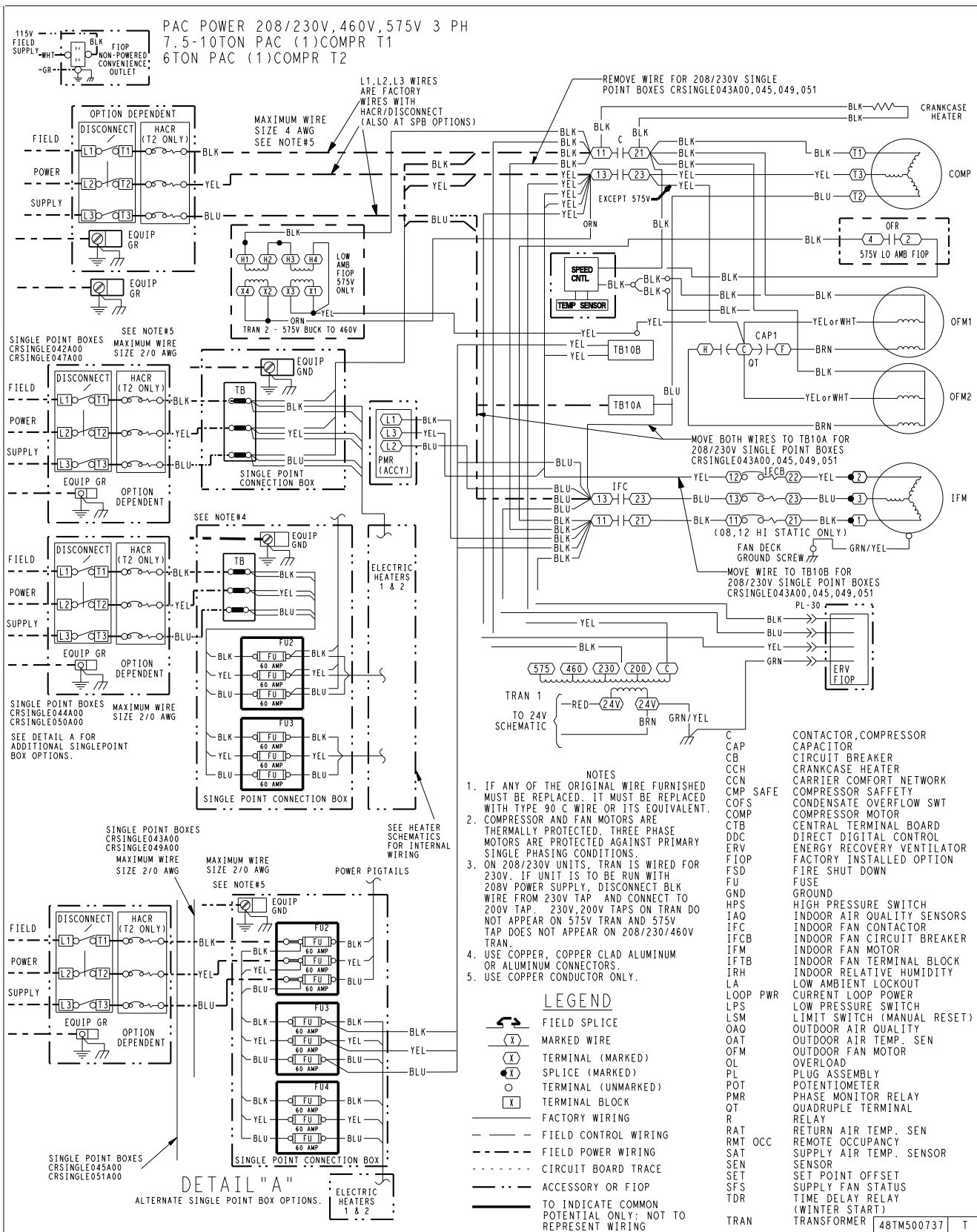
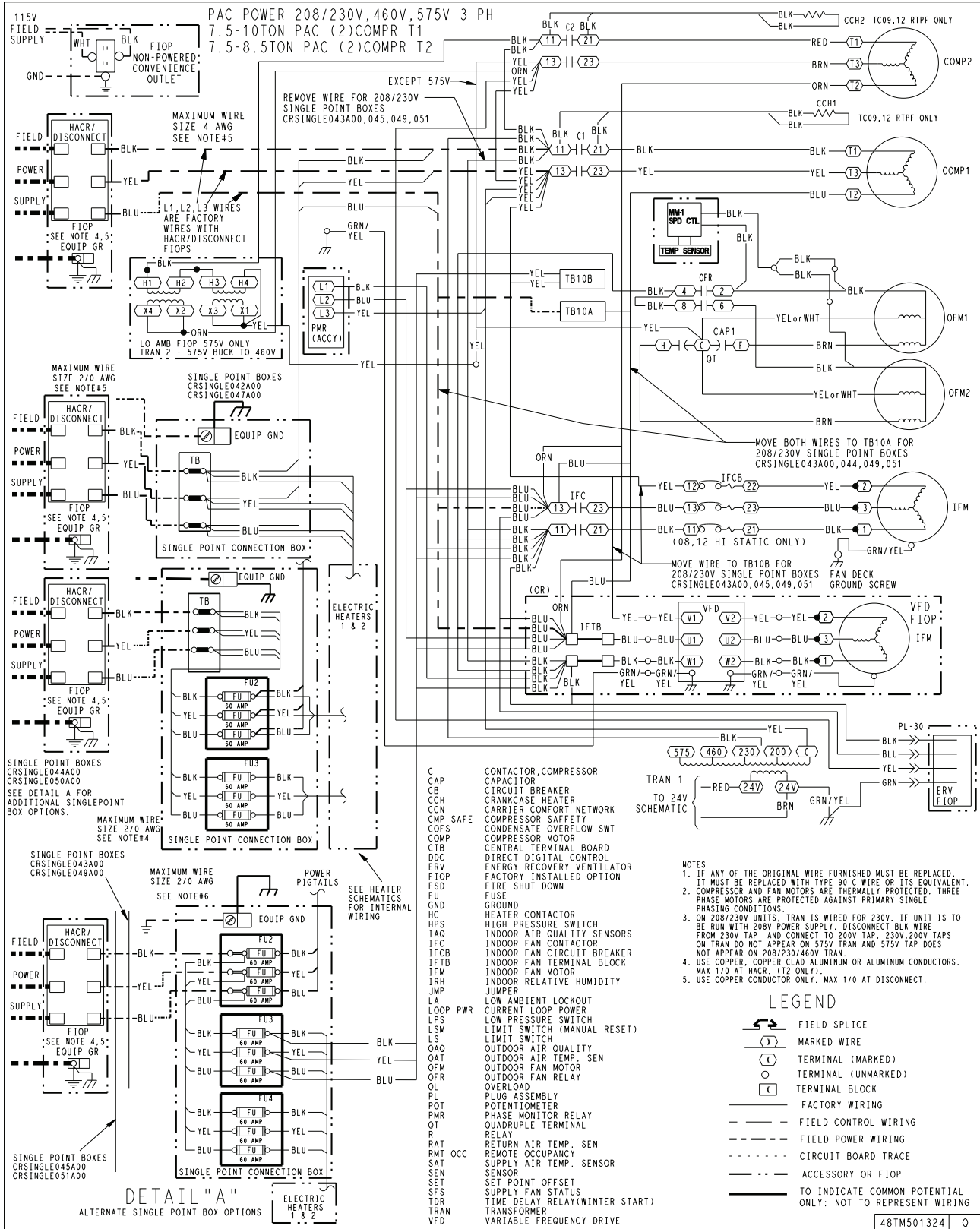

Fig. 68 - 50HC*A07-A12 PAC Power Diagram - 575-3-60

A160143

APPENDIX IV. WIRING DIAGRAMS



50HC

Fig. 69 - 50HC*D08-D09 PAC Power Diagram - 230/460-3-60

A160144

APPENDIX IV. WIRING DIAGRAMS

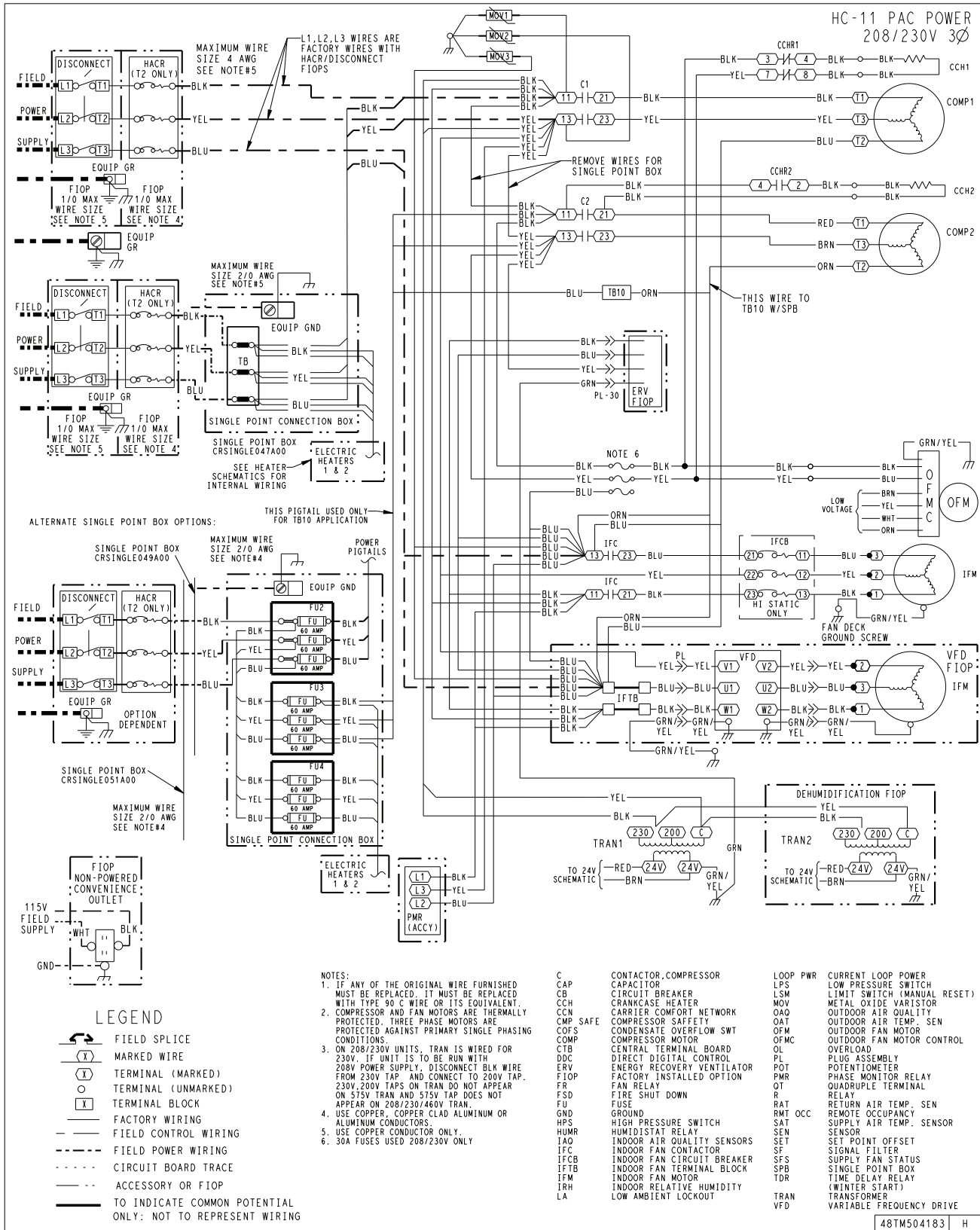

50HC

Fig. 71 - 50HC* D11 PAC Power Diagram 208/230-3-60

A160146

APPENDIX IV. WIRING DIAGRAMS

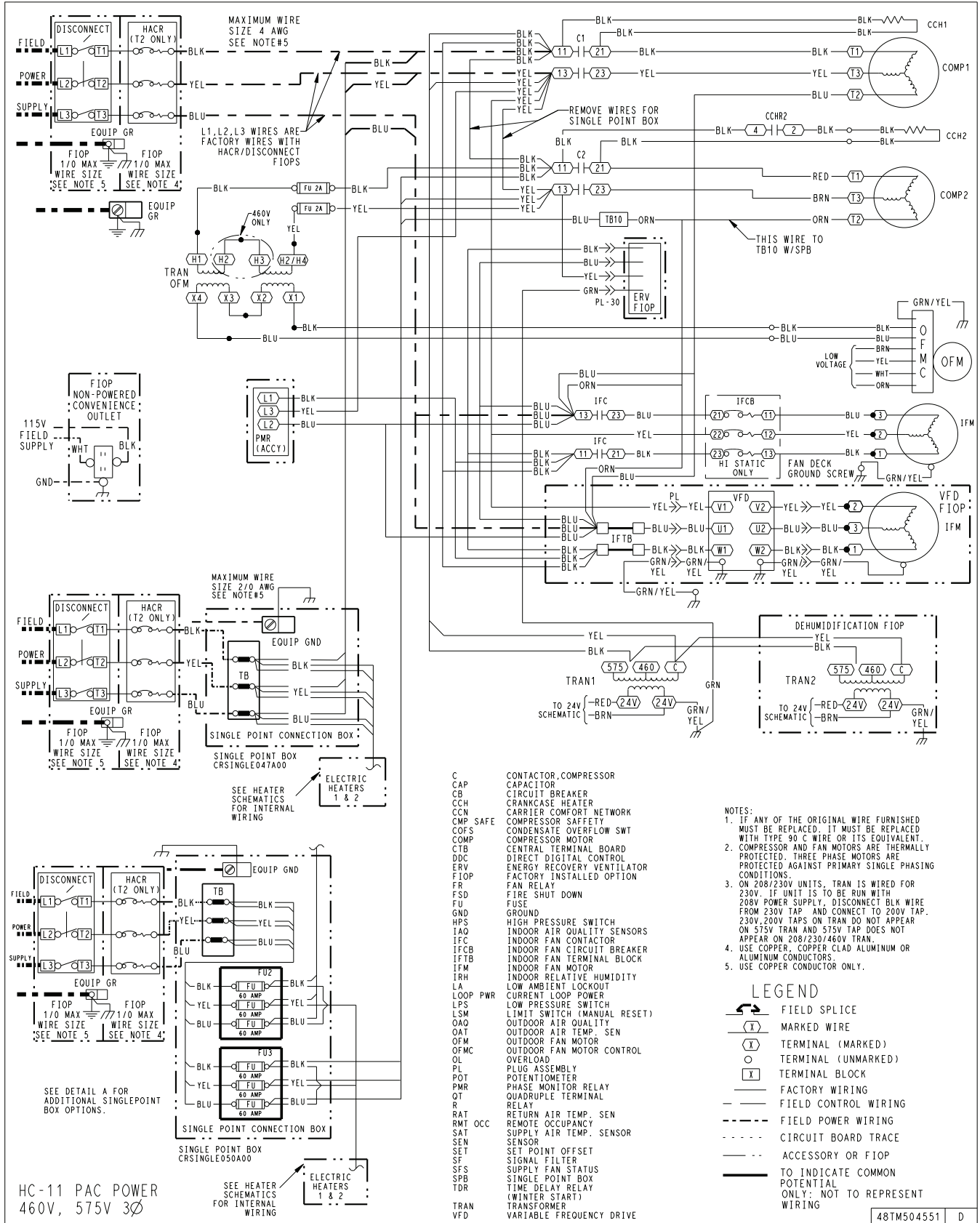
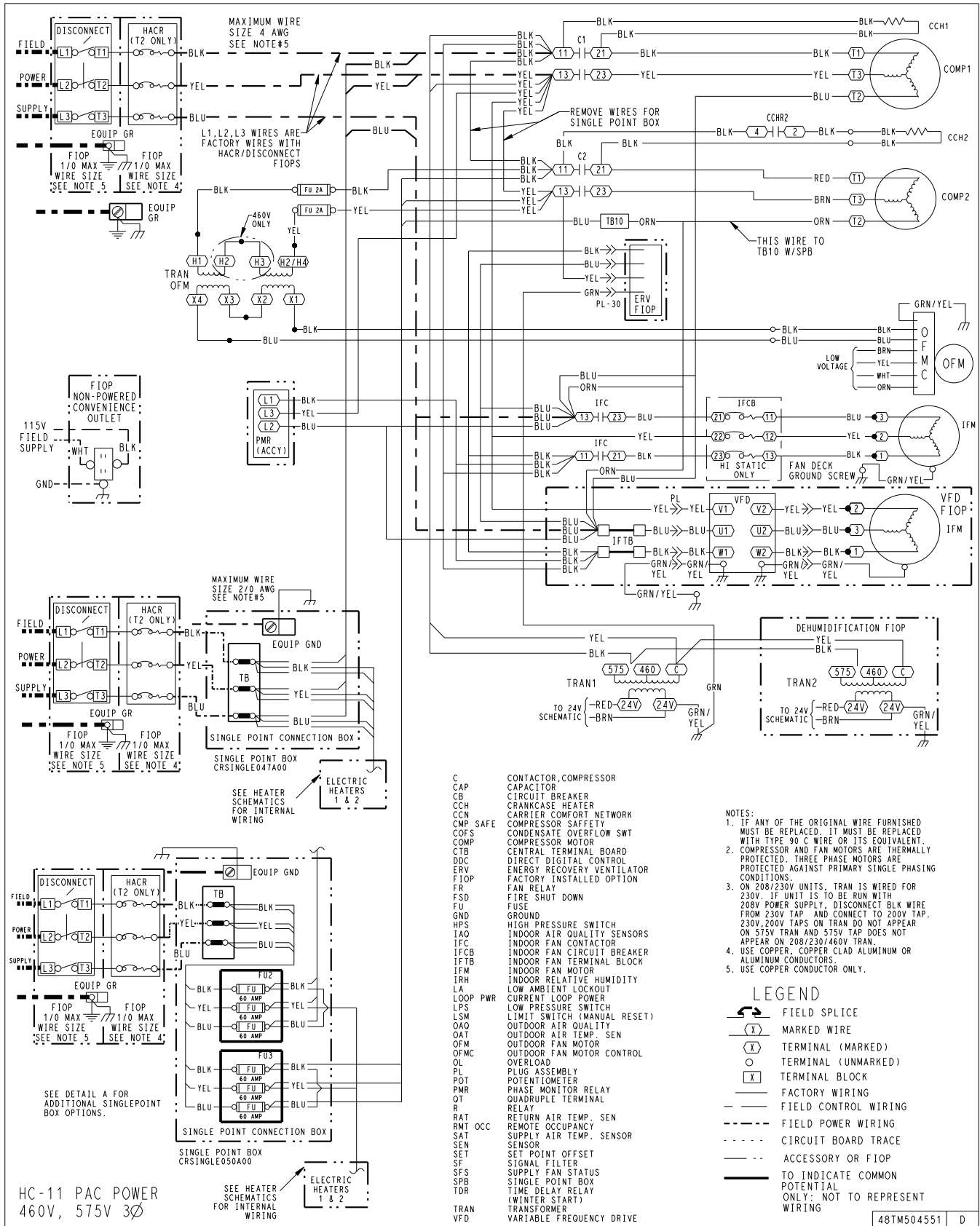

Fig. 72 - 50HC*D11 PAC Power Diagram 460-3-60

A160147

APPENDIX IV. WIRING DIAGRAMS



50HC

Fig. 73 - 50HC*D11 PAC Power Diagram 575-3-60

A160147

APPENDIX IV. WIRING DIAGRAMS

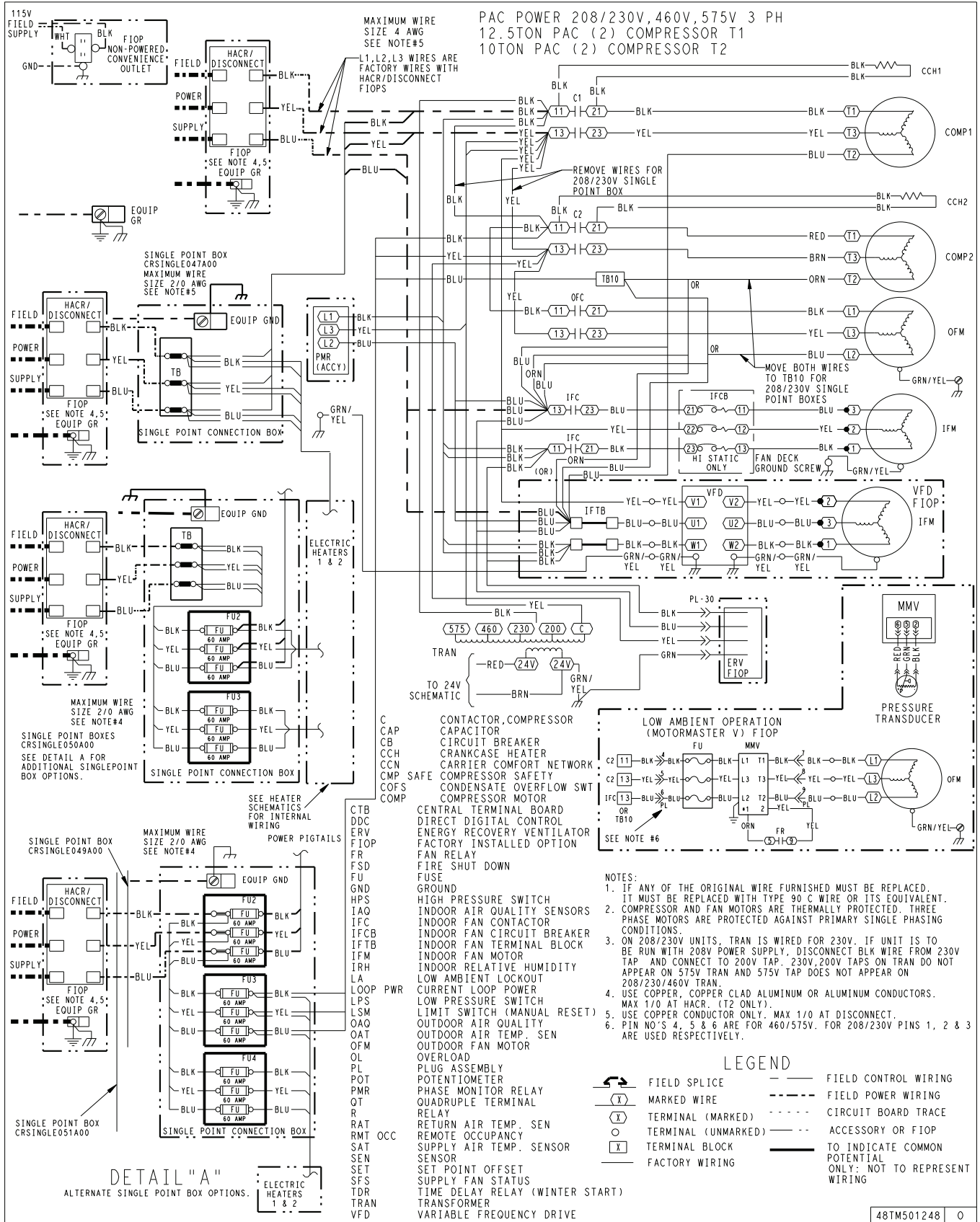
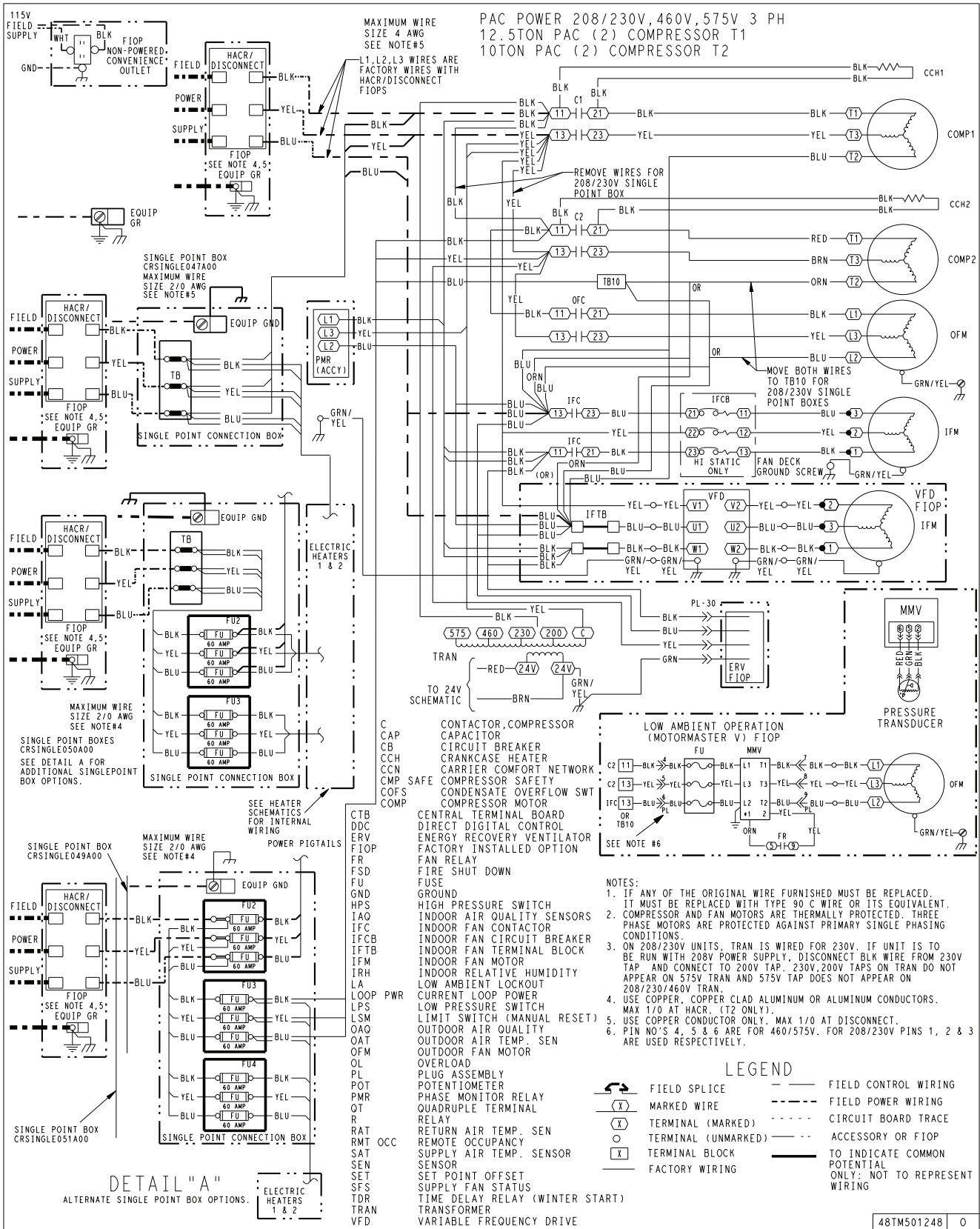

Fig. 74 - 50HC*D12 PAC Power Diagram - 230/460-3-60

48TM501248 0

A160145

APPENDIX IV. WIRING DIAGRAMS



50HC

Fig. 75 - 50HC*D12 PAC Power Diagram - 575-3-60

A160145

APPENDIX IV. WIRING DIAGRAMS

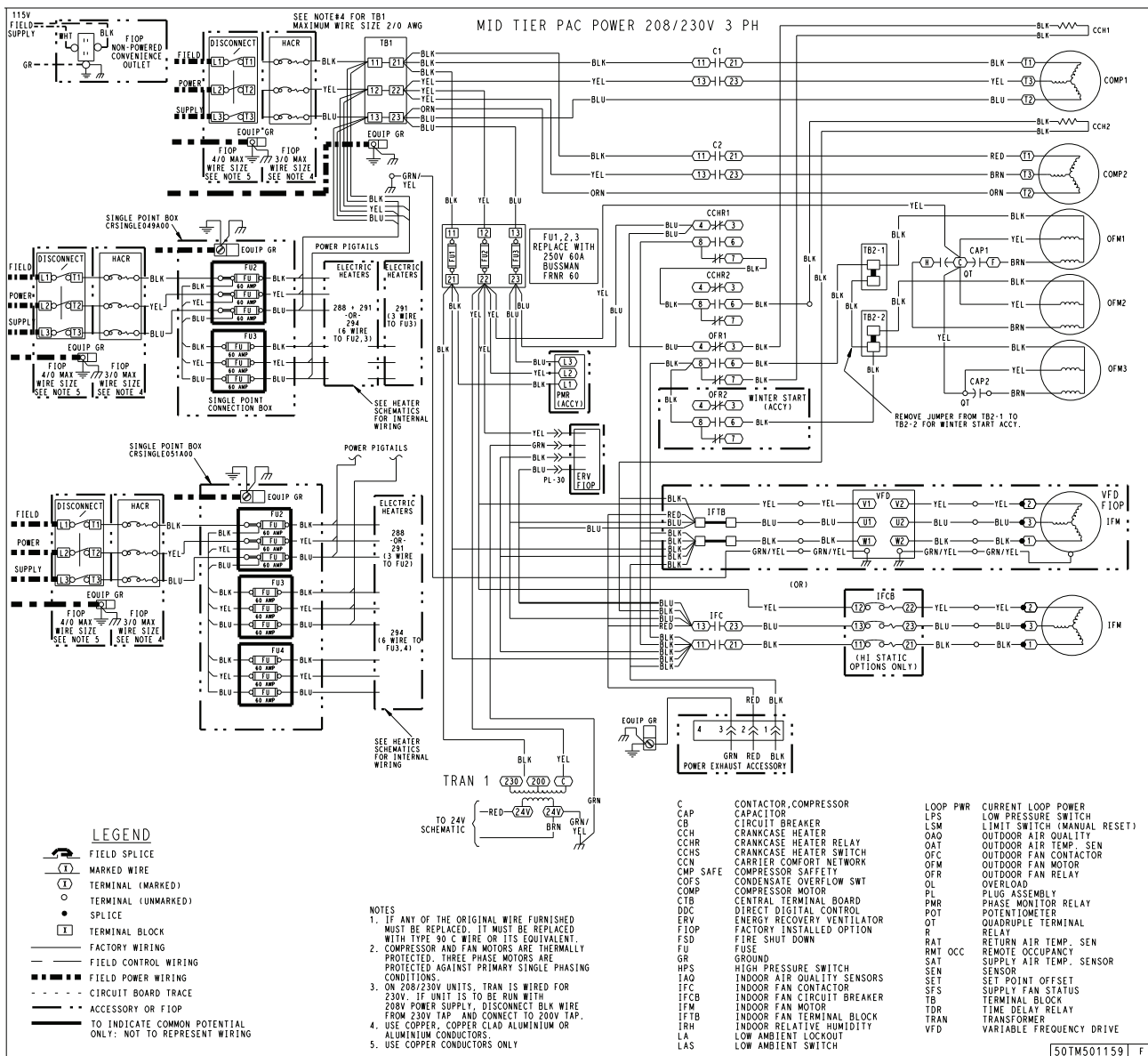
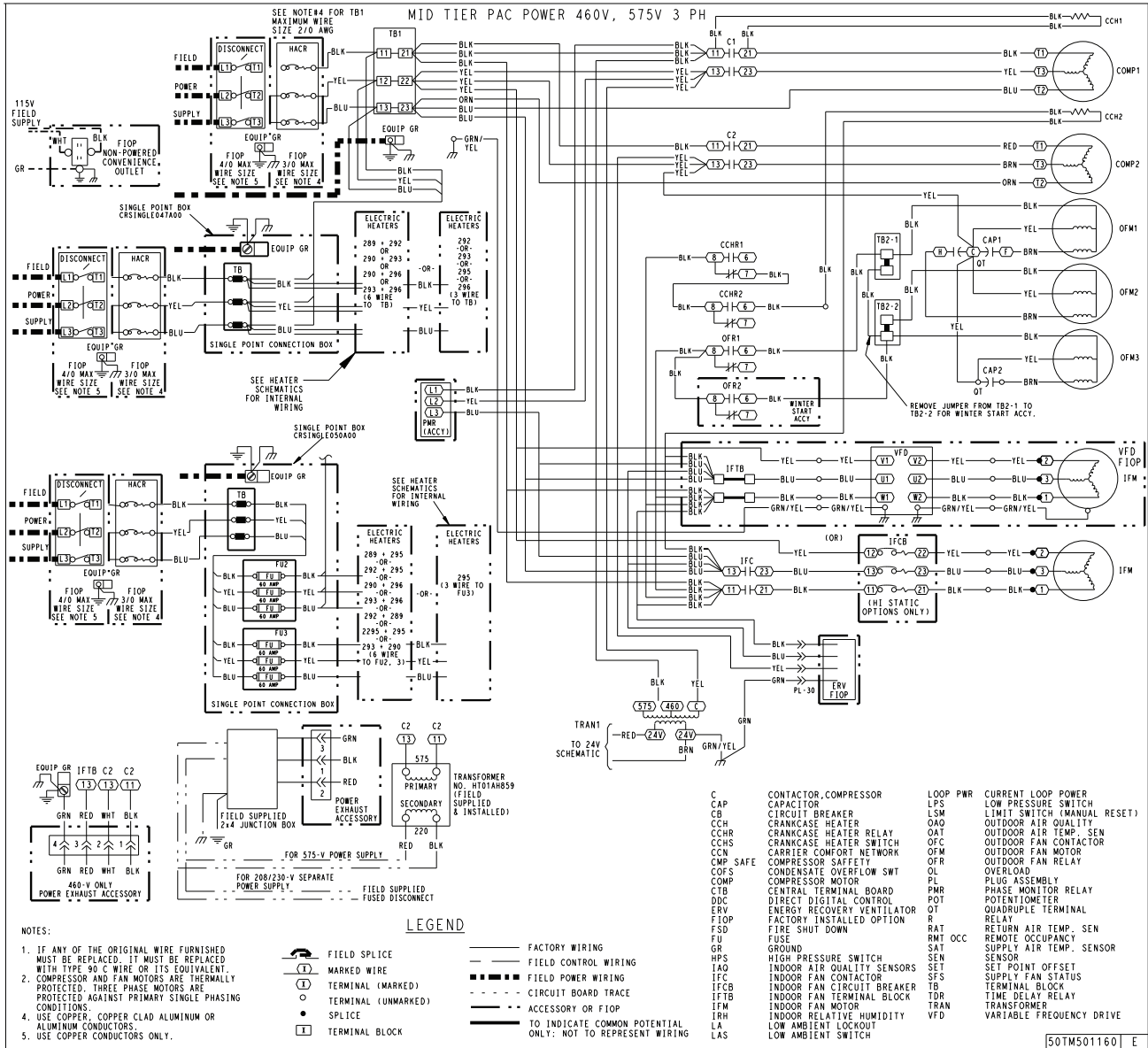

Fig. 76 - 50HC*D14 PAC Power Diagram - 230/460-3-60

A160148

APPENDIX IV. WIRING DIAGRAMS



50HC

Fig. 77 - 50HC* D14 PAC Power Diagram - 575-3-60

A160149

APPENDIX IV. WIRING DIAGRAMS

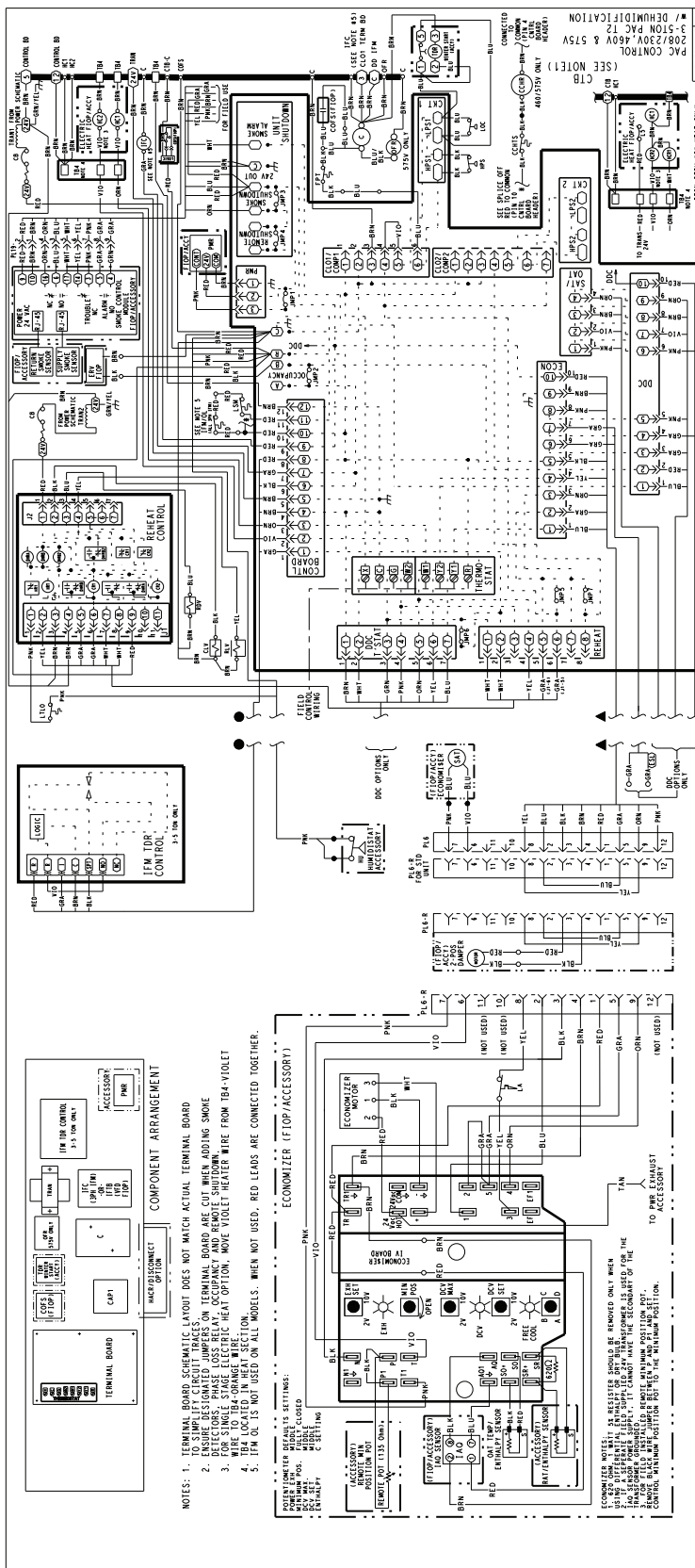

50HC

Fig. 78 - 50HC*A04-A06 PAC Control Diagram - 230-1-60; 230/460/575-3-60 with Humidi-MiZer™

A160150

APPENDIX IV. WIRING DIAGRAMS

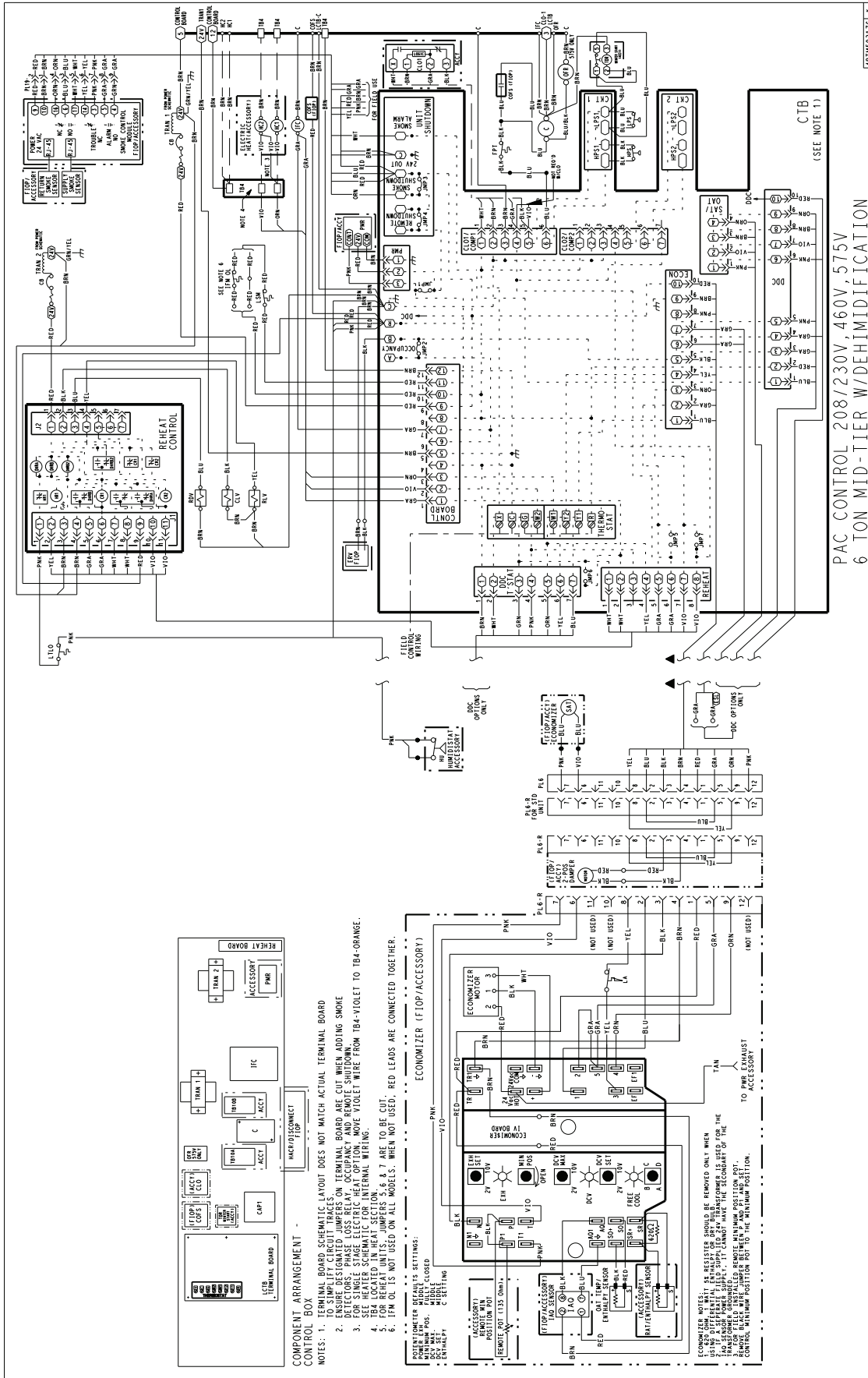

Fig. 79 - 50HC*A07 PAC Control Diagram - 230-1-60; 230/460/575-3-60 with Humidi-MiZer™

50HC

APPENDIX IV. WIRING DIAGRAMS

50HC

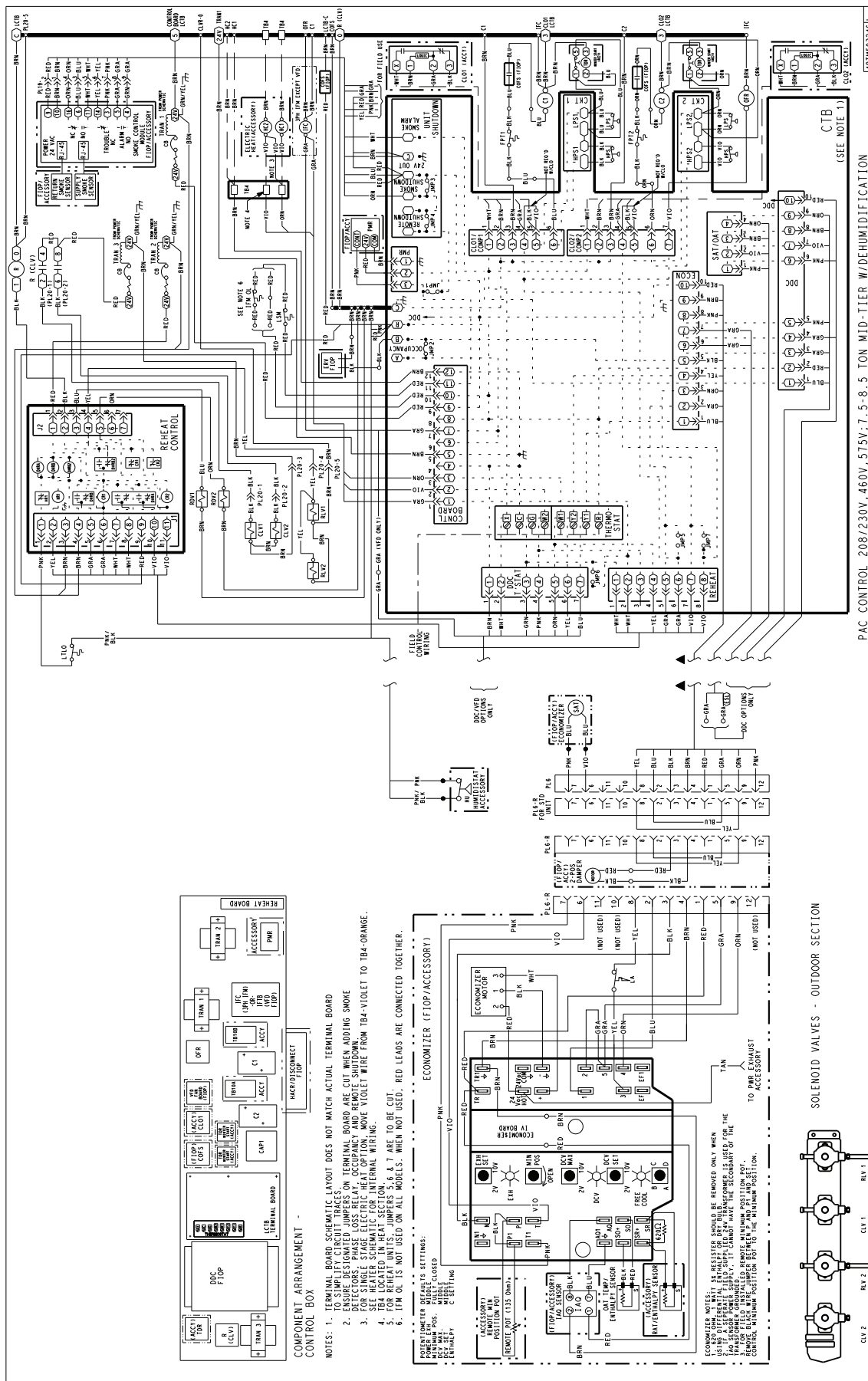

Fig. 80 - 50HC* D08-D09 PAC Control Diagram - 230/460/575-3-60 with Humidi-MiZer™

APPENDIX IV. WIRING DIAGRAMS

50HC

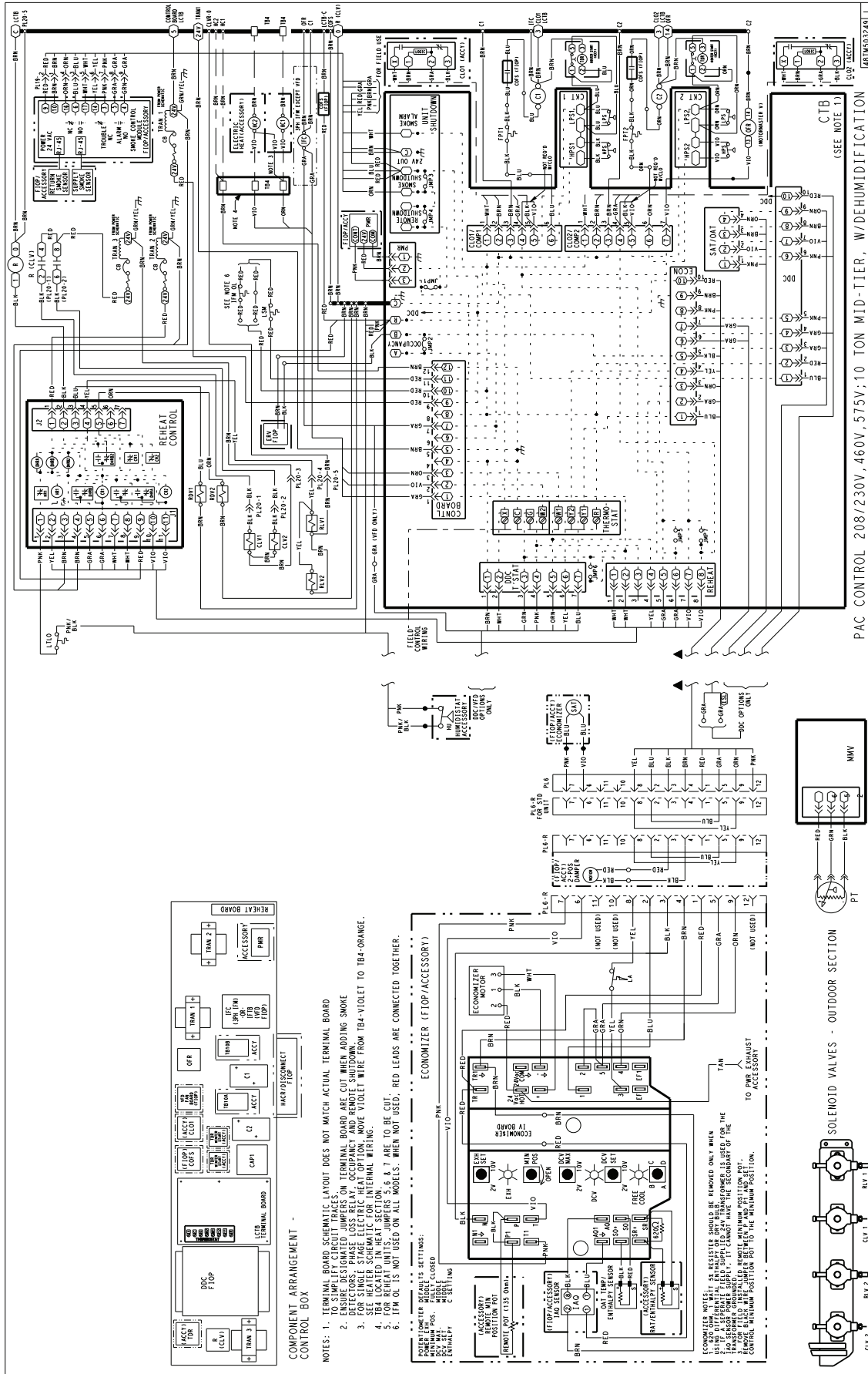

Fig. 82 - 50HC*D12 PAC Control Diagram - 230/460/575-3-60 with Humidi-MiZer™

A160153

APPENDIX IV. WIRING DIAGRAMS

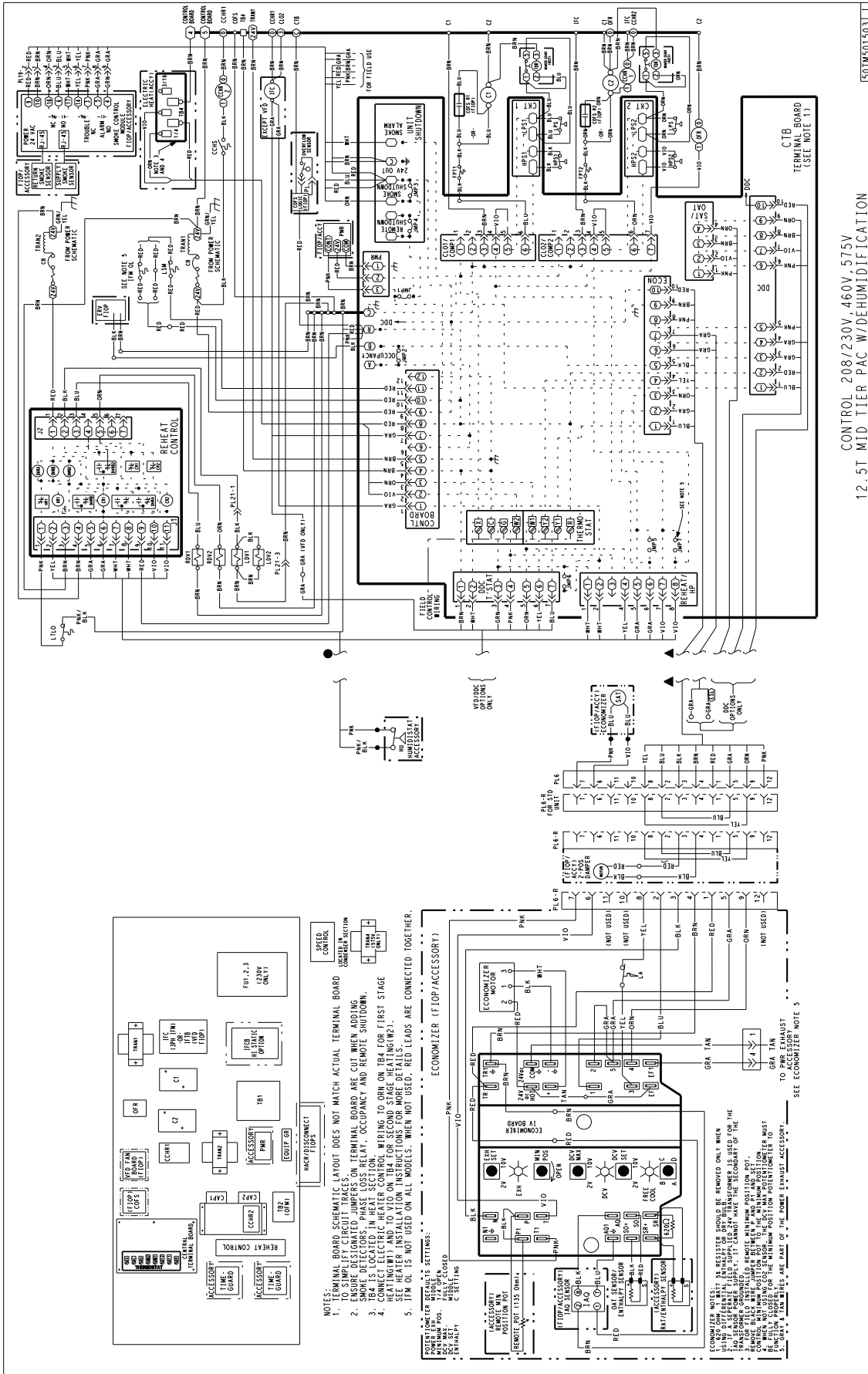

Fig. 83 - 50HC*D14 PAC Control Diagram - 230/460/575-3-60 with Humidi-MiZer™

CONTROL 208/230V, 460V, 575V
12.5T MID TIER PAC W/DEHUMIDIFICATION

50TM501503

50HC

APPENDIX IV. WIRING DIAGRAMS

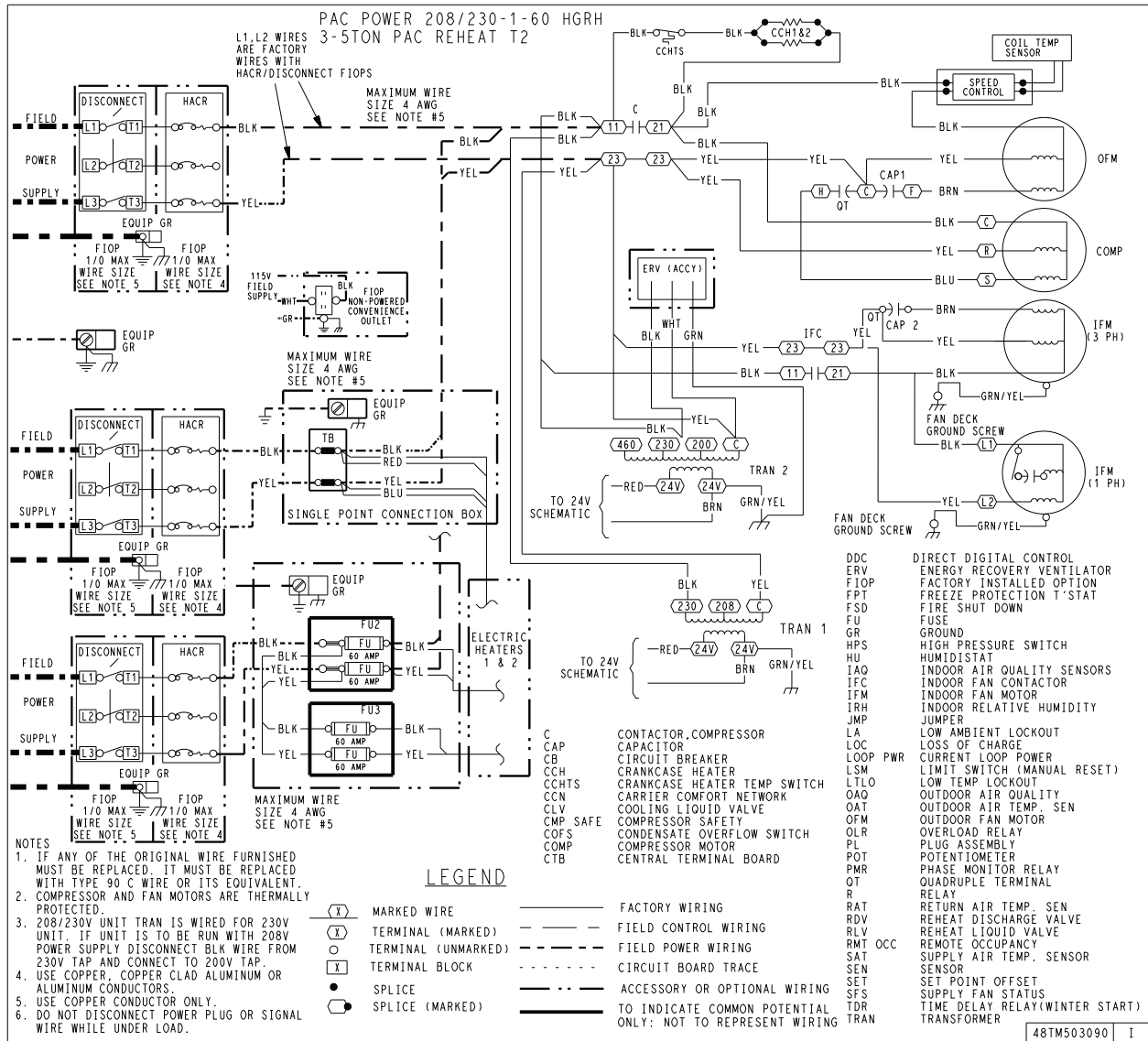
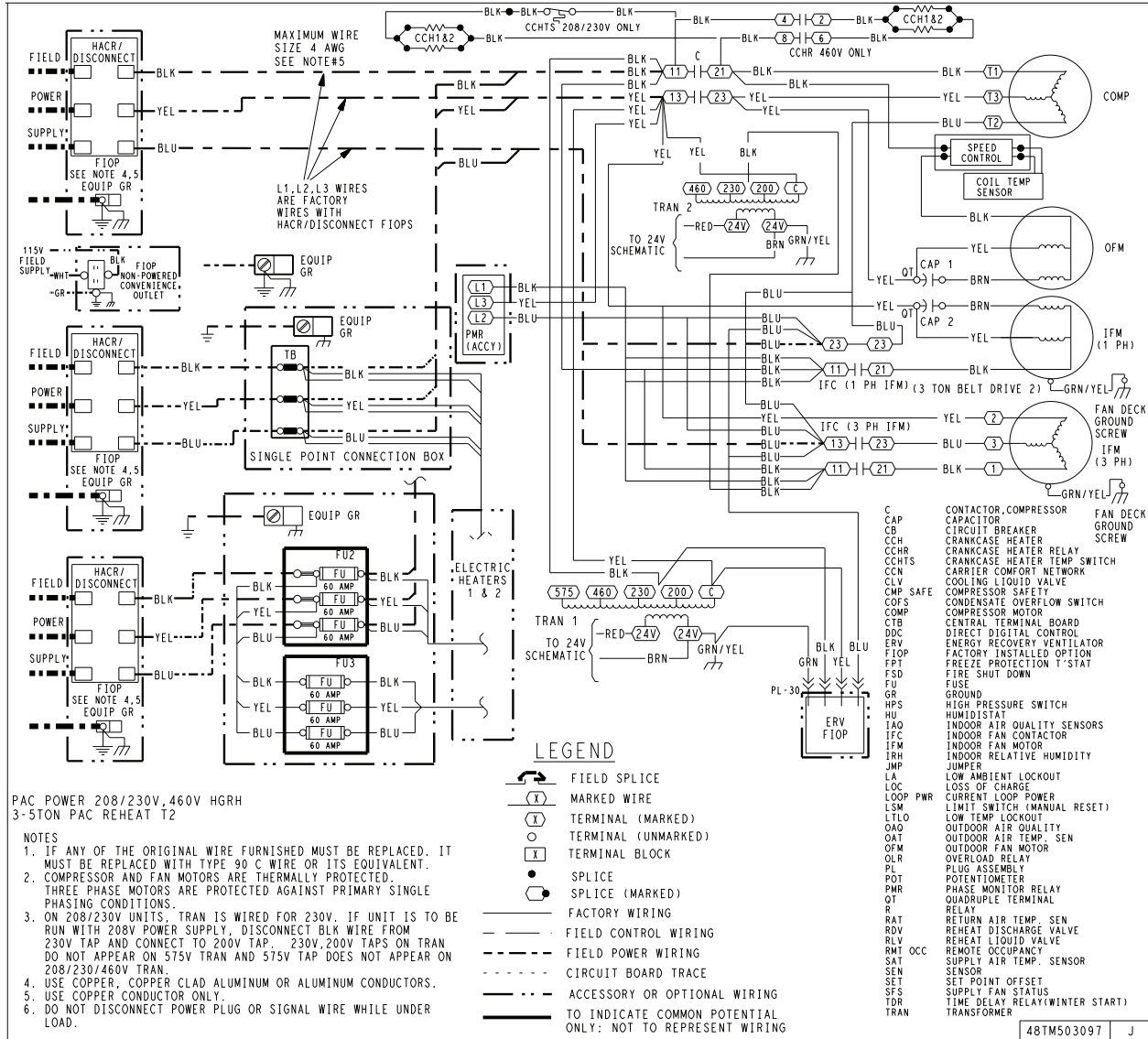

Fig. 84 - 50HC*A04-A06 PAC Power Diagram - 230-1-60 with Humidi-MiZer™

A160156

APPENDIX IV. WIRING DIAGRAMS



50HC

Fig. 85 - 50HC* A04-A06 PAC Power Diagram - 230/460-3-60 with Humidi-MiZer™

A160157

APPENDIX IV. WIRING DIAGRAMS

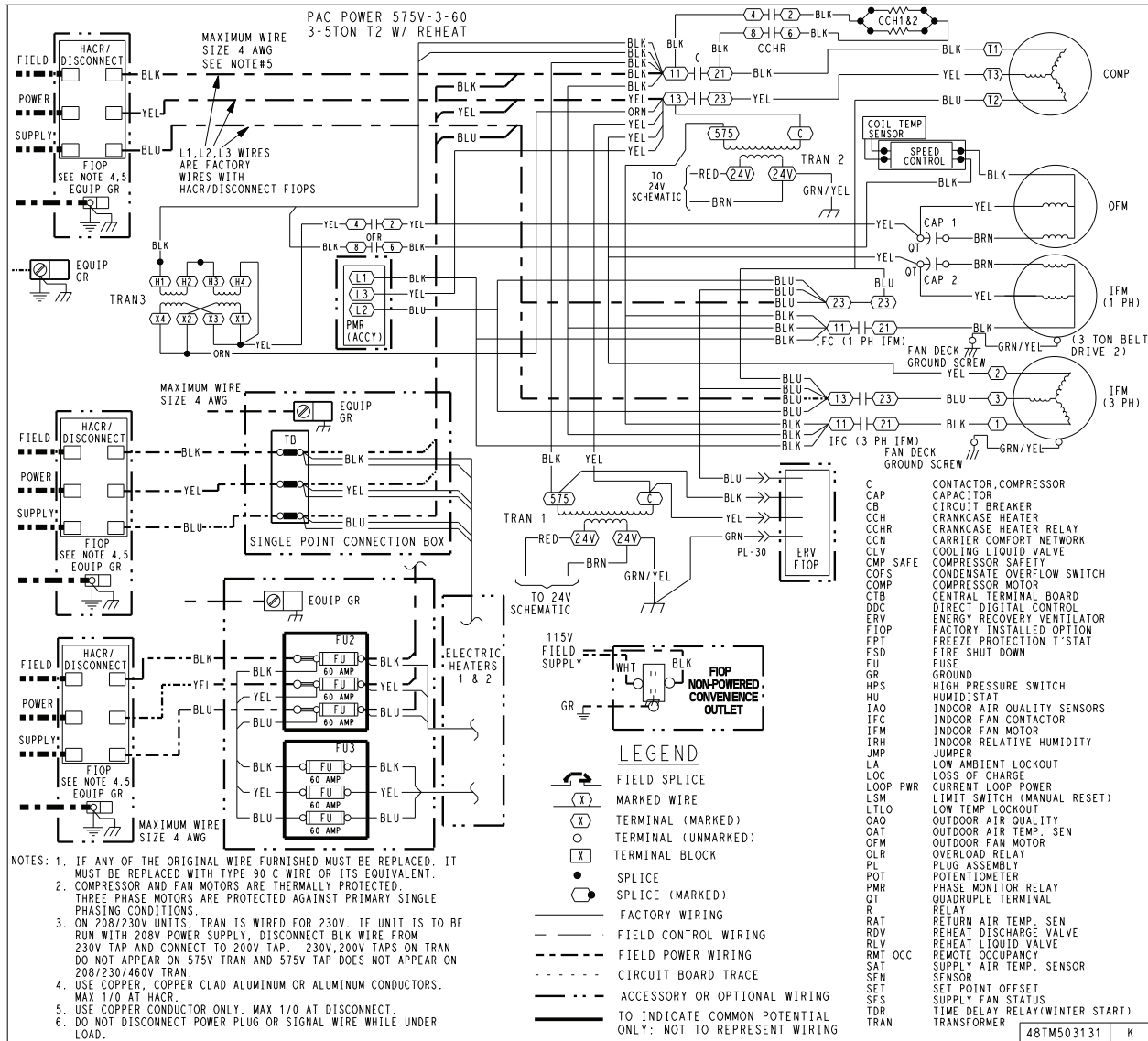
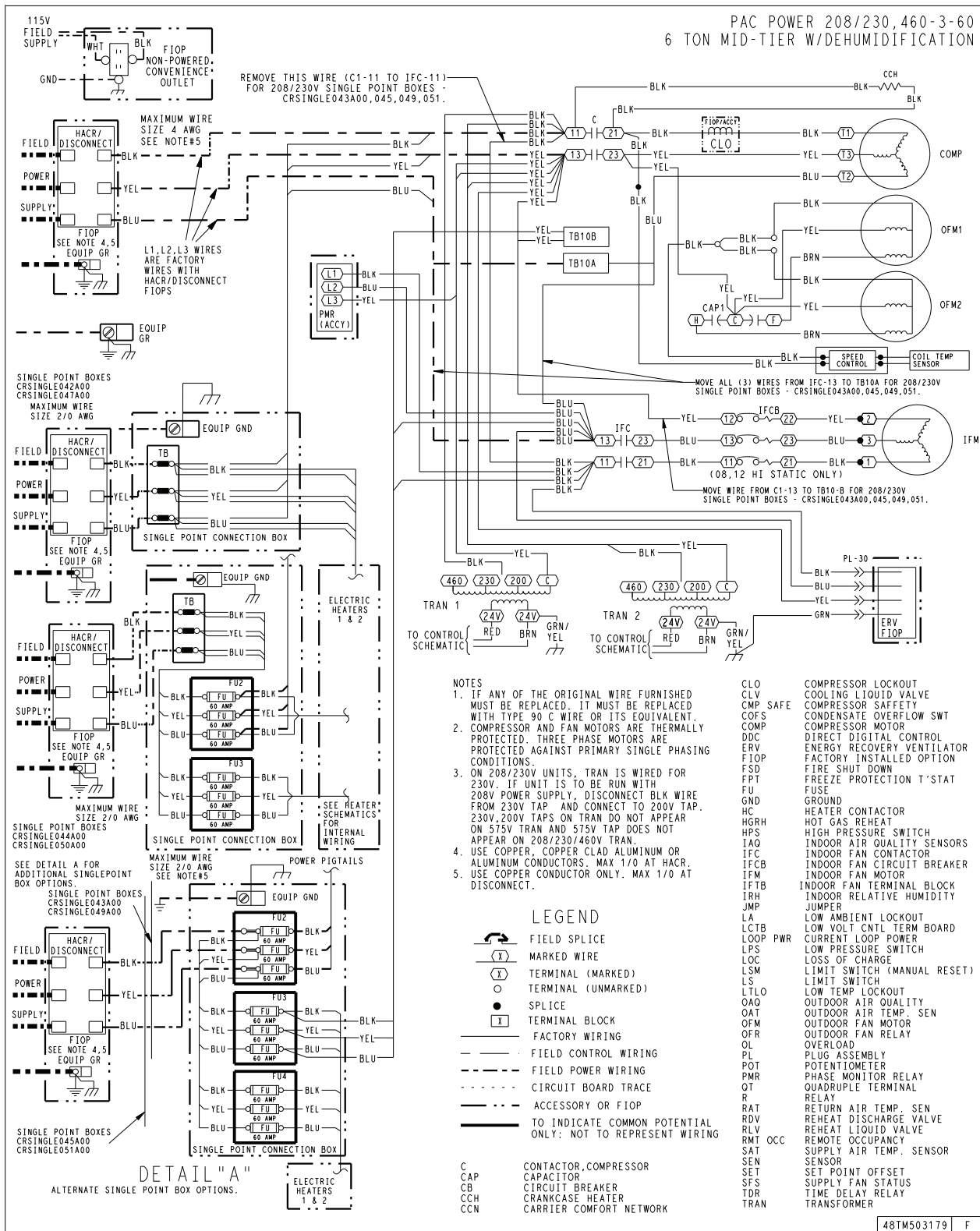

Fig. 86 - 50HC*A04-A06 PAC Power Diagram - 575-3-60 with Humidi-MiZer™

A160158

APPENDIX IV. WIRING DIAGRAMS



50HC

Fig. 87 - 50HC*A07 PAC Power Diagram - 230/460-3-60 with Humidi-MiZer™

A160159

APPENDIX IV. WIRING DIAGRAMS

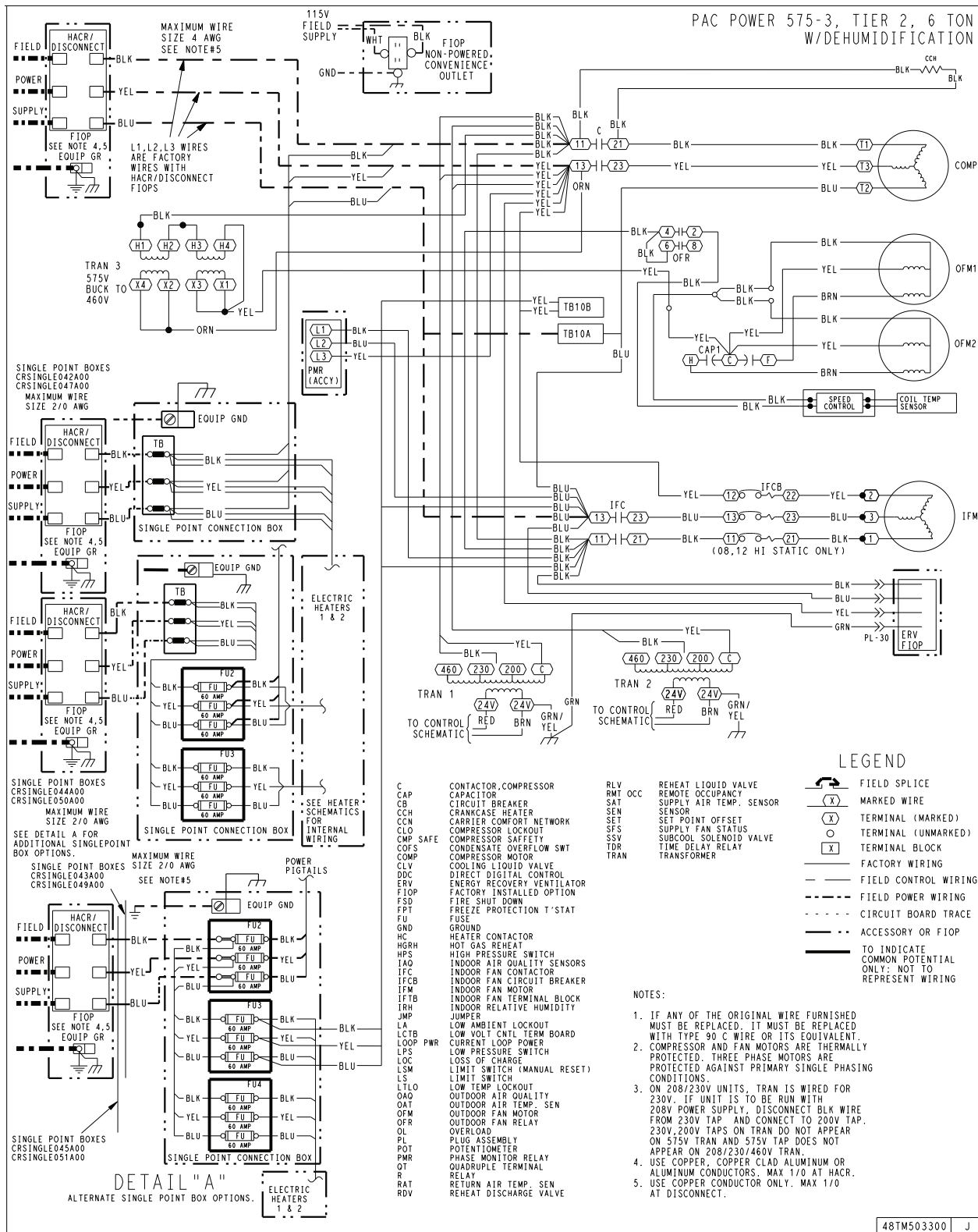

Fig. 88 - 50HC*A07 PAC Power Diagram - 575-3-60 with Humidi-MiZer™

A160160

APPENDIX IV. WIRING DIAGRAMS

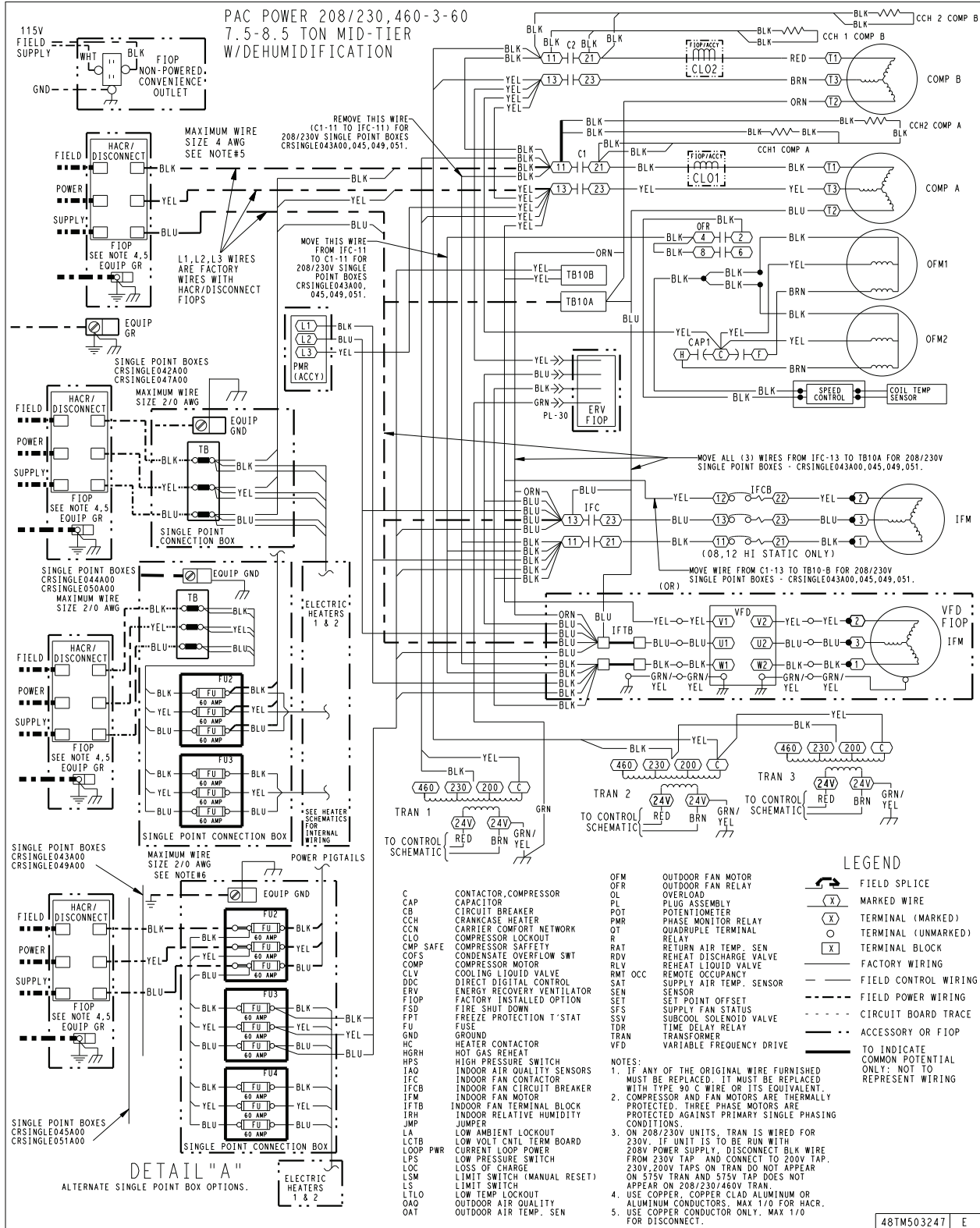

Fig. 89 - 50HC*D08-D09 PAC Power Diagram - 230/460-3-60 with Humidi-MiZer™

50HC

A160161

APPENDIX IV. WIRING DIAGRAMS

50HC

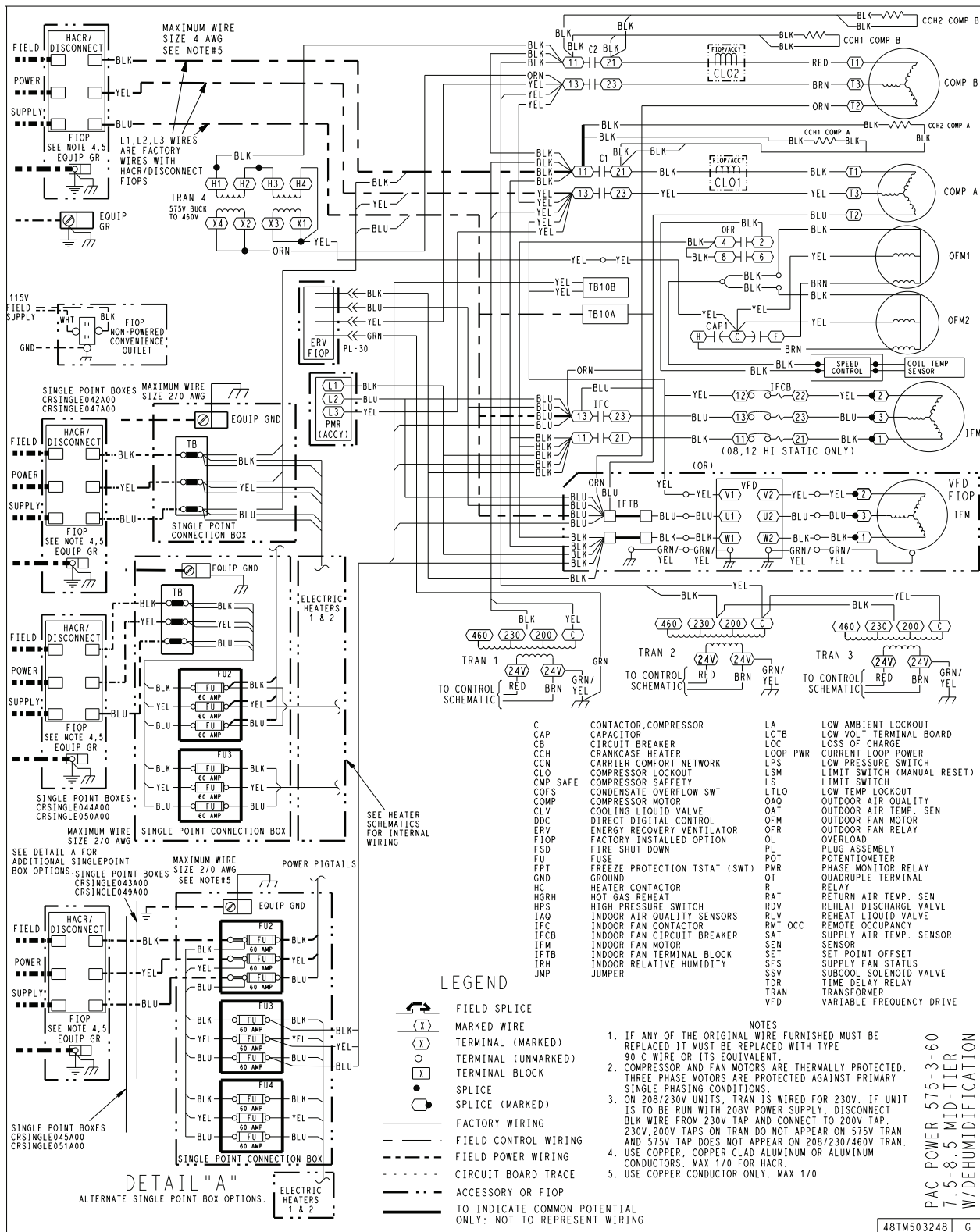
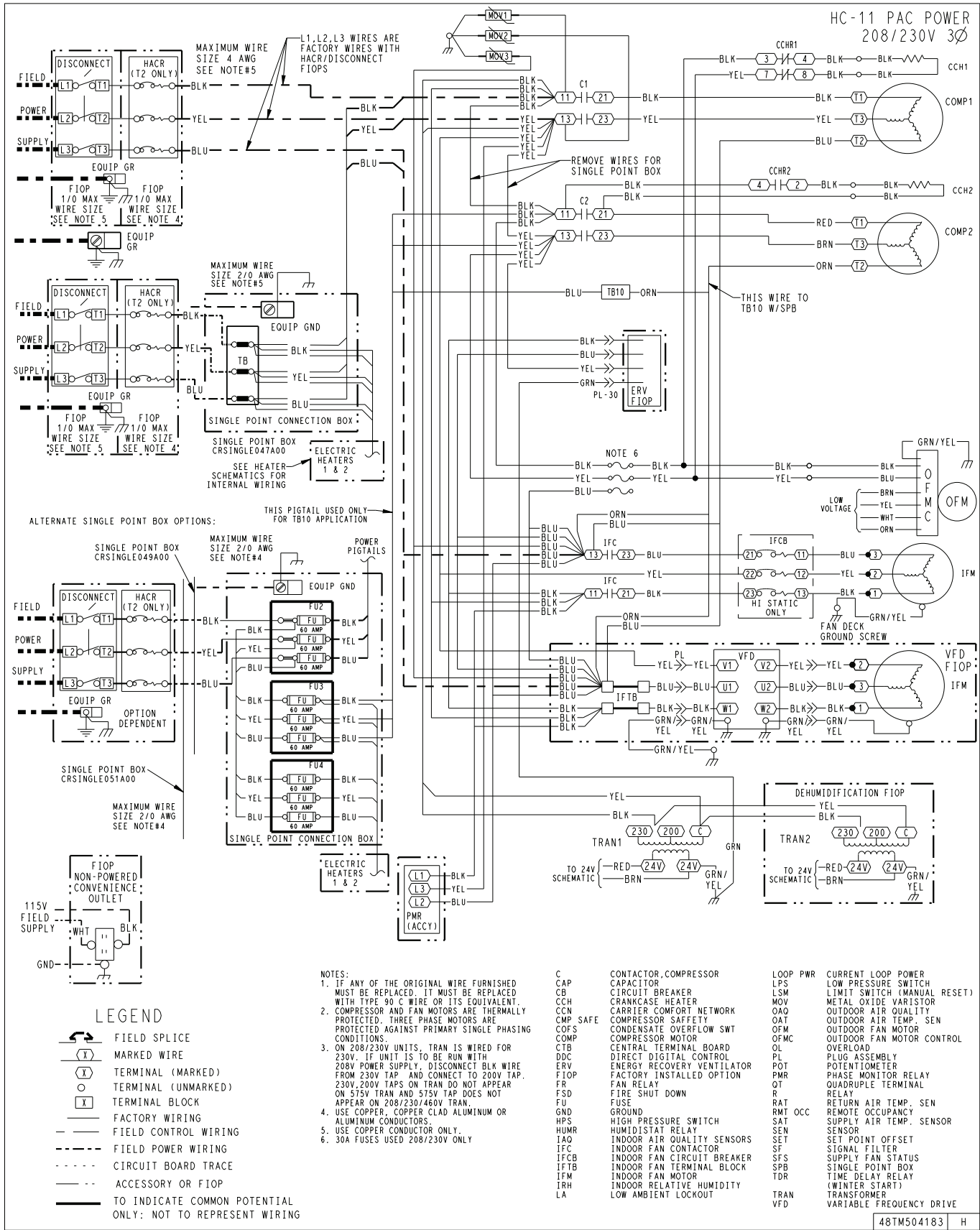

Fig. 90 - 50HC*D08-D09 PAC Power Diagram - 575-3-60 with Humidi-MiZer™

APPENDIX IV. WIRING DIAGRAMS



50HC

Fig. 91 - 50HC*D11 PAC Power Diagram - 230-3-60 with Humidi-MiZer™

APPENDIX IV. WIRING DIAGRAMS

50HC

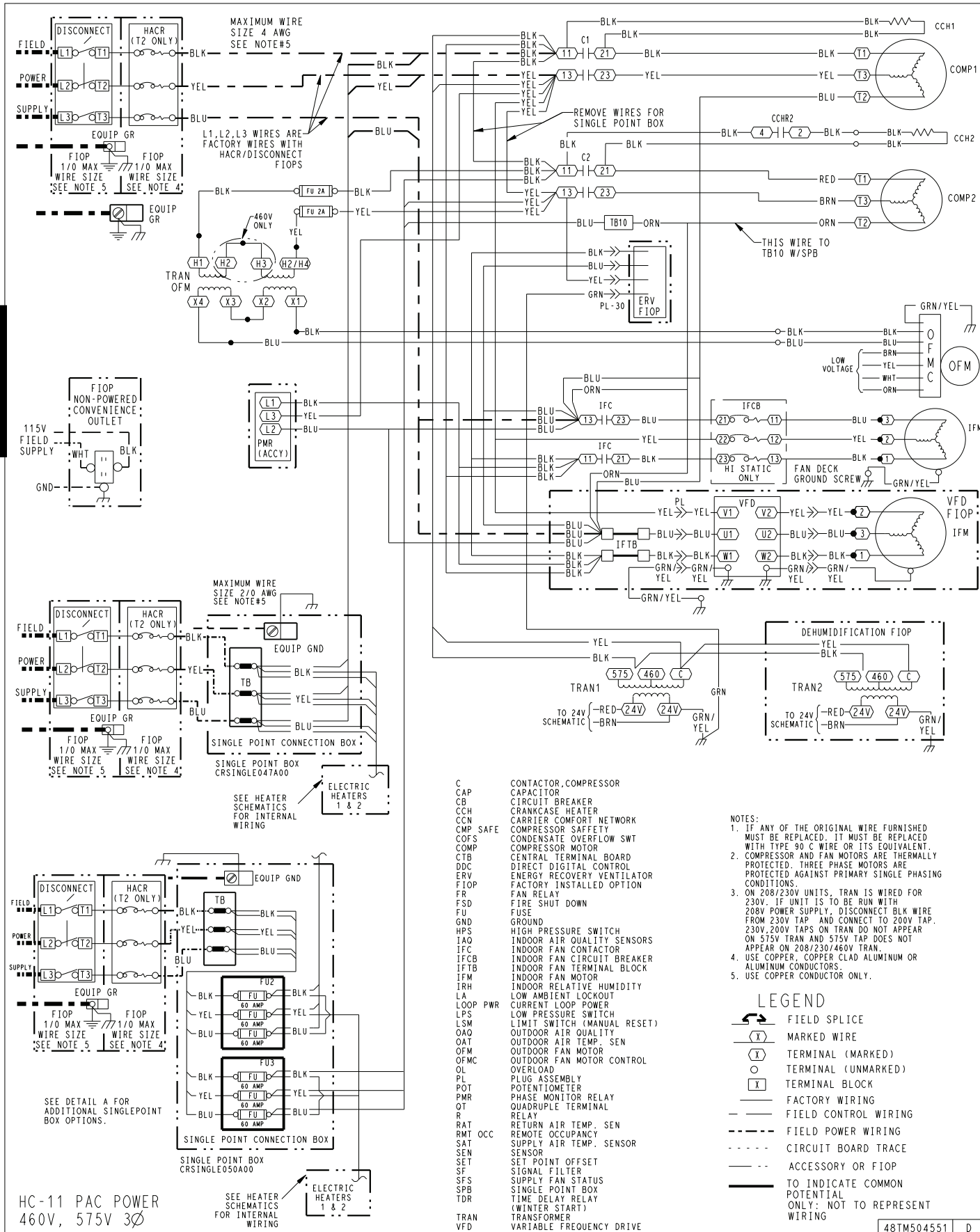

Fig. 92 - 50HC*D11 PAC Power Diagram - 460-3-60 with Humidi-MiZer™

A160147

APPENDIX IV. WIRING DIAGRAMS

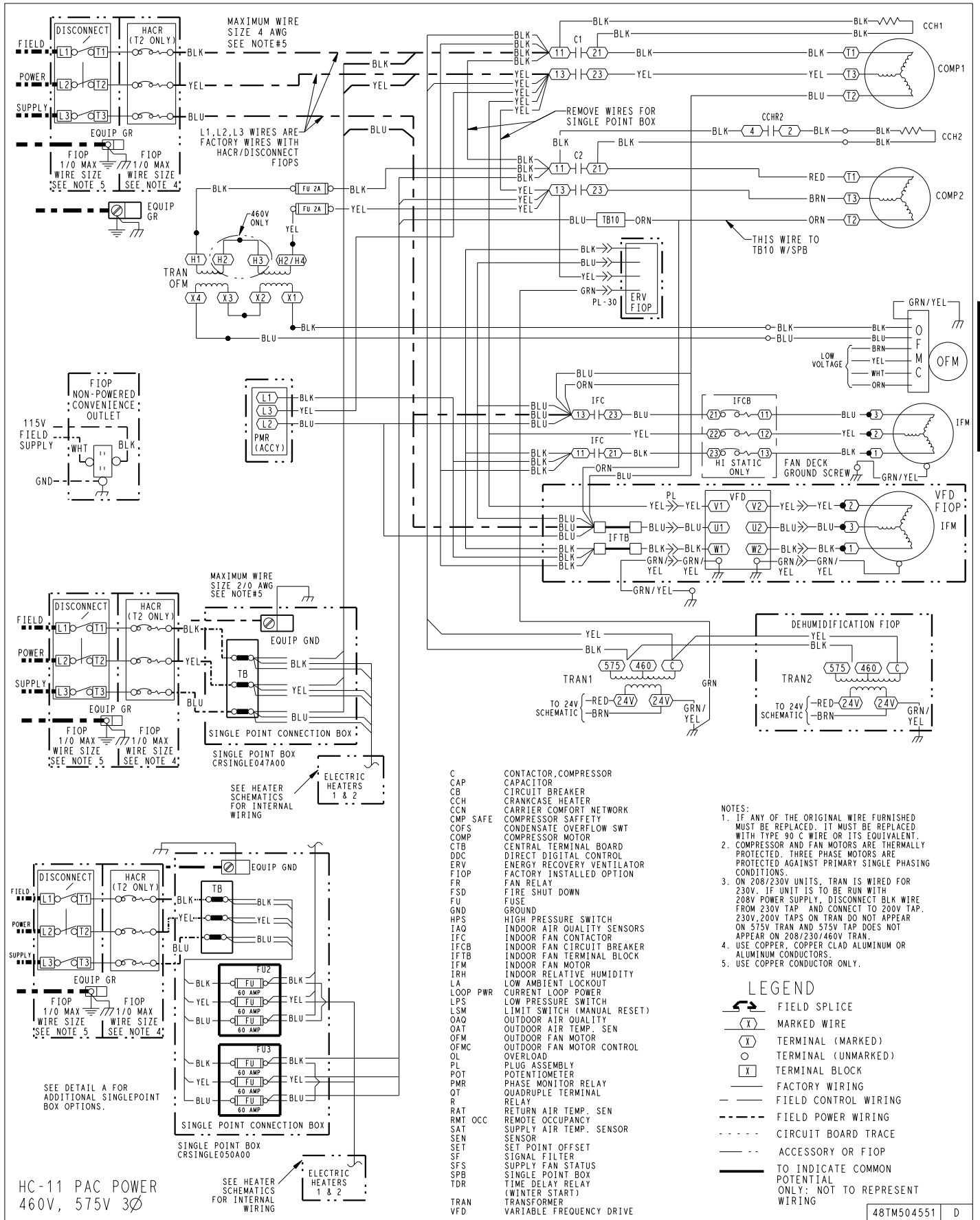

Fig. 93 - 50HC*D11 PAC Power Diagram - 575-3-60 with Humidi-MiZer™

A160147

APPENDIX IV. WIRING DIAGRAMS

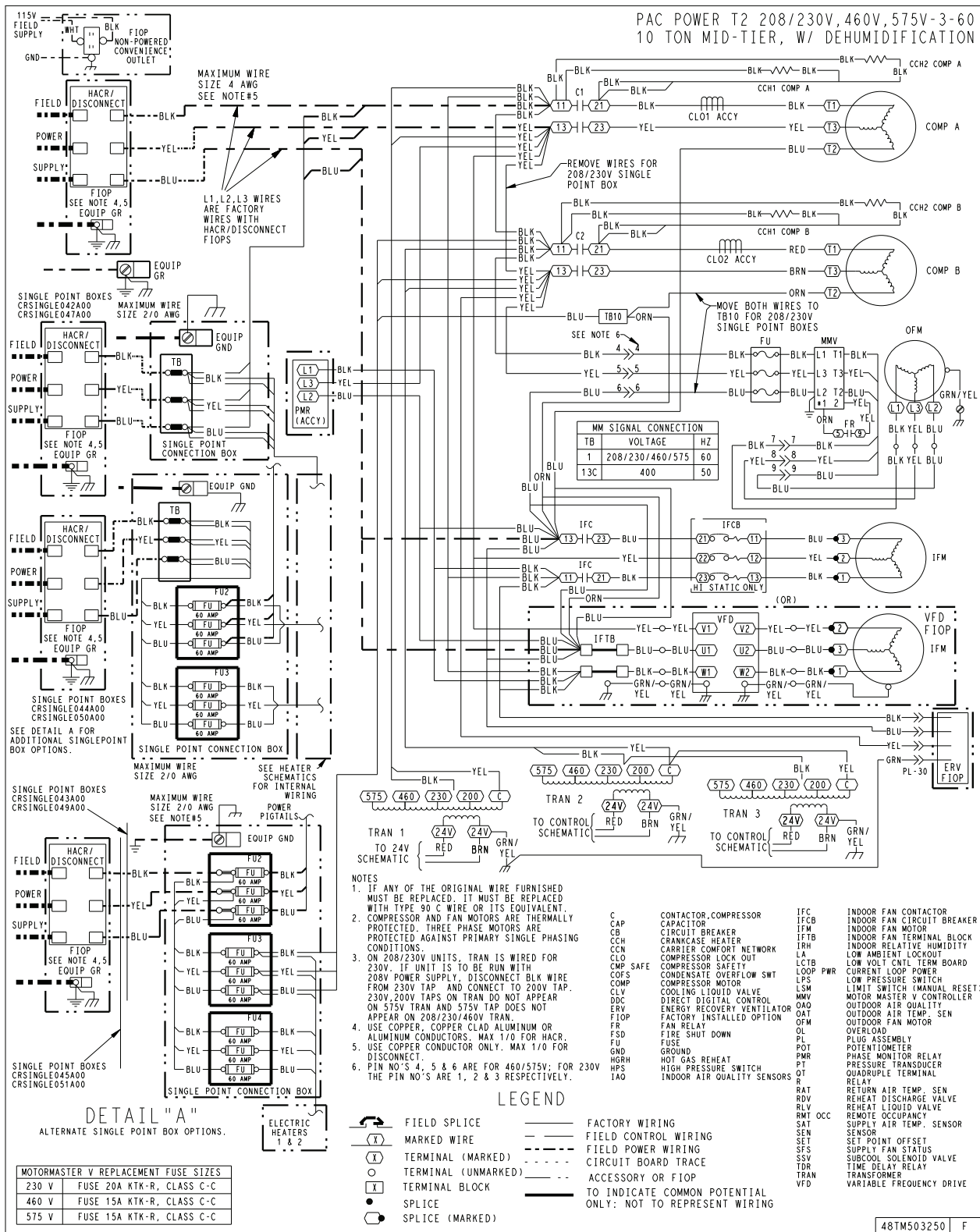
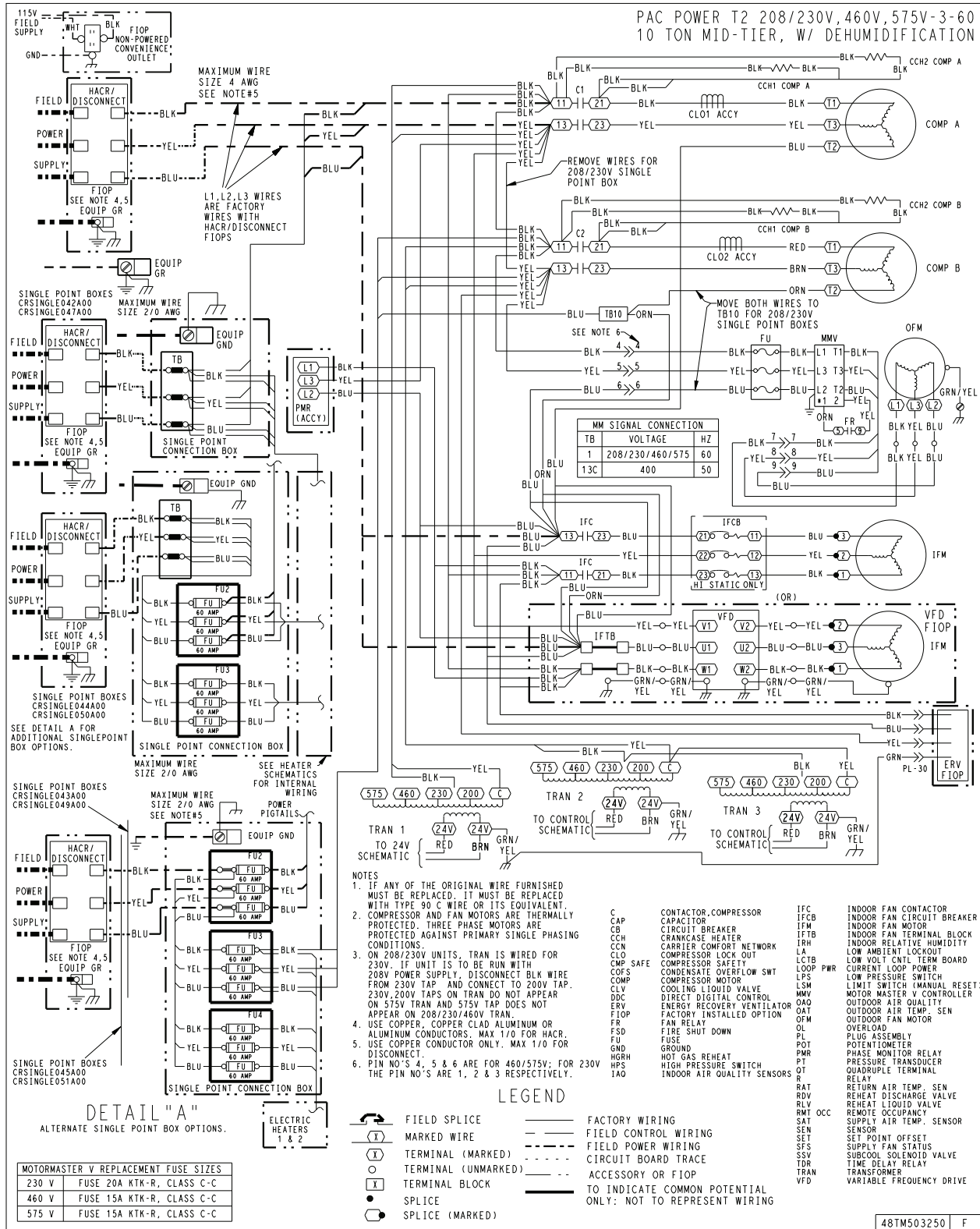

Fig. 94 - 50HC*D12 PAC Power Diagram - 230/460-3-60 with Humidi-MiZer™

A160163

APPENDIX IV. WIRING DIAGRAMS



50HC

Fig. 95 - 50HC*D12 PAC Power Diagram - 575-3-60 with Humidi-MiZer™

A160163

APPENDIX IV. WIRING DIAGRAMS

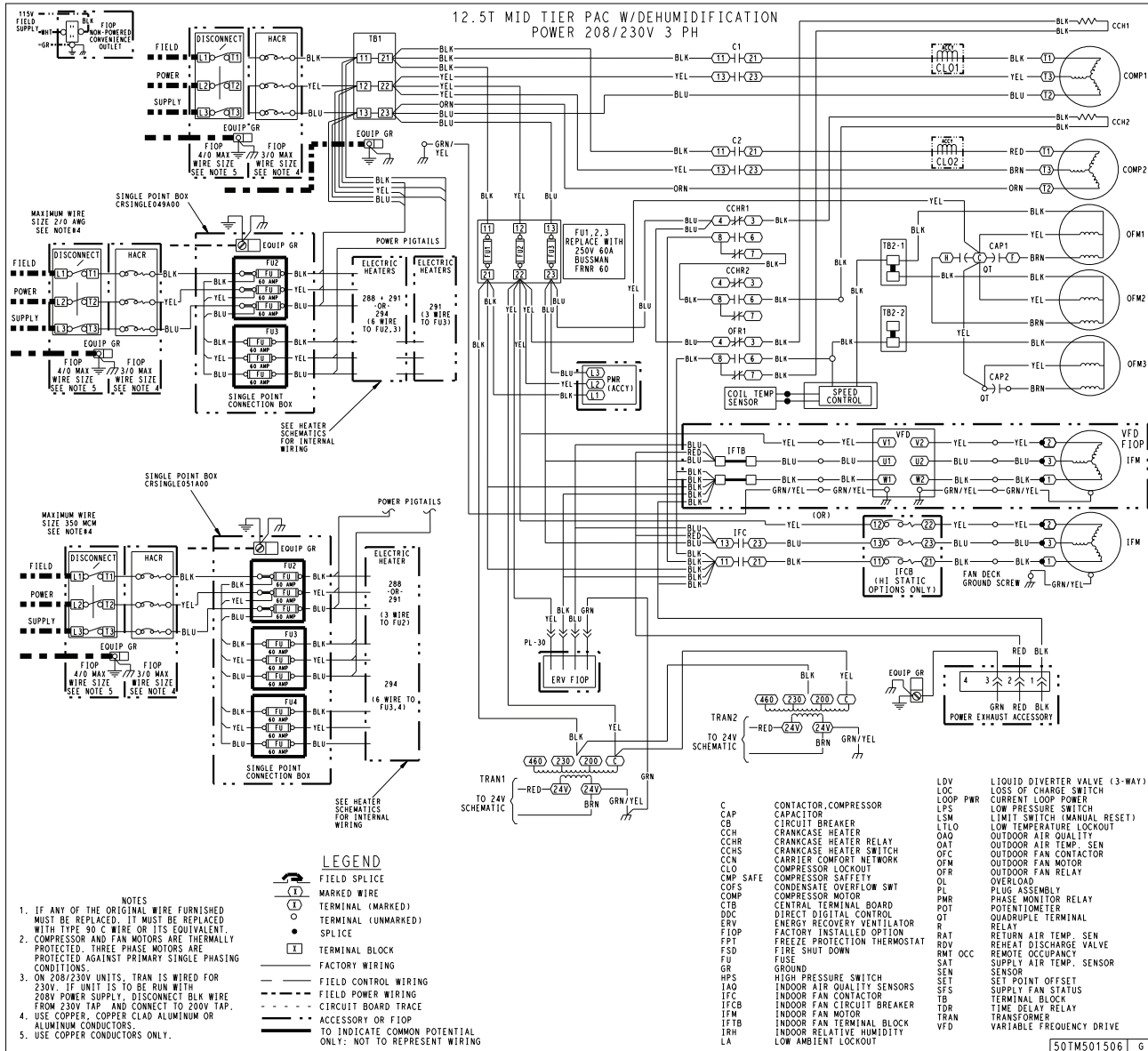
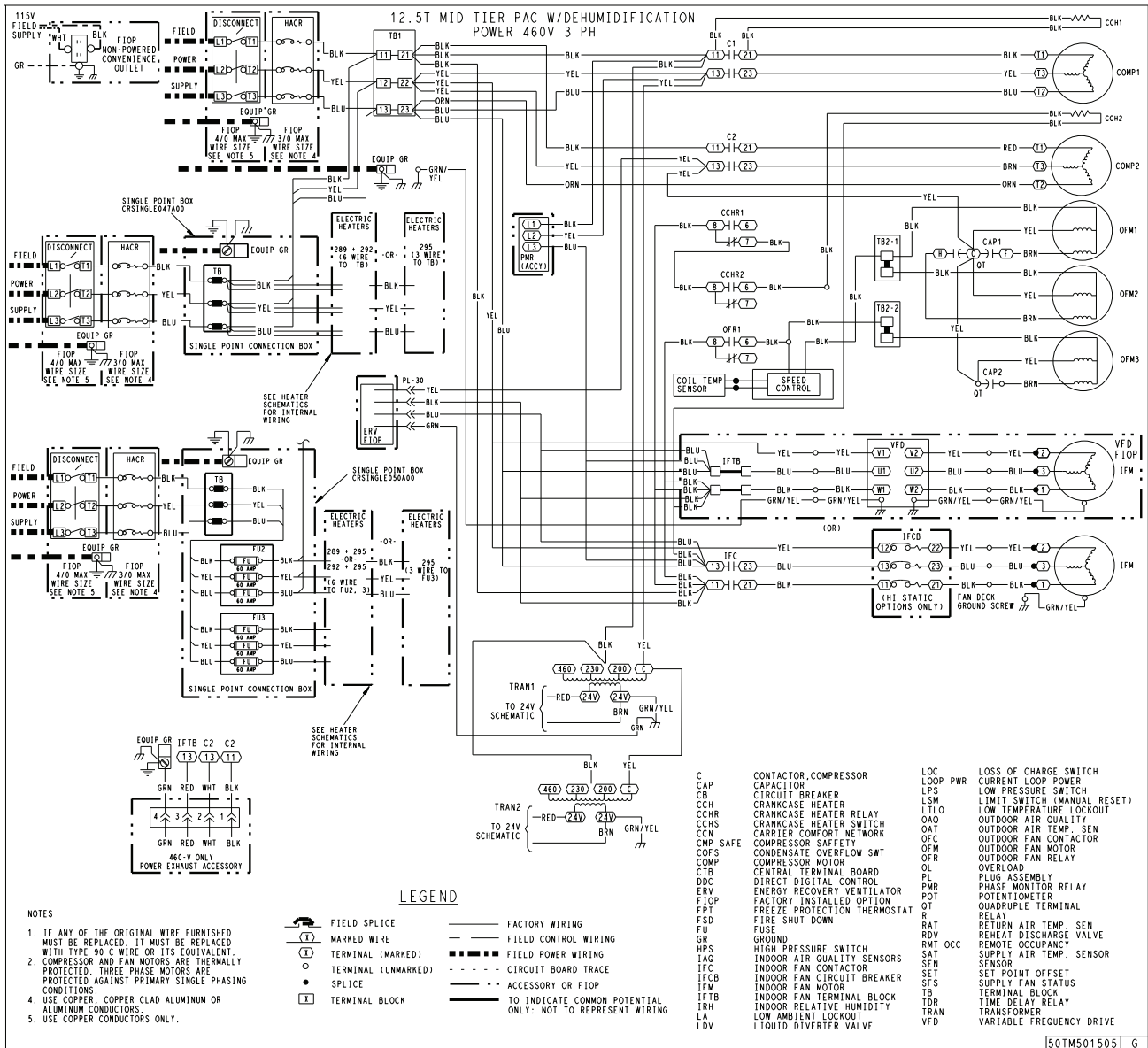

Fig. 96 - 50HC*D14 PAC Power Diagram - 230-3-60 with Humidi-MiZer™

A160165

APPENDIX IV. WIRING DIAGRAMS



50HC

Fig. 97 - 50HC*D14 PAC Power Diagram - 460-3-60 with Humidi-MiZer™

A160168

APPENDIX IV. WIRING DIAGRAMS

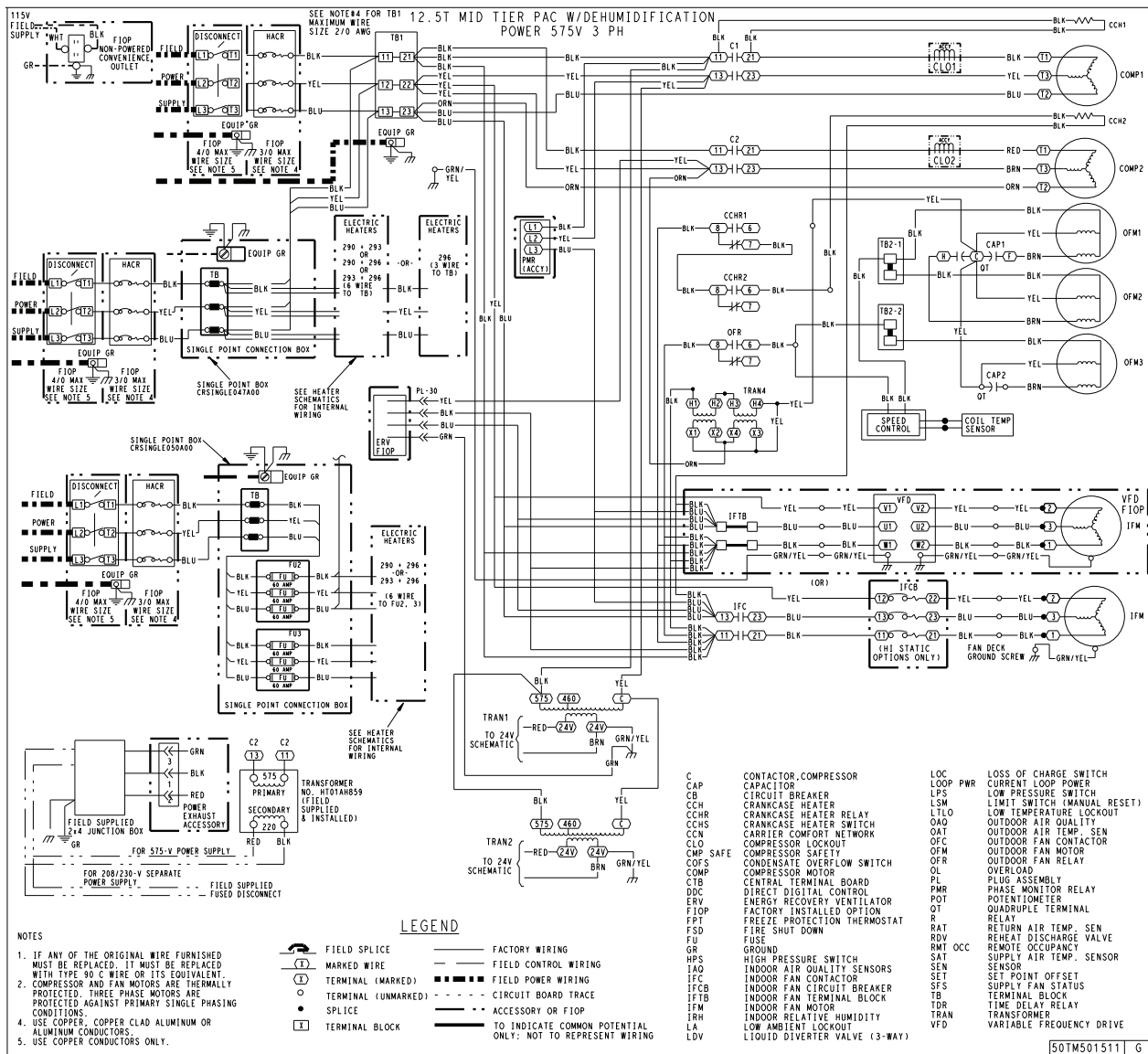
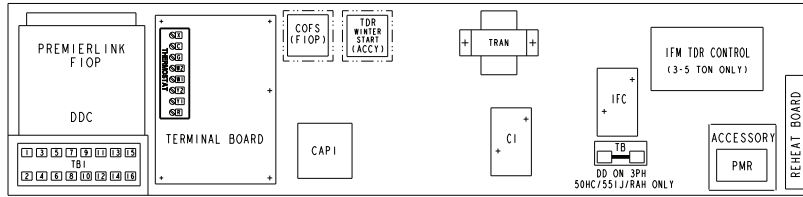

Fig. 98 - 50HC*D14 PAC Power Diagram - 575-3-60 with Humidi-MiZer™

A160166

APPENDIX IV. WIRING DIAGRAMS



COMPONENT ARRANGEMENT - (2) COMPRESSOR SHOWN

- NOTES:
1. TERMINAL BOARD SCHEMATIC LAYOUT DOES NOT MATCH ACTUAL TERMINAL BOARD TO SIMPLIFY CIRCUIT TRACES.
 2. ENSURE DESIGNATED JUMPERS ON TERMINAL BOARD ARE CUT WHEN ADDING SMOKE DETECTORS, PHASE LOSS RELAY, OCCUPANCY AND REMOTE SHUTDOWN.
 3. FOR SINGLE STAGE ELECTRIC HEAT OPTION, MOVE VIOLET HEATER WIRE FROM TB4-VIOLET WIRE TO TB4-ORANGE WIRE.
 4. TB4 IS LOCATED IN HEAT SECTION.
 5. IFC OCCURS WITHOUT DIRECT DRIVE ONLY.
 6. MARKED WIRE: ESL - ENTH SENSR LO (FROM TERM BD ECON 7)

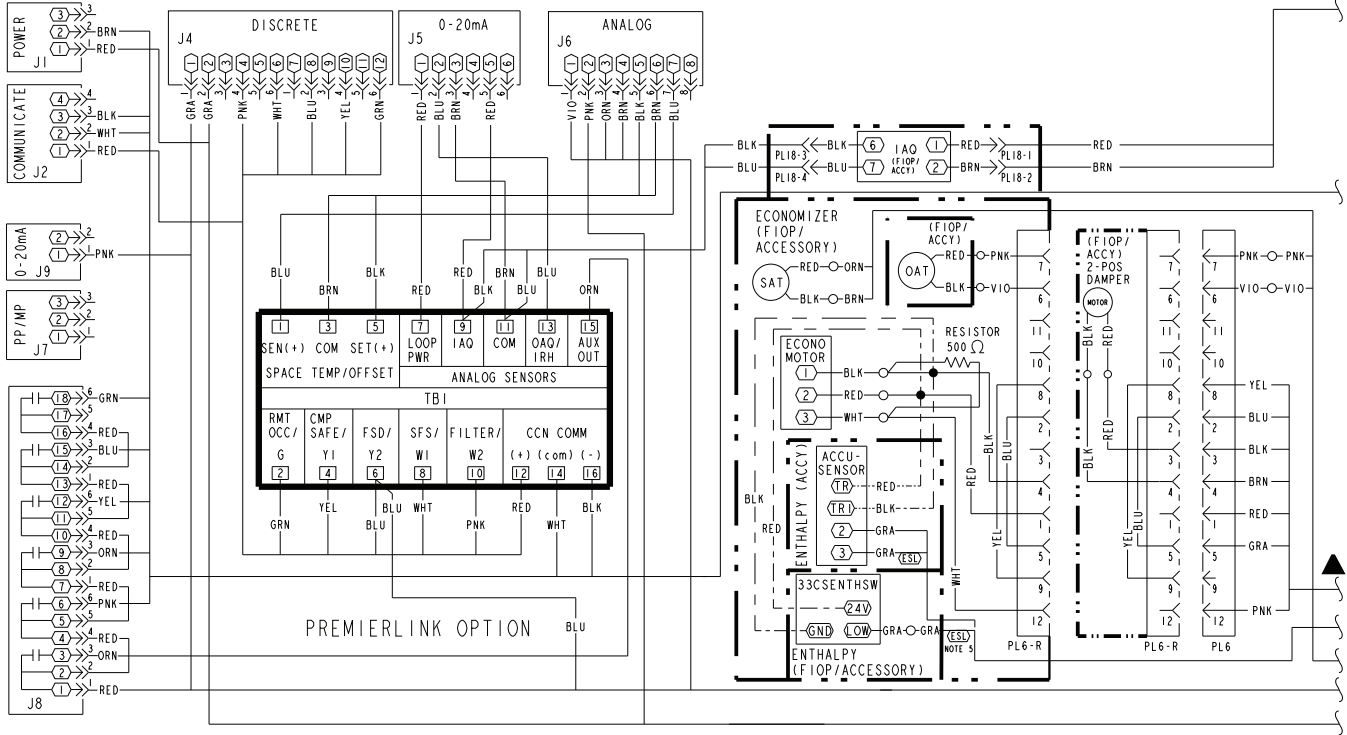
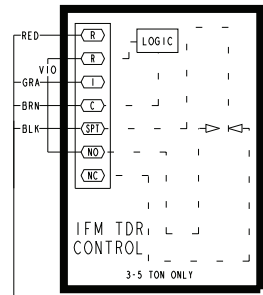

50HC

48TM500983 L

A160178

Fig. 99 - PremierLink™ System A04-A06 Wiring Diagram

APPENDIX IV. WIRING DIAGRAMS

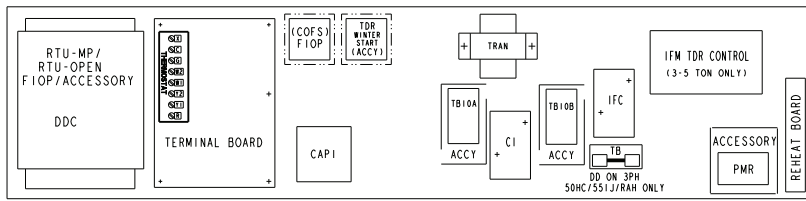

COMPONENT ARRANGEMENT - (2) COMPRESSOR SHOWN

- NOTES:
1. TERMINAL BOARD SCHEMATIC LAYOUT DOES NOT MATCH ACTUAL TERMINAL BOARD TO SIMPLIFY CIRCUIT TRACES.
 2. ENSURE DESIGNATED JUMPERS ON TERMINAL BOARD ARE CUT WHEN ADDING SMOKE DETECTORS, PHASE LOSS RELAY, OCCUPANCY AND REMOTE SHUTDOWN.
 3. FOR SINGLE STAGE ELECTRIC HEAT OPTION, MOVE VIOLET HEATER WIRE FROM TB4-VIOLET WIRE TO TB4-ORANGE WIRE.
 4. TB4 LOCATED IN HEAT SECTION.
 5. IFC OCCURS WITHOUT DIRECT DRIVE ONLY.
 6. MARKED WIRE: (ESL) - ENTH SENSR LO (FROM TERM BD ECON LO)

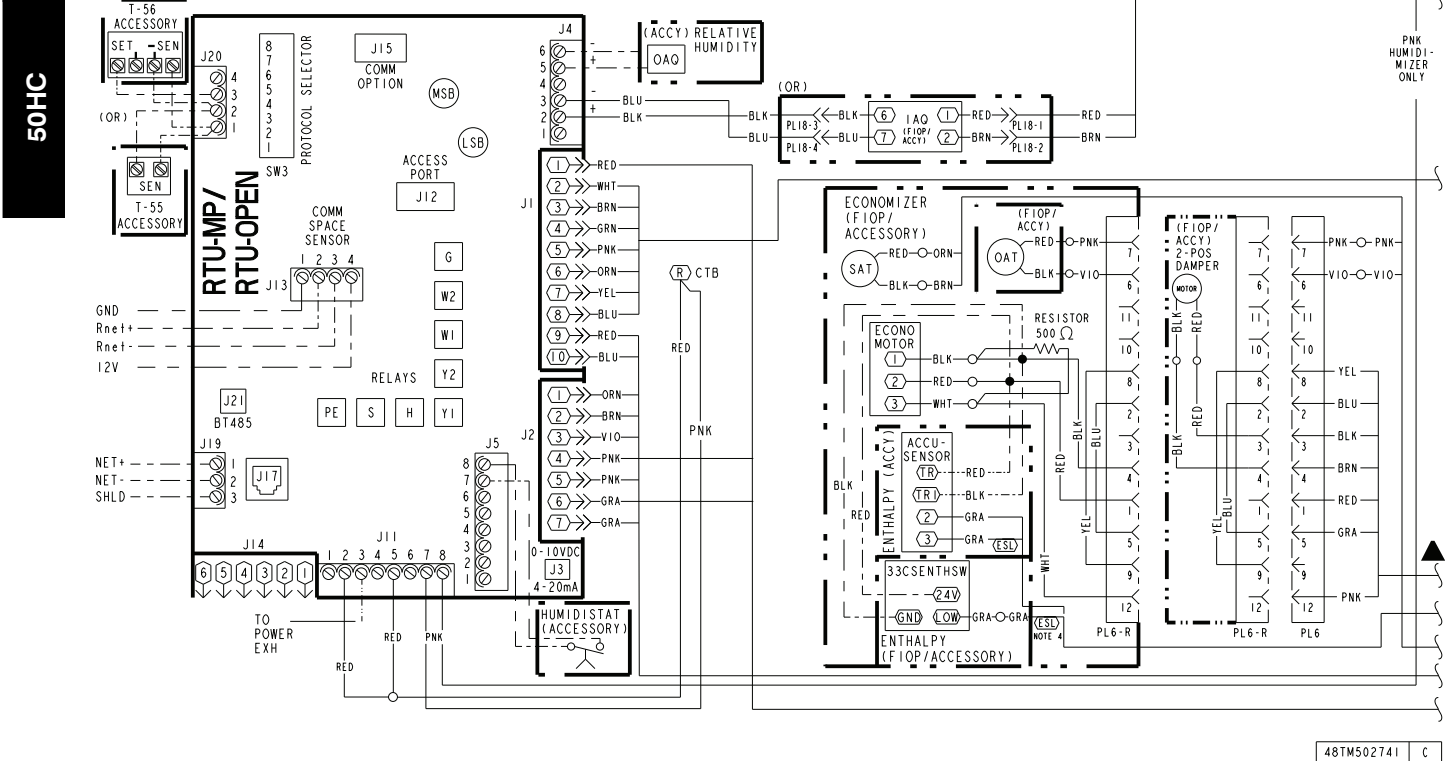
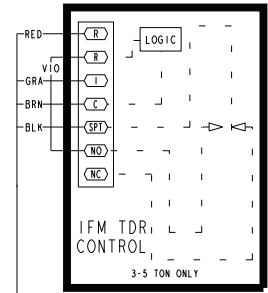

48TM502741 C

Fig. 100 - RTU Open System Control A04-A06 Wiring Diagram

A160179

APPENDIX IV. WIRING DIAGRAMS

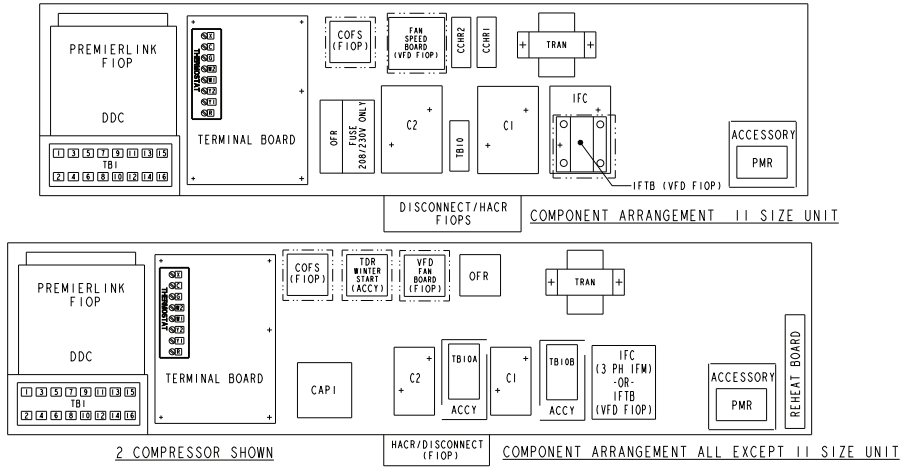

- NOTES:
1. TERMINAL BOARD SCHEMATIC LAYOUT DOES NOT MATCH ACTUAL TERMINAL BOARD TO SIMPLIFY CIRCUIT TRACES.
 2. ENSURE DESIGNATED JUMPERS ON TERMINAL BOARD ARE CUT WHEN ADDING SMOKE DETECTORS, PHASE LOSS RELAY, OCCUPANCY AND REMOTE SHUTDOWN.
 3. FOR SINGLE STAGE ELECTRIC HEAT OPTION, MOVE VIOLET HEATER WIRE FROM TB4-VIOLET WIRE TO TB4-ORANGE WIRE.
 4. TB4 IS LOCATED IN HEAT SECTION.
 5. IFC OCCURS WITHOUT DIRECT DRIVE ONLY.
 6. MARKED WIRE: (ESL)- ENTH SENSR LO (FROM TERM BD ECON 7)

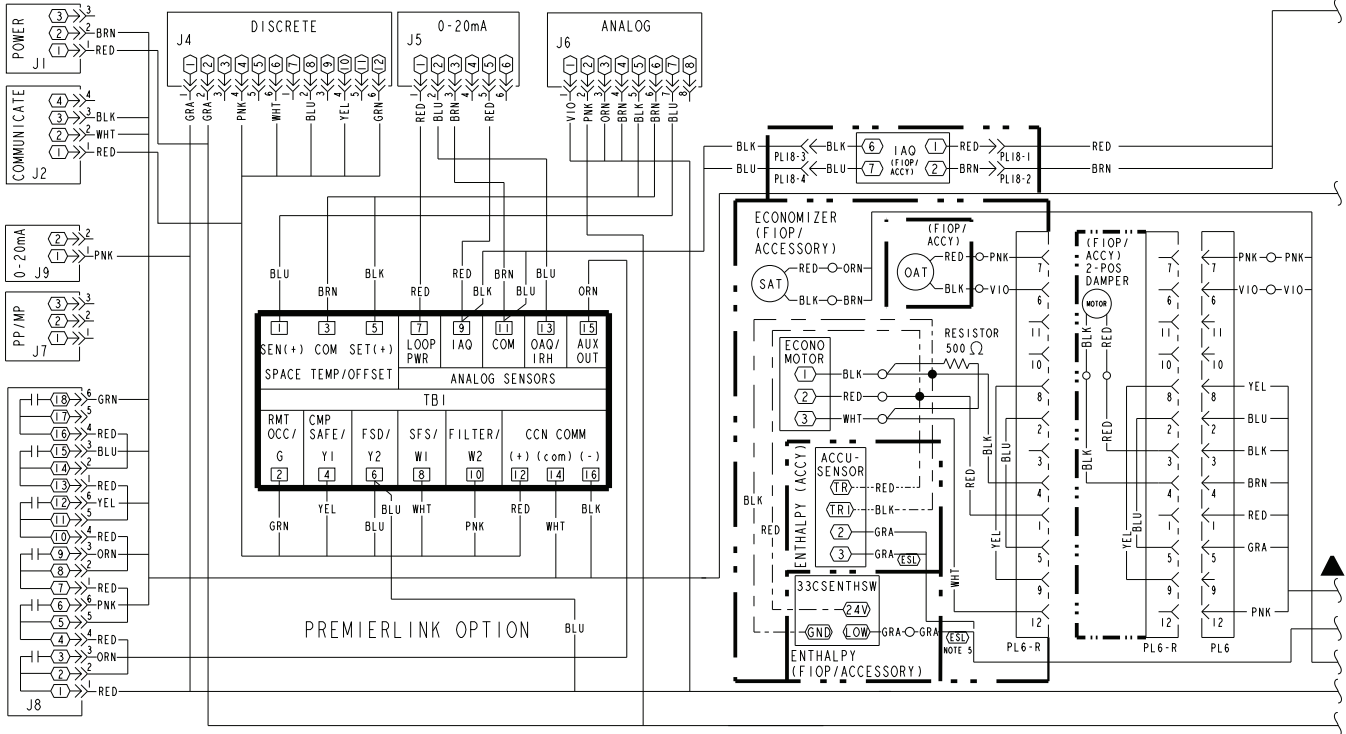

48TM504587
A160180

Fig. 101 - PremierLink™ System A07 - D14 Wiring Diagram

50HC

APPENDIX IV. WIRING DIAGRAMS

50HC

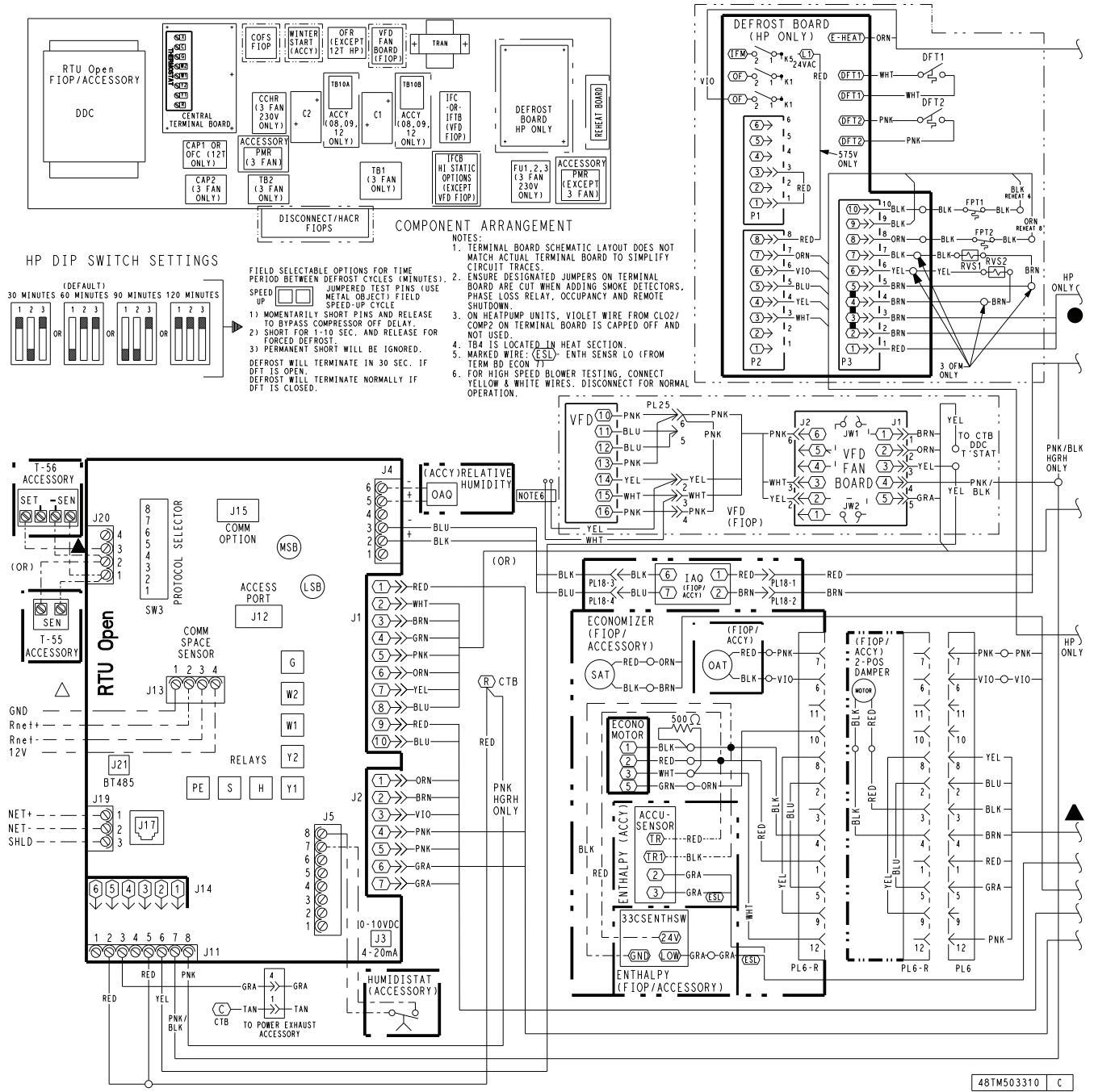
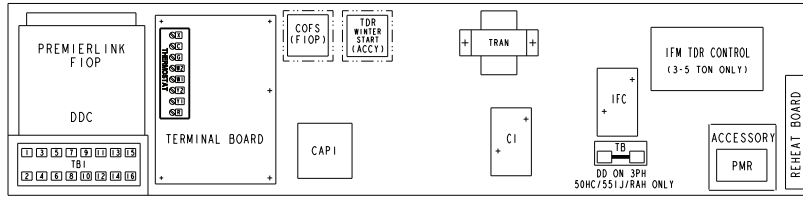

Fig. 102 - RTU-Open A07-D14 Wiring Diagram

48TM503310 C
A160181

APPENDIX IV. WIRING DIAGRAMS



COMPONENT ARRANGEMENT - (2) COMPRESSOR SHOWN

- NOTES:
1. TERMINAL BOARD SCHEMATIC LAYOUT DOES NOT MATCH ACTUAL TERMINAL BOARD TO SIMPLIFY CIRCUIT TRACES.
 2. ENSURE DESIGNATED JUMPERS ON TERMINAL BOARD ARE CUT WHEN ADDING SMOKE DETECTORS, PHASE LOSS RELAY, OCCUPANCY AND REMOTE SHUTDOWN.
 3. FOR SINGLE STAGE ELECTRIC HEAT OPTION, MOVE VIOLET HEATER WIRE FROM TB4-VIOLET WIRE TO TB4-ORANGE WIRE.
 4. TB4 IS LOCATED IN HEAT SECTION.
 5. IFC OCCURS WITHOUT DIRECT DRIVE ONLY.
 6. MARKED WIRE: ESL - ENTH SENSR LO (FROM TERM BD ECON 7)

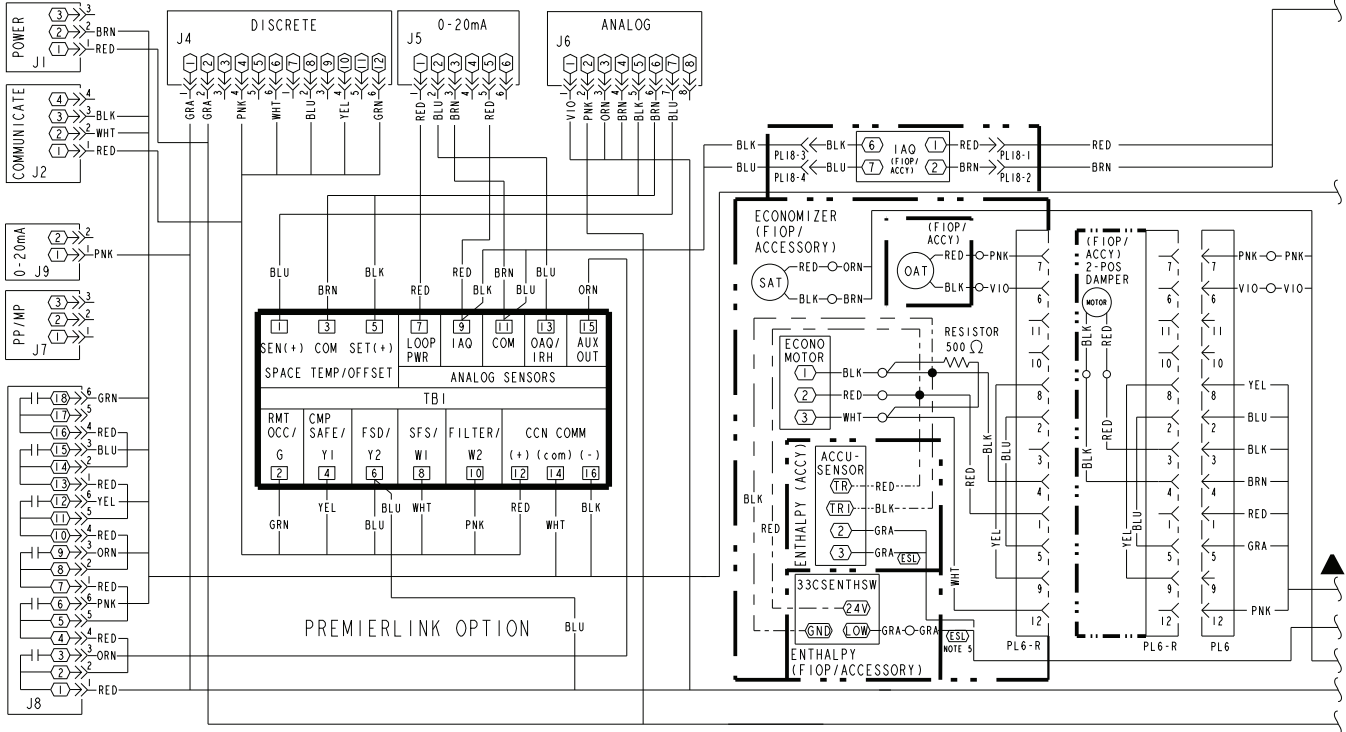
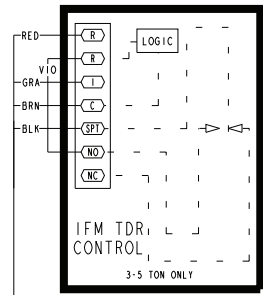

48TM500983 L

A160178

Fig. 103 - PremierLink™ System A04-A06 Wiring Diagram with Humidi-MiZer

APPENDIX IV. WIRING DIAGRAMS

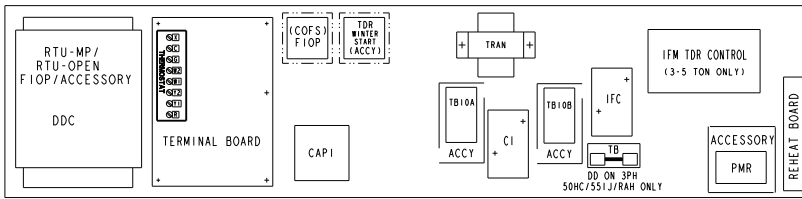

COMPONENT ARRANGEMENT - (2) COMPRESSOR SHOWN

- NOTES:
1. TERMINAL BOARD SCHEMATIC LAYOUT DOES NOT MATCH ACTUAL TERMINAL BOARD TO SIMPLIFY CIRCUIT TRACES.
 2. ENSURE DESIGNATED JUMPERS ON TERMINAL BOARD ARE CUT WHEN ADDING SMOKE DETECTORS, PHASE LOSS RELAY, OCCUPANCY AND REMOTE SHUTDOWN.
 3. FOR SINGLE STAGE ELECTRIC HEAT OPTION, MOVE VIOLET HEATER WIRE FROM TB4-VIOLET WIRE TO TB4-ORANGE WIRE.
 4. TB4 LOCATED IN HEAT SECTION.
 5. IFC OCCURS WITHOUT DIRECT DRIVE ONLY.
 6. MARKED WIRE: (ESL)- ENTH SENSR LO (FROM TERM BD ECON LO)

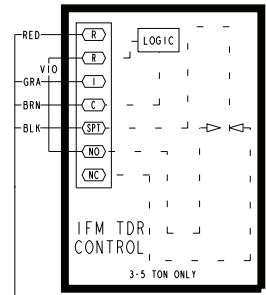

50HC

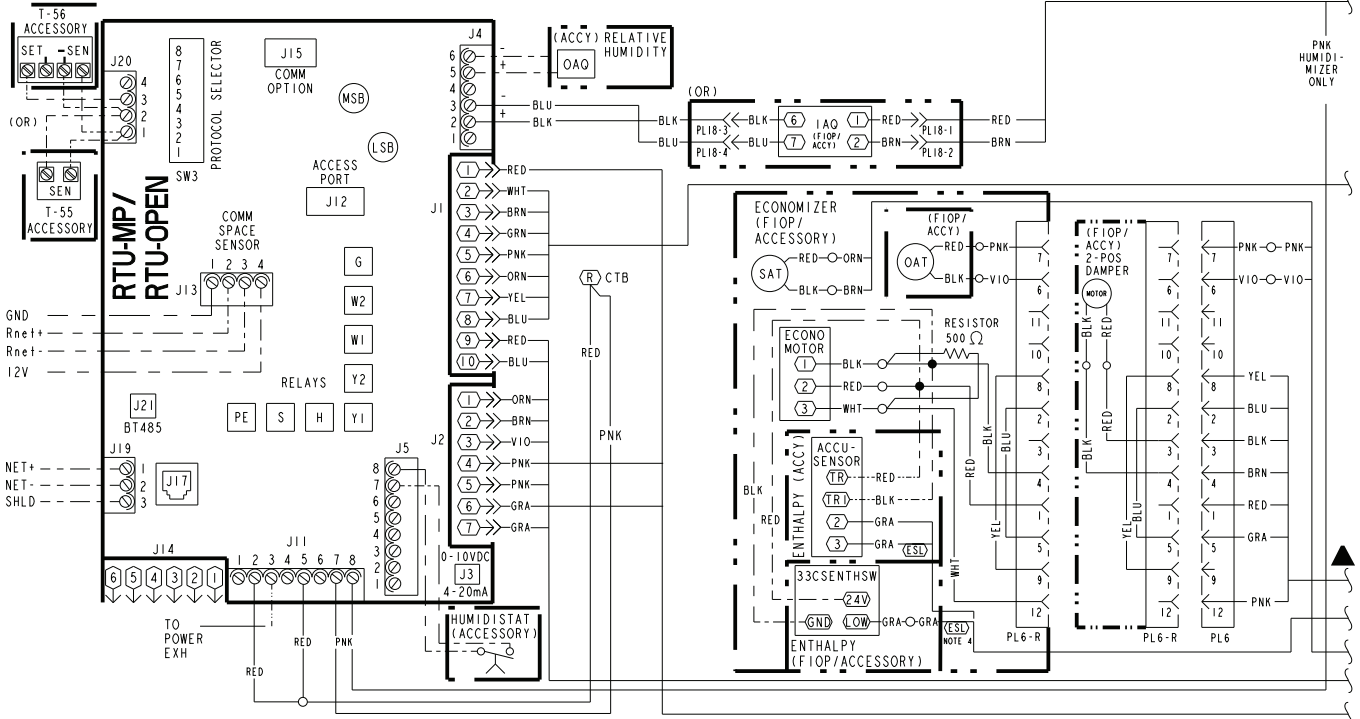

48TM502741 C

A160179

Fig. 104 - RTU Open System Control A04-A06 Wiring Diagram with Humidi-MiZer™

APPENDIX IV. WIRING DIAGRAMS

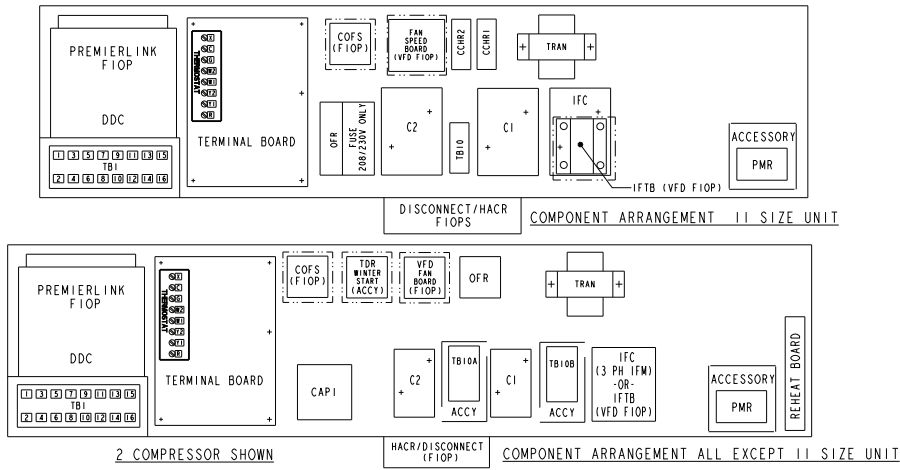

- NOTES:
1. TERMINAL BOARD SCHEMATIC LAYOUT DOES NOT MATCH ACTUAL TERMINAL BOARD TO SIMPLIFY CIRCUIT TRACES.
 2. ENSURE DESIGNATED JUMPERS ON TERMINAL BOARD ARE CUT WHEN ADDING SMOKE DETECTORS, PHASE LOSS RELAY, OCCUPANCY AND REMOTE SHUTDOWN.
 3. FOR SINGLE STAGE ELECTRIC HEAT OPTION, MOVE VIOLET HEATER WIRE FROM TB4-VIOLET WIRE TO TB4-ORANGE WIRE.
 4. TB4 IS LOCATED IN HEAT SECTION.
 5. IFC OCCURS WITHOUT DIRECT DRIVE ONLY.
 6. MARKED WIRE: (ESL)- ENTH SENSR LO (FROM TERM BD ECON 7)

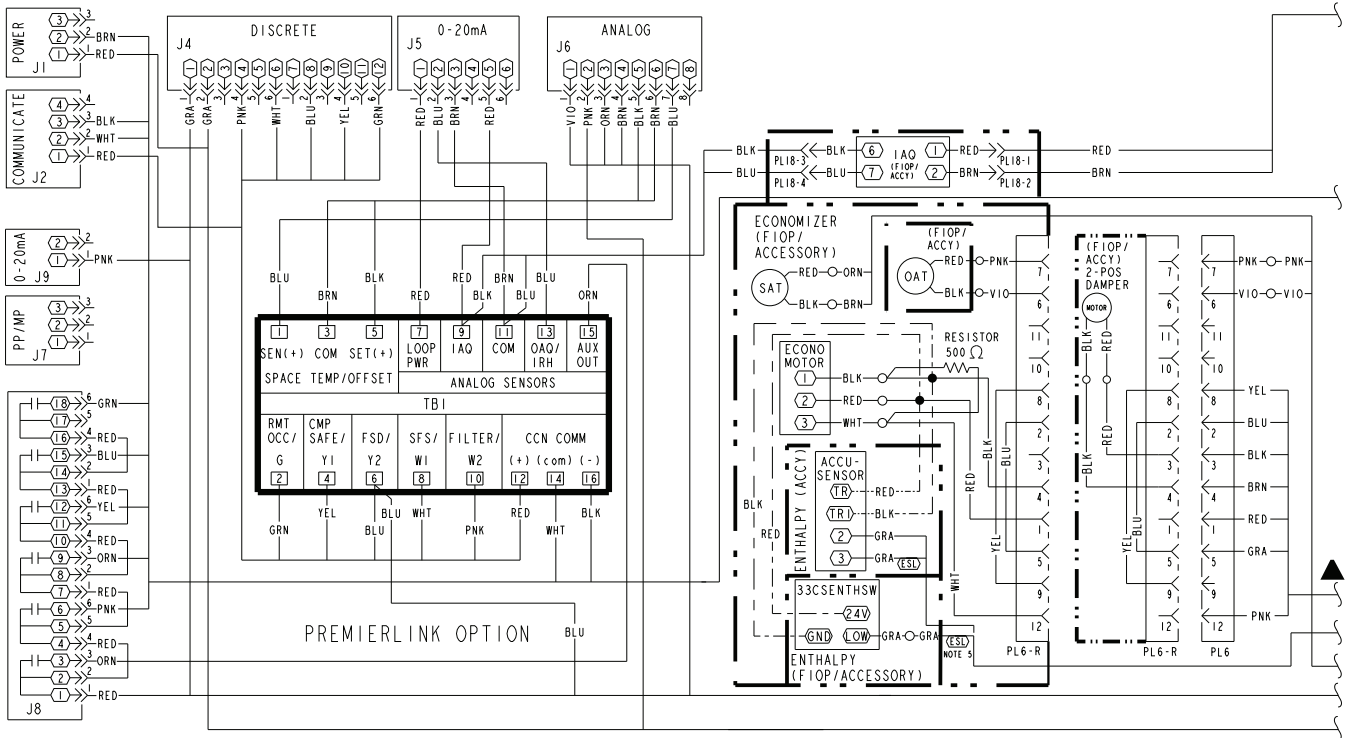

48TM504587
A160180

Fig. 105 - PremierLink™ System A07 - D14 Wiring Diagram with Humidi-MiZer™

50HC

APPENDIX IV. WIRING DIAGRAMS

50HC

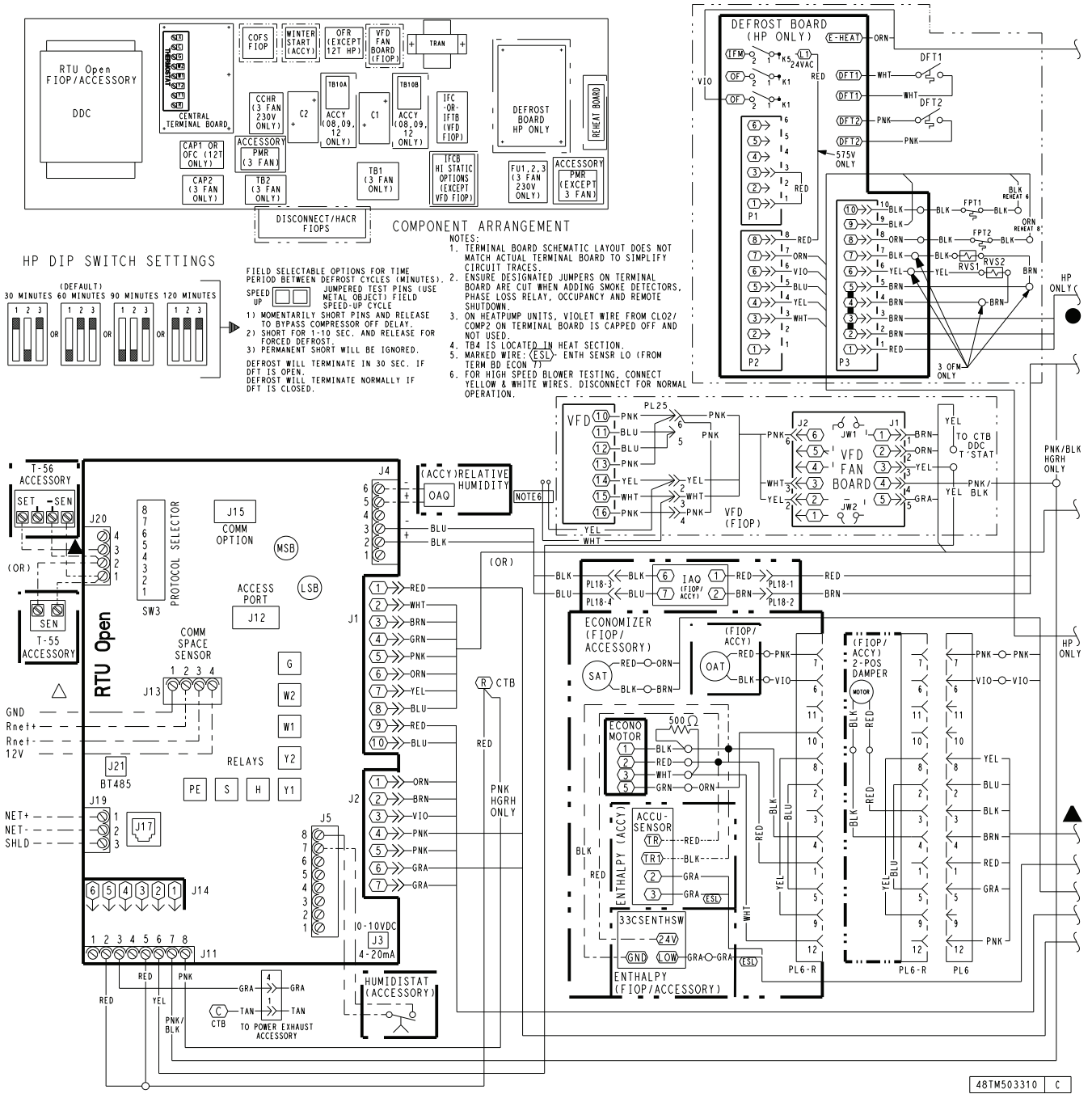
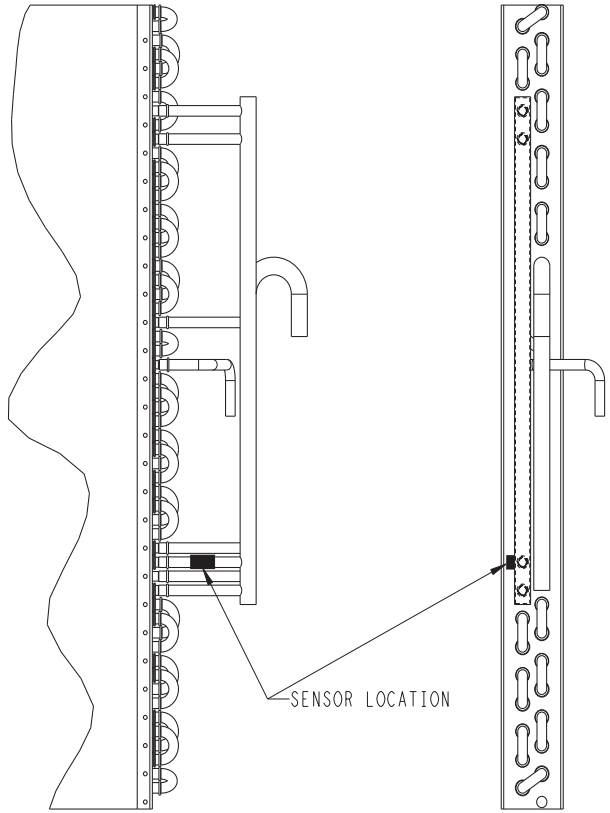

Fig. 106 - RTU-Open A07-D14 Wiring Diagram with Humidi-MiZer

APPENDIX V. MOTORMASTER SENSOR LOCATIONS



C10273

Fig. 107 - 50HC*A04 Outdoor Circuited

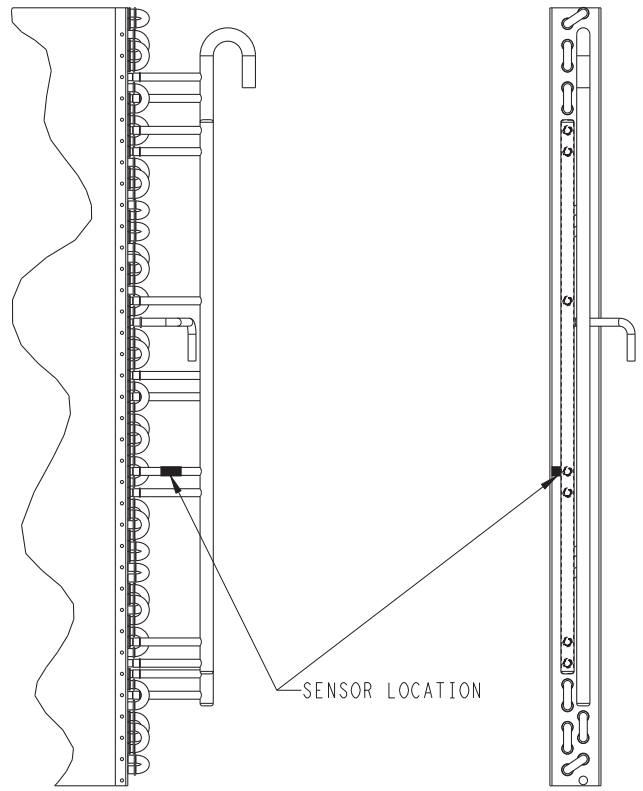

C10274

Fig. 109 - 50HC*A07 Outdoor Circuited

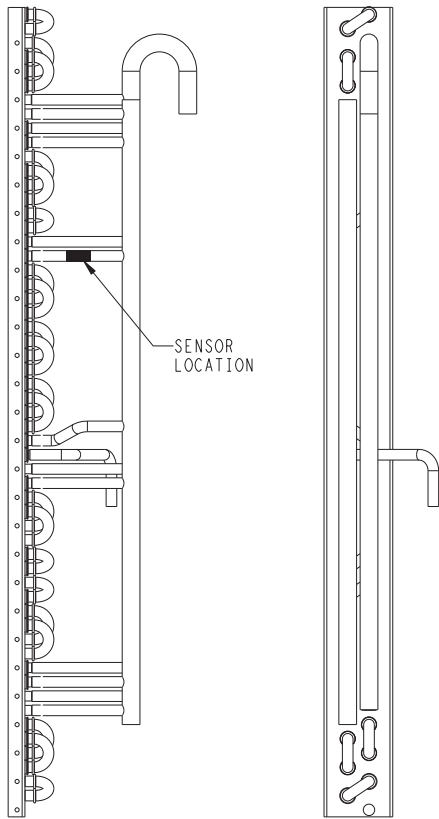

C08260

Fig. 108 - 50HC*A05/06 Outdoor Circuited

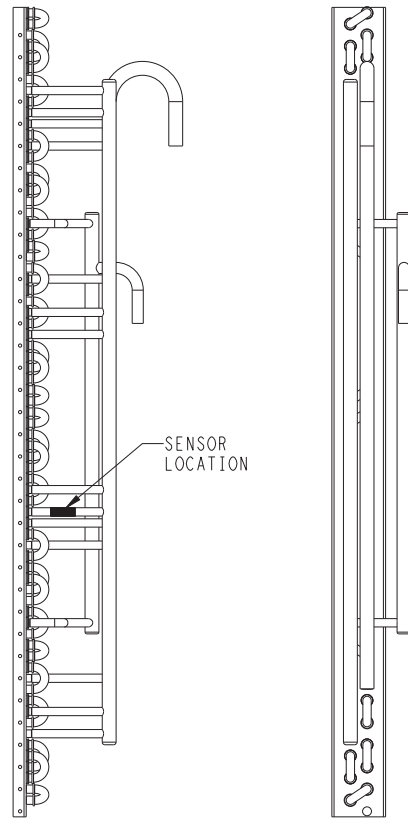

C08262

Fig. 110 - 50HC*A08 Outdoor Circuited

50HC

APPENDIX V. MOTORMASTER SENSOR LOCATIONS (cont.)

50HC

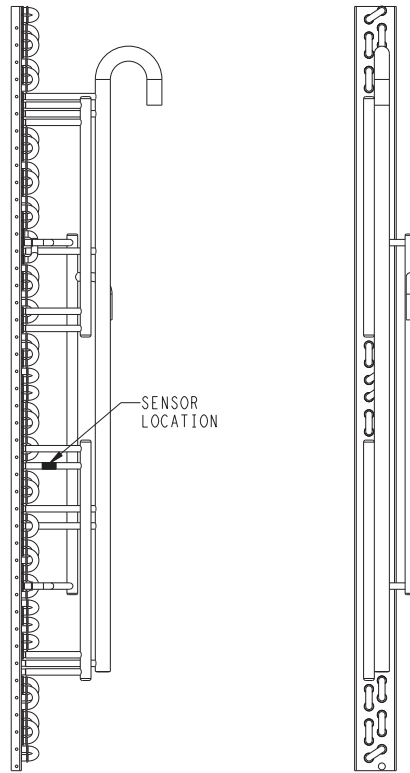

Fig. 111 - 50HC*A09 Outdoor Circuiting

C08263

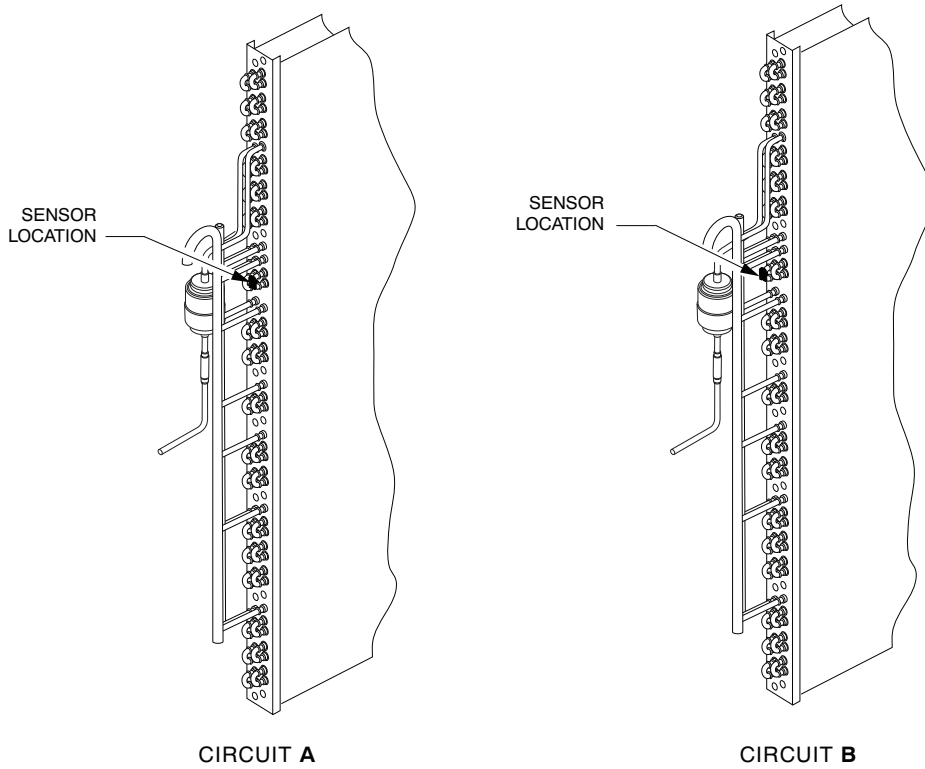

Fig. 112 - 50HC*D14 Outdoor Circuiting (Circuit A and Circuit B)

C12495

APPENDIX V. MOTORMASTER SENSOR LOCATIONS (cont.)

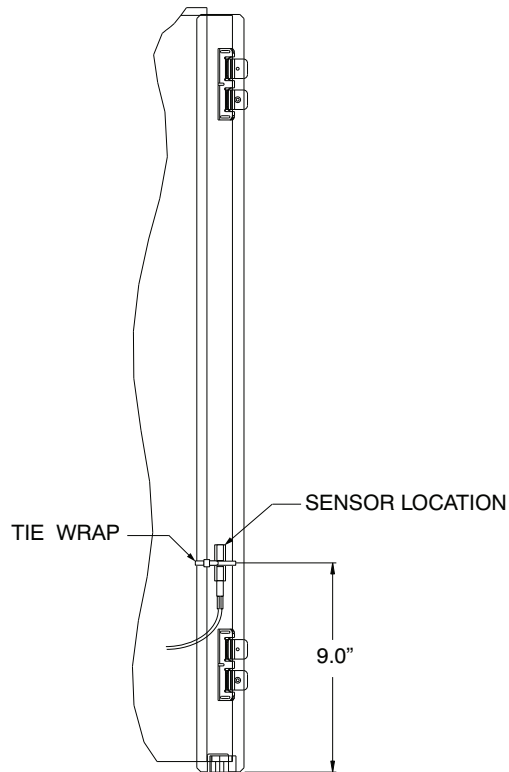

Fig. 113 - 50HC*D08 Motormaster Sensor Location - Novation Coils (MCHX)

C12492

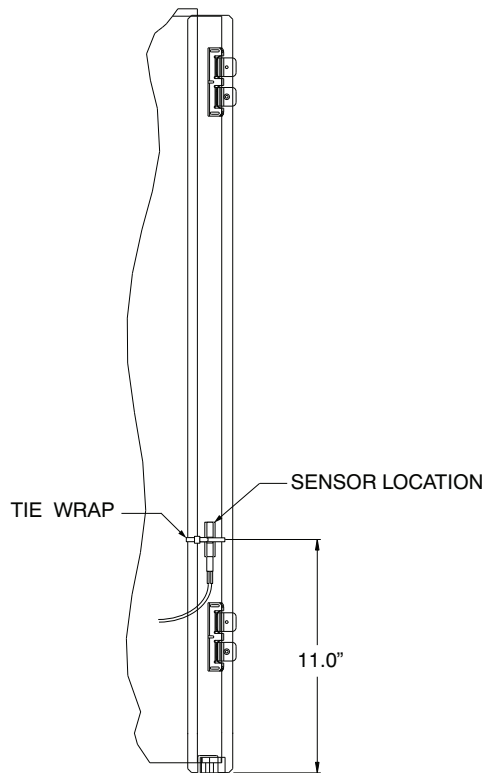

Fig. 114 - 50HC*D12 Motormaster Sensor Location - Novation Coils (MCHX)

C12493

50HC

UNIT START-UP CHECKLIST

I. PRELIMINARY INFORMATION:

MODEL NO.: _____
 DATE: _____

SERIAL NO.: _____
 TECHNICIAN: _____
 BUILDING LOCATION: _____

II. PRE-START-UP (insert check mark in box as each item is completed):

- VERIFY THAT ALL PACKAGING MATERIALS HAVE BEEN REMOVED FROM UNIT. INSPECT UNIT FOR SHIPPING AND HANDLING DAMAGE.
- VERIFY THAT CONDENSATE CONNECTION IS INSTALLED PER INSTALLATION INSTRUCTIONS. ENSURE RED CENTER PLUG IS IN PLACE IF NOT BEING USED.
- VERIFY THAT FLUE HOOD IS INSTALLED.
- CHECK ALL ELECTRICAL CONNECTIONS AND TERMINALS FOR TIGHTNESS
- CHECK TO ENSURE NO WIRES ARE TOUCHING REFRIGERANT TUBING OR SHARP EDGES
- CHECK GAS PIPING FOR LEAKS
- CHECK THAT RETURN-AIR FILTER IS CLEAN AND IN PLACE
- VERIFY THAT UNIT INSTALLATION IS LEVEL
- CHECK FAN WHEEL AND PROPELLER FOR LOCATION IN HOUSING/ORIFICE AND VERIFY SETSCREW IS TIGHT
- VERIFY PULLEY ALIGNMENT AND BELT TENSION ARE CORRECT

III. START-UP

ELECTRICAL

SUPPLY VOLTAGE	L1-L2	_____	L2-L3	_____	L3-L1	_____
COMPRESSOR AMPS	L1	_____	L2	_____	L3	_____
INDOOR FAN AMPS	L1	_____	L2	_____	L3	_____

TEMPERATURES

OUTDOOR-AIR TEMPERATURE	_____	DB	_____	WB
RETURN-AIR TEMPERATURE	_____	DB	_____	WB
COOLING SUPPLY AIR	_____	DB	_____	WB
GAS HEAT SUPPLY AIR	_____	DB	_____	

PRESSURES

GAS INLET PRESSURE	_____	IN. WG		
GAS MANIFOLD PRESSURE	_____	IN. WG (LOW FIRE)	_____	IN. WG (HI FIRE)
REFRIGERANT SUCTION	_____	PSIG	_____	TEMP °F
REFRIGERANT DISCHARGE	_____	PSIG	_____	TEMP °F

- VERIFY REFRIGERANT CHARGE USING CHARGING CHARTS
- VERIFY THAT 3-PHASE SCROLL COMPRESSOR IS ROTATING IN CORRECT DIRECTION
- VERIFY SMOKE DETECTOR PROVIDES UNIT SHUTDOWN UTILIZING MAGNET TEST.

50HC