



# Installation Instructions

NOTE: Read the entire instruction manual before starting the installation.

## CONTENTS

- SAFETY CONSIDERATIONS** ..... 1
- GENERAL** ..... 2
- Rated Indoor Airflow (cfm)** ..... 2
- INSTALLATION** ..... 9
- Jobsite Survey** ..... 9
- Step 1 — Plan for Unit Location** ..... 9
  - ROOF MOUNT
- Step 2 — Plan for Sequence of Unit Installation** .... 9
  - CURB-MOUNTED INSTALLATION
  - PAD-MOUNTED INSTALLATION
  - FRAME-MOUNTED INSTALLATION
- Step 3 — Inspect Unit** ..... 9
- Step 4 — Provide Unit Support** ..... 9
  - ROOF CURB MOUNT
  - SLAB MOUNT (HORIZONTAL UNITS ONLY)
  - ALTERNATE UNIT SUPPORT (IN LIEU OF CURB OR SLAB MOUNT)
- Step 5 — Field Fabricate Ductwork** ..... 10
- Step 6 — Rig and Place Unit** ..... 10
  - POSITIONING ON CURB
- Step 7 — Convert to Horizontal and Connect Ductwork (when required)** ..... 12
- Step 8 — Install Outside Air Hood** ..... 13
  - ECONOMIZER HOOD PACKAGE REMOVAL AND SETUP - FACTORY OPTION
  - ECONOMIZER HOOD
- Step 9 — Units with Hinged Panels Only** ..... 14
- Step 10 — Install External Condensate Trap and Line** ..... 14
- Step 11 — Make Electrical Connections** ..... 15
  - FIELD POWER SUPPLY
  - UNITS WITH FACTORY-INSTALLED NON-FUSED DISCONNECT OR HACR
  - TO FIELD-INSTALL THE NFD SHAFT AND HANDLE
  - TO FIELD-INSTALL THE HACR SHAFT AND HANDLE
  - UNITS WITHOUT FACTORY-INSTALLED DISCONNECT OR HACR
  - ALL UNITS
  - CONVENIENCE OUTLETS
  - HACR
  - FACTORY-OPTION THRU-BASE CONNECTIONS


- UNITS WITHOUT THRU-BASE CONNECTIONS
- FIELD CONTROL WIRING
- THERMOSTAT
- UNIT WITHOUT THRU-BASE CONNECTION KIT
- HEAT ANTICIPATOR SETTINGS
- Electric Heaters** ..... 26
  - SINGLE POINT BOXES AND SUPPLEMENTARY FUSES
  - SINGLE POINT BOXES WITHOUT FUSES
  - LOW-VOLTAGE CONTROL CONNECTIONS
- Humidi-MiZer® Control Connections** ..... 28
  - HUMIDI-MIZER – SPACE RH CONTROLLER
- EconoMi\$er X (Factory-Installed Option)** ..... 28
- SystemVu™ Controller (Factory-Installed Option)** ..... 28
- RTU Open Control System** ..... 28
- Smoke Detectors** ..... 32
- Step 12 — Adjust Factory-Installed Options** ..... 33
- Step 13 — Install Accessories** ..... 33
- Step 14 — Check Belt Tension** ..... 33
- Pre-Start and Start-Up** ..... 33
- APPENDIX A — VFD OPERATION WITH REMOTE KEYPAD** ..... 34
- START-UP CHECKLIST** ..... CL-1

## SAFETY CONSIDERATIONS

Installation and servicing of air-conditioning equipment can be hazardous due to system pressure and electrical components. Only trained and qualified service personnel should install, repair, or service air-conditioning equipment.

Untrained personnel can perform basic maintenance functions of cleaning coils and filters and replacing filters. All other operations should be performed by trained service personnel. When working on air-conditioning equipment, observe precautions in the literature, tags and labels attached to the unit, and other safety precautions that may apply.

Follow all safety codes, including ANSI (American National Standards Institute) Z223.1. Wear safety glasses and work gloves. Use quenching cloth for unbrazing operations. Have fire extinguisher available for all brazing operations.

It is important to recognize safety information. This is the safety-alert symbol . When you see this symbol on the unit and in instructions or manuals, be alert to the potential for personal injury.

Understand the signal words DANGER, WARNING, CAUTION, and NOTE. These words are used with the safety-alert symbol. DANGER identifies the most serious hazards which **will** result in severe personal injury or death. WARNING signifies hazards which **could** result in personal injury or death. CAUTION is used to identify unsafe practices, which **may** result in minor personal injury or product and property damage. NOTE is used to highlight

suggestions which **will** result in enhanced installation, reliability, or operation.

**⚠ WARNING**

**ELECTRICAL SHOCK HAZARD**

Failure to follow this warning could cause personal injury or death.

Before performing service or maintenance operations on unit, turn off main power switch to unit and install lock(s) and lock-out tag(s). Ensure electrical service to rooftop unit agrees with voltage and amperage listed on the unit rating plate. Unit may have more than one power switch.

**⚠ WARNING**

**UNIT OPERATION AND SAFETY HAZARD**

Failure to follow this warning could cause personal injury, death and/or equipment damage.

Puron® (R-410A) refrigerant systems operate at higher pressures than standard R-22 systems. Do not use R-22 service equipment or components on Puron refrigerant equipment.

**⚠ WARNING**

**PERSONAL INJURY AND ENVIRONMENTAL HAZARD**

Failure to follow this warning could cause personal injury or death.

Relieve pressure and recover all refrigerant before system repair or final unit disposal.

Wear safety glasses and gloves when handling refrigerants. Keep torches and other ignition sources away from refrigerants and oils.

**⚠ CAUTION**

**CUT HAZARD**

Failure to follow this caution may result in personal injury.

Sheet metal parts may have sharp edges or burrs. Use care and wear appropriate protective clothing, safety glasses and gloves when handling parts and servicing air conditioning equipment.

**GENERAL**

See Fig. 1 for unit options. See Fig. 2 and 3 for unit dimensions. See Fig. 4 for corner weights and clearances. See Fig. 5 for base rail details. See Fig. 6 for thru-the-base charts.

**Rated Indoor Airflow (cfm)**

Table 1 lists the rated indoor airflow used for the AHRI efficiency rating for the units covered in this document.

**Table 1 — Rated Indoor Airflow (cfm)**

MODEL NUMBER	FULL LOAD AIRFLOW (CFM)
50LC**04	1050
50LC**05	1400
50LC**06	1750

Position:	1	2	3	4	5	6	7	8	9	10	11	12	13	14	15	16	17	18
Example:	5	0	L	C	D	0	0	6	A	0	A	5	-	0	A	0	A	0

**Unit Heat Type**

50 - Electric Cooling/Heating  
Packaged Rooftop

**Model Series - WeatherExpert®**

LC - Ultra High Efficiency

**Heat Options**

0 = Standard, No Electric Heat  
D = Low Electric Heat  
E = Medium Electric Heat  
F = High Electric Heat

**Refrig. Systems Options**

0 = Two stage cooling capacity  
A = Two stage cooling capacity  
with Humidi-MiZer® System

**Cooling Tons**

04 - 3 ton  
05 - 4 ton  
06 - 5 ton

**Sensor Options**

A = None  
B = RA Smoke Detector  
C = SA Smoke Detector  
D = RA + SA Smoke Detector  
E = CO<sub>2</sub>  
F = RA Smoke Detector and CO<sub>2</sub>  
G = SA Smoke Detector and CO<sub>2</sub>  
H = RA + SA Smoke Detector and CO<sub>2</sub>

**Indoor Fan Options**

0 = Standard Electrical (Direct) Drive x13 ECM Motor  
2 = Medium Static Belt Drive with VFD controller  
3 = High Static Belt Drive with VFD controller

**Coil Options: Fin/Tube (Condenser- Evaporator - Hail Guard)**

A = Al/Cu - Al/Cu  
B = Precoat Al/Cu - Al/Cu  
C = E-coat Al/Cu - Al/Cu  
D = E-coat Al/Cu - E-coat Al/Cu  
E = Cu/Cu - Al/Cu  
F = Cu/Cu - Cu/Cu  
M = Al/Cu -Al/Cu — Louvered Hail Guard  
N = Precoat Al/Cu - Al/Cu — Louvered Hail Guard  
P = E-coat Al/Cu - Al/Cu — Louvered Hail Guard  
Q = E-coat Al/Cu - E-coat Al/Cu — Louvered Hail Guard  
R = Cu/Cu - Al/Cu — Louvered Hail Guard  
S = Cu/Cu - Cu/Cu — Louvered Hail Guard

**Packaging**

0 = Standard  
1 = LTL

**Electrical Options**

A = None  
B = HACR Circuit Breaker  
C = Non-Fused Disconnect  
D = Thru-The-Base Connections  
E = HACR Circuit Breaker  
and Thru-The Base Connections  
F = Non-Fused Disconnect and  
Thru-The-Base Connections

**Service Options**

0 = None  
1 = Unpowered Convenience Outlet  
2 = Powered Convenience Outlet  
3 = Hinged Panels  
4 = Hinged Panels and  
Unpowered Convenience Outlet  
5 = Hinged Panels and  
Powered Convenience Outlet

**Air Intake / Exhaust Options**

A = None  
B = Temperature Economizer with Barometric Relief  
E = Enthalpy Economizer with Barometric Relief  
N = Ultra Low Leak Temperature Economizer  
with Barometric Relief  
R = Ultra Low Leak Enthalpy Economizer with  
Barometric Relief

**Base Unit Controls**

0 = Base Electromechanical Controls  
1 = RTU Open Multi-Protocol Controller  
4 = SystemVu™ Controller

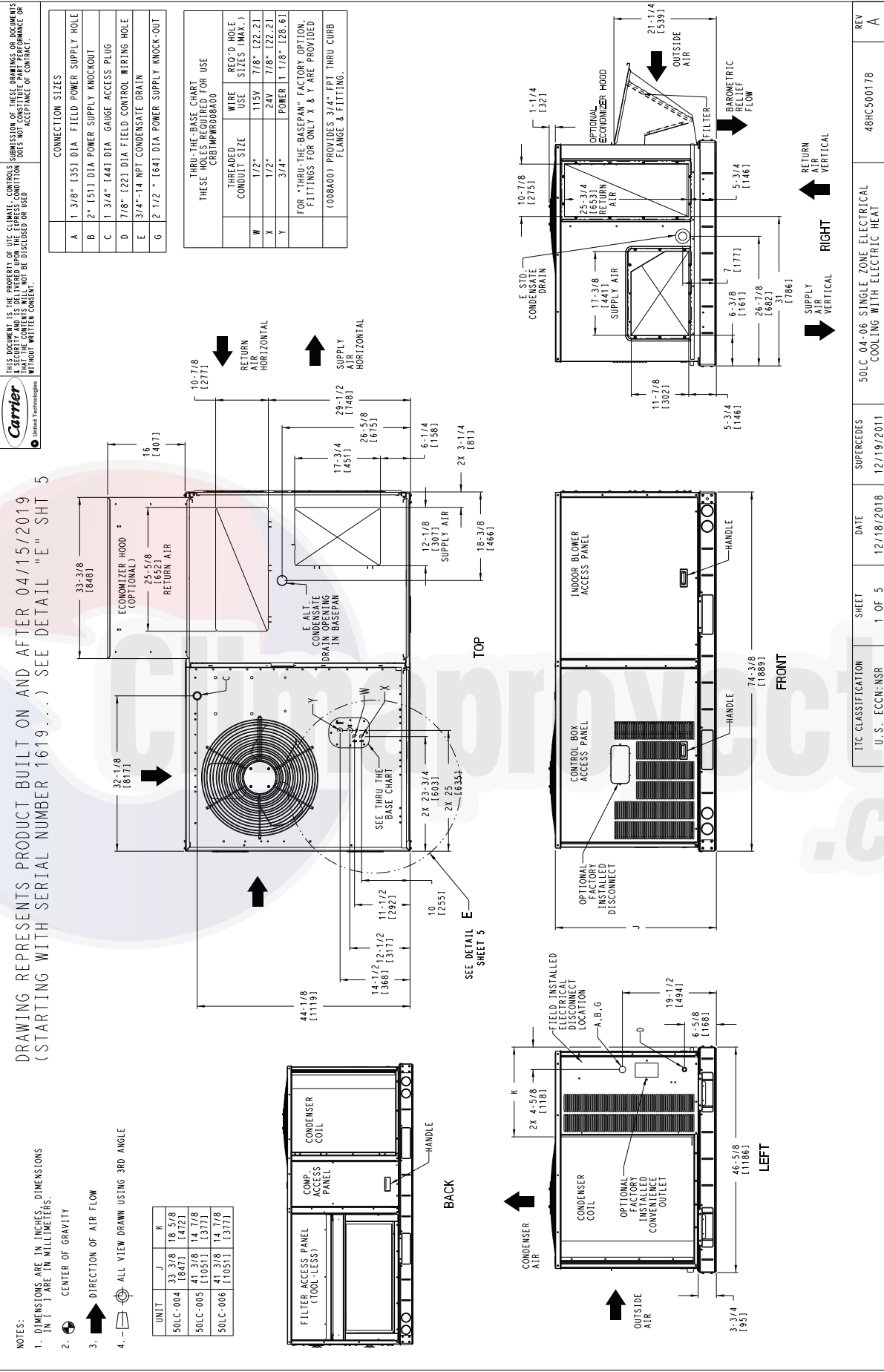
**Design Revision**

- = Factory Design Revision

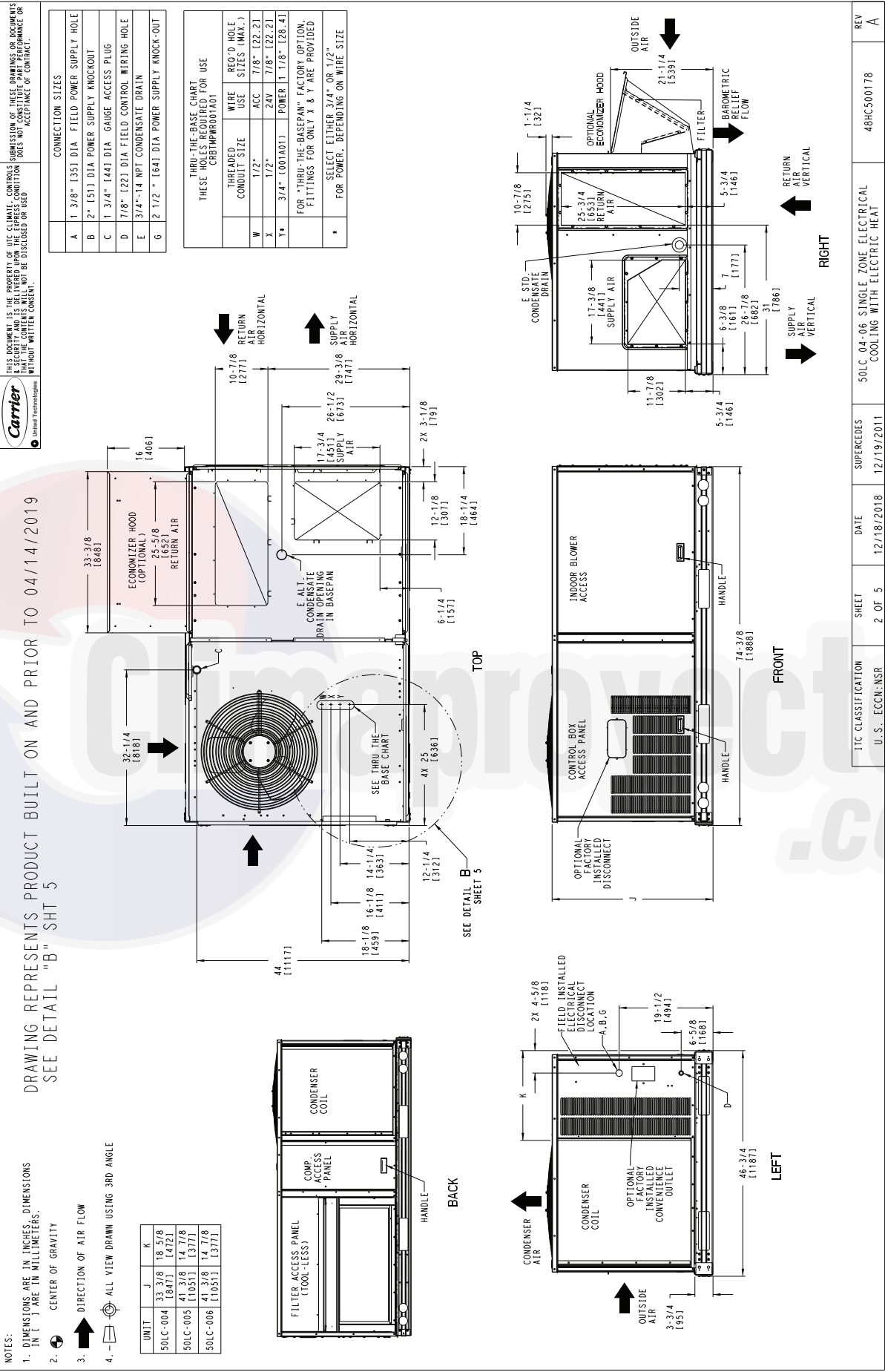
**Voltage**

1 = 575/3/60  
5 = 208-230/3/60  
6 = 460/3/60

**Fig. 1 — 50LC 04-06 Model Number Nomenclature**



**Fig. 2 — Dimensional Drawing for Units Built On and After 4/15/19**

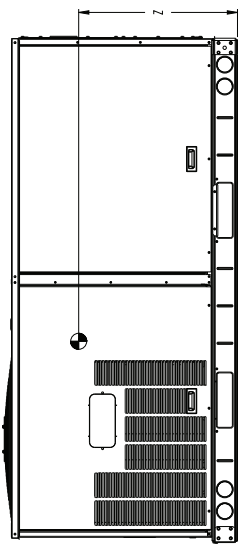
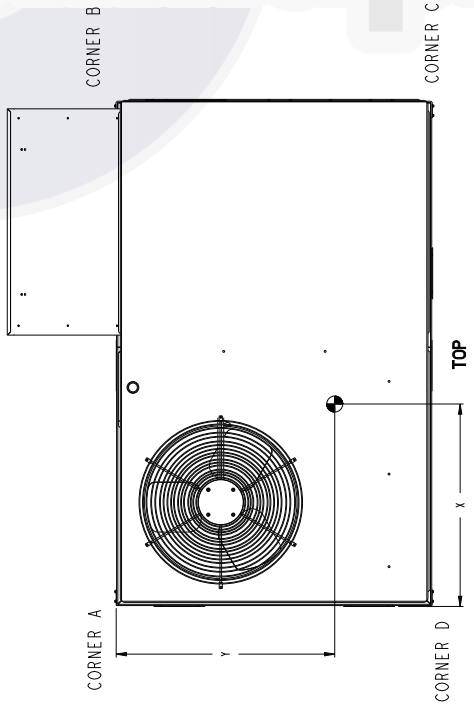
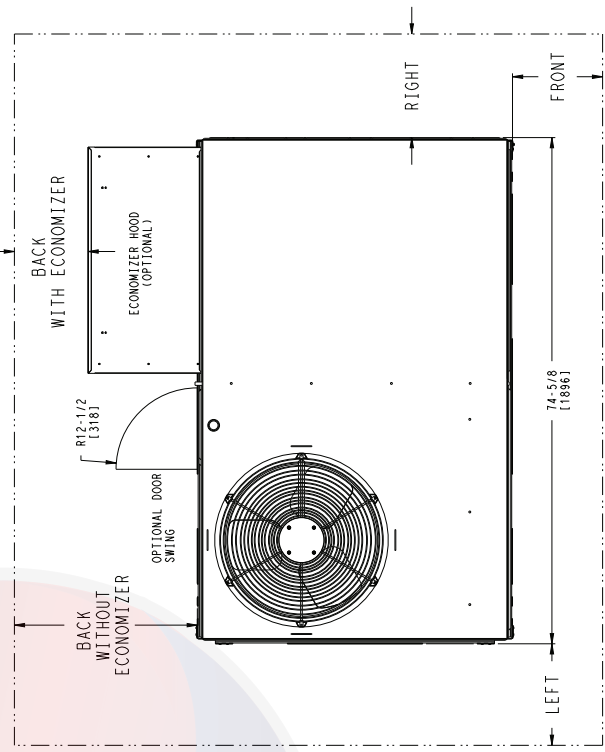


**Fig. 3 — Dimension Drawing for Units Built Prior to 4/15/19**

ITC CLASSIFICATION U.S. ECCN: NSR	SHEET 2 OF 5	DATE 12/18/2018	SUPERCEDES 12/19/2011	50LC 04-06 SINGLE ZONE ELECTRICAL COOLING WITH ELECTRIC HEAT	REV A
--------------------------------------	-----------------	--------------------	--------------------------	--	----------

UNIT	STD. UNIT WEIGHT		CORNER WEIGHT (A)		CORNER WEIGHT (B)		CORNER WEIGHT (C)		CORNER WEIGHT (D)		C. G.			HEIGHT	
	LBS.	KG.	LBS.	KG.	LBS.	KG.	LBS.	KG.	LBS.	KG.	X	Y	Z	19 3/4 [502]	20 1/8 [530]
50LC-004	438	208	128	58	109	49	101	46	120	54	34 1/8 [867]	22 1/2 [572]	19 3/4 [502]		
50LC-005	545	247	156	71	135	61	118	54	136	62	34 5/8 [879]	21 3/4 [552]	20 1/8 [530]		
50LC-006	550	249	160	73	136	62	117	53	138	63	34 1/8 [867]	21 5/8 [549]	20 1/4 [514]		

\* - STANDARD UNIT WEIGHT IS WITHOUT ELECTRIC HEAT AND WITHOUT PACKAGING.  
 \*\* - STANDARD UNIT WEIGHT IS WITHOUT ELECTRIC HEAT AND WITHOUT PACKAGING.  
 FOR OTHER OPTIONS AND ACCESSORIES REFER TO THE PRODUCT DATA CATALOG.



NOTE:  
 1. FOR ALL MINIMUM CLEARANCES LOCAL CODES OR JURISDICTIONS MAY PREVAIL.

SURFACE	CLEARANCE		
	SERVICE WITH CONDUCTIVE BARRIER	SERVICE WITH NONCONDUCTIVE BARRIER	OPERATING CLEARANCE
FRONT	48 [1219mm]	36 [914mm]	18 [457mm]
LEFT	48 [1219mm]	42 [1067mm]	18 [457mm]
BACK W/O ECON	48 [1219mm]	42 [1067mm]	18 [457mm]
BACK W/ECON	36 [914mm]	36 [914mm]	18 [457mm]
RIGHT	36 [914mm]	36 [914mm]	18 [457mm]
TOP	72 [1829mm]	72 [1829mm]	72 [1829mm]

ITC CLASSIFICATION	SHEET	DATE	REV
U.S. ECCN-NSR	3 OF 5	12/18/2018	48HC500178
50LC 04-06 SINGLE ZONE ELECTRICAL COOLING WITH ELECTRIC HEAT		12/19/2011	A

Fig. 4 — Corner Weights and Clearances

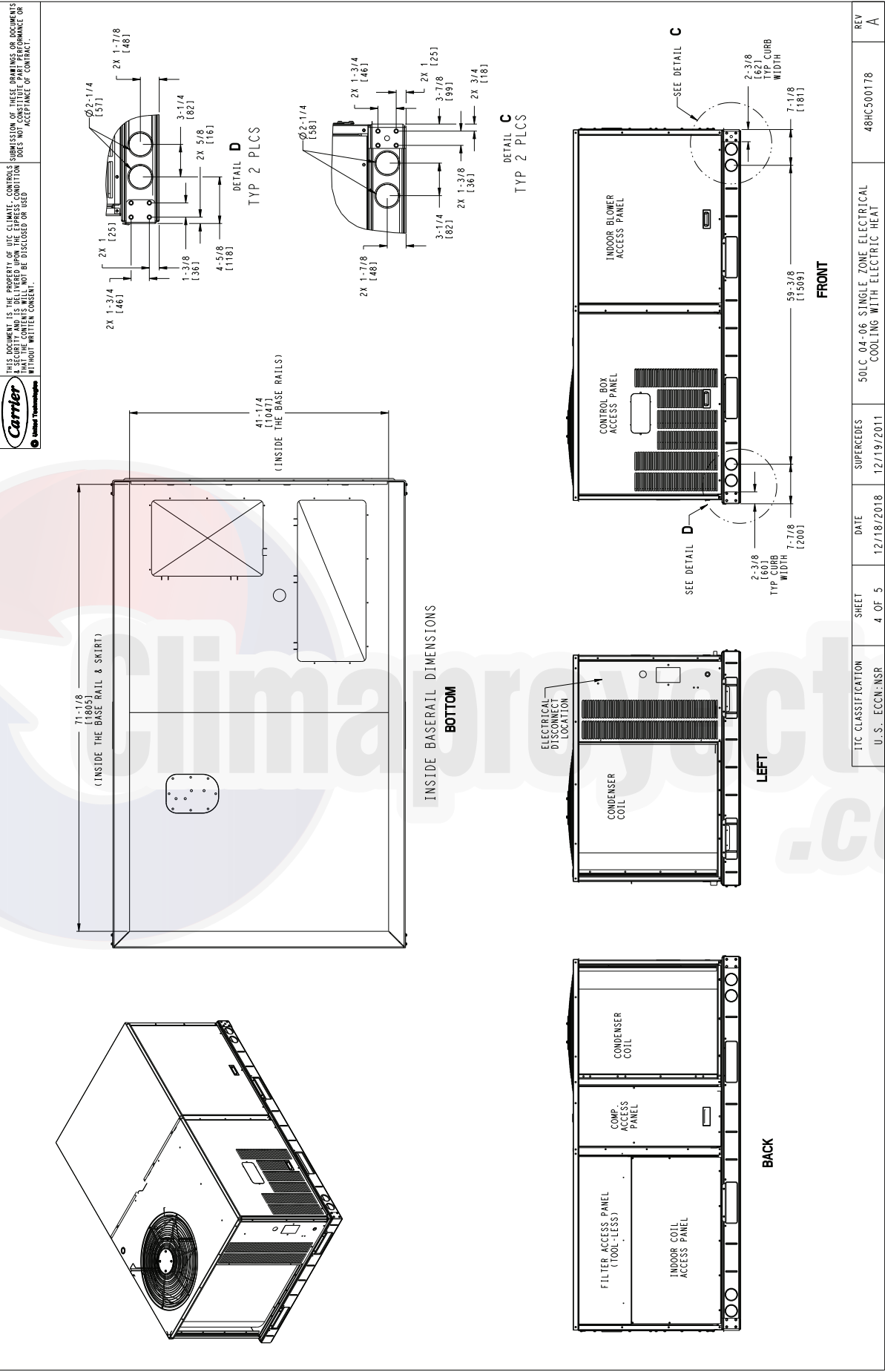


Fig. 5 — Base Rail Details



THRU-THE-BASE CHART CDB1MPR001A01		
THREADED CONDUIT SIZE	WIRE USE	REC'D HOLE SIZES (MAX.)
W 1/2"	ACC	7/8" [22.2]
X 1/2"	24V	7/8" [22.2]
Y 3/4"	POWER	1 1/8" [28.4]

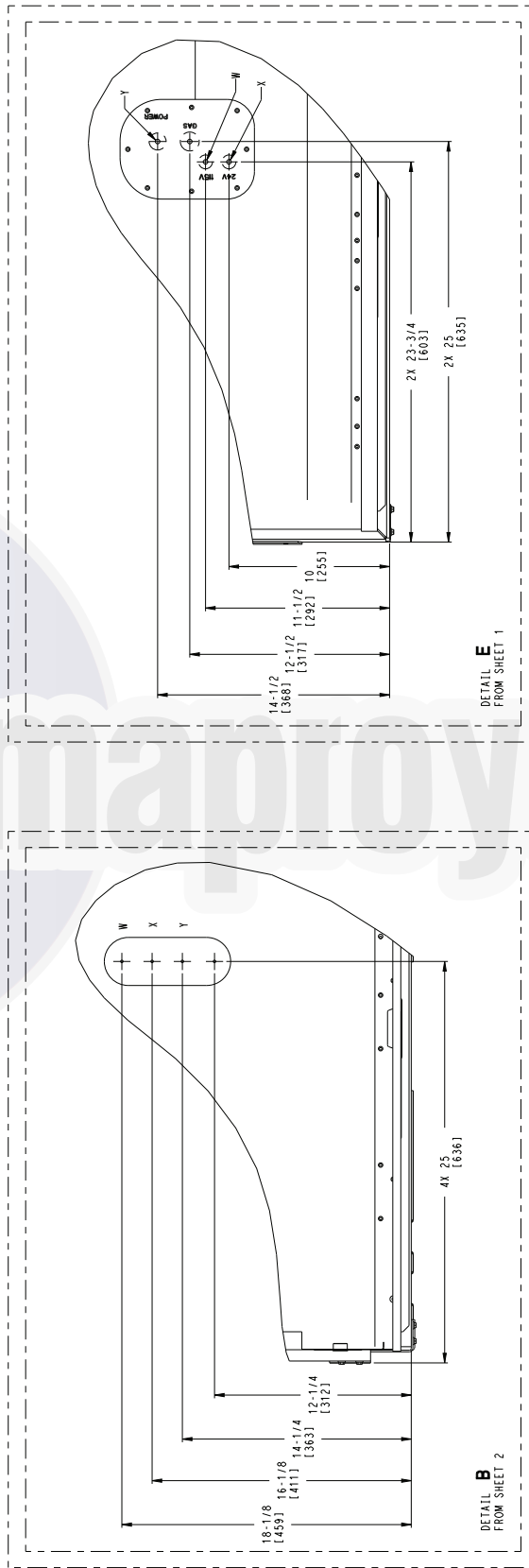
FOR "THRU-THE-BASEPAN" FACTORY OPTION, FITTINGS FOR ONLY X & Y ARE PROVIDED

SELECT EITHER 3/4" OR 1/2" FOR POWER, DEPENDING ON WIRE SIZE

THRU-THE-BASE CHART CDB1MPR008A00		
THREADED CONDUIT SIZE	WIRE USE	REC'D HOLE SIZES (MAX.)
W 1/2"	115V	7/8" [22.2]
X 1/2"	24V	7/8" [22.2]
Y 3/4"	POWER	1 1/8" [28.6]

FOR "THRU-THE-BASEPAN" FACTORY OPTION, FITTINGS FOR ONLY X & Y ARE PROVIDED

(008A00) PROVIDES 3/4" FPT THRU CURB FLANGE & FITTING.



THIS VIEW REPRESENTS PRODUCT BUILT ON AND PRIOR TO 04/14/2019 THIS VIEW REPRESENTS PRODUCT BUILT ON AND AFTER 04/15/2019

ITC CLASSIFICATION U.S. ECCN-NSR	SHEET 5 OF 5	DATE 12/18/2018	SUPERCEDES 12/19/2011	50LC 04-06 SINGLE ZONE ELECTRICAL COOLING WITH ELECTRIC HEAT	REV A
-------------------------------------	-----------------	--------------------	--------------------------	--	----------

Fig. 6 — Thru-the-Base Charts



## INSTALLATION

### Jobsite Survey

Complete the following checks before installation:

1. Consult local building codes and the NEC (National Electrical Code) ANSI/NFPA 70 for special installation requirements.
2. Determine unit location (from project plans) or select unit location.
3. Check for possible overhead obstructions which may interfere with unit lifting or rigging.

### Step 1 — Plan for Unit Location

Select a location for the unit and its support system (curb or other) that provides for minimum clearances required for safety (including clearance to combustible surfaces), unit performance and service access below and around unit as specified in Fig. 4.

NOTE: Consider also the effect of adjacent units.

Unit may be installed directly on wood flooring or on Class A, B, or C roof-covering material when roof curb is used.

Do not install unit in an indoor location. Do not locate air inlets near exhaust vents or other sources of contaminated air.

Although unit is weatherproof, avoid locations that permit water from higher level runoff and overhangs to fall onto unit.

Select a unit mounting system that provides adequate height to allow installation of condensate trap per requirements. Refer to “Install External Condensate Trap and Line” on page 14 – for required trap dimensions.

#### ROOF MOUNT

Check building codes for weight distribution requirements. Unit operating weight is shown in Table 2.

### Step 2 — Plan for Sequence of Unit Installation

The support method used for this unit will dictate different sequences for the steps of unit installation. For example, on curb-mounted units, some accessories must be installed on the unit before the unit is placed on the curb. Review the following for recommended sequences for installation steps.

#### CURB-MOUNTED INSTALLATION

1. Install curb.
2. Install field-fabricated ductwork inside curb.
3. Install accessory thru-base service connection package (affects curb and unit) (refer to accessory installation instructions for details).
4. Prepare bottom condensate drain connection to suit planned condensate line routing (refer to “Install External Condensate Trap and Line” on page 14 for details).
5. Rig and place unit.
6. Install outdoor air hood.
7. Install condensate line trap and piping.
8. Make electrical connections.
9. Install other accessories.

Table 2 — Operating Weights

50LC-*	UNITS LB (KG)		
	04	05	06
Base Unit	458 (208)	545 (247)	550 (249)
Economizer			
Vertical	50 (23)	50 (23)	50 (23)
Horizontal	80 (36)	80 (36)	80 (36)
Humidi-MiZer® System	50 (23)	55 (25)	55 (25)
Cu Fins	25 (11)	43 (20)	56 (25)
Powered Outlet	35 (16)	35 (16)	35 (16)
Curb			
14-in./356 mm	115 (52)	115 (52)	115 (52)
24-in./610 mm	197 (89)	197 (89)	197 (89)

#### PAD-MOUNTED INSTALLATION

1. Prepare pad and unit supports.
2. Check and tighten the bottom condensate drain connection plug.
3. Rig and place unit.
4. Convert unit to side duct connection arrangement.
5. Install field-fabricated ductwork at unit duct openings.
6. Install outdoor air hood.
7. Install condensate line trap and piping.
8. Make electrical connections.
9. Install other accessories.

#### FRAME-MOUNTED INSTALLATION

Frame-mounted applications generally follow the sequence for a curb installation. Adapt as required to suit specific installation plan.

### Step 3 — Inspect Unit

Inspect unit for transportation damage. File any claim with transportation agency.

Confirm before installation of unit that voltage, amperage and circuit protection requirements listed on unit data plate agree with power supply provided.

On units with hinged panel option, check to be sure all latches are snug and in closed position.

Locate the carton containing the outside air hood parts; see Fig. ?. Do not remove carton until unit has been rigged and located in final position.

### Step 4 — Provide Unit Support

#### ROOF CURB MOUNT

Accessory roof curb details and dimensions are shown in Fig. 8. Assemble and install accessory roof curb in accordance with instructions shipped with the curb.

Curb should be level. This is necessary for unit drain to function properly. Unit leveling tolerances are shown in Fig. 7. Refer to Accessory Roof Curb Installation Instructions for additional information as required.

Install insulation, cant strips, roofing felt, and counter flashing as shown. *Ductwork must be attached to curb and not to the unit. The accessory thru-the-base power and gas connection package must be installed before the unit is set on the roof curb.*

If electric and control wiring is to be routed through the basepan, attach the accessory thru-the-base service connections to the basepan in accordance with the accessory installation instructions.

NOTE: The gasketing of the unit to the roof curb is critical for a watertight seal. Install gasket supplied with the roof curb as shown in Fig. 8. Improperly applied gasket can also result in air leaks and poor unit performance.

### SLAB MOUNT (HORIZONTAL UNITS ONLY)

Provide a level concrete slab that extends a minimum of 6-in. (150 mm) beyond unit cabinet. Install a gravel apron in front of condenser coil air inlet to prevent grass and foliage from obstructing airflow.

NOTE: Horizontal units may be installed on a roof curb if required.

### ALTERNATE UNIT SUPPORT (IN LIEU OF CURB OR SLAB MOUNT)

A non-combustible sleeper rail can be used in the unit curb support area. If sleeper rails cannot be used, support the long sides of the unit with a minimum of 3 equally spaced 4-in. x 4-in. (102 mm x 102 mm) pads on each side.

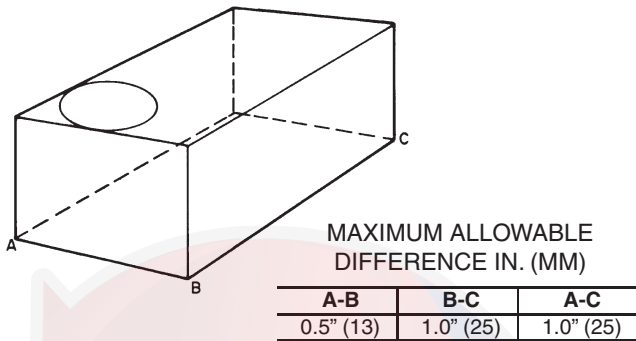


Fig. 7 — Unit Leveling Tolerances

### Step 5 — Field Fabricate Ductwork

Cabinet return-air static pressure (a negative condition) shall not exceed 0.35 in. wg (87 Pa) with economizer or 0.45 in. wg (112 Pa) without economizer.

For vertical ducted applications, secure all ducts to roof curb and building structure. *Do not connect ductwork to unit.*

Fabricate supply ductwork so that the cross sectional dimensions are equal to or greater than the unit supply duct opening dimensions for the first 18-in. (458 mm) of duct length from the unit basepan.

Insulate and weatherproof all external ductwork, joints, and roof openings with counter flashing and mastic in accordance with applicable codes.

Ducts passing through unconditioned spaces must be insulated and covered with a vapor barrier.

If a plenum return is used on a vertical unit, the return should be ducted through the roof deck to comply with applicable fire codes.

#### ⚠ CAUTION

##### PROPERTY DAMAGE HAZARD

Failure to follow this caution may result in damage to roofing materials.

Membrane roofs can be cut by sharp sheet metal edges. Be careful when placing any sheet metal parts on such roof.

### FOR UNITS WITH ACCESSORY OR OPTIONAL ELECTRIC HEATERS

All installations require a minimum clearance to combustible surfaces of 1-in. (25 mm) from duct for first 12-in. (305 mm) away from unit.

Outlet grilles must not lie directly below unit discharge.

NOTE: A 90 degree elbow must be provided in the ductwork to comply with UL (Underwriters Laboratories) code for use with electric heat.

#### ⚠ WARNING

##### PERSONAL INJURY HAZARD

Failure to follow this warning could cause personal injury.

For vertical supply and return units, tools or parts could drop into ductwork and cause an injury. Install a 90 degree turn in the return ductwork between the unit and the conditioned space. If a 90 degree elbow cannot be installed, then a grille of sufficient strength and density should be installed to prevent objects from falling into the conditioned space. Due to electric heater, supply duct will require 90 degree elbow.

### Step 6 — Rig and Place Unit

Keep unit upright and do not drop. Spreader bars are required. Rollers may be used to move unit across a roof. Level by using unit frame as a reference. See Table 2 and Fig. 9 for additional information.

Lifting holes are provided in base rails as shown in Fig. 9. Refer to rigging instructions on unit.

Before setting the unit onto the curb, recheck gasketing on curb.

Rigging materials under unit (cardboard or wood) must be removed PRIOR to placing the unit on the roof curb.

When using the standard side drain connection, ensure the red plug in the alternate bottom connection is tight. Do this before setting the unit in place. The red drain pan plug can be tightened with a 1/2-in. square socket drive extension. For further details see "Install External Condensate Trap and Line" on page 14.

#### ⚠ CAUTION

##### UNIT DAMAGE HAZARD

Failure to follow this caution may result in equipment damage.

All panels must be in place when rigging. Unit is not designed for handling by fork truck when packaging is removed.

If using top crate as spreader bar, once unit is set, carefully lower wooden crate off building roof top to ground. Ensure that no people or obstructions are below prior to lowering the crate.

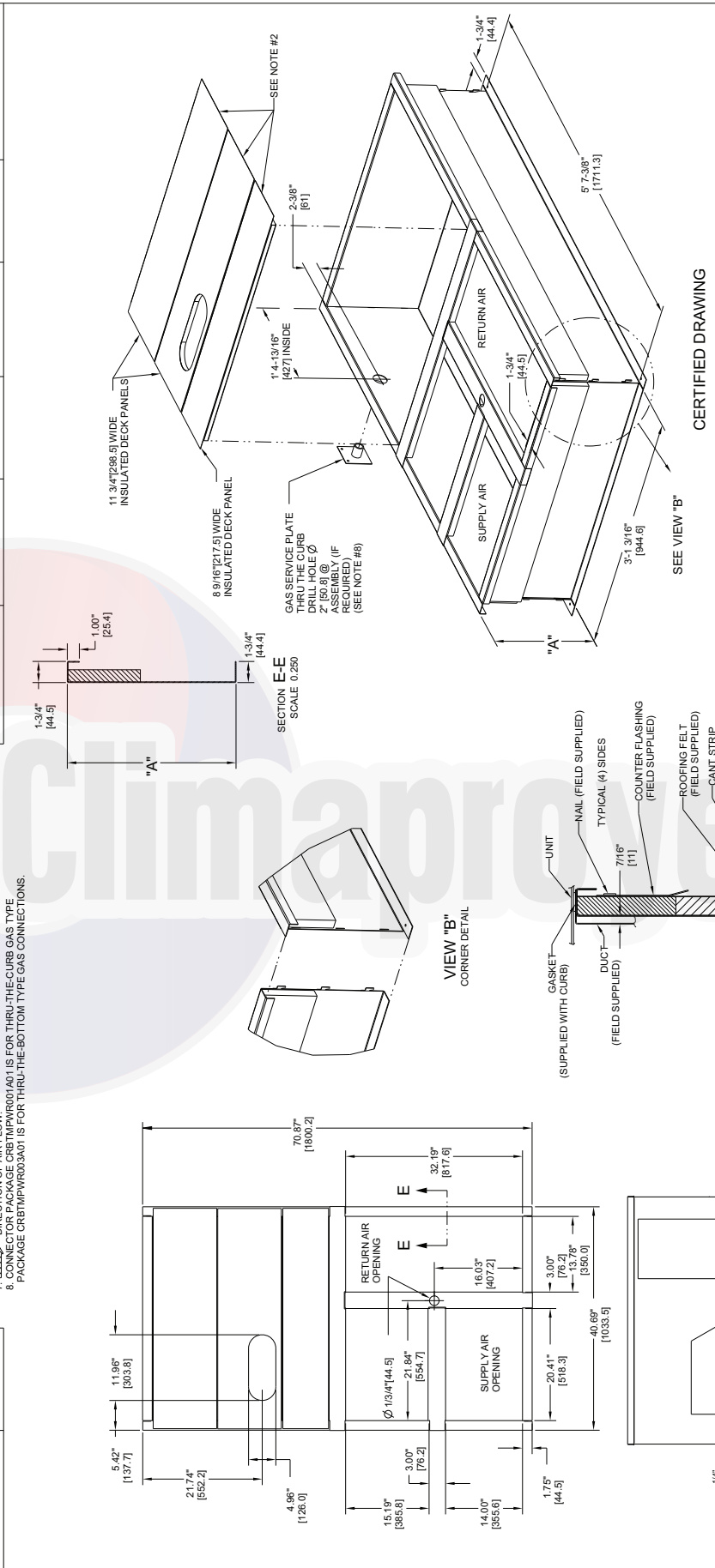
### POSITIONING ON CURB

Position unit on roof curb so that the following clearances are maintained: 1/4-in. (6.4 mm) clearance between the roof curb and the base rail inside the front and rear, 0.0-in. clearance between the roof curb and the base rail inside on the duct end of the unit. This will result in the distance between the roof curb and the base rail inside on the condenser end of the unit being approximately 1/4-in. (6.4 mm).

Although unit is weatherproof, guard against water from higher level runoff and overhangs.

After unit is in position, remove rigging skids and shipping materials.

CONNECTOR PKG. ACC.	GAS CONNECTION TYPE	GAS FITTING	POWER WIRING FITTING	CONTROL WIRING FITTING	ACCESSORY CONVENIENCE OUTLET WIRING CONNECTOR
CRBTMPWR001A01	THRU THE CURB	3/4" [19] NPT	3/4" [19] NPT	1/2" [12.7] NPT	1/2" [12.7] NPT
CRBTMPWR003A01	THRU THE BOTTOM	1/2" [12.7] NPT			



**CERTIFIED DRAWING**

**PRODUCTION**

UNLESS OTHERWISE SPECIFIED DIMENSIONS ARE IN INCHES TOLERANCES ON DIMENSIONS:

DRAWING RELEASE LEVEL:	THIRD ANGLE PROJECTION
MATERIAL:	-
ENGINEERING REQUIREMENTS:	1-005, Y-002
ENGINEERING:	MM
DRAWING NUMBER:	4817C400427
SIZE:	D
MANUFACTURING:	MM
CHECKER:	MM
DATE:	06/17/11
MODEL (INTERNAL USE ONLY):	
PURCH:	
SCALE:	N/A
DISTRIBUTION:	MMC
REV:	B

**REVISION RECORD**

REV	DATE	BY	CHKD	APPD	EQ. NO.
A	04/22/13	MMC	-	-	1067888

OVERALL DIM: 5'-7.38" WAS 5'-7.78"; 18GA MATERIAL WA 16 GA; NAIL FIELD SUPPLIED WAS WITH CURB

REVISION RECORD

Fig. 8 — Roof Curb Details

**⚠ CAUTION - NOTICE TO RIGGERS:  
⚠ AVERTISSEMENT - REMARQUE À  
L'ATTENTION DES MONTEURS**

**ALL PANELS MUST BE IN PLACE WHEN RIGGING.  
TOUS LES CAPOTS DOIVENT ÊTRE EN PLACE AVANT LE LEVAGE**

- Hook rigging shackles through holes in base rail, as shown in Detail "A".
- Use wooden top skid, when rigging, to prevent rigging straps from damaging unit.
- Max weight includes base unit plus shipping pallet plus all available FIOP's which could be on that size unit.
- "B" dimension is based on base unit (PAC no heat or YAC w/low heat) plus economizer option only. This dimension may vary slightly with units configured with other FIOP options.
- Spreader bars required to lift and transport the unit.
- Accrocher les manilles des élingues de levages dans les trous situés dans le rail de base comme indiqué au Détail « A ».
- Utiliser des cales en bois lors du levage pour éviter que les élingues n'endommagent le haut de l'appareil.
- Le poids maximum inclut la configuration de base, le poids de la palette d'expédition, ainsi que toutes les options pouvant être installées en usine (FIOP) pour la plateforme sélectionnée.
- La dimension de "B" provient de la configuration de base (PAC sans chauffage ou YAC chauffage au gaz naturel) qui inclut l'option economizer seulement. Cette dimension peut varier légèrement en fonction des différentes options sélectionnées, installées en usine (FIOP).
- Barres d'écartement requises pour soulever et transporter l'unité.



MODEL	MAX WEIGHT		A		B		C	
	LB	KG	IN	MM	IN	MM	IN	MM
50LC_004	700	318	74.5	1890	36.5	925	33.5	850
50LC_005	830	377	74.5	1890	36.5	925	41.5	1055
50LC_006	865	393	74.5	1890	36.0	915	41.5	1055
48LC_004	760	345	74.5	1890	38.0	965	33.5	850
48LC_005	895	407	74.5	1890	38.0	965	41.5	1055
48LC_006	930	423	74.5	1890	37.5	955	41.5	1055

48HC500030 A

**Fig. 9 — Rigging Label**

**Step 7 — Convert to Horizontal and Connect Ductwork (when required)**

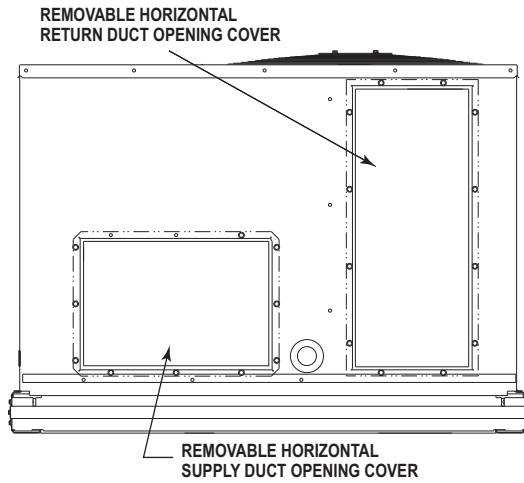
Unit is shipped in the vertical duct configuration. Unit without factory-installed economizer or return-air smoke detector option may be field-converted to horizontal ducted configuration. To convert to horizontal configuration, remove screws from side duct opening covers (see Fig. ?) and remove covers. Use the screws to install the covers on vertical duct openings with the insulation-side down. The panels must be inserted into the notches on the basepan to properly seal. The notches are covered by the tape used to secure the insulation to the basepan and are not easily seen. See

Fig. ? for position of the notches in the basepan. Seals around duct openings must be tight. Secure with screws as shown in Fig. ?. Cover seams with foil duct tape.

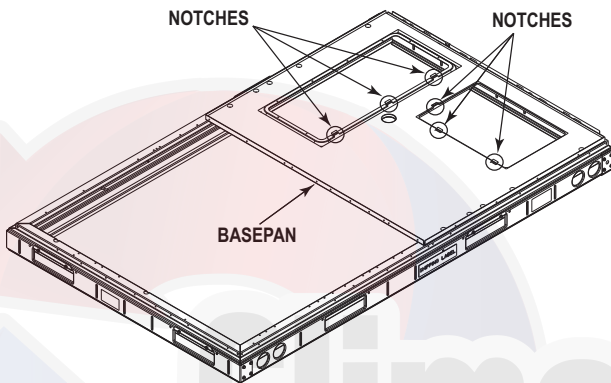
Field-supplied flanges should be attached to horizontal duct openings and all ductwork should be secured to the flanges. Insulate and weatherproof all external ductwork, joints, and roof or building openings with counter flashing and mastic in accordance with applicable codes.

Do not cover or obscure visibility to the unit's informative data plate when insulating horizontal ductwork.

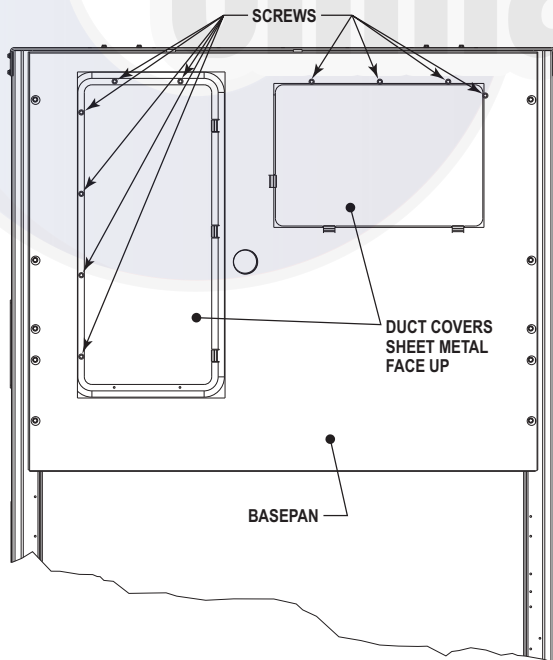




**Fig. 10 — Horizontal Conversion Panels**



**Fig. 11 — Location of Notches**

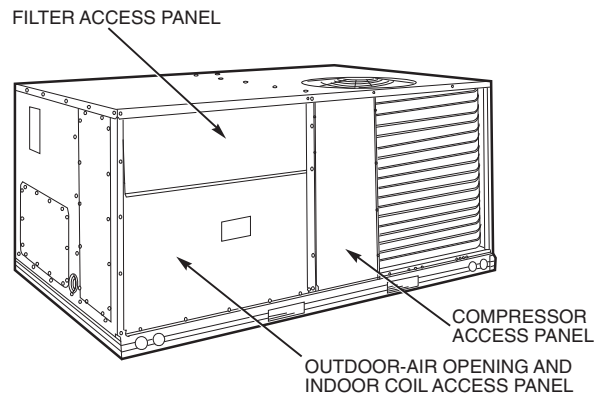


**Fig. 12 — Horizontal Duct Panels In Place**

## Step 8 — Install Outside Air Hood

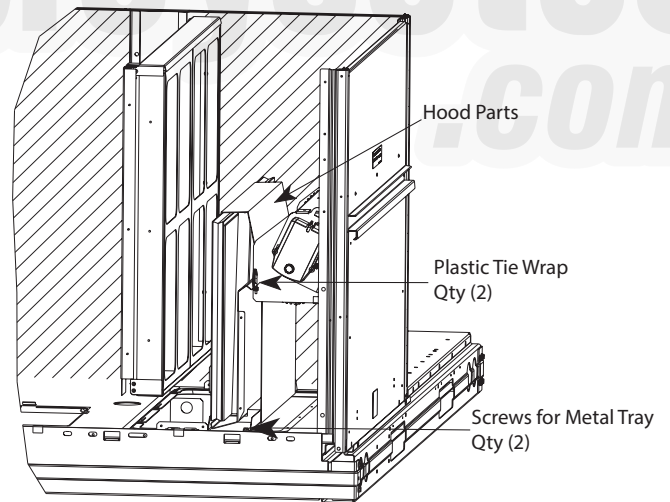
### ECONOMIZER HOOD PACKAGE REMOVAL AND SETUP - FACTORY OPTION

1. The hood is shipped in knock-down form and must be field-assembled. The indoor coil access panel is used as the hood top while the hood sides, divider and filter are packaged together, attached to a metal support tray using plastic stretch wrap, and shipped in the return-air compartment behind the indoor coil access panel. The hood assembly's metal tray is attached to the basepan and also attached to the damper using two plastic tie-wraps.
2. To gain access to the hood, remove the filter access panel. (See Fig. ?.)



**Fig. 13 — Typical Access Panel Locations**

3. Locate the 2 screws holding the metal tray to the basepan and remove. Locate and cut the 2 plastic tie-wraps securing the assembly to the damper. (See Fig. ?.) Be careful to not damage any wiring or cut tie-wraps securing any wiring.



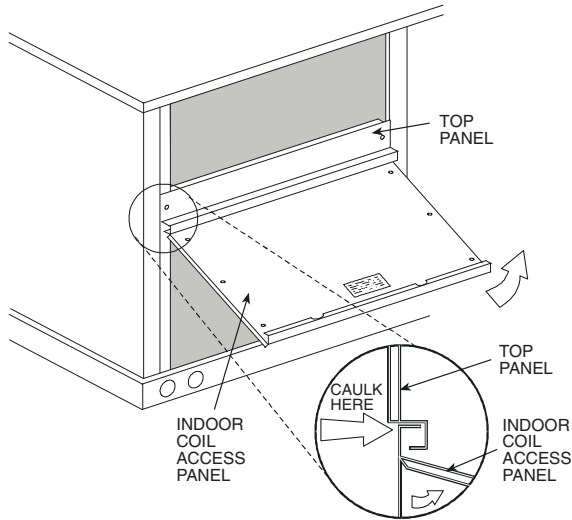
**Fig. 14 — Economizer Hood Parts Location**

4. Carefully lift the hood assembly (with metal tray) through the filter access opening and assemble per the steps outlined in Economizer Hood, below.

### ECONOMIZER HOOD

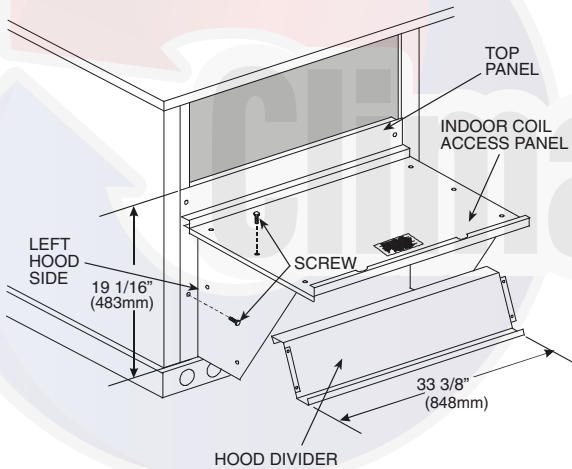
NOTE: If the power exhaust accessory is to be installed on the unit, the hood shipped with the unit will not be used and must be discarded. Save the aluminum filter for use in the power exhaust hood assembly.

1. The indoor coil access panel will be used as the top of the hood. Remove the screws along the sides and bottom of the indoor coil access panel. See Fig. ?.



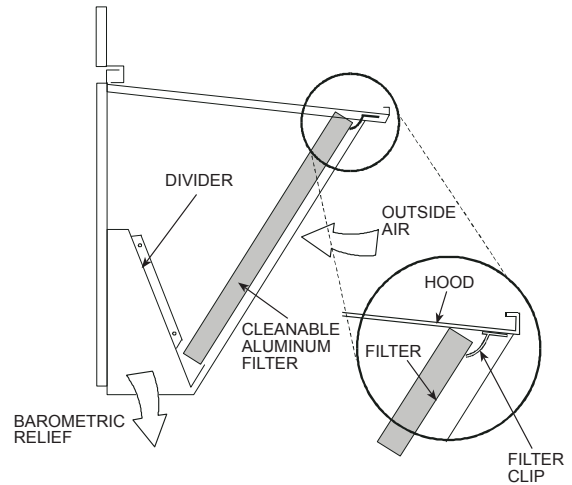
**Fig. 15 — Indoor Coil Access Panel Relocation**

2. Swing out indoor coil access panel and insert the hood sides under the panel (hood top). Use the screws provided to attach the hood sides to the hood top. Use screws provided to attach the hood sides to the unit. See Fig. ?.



**Fig. 16 — Economizer Hood Construction**

3. Remove the shipping tape holding the economizer barometric relief damper in place (economizer only).
4. Insert the hood divider between the hood sides. See Fig. ? and Fig. ?. Secure hood divider with 2 screws on each hood side. The hood divider is also used as the bottom filter rack for the aluminum filter.
5. Open the filter clips which are located underneath the hood top. Insert the aluminum filter into the bottom filter rack (hood divider). Push the filter into position past the open filter clips. Close the filter clips to lock the filter into place. See Fig. ?.
6. Caulk the ends of the joint between the unit top panel and the hood top.
7. Replace the filter access panel.

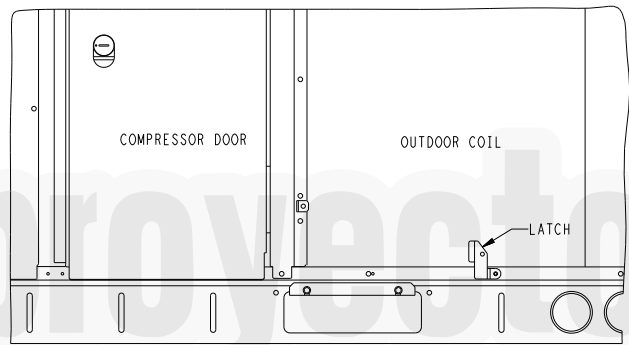


**Fig. 17 — Economizer Filter Installation**

**Step 9 — Units with Hinged Panels Only**

Relocate latch shipped inside the hinged compressor door to location shown in Fig. 18 after unit installation.

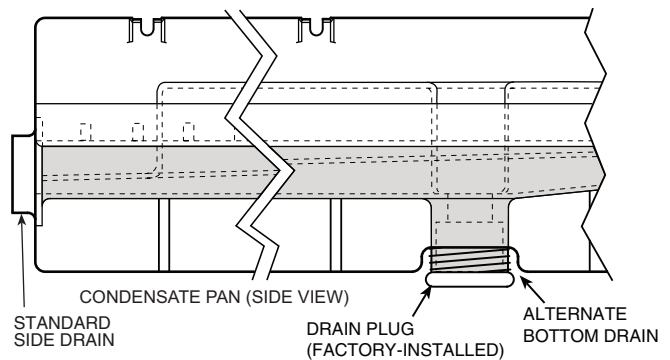
If the unit does not have hinged panels, skip Step 9 and continue at Step 10.



**Fig. 18 — Compressor Door Latch Location**

**Step 10 — Install External Condensate Trap and Line**

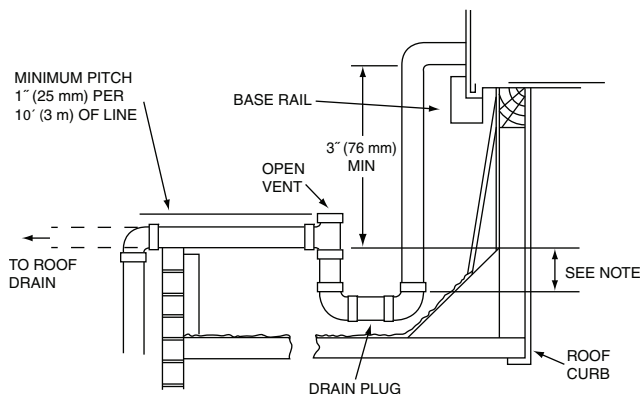
The unit has one <sup>3</sup>/<sub>4</sub>-in. condensate drain connection on the end of the condensate pan and an alternate connection on the bottom. See Fig. 19. Unit airflow configuration does not determine which drain connection to use. Either drain connection can be used with vertical or horizontal applications.



**Fig. 19 — Condensate Drain Pan (Side View)**

To use the alternate bottom drain connection, remove the red drain plug from the bottom connection (use a <sup>1</sup>/<sub>2</sub>-in. square socket drive extension) and install it in the side drain connection.

The piping for the condensate drain and external trap can be completed after the unit is in place. See Fig. 20.



NOTE: Trap should be deep enough to offset maximum unit static difference. A 4-in. (102 mm) trap is recommended.

**Fig. 20 — Condensate Drain Piping Details**

*All units must have an external trap for condensate drainage. Install a trap at least 4-in. (102 mm) deep and protect against freeze-up. If drain line is installed downstream from the external trap, pitch the line away from the unit at 1-in. per 10 ft (25 mm in 3 m) of run. Do not use a pipe size smaller than the unit connection (3/4-in.).*

### Step 11 — Make Electrical Connections

#### ⚠ WARNING

##### ELECTRIC SHOCK HAZARD

Failure to follow this warning could result in personal injury or death.

Unit cabinet must have an uninterrupted, unbroken electrical ground to minimize the possibility of personal injury if an electrical fault should occur. This ground may consist of electrical wire connected to unit ground lug in control compartment, or conduit approved for electrical ground when installed in accordance with NEC; ANSI/NFPA 70, latest edition (in Canada, Canadian Electrical Code CSA [Canadian Standards Association] C22.1), and local electrical codes.

NOTE: Field-supplied wiring shall conform with the limitations of minimum 63°F (33°C) rise.

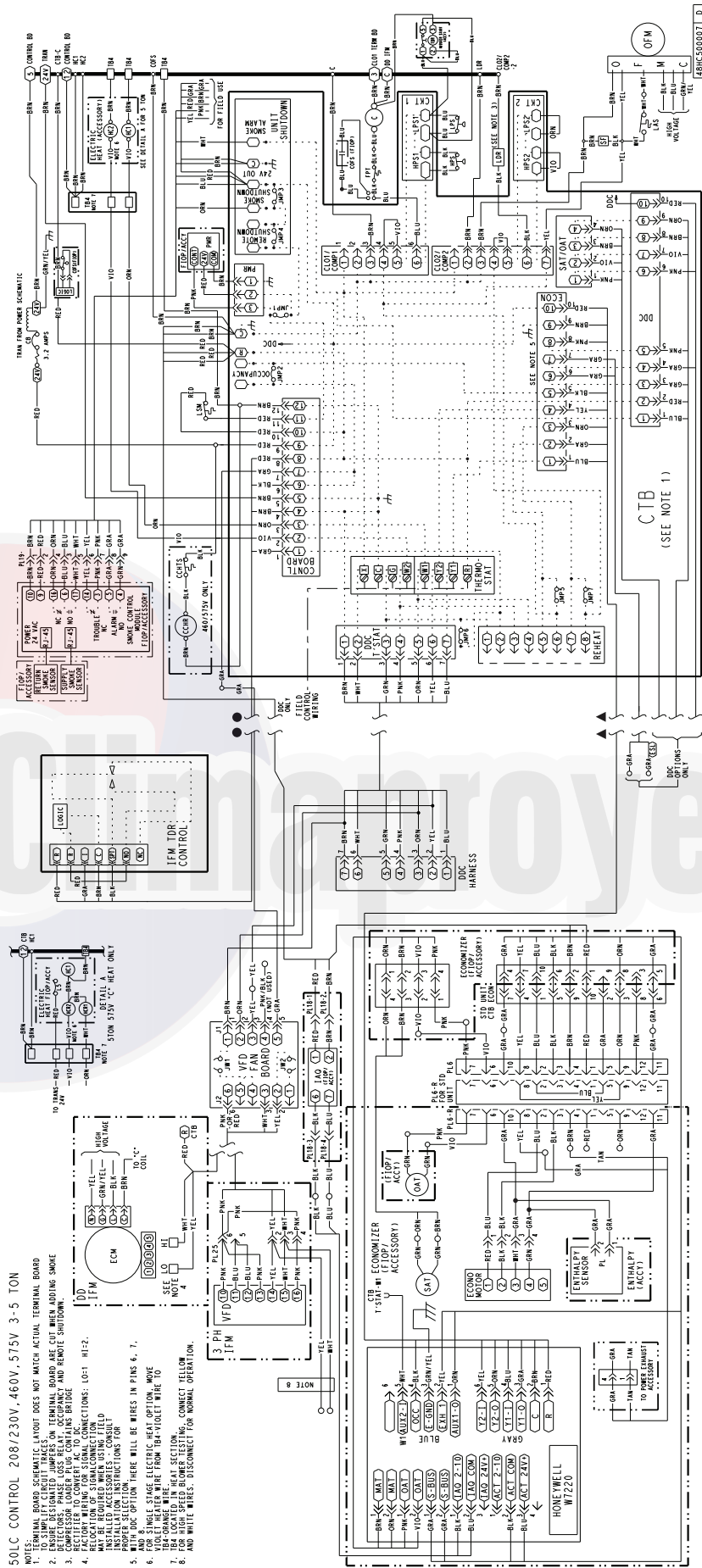
#### FIELD POWER SUPPLY

If equipped with optional Powered Convenience Outlet: The power source leads to the convenience outlet's transformer primary are not factory-connected. Installer must connect these leads according to required operation of the convenience outlet. If an always-energized convenience outlet operation is desired, connect the source leads to the line side of the unit-mounted disconnect. (Check with local codes to ensure this method is acceptable in your area.) If a de-energize via unit disconnect switch operation of the convenience outlet is desired, connect the source leads to the load side of the unit disconnect. On a unit without a unit-mounted disconnect, connect the source leads to compressor contactor C and indoor fan terminal block (IFTB) pressure lugs with unit field power leads.

Refer to Fig. 34 for power transformer connections and the discussion on connecting the convenience outlet on page 24.

Field power wires are connected to the unit at line-side pressure lugs on compressor contactor C and indoor fan terminal block (IFTB) (see wiring diagram label for control box component arrangement) or at factory-installed option non-fused disconnect switch or HACR. Max wire size is #2ga AWG (copper only) per pole on contactors. #2ga AWG per pole on optional disconnect or HACR and 4/0 AWG per pole on terminal or fuse block on units with single point box. See Fig. 26 and unit label diagram for field power wiring connections. See Fig. 21-25 for typical wiring diagrams.





- 50LC CONTROL 208/230V, 460V, 575V 3-5 TON
- NOTE: TERMINAL BOARD SCHEMATIC LAYOUT DOES NOT MATCH ACTUAL TERMINAL BOARD TO SIMPLIFY CIRCUIT TRACES ON TERMINAL BOARD ARE ONE WHEN BIDDING SMOKE DETECTORS, PHASE LOSS RELAY, OCCUPANCY AND REMOTE SHUTDOWN SWITCHES TO CONVERT TO 240V ALARM BRIDGE
- FACTORY WIRING FOR SIGNAL CONNECTIONS: LOT1 #1-2.
  - MAY BE REQUIRED WHEN USING FIELD INSTALLED OCCUPANCY SWITCHES FOR PROPER SELECTION.
  - AND B. OPTION THERE WILL BE WIRES IN PINS 6, 7.
  - VIO. #1 WIRE FOR WIRE FROM TRANSFORMER TO
  - 184-ORANGE WIRE. HEAT SECTION.
  - FOR HIGH SPEED BLOWER TESTING, CONNECT YELLOW AND WHITE WIRES. DISCONNECT FOR NORMAL OPERATION.

Fig. 21 — 50LC Control Wiring Diagram

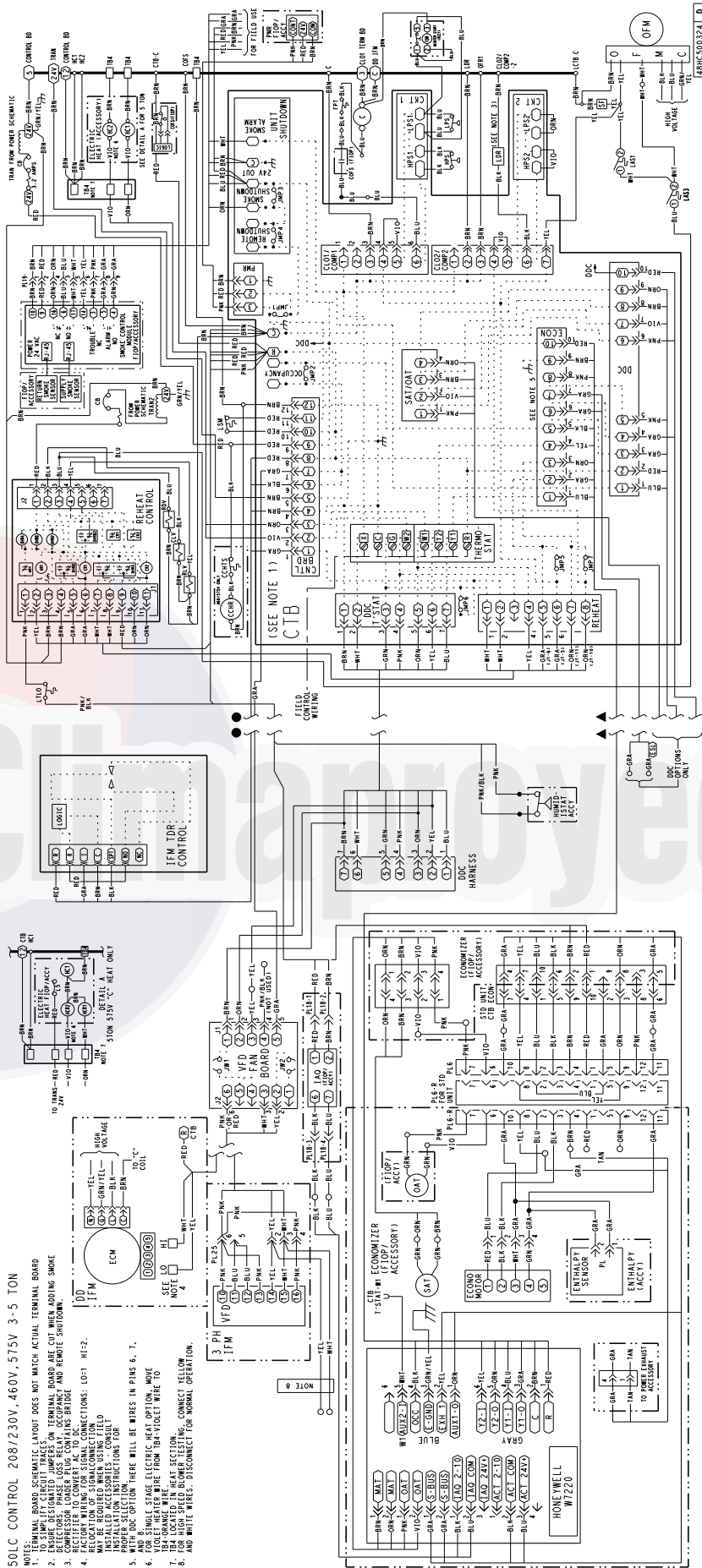
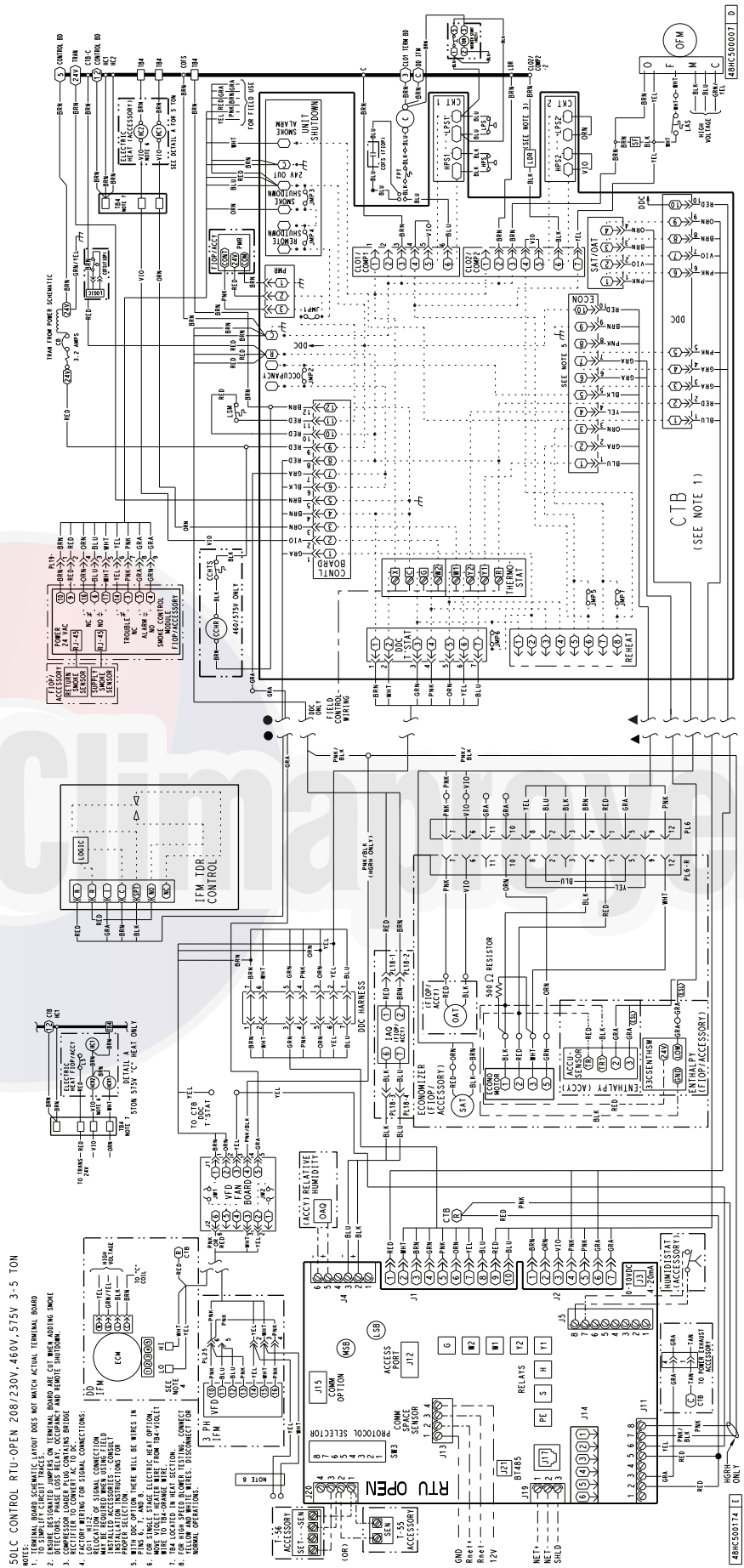


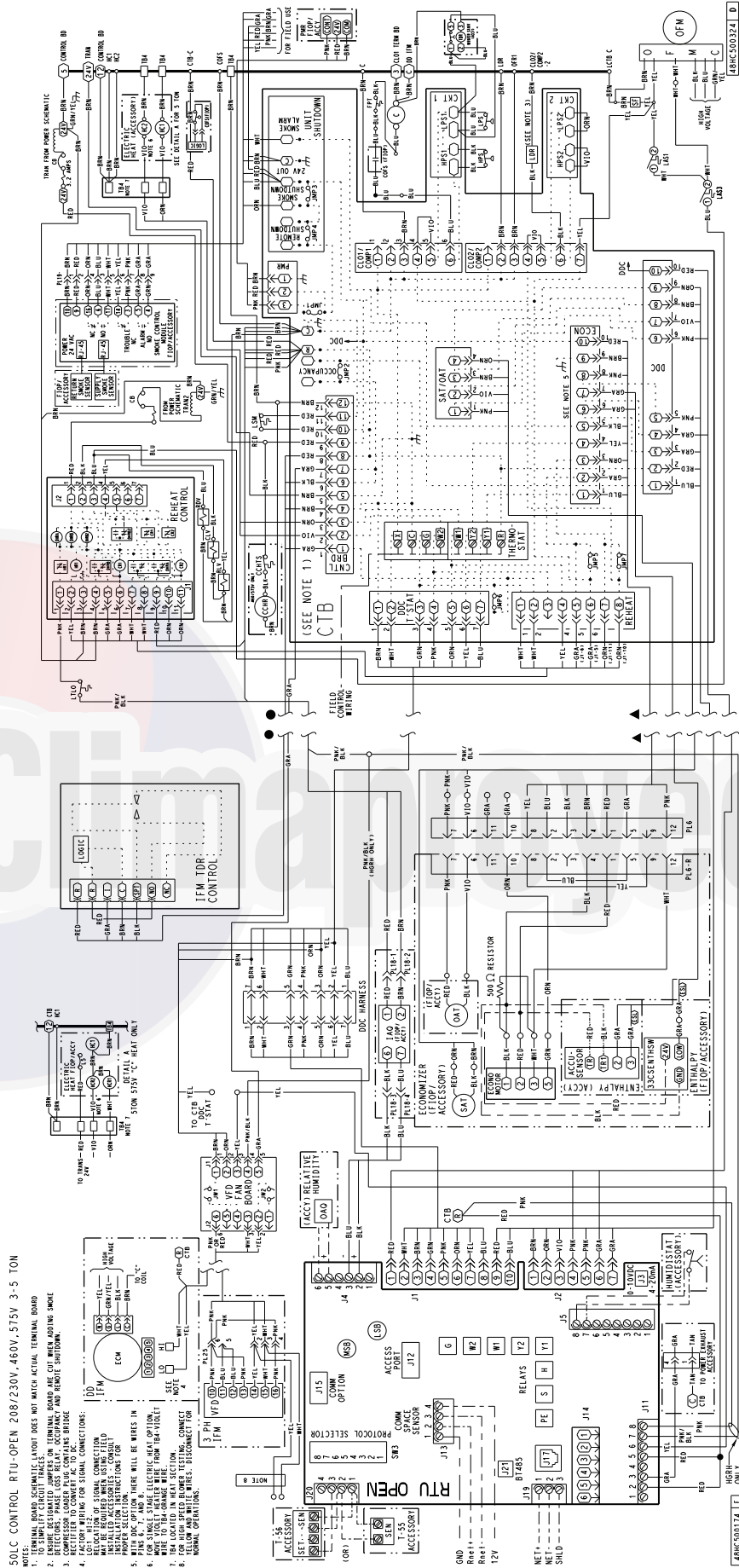
Fig. 22 — 50LC Control Wiring Diagram with Humidi-MiZer® System



50LC CONTROL RTU-OPEN 208/230V, 460V, 575V 3-5 TON

1. WIRE LEFT CIRCUIT TRACES.
2. DETECTORS: PHASE LOSS RELAY, OCCUPANCY AND REMOTE SWITCHING.
3. SENSITIVITY TO COMPRESSOR TO MAIN BRIDGE.
4. FACTORY WIRING FOR SIGNAL CONNECTIONS.
5. FOR SINGLE PHASE ELECTRIC HEAT OPTION: INSTALL ACCESSORIES, CONSULT INSTALLATION INSTRUCTIONS FOR PROPER SELECTION.
6. PIN 1, 2, 3 AND 4 THERE WILL BE WIRES IN.
7. WIRE TO RED-GRADE WIRE.
8. FOR HIGH SPEED BLOWER TESTING, CONNECT WIRE TO HIGH SPEED BLOWER TESTING, CONNECT WIRE TO BLOWER TESTING, DISCONNECTOR.

Fig. 23 — RTU Open System Control Wiring Diagram



- 50LC CONTROL RTU-OPEN 208/230V, 460V, 575V 3-5 TON
- NOTES:  
 1. TERMINAL BOARD SCHEMATIC LAYOUT DOES NOT MATCH ACTUAL TERMINAL BOARD  
 2. TO SIMPLIFY CIRCUIT TRACES  
 3. DETECTORS PHASE LOSS RELAY, OCCUPANCY AND REMOTE SWITCHING  
 4. IDENTIFIER TO CONVERT TO MAIN BRIDGE  
 5. FACTORY WIRING FOR SIGNAL CONNECTIONS  
 6. RELOCATION OF SIGNAL CONNECTIONS  
 7. UNLabeled ACCESSORIES - CONSULT  
 8. PROPER SELECTION CONNECTIONS FOR  
 9. FACTORY WIRING FOR SIGNAL CONNECTIONS  
 10. FOR SINGLE STAGE ELECTRIC HEAT OPTION  
 11. WIRE TO 12V BATTERY  
 12. FOR HIGH SPEED BLOWER TESTING, CONNECT  
 13. NORMAL OPERATING

Fig. 24 — RTU Open System Control Wiring Diagram with Humidi-MiZer® System

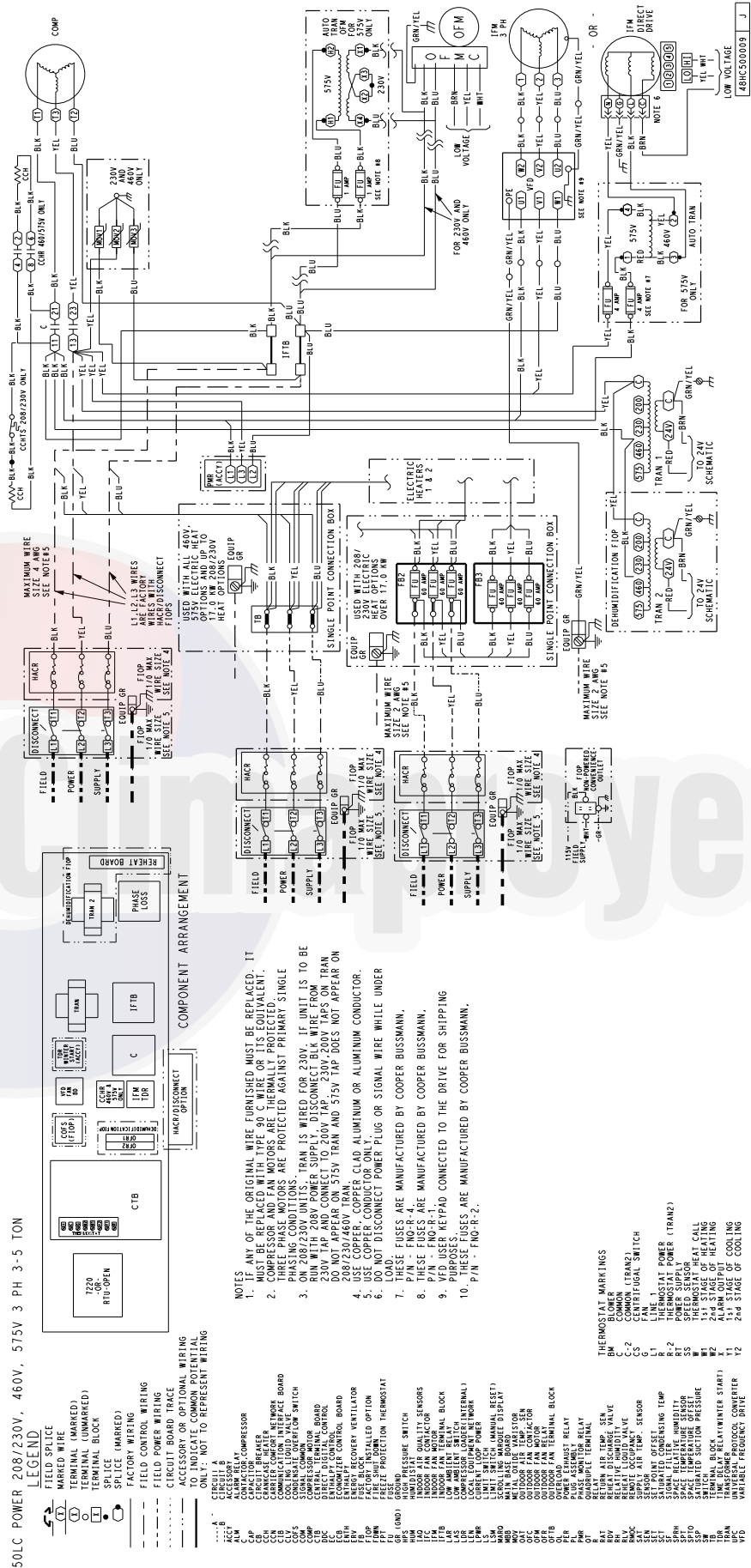


Fig. 25 — 50LC Power Wiring Diagram, 208/230-v, 460-v, 575-v 3 Phase



Units Without Single Point Box, Disconnect or HACR Option

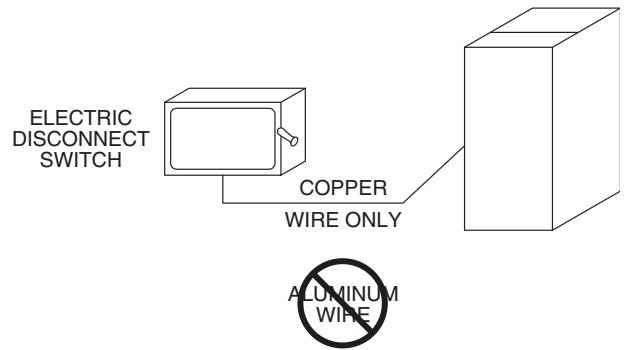
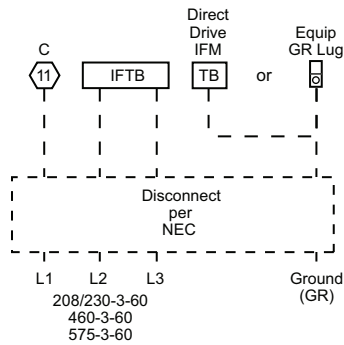


Fig. 27 — Disconnect Switch and Unit

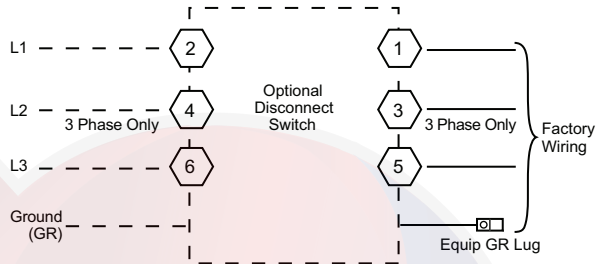
UNITS WITH FACTORY-INSTALLED NON-FUSED DISCONNECT OR HACR

The factory-installed optional non-fused disconnect (NFD) or HACR switch is located in a weatherproof enclosure located under the main control box. The manual switch handle and shaft is shipped in the disconnect or HACR enclosure. Assemble the shaft and handle to the switch at this point.

TO FIELD-INSTALL THE NFD SHAFT AND HANDLE:

1. Remove the Control Box access panel. The NFD enclosure is located below the Control Box (see Fig 28).
2. Remove (3) cap head screws that secure the NFD enclosure front cover – (2) on the face of the cover and (1) on the left side cover. See Fig 29.
3. Remove the front cover of the NFD enclosure.
4. Make sure the NFD shipped from the factory is at OFF position (the arrow on the black handle knob is at OFF).
5. Insert the shaft with the cross pin on the top of the shaft in the horizontal position.
6. Measure from the tip of the shaft to the top surface of the black pointer; the measurement should be 3.75-in. to 3.88-in. (95 mm to 99 mm).
7. Tighten the locking screw to secure the shaft to the NFD.
8. Turn the handle to the OFF position with red arrow pointing at OFF.
9. Install the handle on to the painted cover horizontally with the red arrow pointing to the left.
10. Secure the handle to the painted cover with (2) screws and lock washers supplied.
11. Engaging the shaft into the handle socket, re-install (3) cap head screws on the front cover.
12. Re-install the unit front panel.

Units With Disconnect or HACR Option



Units With Electric Heat Option with Single Point Box and Without Disconnect or HACR Option

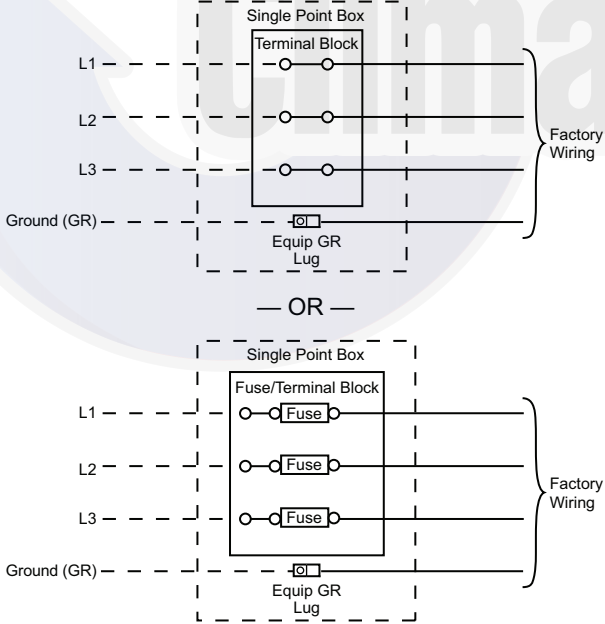


Fig. 26 — Power Wiring Connections

**⚠ WARNING**

**FIRE HAZARD**  
 Failure to follow this warning could result in personal injury, death, or property damage.  
 Do not connect aluminum wire between disconnect switch and unit. Use only copper wire.

See Fig. 27.

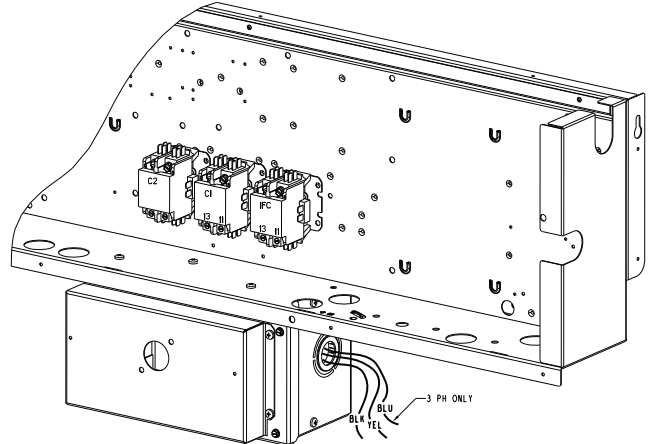
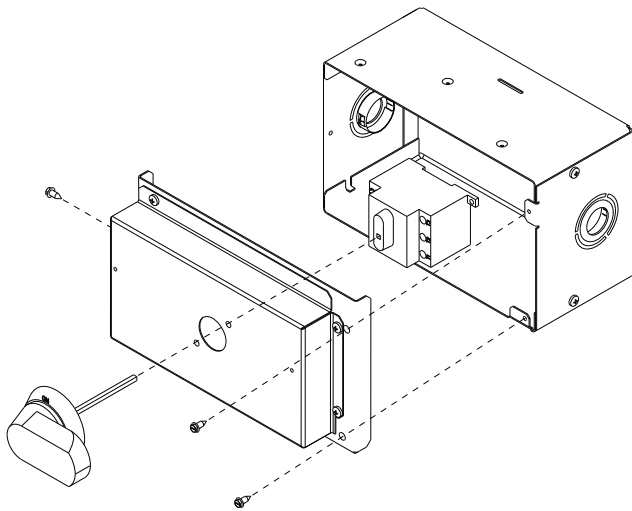
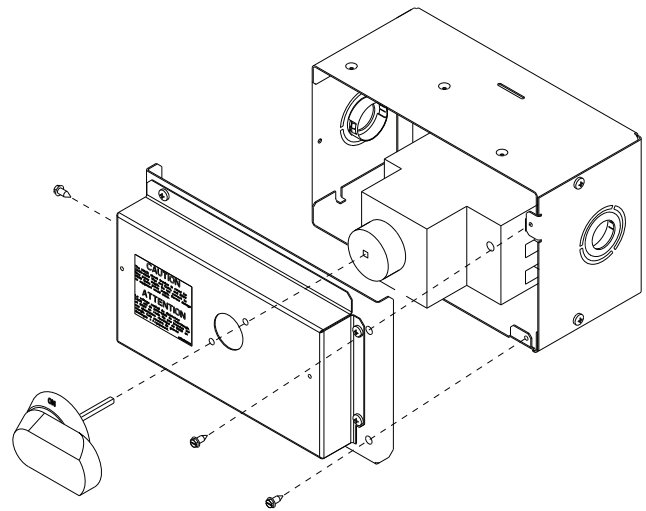


Fig. 28 — Location of Non-Fused Disconnect Enclosure



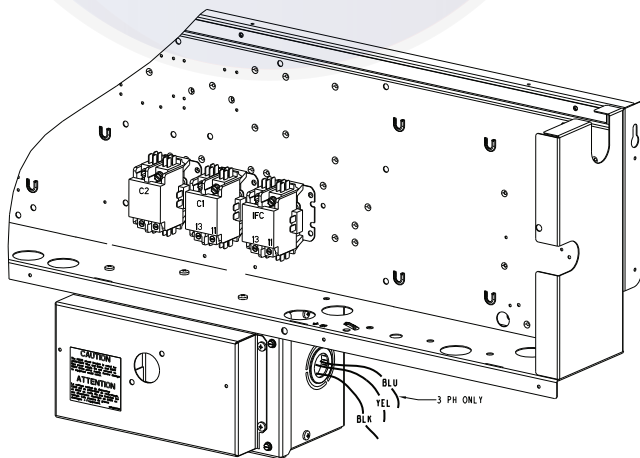
**Fig. 29 — Handle and Shaft Assembly for NFD**



**Fig. 31 — Handle and Shaft Assembly for HACR**

**TO FIELD-INSTALL THE HACR SHAFT AND HANDLE:**

1. Remove the Control Box access panel. The HACR enclosure is located below the Control Box (see Fig. 30).
2. Remove (3) cap head screws that secure the HACR enclosure – (2) on the face of the cover and (1) on the left side cover. See Fig. 31.
3. Remove the front cover of the HACR enclosure.
4. Make sure the HACR shipped from the factory is at OFF position (the white arrow pointing at OFF).
5. Insert the shaft all the way with the cross pin on the top of the shaft in the horizontal position.
6. Tighten the locking screw to secure the shaft to the HACR.
7. Turn the handle to the OFF position with red arrow pointing at OFF.
8. Install the handle on to the painted cover horizontally with the red arrow pointing to the left.
9. Secure the handle to the painted cover with (2) screws and lock washers supplied.
10. Engaging the shaft into the handle socket, re-install (3) cap head screws on the front cover.
11. Re-install the unit front panel.



**Fig. 30 — Location of HACR Enclosure**

**UNITS WITHOUT FACTORY-INSTALLED DISCONNECT OR HACR**

When installing units, provide a disconnect switch per NEC (National Electrical Code) of adequate size. Disconnect sizing data is provided on the unit informative plate. Locate on unit cabinet or within sight of the unit per national or local codes. Do not cover unit informative plate if mounting the disconnect on the unit cabinet.

**ALL UNITS**

All field wiring must comply with NEC and all local codes. Size wire based on MCA (Minimum Circuit Amps) on the unit informative plate. See Fig. 26 and the unit label diagram for power wiring connections to the unit power terminal blocks and equipment ground. Maximum wire size is #2ga AWG per pole on contactors. #2ga AWG per pole on optional disconnect or HACR and 4/0 AWG per pole on terminal or fuse block on units with single point box. See Fig. 26 and unit label diagram for field power wiring connections.

Provide a ground-fault and short-circuit over-current protection device (fuse or breaker) per NEC Article 440 (or local codes). Refer to unit informative data plate for MOCP (Maximum Over-current Protection) device size.

**NOTE:** Units ordered with factory installed HACR do not need an additional ground-fault and short-circuit over-current protective device unless required by local codes.

All field wiring must comply with the NEC and local requirements.

All units except 208/230-v units are factory wired for the voltage shown on the nameplate. If the 208/230-v unit is to be connected to a 208-v power supply, the control transformer must be rewired by moving the black wire with the 1/4-in. female spade connector from the 230-v connection and moving it to the 200-v 1/4-in. male terminal on the primary side of the transformer. Refer to unit label diagram for additional information.

**NOTE:** Check all factory and field electrical connections for tightness.



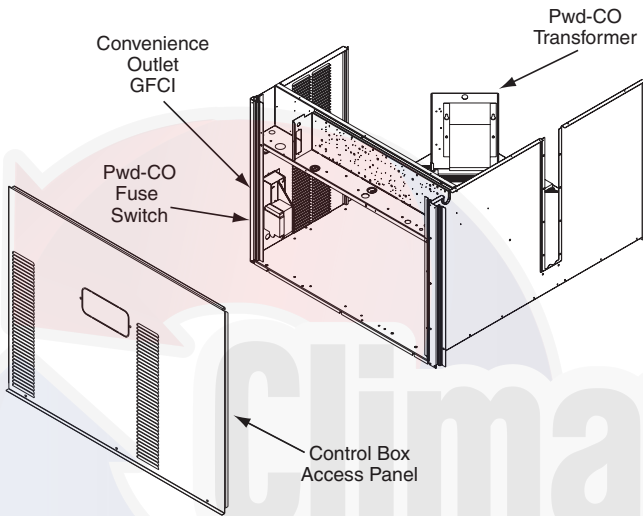
**⚠ WARNING**

**ELECTRICAL OPERATION HAZARD**

Failure to follow this warning could result in personal injury or death.

Units with convenience outlet circuits may use multiple disconnects. Check convenience outlet for power status before opening unit for service. Locate its disconnect switch, if appropriate, and open it. Lock-out and tag-out this switch, if necessary.

Two types of convenience outlets are offered: non-powered and unit-powered. Both types provide a 125-v GFCI (ground-fault circuit-interrupter) duplex receptacle rated at 15-A behind a hinged waterproof access cover, located on the end panel of the unit. See Fig. 32.



**Fig. 32 — Convenience Outlet Location**

**Installing Weatherproof Cover**

A weatherproof while-in-use cover for the factory-installed convenience outlets is now required by UL standards. This cover cannot be factory-mounted due to its depth; it must be installed at unit installation. For shipment, the convenience outlet is covered with a blank cover plate.

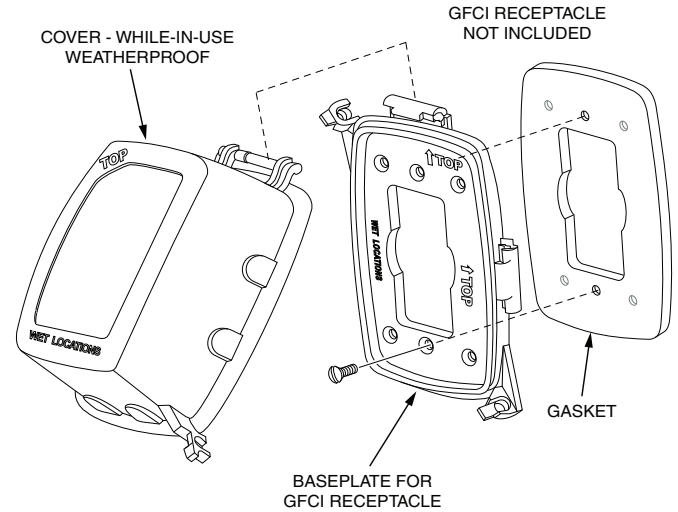
The weatherproof cover kit is shipped in the unit’s control box. The kit includes the hinged cover, a backing plate and gasket.

**DISCONNECT ALL POWER TO UNIT AND CONVENIENCE OUTLET. LOCK-OUT AND TAG-OUT ALL POWER.**

Remove the blank cover plate at the convenience outlet; discard the blank cover.

Loosen the two screws at the GFCI duplex outlet, until approximately 1/2-in. (13 mm) under screw heads is exposed. Press the gasket over the screw heads. Slip the backing plate over the screw heads at the keyhole slots and align with the gasket; tighten the two screws until snug (do not over-tighten).

Mount the weatherproof cover to the backing plate as shown in Fig. 33. Remove two slot fillers in the bottom of the cover to permit service tool cords to exit the cover. Check for full closing and latching.



**Fig. 33 — Weatherproof Cover Installation**

**Non-powered type**

This type requires the field installation of a general-purpose 125-v 15-A circuit powered from a source elsewhere in the building. Observe national and local codes when selecting wire size, fuse or breaker requirements and disconnect switch size and location. Route 125-v power supply conductors into the bottom of the utility box containing the duplex receptacle.

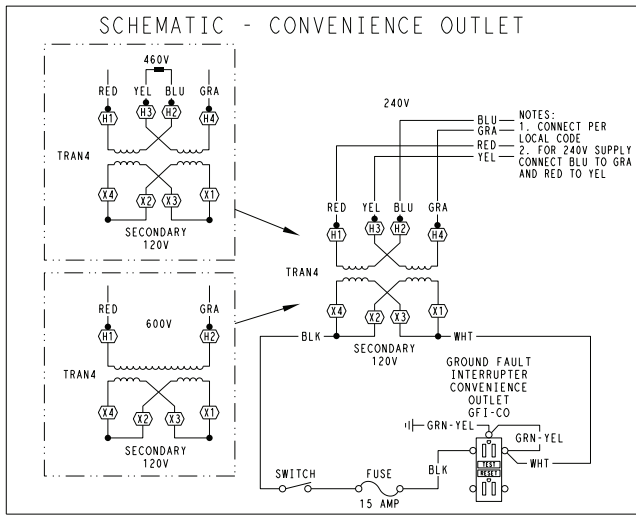
**Unit-powered type**

A unit-mounted transformer is factory-installed to stepdown the main power supply voltage to the unit to 115-v at the duplex receptacle. This option also includes a manual switch with fuse, located in a utility box and mounted on a bracket behind the convenience outlet; access is through the unit’s control box access panel. See Fig. 32.

The primary leads to the convenience outlet transformer are not factory-connected. Selection of primary power source is a customer option. If local codes permit, the transformer primary leads can be connected at the line-side terminals on the unit-mounted non-fused disconnect or HACR breaker switch; this will provide service power to the unit when the unit disconnect switch or HACR switch is open. Other connection methods will result in the convenience outlet circuit being de-energized when the unit disconnect or HACR switch is open. See Fig. 34.

**Using unit-mounted convenience outlets**

Units with unit-mounted convenience outlet circuits will often require that two disconnects be opened to de-energize all power to the unit. Treat all units as electrically energized until the convenience outlet power is also checked and de-energization is confirmed. Observe National Electrical Code Article 210, Branch Circuits, for use of convenience outlets.



UNIT VOLTAGE	CONNECT AS	PRIMARY CONNECTIONS	TRANSFORMER TERMINALS
208, 230	240	L1: RED + YEL L2: BLU + GRA	H1 + H3 H2 + H4
460	480	L1: RED Splice BLU + YEL L2: GRA	H1 H2 + H3 H4
575	600	L1: RED L2: GRA	H1 H2

Fig. 34 — Powered Convenience Outlet Wiring

**Fuse on power type:**

The factory fuse is a Bussman<sup>1</sup> “Fusetron” T-15, non-renewable screw-in (Edison base) type plug fuse.

**Duty Cycle**

The unit-powered convenience outlet has a duty cycle limitation. The transformer is intended to provide power on an intermittent basis for service tools, lamps, etc; it is not intended to provide 15 amps loading for continuous duty loads (such as electric heaters for overnight use). Observe a 50% limit on circuit loading above 8 amps.

**Convenience outlet usage rating:**

Continuous usage: 8 amps maximum. See Fig. 35.

Test the GFCI receptacle by pressing the TEST button on the face of the receptacle to trip and open the receptacle. Check for proper grounding wires and power line phasing if the GFCI receptacle does not trip as required. Press the RESET button to clear the tripped condition.

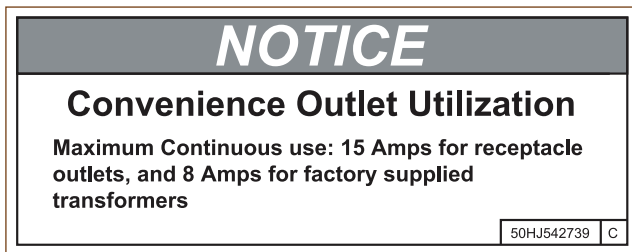


Fig. 35 — Convenience Outlet Utilization Notice Label

1. Bussman and Fusetron are trademarks of Cooper Technologies Company.

**HACR**

The amp rating of the HACR factory-installed option is based on the size, voltage, indoor motor and other electrical options of the unit as shipped from the factory. If field-installed accessories are added or changed in the field (i.e. electric heat, power exhaust, ERV), the HACR may no longer be of the proper amp rating and therefore will need to be removed from the unit. See unit nameplate and label on factory-installed HACR for the amp rating of the HACR that was shipped with the unit from the factory. See unit nameplates for the proper fuse, HACR or maximum over-current protection device required on the unit with field installed accessories. See Fig. 36 for HACR caution label.

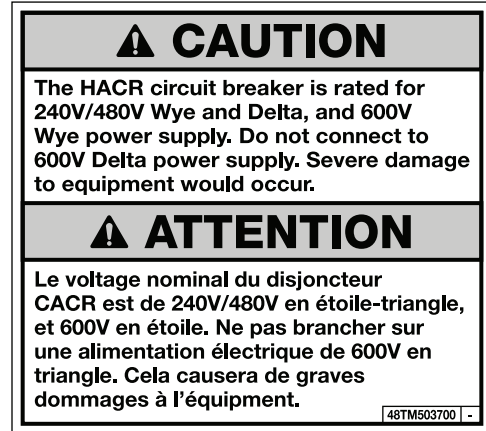


Fig. 36 — HACR Caution Label

**FACTORY-OPTION THRU-BASE CONNECTIONS**

This service connection kit consists of two 1/2-in. electrical bulkhead connectors and a 3/4-in. electrical bulkhead connector, all factory-installed in the embossed (raised) section of the unit basepan in the condenser section. The 3/4-in. bulkhead connector enables the low-voltage control wires to pass through the basepan. The 1/2-in. electrical bulkhead connector allows the high-voltage power wires to pass through the basepan. See Fig. 37 or 38.

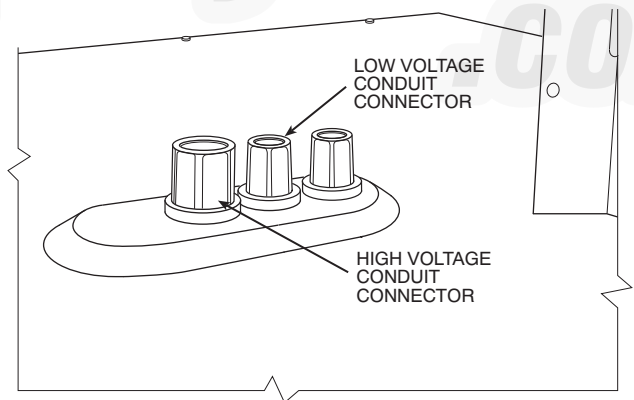
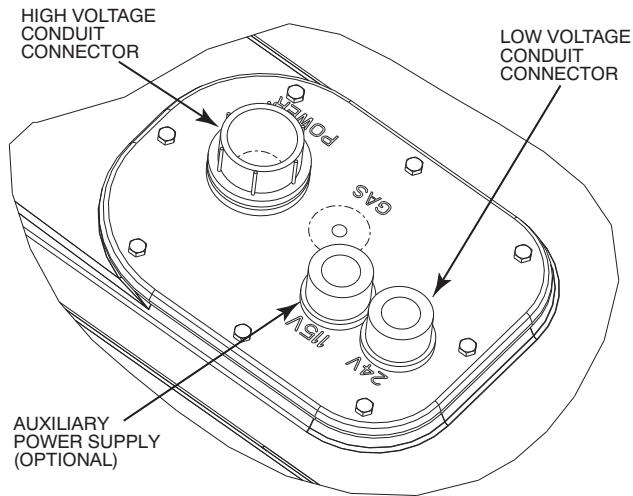


Fig. 37 — Thru-Base Connection Fittings for Units Built Prior to 4/15/19



**Fig. 38 — Thru-Base Connection Fittings for Units Built On and After 4/15/19**

Check tightness of connector lock nuts before connecting electrical conduits.

Field-supplied and field-installed liquid tight conduit connectors and conduit may be attached to the connectors on the basepan. Pull correctly rated high-voltage and low-voltage through appropriate conduits. Connect the power conduit to the internal disconnect (if unit is so equipped) or to the external disconnect (through unit side panel). A hole must be field cut in the main control box bottom on the left side so the 24-v control connections can be made. Connect the control power conduit to the unit control box at this hole.

#### UNITS WITHOUT THRU-BASE CONNECTIONS

1. Install power wiring conduit through side panel openings. Install conduit between disconnect and control box.
2. Install power lines to terminal connections as shown in Fig. 26.

Voltage to compressor terminals during operation must be within voltage range indicated on unit nameplate. On 3-phase units, voltages between phases must be balanced within 2% and the current within 10%. Use the formula shown below to determine the percent of voltage imbalance. Operation on improper line voltage or excessive phase imbalance constitutes abuse and may cause damage to electrical components. Such operation would invalidate any applicable Carrier warranty.

Never operate a motor where a phase imbalance in supply voltage is greater than 2%. Use the following formula to determine the percentage of voltage imbalance.

% Voltage Imbalance:

$$= 100 \times \frac{\text{max voltage deviation from average voltage}}{\text{average voltage}}$$

Example: Supply voltage is 230-3-60



AB = 224 v  
BC = 231 v  
AC = 226 v

$$\text{Average Voltage} = \frac{(224 + 231 + 226)}{3} = \frac{681}{3} = 227$$

Determine maximum deviation from average voltage.

(AB) 227-224 = 3 v

(BC) 231-227 = 4 v

(AC) 227-226 = 1 v

Maximum deviation is 4 v.

Determine percent of voltage imbalance.

$$\% \text{ Voltage Imbalance} = 100 \times \frac{4}{227} = 1.78\%$$

This amount of phase imbalance is satisfactory as it is below the maximum allowable 2%.

**IMPORTANT:** If the supply voltage phase imbalance is more than 2%, contact your local electric utility company immediately.

NOTE: Check all factory and field electrical connections for tightness.

#### FIELD CONTROL WIRING

The 50LC unit requires an external temperature control device. This device can be a thermostat (field-supplied) or, the RTU Open Controller for Building Management Systems using non-CCN protocols (RTU Open is available as a factory-installed option only), or a space temperature sensor (SPT) with factory installed SystemVu™ controller.

#### THERMOSTAT

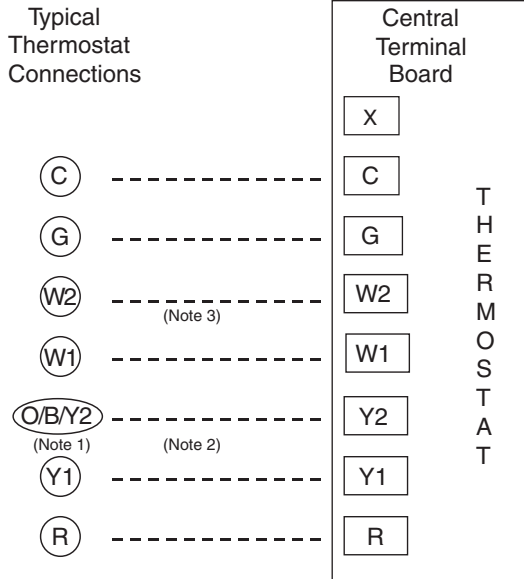
Select a Carrier-approved accessory thermostat. When electric heat is installed in the 50LC unit, the thermostat must be capable of energizing the G terminal (to energize the Indoor Fan Contactor) whenever there is a space call for heat (energizing the W1 terminal). See Fig. 39. The accessory thermostats listed on the unit price pages can provide this signal but they are not configured to enable this signal as shipped.

Install the accessory thermostat according to installation instructions included with the accessory.

Locate the thermostat accessory on a solid wall in the conditioned space to sense average temperature in accordance with the thermostat installation instructions.

If the thermostat contains a logic circuit requiring 24-v power, use a thermostat cable or equivalent single leads of different colors with minimum of seven leads. If the thermostat does not require a 24-v source (no "C" connection required), use a thermostat cable or equivalent with minimum of six leads. Check the thermostat installation instructions for additional features which might require additional conductors in the cable.

For wire runs up to 50 ft (15 m), use no. 18 AWG (American Wire Gage) insulated wire [35°C (95°F) minimum]. For 50 to 75 ft (15 to 23 m), use no. 16 AWG insulated wire [35°C (95°F) minimum]. For over 75 ft (23 m), use no. 14 AWG insulated wire [35°C (95°F) minimum]. All wire sizes larger than no. 18 AWG cannot be directly connected to the thermostat and will require a junction box and splice at the thermostat.



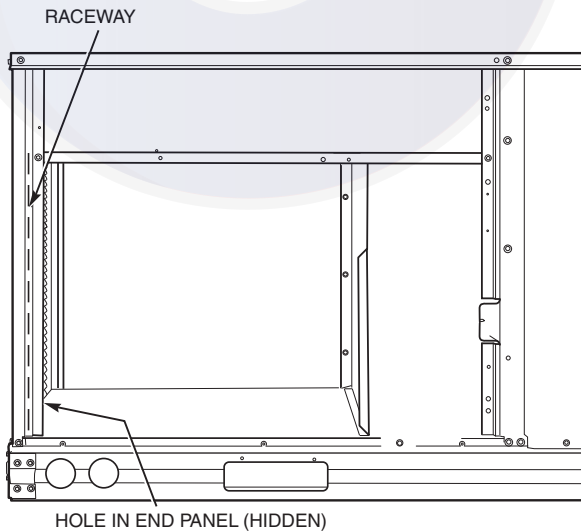
- Note 1: Typical multi-function marking. Follow manufacturer's configuration instructions to select Y2.
- Note 2: Y2 to Y2 connection required for 2 stage cooling operation and when integrated economizer function is desired
- Note 3: W2 connection not required on units with single-stage heating.
- Field Wiring

**Fig. 39 — Low-Voltage Connections**

**UNIT WITHOUT THRU-BASE CONNECTION KIT**

Pass the thermostat control wires through the hole provided in the corner post; then feed the wires through the raceway built into the corner post to the control box. Pull the wires over to the terminal strip on the upper-left corner of the Controls Connection Board. See Fig. 40.

NOTE: If thru-the-bottom connections accessory is used, refer to the accessory installation instructions for information on routing power and control wiring.



**Fig. 40 — Field Control Wiring Raceway**

**HEAT ANTICIPATOR SETTINGS**

Set heat anticipator settings at 0.14 amp for the first stage and 0.14 amp for second-stage heating, when available.

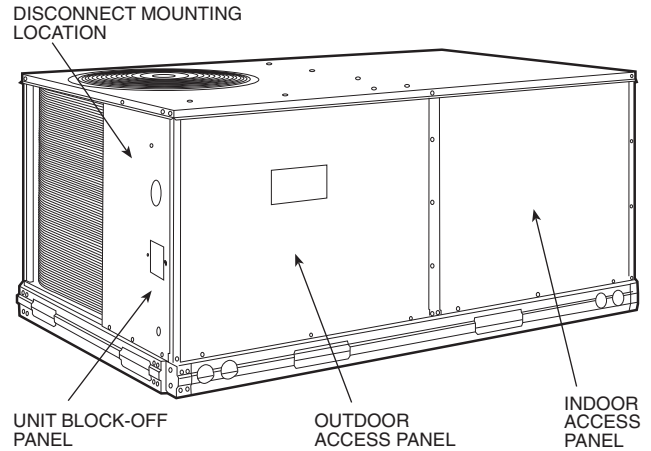
**Electric Heaters**

50LC units may be equipped with factory-installed or field-installed electric heaters. The heaters are modular in design, with heater frames holding open coil resistance wires strung through

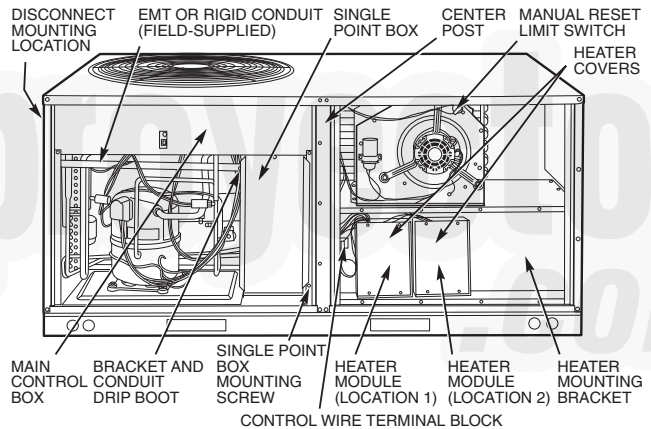
ceramic insulators, line-break limit switches and a control contactor. One or two heater modules may be used in a unit.

Heater modules are installed in the compartment below the indoor (supply) fan outlet. Access is through the indoor access panel. Heater modules slide into the compartment on tracks along the bottom of the heater opening. See Fig. 41-43.

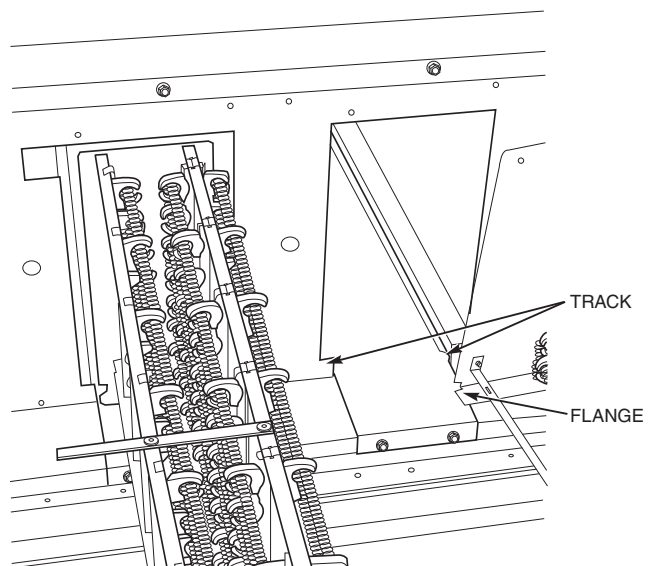
Not all available heater modules may be used in every unit. Use only those heater modules that are UL listed for use in a specific size unit. Refer to the label on the unit cabinet for the list of approved heaters.



**Fig. 41 — Typical Access Panel Location (3 to 5 Ton)**



**Fig. 42 — Typical Component Location**



**Fig. 43 — Typical Module Installation**



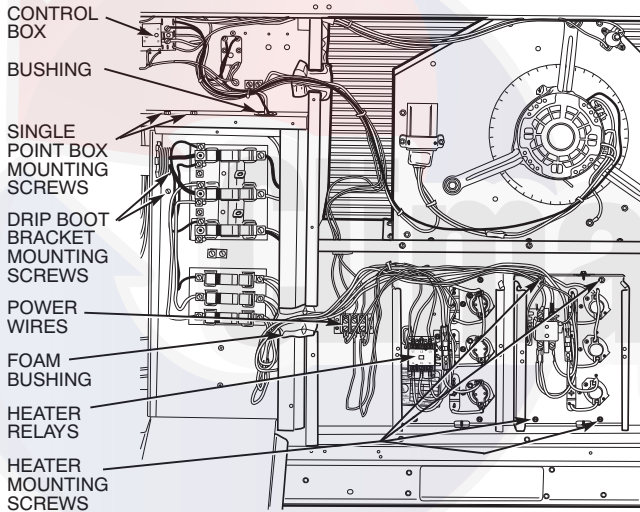
## SINGLE POINT BOXES AND SUPPLEMENTARY FUSES

When the unit MOCP device value exceeds 60-A, unit-mounted supplementary fuses are required for each heater circuit. These fuses are included in accessory single point boxes, with power distribution and fuse blocks. The single point box will be installed directly under the unit control box, just to the left of the partition separating the indoor section (with electric heaters) from the outdoor section. The single point box has a hinged access cover. See Fig. 44. The single point box also includes a set of power taps and pigtailed to complete the wiring between the single point box and the unit's main control box terminals. Refer to the accessory heater and single point box installation instructions for details on tap connections or field installed electric heat accessory.

All fuses on 50LC units are 60-A. (Note that all heaters are qualified for use with a 60-A fuse, regardless of actual heater ampacity, so only 60-A fuses are necessary.)

## SINGLE POINT BOXES WITHOUT FUSES

Some unit heater applications not requiring supplemental fuses require a special single point box without any fuses. The accessory single point boxes contain a set of power taps and pigtailed to complete the wiring between the single point box and the unit's main control box terminals. Refer to accessory heater and single point box installation instructions for details on tap connections or field installed electric heat accessory.

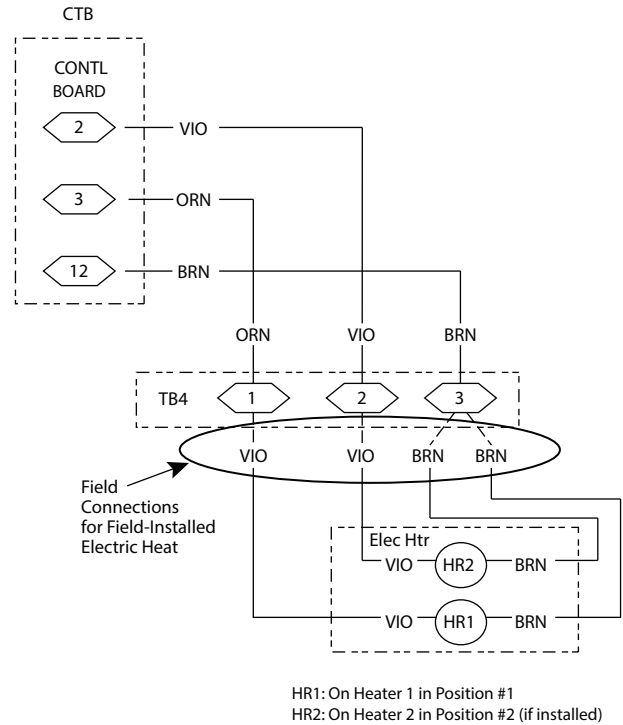


**Fig. 44 — Typical Single Point Installation**

## LOW-VOLTAGE CONTROL CONNECTIONS

### All units except size 06, 575-v

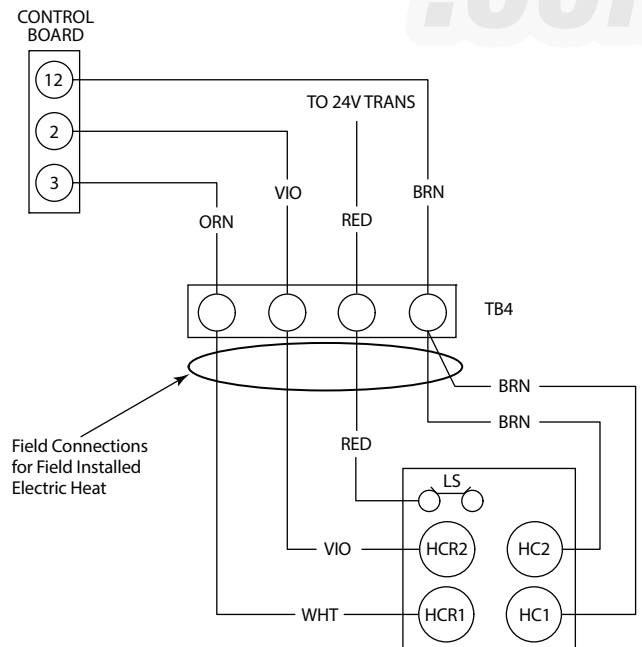
Pull the low-voltage control leads from the heater module(s) - VIO and BRN (two of each if two modules are installed; identify for Module #1) - to the 4-pole terminal board TB4 located on the heater bulkhead to the left of Heater #1. Connect the VIO lead from Heater #1 to terminal TB4-1. For 2 stage heating, connect the VIO lead from Heater #2 to terminal TB4-2. For 1 stage heating with 2 heater modules, connect the VIO lead from both Heater #1 and #2 to terminal TB4-1. Connect both BRN leads to terminal TB4-3. See Fig. 45.



**Fig. 45 — Accessory Electric Heater Control Connections (all units except size 06, 575-v) - 2 Stage Heat Shown**

### Size 06, 575-v units only

Pull the low-voltage control leads from the heater module(s) - VIO, WHT and BRN (two of each if two modules are installed; identify for Module #1) - to the 4-pole terminal board TB4 located on the heater bulkhead to the left of Heater #1. Connect the WHT lead from Heater #1 to TB4 where ORN is. For 2 stage heating, connect the VIO lead from Heater #2 to the terminal that has VIO from the unit. For 1 stage heating with 2 heater modules, connect the VIO lead from Heater #2 to the same terminal with WHT lead from Heater #1 (see Fig. 46).



**Fig. 46 — Accessory Electric Heater Control Connections (Size 06, 575-v only) - 2 Stage Heat Shown**

## Humidi-MiZer® Control Connections

NOTE: It is suggested to ensure the Auto-Changeover function of an installed thermostat is enabled when used in conjunction with the Humidi-MiZer Adaptive Dehumidification system.

### HUMIDI-MIZER – SPACE RH CONTROLLER

The Humidi-MiZer dehumidification system requires a field-supplied and field-installed space relative humidity control device. This device may be a separate humidistat control (contact closes on rise in space RH above control setpoint) (see Fig. 47) or a combination thermostat-humidistat control device such as Carrier's EDGE® Pro Thermidistat with isolated contact set for dehumidification control (see Fig. 48). The humidistat is normally used in applications where a temperature control is already provided (units with SystemVu™ or RTU Open controls).

To connect the Carrier humidistat (HL38MG029):

1. Route the humidistat 2-conductor cable (field-supplied) through the hole provided in the unit corner post.
2. Feed wires through the raceway built into the corner post (see Fig. 40) to the 24-v barrier located on the left side of the control box. The raceway provides the UL-required clearance between high-voltage and low-voltage wiring.
3. Use wire nuts to connect humidistat cable to the leads in the low-voltage wiring (as shown in Fig. 49), connecting PKN to PNK and PNK/BLK to PNK/BLK.

To connect the Thermidistat device (33CS2PPRH-03):

1. Route the Thermidistat multi-conductor thermostat cable (field-supplied) through the hole provided in the unit corner post.
2. Feed wires through the raceway built into the corner post (see Fig. 40) to the 24-v barrier located on the left side of the control box. The raceway provides the UL-required clearance between high-voltage and low-voltage wiring.
3. The Thermidistat has dry contacts at terminals D1 and D2 for dehumidification operation (see Fig. 50). The dry contacts must be wired between CTB terminal R and the PNK/BLK lead to the LTLO switch with field-supplied wire nuts. Refer to the installation instructions included with the Carrier Edge Thermidistat device for more information.

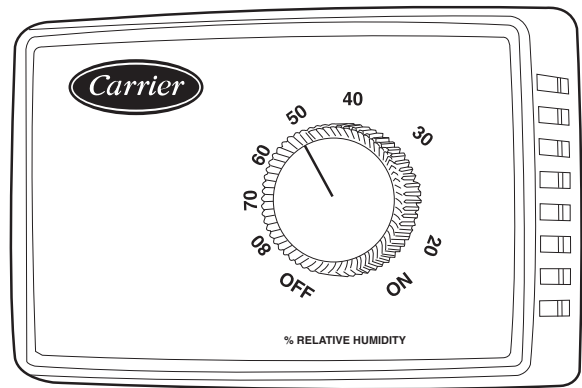


Fig. 47 — Accessory Field-Installed Humidistat



Fig. 48 — Edge® Pro Thermidistat

### EconoMi\$er X (Factory-Installed Option)

For details on operating 50LC units equipped with the factory-installed EconoMi\$er X option, refer to *EconoMi\$er X Factory-Installed Option Low Leak Economizer for 2 Speed SAV™ (Staged Air Volume) Systems*.

### SystemVu™ Controller (Factory-Installed Option)

For details on operating 50LC units equipped with the factory-installed SystemVu control option refer to *48/50LC 04-26 Single Package Rooftop Units with SystemVu Controls Version 2.X Controls, Start-up, Operation and Troubleshooting* manual.

### RTU Open Controller (Factory-Installed Option)

For details on operating 50LC\*04-06 units equipped with the factory-installed RTU Open controller option, refer to the *Factory Installed Option RTU Open Multi-Protocol Controller Controls, Start-Up, Operation, Troubleshooting* manual.

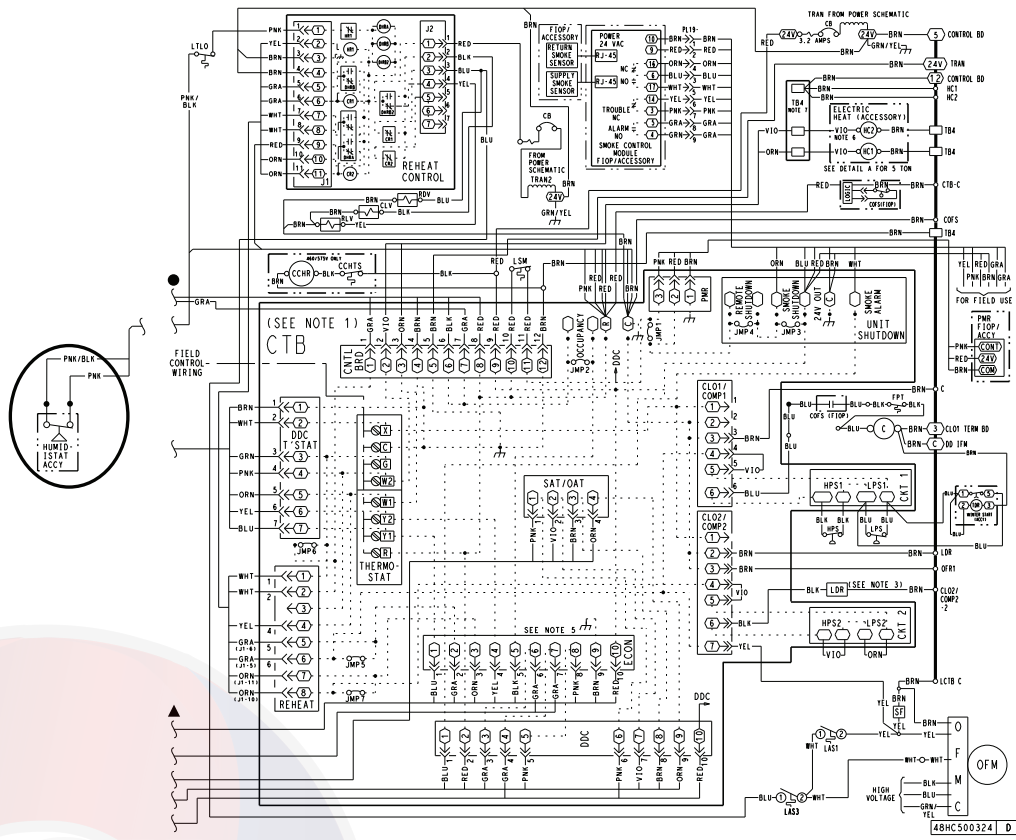
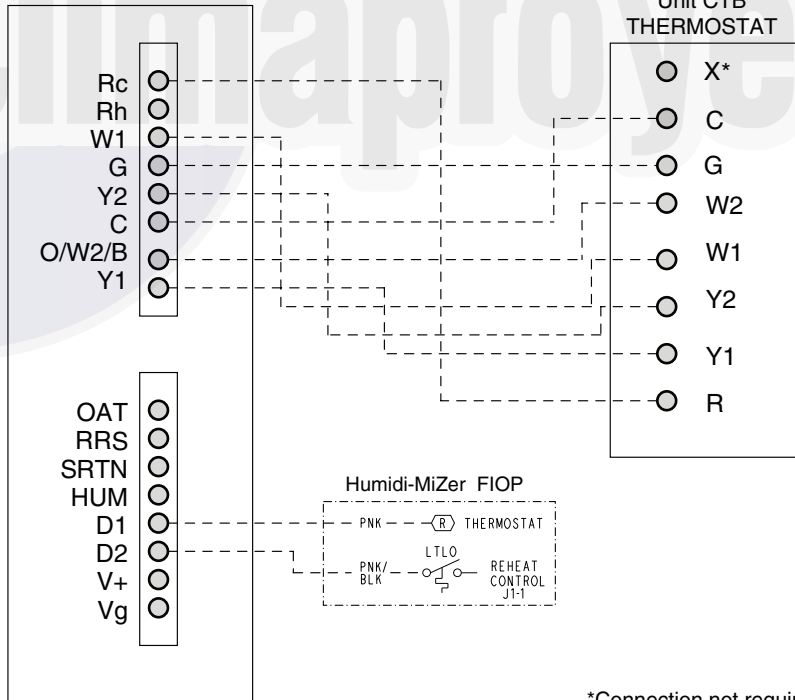


Fig. 49 — Typical Humidi-MiZer® Adaptive Dehumidification System Humidistat Wiring

Edge Programmable Thermostat



\*Connection not required.

Fig. 50 — Typical Rooftop Unit with Humidi-MiZer Adaptive Dehumidification System with Edge® Pro Thermidistat Device



## REHEAT MODES

Dehumidification (reheat) is a cooling mode function. Refer to Cooling Operation for cooling mode control. With Humidi-MiZer units, there are three additional HVAC Mode (HVAC) expanded texts available for the user: Reheat1, Reheat2, and Reheat1/Reheat2. Selection of the reheat mode for each refrigerant circuit is determined by the dehumidification demand and the cooling demand. Table 3 shows the corresponding circuit mode and output status for the different demand combinations. Units with multiple circuits can operate with a combination of Reheat1 and Reheat2 circuits, as determined by the amount of space cooling demand.

**NOTE:** Compressor staging control for Humidi-MiZer units requires that circuit A always operates when circuit B is on. This applies to normal operation, service test, and for control alarm responses. This operation difference is required due to the fact that the Motormaster outdoor fan control senses circuit A only. Operation of the revised refrigerant circuit for each mode is described below.

### Normal Cooling

For 50LC04-6 units, refrigerant flows from the outdoor condenser through the normally open Cooling Liquid Valve (CLV)

to the expansion device. Reheat Liquid Valve (RLV) and Reheat Discharge Valve (RDV) are closed. (See Fig. 51.)

### Reheat 1 (Subcooling Mode)

This mode increases latent cooling and decreases sensible cooling compared to normal cooling.

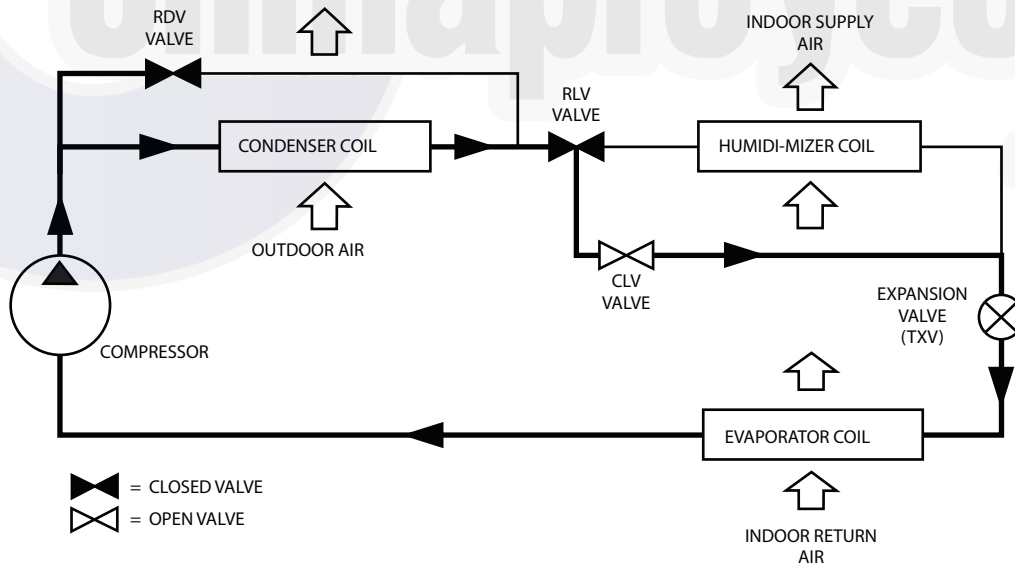
For 50LC04-6 units, refrigerant flows from the outdoor condenser, through the normally open Reheat Liquid Valve (RLV), and through the reheat condenser coil to the expansion device. Cooling Liquid Valve (CLV) and Reheat Discharge Valve (RDV) are closed. (See Fig. 52.)

### Reheat 2 (Hot Gas Reheat Mode)

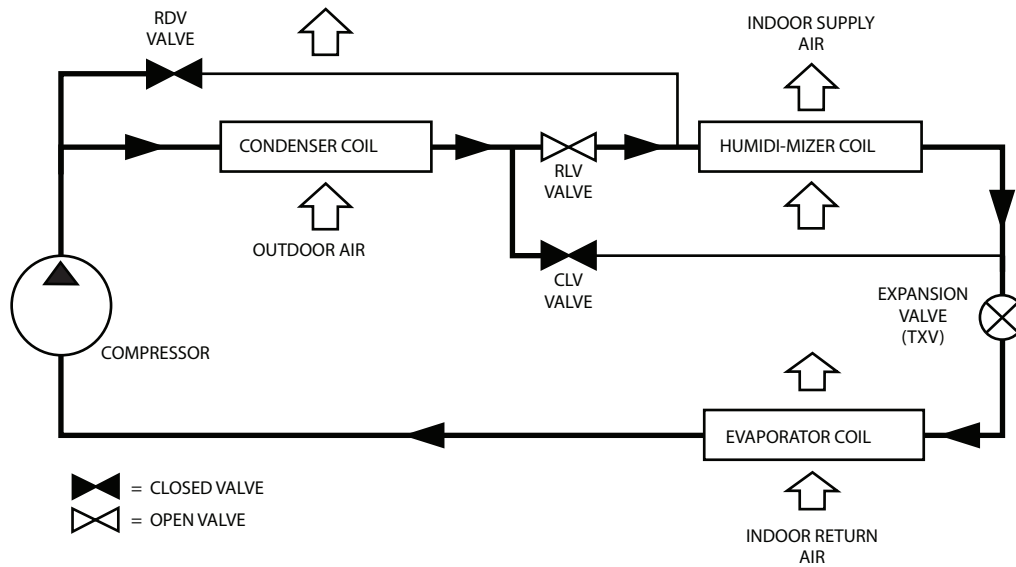
This mode provides maximum latent cooling with little to no sensible capacity. This mode can operate to provide dehumidification when there is no cooling demand. Similar to Reheat 1 mode, refrigerant flows from the outdoor condenser, through the normally open Reheat Liquid Valve (RLV1), or through the energized 3-way Liquid Diverter Valve (LDV), and through the reheat condenser coil to the expansion device. Reheat Discharge Valve (RDV) is open, which provides some compressor discharge gas to the reheat condenser to further increase the reheat of the evaporator air stream (See Fig. 53).

**Table 3 — Control Modes with Humidi-MiZer System  
Output and Valve States versus Circuit Mode**

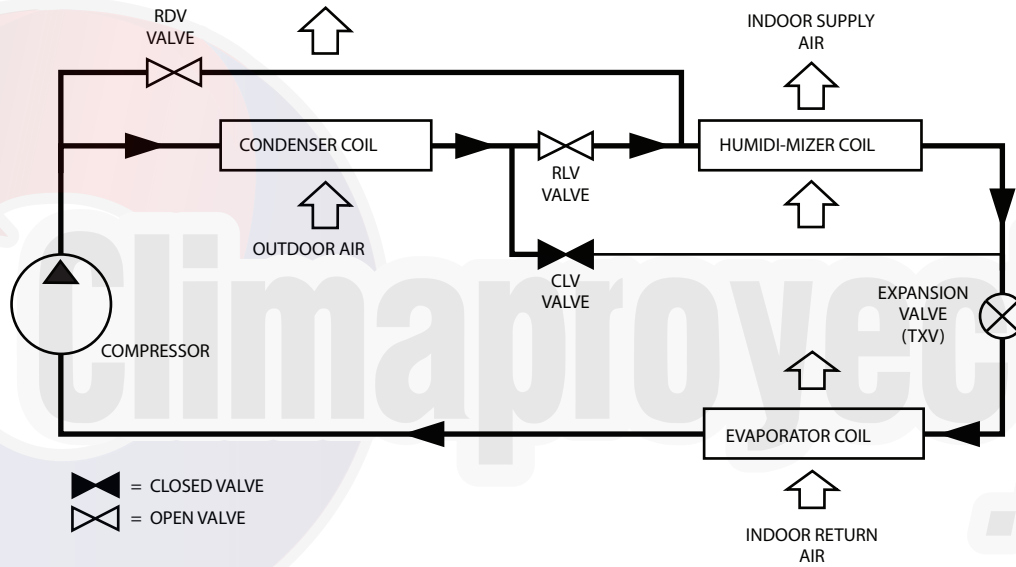
DEMAND AND MODE			OUTPUTS			50LC 04-06 VALVES		
Space Humidity	Circuit Cooling Demand	Circuit Mode	Circuit Compressor	Cooling Reheat Control	Reheat 2 Valve	CLV	RLV	RDV
—	—	No power	Off	Off	Off	Off (Open)	Off (Open)	Off (Closed)
Low	No	Off	Off	Off	Off	Off (Open)	On (Closed)	Off (Closed)
Low	Yes	Cool	On	Off	Off	Off (Open)	On (Closed)	Off (Closed)
High	Yes	Reheat 1	On	On	Off	On (Closed)	Off (Open)	Off (Closed)
High	No	Reheat 2	On	On	On	On (Closed)	Off (Open)	On (Open)



**Fig. 51 — Normal Cooling Mode — Humidi-MiZer System**



**Fig. 52 — Subcooling Mode (Reheat 1) — Humidi-MiZer System**



**Fig. 53 — Hot Gas Reheat Mode (Reheat 2) — Humidi-MiZer System**

## Smoke Detectors

Smoke detectors are available as factory-installed options on 50LC models. Smoke detectors may be specified for supply air only, for return air without or with economizer, or in combination of supply air and return air. All components necessary for operation are factory-provided and mounted. The unit is factory-configured for immediate smoke detector shutdown operation; additional wiring or modifications to unit terminal board may be necessary to complete the unit and smoke detector configuration to meet project requirements.

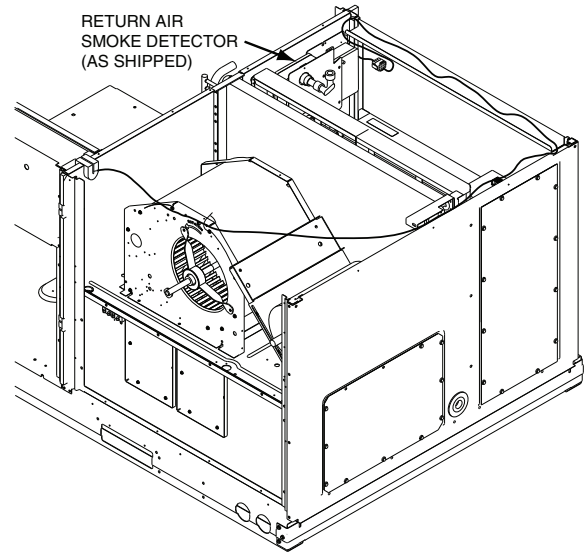
Units equipped with factory-optional return air smoke detectors require a relocation of the sensor module at unit installation. See Fig. 54 for the as-shipped location.

### COMPLETING INSTALLATION OF RETURN AIR SMOKE SENSOR

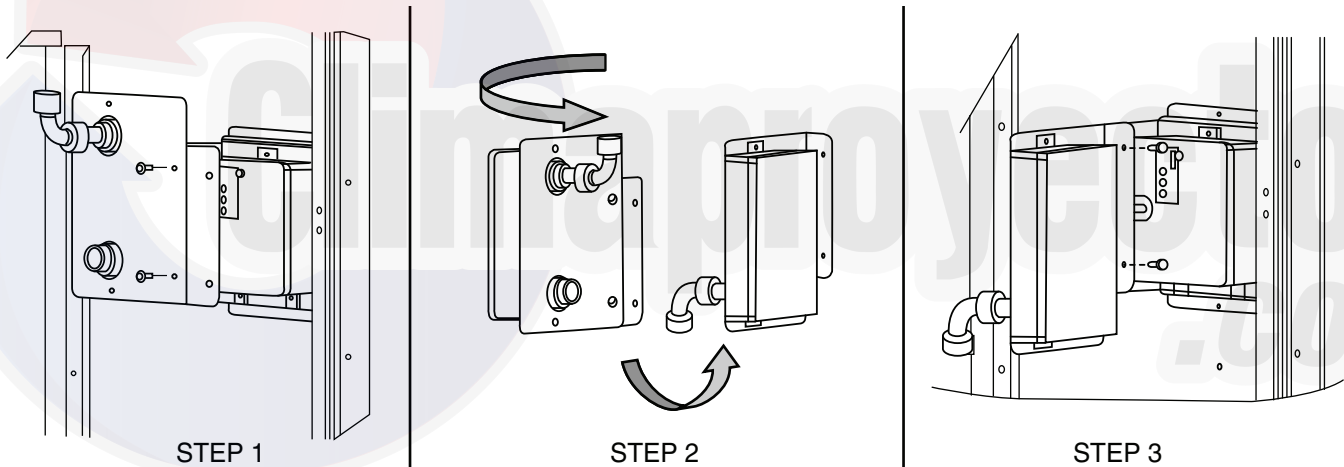
1. Unscrew the two screws holding the return air smoke detector assembly. See Fig. 55, Step 1.
2. Save the screws.
3. Turn the assembly 90 degrees and then rotate end to end. Make sure that the elbow fitting is pointing down. See Fig. 55, Step 2.
4. Screw the sensor and detector plate into its operating position using screws from Step 1. See Fig. 55, Step 3.
5. Connect the flexible tube on the sampling inlet to the sampling tube on the basepan.

### ADDITIONAL APPLICATION DATA

Refer to the application data sheet titled *Factory-Installed Smoke Detector, for Small and Medium Rooftop Units 2 to 25 Tons* for discussions on additional control features of these smoke detectors including multiple unit coordination.



**Fig. 54 — Return Air Smoke Detector; Shipping Position**



**Fig. 55 — Completing Installation of Return Air Smoke Sensor**

## Step 12 — Adjust Factory-Installed Options

### SMOKE DETECTORS

Smoke detector(s) will be connected at the Central Terminal Board (CTB), at terminals marked “Smoke Shutdown”. Remove jumper JMP 3 when ready to energize unit.

## Step 13 — Install Accessories

Available accessories include:

- Curb
- Thru-base connection kit (must be installed before unit is set on curb)
- Electric heaters and single-point connection kits
- EconoMi\$er® X (with control)
- EconoMi\$er2 (without control/for external signal)
- Power Exhaust
- Differential dry-bulb sensor (EconoMi\$er2)
- Outdoor enthalpy sensor
- Differential enthalpy sensor
- CO<sub>2</sub> sensor
- Louvered hail guard
- Phase monitor control

Refer to separate installation instructions for information on installing these accessories.

## Step 14 — Check Belt Tension

Measure the belt span length as shown in Fig. 56. Calculate the required deflection by multiplying the belt span length by  $\frac{1}{64}$ . For example, if the belt span length is 32 inches:

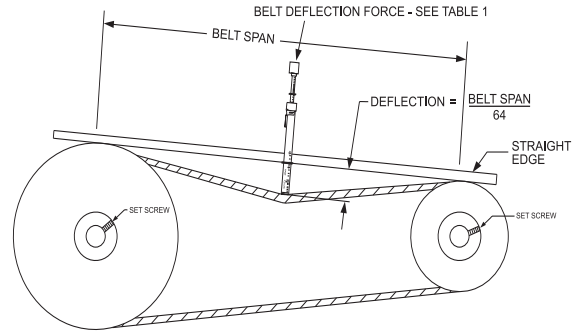
$$32 \times \frac{1}{64} = \frac{1}{2}\text{-in. deflection.}$$

### BELT FORCE — DEFLECTION METHOD

Check the belt tension with a spring-force belt force deflection gage (available from drive belt manufacturer).

1. Place a straightedge along the belt between the two pulleys. Measure the distance between the motor shaft and the blower shaft.
2. Set the tension gage to the desired tension (see Table 1 in Fig. 56). Place the large O-ring at that point.
3. Press the tension checker downward on the belt until the large O-ring is at the bottom of the straightedge.
4. Adjust the belt tension as needed.

Adjust belt tension by loosening the motor mounting plate front bolts and rear bolt (see Fig. 57) and slide the plate towards the fan (to reduce tension) or away from the fan (to increase tension). Ensure the blower shaft and motor shaft are parallel to each other (pulleys aligned). Tighten all bolts securely when finished.



BELT CROSS SECTION	SMALLEST SHEAVE DIAMETER	BELT DEFLECTION FORCE (LBS)			
		UNNOTCHED BELTS		NOTCHED BELTS	
		USED	NEW	USED	NEW
A, AX	3.0-3.6	3.7	5.5	4.1	6.1
	3.8-4.8	4.5	6.8	5.0	7.4
	5.0-7.0	5.4	8.0	5.7	8.4
B, BX	3.4-4.2	—	—	4.9	7.2
	4.4-5.6	5.3	7.9	7.1	10.5
	5.8-8.6	6.3	9.4	8.5	12.6

Table 1

BELT CONDITION	TENSION FORCE IN BELT (LBS)
New	100
Used	80

Table 2

Fig. 56 — V-Belt Force Label

### BELT TENSION METHOD

Requires belt tension gage that measures tension in belt in units of lbs force.

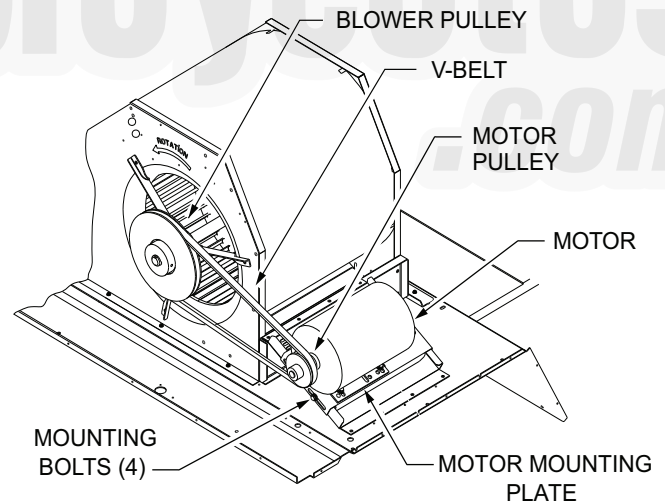


Fig. 57 — Belt Drive Motor Mounting

## Pre-Start and Start-Up

This completes the mechanical installation of the unit. Refer to the unit’s Service Manual for detailed Pre-Start and Start-Up instructions. Download the latest versions from HVAC Partners ([www.hvacpartners.com](http://www.hvacpartners.com)).

## APPENDIX A — VFD OPERATION WITH REMOTE KEYPAD

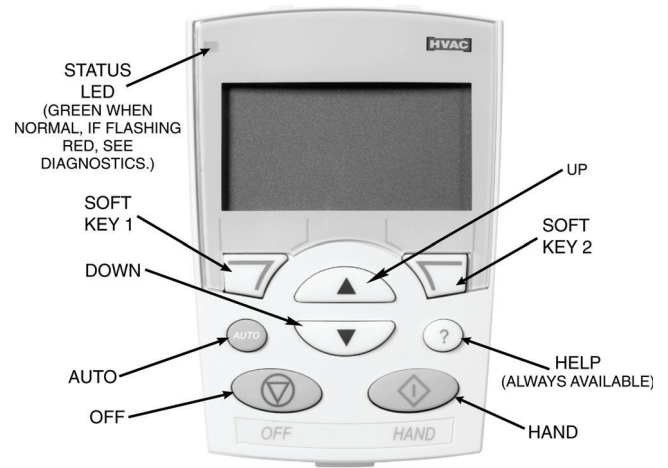
All 50LC size 04-06 units are equipped with a VFD (Variable Frequency Drive) to automatically adjust the indoor fan motor speed in sequence with the unit's ventilation, cooling and heating operation. The VFD keypad is included as standard on electro-mechanical and RTU Open models. See Fig. B for location of the VFD and the VFD keypad in these units.

NOTE: SystemVu™ models do not include the VFD keypad as VFD control operation is accessed through the SystemVu controls.

The VFD keypad is shown in Fig. A. The function of SOFT KEYS 1 and 2 change depending on what is displayed on the screen. The function of SOFT KEY 1 matches the word in the lower left-hand box on the display screen. The function of SOFT KEY 2 matches the word in the lower right-hand box on the display screen. If the box is empty, then the SOFT KEY does not have a function on that specific screen. The UP and DOWN keys are used to navigate through the menus. The OFF key is used to turn off the VFD. The AUTO key is used to change control of the drive to automatic control. The HAND key is used to change control of the drive to local (hand held) control. The HELP button is used to access the help screens.

For the VFD to operate on the units covered by this document, the drive must be set in AUTO mode. The word "AUTO" will appear in the upper left hand corner of the VFD display. Press the AUTO button to set the drive in AUTO mode.

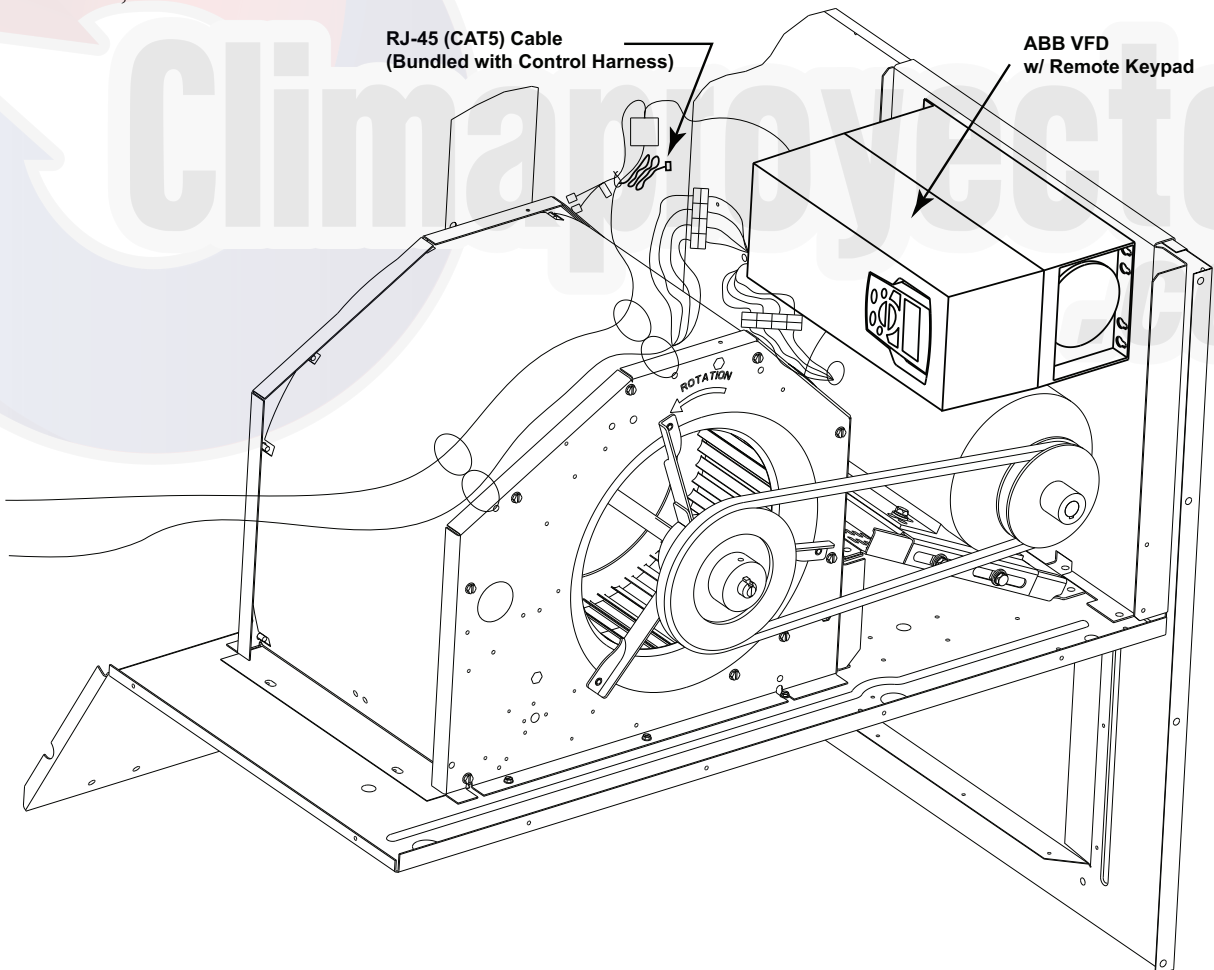
Use the RJ-45 (CAT5) cable (bundled with the Control Harness - see Fig. A) to provide easier access for using the VFD Remote Keypad. The cable's length is long enough to route it through to the unit's control box, if desired.



**Fig. A — VFD Keypad**

### To Connect the VFD Keypad using the RJ-45 Cable

1. Remove the keypad from the front of the VFD.
2. Remove the RJ-45 adapter from the back of the remote keypad and insert the adapter into the RJ-45 port on the front of the VFD.
3. Separate the RJ-45 (CAT5) cable from the control harness.
4. Use the CAT5 cable to connect the remote keypad to the VFD.



**Fig. B — Location of VFD in 50LC 04-06 Units**



## APPENDIX A — VFD OPERATION WITH REMOTE KEYPAD

### Start Up with Assistant

Initial start-up has been performed at the factory. Use of the start up assistant will override factory VFD configurations. **DO NOT USE THE START-UP ASSISTANT ON THESE LC UNITS!**

#### START UP BY CHANGING PARAMETERS INDIVIDUALLY

Initial start-up is performed at the factory. To start up the VFD by changing individual parameters, perform the following procedure:

1. Select MENU (SOFT KEY 2). The Main menu will be displayed.
2. Use the UP or DOWN keys to highlight PARAMETERS on the display screen and press ENTER (SOFT KEY 2).
3. Use the UP or DOWN keys to highlight the desired parameter group and press SEL (SOFT KEY 2).
4. Use the UP or DOWN keys to highlight the desired parameter and press EDIT (SOFT KEY 2).
5. Use the UP or DOWN keys to change the value of the parameter.
6. Press SAVE (SOFT KEY 2) to store the modified value. Press CANCEL (SOFT KEY 1) to keep the previous value. Any modifications that are not saved will not be changed.
7. Choose another parameter or press EXIT (SOFT KEY 1) to return to the listing of parameter groups. Continue until all the parameters have been configured and then press EXIT (SOFT KEY 1) to return to the main menu.

NOTE: The current parameter value appears above the highlight parameter. To view the default parameter value, press the UP and DOWN keys simultaneously. To restore the default factory settings, select the application macro “HVAC Default.”

### VFD Modes

The VFD has several different modes for configuring, operating, and diagnosing the VFD. The modes are:

- Standard Display model—shows drive status information and operates the drive
- Parameters mode—edits parameter values individually
- Start-up Assistant mode—guides the start up and configuration. **DO NOT USE THE START-UP ASSISTANT ON THESE LC UNITS!**
- Changed Parameters mode—shows all changed parameters
- Drive Parameter Backup mode—stores or uploads the parameters
- Clock Set mode—sets the time and date for the drive
- I/O Settings mode—checks and edits the I/O settings

#### STANDARD DISPLAY MODE

Use the standard display mode to read information on the drive status and operate the drive. To reach the standard display mode, press EXIT until the LCD display shows status information as described below. (See Fig. C)

The top line of the LCD display shows the basic status information of the drive. The HAND icon indicates that the drive control is local from the control panel. The AUTO icon indicates that the drive is in remote control mode, such as the basic I/O or field bus.

The arrow icon indicates the drive and motor rotation status. A rotating arrow (clockwise or counterclockwise) indicates that the drive is running and at set point and the shaft direction is forward or reverse. A rotating blinking arrow indicates that the drive is running but not at set point. A stationary arrow indicates that the drive is stopped. For the units covered in this manual, the correct display rotation is clockwise.

The upper right corner shows the frequency set point that the drive will maintain.

Using parameter group 34, the middle of the LCD display can be configured to display 3 parameter values. The default display shows parameters 0103 (OUTPUT FREQ) in percent speed, 0104 (CURRENT) in amperes, and 0120 (All) in voltage DC.

The bottom corners of the LCD display show the functions currently assigned to the two soft keys. The lower middle displays the current time (if configured to show the time).

The first time the drive is powered up, it is in the OFF mode. To switch to local hand-held control and control the drive using the control panel, press and hold the HAND button. Pressing the HAND button switches the drive to hand control while keeping the drive running. Press the AUTO button to switch to remote input control. To start the drive press the HAND or AUTO buttons, to stop the drive press the OFF button.

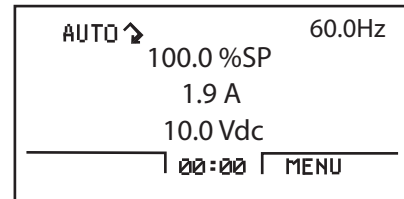


Fig. C — Standard Display Example

To adjust the speed in HAND mode, press the UP or DOWN buttons (the reference changes immediately). The reference can be modified in the local control (HAND) mode, and can be parameterized (using Group 11 reference select) to also allow modification in the remote control mode.

#### PARAMETERS MODE

The Parameters mode is used to change the parameters on the drive. To change parameters, perform the following procedure. See Tables A-C for a listing of the VFD parameters per motor and VFD drive models:

1. Select MENU (SOFT KEY 2). The Main menu will be displayed.
2. Use the UP or DOWN keys to highlight PARAMETERS on the display screen and press ENTER (SOFT KEY 2).
3. Use the UP or DOWN keys to highlight the desired parameter group and press SEL (SOFT KEY 2).
4. Use the UP or DOWN keys to highlight the desired parameter and press EDIT (SOFT KEY 2).
5. Use the UP or DOWN keys to change the value of the parameter.
6. Press SAVE (SOFT KEY 2) to store the modified value. Press CANCEL (SOFT KEY 1) to keep the previous value. Any modifications that are not saved will not be changed.
7. Choose another parameter or press EXIT (SOFT KEY 1) to return to the listing of parameter groups. Continue until all the parameters have been configured and then press EXIT (SOFT KEY 1) to return to the main menu.

NOTE: The current parameter value appears above the highlight parameter. To view the default parameter value, press the UP and DOWN keys simultaneously. To restore the default factory settings, select the Carrier application macro.

#### CHANGED PARAMETERS MODE

The Changed Parameters mode is used to view and edit recently changed parameters on the drive. To view the changed parameters, perform the following procedure:

1. Select MENU (SOFT KEY 2). The Main menu will be displayed.
2. Use the UP or DOWN keys to highlight CHANGED PAR on the display screen and press ENTER (SOFT KEY 2). A list of the recently changed parameters will be displayed.

## APPENDIX A — VFD OPERATION WITH REMOTE KEYPAD

3. Use the UP or DOWN keys to highlight the desired parameter group and press EDIT (SOFT KEY 2) to change the parameter if desired.
4. Press EXIT (SOFT KEY 1) to exit the Changed Parameters mode.

### DRIVE PARAMETER BACKUP MODE

The drive parameter back up mode is used to export the parameters from one drive to another. The parameters can be uploaded from a VFD to the removable control panel. The control panel can then be transferred to another drive and the parameters downloaded into memory.

Depending on the motor and application, there are two options available. The first option is to download all parameters. This copies both application and motor parameters to the drive from the control panel. This is recommended when using the same application for drives of the same size. This can also be used to create a backup of the parameters group for the drive.

The second option downloads only the application parameters to the drive. This is recommended when using the same application for drives of different sizes.

### UPLOAD ALL PARAMETERS

To upload and store parameters in the control panel from the VFD, perform the following procedure:

1. Select MENU (SOFT KEY 2). The Main menu will be displayed.
2. Use the UP or DOWN keys to highlight PAR BACKUP on the display screen and press ENTER (SOFT KEY 2).
3. Use the UP or DOWN keys to highlight UPLOAD TO PANEL and press SEL (SOFT KEY 2).
4. The text “Copying Parameters” will be displayed with a progress indicator. To stop the process, select ABORT (SOFT KEY 1).
5. When the upload is complete, the text “Parameter upload successful” will be displayed.
6. The display will then return to the PAR BACKUP menu. Select EXIT (SOFT KEY 1) to return to the main menu.
7. The control panel can now be disconnected from the drive.

### DOWNLOAD ALL PARAMETERS

To download all parameters from the control panel to the VFD, perform the following procedure:

1. Install the control panel with the correct parameters onto the VFD.
2. Select MENU (SOFT KEY 2). The Main menu will be displayed.
3. Use the UP or DOWN keys to highlight PAR BACKUP on the display screen and press ENTER (SOFT KEY 2).
4. Use the UP or DOWN keys to highlight DOWNLOAD TO DRIVE ALL and press SEL (SOFT KEY 2).
5. The text “Restoring Parameters” will be displayed with a progress indicator. To stop the process, select ABORT (SOFT KEY 1).
6. When the download is complete, the text “Parameter download successful” will be displayed.
7. The display will then return to the PAR BACKUP menu. Select EXIT (SOFT KEY 1) to return to the main menu.
8. The control panel can now be disconnected from the drive.

### DOWNLOAD APPLICATION PARAMETERS

To download application parameters only to the control panel from the VFD, perform the following procedure:

1. Install the control panel with the correct parameters onto the VFD.

2. Select MENU (SOFT KEY 2). The Main menu will be displayed.
3. Use the UP or DOWN keys to highlight PAR BACKUP on the display screen and press ENTER (SOFT KEY 2).
4. Use the UP or DOWN keys to highlight DOWNLOAD APPLICATION and press SEL (SOFT KEY 2).
5. The text “Downloading Parameters (partial)” will be displayed with a progress indicator. To stop the process, select ABORT (SOFT KEY 1).
6. When the download is complete, the text “Parameter download successful” will be displayed.
7. The display will then return to the PAR BACKUP menu. Select EXIT (SOFT KEY 1) to return to the main menu.
8. The control panel can now be disconnected from the drive.

### CLOCK SET MODE

The clock set mode is used for setting the date and time for the internal clock of the VFD. In order to use the timer functions of the VFD control, the internal clock must be set. The date is used to determine weekdays and is visible in the fault logs.

To set the clock, perform the following procedure:

1. Select MENU (SOFT KEY 2). The Main menu will be displayed.
2. Use the UP or DOWN keys to highlight CLOCK SET on the display screen and press ENTER (SOFT KEY 2). The clock set parameter list will be displayed.
3. Use the UP or DOWN keys to highlight CLOCK VISIBILITY and press SEL (SOFT KEY 2). This parameter is used to display or hide the clock on the screen. Use the UP or DOWN keys to change the parameter setting. Press OK (SOFT KEY 2) to save the configuration and return to the Clock Set menu.
4. Use the UP or DOWN keys to highlight SET TIME and press SEL (SOFT KEY 2). Use the UP or DOWN keys to change the hours and minutes. Press OK (SOFT KEY 2) to save the configuration and return to the Clock Set menu.
5. Use the UP or DOWN keys to highlight TIME FORMAT and press SEL (SOFT KEY 2). Use the UP or DOWN keys to change the parameter setting. Press OK (SOFT KEY 2) to save the configuration and return to the Clock Set menu.
6. Use the UP or DOWN keys to highlight SET DATE and press SEL (SOFT KEY 2). Use the UP or DOWN keys to change the day, month, and year. Press OK (SOFT KEY 2) to save the configuration and return to the Clock Set menu.
7. Use the UP or DOWN keys to highlight DATE FORMAT and press SEL (SOFT KEY 2). Use the UP or DOWN keys to change the parameter setting. Press OK (SOFT KEY 2) to save the configuration and return to the Clock Set menu.
8. Press EXIT (SOFT KEY 1) twice to return to the main menu.

### I/O SETTINGS MODE

The I/O Settings mode is used for viewing and editing the I/O settings.

To configure the I/O settings, perform the following procedure:

1. Select MENU (SOFT KEY 2). The Main menu will be displayed.
2. Use the UP or DOWN keys to highlight I/O SETTINGS on the display screen and press ENTER (SOFT KEY 2). The I/O Settings parameter list will be displayed.
3. Use the UP or DOWN keys to highlight the desired I/O setting and press SEL (SOFT KEY 2).



## APPENDIX A — VFD OPERATION WITH REMOTE KEYPAD

4. Use the UP or DOWN keys to select the parameter to view. Press OK (SOFT KEY 2).
5. Use the UP or DOWN keys to change the parameter setting. Press SAVE (SOFT KEY 2) to save the configuration. Press CANCEL (SOFT KEY 1) to keep the previous value. Any modifications that are not saved will not be changed.
6. Press EXIT (SOFT KEY 1) twice to return to the main menu.

**Table A — 50LC 04 VFD Parameters**

		UNIT SIZE	50LC 04				
PARAMETER GROUP	PARAMETER NUMBER	Motor Description	1.7 HP 575-v	1.7 HP 208-230-v	1.7 HP 460-v	2.4 HP 575-v	2.4 HP 208-230-v
		Drive/Motor Voltage	575-v	208-230-v	460-v	575-v	208-230-v
		Motor Part Number	HD56FR579	HD56FR233	HD56FR463	HD56FE577	HD56FE653
		VFD Part Number	HK30WA048	HK30WA045	HK30WA046	HK30WA048	HK30WA001
		ABB Part Number	ACH550-CARUH-03A9-6	ACH550-CARUH-07A5-2	ACH550-CARUH-04A-4	ACH550-CARUH-03A9-6	ACH550-CARUH-012A-2
START-UP DATA	9902	Application Macro	(1) HVAC DEFAULT	(1) HVAC DEFAULT	(1) HVAC DEFAULT	(1) HVAC DEFAULT	(1) HVAC DEFAULT
	9905	Motor Nominal Voltage	575	230	460	575	230
	9906	Motor Nominal Current	3.1	5.8	2.9	3.4	7.9
	9907	Motor Nominal Frequency	60	60	60	60	60
	9908	Motor Nominal Speed	1725	1725	1725	1725	1725
	9909	Motor Nominal Power	1.7	1.7	1.7	2.4	2.4
START/STOP/DIR	1001	EXT1 Commands	(1) DI1	(1) DI1	(1) DI1	(1) DI1	(1) DI1
	1003	Direction	(1) Forward	(1) Forward	(1) Forward	(1) Forward	(1) Forward
REFERENCE SELECT	1103	REF1 Select	(1) AI1	(1) AI1	(1) AI1	(1) AI1	(1) AI1
	1104	REF1 Minimum	0 Hz	0 Hz	0 Hz	0 Hz	0 Hz
	1105	REF1 Maximum	60 Hz	60 Hz	60 Hz	60 Hz	60 Hz
CONSTANT SPEEDS	1201	Constant Speed Select	(8) DI2,3	(8) DI2,3	(8) DI2,3	(8) DI2,3	(8) DI2,3
	1202	Constant Speed 1	52.4	52.4	52.4	52.4	52.4
	1203	Constant Speed 2	60 Hz	60 Hz	60 Hz	60 Hz	60 Hz
	1204	Constant Speed 3	60 Hz	60 Hz	60 Hz	60 Hz	60 Hz
ANALOG INPUTS	1301	Minimum AI-1	20.00%	20.00%	20.00%	20.00%	20.00%
	1302	Maximum AI-1	100.00%	100.00%	100.00%	100.00%	100.00%
RELAY OUTPUTS	1401	Relay Output 1	(1) Ready	(1) Ready	(1) Ready	(1) Ready	(1) Ready
	1402	Relay Output 2	(2) Run	(2) Run	(2) Run	(2) Run	(2) Run
	1403	Relay Output 3	(16) FLT/ALARM	(16) FLT/ALARM	(16) FLT/ALARM	(16) FLT/ALARM	(16) FLT/ALARM
SYSTEM CONTROL	1604	Fault Reset Sel	(0) Keypad	(0) Keypad	(0) Keypad	(0) Keypad	(0) Keypad
	1608	Start Enable 1	(4) DI4	(4) DI4	(4) DI4	(4) DI4	(4) DI4
OVERRIDE	1701	Override Sel	(0) NOT SEL	(0) NOT SEL	(0) NOT SEL	(0) NOT SEL	(0) NOT SEL
	2003	Maximum Current	3.6	6.7	3.3	3.9	9.1
LIMITS	2007	Minimum Frequency	0.0 Hz	0.0 Hz	0.0 Hz	0.0 Hz	0.0 Hz
	2008	Maximum Frequency	60 Hz	60 Hz	60 Hz	60 Hz	60 Hz
	2101	Start Function	(1) AUTO	(1) AUTO	(1) AUTO	(1) AUTO	(1) AUTO
START/STOP	2102	Stop Function	(1) Coast	(1) Coast	(1) Coast	(1) Coast	(1) Coast
	2109	EM STOP Sel	(0) NOT SEL	(0) NOT SEL	(0) NOT SEL	(0) NOT SEL	(0) NOT SEL
	2201	Acc/Dec 1/2 Sel	(0) NOT SEL	(0) NOT SEL	(0) NOT SEL	(0) NOT SEL	(0) NOT SEL
ACCEL/DECCEL	2202	Accelerate Time	30.0 s	30.0 s	30.0 s	30.0 s	30.0 s
	2203	Decelerate Time	10.0 s	10.0 s	10.0 s	10.0 s	10.0 s
MOTOR	2606	Switching Frequency	4 KHz	4 KHz	4 KHz	4 KHz	4 KHz
	2607	Switching Frequency Control	(1) ON	(1) ON	(1) ON	(1) ON	(1) ON

**APPENDIX A — VFD OPERATION WITH REMOTE KEYPAD**

**Table A — 50LC 04 VFD Parameters (cont)**

		UNIT SIZE	50LC 04				
PARAMETER GROUP	PARAMETER NUMBER	Motor Description	1.7 HP 575-v	1.7 HP 208-230-v	1.7 HP 460-v	2.4 HP 575-v	2.4 HP 208-230-v
		Drive/Motor Voltage	575-v	208-230-v	460-v	575-v	208-230-v
		Motor Part Number	HD56FR579	HD56FR233	HD56FR463	HD56FE577	HD56FE653
		VFD Part Number	HK30WA048	HK30WA045	HK30WA046	HK30WA048	HK30WA001
		ABB Part Number	ACH550-CARUH-03A9-6	ACH550-CARUH-07A5-2	ACH550-CARUH-04A-4	ACH550-CARUH-03A9-6	ACH550-CARUH-012A-2
FAULT FUNCTIONS	3005	Motor Therm Prot	(1) Fault	(1) Fault	(1) Fault	(1) Fault	(1) Fault
	3006	Motor Thermal Time	1050 s	1050 s	1050 s	1050 s	1050 s
	3007	Motor Load Curve	100%	100%	100%	100%	100%
	3008	Zero Speed Load	%00705	%00705	%00705	%00705	%00705
	3009	Break Point Frequency	35 Hz	35 Hz	35 Hz	35 Hz	35 Hz
AUTOMATIC RESET	3104	AR Overcurrent	(0) DISABLE	(0) DISABLE	(0) DISABLE	(0) DISABLE	(0) DISABLE
	3105	AR Overvoltage	(1) ENABLE	(1) ENABLE	(1) ENABLE	(1) ENABLE	(1) ENABLE
	3106	AR Undervoltage	(1) ENABLE	(1) ENABLE	(1) ENABLE	(1) ENABLE	(1) ENABLE
EFB PROTOCOL	5301	EFB PROTOCOL ID	0601 (hex)	0601 (hex)	0601 (hex)	0601 (hex)	0601 (hex)
	5302	EFB STATION ID	41	41	41	41	41
	5303	EFB BAUD RATE	38400	38400	38400	38400	38400
	5304	EFB PARITY	8 NONE 1	8 NONE 1	8 NONE 1	8 NONE 1	8 NONE 1
	5305	EFB CTRL PROFILE	DCU PROFILE	DCU PROFILE	DCU PROFILE	DCU PROFILE	DCU PROFILE
OPTIONS	9802	COMM PROT SEL	6 (LEN)	6 (LEN)	6 (LEN)	6 (LEN)	6 (LEN)

**Table B — 50LC 04-06 Parameters**

		UNIT SIZE	50LC 04	50LC 05	50LC 06		
PARAMETER GROUP	PARAMETER NUMBER	Motor Description	2.4 HP 460-v	1.7 HP 575-v	1.7 HP 208-230-v	1.7 HP 460-v	2.4 HP 575-v
		Drive/motor Voltage	460-v	575-v	208-230-v	460-v	575-v
		Motor Part Number	HD56FE653	HD56FR579	HD56FR233	HD56FR463	HD56FE577
		VFD Part Number	HK30WA008	HK30WA048	HK30WA045	HK30WA046	HK30WA048
		ABB Part Number	ACH550-CARUH-06A9-4	ACH550-CARUH-03A9-6	ACH550-CARUH-07A5-2	ACH550-CARUH-04A1-4	ACH550-CARUH-03A9-6
START-UP DATA	9902	Application Macro	(1) HVAC DEFAULT	(1) HVAC DEFAULT	(1) HVAC DEFAULT	(1) HVAC DEFAULT	(1) HVAC DEFAULT
	9905	Motor Nominal Voltage	460	575	230	460	575
	9906	Motor Nominal Current	4.0	3.1	5.8	2.9	3.4
	9907	Motor Nominal Frequency	60	60	60	60	60
	9908	Motor Nominal Speed	1725	1725	1725	1725	1725
	9909	Motor Nominal Power	2.4	1.7	1.7	1.7	2.4
START/STOP/DIR	1001	EXT1 Commands	(1) DI1	(1) DI1	(1) DI1	(1) DI1	(1) DI1
	1003	Direction	(1) Forward	(1) Forward	(1) Forward	(1) Forward	(1) Forward
REFERENCE SELECT	1103	REF1 Select	(1) AI1	(1) AI1	(1) AI1	(1) AI1	(1) AI1
	1104	REF1 Minimum	0 Hz	0 Hz	0 Hz	0 Hz	0 Hz
	1105	REF1 Maximum	60 Hz	60 Hz	60 Hz	60 Hz	60 Hz

## APPENDIX A — VFD OPERATION WITH REMOTE KEYPAD

### Table B — 50LC 04-06 Parameters (cont)

		UNIT SIZE	50LC 04	50LC 05			50LC 06
PARAMETER GROUP	PARAMETER NUMBER	Motor Description	2.4 HP 460-v	1.7 HP 575-v	1.7 HP 208-230-v	1.7 HP 460-v	2.4 HP 575-v
		Drive/motor Voltage	460-v	575-v	208-230-v	460-v	575-v
		Motor Part Number	HD56FE653	HD56FR579	HD56FR233	HD56FR463	HD56FE577
		VFD Part Number	HK30WA008	HK30WA048	HK30WA045	HK30WA046	HK30WA048
		ABB Part Number	ACH550-CARUH-06A9-4	ACH550-CARUH-03A9-6	ACH550-CARUH-07A5-2	ACH550-CARUH-04A1-4	ACH550-CARUH-03A9-6
CONSTANT SPEEDS	1201	Constant Speed Select	(8) DI2,3	(8) DI2,3	(8) DI2,3	(8) DI2,3	(8) DI2,3
	1202	Constant Speed 1	52.4	42.6	42.6	42.6	42.6
	1203	Constant Speed 2	60 Hz	60 Hz	60 Hz	60 Hz	60 Hz
	1204	Constant Speed 3	60 Hz	60 Hz	60 Hz	60 Hz	60 Hz
ANALOG INPUTS	1301	Minimum AI-1	20.00%	20.00%	20.00%	20.00%	20.00%
	1302	Maximum AI-1	100.00%	100.00%	100.00%	100.00%	100.00%
RELAY OUTPUTS	1401	Relay Output 1	(1) Ready	(1) Ready	(1) Ready	(1) Ready	(1) Ready
	1402	Relay Output 2	(2) Run	(2) Run	(2) Run	(2) Run	(2) Run
	1403	Relay Output 3	(16) FLT/ALARM	(16) FLT/ALARM	(16) FLT/ALARM	(16) FLT/ALARM	(16) FLT/ALARM
SYSTEM CONTROL	1604	Fault Reset Sel	(0) Keypad	(0) Keypad	(0) Keypad	(0) Keypad	(0) Keypad
	1608	Start Enable 1	(4) DI4	(4) DI4	(4) DI4	(4) DI4	(4) DI4
OVERRIDE	1701	Override Sel	(0) NOT SEL	(0) NOT SEL	(0) NOT SEL	(0) NOT SEL	(0) NOT SEL
LIMITS	2003	Maximum Current	4.6	3.6	6.7	3.3	3.9
	2007	Minimum Frequency	0.0 Hz	0.0 Hz	0.0 Hz	0.0 Hz	0.0 Hz
	2008	Maximum Frequency	60 Hz	60 Hz	60 Hz	60 Hz	60 Hz
START/STOP	2101	Start Function	(1) AUTO	(1) AUTO	(1) AUTO	(1) AUTO	(1) AUTO
	2102	Stop Function	(1) Coast	(1) Coast	(1) Coast	(1) Coast	(1) Coast
	2109	EM STOP Sel	(0) NOT SEL	(0) NOT SEL	(0) NOT SEL	(0) NOT SEL	(0) NOT SEL
ACCEL/DECEL	2201	Acc/Dec 1/2 Sel	(0) NOT SEL	(0) NOT SEL	(0) NOT SEL	(0) NOT SEL	(0) NOT SEL
	2202	Accelerate Time	30.0 s	30.0 s	30.0 s	30.0 s	30.0 s
	2203	Decelerate Time	10.0 s	10.0 s	10.0 s	10.0 s	10.0 s
MOTOR	2606	Switching Frequency	4 KHz	4 KHz	4 KHz	4 KHz	4 KHz
	2607	Switching Frequency Control	(1) ON	(1) ON	(1) ON	(1) ON	(1) ON
FAULT FUNCTIONS	3005	Motor Therm Prot	(1) Fault	(1) Fault	(1) Fault	(1) Fault	(1) Fault
	3006	Motor Thermal Time	1050 s	1050 s	1050 s	1050 s	1050 s
	3007	Motor Load Curve	100%	100%	100%	100%	100%
	3008	Zero Speed Load	%00705	%00705	%00705	%00705	%00705
	3009	Break Point Frequency	35 Hz	35 Hz	35 Hz	35 Hz	35 Hz
AUTOMATIC RESET	3104	AR Overcurrent	(0) DISABLE	(0) DISABLE	(0) DISABLE	(0) DISABLE	(0) DISABLE
	3105	AR Overvoltage	(1) ENABLE	(1) ENABLE	(1) ENABLE	(1) ENABLE	(1) ENABLE
	3106	AR Undervoltage	(1) ENABLE	(1) ENABLE	(1) ENABLE	(1) ENABLE	(1) ENABLE
EFB PROTOCOL	5301	EFB PROTOCOL ID	0601 (hex)	0601 (hex)	0601 (hex)	0601 (hex)	0601 (hex)
	5302	EFB STATION ID	41	41	41	41	41
	5303	EFB BAUD RATE	38400	38400	38400	38400	38400
	5304	EFB PARITY	8 NONE 1	8 NONE 1	8 NONE 1	8 NONE 1	8 NONE 1
	5305	EFB CTRL PROFILE	DCU PROFILE	DCU PROFILE	DCU PROFILE	DCU PROFILE	DCU PROFILE
OPTIONS	9802	COMM PROT SEL	6 (LEN)	6 (LEN)	6 (LEN)	6 (LEN)	6 (LEN)

**APPENDIX A — VFD OPERATION WITH REMOTE KEYPAD**

**Table C — 50LC 05-06 VFD Parameters**

PARAMETER GROUP	PARAMETER NUMBER	UNIT SIZE	50LC 06		50LC 05/06		
		Motor Description	2.4 HP 208-230-v	2.4 HP 460-v	2.9 HP 208-230-v	2.9 HP 460-v	3.7 HP 575-v
PARAMETER GROUP	PARAMETER NUMBER	Drive/Motor Voltage	208-230-v	460-v	208-230-v	460-v	575-v
		Motor Part Number	HD56FE653	HD56FE653	HD58FE654	HD58FE654	HD58FE577
		VFD Part Number	HK30WA001	HK30WA008	HK30WA001	HK30WA008	HK30WA021
		ABB Part Number	ACH550-CARUH-012A-2	ACH550-CARUH-06A9-4	ACH550-CARUH-012A-2	ACH550-CARUH-06A9-4	ACH550-CARUH-06A1-6
		Application Macro	(1) HVAC DEFAULT	(1) HVAC DEFAULT	(1) HVAC DEFAULT	(1) HVAC DEFAULT	(1) HVAC DEFAULT
START-UP DATA	9902	Application Macro	(1) HVAC DEFAULT	(1) HVAC DEFAULT	(1) HVAC DEFAULT	(1) HVAC DEFAULT	(1) HVAC DEFAULT
	9905	Motor Nominal Voltage	230	460	230	460	575
	9906	Motor Nominal Current	7.9	4.0	9.2	4.6	4.2
	9907	Motor Nominal Frequency	60	60	60	60	60
	9908	Motor Nominal Speed	1725	1725	1725	1725	1725
	9909	Motor Nominal Power	2.4	2.4	2.4	2.4	2.4
START/STOP/DIR	1001	EXT1 Commands	(1) DI1	(1) DI1	(1) DI1	(1) DI1	(1) DI1
	1003	Direction	(1) Forward	(1) Forward	(1) Forward	(1) Forward	(1) Forward
REFERENCE SELECT	1103	REF1 Select	(1) AI1	(1) AI1	(1) AI1	(1) AI1	(1) AI1
	1104	REF1 Minimum	0 Hz	0 Hz	0 Hz	0 Hz	0 Hz
	1105	REF1 Maximum	60 Hz	60 Hz	60 Hz	60 Hz	60 Hz
CONSTANT SPEEDS	1201	Constant Speed Select	(8) DI2,3	(8) DI2,3	(8) DI2,3	(8) DI2,3	(8) DI2,3
	1202	Constant Speed 1	42.6	42.6	41.2	41.2	41.2
	1203	Constant Speed 2	60 Hz	60 Hz	60 Hz	60 Hz	60 Hz
	1204	Constant Speed 3	60 Hz	60 Hz	60 Hz	60 Hz	60 Hz
ANALOG INPUTS	1301	Minimum AI-1	20.00%	20.00%	20.00%	20.00%	20.00%
	1302	Maximum AI-1	100.00%	100.00%	100.00%	100.00%	100.00%
RELAY OUTPUTS	1401	Relay Output 1	(1) Ready	(1) Ready	(1) Ready	(1) Ready	(1) Ready
	1402	Relay Output 2	(2) Run	(2) Run	(2) Run	(2) Run	(2) Run
	1403	Relay Output 3	(16) FLT/ALARM	(16) FLT/ALARM	(16) FLT/ALARM	(16) FLT/ALARM	(16) FLT/ALARM
SYSTEM CONTROL	1604	Fault Reset Sel	(0) Keypad	(0) Keypad	(0) Keypad	(0) Keypad	(0) Keypad
	1608	Start Enable 1	(4) DI4	(4) DI4	(4) DI4	(4) DI4	(4) DI4
OVERRIDE	1701	Override Sel	(0) NOT SEL	(0) NOT SEL	(0) NOT SEL	(0) NOT SEL	(0) NOT SEL
LIMITS	2003	Maximum Current	9.1	4.6	10.6	5.3	4.8
	2007	Minimum Frequency	0.0 Hz	0.0 Hz	0.0 Hz	0.0 Hz	0.0 Hz
	2008	Maximum Frequency	60 Hz	60 Hz	60 Hz	60 Hz	60 Hz
START/STOP	2101	Start Function	(1) AUTO	(1) AUTO	(1) AUTO	(1) AUTO	(1) AUTO
	2102	Stop Function	(1) Coast	(1) Coast	(1) Coast	(1) Coast	(1) Coast
	2109	EM STOP Sel	(0) NOT SEL	(0) NOT SEL	(0) NOT SEL	(0) NOT SEL	(0) NOT SEL
ACCEL/DECEL	2201	Acc/Dec 1/2 Sel	(0) NOT SEL	(0) NOT SEL	(0) NOT SEL	(0) NOT SEL	(0) NOT SEL
	2202	Accelerate Time	30.0 s	30.0 s	30.0 s	30.0 s	30.0 s
	2203	Decelerate Time	10.0 s	10.0 s	10.0 s	10.0 s	10.0 s
MOTOR	2606	Switching Frequency	4 KHz	4 KHz	4 KHz	4 KHz	4 KHz
	2607	Switching Frequency Control	(1) ON	(1) ON	(1) ON	(1) ON	(1) ON
FAULT FUNCTIONS	3005	Motor Therm Prot	(1) Fault	(1) Fault	(1) Fault	(1) Fault	(1) Fault
	3006	Motor Thermal Time	1050 s	1050 s	1050 s	1050 s	1050 s
	3007	Motor Load Curve	100%	100%	100%	100%	100%
	3008	Zero Speed Load	%00705	%00705	%00705	%00705	%00705
	3009	Break Point Frequency	35 Hz	35 Hz	35 Hz	35 Hz	35 Hz
AUTOMATIC RESET	3104	AR Overcurrent	(0) DISABLE	(0) DISABLE	(0) DISABLE	(0) DISABLE	(0) DISABLE
	3105	AR Overvoltage	(1) ENABLE	(1) ENABLE	(1) ENABLE	(1) ENABLE	(1) ENABLE
	3106	AR Undervoltage	(1) ENABLE	(1) ENABLE	(1) ENABLE	(1) ENABLE	(1) ENABLE
EFB PROTOCOL	5301	EFB PROTOCOL ID	0601 (hex)	0601 (hex)	0601 (hex)	0601 (hex)	0601 (hex)
	5302	EFB STATION ID	41	41	41	41	41
	5303	EFB BAUD RATE	38400	38400	38400	38400	38400
	5304	EFB PARITY	8 NONE 1	8 NONE 1	8 NONE 1	8 NONE 1	8 NONE 1
	5305	EFB CTRL PROFILE	DCU PROFILE	DCU PROFILE	DCU PROFILE	DCU PROFILE	DCU PROFILE

## APPENDIX A — VFD OPERATION WITH REMOTE KEYPAD

### Table C — 50LC 05-06 VFD Parameters (cont)

		UNIT SIZE	50LC 06		50LC 05/06		
<b>PARAMETER GROUP</b>	<b>PARAMETER NUMBER</b>	<b>Motor Description</b>	2.4 HP 208-230-v	2.4 HP 460-v	2.9 HP 208-230-v	2.9 HP 460-v	3.7 HP 575-v
		<b>Drive/Motor Voltage</b>	208-230-v	460-v	208-230-v	460-v	575-v
		<b>Motor Part Number</b>	HD56FE653	HD56FE653	HD58FE654	HD58FE654	HD58FE577
		<b>VFD Part Number</b>	HK30WA001	HK30WA008	HK30WA001	HK30WA008	HK30WA021
		<b>ABB Part Number</b>	ACH550-CARUH-012A-2	ACH550-CARUH-06A9-4	ACH550-CARUH-012A-2	ACH550-CARUH-06A9-4	ACH550-CARUH-06A1-6
<b>OPTIONS</b>	<b>9802</b>	COMM PROT SEL	6 (LEN)	6 (LEN)	6 (LEN)	6 (LEN)	6 (LEN)

### VFD Diagnostics

The drive detects error situations and reports them using:

1. Green and red LEDs on the body of the drive (located under the keypad)
2. Status LED on the control panel
3. Control panel display
4. The Fault Word and Alarm Word parameter bits (parameters 0305 to 0309)

The form of the display depends on the severity of the error. The user can specify the severity for many errors by directing the drive to ignore the error situation, report the situation as an alarm, or report the situation as a fault.

#### FAULTS (RED LED LIT)

The VFD signals that it has detected a severe error, or fault, by:

1. Enabling the red LED on the drive (LED is either steady or flashing)
2. Setting an appropriate bit in a Fault Word parameter (0305 to 0307)
3. Overriding the control panel display with the display of a fault code
4. Stopping the motor (if it was on)
5. Sets an appropriate bit in Fault Word parameter 0305-0307.

The fault code on the control panel display is temporary. Pressing the MENU, ENTER, UP button or DOWN buttons removes the fault message. The message reappears after a few seconds if the control panel is not touched and the fault is still active.

#### ALARMS (GREEN LED FLASHING)

For less severe errors, called alarms, the diagnostic display is advisory. For these situations, the drive is simply reporting that it had detected something unusual.

In these situations, the drive:

1. Flashes the green LED on the drive (does not apply to alarms that arise from control panel operation errors)
2. Sets an appropriate bit in an Alarm Word parameter (0308 or 0309)
3. Overrides the control panel display with the display of an alarm code and/or name

Alarm messages disappear from the control panel display after a few seconds. The message returns periodically as long as the alarm condition exists.

#### CORRECTING FAULTS

The recommended corrective action for faults is shown in the Fault Codes Table D. The VFD can also be reset to remove the fault. If an external source for a start command is selected and is active, the VFD may start immediately after fault reset.

To reset a fault indicated by a flashing red LED, turn off the power for 5 minutes. To reset a fault indicated by a red LED (not flashing), press RESET from the control panel or turn off the power for 5 minutes. Depending on the value of parameter 1604 (FAULT

RESET SELECT), digital input or serial communication could also be used to reset the drive. When the fault has been corrected, the motor can be started.

#### HISTORY

For reference, the last three fault codes are stored into parameters 0401, 0412, 0413. For the most recent fault (identified by parameter 0401), the drive stores additional data (in parameters 0402 through 0411) to aid in troubleshooting a problem. For example, a parameter 0404 stores the motor speed at the time of the fault. To clear the fault history (all of Group 04, Fault History parameters), follow these steps:

1. In the control panel, Parameters mode, select parameter 0401.
2. Press EDIT.
3. Press the UP and DOWN buttons simultaneously.
4. Press SAVE.

#### CORRECTING ALARMS

To correct alarms, first determine if the Alarm requires any corrective action (action is not always required). Use Table E to find and address the root cause of the problem.

If diagnostics troubleshooting has determined that the drive is defective during the warranty period, contact ABB Automation Inc., at 1-800-435-7365, option 4, option 3. A qualified technician will review the problem with the caller and make a determination regarding how to proceed. This may involve dispatching a designated service station (DSS) representative from an authorized station, dispatching a replacement unit, or advising return for repair.

#### CONTROL PANEL CLEANING

Use a soft damp cloth to clean the control panel. Avoid harsh cleaners which could scratch the display window.

#### BATTERY REPLACEMENT

A battery is only used in assistant control panels that have the clock function available and enabled. The battery keeps the clock operating in memory during power interruptions. The expected life for the battery is greater than ten years. To remove the battery, use a coin to rotate the battery holder on the back of the control panel. Replace the battery with type CR2032.



## APPENDIX A — VFD OPERATION WITH REMOTE KEYPAD

### Table D — FAULT CODES

FAULT CODE	FAULT NAME IN PANEL	DESCRIPTION AND RECOMMENDED CORRECTIVE ACTION
1	OVERCURRENT	Output current is excessive. Check for excessive motor load, insufficient acceleration time (parameters 2202 ACCELER TIME 1, default 30 seconds), or faulty motor, motor cables or connections.
2	DC OVERVOLT	Intermediate circuit DC voltage is excessive. Check for static or transient over voltages in the input power supply, insufficient deceleration time (parameters 2203 DECELER TIME 1, default 30 seconds), or undersized brake chopper (if present).
3	DEV OVERTEMP	Drive heat sink is overheated. Temperature is at or above 115°C (239°F). Check for fan failure, obstructions in the airflow, dirt or dust coating on the heat sink, excessive ambient temperature, or excessive motor load.
4	SHORT CIRC	Fault current. Check for short-circuit in the motor cable(s) or motor or supply disturbances.
5	OVERLOAD	Inverter overload condition. The drive output current exceeds the ratings.
6	DC OVERVOLT	Intermediate circuit DC voltage is not sufficient. Check for missing phase in the input power supply, blown fuse, or under voltage on main circuit.
7	AI1 LOSS	Analog input 1 loss. Analog input value is less than AI1 FLT LIMIT (3021). Check source and connection for analog input and parameter settings for AI1 FLT LIMIT (3021) and 3001 AI<MIN FUNCTION.
8	AI2 LOSS	Analog input 2 loss. Analog input value is less than AI2 FLT LIMIT (3022). Check source and connection for analog input and parameter settings for AI2 FLT LIMIT (3022) and 3001 AI<MIN FUNCTION.
9	MOT OVERTEMP	Motor is too hot, as estimated by the drive. Check for overloaded motor. Adjust the parameters used for the estimate (3005 through 3009). Check the temperature sensors and Group 35 parameters.
10	PANEL LOSS	Panel communication is lost and either drive is in local control mode (the control panel displays LOC), or drive is in remote control mode (REM) and is parameterized to accept start/stop, direction or reference from the control panel. To correct check the communication lines and connections. Check parameter 3002 PANEL COMM ERROR, parameters in Group 10: Command Inputs and Group 11:Reference Select (if drive operation is REM).
11	ID RUN FAIL	The motor ID run was not completed successfully. Check motor connections.
12	MOTOR STALL	Motor or process stall. Motor is operating in the stall region. Check for excessive load or insufficient motor power. Check parameters 3010 through 3012.
13	RESERVED	Not used.
14	EXT FAULT 1	Digital input defined to report first external fault is active. See parameter 3003 EXTERNAL FAULT 1.
15	EXT FAULT 2	Digital input defined to report second external fault is active. See parameter 3004 EXTERNAL FAULT 2.
16	EARTH FAULT	The load on the input power system is out of balance. Check for faults in the motor or motor cable. Verify that motor cable does not exceed maximum specified length.
17	UNDERLOAD	Motor load is lower than expected. Check for disconnected load. Check parameters 3013 UNDERLOAD FUNCTION through 3015 UNDERLOAD CURVE.
18	THERM FAIL	Internal fault. The thermistor measuring the internal temperature of the drive is open or shorted. Contact Carrier.
19	OPEX LINK	Internal fault. A communication-related problem has been detected between the OMIO and OINT boards. Contact Carrier.
20	OPEX PWR	Internal fault. Low voltage condition detected on the OINT board. Contact Carrier.
21	CURR MEAS	Internal fault. Current measurement is out of range. Contact Carrier.
22	SUPPLY PHASE	Ripple voltage in the DC link is too high. Check for missing main phase or blown fuse.
23	RESERVED	Not used.
24	OVERSPEED	Motor speed is greater than 120% of the larger (in magnitude) of 2001 MINIMUM SPEED or 2002 MAXIMUM SPEED parameters. Check parameter settings for 2001 and 2002. Check adequacy of motor braking torque. Check applicability of torque control. Check brake chopper and resistor.
25	RESERVED	Not used.
26	DRIVE ID	Internal fault. Configuration block drive ID is not valid.
27	CONFIG FILE	Internal configuration file has an error. Contact Carrier.
28	SERIAL 1 ERR	Field bus communication has timed out. Check fault setup (3018 COMM FAULT FUNC and 3019 COMM FAULT TIME). Check communication settings (Group 51 or 53 as appropriate). Check for poor connections and/or noise on line.
29	EFB CON FILE	Error in reading the configuration file for the field bus adapter.
30	FORCE TRIP	Fault trip forced by the field bus. See the field bus reference literature.
31	EFB 1	Fault code reserved for the EFB protocol application. The meaning is protocol dependent.
32	EFB 2	Fault code reserved for the EFB protocol application. The meaning is protocol dependent.
33	EFB 3	Fault code reserved for the EFB protocol application. The meaning is protocol dependent.
34	MOTOR PHASE	Fault in the motor circuit. One of the motor phases is lost. Check for motor fault, motor cable fault, thermal relay fault, or internal fault.
35	OUTP WIRING	Error in power wiring suspected. Check that input power is wired to drive output. Check for ground faults.
101-105	SYSTEM ERROR	Error internal to the drive. Contact Carrier and report the error number.
201-206	SYSTEM ERROR	Error internal to the drive. Contact Carrier and report the error number.
1000	PAR HZRPM	Parameter values are inconsistent. Check for any of the following: 2001 MINIMUM SPEED > 2002 MAXIMUM SPEED 2007 MINIMUM FREQ > 2008 MAXIMUM FREQ 2001 MINIMUM SPEED / 9908 MOTOR NOM SPEED is outside of the range: ---128/+128 2002 MAXIMUM SPEED / 9908 MOTOR NOM SPEED is outside of the range: ---128/+128 2007 MINIMUM FREQ / 9907 MOTOR NOM FREQ is outside of the range: --- 128/+128 2008 MAXIMUM FREQ / 9907 MOTOR NOM FREQ is outside of the range: --- 128/+128

## APPENDIX A — VFD OPERATION WITH REMOTE KEYPAD

### Table D — FAULT CODES (cont)

FAULT CODE	FAULT NAME IN PANEL	DESCRIPTION AND RECOMMENDED CORRECTIVE ACTION
1001	PAR PFA REFNG	Parameter values are inconsistent. Check that 2007 MINIMUM FREQ is negative, when 8123 PFA ENABLE is active.
1002	PAR PFA IOCNF	Parameter values are inconsistent. The number of programmed PFA relays does not match with Interlock configuration, when 8123 PFA ENABLE is active. Check consistency of RELAY OUTPUT parameters 1401 through 1403, and 1410 through 1412. Check 8117 NR OF AUX MOTORS, 8118 AUTOCHANGE INTERV, and 8120 INTERLOCKS.
1003	PAR AI SCALE	Parameter values are inconsistent. Check that parameter 1301 AI 1 MIN > 1302 AI 1 MAX and that parameter 1304 AI 2 MIN > 1305 AI 2 MAX.
1004	PAR AO SCALE	Parameter values are inconsistent. Check that parameter 1504 AO 1 MIN > 1505 AO 1 MAX and that parameter 1510 AO 2 MIN > 1511 AO 2 MAX.
1005	PAR PCU 2	Parameter values for power control are inconsistent: Improper motor nominal kVA or motor nominal power. Check the following parameters: $1.1 < (9906 \text{ MOTOR NOM CURR} * 9905 \text{ MOTOR NOM VOLT} * 1.73 / \text{PN}) < 2.6$ Where: PN = 1000 * 9909 MOTOR NOM POWER (if units are kW) or PN = 746 * 9909 MOTOR NOM POWER (if units are HP, e.g., in US)
1006	PAR EXT RO	Parameter values are inconsistent. Check the extension relay module for connection and 1410 through 1412 RELAY OUTPUTS 4 through 6 have non-zero values.
1007	PAR FBUS	Parameter values are inconsistent. Check that a parameter is set for field bus control (e.g., 1001 EXT1 COMMANDS = 10 (COMM)), but 9802 COMM PROT SEL = 0.
1008	PAR PFA MODE	Parameter values are inconsistent. The 9904 MOTOR CTRL MODE must = 3 (SCALAR SPEED) when 8123 PFA ENABLE activated.
1009	PAR PCU 1	Parameter values for power control are inconsistent or improper motor nominal frequency or speed. Check for both of the following: $1 < (60 * 9907 \text{ MOTOR NOM FREQ} / 9908 \text{ MOTOR NOM SPEED}) < 16$ $0.8 < 9908 \text{ MOTOR NOM SPEED} / (120 * 9907 \text{ MOTOR NOM FREQ} / \text{Motor poles}) < 0.992$
1010	OVERRIDE/PFA CONFLICT	Override mode is enabled and PFA is activated at the same time. This cannot be done because PFA interlocks cannot be observed in the override mode.



## APPENDIX A — VFD OPERATION WITH REMOTE KEYPAD

### Table E — ALARM CODES

ALARM CODE	ALARM NAME IN PANEL	DESCRIPTION AND RECOMMENDED CORRECTIVE ACTION
2001	-	Reserved
2002	-	Reserved
2003	-	Reserved
2004	DIR LOCK	The change in direction being attempted is not allowed. Do not attempt to change the direction of motor rotation, or change parameter 1003 DIRECTION to allow direction change (if reverse operation is safe).
2005	I/O COMM	Field bus communication has timed out. Check fault setup (3018 COMM FAULT FUNC and 3019 COMM FAULT TIME). Check communication settings (Group 51 or 53 as appropriate). Check for poor connections and/or noise on line.
2006	AI1 LOSS	Analog input 1 is lost, or value is less than the minimum setting. Check input source and connections. Check the parameter that sets the minimum (3021) and the parameter that sets the Alarm/Fault operation (3001).
2007	AI2 LOSS	Analog input 2 is lost, or value is less than the minimum setting. Check input source and connections. Check parameter that sets the minimum (3022) and the parameter that sets the Alarm/Fault operation (3001).
2008	PANEL LOSS	Panel communication is lost and either the VFD is in local control mode (the control panel displays HAND), or the VFD is in remote control mode (AUTO) and is parameterized to accept start/stop, direction or reference from the control panel. To correct, check the communication lines and connections, Parameter 3002 PANEL LOSS, and parameters in groups 10 COMMAND INPUTS and 11 REFERENCE SELECT (if drive operation is REM).
2009	-	Reserved
2010	MOT OVERTEMP	Motor is hot, based on either the VFD estimate or on temperature feedback. This alarm warns that a Motor Overload fault trip may be near. Check for overloaded motor. Adjust the parameters used for the estimate (3005 through 3009). Check the temperature sensors and Group 35 parameters.
2011	UNDERLOAD	Motor load is lower than expected. This alarm warns that a Motor Underload fault trip may be near. Check that the motor and drive ratings match (motor is NOT undersized for the drive). Check the settings on parameters 3013 to 3015.
2012	MOTOR STALL	Motor is operating in the stall region. This alarm warns that a Motor Stall fault trip may be near.
2013*	AUTORESET	This alarm warns that the drive is about to perform an automatic fault reset, which may start the motor. To control automatic reset, use parameter group 31 (AUTOMATIC RESET).
2014	AUTOCHANGE	This alarm warns that the PFA autochange function is active. To control PFA, use parameter group 81 (PFA) and the Pump Alternation macro.
2015	PFA INTERLOCK	This alarm warns that the PFA interlocks are active, which means that the drive cannot start any motor (when Autochange is used), or a speed regulated motor (when Autochange is not used).
2016	-	Reserved
2017*	OFF BUTTON	This alarm indicates that the OFF button has been pressed.
2018	PID SLEEP	This alarm warns that the PID sleep function is active, which means that the motor could accelerate when the PID sleep function ends. To control PID sleep, use parameters 4022 through 4026 or 4122 through 4126.
2019	ID RUN	The VFD is performing an ID run.
2020	OVERRIDE	Override mode is activated.
2021	START ENABLE 1 MISSING	This alarm warns that the Start Enable 1 signal is missing. To control Start Enable 1 function, use parameter 1608. To correct, check the digital input configuration and the communication settings.
2022	START ENABLE 2 MISSING	This alarm warns that the Start Enable 2 signal is missing. To control Start Enable 2 function, use parameter 1609. To correct, check the digital input configuration and the communication settings.
2023	EMERGENCY STOP	Emergency stop is activated.

\* This alarm is not indicated by a relay output, even when the relay output is configured to indicate alarm conditions, parameter 1401 RELAY OUTPUT = 5 (ALARM) or 16 (FLT/ALARM).







# START-UP CHECKLIST FOR 50LC SINGLE PACKAGE ROOFTOP COOLING ONLY

(Remove and Store in Job File)

**NOTE: To avoid injury to personnel and damage to equipment or property when completing the procedures listed in this start-up checklist, use good judgment, follow safe practices, and adhere to the safety considerations/information as outlined in preceding sections of this Installation Instruction document.**

## I. PRELIMINARY INFORMATION

MODEL NO \_\_\_\_\_

JOB NAME \_\_\_\_\_

SERIAL NO \_\_\_\_\_

ADDRESS \_\_\_\_\_

START-UP DATE \_\_\_\_\_

TECHNICIAN NAME \_\_\_\_\_

ADDITIONAL ACCESSORIES \_\_\_\_\_

## II. PRE-START-UP

Verify that all packaging materials have been removed from unit (Y/N) \_\_\_\_\_

Verify installation of outdoor air hood (Y/N) \_\_\_\_\_

Verify that condensate connection is installed per instructions (Y/N) \_\_\_\_\_

Verify that all electrical connections and terminals are tight (Y/N) \_\_\_\_\_

Check that indoor-air filters are clean and in place (Y/N) \_\_\_\_\_

Check that outdoor-air inlet screens are in place (Y/N) \_\_\_\_\_

Verify that unit is level (Y/N) \_\_\_\_\_

Check fan wheels and propeller for location in housing/orifice and verify setscrew is tight (Y/N) \_\_\_\_\_

Verify that fan sheaves are aligned and belts are properly tensioned (Y/N) \_\_\_\_\_

Verify that scroll compressors are rotating in the correct direction (Y/N) \_\_\_\_\_

Verify installation of thermostat (Y/N) \_\_\_\_\_

## III. START-UP

### ELECTRICAL

Supply Voltage L1-L2 \_\_\_\_\_ L2-L3 \_\_\_\_\_ L3-L1 \_\_\_\_\_

Compressor Amps 1 L1 \_\_\_\_\_ L2 \_\_\_\_\_ L3 \_\_\_\_\_

Compressor Amps 2 L1 \_\_\_\_\_ L2 \_\_\_\_\_ L3 \_\_\_\_\_

Supply Fan Amps L1 \_\_\_\_\_ L2 \_\_\_\_\_ L3 \_\_\_\_\_

### TEMPERATURES

Outdoor-air Temperature \_\_\_\_\_ °F DB (Dry Bulb)

Return-air Temperature \_\_\_\_\_ °F DB \_\_\_\_\_ °F Wb (Wet Bulb)

Cooling Supply Air Temperature \_\_\_\_\_ °F

### PRESSURES

Refrigerant Suction CIRCUIT A \_\_\_\_\_ PSIG

CIRCUIT B \_\_\_\_\_ PSIG

Refrigerant Discharge CIRCUIT A \_\_\_\_\_ PSIG

CIRCUIT B \_\_\_\_\_ PSIG

Verify Refrigerant Charge using Charging Charts (Y/N) \_\_\_\_\_

**GENERAL**

Economizer minimum vent and changeover settings to job requirements (if equipped) (Y/N) \_\_\_\_\_

Verify smoke detector unit shutdown by utilizing magnet test (Y/N) \_\_\_\_\_

**IV. HUMIDI-MIZER® START-UP**

NOTE: Units equipped with either SystemVu™ or RTU Open controls have Service Test menus or modes that can assist with the Humidi-MiZer System Start-Up function and provide the means to make the observations listed for this start-up.

**STEPS**

- 1. Check CTB for jumper 5, 6, 7 (Jumper 5, 6, 7 must be cut and open) (Y/N) \_\_\_\_\_
- 2. Open humidistat contacts (Y/N) \_\_\_\_\_
- 3. Start unit In cooling (Close Y1) (Y/N) \_\_\_\_\_

**OBSERVE AND RECORD**

- A. Suction pressure \_\_\_\_\_ PSIG
  - B. Discharge pressure \_\_\_\_\_ PSIG
  - C. Entering air temperature \_\_\_\_\_ ° F
  - D. Liquid line temperature at outlet or reheat coil \_\_\_\_\_ ° F
  - E. Confirm correct rotation for compressor (Y/N) \_\_\_\_\_
  - F. Check for correct ramp-up of outdoor fan motor as condenser coil warms (Y/N) \_\_\_\_\_
4. Check unit charge per charging chart (Y/N) \_\_\_\_\_  
(Jumper 32L Motormaster® temperature sensor during this check. Remove jumper when complete.)
5. Switch unit to high-latent mode (sub-cooler) by closing humidistat with Y1 closed (Y/N) \_\_\_\_\_

**OBSERVE**

- A. Reduction in suction pressure (5 to 7 psi expected) (Y/N) \_\_\_\_\_
  - B. Discharge pressure unchanged (Y/N) \_\_\_\_\_
  - C. Liquid temperature drops to 50°F to 55°F range (Y/N) \_\_\_\_\_
  - D. LSV solenoid energized (valve closes) (Y/N) \_\_\_\_\_
6. Switch unit to dehumid (reheat) by opening Y1 (Y/N) \_\_\_\_\_

**OBSERVE**

- A. Suction pressure increases to normal cooling level
  - B. Discharge pressure decreases (35 to 50 psi) (Limited by Motormaster control)
  - C. Liquid temperature returns to normal cooling level
  - D. LSV solenoid energized (valve closes)
  - E. DSV solenoid energized, valve opens
7. With unit in dehumid mode close W1 compressor and outdoor fan stop; LSV and DSV solenoids de-energized (Y/N) \_\_\_\_\_
8. Open W1 restore unit to dehumid mode (Y/N) \_\_\_\_\_
9. Open humidistat input compressor and outdoor fan stop; LSV and DSV solenoids de-energized (Y/N) \_\_\_\_\_
10. Restore set-points for thermostat and humidistat (Y/N) \_\_\_\_\_

**REPEAT PROCESS FOR 2 COMPRESSOR SYSTEMS.**

CUT ALONG DOTTED LINE