



Installation, Start-Up and Service Instructions

TABLE OF CONTENTS

SAFETY CONSIDERATIONS	1	Coil Removal	22
PRE-INSTALLATION	2	Cleaning Cooling Coil	22
Moving and Storage	2	Cleaning Insulation	22
Rigging	2	Replacing Filters	22
INSTALLATION	2-18	START-UP CHECKLIST	35-36
General	2		
Uncrating	2		
Accessories	2		
Unit Positioning	9		
Unit Isolation	11		
Refrigerant Piping Access	11		
Refrigerant Piping	11		
Condensate Drain	14		
Fan Motors and Drives	15		
Power Supply and Wiring	15		
Connecting Ductwork	17		
Return-Air Filters	17		
START-UP	19		
SERVICE	19-32		
Panels	19		
Fan Motor Lubrication	20		
Fan Shaft Bearings	20		
Centering Fan Wheel	20		
Fan Shaft Position Adjustment	20		
Individual Fan Wheel Adjustment	21		
Fan Belts	21		
Fan Rotation	21		
Fan Pulley Alignment	21		
Pulley and Drive Adjustment	21		
Condensate Drains	21		
Return-Air Filters	21		

SAFETY CONSIDERATIONS

Improper installation, adjustment, alteration, service, maintenance, or use can cause explosion, fire, electrical shock or other conditions which may cause personal injury or property damage. Consult a qualified installer, service agency, or your distributor or branch for information or assistance. The qualified installer or agency must use factory-authorized kits or accessories when modifying this product. Refer to the individual instructions package

Follow all safety codes. Wear safety glasses and work gloves. Use quenching cloths for brazing operations and have a fire extinguisher available. Read these instructions thoroughly and follow all warnings or cautions attached to the unit. Consult local building codes and appropriate national electrical codes (in USA, ANSI/NFPA70, National Electrical Code (NEC); in Canada, CSA C22.1) for special requirements.

It is important to recognize safety information. This is the safety-alert symbol . When you see this symbol on the unit and in instructions or manuals, be alert to the potential for personal injury.

Understand the signal words DANGER, WARNING, CAUTION, and NOTE. These words are used with the safety-alert symbol. DANGER identifies the most serious hazards which **will** result in severe personal injury or death. WARNING signifies hazards which **could** result in personal injury or death. CAUTION is used to identify unsafe practices, which **may** result in minor personal injury or product and property damage. NOTE is used to highlight suggestions which **will** result in enhanced installation, reliability, or operation.

⚠ WARNING**ELECTRICAL SHOCK HAZARD**

Failure to follow this warning could cause in personal injury or death.

Before performing service or maintenance operations on unit, always turn off main power switch to unit and install lockout tag. Unit may have more than one power switch.

⚠ WARNING**UNIT OPERATION AND SAFETY HAZARD**

Failure to follow this warning could cause in personal injury, death and/or equipment damage.

Puron® (R-410A) refrigerant systems operate at higher pressures than standard R-22 systems. Do not use R-22 service equipment or components on Puron refrigerant equipment.

⚠ WARNING**PERSONAL INJURY AND ENVIRONMENTAL HAZARD**

Failure to follow this warning could cause in personal injury or death.

Relieve pressure and recover all refrigerant before system repair or final unit disposal.

Wear safety glasses and gloves when handling refrigerants. Keep torches and other ignition sources away from refrigerants and oils.

⚠ CAUTION**CUT HAZARD**

Failure to follow this caution may result in personal injury.

Sheet metal parts may have sharp edges or burrs. Use care and wear appropriate protective clothing, safety glasses and gloves when handling parts and servicing 524J units.

⚠ CAUTION**UNIT OPERATION HAZARD**

Failure to follow this caution could cause equipment damage.

Ensure voltage listed on unit data plate agrees with electrical supply provided for the unit.

PRE-INSTALLATION

1. The power supply (v, ph, and Hz) must correspond to that specified on unit rating plate.
2. The electrical supply provided by the utility must be sufficient to handle load imposed by this unit.
3. Refer to Installation, General section (page 2) and Fig. 1 and Fig. 2 for locations of electrical inlets, condensate drain, duct connections, and required clearances before setting unit in place.
4. This installation must conform with local building codes and with the NEC (National Electrical Code) or ANSI (American National Standards Institute)/NFPA (National Fire Protection Association) latest revision. Refer to provincial and local plumbing or wastewater codes and other applicable local codes.

Moving and Storage - To transfer unit from truck to storage site, use a fork truck. Do not stack units more than 2 high during storage. If unit is to be stored for more than 2 weeks before installation, choose a level, dry storage site free from vibration. Do not remove plastic wrap or skid from unit until final installation.

Rigging - All 524J Series units can be rigged by using the shipping skid. Units are shipped fully assembled. Do not remove shipping skids or protective covering until unit is ready for final placement; damage to bottom panels can result. Use slings and spreader bars as applicable to lift unit.

INSTALLATION

General - Allow the following clearances for service access and airflow:

- Rear: 3 ft (914 mm) [2¹/₂ ft (762 mm) with electric heat accessory]
- Front: 2¹/₂ ft (762 mm)
- Right Side: 3¹/₂ ft (1067 mm)
- Left Side: 2¹/₂ ft (762 mm)

For units equipped with an economizer, refer to the accessory installation instructions for additional clearance requirements. Be sure floor, wall, or ceiling can support unit weight (Tables 1A – 1D). See Fig. 1 and Fig. 2 for dimensions.

Uncrating - Move unit as near as possible to final location before removing shipping skid.

Remove metal banding, top skid, and plastic wrap. Examine unit for shipping damage. If shipping damage is evident, file claim with transportation agency. Remove base skid just prior to actual installation.

Check nameplate information against available power supply and model number description in Fig. 3.

NOTE: Be sure to remove the styrofoam shipping pad from the thermostatic expansion valve (TXV). Verify that it has been removed. See Fig. 5.

Accessories - Refer to instructions shipped with each accessory for specific information.

Table 1A — 524J***A Physical Data, English — Cooling Units

UNIT 524J*	25A	28A	30A
NOMINAL CAPACITY (Tons)	20	25	30
OPERATING WEIGHT (lb)			
Base Unit with TXV	730	1050	1062
Plenum	225	325	325
FANS			
Qty...Diam. (in.)	2...15	2...18	2...18
Nominal Airflow (cfm)	8000	10000	12000
Airflow Range (cfm)	6000 – 10000	7500 – 12500	9000 – 15000
Nominal Motor Hp (Standard Motor)			
208/230–3–60 and 460–3–60	5.0	7.5	10.0
575–3–60	5.0	7.5	10.0
Motor Speed (rpm)			
208/230–3–60 and 460–3–60	1745	1745	1745
575–3–60	1745	1755	1755
REFRIGERANT	R-410A		
Operating charge (lb) (approx per circuit)*	3.5	4.5	5.0
DIRECT-EXPANSION COIL	Enhanced Copper Tubes, Aluminum Sine-Wave Fins		
Max Working Pressure (psig)		650	
Face Area (sq ft)	19.88	24.86	29.83
No. of Splits	2	2	2
No. of Circuits per Split	18	20	24
Split Type...Percentage		Face...50/50	
Rows...Fins/in.	4...15	4...15	4...15
PIPING CONNECTIONS, Quantity...Size (in.)			
DX Coil — Suction (ODF)	2...1 ¹ / ₈	2...1 ³ / ₈	2...1 ³ / ₈
DX Coil — Liquid Refrigerant (ODF)		2... ⁵ / ₈	
Steam Coil, In (MPT)		1...2 ¹ / ₂	
Steam Coil, Out (MPT)		1... ¹ / ₂	
Hot Water Coil, In (MPT)		1...2	
Hot Water Coil, Out (MPT)		1...2	
Condensate (PVC)		1...1 ¹ / ₄ ODM/1 IDF	
FILTERS	Throwaway — Factory Supplied		
Quantity...Size (in.)	4...16 x 20 x 2 4...16 x 24 x 2	4...20 x 24 x 2 4...20 x 25 x 2	
Access Location	Either Side		
STEAM COIL**			
Max Working Pressure (psig at 260° F)		20	
Total Face Area (sq ft)	13.33	15.0	15.0
Rows...Fins/in.	1...10	1...10	1...10
HOT WATER COIL**			
Max Working Pressure (psig)		150	
Total Face Area (sq ft)	13.33	15.0	15.0
Rows...Fins/in.	2...8.5	2...12.5	2...12.5
Water Volume			
(gal)	13.9		14.3
(ft ³)			1.90

LEGEND

- DX — Direct Expansion
- TXV — Thermostatic Expansion Valve
- * Units are shipped without refrigerant charge.
- ** Field installed accessory only.

524J

Table 1B —524J***A Physical Data, SI — Cooling Units

UNIT 524J*	25A	28A	30A
NOMINAL CAPACITY (kW)	70	87	105
OPERATING WEIGHT (kg)			
Base Unit with TXV	331	477	482
Plenum	102	148	148
FANS			
Qty...Diam. (mm)	2...381	2...457	2...457
Nominal Airflow (L/s)	3775	4119	5663
Airflow Range (L/s)	2831 – 4719	3539 – 5899	4247 – 7079
Nominal Motor kW (Standard Motor)			
208/230–3–60 and 460–3–60	3.73	5.60	7.46
575–3–60	3.73	5.60	7.46
Motor Speed (r/s)			
208/230–3–60 and 460–3–60	29.1	29.1	29.1
575–3–60	29.1	29.3	29.3
REFRIGERANT	R-410A		
Operating charge (kg) (approx per circuit)*	1.59	2.04	2.27
DIRECT-EXPANSION COIL	Enhanced Copper Tubes, Aluminum Sine-Wave Fins		
Max Working Pressure (kPag)		4481	
Face Area (sq m)	1.85	2.30	2.77
No. of Splits	2	2	2
No. of Circuits per Split	18	20	24
Split Type...Percentage		Face...50/50	
Rows...Fins/m	4...591	4...591	4...591
PIPING CONNECTIONS, Quantity...Size (in.)			
DX Coil — Suction (ODF)	2...1 ¹ / ₈	2...1 ³ / ₈	2...1 ³ / ₈
DX Coil — Liquid Refrigerant (ODF)		2... ⁵ / ₈	
Steam Coil, In (MPT)		1...2 ¹ / ₂	
Steam Coil, Out (MPT)		1... ¹ / ₂	
Hot Water Coil, In (MPT)		1...2	
Hot Water Coil, Out (MPT)		1...2	
Condensate (PVC)		1...1 ¹ / ₄ ODM/1 IDF	
FILTERS	Throwaway — Factory Supplied		
Quantity...Size (mm.)	4...406 x 508 x 51 4...406 x 610 x 51	4...508 x 610 x 51 4...508 x 635 x 51	
Access Location	Either Side		
STEAM COIL**			
Max Working Pressure (kPag at 126° C)		138	
Total Face Area (sq m)	1.24	1.39	1.39
Rows...Fins/m	1...394	1...394	1...394
HOT WATER COIL**			
Max Working Pressure (kPag)		1034	
Total Face Area (sq m)	1.24	1.39	1.39
Rows...Fins/m	2...335	2...335	2...335
Water Volume			
(L)	52.6		54.1
(m ³)	0.052		0.054

LEGEND

- DX — Direct Expansion
- TXV — Thermostatic Expansion Valve
- * Units are shipped without refrigerant charge.
- ** Field installed accessory only.

Table 1C — 524J*25H Physical Data, English — Heat Pump Units

UNIT 524J*	25H
NOMINAL CAPACITY (Tons)	20
OPERATING WEIGHT (lb)	
Base Unit with TXV	720
Plenum	140
FANS	
Qty...Diam. (in.)	2...15
Nominal Airflow (cfm)	8000
Airflow Range (cfm)	6000–10000
Nominal Motor Hp (Standard Motor)	
208/230–3–60 and 460–3–60	5.0
575–3–60	5.0
Motor Speed (rpm)	
208/230–3–60 and 460–3–60	1745
575–3–60	1745
REFRIGERANT	R–410A
Operating charge (lb) (approx per circuit)*	3.5/3.5
DIRECT–EXPANSION COIL	Enhanced Copper Tubes, Aluminum Sine–Wave Fins
Max Working Pressure (psig)	650
Face Area (sq ft)	19.9
No. of Splits	2
No. of Circuits per Split	2
Split Type...Percentage	Face....50/50
Rows...Fins/in.	4...15
PIPING CONNECTIONS,	
Quantity...Size (in.)	
DX Coil — Suction (ODF)	2...1 ¹ / ₈
DX Coil — Liquid Refrigerant (ODF)	2... ⁵ / ₈
Steam Coil, In (MPT)	1...2 ¹ / ₂
Steam Coil, Out (MPT)	1...1 ¹ / ₂
Hot Water Coil, In (MPT)	1...2
Hot Water Coil, Out (MPT)	1...2
Condensate (PVC)	1...1 ¹ / ₄ ODM/1 IDF
FILTERS	Throwaway — Factory Supplied
Quantity...Size (in.)	4...16 x 20 x 2 4...16 x 24 x 2
Access Location	Right or Left Side
STEAM COIL**	
Max Working Pressure (psig at 260° F)	20
Total Face Area (sq ft)	13.33
Rows...Fins/in.	1...10
HOT WATER COIL**	
Max Working Pressure (psig)	150
Total Face Area (sq ft)	13.33
Rows...Fins/in.	2...8.5
Water Volume	
(gal)	13.9
(ft ³)	1.85

LEGEND

DX — Direct Expansion

TXV — Thermostatic Expansion Valve

* Units are shipped without refrigerant charge.

** Field installed accessory only.

Table 1D — 524J*25H Physical Data, SI — Heat Pump Units

UNIT 524J*	25H
NOMINAL CAPACITY (kW)	70
OPERATING WEIGHT (kg)	
Base Unit with TXV	326
Plenum	44
FANS	
Qty...Diam. (mm)	2...381
Nominal Airflow (L/s)	3775
Airflow Range (L/s)	2831–4719
Nominal Motor kW (Standard Motor)	
208/230–3–60 and 460–3–60	3.73
575–3–60	3.73
Motor Speed (r/s)	
208/230–3–60 and 460–3–60	29.1
575–3–60	29.1
REFRIGERANT	R–410A
Operating charge (kg) (approx per circuit)*	1.59/1.59
DIRECT–EXPANSION COIL	Enhanced Copper Tubes, Aluminum Sine–Wave Fins
Max Working Pressure (kPag)	4482
Face Area (sq m)	1.85
No. of Splits	2
No. of Circuits per Split	2
Split Type...Percentage	Face...50/50
Fins/m	591
PIPING CONNECTIONS,	
Quantity...Size (in.)	
DX Coil — Suction (ODF)	2...1 ¹ / ₈
DX Coil — Liquid Refrigerant (ODF)	2... ⁵ / ₈
Steam Coil, In (MPT)	1...2 ¹ / ₂
Steam Coil, Out (MPT)	1...1 ¹ / ₂
Hot Water Coil, In (MPT)	1...2
Hot Water Coil, Out (MPT)	1...2
Condensate (PVC)	1...1 ¹ / ₄ ODM/1 IDF
FILTERS	Throwaway — Factory Supplied
Quantity...Size (mm)	4...406 x 610 x 51 4...406 x 508 x 51
Access Location	Right or Left Side
STEAM COIL**	
Max Working Pressure (kPag at 126° C)	138
Total Face Area (sq m)	1.24
Rows...Fins/m	1...394
HOT WATER COIL**	
Max Working Pressure (kPag)	1034
Total Face Area (sq m)	1.24
Rows...Fins/m	2...335
Water Volume	
(L)	52.6
(m ³)	0.052

LEGEND

DX — Direct Expansion

TXV — Thermostatic Expansion Valve

* Units are shipped without refrigerant charge.

** Field installed accessory only.

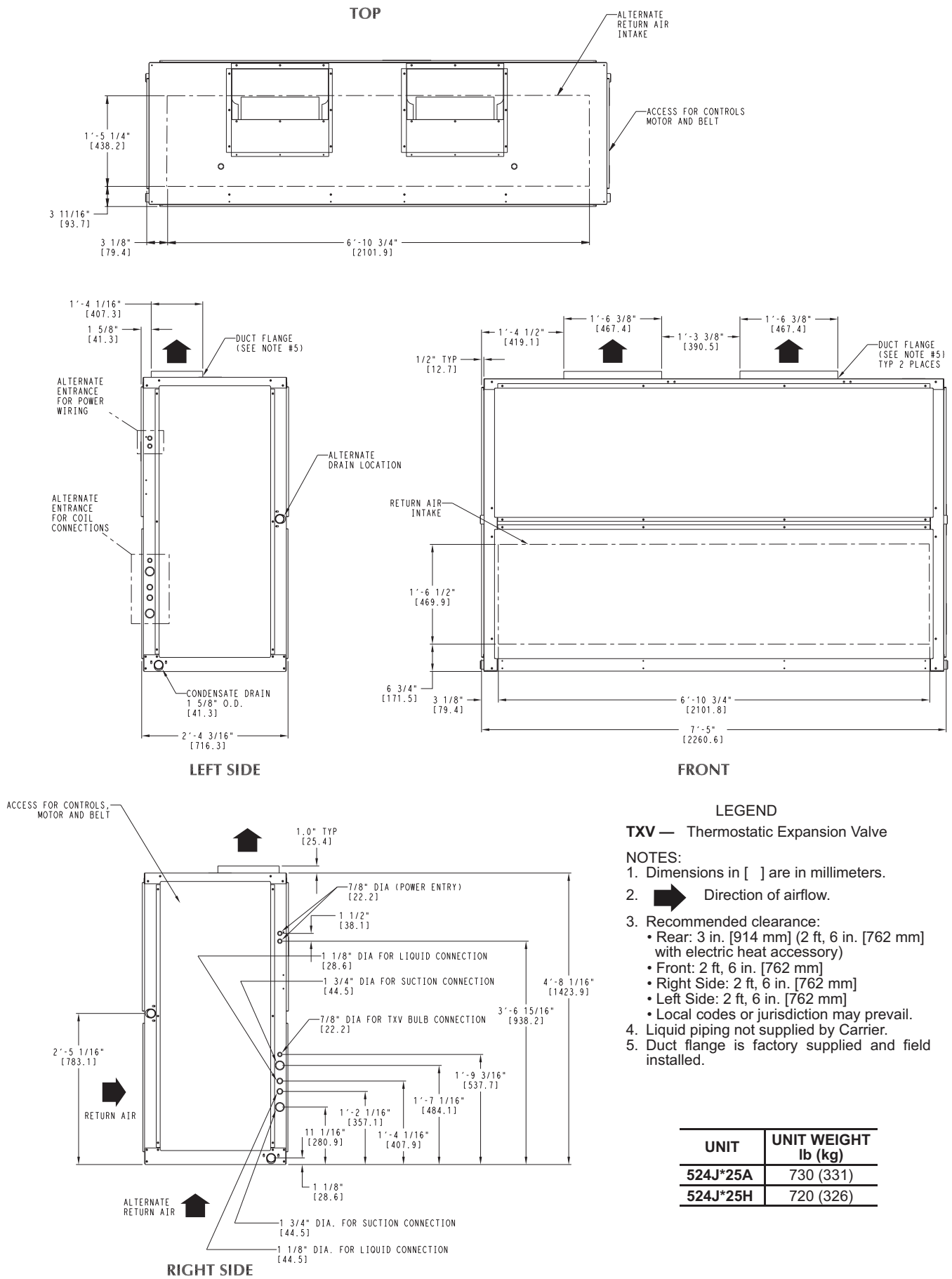

524J

Fig. 1 - Dimensions - Size 25

C10834

524J

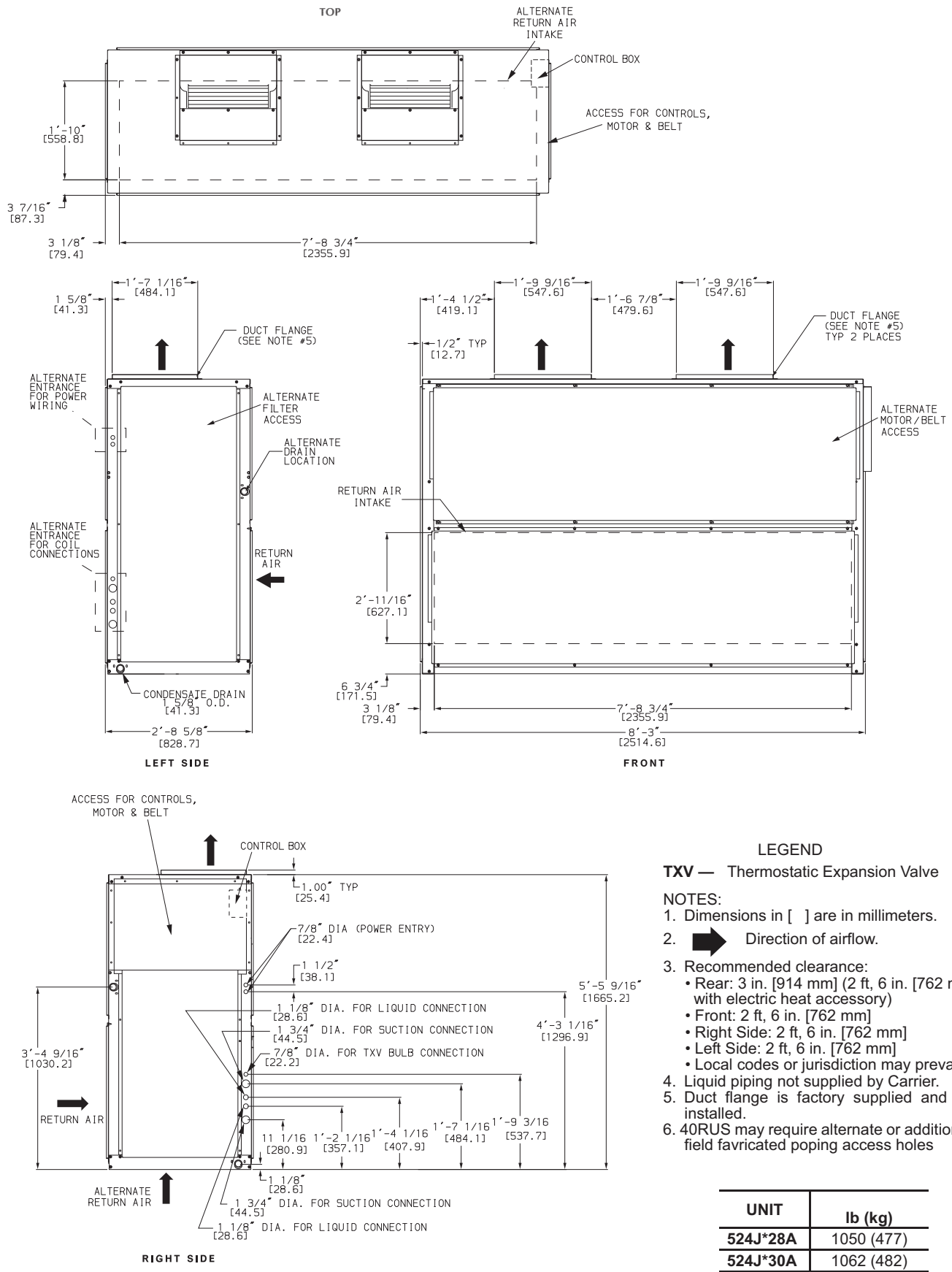

Fig. 2 - Dimensions – Sizes 28 and 30

C10835

1	2	3	4	5	6	7	8	9	10	11	12	13	14	15	16	17
5	2	4	J	E	2	5	A	0	0	0	A	2	0	A	A	A

Model Type

524J = Bryant Fan Coil
Puron® R-410A Refrigerant

Voltage

E = 460/3/60
P = 208/230/3/60
T = 575/3/60

Nominal Tonnage

25 = 20 Tons
28 = 25 Tons
30 = 30 Tons

Type of Coil

A = Standard DX Coil
B = High Capacity DX Coil
H = DX Coil for Heat Pump Duty

Not Used

0 = Not Used

Not Used

0 = Not Used

Packaging

A = Standard

Not Used

A = Not Used

Service Options

A = None
B = Painted Cabinet

Not Used

0 = Not Used

Indoor Fan Options

1 = Fan Drive and Motor - Low / Motor Efficiency - Standard
2 = Fan Drive and Motor - Med / Motor Efficiency - Standard
3 = Fan Drive and Motor - High / Motor Efficiency - Standard

Coil Options

A = Al/Cu

Not Used

0 = Not Used

524J

Fig. 3 - Model Number Nomenclature

C10837

POSITION NUMBER	1	2	3	4	5	6	7	8	9	10
TYPICAL	2	6	1	0	G	1	2	3	4	5

POSITION

1-2
3-4
5
6-10

DESIGNATES

Week of manufacture (fiscal calendar)
Year of manufacture ("10" = 2010)
Manufacturing location (G = ETP, Texas, USA)
Sequential number

Fig. 4 - Serial Number Nomenclature

C10725

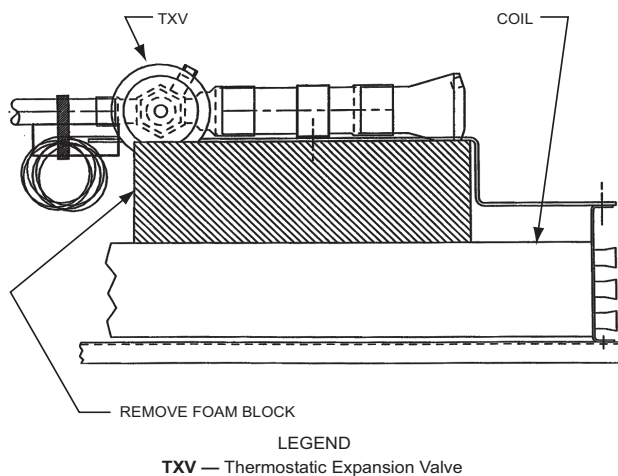

Fig. 5 - Foam Block Location

C10683

Unit Positioning - The unit can be mounted on the floor for vertical application with return air entering the face of the unit and supply air discharging vertically through the top of the unit. The unit can also be applied in a horizontal arrangement with return air entering

horizontally and the supply air discharging horizontally. When applying the unit in a horizontal arrangement, ensure the condensate drain pan is located at the bottom center of the unit for adequate condensate disposal. See Fig. 6 for condensate connections for each unit position.

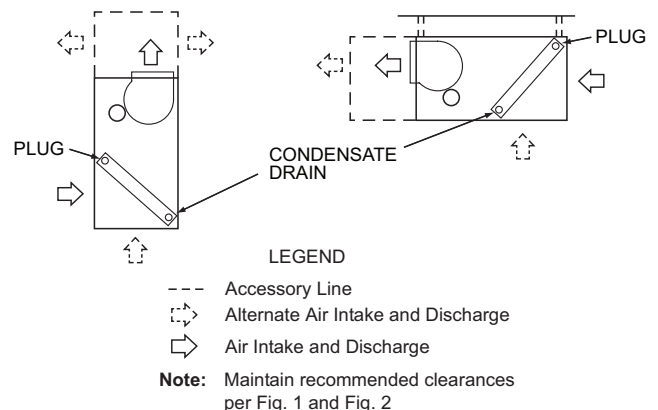

Fig. 6 - Typical Unit Positioning

C10684

Typical positioning and alternate return air locations are shown in Fig. 6. Alternate return air locations can be used by moving the unit panel from the alternate return air location to the standard return air location. Refer to overhead suspension accessory drawing (Fig. 7) for

preferred suspension technique. The unit needs support underneath to prevent sagging.

IMPORTANT: Do NOT attempt to install unit with return air entering top panel of unit. Condensate will not drain from unit.

OVERHEAD SUSPENSION ACCESSORY — UNIT SIZE 25

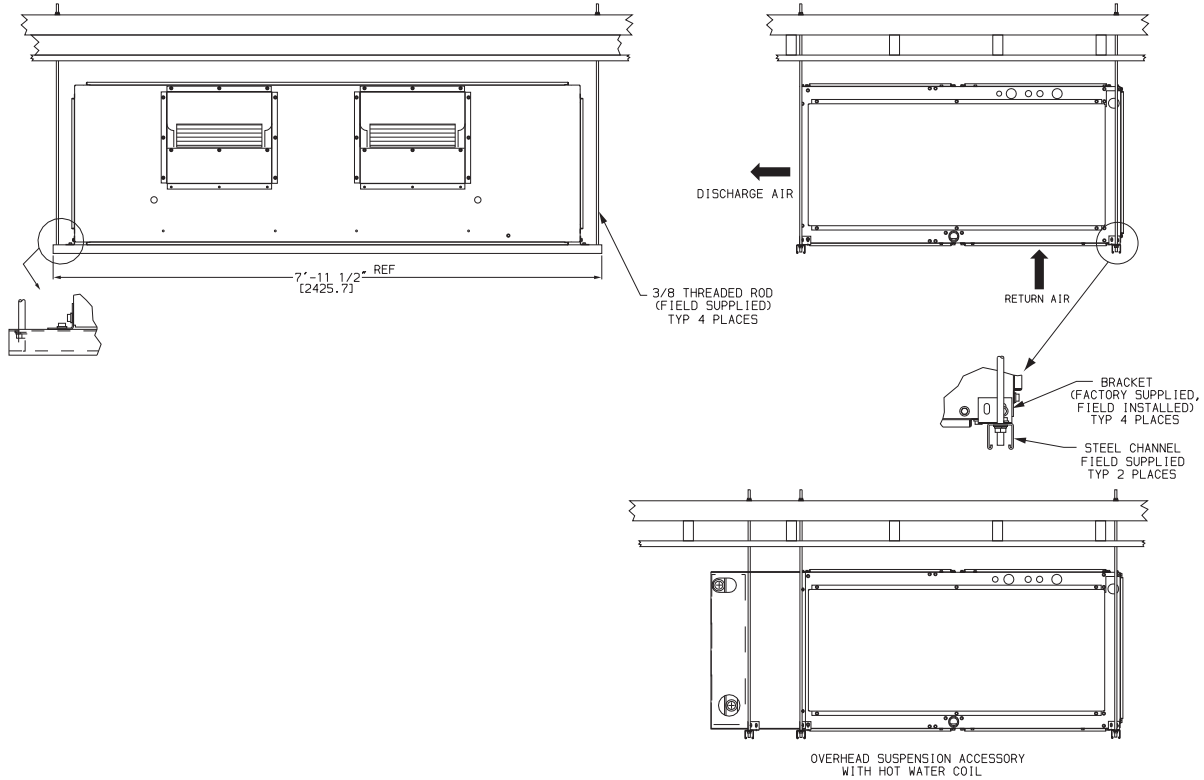

OVERHEAD SUSPENSION ACCESSORY — UNIT SIZES 28, 30

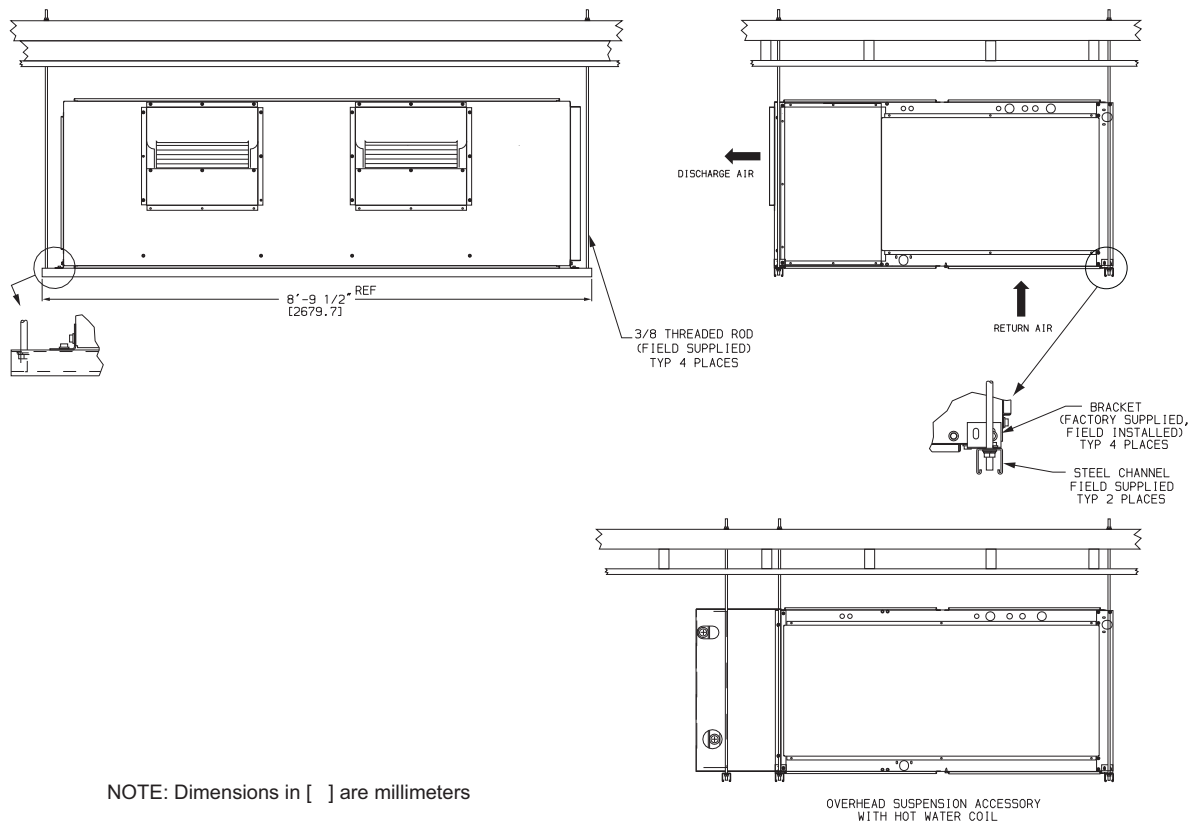

NOTE: Dimensions in [] are millimeters

Fig. 7 - Preferred Suspension Technique

C10728

Unit Isolation - Where extremely quiet operation is essential, install isolators between floor and base of unit, or between ceiling and top section of unit.

Be sure that unit is level and adequately supported. Use channels at front and sides of unit for reference points when leveling.

Refrigerant Piping Access - The 524J Series units come with standard knockouts for refrigerant piping. These knockouts are located on both sides of the unit for installation flexibility. The standard knockouts provide sufficient access to the unit's coils for all 524J*25A, 28A and 30A units. The 524J*25H requires additional holes which must be field-fabricated to accommodate the piping. See Fig. 8 for positions and dimensions for the additional access holes required. Recommended access hole use is also listed for all units. Note that Fig. 8 shows the access holes on the control-box side of the unit; this is the side of the unit with the coil headers, so it is used most often for piping access.

IMPORTANT: Do not bury refrigerant piping underground.

Refrigerant Piping - See Tables 1A–1D for refrigerant pipe connection sizes. For ease in brazing, it is recommended that all internal solder joints be made before unit is placed in final position.

The 524J direct-expansion units have internal factory-installed thermostatic expansion valves (TXVs), distributors, and nozzles for use with R-410A. See Table 2 for part numbers. Knockouts are provided in the unit corner posts for 524J refrigerant piping. See Fig. 8, which also lists recommended knockouts and access holes to use for each 524J unit size. Recommended fittings are listed in Table 3.

The sensor bulb capillary tubes must be routed from the TXVs inside the unit through one of the piping access holes. Clamp the TXV sensor bulb on a vertical portion of the suction line, outside the unit. See Fig. 9.

NOTE: Be sure to remove the styrofoam shipping pad from the TXV. Verify that it has been removed. See Fig. 5.

IMPORTANT: Never attach the sensor to the suction manifold. Do NOT mount the sensor on a trapped portion of the suction line.

The 524J Series evaporator coils have a face-split design. Ensure that lower circuit of coil is first on/last off when connected to the condensing unit and/or system controls. See Fig. 10.

External TXV equalizer connections are provided and factory-brazed into the coil suction manifolds.

If suction line must be horizontal, clamp bulb to suction line at least 45 degrees above bottom, at approximately the 4 o'clock or 8 o'clock position. See Fig. 11.

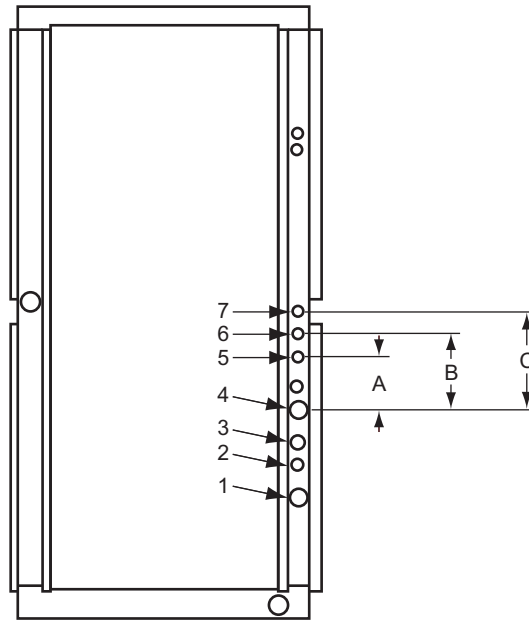

C10838

UNIT	USE HOLE NUMBERS	FIELD-FABRICATED HOLE DIAMETERS in. (mm)			FIELD-FABRICATED HOLE POSITION DIMENSIONS in. (mm)		
		No. 5	No. 6	No. 7	A	B	C
524J*25A, 28A, 30A	1, 2, 3, 4	—	—	—	—	—	—
524J*25H	3*, 5, 6, 7	1 ¹ / ₈ (28.6)	1 ¹ / ₈ (28.6)	1 ³ / ₄ (44.5)	3.25 (82.6)	6.125 (155.6)	10.38 (263.7)

*Must be enlarged from 1¹/₈ in. (28.6mm) to 1³/₄ in. (44.5mm)
NOTE: Access hole knockouts 1–4 are factory-supplied.

Fig. 8 - Refrigerant Piping Access Holes

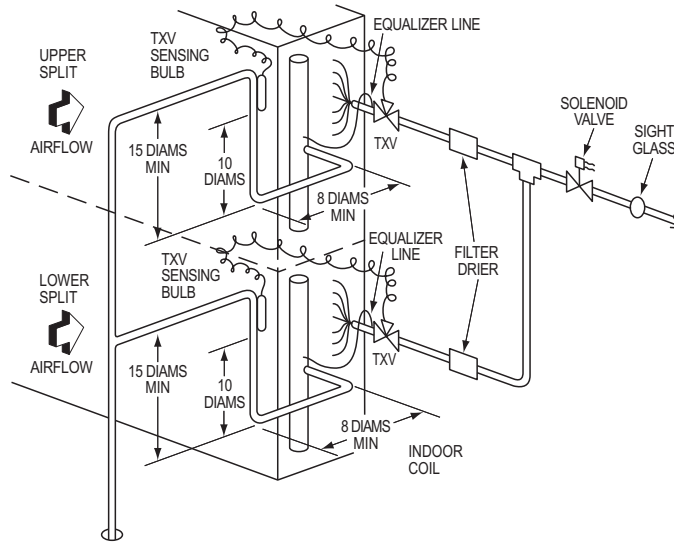

LEGEND:

TXV – Thermostatic Expansion Valve

NOTE: Component location arrangement shown for field installation of sight glasses, solenoid valves, filter driers, and TXV sensing bulbs. The TXVs and equalizer lines are factory installed.

Fig. 9 - Face-Split Coil Suction and Liquid Line Piping (Typical)

C10726

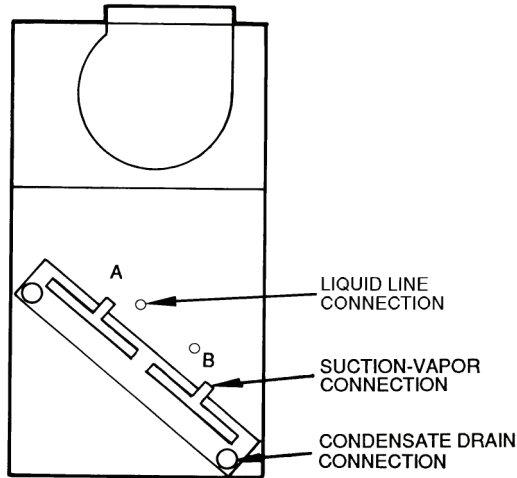

FIRST ON/LAST OFF = B
VERTICAL INSTALLATION

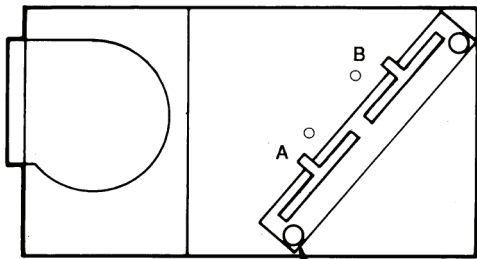

CONDENSATE DRAIN CONNECTION
FIRST ON/LAST OFF = A
HORIZONTAL INSTALLATION

C10688

Fig. 10 - Typical Evaporator Coil Connections (524J)

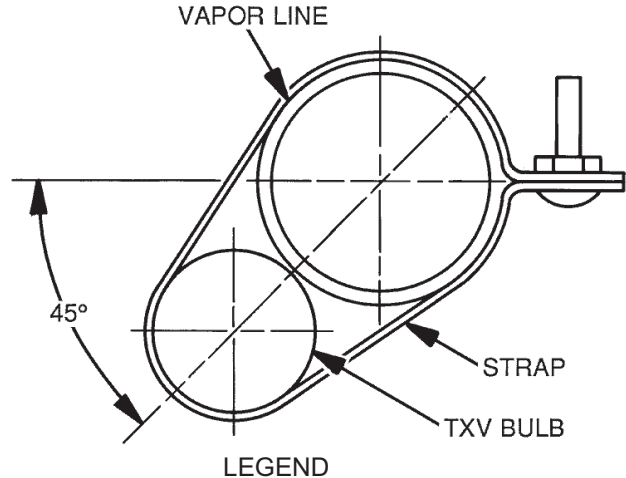

TXV — Thermostatic Expansion Valve

NOTE: The 8 o'clock position is shown above.

C10689

Fig. 11 - TXV Sensing Bulb Location

Table 2 – Factory-Installed Nozzle and Distributor Data

UNIT	COIL TYPE STD	TXV Qty...Part No.	DISTRIBUTOR Qty...Part No.	FEEDER TUBES PER DISTRIBUTOR [‡] Qty...Size (in.)	NOZZLE Qty...Part No.
524J*25A	4 Row	2...BBIZE-8-GA	2...D196-18- ³ / ₁₆	18... ³ / ₁₆	2...G6
524J*28A	4 Row	2...BBIZE-15-GA	2...1126	20... ³ / ₁₆	2...C15
524J*30A	4 Row	2...BBIZE-15-GA	2...1126	24... ³ / ₁₆	2...C17
524J*25H	4 Row	2...BBIZE-12.5-GA	2...113-12- ³ / ₁₆	2-12... ³ / ₁₆	2...G8

[‡] Feeder tube size is 1/4 in. (6.35 mm).

NOTE: Hot gas bypass applications require field-supplied auxiliary side connector.

Table 3 – Fitting Requirements

UNIT	ACCESS HOLE NO. [‡]	CONNECTION TYPE	CIRCUIT	FITTINGS REQUIRED [†] (in.)
524J*25A	1	Suction	Lower	1 ¹ / ₈ Street Elbow 1 ¹ / ₈ Nipple, 7 ⁵ / ₈ L 1 ¹ / ₈ Long Radius Elbow
	2	Liquid	Lower	5 ⁸ / ₈ Street Elbow 5 ⁸ / ₈ Nipple, 6 ¹ / ₂ L 5 ⁸ / ₈ Long Radius Elbow
	3	Liquid	Upper	5 ⁸ / ₈ Street Elbow 5 ⁸ / ₈ Nipple, 9 ¹ / ₂ L 5 ⁸ / ₈ Long Radius Elbow
	4	Suction	Upper	1 ¹ / ₈ Nipple, 5 ⁵ / ₈ L 1 ¹ / ₈ Long Radius Elbow 1 ¹ / ₈ Nipple, 11 L 1 ¹ / ₈ Long Radius Elbow
524J*25H	3	Suction	Lower	1 ¹ / ₈ Nipple, 3 L 1 ¹ / ₈ Long Radius Elbow
	5	Suction	Lower	5 ⁸ / ₈ Nipple, 2 ⁷ / ₈ L 5 ⁸ / ₈ 45° Elbow 5 ⁸ / ₈ Nipple, 1 ⁵ / ₈ L 5 ⁸ / ₈ Long Radius Elbow
	6	Liquid	Upper	5 ⁸ / ₈ Nipple, 2 ⁷ / ₈ L 5 ⁸ / ₈ 45° Elbow 5 ⁸ / ₈ Nipple, 4 ¹ / ₄ L 5 ⁸ / ₈ Long Radius Elbow
	7	Suction	Upper	1 ¹ / ₈ Nipple, 5 L 1 ¹ / ₈ 45° Elbow 1 ¹ / ₈ Nipple, 8 ³ / ₄ L 1 ¹ / ₈ Long Radius Elbow
524J*28A	1	Suction	Lower	1 ³ / ₈ Street Elbow 1 ³ / ₈ Nipple, 11 L 1 ³ / ₈ Long Radius Elbow
	2	Liquid	Lower	5 ⁸ / ₈ Street Elbow 5 ⁸ / ₈ Nipple, 1 ¹ / ₂ L 5 ⁸ / ₈ Long Radius Elbow
	3	Liquid	Upper	5 ⁸ / ₈ Street Elbow 5 ⁸ / ₈ Nipple, 19 ¹ / ₂ L 5 ⁸ / ₈ Long Radius Elbow
	4	Suction	Upper	1 ³ / ₈ Nipple, 4 ³ / ₁₆ L 1 ³ / ₈ Long Radius Elbow 1 ³ / ₈ Nipple, 23 ¹ / ₄ L 1 ³ / ₈ Long Radius Elbow

[‡] See Fig. 8 for access hole location by number.

[†] Fittings are listed in order from header or tee stub connection out to access hole in corner support post.

524J

Table 3 — Fitting Requirement (cont)

UNIT	ACCESS HOLE NO.‡	CONNECTION TYPE	CIRCUIT	FITTINGS REQUIRED† (in.)
524J*30A	1	Suction	Lower	1 ³ / ₈ Street Elbow 1 ³ / ₈ Nipple, 3 L 1 ³ / ₈ Long Radius Elbow
	2	Liquid	Lower	5 ⁸ / ₈ Street Elbow 5 ⁸ / ₈ Nipple, 7 ³ / ₄ L 5 ⁸ / ₈ Long Radius Elbow
	3	Liquid	Upper	5 ⁸ / ₈ Street Elbow 5 ⁸ / ₈ Nipple, 18 ¹ / ₂ L 5 ⁸ / ₈ Long Radius Elbow
	4	Suction	Upper	1 ³ / ₈ Nipple, 4 ³ / ₁₆ L 1 ³ / ₈ Long Radius Elbow 1 ³ / ₈ Nipple, 19 ¹ / ₄ L 1 ³ / ₈ Long Radius Elbow

‡ See Fig. 8 for access hole location by number.

† Fittings are listed in order from header or tee stub connection out to access hole in corner support post.

Condensate Drain - Install a trapped condensate drain line to unit connection as shown in Fig. 12. The unit drain connection is a PVC stub. See Fig. 13. Some areas may require an adapter to connect to either galvanized steel or copper pipe. For these applications, install a field-supplied threaded PVC adapter.

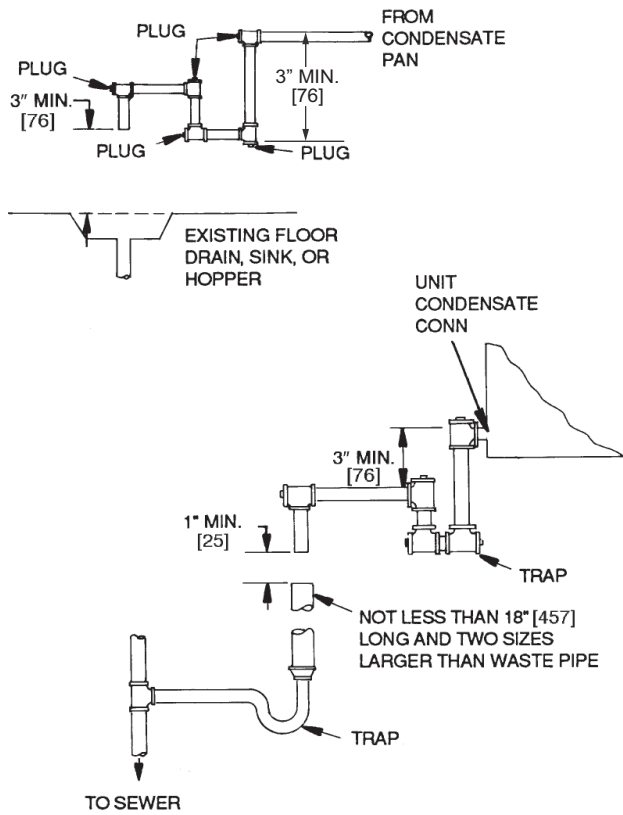

NOTE: Dimensions in [] are in millimeters

Fig. 12 - Condensate Drains

NOTE: A trap must be installed in the condensate drain line to ensure that the static pressure of fans is balanced with the water column in the drain line and that condensate can drain completely from pan. Without a trap, air can be drawn up drain line until water level in condensate pan becomes equal to static pressure created by fans, preventing complete drainage. Conditions will worsen as filters become dirty.

Install clean-out plugs in trap. Pitch drain line downward to an open floor drain or sump. Provide service clearance around drain line to permit removal of unit panels. Observe all local sanitary codes.

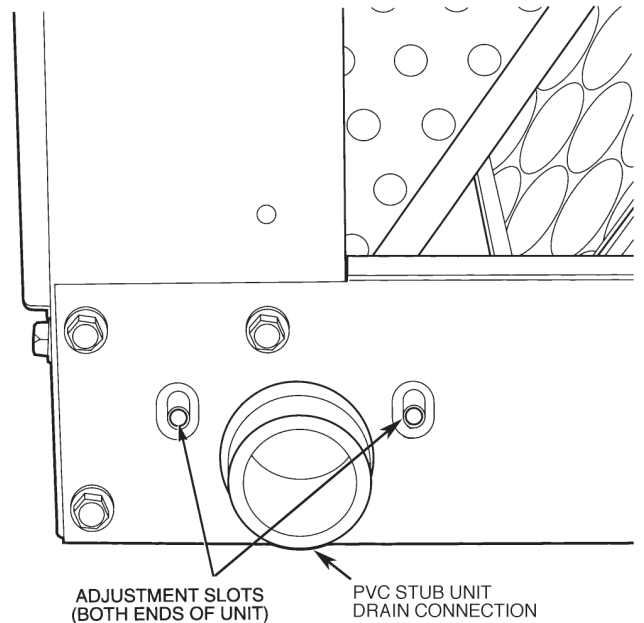

C10692

Fig. 13 - Drain Pan Slope Adjustment

As shipped, the unit's condensate drain pan is NOT sloped towards the drain connection. The pan slope must be changed to pitch towards the side of the unit with the drain connection. See Fig. 13. Loosen the 2 screws next to the drain outlet at both ends of the unit, push drain pan down in the slots near the drain connection, and up in the slots on the opposite end. Re-tighten screws. The pan should have a pitch of at least 1/4-in. over its length toward the drain connection.

C10691

Fan Motors and Drives - Motor and drive packages are factory installed in all units. The motor and drive packages consist of the following items:

- 1 — fan motor
- 1 — adjustable motor pulley
- 1 — fan pulley
- 2 — matched fan belts (524J*25A-30A units)

For instructions on changing fan rotation, changing drive speeds and adjusting drives, see Pulley and Drive Adjustment in the Service section.

Power Supply and Wiring - Check the unit data plate to ensure that available power supply matches electrical characteristics of the unit. Provide a disconnect switch with an integrated lock-out feature of size required to provide adequate fan motor starting current. See Tables 4-6 for unit electrical data.

⚠ WARNING

ELECTRICAL SHOCK HAZARD

Failure to follow this warning could result in personal injury or death.

Do not use gas piping as an electrical ground. Unit cabinet must have an uninterrupted, unbroken electrical ground to minimize the possibility of personal injury if an electrical fault should occur. This ground may consist of electrical wire connected to unit ground lug in control compartment, or conduit approved for electrical ground when installed in accordance with NEC (National Electrical Code); ANSI/NFPA 70, latest edition (in Canada, Canadian Electrical Code CSA [Canadian Standards Association] C22.1), and local electrical codes.

⚠ WARNING

FIRE HAZARD

Failure to follow this warning could result in intermittent operation or performance satisfaction.

Do not connect aluminum wire between disconnect switch and fan coil unit. Use only copper wire. (See Fig. 14)

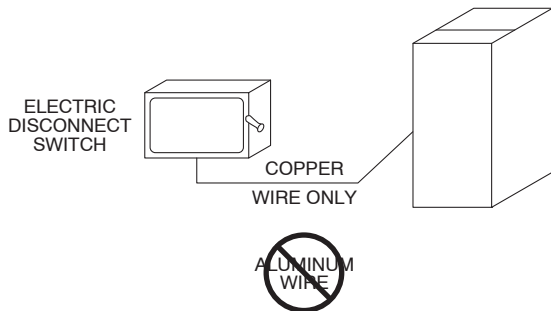
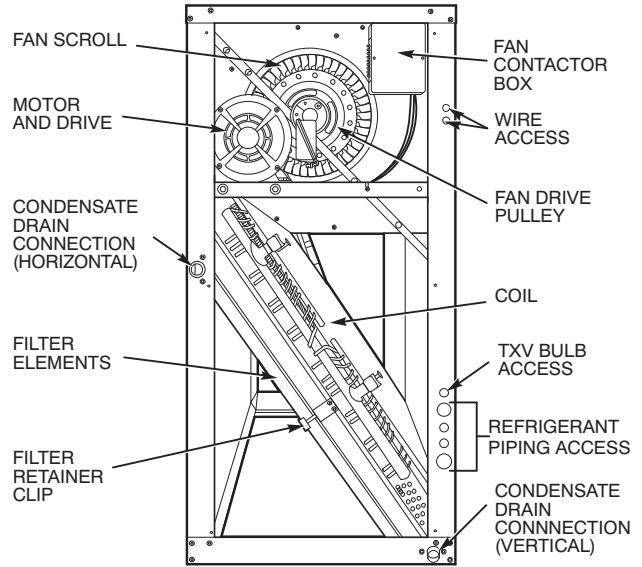

Fig. 14 - Disconnect Switch and Unit

A93033

Install disconnect switch and power wiring in accordance with all applicable local codes. See Fig. 14-16 and the unit label diagram. Connect power wiring with 1/4-in. ring terminal.



LEGEND
TXV — Thermostatic Expansion Valve

C10693

Fig. 15 - Wiring and Service Access (Side Panel Removed)

Fan motors are factory-installed on all units. Indoor-fan contactors are located in the fan contactor box behind the side access panel (see Fig. 15 and 16). Wire the thermostat to the 24-v control circuit terminal block located in the side of the fan contactor control box, according to Fig. 17 or the unit label diagram. If the air handler is part of a split system, complete the wiring from the condensing unit to the thermostat shown in Fig. 17.

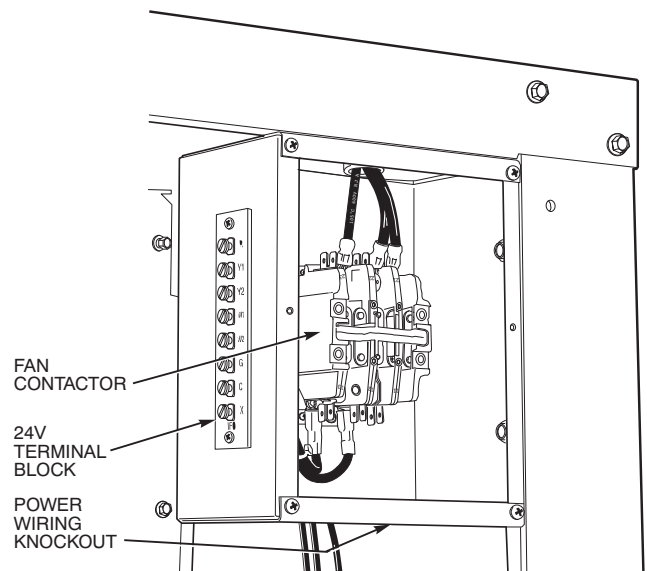

C10694

Fig. 16 - Fan Contactor Box and Terminal Block (Cover Removed) (Typical)

Table 4 – Electrical Data, Standard Motors

UNIT	V-PH-Hz†	VOLTAGE LIMITS	FAN MOTOR		POWER SUPPLY	
			Hp (kW)	FLA	Minimum Circuit Amps	MOCP
524J*25A 524J*25H	208/230-3-60	187-253	5.0 (3.73)	14.7/13.6	18.4/17.0	30/25
	460-3-60	414-506	5.0 (3.73)	6.8	8.5	15
	575-3-60	518-632	5.0 (3.73)	5.1	6.4	15
524J*28A	208/230-3-60	187-253	7.5 (5.59)	21.4/19.4	26.9/24.3	45/40
	460-3-60	414-506	7.5 (5.59)	9.7	12.1	20
	575-3-60	518-632	7.5 (5.59)	7.8	9.8	15
524J*30A	208/230-3-60	187-253	10.0 (7.46)	28.0/25.2	35.0/31.5	60/50
	460-3-60	414-506	10.0 (7.46)	12.6	15.8	25
	575-3-60	518-632	10.0 (7.46)	10.3	12.9	20

See Legend and Notes below.

Table 5 – Electrical Data, Alternate Motors

UNIT	V-PH-Hz*	VOLTAGE LIMITS	FAN MOTOR		POWER SUPPLY	
			Hp (kW)	FLA	Minimum Circuit Amps	MOCP
524J*25A 524J*25H	208/230-3-60	187-253	7.5 (5.59)	21.4/19.4	26.9/24.3	45/40
	460-3-60	414-506	7.5 (5.59)	9.7	12.1	20
	575-3-60	518-632	7.5 (5.59)	7.8	9.8	15
524J*28A 524J*30A	208/230-3-60	187-253	10.0 (7.46)	28.0/25.2	35.0/31.5	60/50
	460-3-60	414-506	10.0 (7.46)	12.6	15.8	25
	575-3-60	518-632	10.0 (7.46)	10.3	12.9	20

See Legend and Notes below.

Legend and Notes for Tables 4 and 5

LEGEND:

FLA – Full Load Amps

MOCP – Maximum Overcurrent Protection

† Motors are designed for satisfactory operation within 10% of normal voltage shown. Voltages should not exceed the limits shown in the Voltage Limits column.

NOTES:

1. Minimum circuit amps (MCA) and MOCP values are calculated in accordance with The NEC, Article 440.
2. Motor FLA values are established in accordance with Underwriters' Laboratories (UL), Standard 1995.
3. **Unbalanced 3-Phase Supply Voltage**
Never operate a motor where a phase imbalance in supply voltage is greater than 2%. Use the formula in the example (see column to the right) to determine the percentage of voltage imbalance.
4. Installation with Accessory Electric Heaters
Size the Field Power Wiring between the heater TB1 and the 524J indoor fan motor per NEC Article 430-28 (1) or (2) (depends on length of conduit between heater enclosure and 524J power entry location). Install wires in field-installed conduit.

Example: Supply voltage is 230-3-60

$$\% \text{ Voltage Imbalance} = 100 \times \frac{\text{max voltage deviation from average voltage}}{\text{average voltage}}$$



AB = 393 v
BC = 403 v
AC = 396 v

$$\text{Average Voltage} = \frac{(393 + 403 + 396)}{3} = \frac{1192}{3} = 397$$

Determine maximum deviation from average voltage.

(AB) 397 - 393 = 4 v

(BC) 403 - 397 = 6 v

(AC) 397 - 396 = 1 v

Maximum deviation is 4 v.

Determine percent of voltage imbalance.

$$\% \text{ Voltage Imbalance} = 100 \times \frac{6}{397} = 1.5\%$$

This amount of phase imbalance is satisfactory as it is below the maximum allowable 2%.

IMPORTANT: If the supply voltage phase imbalance is more than 2%, contact your local electric utility company immediately.

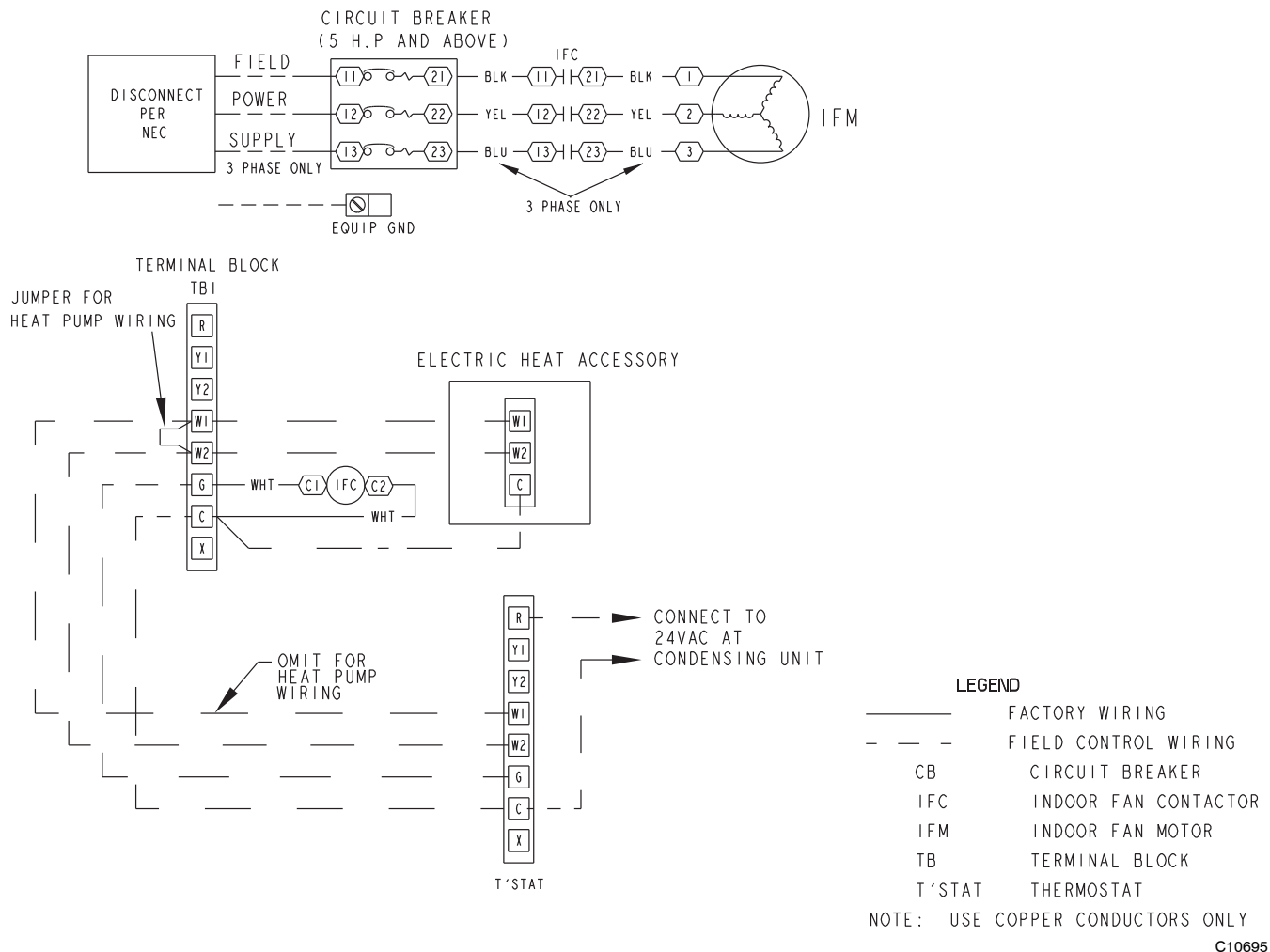

Fig. 17 - Unit Wiring

Table 6 – Fan Contactor Coil Data

UNIT 524J*	VOLTAGE (vac)	MAXIMUM HOLDING VA
25A, 25H, 28A, 30A	24	10

Connecting Ductwork - Refer to the System Design Manual for the recommended design and layout of ductwork. Fig. 18 shows recommended duct connection to units with 2 fans.

⚠ CAUTION

UNIT OPERATION HAZARD
 Failure to follow this caution could cause equipment damage.
 Do not operate unit without ductwork or discharge plenum unless fan speed has been adjusted for external static pressure of zero in. wg. Failure to do so may result in motor overload.

DISCHARGE CONNECTIONS — Duct flanges are factory-supplied; they are shipped inside the unit attached to the hairpin end of the coil tube sheet for field

installation. Using the existing screws, install the duct flanges on the unit's fan deck. Each fan discharge requires 2 flanges; each flange must be bent in the middle to conform to the discharge opening. See Fig. 19. After flanges are installed, connect them to the supply duct using a canvas connection to prevent vibration. It is important that this connection be properly fabricated to prevent high air friction losses and air noise.

RETURN CONNECTIONS — When using return-air ductwork, route return-air duct to the unit's return air inlet near the filter rack, using a canvas connection to prevent transmission of unit vibration. If the duct blocks off the unit's access panel, provide a slip joint in the ductwork to permit removal for servicing.

OUTDOOR-AIR INLET CONNECTIONS — Connect outdoor-air inlet to field-installed accessory economizer. Refer to Economizer Installation Instructions.

Return-Air Filters - Type and size of filters are shown in Tables 1A – 1D and are factory-supplied and factory-installed. In all units with 2 fans, a filter replacement tool (hook) is shipped inside the unit for field use when replacing filters. See the Service section for instructions on filter element replacement.

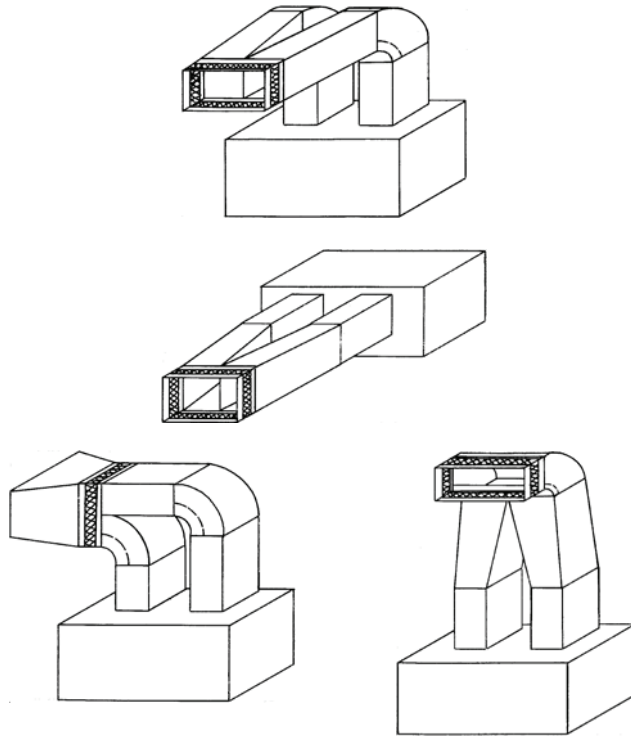

Fig. 18 - Typical Fan Discharge Connections for Multiple Fan Units

C10696

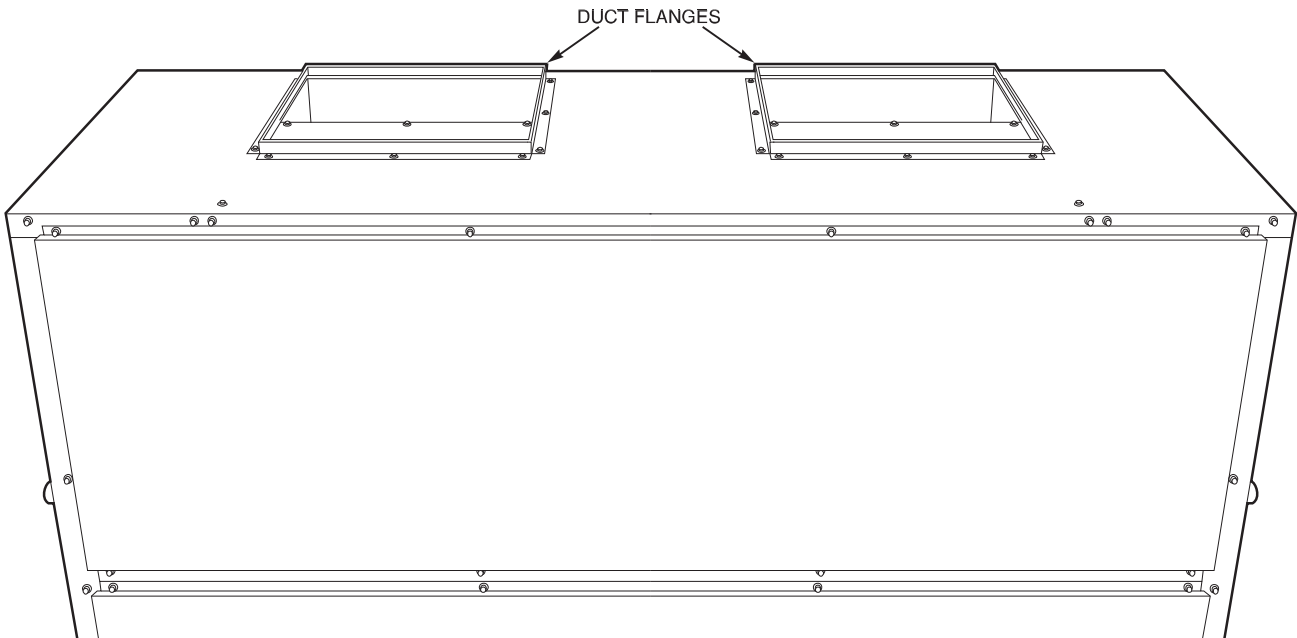

Fig. 19 - Duct Flange Installation

C10697

START-UP

Before starting unit, check the following and correct as necessary:

- Is unit solidly supported?
- Is fan adjusted for speed and pulley alignment?
- Are pulleys, motor, and bearings securely mounted?
- Are there any loose parts that will rattle or vibrate?
- Is condensate drain pan pitched for correct drainage?
- Are coil baffle plates tight against coil to prevent air bypass?
- Are all panels securely fastened?
- Are all electrical connections correct and tight?
- Is TXV bulb located on suction tube per Fig. 20?
- Is the capillary tube to the bulb free of kinks and not subject to pinching?
- Is the bulb well secured to the suction tube with strap?

Also refer to condensing unit or outdoor heat pump section instructions before starting a split system. A split system start-up checklist is provided at the end of these instructions.

2. To increase superheat, turn the stem clockwise. To decrease the superheat, turn the stem counterclockwise. Do not turn the stem more than one full turn.
3. Wait until suction pressure and superheat stabilize. This may take more than 30 minutes.
4. Continue adjustment until superheat reaches 10°F to 15°F (5.5°C to 8.3°C).
5. Replace the seal cap; tighten.

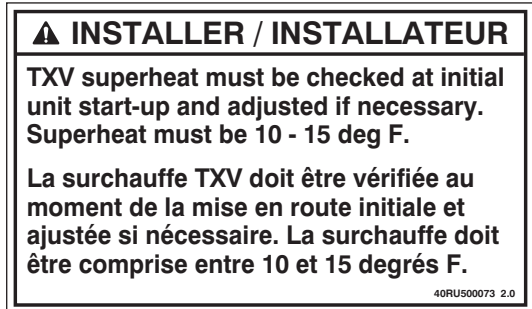

Fig. 21 - Label, TXV Adjustment

C10828

524J

SERVICE

Inspection and maintenance should be performed at regular intervals and should include the following:

- Complete cleaning of cabinet, fan wheel, cooling coil, condensate pan and drain, heating coils, and return-air grille (if present).
- Inspection of panels and sealing of unit against air leakage.
- Adjustment of fan motor, belt, bearings, and wheels.
- Cleaning or replacement of filters.
- Testing for cooling/heating system leaks.
- Checking of all electrical connections.

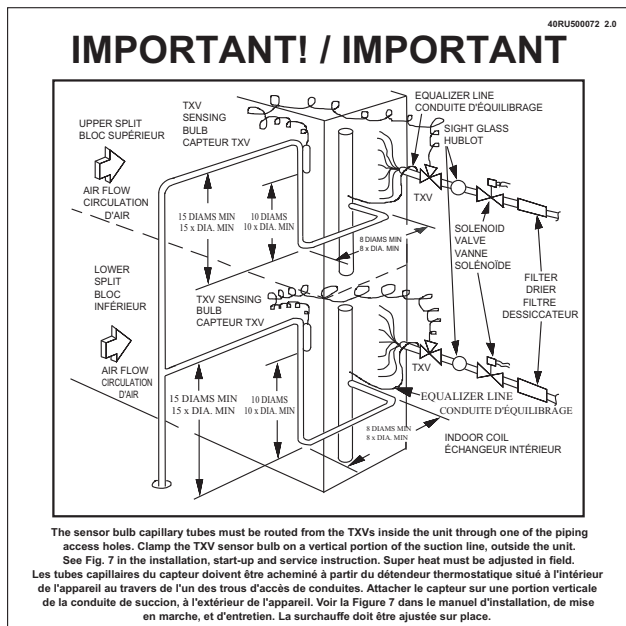

Fig. 20 - Label, TXV Bulb Location

C10827

Adjusting TXV for Superheat —

The unit-mounted thermostatic expansion valve(s) is/are factory set to provided superheat at the bulb location in 10°F to 15°F (5.5°C to 8.3°C) range. Actual system load conditions may require adjustment of the factory setting. To adjust the TXV superheat setting:

1. Remove the seal cap from the bottom of the TXV body.

▲ WARNING

ELECTRICAL SHOCK HAZARD

Failure to follow this warning could result in personal injury or death.

Before performing service or maintenance operations on unit, always turn off main power switch to unit and install lockout tag. Unit may have more than one power switch.

Most unit service can be performed by removing one or both of the unit's side panels. Coil cleaning or removal or insulation cleaning may require removal of a rear, top, or bottom panel, depending on the unit's orientation. When service is completed, replace unit panels.

Panels - Panels are fastened to unit frame with sheet metal screws. Fan and coil compartment must be sealed tightly after service to prevent air from bypassing the cooling coil.

Fan Motor Lubrication - Fan motor supplied with unit is permanently lubricated and requires no further lubrication.

Fan Shaft Bearings - Size 25-30 units have pillow-block bearings (Fig. 22) that must be lubricated with suitable bearing grease approximately every 3 months. See Table 7 for suitable lubricants.

Table 7 – Lubricant Data

MANUFACTURER	LUBRICANT
Mobil	Mobilplex EP No. 2
Sunoco	Prestige 42
Texaco	Multifak 2
Texaco	Regal AFB-2*

*Preferred lubricant, contains rust and oxidation inhibitors.

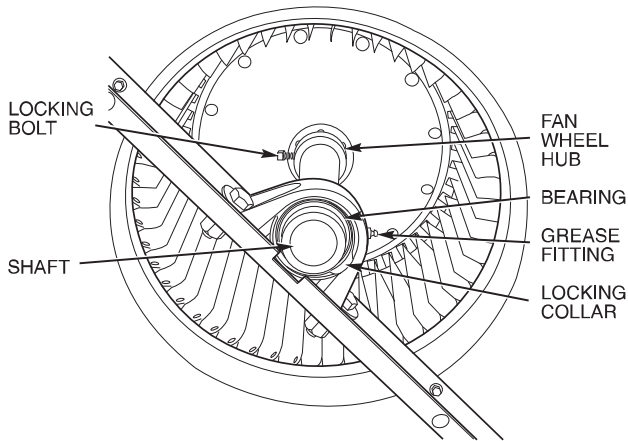

C10698

Fig. 22 - Fan Shaft, Bearings, and Fan Wheel (Typical)

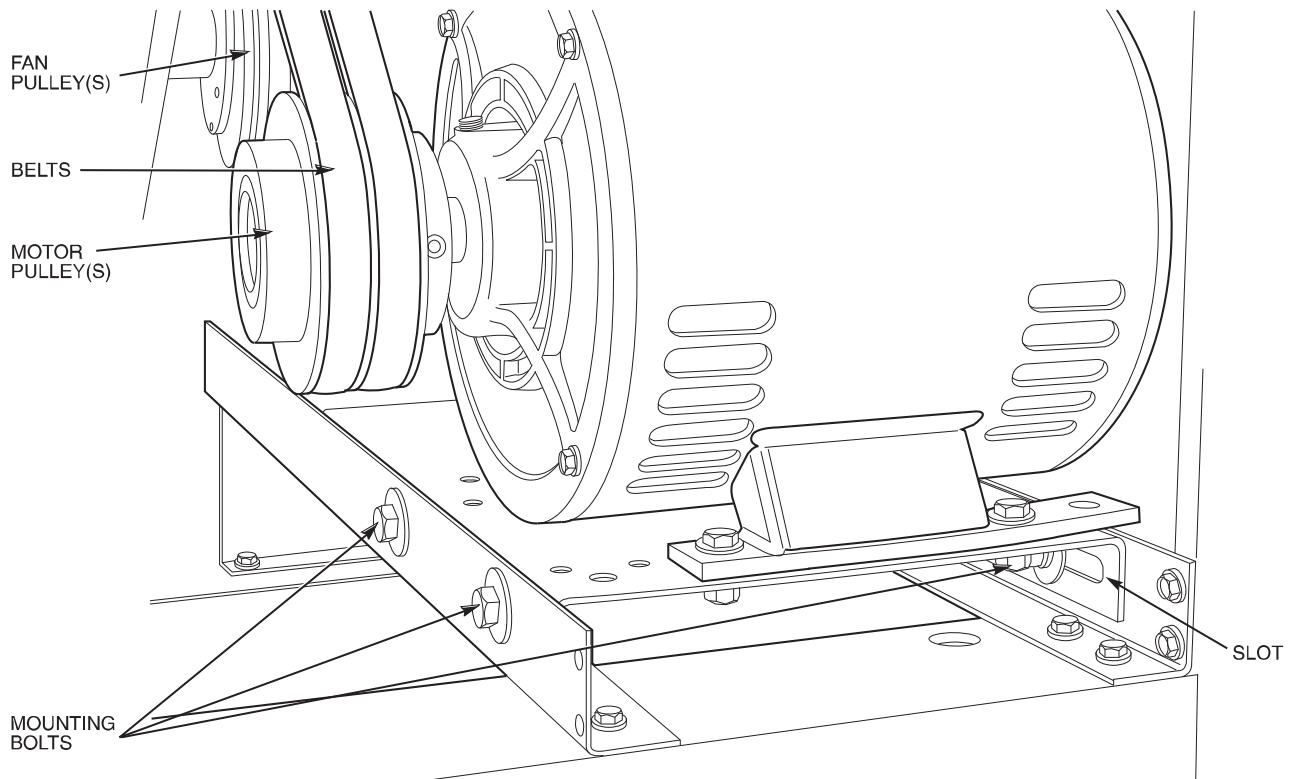

C10700

Fig. 24 - Fan Motor Mounting

Centering Fan Wheel - If fan and fan shaft assembly are not properly centered, blades may scrape against the blower side scroll plate or may create an objectionable whistling noise. It may be necessary to adjust individual fan wheels or move entire fan shaft. See the following two sections.

Fan Shaft Position Adjustment - Loosen setscrew or locking collar of each fan shaft bearing. Slide shaft into correct position and replace locking collar (Fig. 23). To replace locking collar, push collar up against inner face of bearing. Turn collar in direction of fan rotation until tight, and tighten setscrew. Tightening locking collar in direction of fan rotation results in further tightening of collar should setscrew work itself loose.

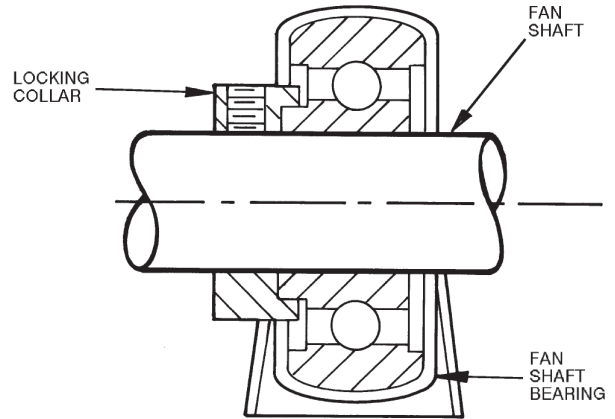

C10699

Fig. 23 - Fan Shaft Bearing

Individual Fan Wheel Adjustment - Loosen the 2 locking bolts holding fan wheel hub to shaft. See Fig. 22. Position fan wheel in center of the fan housing and tighten locking bolts. Clearance between wheel and housing should be the same on both sides.

Fan Belts - Motor mounting plate and motor support angles are slotted to permit both vertical and horizontal adjustment. Adjust belt(s) for correct deflection by loosening motor plate mounting bolts, moving motor/plate assembly forward or back, and re-tightening bolts. Press down on belt with one finger midway between fan and motor pulleys to check deflection. The correct deflection is $\frac{1}{8}$ -in. (3.2 mm). See Fig. 24.

If complete belt replacement is required during servicing, loosen the motor plate mounting bolts (Fig. 24), move motor/plate assembly towards fan pulley, and pull belt(s) off pulleys. Reverse the procedure with new bolts and readjust deflection.

Fan Rotation - Correct fan rotation with respect to fan outlet is shown in Fig. 25.

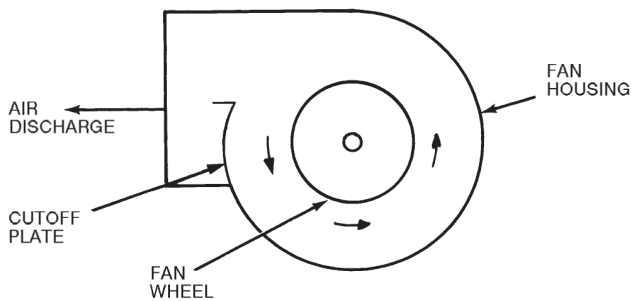

Fig. 25 - Fan Rotation

C10701

To reverse the direction of rotation of a 3-phase fan motor, reverse any 2 of the power leads. Refer to the connection diagram on the inside of motor terminal box cover for proper reversing procedure of single-phase motor.

Fan Pulley Alignment - Align as follows:

1. Loosen setscrews on pulleys.
2. Align pulleys visually and tighten setscrews on fan pulley to lock it in place.
3. Use the methods shown in Fig. 26 to check proper pulley alignment.
4. If pulleys are not in correct alignment, loosen the motor holddown bolts and slide the motor axially until the pulleys are aligned.
5. Tighten motor holddown bolts.

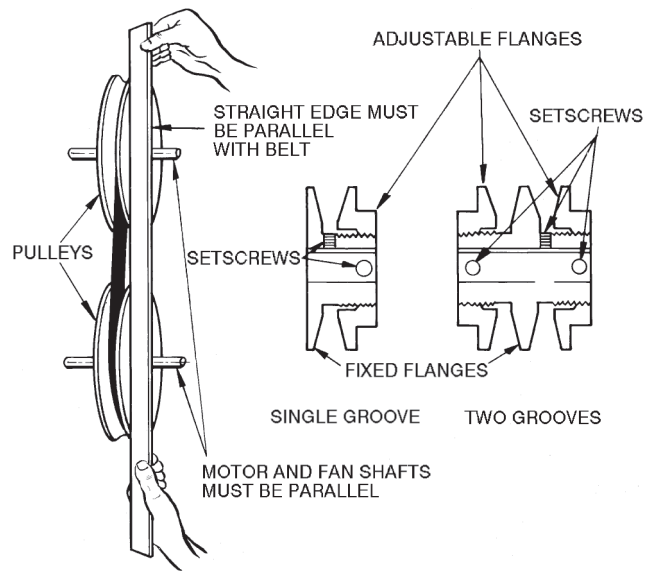

Fig. 26 - Fan Pulley Adjustments

C10702

Pulley and Drive Adjustment - To obtain desired fan speed, refer to the fan motor and drive data in Tables 8A-11D and adjust fan motor pulley as follows:

1. Remove belt from fan motor pulley after loosening motor from motor base.
2. Loosen setscrew in moveable flange of pulley. Screw moveable flange toward fixed flange to increase the fan speed and away from fixed flange to reduce speed. Before tightening setscrew, make certain that setscrew is over nearest flat surface of pulley hub (Fig. 26).

⚠ CAUTION

UNIT OPERATION HAZARD

Failure to follow this caution could cause equipment damage.

Increasing fan speed produces a greater load on motor. Do not exceed rated capacity of motor.

Condensate Drains - Keep condensate drains free of dirt and foreign matter.

Return-Air Filters - Refer to Replacing Filters section for filter accessibility and removal. Replace with clean filters of the sizes listed in Tables 1A-1F.

- After draining as much water as possible from coils, add sufficient antifreeze to prevent residual water in the coil from freezing.
- Add a sufficient quantity of non-corrosive antifreeze to the entire system to prevent all water within the system from freezing.

Coil Removal - Remove unit panels and corner posts as required. Disconnect coil connections and remove fastening screws. Remove coil through end or side sections of unit.

Cleaning Cooling Coil - Remove return-air filters. Remove any heavy dirt that may have accumulated on underside of coil. Coil can be cleaned more easily with a stiff brush, vacuum cleaner, or compressed air when coil is dry. If coil is wet or if water is to be used for cleaning, guard against splashing water on electrical components or damaging surrounding area. Clean coil baffles as applicable and check for tight fit to be sure air does not bypass coil.

Cleaning Insulation - The insulation contains an immobilized antimicrobial agent that helps prevent the growth of bacteria and fungi. Clean the inner surface of the insulation according to the separate maintenance instructions shipped with the unit.

Replacing Filters - Filters can be removed and installed from either side of the unit. Install new filters in units that have one fan as follows:

1. Remove the side access panel (retain screws).
2. Remove the filter retainer clip (see Fig. 27).
3. Remove old filters by lifting and tilting them out of the filter track. See Fig. 15 and 28. Use the factory-supplied filter hook to slide filters within reach for removal. The filter hook is shipped inside the unit in the filter track.
4. Reverse the procedure to install new filters.

⚠ CAUTION

UNIT OPERATION HAZARD

Failure to follow this caution could cause equipment damage.

Do not operate unit without air filters.

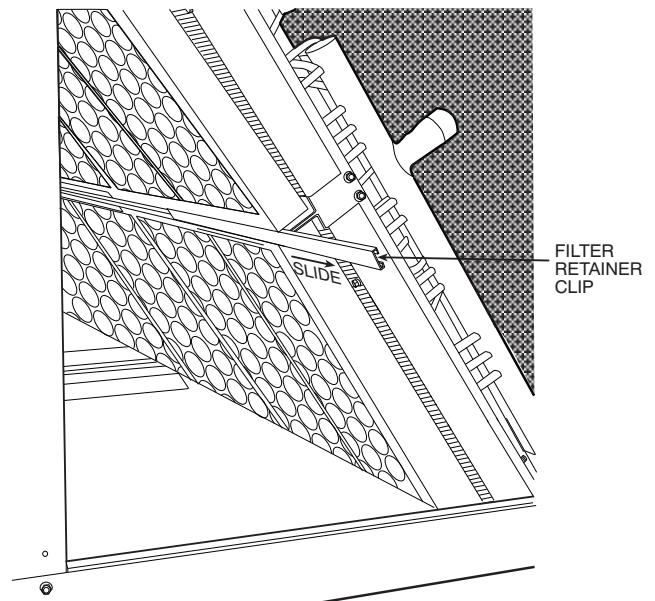

Fig. 27 - Remove Filter Retainer Clip

C10703

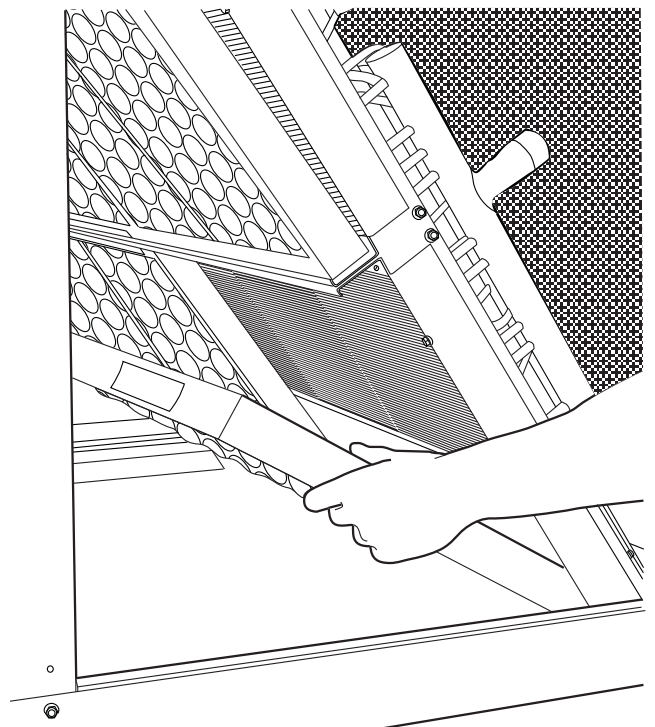

Fig. 28 - Filter Removal/Replacement

C10704

Table 8A - Fan Motor Data, Standard Motor — English

UNIT	524J*25A 524J*25H	524J*28A	524J*30A
208/230-3-60 and 460-3-60			
Speed (rpm)	1745	1745	1745
Hp	5.0	7.5	10.0
Frame (NEMA)	S184T	S213T	S215T
Shaft Dia (in.)	1 ¹ / ₈	1 ³ / ₈	1 ³ / ₈
575-3-60			
Speed (rpm)	1745	1755	1755
Hp	5.0	7.5	10.0
Frame (NEMA)	184T	S213T	D215T
Shaft Dia (in.)	1 ¹ / ₈	1 ³ / ₈	1 ³ / ₈

LEGEND

NEMA — National Electrical Manufacturers Association

Table 8B - Fan Motor Data, Alternate Motor — English

UNIT	524J*25A 524J*25H	524J*28A	524J*30A
208/230-3-60 and 460-3-60			
Speed (rpm)	1745	1745	1745
Hp	7.5	10.0	10.0
Frame (NEMA)	S213T	S215T	S215T
Shaft Dia (in.)	1 ³ / ₈	1 ³ / ₈	1 ³ / ₈
575-3-60			
Speed (rpm)	1755	1750	1750
Hp	7.5	10.0	10.0
Frame (NEMA)	S213T	D215T	D215T
Shaft Dia (in.)	1 ³ / ₈	1 ³ / ₈	1 ³ / ₈

LEGEND

NEMA — National Electrical Manufacturers Association

Table 8C - Fan Motor Data, Standard Motor — SI

UNIT	524J*25A 524J*25H	524J*28A	524J*30A
208/230-3-60 and 460-3-60			
Speed (r/s)	29.08	29.08	29.08
Shaft kW	3.73	5.60	7.46
Frame (NEMA)	S184T	S213T	S215T
Shaft Dia (mm)	28.6	34.9	34.9
575-3-60			
Speed (r/s)	29.08	29.25	29.25
Shaft kW	3.73	5.60	7.46
Frame (NEMA)	184T	S213T	S215T
Shaft Dia (mm)	28.6	34.9	34.9

LEGEND

NEMA — National Electrical Manufacturers Association

Table 8D - Fan Motor Data, Alternate Motor — SI

UNIT	524J*25A 524J*25H	524J*28A	524J*30A
208/230-3-60 and 460-3-60			
Speed (r/s)	29.08	29.17	29.17
Shaft kW	5.60	7.46	7.46
Frame (NEMA)	S213T	S215T	S215T
Shaft Dia (mm)	34.9	34.9	34.9
575-3-60			
Speed (r/s)	29.25	29.17	29.17
Shaft kW	5.60	7.46	7.46
Frame (NEMA)	S213T	D215T	D215T
Shaft Dia (mm)	34.9	34.9	34.9

LEGEND

NEMA — National Electrical Manufacturers Association

Table 9A - Standard Drive Data, 60 Hz — English

UNIT	524J*25A 524J*25H	524J*28A	524J*30A
MOTOR DRIVE			
Motor Pulley Pitch Diameter (in.)	3.7–4.7	4.3–5.3	4.3–5.3
Pulley Factory Setting Full Turns Open	3.0	3.0	3.0
FAN DRIVE			
Pulley Pitch Dia (in.)	9.4	11.0	11.0
Pulley Bore (in.)	1 ⁷ / ₁₆	1 ¹⁵ / ₁₆	1 ¹⁵ / ₁₆
Belt No. — Section	2—B	2—B [†]	2—B [†]
Belt Pitch (in.)	41.8	(2) 42.8 (2) 43.8	(2) 42.8 (2) 43.8
FAN SPEEDS (rpm)			
Factory Setting	771	752	752
Range	679–863	682–841	674–831
Max Allowable Speed (rpm)	1200	1100	1100
Change per 1/2 Turn of Moveable Motor Pulley Flange	15.3	13.1	13.1
MAX FULL TURNS FROM CLOSED POSITION	6	6	6
SHAFTS CENTER DISTANCE (in.)	9.12–10.99	6.67–9.43	6.67–9.43

† Four belts shipped with unit. Use correct set of 2 belts sized according to the pulley setting.

Table 9B - Medium-Static Drive Data, 60 Hz — English

UNIT	524J*25A 524J*25H	524J*28A	524J*30A
MOTOR DRIVE			
Motor Pulley Pitch Diameter (in.)	4.3–5.3	4.3–5.3	4.3–5.3
Pulley Factory Setting Full Turns Open	3.0	3.0	3.0
FAN DRIVE			
Pulley Pitch Dia (in.)	9.4	9.4	9.4
Pulley Bore (in.)	1 ⁷ / ₁₆	1 ¹⁵ / ₁₆	1 ¹⁵ / ₁₆
Belt No. — Section	1—B	2—B [†]	2—B [†]
Belt Pitch (in.)	41.8	(2) 38.8 (2) 39.8	(2) 38.8 (2) 39.8
FAN SPEEDS (rpm)			
Factory Setting	881	881	881
Range	798–984	798–984	798–984
Max Allowable Speed (rpm)	1200	1100	1100
Change per 1/2 Turn of Moveable Motor Pulley Flange	15.3	15.3	15.3
MAX FULL TURNS FROM CLOSED POSITION	6	6	6
SHAFTS CENTER DISTANCE (in.)	9.16–10.99	6.67–9.43	6.67–9.43

† Four belts shipped with unit. Use correct set of 2 belts sized according to the pulley setting.

Table 9C - High-Static Drive Data, 60 Hz — English

UNIT	524J*25A 524J*25H	524J*28A	524J*30A
MOTOR DRIVE			
Motor Pulley Pitch Diameter (in.)	4.3–5.3	4.3–5.3	4.3–5.3
Pulley Factory Setting Full Turns Open	3.0	3.0	3.0
FAN DRIVE			
Pulley Pitch Dia (in.)	7.4	8.6	8.6
Pulley Bore (in.)	1 ⁷ / ₁₆	1 ¹⁵ / ₁₆	1 ¹⁵ / ₁₆
Belt No. — Section	2—B	2—B	2—B
Belt Pitch (in.)	36.8	37.8	37.8
FAN SPEEDS (rpm)			
Factory Setting	1118	1024	1024
Range	1014–1200 [†]	873–1075	873–1075
Max Allowable Speed (rpm)	1200	1100	1100
Change per 1/2 Turn of Moveable Motor Pulley Flange	19.4	16.7	16.7
MAX FULL TURNS FROM CLOSED POSITION	6	6	6
SHAFTS CENTER DISTANCE (in.)	8.16–10.02	6.67–9.43	6.67–9.43

[†] It is possible to adjust drive so that fan speed exceeds maximum allowable. DO NOT exceed 1200 rpm.

Table 9D- Standard Drive Data, 60 Hz — SI

UNIT	524J*25A 524J*25H	524J*28A	524J*30A
MOTOR DRIVE			
Motor Pulley Pitch Diameter (mm)	94.0–119.4	109.2–134.6	109.2–134.6
Pulley Factory Setting Full Turns Open	3.0	3.0	3.0
FAN DRIVE			
Pulley Pitch Dia (mm)	239	279	279
Pulley Bore (mm)	36.5	49.2	49.2
Belt No. — Section	2—B	2—B [†]	2—B [†]
Belt Pitch (mm)	1062	(2) 1987 (2) 1113	(2) 1987 (2) 1113
FAN SPEEDS (r/s)			
Factory Setting	12.9	12.5	12.5
Range	11.3–14.4	11.4–14.0	11.2–13.9
Max Allowable Speed (r/s)	20.0	18.3	18.3
Change per 1/2 Turn of Moveable Motor Pulley Flange	0.255	0.218	0.218
MAX FULL TURNS FROM CLOSED POSITION	6	6	6
SHAFTS CENTER DISTANCE (mm)	232–279	169–240	169–240

[†] Four belts shipped with unit. Use correct set of 2 belts sized according to the pulley setting.

Table 9E - Medium-Static Drive Data, 60 Hz — SI

UNIT	524J*25A 524J*25H	524J*28A	524J*30A
MOTOR DRIVE			
Motor Pulley Pitch Diameter (mm)	109.2–134.6	109.2–134.6	109.2–134.6
Pulley Factory Setting Full Turns Open	3.0	3.0	3.0
FAN DRIVE			
Pulley Pitch Dia (mm)	239	239	239
Pulley Bore (mm)	36.5	49.2	49.2
Belt No. — Section	1—B	2—B†	2—B†
Belt Pitch (mm)	1062	(2) 986 (2) 1011	(2) 986 (2) 1011
FAN SPEEDS (r/s)			
Factory Setting	14.7	14.7	14.7
Range	13.3–16.4	13.3–16.4	13.3–16.4
Max Allowable Speed (r/s)	20.0	18.3	18.3
Change per 1/2 Turn of Moveable Motor Pulley Flange	0.255	0.255	0.255
MAX FULL TURNS FROM CLOSED POSITION	6	6	6
SHAFTS CENTER DISTANCE (mm)	232–279	169–240	169–240

† Four belts shipped with unit. Use correct set of 2 belts sized according to the pulley setting.

Table 9F - High-Static Drive Data, 60 Hz — SI

UNIT	524J*25A 524J*25H	524J*28A	524J*30A
MOTOR DRIVE			
Motor Pulley Pitch Diameter (mm)	109.2–134.6	109.2–134.6	109.2–134.6
Pulley Factory Setting Full Turns Open	3.0	3.0	3.0
FAN DRIVE			
Pulley Pitch Dia (mm)	188	203†	203
Pulley Bore (mm)	36.5	49.2	49.2
Belt No. — Section	2—B	2—B	2—B
Belt Pitch (mm)	935	935	960
FAN SPEEDS (r/s)			
Factory Setting	18.6	17.1	17.1
Range	16.9–20.0†	14.6–17.9	14.6–7.9
Max Allowable Speed (r/s)	20.0	18.3	18.3
Change per 1/2 Turn of Moveable Motor Pulley Flange	0.323	0.278	0.278
MAX FULL TURNS FROM CLOSED POSITION	6	6	6
SHAFTS CENTER DISTANCE (mm)	207–255	169–240	169–240

† It is possible to adjust drive so that fan speed exceeds maximum allowable. DO NOT exceed 20 r/s

**Table 10A - 524J Standard Fan Performance Data —
0.0-2.4 in. wg External Static Pressure — English**

UNIT	AIRFLOW (Cfm)	EXTERNAL STATIC PRESSURE (in. wg)													
		0.0		0.2		0.4		0.6		0.8		1.0		1.2	
		Rpm	Bhp	Rpm	Bhp	Rpm	Bhp	Rpm	Bhp	Rpm	Bhp	Rpm	Bhp	Rpm	Bhp
524J*25A 524J*25H	6,000	532	1.25	569	1.39	639	1.69	711	2.06	781	2.48	846	2.93	905	3.60
	7,000	608	1.93	641	2.09	702	2.42	763	2.08	824	3.23	885	3.71	943	4.23
	8,000	686	2.83	716	3.01	770	3.38	823	3.77	876	4.21	930	4.70	983	5.24
	9,000	764	3.97	791	4.18	841	4.59	888	5.02	935	5.47	982	5.96	1030	6.51
	10,000	843	5.38	868	5.62	914	6.09	957	6.55	1000	7.02	1042	7.53	1084	8.08
524J*28A	7,500	456	1.29	490	1.47	556	1.85	621	2.25	678	2.64	729	3.06	778	3.60
	8,750	521	1.98	551	2.18	608	2.61	664	3.07	720	3.53	770	3.99	816	4.45
	10,000	587	2.88	614	3.11	664	3.59	714	4.09	763	4.62	812	5.15	857	5.68
	11,250	653	4.03	678	4.29	724	4.82	768	5.37	812	5.95	856	6.54	899	7.14
	12,500	720	5.46	743	5.75	785	6.33	825	6.93	865	7.55	904	8.20	944	8.86
	15,000	829	8.84	850	9.19	888	9.88	924	10.57	958	11.27	991	11.99	1024	12.73
524J*30A	9,000	521	1.99	550	2.25	616	2.77	676	3.23	731	3.72	782	4.20	829	4.70
	10,500	596	3.16	623	3.40	672	3.89	720	4.40	767	4.94	814	5.50	859	6.05
	12,000	673	4.63	698	4.90	743	5.45	785	6.02	826	6.62	867	7.23	908	7.87
	13,500	751	6.51	773	6.82	815	7.44	853	8.06	890	8.71	927	9.38	963	10.07
	15,000	829	8.84	850	9.19	888	9.88	924	10.57	958	11.27	991	11.99	1024	12.73

See Legend and Notes on page 36.

**Table 10A - 524J Standard Fan Performance Data —
0.0-2.4 in. wg External Static Pressure — English (cont)**

UNIT	AIRFLOW (Cfm)	EXTERNAL STATIC PRESSURE (in. wg)											
		1.4		1.6		1.8		2.0		2.2		2.4	
		Rpm	Bhp	Rpm	Bhp	Rpm	Bhp	Rpm	Bhp	Rpm	Bhp	Rpm	Bhp
524J*25A 524J*25H	6,000	954	3.83	1005	4.27	1052	4.72	1098	5.22	1142	5.67	—	—
	7,000	990	4.74	1040	5.24	1090	5.80	1135	6.30	1176	6.84	—	—
	8,000	1028	5.79	1078	6.38	1130	7.00	1173	7.60	—	—	—	—
	9,000	1073	7.11	1120	7.72	1169	8.37	—	—	—	—	—	—
	10,000	1126	8.75	1166	9.37	—	—	—	—	—	—	—	—
524J*28A	7,500	831	4.41	870	5.10	913	5.90	950	6.88	985	7.70	—	—
	8,750	859	4.97	901	5.59	944	6.42	980	7.20	1020	8.10	—	—
	10,000	900	6.20	939	6.74	976	7.33	1013	8.00	1050	8.82	—	—
	11,250	941	7.73	980	8.32	1017	8.90	1052	9.51	1088	10.16	—	—
	12,500	984	9.53	1022	10.19	1058	10.84	1093	11.49	—	—	—	—
	15,000	1057	13.49	1090	14.28	—	—	—	—	—	—	—	—
524J*30A	9,000	866	5.20	899	5.85	950	6.65	989	7.38	1029	8.32	1077	9.74
	10,500	902	6.60	942	7.14	980	7.70	1016	8.31	1051	8.99	1085	9.77
	12,000	949	8.50	988	9.14	1026	9.76	1062	10.38	1095	11.01	—	—
	13,500	1000	10.78	1036	11.49	1073	12.21	—	—	—	—	—	—
	15,000	1057	13.49	1090	14.28	—	—	—	—	—	—	—	—

See Legend and Notes on page 36.

**Table 10B - 524J Standard Fan Performance Data —
0-600 kPa External Static Pressure — SI**

UNIT	AIRFLOW (L/s)	EXTERNAL STATIC PRESSURE (kPa)													
		0		50		100		150		200		250		300	
		r/s	kW	r/s	kW	r/s	kW	r/s	kW	r/s	kW	r/s	kW	r/s	kW
524J*25A 524J*25H	2830	8.86	0.94	9.48	1.04	10.65	1.26	11.84	1.53	13.01	1.85	14.10	2.19	15.08	2.53
	3300	10.14	1.44	10.69	1.56	11.70	1.81	12.71	2.08	13.73	2.41	14.74	2.77	15.71	3.15
	3780	11.43	2.11	11.93	2.25	12.84	2.52	13.71	2.81	14.60	3.14	15.49	3.51	16.39	3.91
	4250	12.74	2.96	13.19	3.12	14.02	3.43	14.81	3.74	15.59	4.08	16.37	4.45	17.17	4.85
	4720	14.05	4.01	14.47	4.19	15.23	4.54	15.96	4.88	16.66	5.24	17.36	5.62	18.07	6.03
524J*28A	3540	7.60	0.96	8.16	1.09	9.27	1.38	10.34	1.68	11.30	1.97	12.15	2.28	12.97	2.68
	4130	8.68	1.47	9.18	1.62	10.13	1.94	11.07	2.29	11.99	2.63	12.84	2.97	13.60	3.32
	4720	9.78	2.15	10.23	2.32	11.07	2.67	11.89	3.05	12.72	3.45	13.53	3.84	14.29	4.23
	5310	10.89	3.01	11.30	3.20	12.06	3.59	12.80	4.00	13.53	4.43	14.27	4.88	14.99	5.33
	5900	12.00	4.07	12.38	4.29	13.09	4.72	13.75	5.17	14.41	5.63	15.07	6.11	15.74	6.61
524J*30A	4250	8.68	1.48	9.17	1.68	10.27	2.07	11.27	2.41	12.19	2.77	13.03	3.13	13.81	3.50
	4960	9.93	2.35	10.38	2.53	11.21	2.90	11.99	3.28	12.78	3.68	13.56	4.10	14.32	4.51
	5660	11.21	3.45	11.63	3.66	12.38	4.07	13.08	4.49	13.76	4.93	14.45	5.39	15.14	5.87
	6370	12.51	4.85	12.89	5.08	13.58	5.54	14.22	6.01	14.83	6.49	15.44	6.99	16.05	7.51
	7080	13.82	6.59	14.17	6.85	14.81	7.36	15.40	7.88	15.97	8.40	16.52	8.94	17.06	9.49

See Legend and Notes on page 36.

**Table 10B - 524J Standard Fan Performance Data —
0-600 kPa External Static Pressure — SI (cont)**

UNIT	AIRFLOW (L/s)	EXTERNAL STATIC PRESSURE (kPa)											
		350		400		450		500		550		600	
		r/s	kW	r/s	kW	r/s	kW	r/s	kW	r/s	kW	r/s	kW
524J*25A 524J*25H	2830	15.90	2.86	16.75	3.18	17.53	3.52	18.30	3.89	19.03	4.23	—	—
	3300	16.50	3.53	17.33	3.91	18.17	4.32	18.92	4.70	19.60	5.10	—	—
	3780	17.13	4.32	17.97	4.76	18.83	5.22	19.55	5.67	—	—	—	—
	4250	17.88	5.30	18.67	5.76	19.48	6.24	—	—	—	—	—	—
	4720	18.77	6.52	19.43	6.99	—	—	—	—	—	—	—	—
524J*28A	3540	13.85	3.29	14.50	3.80	15.22	4.40	15.83	5.13	16.42	5.74	—	—
	4130	14.31	3.71	15.01	4.17	15.74	4.79	16.33	5.37	17.00	6.04	—	—
	4720	14.99	4.62	15.65	5.02	16.27	5.46	16.88	5.97	17.50	6.57	—	—
	5310	15.68	5.77	16.34	6.20	16.95	6.64	17.53	7.09	18.09	7.58	—	—
	5900	16.39	7.10	17.03	7.60	17.64	8.08	18.22	8.57	—	—	—	—
524J*30A	4250	14.43	3.88	14.98	4.36	15.84	4.96	16.48	5.50	17.16	6.21	17.96	7.26
	4960	15.04	4.92	15.71	5.32	16.33	5.74	16.93	6.20	17.51	6.70	18.09	7.29
	5660	15.81	6.34	16.47	6.81	17.10	7.28	17.69	7.74	18.26	8.21	—	—
	6370	16.66	8.04	17.27	8.57	17.88	9.10	—	—	—	—	—	—
	7080	17.61	10.06	18.16	10.64	—	—	—	—	—	—	—	—

See Legend and Notes on page 36.

524J

**Table 10C - 524J High-Capacity Fan Performance Data —
0.0-2.4 in. wg External Static Pressure — English**

UNIT	AIRFLOW (Cfm)	EXTERNAL STATIC PRESSURE (in. wg)													
		0.0		0.2		0.4		0.6		0.8		1.0		1.2	
		Rpm	Bhp	Rpm	Bhp	Rpm	Bhp	Rpm	Bhp	Rpm	Bhp	Rpm	Bhp	Rpm	Bhp
524J*25A 524J*25H	6,000	542	1.29	577	1.042	646	1.72	716	2.09	785	2.51	849	2.95	907	3.40
	7,000	620	1.99	652	2.15	711	2.48	771	2.85	831	3.28	890	3.76	947	4.27
	8,000	700	2.92	728	3.10	781	3.46	833	3.85	885	4.29	938	4.78	990	5.32
	9,000	781	4.10	806	4.30	854	4.71	900	5.13	946	5.58	993	6.08	1039	6.62
	10,000	862	5.56	885	5.79	929	6.24	971	6.70	1012	7.18	1054	7.69	1096	8.24
524J*28A	7,500	476	1.39	510	1.58	579	1.99	644	2.40	701	2.81	752	3.29	804	3.96
	8,750	545	2.14	574	2.35	633	2.81	691	3.29	747	3.77	797	4.25	842	4.76
	10,000	615	3.12	641	3.36	692	3.87	743	4.41	794	4.96	843	5.51	888	6.05
	11,250	685	4.37	709	4.64	754	5.20	800	5.79	845	6.40	891	7.02	935	7.64
	12,500	756	5.92	778	6.22	819	6.83	860	7.47	901	8.14	942	8.83	983	9.52
524J*30A	9,000	539	2.18	569	2.39	626	2.85	683	3.34	739	3.83	791	4.32	837	4.82
	10,500	620	3.37	646	3.62	695	4.13	744	4.68	793	5.25	842	5.83	888	6.41
	12,000	701	4.94	724	5.22	769	5.80	811	6.40	854	7.04	897	7.69	940	8.36
	13,500	783	6.95	804	7.27	844	7.91	883	8.57	920	9.26	958	9.97	996	10.71
	15,000	865	9.45	884	9.81	921	10.52	956	11.24	991	11.98	1025	12.75	1059	13.54

See Legend and Notes on page 36.

**Table 10C - 524J High-Capacity Fan Performance Data —
0.0-2.4 in. wg External Static Pressure — English (cont)**

UNIT	AIRFLOW (Cfm)	EXTERNAL STATIC PRESSURE (in. wg)											
		1.4		1.6		1.8		2.0		2.2		2.4	
		Rpm	Bhp	Rpm	Bhp	Rpm	Bhp	Rpm	Bhp	Rpm	Bhp	Rpm	Bhp
524J*25A 524J*25H	6,000	961	3.86	1011	4.31	1058	4.77	1104	5.24	1147	5.71	—	—
	7,000	1000	4.79	1050	5.32	1097	5.85	1142	6.38	1184	6.91	—	—
	8,000	1041	5.88	1090	6.47	1137	7.07	1181	7.67	—	—	—	—
	9,000	1086	7.21	1133	7.82	1178	8.47	—	—	—	—	—	—
	10,000	1138	8.83	1180	9.46	—	—	—	—	—	—	—	—
524J*28A	7,500	874	5.33	897	5.91	940	6.80	990	7.50	—	—	—	—
	8,750	886	5.36	930	6.13	982	7.32	1020	8.10	—	—	—	—
	10,000	930	6.60	969	7.20	1007	7.89	1045	8.71	—	—	—	—
	11,250	976	8.25	1014	8.86	1051	9.49	1086	10.17	—	—	—	—
	12,500	1023	10.20	1061	10.88	1097	11.56	—	—	—	—	—	—
524J*30A	9,000	881	5.37	923	6.03	967	6.89	1020	8.25	—	—	—	—
	10,500	930	6.97	970	7.55	1008	8.17	1045	8.86	—	—	—	—
	12,000	981	9.02	1021	9.67	1058	10.32	1094	10.97	—	—	—	—
	13,500	1035	11.45	1072	12.20	—	—	—	—	—	—	—	—
	15,000	1093	14.35	—	—	—	—	—	—	—	—	—	—

See Legend and Notes on page 36.

**Table 10D - 524J High-Capacity Fan Performance Data —
0-600 kPa External Static Pressure — SI**

UNIT	AIRFLOW (L/s)	EXTERNAL STATIC PRESSURE (kPa)													
		0		50		100		150		200		250		300	
		r/s	kW	r/s	kW	r/s	kW	r/s	kW	r/s	kW	r/s	kW	r/s	kW
524J*25A 524J*25H	2830	9.03	0.96	9.62	1.06	10.77	1.29	11.94	1.56	13.08	1087	14.15	2.20	15.12	2.54
	3330	10.34	1.48	10.86	1.60	11.85	1.85	12.84	2.12	13.85	2.45	14.84	2.80	15.78	3.18
	3780	11.67	2.17	12.14	2.31	13.02	2.58	13.88	2.87	14.75	3.20	15.63	3.56	16.50	3.96
	4250	13.01	3.05	13.44	3.21	14.23	3.51	15.00	3.82	15.77	4.16	16.54	4.53	17.32	4.94
	4720	14.36	4.15	14.75	4.32	15.48	4.66	16.18	4.99	16.87	5.35	17.56	5.73	18.26	6.14
524J*28A	3540	7.94	1.04	8.51	1.18	9.65	1.48	10.73	1.79	11.68	2.10	12.53	2.46	13.40	2.95
	4130	9.08	1.59	9.57	1.75	10.55	2.10	11.52	2.46	12.45	2.81	13.28	3.17	14.04	3.55
	4720	10.24	2.33	10.68	2.51	11.53	2.88	12.39	3.29	13.24	3.70	14.05	4.11	14.80	4.51
	5310	11.42	3.26	11.81	3.46	12.57	3.88	13.33	4.32	14.09	4.77	14.85	5.24	15.58	5.70
	5900	12.60	4.42	12.96	4.64	13.65	5.09	14.33	5.57	15.01	6.07	15.40	6.58	16.38	7.10
524J*30A	4250	8.99	1.62	9.49	1.78	10.44	2.12	11.39	2.49	12.32	2.86	13.18	3.22	13.95	3.59
	4960	10.33	2.51	10.77	2.70	11.59	3.08	12.40	3.49	13.22	3.92	14.03	4.35	14.79	4.78
	5660	11.68	3.68	12.07	3.90	12.81	4.33	13.52	4.77	14.23	5.25	14.95	5.74	15.66	6.23
	6370	13.04	5.18	13.40	5.42	14.07	5.90	14.71	6.39	15.34	6.90	15.97	7.44	16.61	7.98
	7080	14.42	7.05	14.74	7.31	15.36	7.84	15.94	8.38	16.51	8.93	17.08	9.51	17.65	10.10

See Legend and Notes on page 36.

**Table 10D - 524J High-Capacity Fan Performance Data —
0-600 kPa External Static Pressure — SI (cont)**

UNIT	AIRFLOW (L/s)	EXTERNAL STATIC PRESSURE (kPa)											
		350		400		450		500		550		600	
		r/s	kW	r/s	kW	r/s	kW	r/s	kW	r/s	kW	r/s	kW
524J*25A 524J*25H	2830	16.01	2.88	16.85	3.22	17.64	3.56	18.39	3.91	19.12	4.26	—	—
	3300	16.67	3.57	17.50	3.96	18.28	4.36	19.03	4.75	19.73	5.15	—	—
	3780	17.35	4.39	18.17	4.82	18.95	5.27	19.68	5.72	—	—	—	—
	4250	18.11	5.37	18.88	5.83	19.63	6.31	—	—	—	—	—	—
	4720	18.96	6.58	19.67	7.05	—	—	—	—	—	—	—	—
524J*28A	3540	14.57	3.97	14.95	4.41	15.67	5.07	16.50	5.59	—	—	—	—
	4130	14.76	3.99	15.51	4.57	16.36	5.46	17.00	6.04	—	—	—	—
	4720	15.49	4.92	16.15	5.37	16.78	5.88	17.42	6.50	—	—	—	—
	5310	16.26	6.15	16.91	6.61	17.51	7.08	18.10	7.58	—	—	—	—
	5900	17.04	7.61	17.68	8.11	18.28	8.62	—	—	—	—	—	—
524J*30A	4250	14.68	4.00	15.38	4.49	16.12	5.14	17.00	6.15	—	—	—	—
	4960	15.51	5.20	16.17	5.63	16.80	6.09	17.41	6.61	—	—	—	—
	5660	16.35	6.72	17.01	7.21	17.64	7.69	18.23	8.18	—	—	—	—
	6370	17.24	8.54	17.87	9.10	—	—	—	—	—	—	—	—
	7080	18.22	10.70	—	—	—	—	—	—	—	—	—	—

See Legend and Notes on page 36.

524J

Legend and Notes for Tables 10A and 10C

LEGEND

Bhp – Brake Horsepower Input to Fan

ESP – External Static Pressure

NOTES:

1. Maximum allowable fan speed for size 25 units is 1200 rpm . Maximum allowable fan speed for size 28 and 30 units is 1100 rpm.
2. Fan performance is based on deductions for wet coil, clean 2-in. filters, and unit casing. See table at right for factory-supplied filter pressure drop.
3. Refer to fan motor and drive tables for additional data.

FACTORY-SUPPLIED PRESSURE DROP — ENGLISH

UNIT	AIRFLOW (Cfm)	PRESSURE DROP (in. wg)
524J*25A 524J*25H	6,000	0.12
	8,000	0.19
	10,000	0.26
524J*28A	7,500	0.15
	10,000	0.22
	12,500	0.30
524J*30A	9,000	0.19
	12,000	0.29
	15,000	0.40

Legend and Notes for Tables 10B and 10D

LEGEND

ESP – External Static Pressure

NOTES:

1. Maximum allowable fan speed for size 25 units is 20 r/s. Maximum allowable fan speed for size 28 and 30 units is 18.3 r/s.
2. Fan performance is based on deductions for wet coil, clean 51 –mm filters, and unit casing. See table at right for factory-supplied filter pressure drop.
3. Refer to fan motor and drive tables for additional data.

FACTORY-SUPPLIED PRESSURE DROP — SI

UNIT	AIRFLOW (L/s)	PRESSURE DROP (Pa)
524J*25A 524J*25H	2900	32
	3800	47
	4700	64
524J*28A	3500	36
	4700	55
	5900	76
524J*30A	4250	47
	5650	71
	7050	98

START-UP CHECKLIST

(SPLIT SYSTEMS WITH 524J UNITS)

I. PRELIMINARY INFORMATION

OUTDOOR: MODEL NO. _____ INDOOR: MODEL NO. _____
SERIAL NO. _____ SERIAL NO. _____
ADDITIONAL ACCESSORIES _____

II. PRE-START-UP

OUTDOOR UNIT

IS THERE ANY SHIPPING DAMAGE? (Y/N) _____
IF SO, WHERE: _____

WILL THIS DAMAGE PREVENT UNIT START-UP? (Y/N) _____
CHECK POWER SUPPLY. DOES IT AGREE WITH UNIT? (Y/N) _____
HAS THE GROUND WIRE BEEN CONNECTED? (Y/N) _____
HAS THE CIRCUIT PROTECTION BEEN SIZED AND INSTALLED PROPERLY? (Y/N) _____
ARE THE POWER WIRES TO THE UNIT SIZED AND INSTALLED PROPERLY? (Y/N) _____
HAVE COMPRESSOR HOLDDOWN BOLTS BEEN LOOSENED? (Y/N) _____

CONTROLS

ARE THERMOSTAT(S) & INDOOR FAN CONTROL WIRING CONNECTIONS MADE & CHECKED? (Y/N) _____
ARE ALL WIRING TERMINALS (including main power supply) TIGHT? (Y/N) _____
HAVE OUTDOOR UNIT CRANKCASE HEATERS BEEN ENERGIZED FOR 24 HOURS? (Y/N) _____

INDOOR UNIT

HAS WATER BEEN PLACED IN DRAIN PAN TO CONFIRM PROPER DRAINAGE? (Y/N) _____
ARE PROPER AIR FILTERS IN PLACE? (Y/N) _____
HAVE FAN AND MOTOR PULLEYS BEEN CHECKED FOR PROPER ALIGNMENT? (Y/N) _____
DO THE FAN BELTS HAVE PROPER TENSION? (Y/N) _____

PIPING

HAS FOAM SHIPPING BLOCK BEEN REMOVED FROM THE TXV (Thermostatic Expansion Valve)? (Y/N) _____
ARE LIQUID LINE SOLENOID VALVES LOCATED AT THE INDOOR UNIT (524J***A) OR OUTDOOR UNIT (524J*25H) COILS AS REQUIRED? (Y/N) _____
HAVE LEAK CHECKS BEEN MADE AT COMPRESSORS, CONDENSERS, INDOOR COILS, TXVs (Thermostatic Expansion Valves) SOLENOID VALVES, FILTER DRIERS, AND FUSIBLE PLUGS WITH A LEAK DETECTOR? (Y/N) _____
LOCATE, REPAIR, AND REPORT ANY LEAKS _____
HAVE ALL COMPRESSOR SERVICE VALVES BEEN FULLY OPENED (BACKSEATED) (Y/N) _____
ARE THE COMPRESSOR OIL SIGHT GLASSES SHOWING CORRECT LEVELS? (Y/N) _____

CHECK VOLTAGE IMBALANCE

LINE-TO-LINE VOLTS: AB _____ V AC _____ V BC _____ V

(AB + AC + BC)/3 = AVERAGE VOLTAGE = _____ V

MAXIMUM DEVIATION FROM AVERAGE VOLTAGE = _____ V

VOLTAGE IMBALANCE = 100 X (MAX DEVIATION)/(AVERAGE VOLTAGE) = _____

IF OVER 2% VOLTAGE IMBALANCE, DO NOT ATTEMPT TO START SYSTEM!
CALL LOCAL POWER COMPANY FOR ASSISTANCE.

III. START-UP

CHECK INDOOR FAN MOTOR SPEED AND RECORD.

AFTER AT LEAST 10 MINUTES RUNNING TIME, RECORD THE FOLLOWING MEASUREMENTS:

524J

	COMP A1	COMP B1
OIL PRESSURE	_____	_____
SUCTION PRESSURE	_____	_____
SUCTION LINE TEMP	_____	_____
DISCHARGE PRESSURE	_____	_____
DISCHARGE LINE TEMP	_____	_____
ENTERING OUTDOOR UNIT AIR TEMP	_____	_____
LEAVING OUTDOOR UNIT AIR TEMP	_____	_____
INDOOR UNIT ENTERING AIR DB TEMP	_____	_____
INDOOR UNIT ENTERING AIR WB TEMP	_____	_____
INDOOR UNIT LEAVING AIR DB TEMP	_____	_____
INDOOR UNIT LEAVING AIR WB TEMP	_____	_____
COMPRESSOR AMPS (L1/L2/L3)	____/____/____	____/____/____

CHECK THE COMPRESSOR OIL LEVEL SIGHT GLASSES, ARE THE SIGHT GLASSES SHOWING OIL LEVEL AT 1/8 to 1/3 FULL? (Y/N) _____

NOTES:
