

Owner's Manual

Model:

M2OF-18HFN1-M

M3OF-27HFN1-M

M4OF-36HFN1-M

M5OF-48HFN1-M

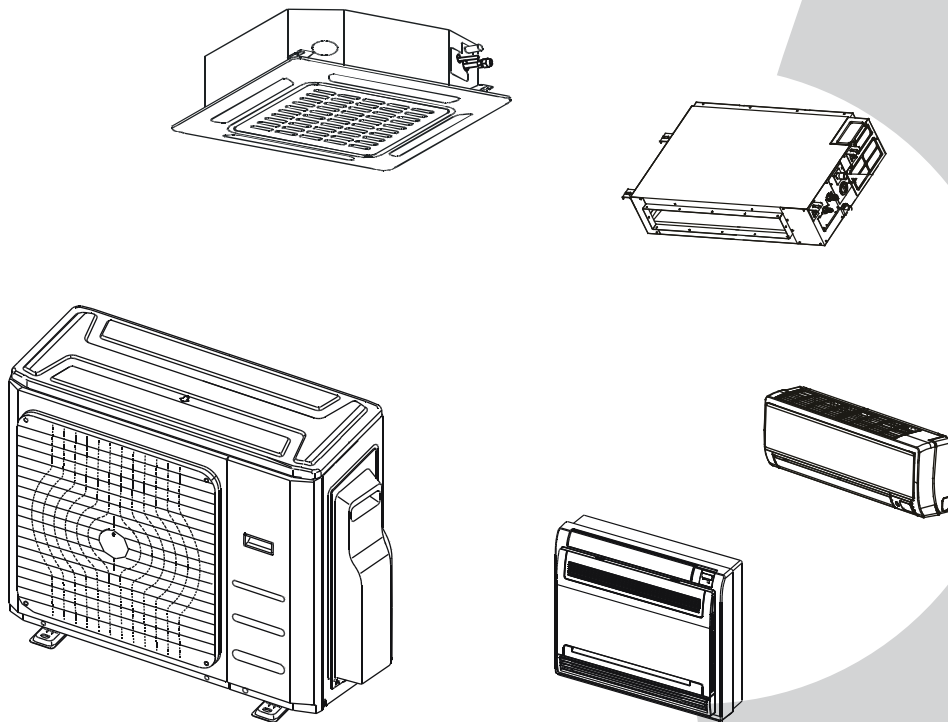

IMPORTANT NOTE:

- Read this manual carefully before installing or operating your new air conditioning unit. Make sure to save this manual for future reference.
- This manual is only describes the outdoor unit. When using the indoor unit, refer to the user's manual of the indoor unit.

Table of Contents

- 1 Safety Precautions 04
- 2 Unit Parts and Major Functions 05
- 3 Manual Operation and Maintenance 09

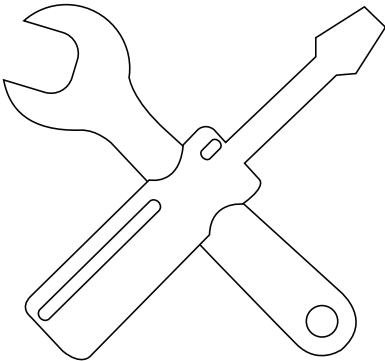
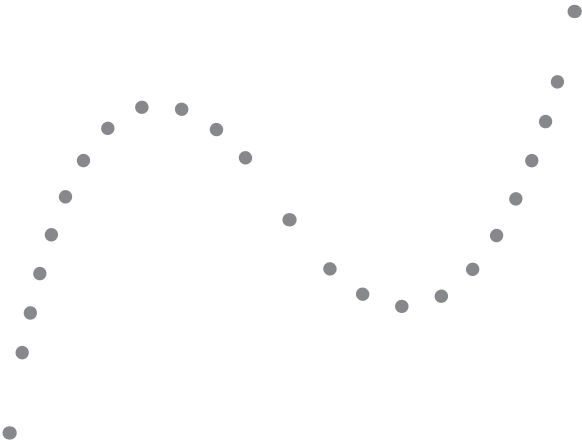

4 Troubleshooting 10

 a. Common Problems 10

 b. Troubleshooting Tips 11

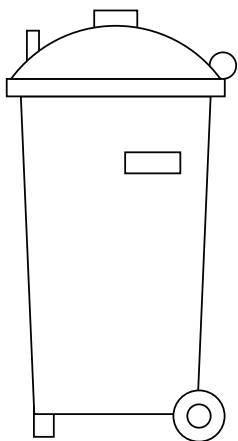
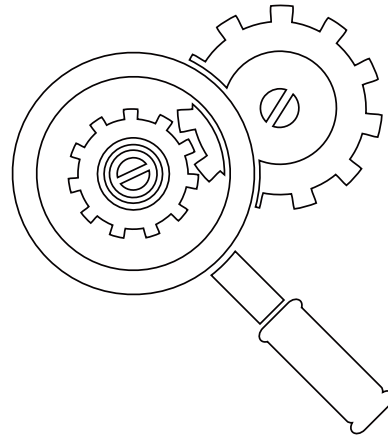

5 European Disposal Guidelines 12

Safety Precautions

1

Thank you for purchasing this air conditioner. This manual will provide you with information on how to operate, maintain, and troubleshoot your air conditioner. Following the instructions will ensure the proper function and extended lifespan of your unit.

Please pay attention to the following signs:



WARNING

Failure to observe a warning may result in death. The appliance must be installed in accordance with national regulations.



CAUTION

Failure to observe a caution may result in injury or equipment damage.

WARNING

- Ask an authorized dealer to install this air conditioner. Inappropriate installation may cause water leakage, electric shock, or fire.
- The warranty will be voided if the unit is not installed by professionals.
- If abnormal situation arises (like burning smell), turn off the power supply and call your dealer for instructions to avoid electric shock, fire, or injury.
- DO NOT let the indoor unit or the remote control get wet. It may cause electric shock or fire.
- DO NOT insert fingers, rods, or other objects into the air inlet or outlet. This may cause injury, since the fan may be rotating at high speeds.
- DO NOT use a flammable spray, such as hairspray, lacquer, or paint, near the unit. This may cause fire or combustion.

CAUTION

- DO NOT touch the air outlet while the swing flap is in motion. Fingers might get caught or the unit may break down.
- DO NOT inspect the unit by yourself. Ask an authorized dealer to perform the inspection.
- To prevent product deterioration, do not use the air conditioner for preservation purposes (storage of food, plants, animals, works of art, etc.).
- DO NOT touch the evaporator coils inside the indoor unit. The evaporator coils are sharp and may cause injury.

- DO NOT operate the air conditioner with wet hands. It may cause electric shock.
- DO NOT place items that might be affected by moisture damage under the indoor unit. Condensation can occur at a relative humidity of 80%.
- DO NOT expose heat-producing appliances to cold air or place them under the indoor unit. This may cause incomplete combustion or deformation of the unit due to the heat.
- After long periods of usage, check the indoor unit to see if anything is damaged. If the indoor unit is damaged, it may fall and cause injury.
- If the air conditioner is used with other heating devices, thoroughly ventilate the room to avoid oxygen deficiency.
- DO NOT climb onto or place objects on top of the outdoor unit.
- DO NOT operate the air conditioner when using fumigant insecticides. The chemicals may become layered with the unit and endanger those who are hypersensitive to chemicals.
- DO NOT let children play with the air conditioner.
- The air conditioner can be used by children aged 8 years and older and people with reduced physical, sensory, or mental capabilities, or lack of experience and knowledge, if they have been given instruction on how to properly and safely operate the system.
- DO NOT operate the air conditioner in a wet room (e.g. bathroom or laundry room). This can cause electric shock and cause the product to deteriorate.

Unit Parts

Wall-mounted type

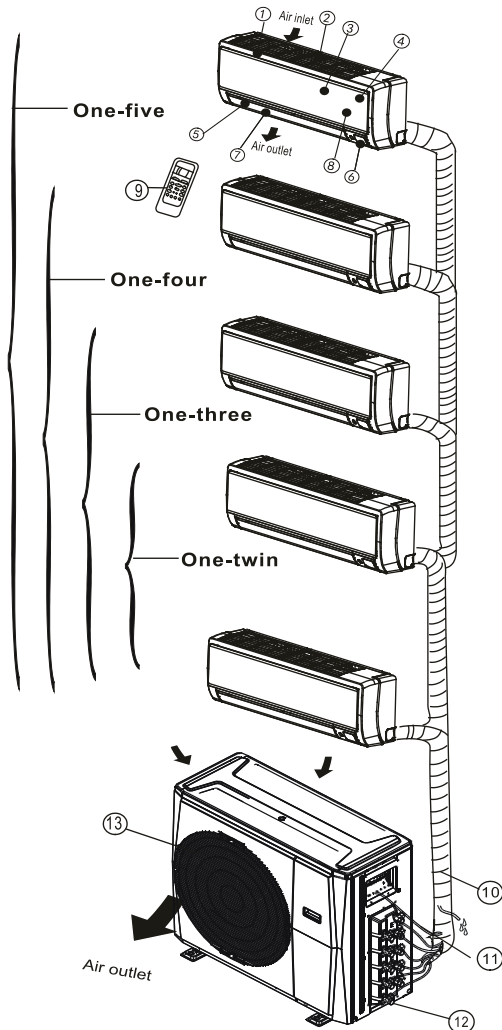

Fig. 2.1

Indoor unit

1. Panel frame
2. Rear air intake grille
3. Front panel
4. Air purifying filter & air filter (rear)
5. Horizontal louver
6. LCD display window
7. Vertical louver
8. Manual control button (behind)
9. Remote controller holder

Outdoor unit

10. Drain hose and refrigerant connecting pipe
11. Connective cable
12. Stop valve
13. Fan hood

Duct / Ceiling type

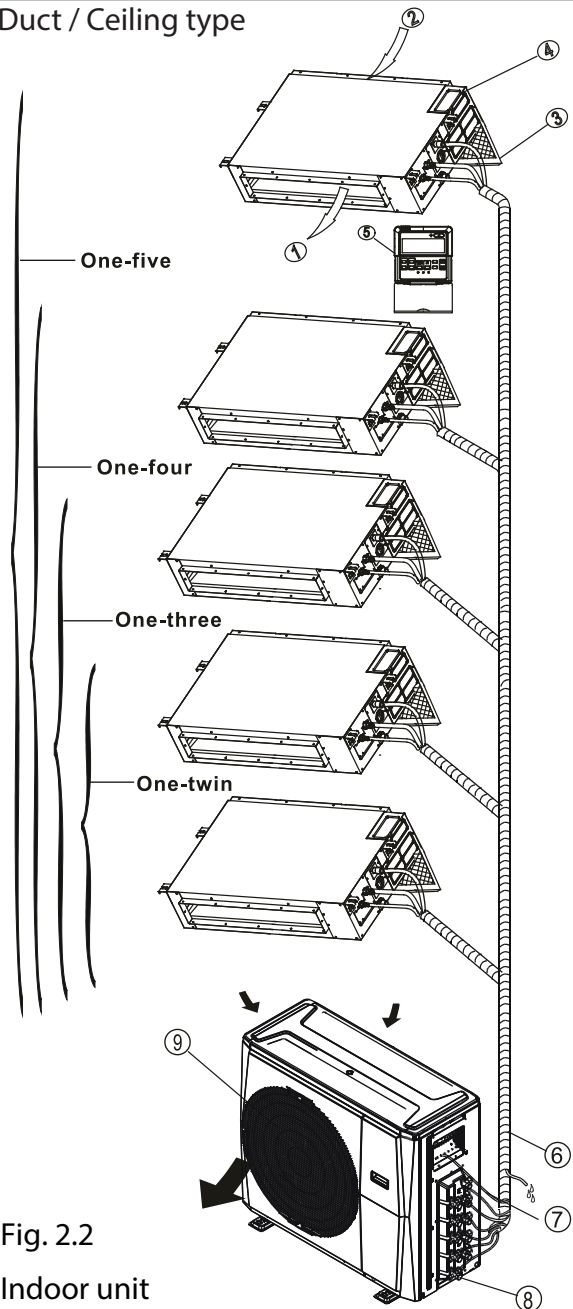

Fig. 2.2

Indoor unit

1. Air outlet
2. Air inlet
3. Air filter
4. Electric control cabinet
5. Wire controller

Outdoor unit

6. Drain hose and refrigerant connecting pipe
7. Connective cable
8. Stop valve
9. Fan hood

Floor and standing type (console)

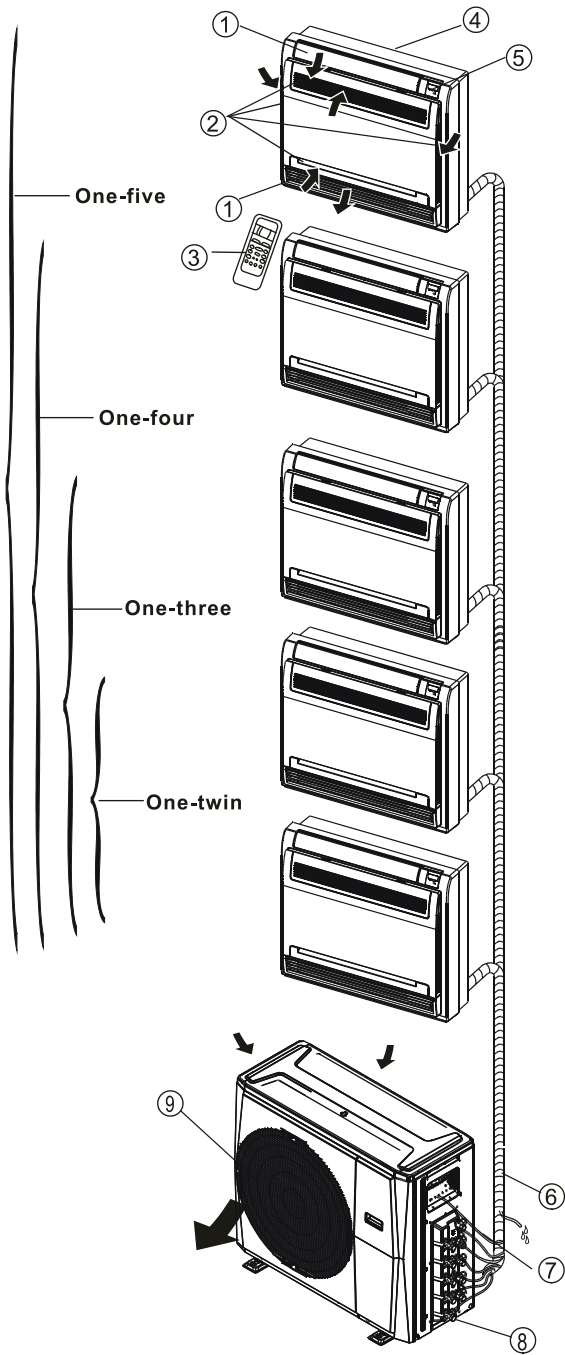

Fig. 2.3

Indoor unit

1. Airflow louver (at air outlet)
2. Air inlet (with air filter in it)
3. Remote controller
4. Installation part
5. Display panel

Outdoor unit

6. Drain hose, refrigerant connecting pipe
7. Connective cable
8. Stop valve
9. Fan hood

Compact four-way cassette-type

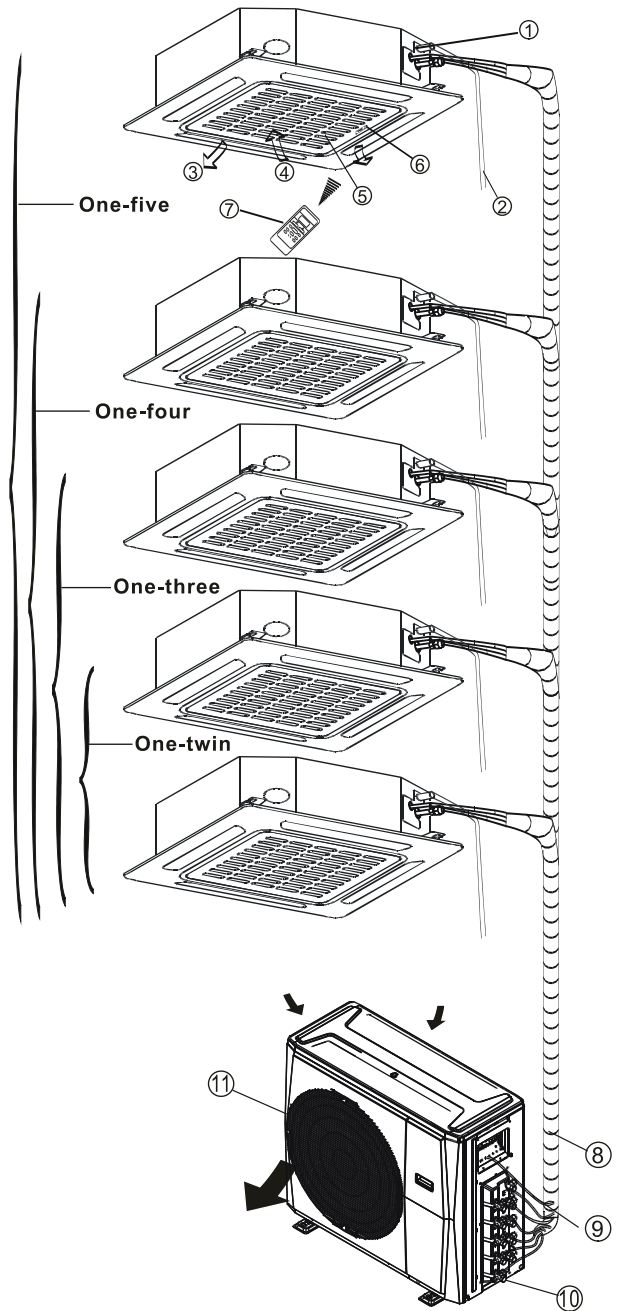

Fig. 2.4

Indoor unit

1. Drain pump (drain water from indoor unit)
2. Drain hose
3. Air outlet
4. Air inlet
5. Air-in grill
6. Display panel
7. Remote controller

Outdoor unit

8. Refrigerant connecting pipe
9. Connective cable
10. Stop valve
11. Fan hood

NOTE: For multi-split-type air conditioners, one outdoor unit can match different types of indoor units. Therefore, all the pictures in this manual are for explanation only. Your air conditioner may be slightly different. The actual shape shall prevail.

The following pages introduce several kinds of indoor units matching with the outdoor units.

Operating Conditions

Use the system in the following temperature for safe and effective operation. If the air conditioner is used outside of the following conditions, it may malfunction or be less efficient.

	COOL Mode	HEAT mode	DRY mode
Indoor Temperature	17-32°C (62-90°F)	0-30°C (32-86°F)	17-32°C (62-90°F)
Outdoor Temperature	0-50°C (32-122°F)	-15-24°C (5-76°F)	0-50°C (32-122°F)
	-15-50°C (5-122°F) (low temperature cooling models)		

Features

Protection of the air conditioner

Compressor protection

- The compressor can't restart for 3 minutes after it stops.

Anti-cold air (Cooling and heating models only)

- The unit is designed not to blow cold air on HEAT mode, when the indoor heat exchanger is in one of the following three situations and the set temperature has not been reached.
 - A) When heating has just starting.
 - B) Defrosting.
 - C) Low temperature heating.

- The indoor or outdoor fan stops running when defrosting (Cooling and heating models only).

Defrosting (Cooling and heating models only)

- Frost may be generated on the outdoor unit during heat cycle when outdoor temperature is low and humidity is high, resulting in lower heating efficiency of the air conditioner.
- During this condition, air conditioner will stop heating operation and start defrosting automatically.
- The time to defrost may vary between 4 to 10 minutes according to the outdoor temperature and the amount of frost buildup on the outdoor unit.

Auto-Restart (some models)

In case of power failure, the system will immediately stop. When power returns, the Operation light on the indoor unit will flash. To restart the unit, press the ON/OFF button on the remote control. If the system has an auto-restart function, the unit will restart using the same settings.

A white mist coming out from the indoor unit

- A white mist may generate due to a large temperature difference between air inlet and air outlet on COOL mode in an indoor environment that has a high relative humidity.
- A white mist may generate due to moisture generated from defrosting process when the air conditioner restarts in HEAT mode after defrosting.

Low noise of the air conditioner

- You may hear a low hissing sound when the compressor is running or has just stopped running. This sound is the refrigerant flowing or coming to a stop.
- You can also hear a low "squeak" sound when the compressor is running or has just stopped running. This is caused by heat expansion and cold contraction of the plastic parts in the unit when the temperature is changing.
- A noise may be heard due to louver restoring to its original position when power is first turned on.

Dust is blown out from the indoor unit.

This is a normal condition when the air conditioner has not been used for a long time or during first use of the unit.

A peculiar smell comes out from the indoor unit.

This is caused by the indoor unit giving off smells permeated from building materials, furniture, or smoke.

The air conditioner turns to FAN only mode from COOL or HEAT (for cooling and heating models only) mode.

When indoor temperature reaches the temperature setting on air conditioner, the compressor will stop automatically, and the air conditioner will turn to FAN only mode. The compressor will start again when the indoor temperature rises on COOL mode or falls on HEAT mode (for cooling and heating models only) to the set point.

Dripping water may accumulate on the surface of the indoor unit when cooling in areas with relatively high humidity (relative humidity higher than 80%). Adjust the horizontal louver to the maximum air outlet position and select HIGH fan speed.

Heating mode (for cooling and heating models only)

The air conditioner draws in heat from the outdoor unit and releases it via the indoor unit during heating operation. When the outdoor temperature falls, heat drawn in by the air conditioner decreases accordingly. At the same time, heat loading of the air conditioner increases due to larger difference between indoor and outdoor temperature. If a comfortable temperature can't be achieved by the air conditioner, we suggest you use a supplementary heating device.

Lightning or a car wireless telephone operating nearby may cause the unit to malfunction. Disconnect the unit from the power source and then reconnect it. Push the ON/OFF button on the remote controller to restart operation.

Energy-Saving Tips

- **DO NOT** set the unit to excessive temperature levels.
- While cooling, close the curtains to keep out direct sunlight.
- Doors and windows should be kept closed to keep cool or warm air in the room.
- **DO NOT** place objects near the air inlet and outlet of the unit. This will reduce the efficiency of the unit.
- Set a timer and use the built-in SLEEP/ECONOMY mode if applicable.
- If you don't plan to use the unit for a long time, remove the batteries from the remote control.
- Clean the air filter every two weeks. A dirty filter can reduce cooling or heating efficiency.
- Adjust louvers properly and avoid direct airflow.

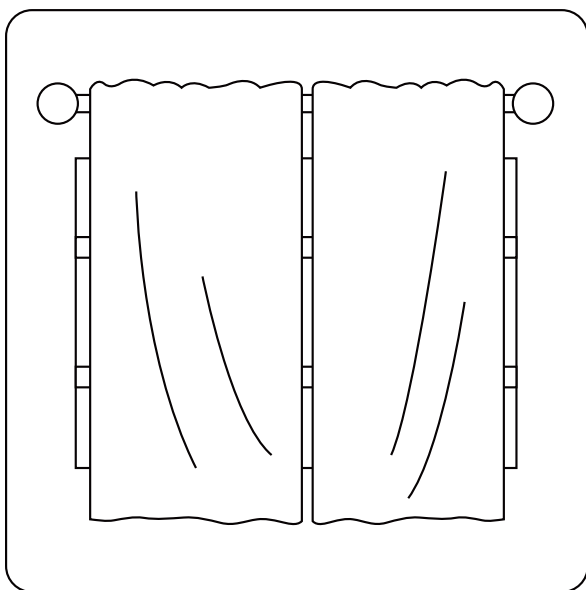

Closing the curtains while heating also helps keep the heat in

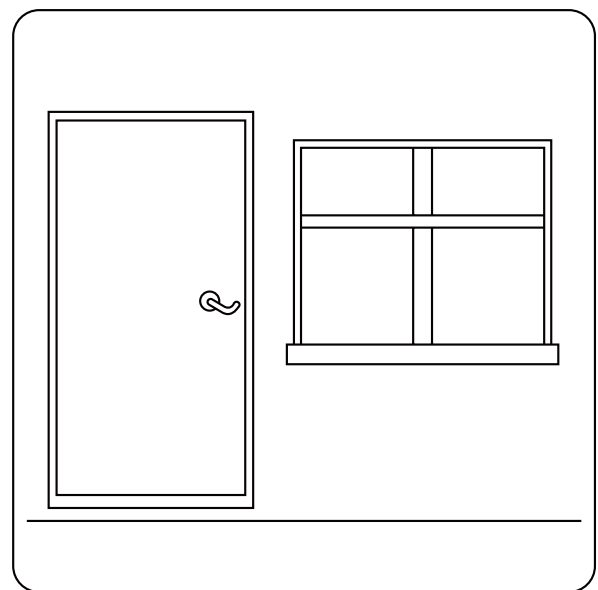

Doors and windows should be kept closed

Operation mode selection

While simultaneously operating two indoor units or more, make sure the operation modes do not conflict with each other. The heat mode claims precedence over all other modes. If the unit initially started operates under heat mode, the other units should operate under heat mode only. For example: If the unit initially started operates under cool (or fan) mode, the other units can operate under any mode except heat. If one of the units select heat mode, the other operating units will stop operation and display "---" (for the units with display window only), or the Auto and Operation indication light will flash rapidly, the Defrost indication light will turn off, the Timer indication light will remain on (for the units without display window), the Defrost and Alarm indication lights (if applicable) will illuminate or, the Operation indication light will flash rapidly and the Timer indication light will turn off (for the floor and standing types).

Maintenance

If you plan to idle the unit for a long time, perform the following:

1. Clean the indoor unit and air filter.
2. Select FAN only mode, let the indoor fan run for a while to dry the inside of the unit.
3. Disconnect the power supply and remove battery from the remote control.
4. Check components of the outdoor unit periodically. Contact a local dealer or a customer service centre if the unit requires servicing.

NOTE: Before you clean the air conditioner, be sure to switch the unit off and disconnect the power supply plug.

Optimal operation

To achieve optimal performance, please note the following:

- Adjust the airflow direction correctly so that it is not directed at people.
- Adjust the temperature to achieve the highest comfort level. Do not adjust the unit to excessive temperature levels.
- Close doors and windows on COOL or HEAT modes, or performance may be reduced.
- Use TIMER ON button on the remote controller to select a time you want to start your air conditioner.
- Do not put any object near air inlet or air outlet, as the efficiency of the air conditioner may be reduced and the air conditioner may stop running.
- Clean the air filter periodically, otherwise cooling or heating performance may be reduced.
- Do not operate unit with horizontal louver in closed position.

Suggestion: For the unit that adopts an Electric Heater, when the outside ambient temperature is below 0°C (32°F), we strongly recommend keeping the machine plugged in to guarantee it runs smoothly.

When the air conditioner is to be used again:

- Use a dry cloth to wipe off the dust accumulated on rear air intake grille, in order to avoid the dust blowing out from the indoor unit.
- Check that the wiring is not broken off or disconnected.
- Check that the air filter is installed.
- Check if the air outlet or inlet isn't blocked after the air conditioner has not been used for a long time.

! CAUTIONS

If one of the following conditions occurs, switch off the power supply immediately and contact your dealer for further assistance.

- The operation light continues to flash rapidly after the unit has been restarted.
- The remote control buttons do not work.
- The unit continually trips fuses or circuit breakers.
- A foreign object or water enters the air conditioner.
- The indoor unit leaks.

Common Problems

The following symptoms are not a malfunction and in most situations will not require repairs.

Problem	Possible Causes
Unit does not turn on when pressing ON/OFF button	The unit has a 3-minute protection feature that prevents the unit from overloading. The unit cannot be restarted within three minutes of being turned off.
	Cooling and Heating Models: If the Operation light and PRE-DEF (Pre-heating/Defrost) indicators light up, the outdoor temperature is too cold and the unit's anti-cold wind is activated in order to defrost the unit.
	In Cooling-only Models: If the "Fan Only" indicator lights up, the outdoor temperature is too cold and the unit's anti-freeze protection is activated in order to defrost the unit.
The unit changes from COOL mode to FAN mode	The unit changes its setting to prevent frost from forming. Once the temperature increases, the unit will start operating again.
	The set temperature has been reached, at which point the unit turns off the compressor. The unit will resume operating when the temperature fluctuates again.
The indoor unit emits white mist	In humid regions, a large temperature difference between the room's air and the conditioned air can cause white mist.
Both the indoor and outdoor units emit white mist	When the unit restarts in HEAT mode after defrosting, white mist may be emitted due to moisture generated from the defrosting process.
The indoor unit makes noises	A squeaking sound is heard when the system is OFF or in COOL mode. The noise is also heard when the drain pump (optional) is in operation.
	A squeaking sound may occur after running the unit in HEAT mode due to expansion and contraction of the unit's plastic parts.
Both the indoor unit and outdoor unit make noises	A low hissing sound may occur during operation. This is normal and is caused by refrigerant gas flowing through the indoor and outdoor units.
	A low hissing sound may be heard when the system starts, has just stopped running, or is defrosting. This noise is normal and is caused by the refrigerant gas stopping or changing direction.
The outdoor unit makes noises	The unit will make different sounds based on its current operating mode.

Problem	Possible Causes
Dust is emitted from either the indoor or outdoor unit	The unit may accumulate dust during extended periods of non-use, which will be emitted when the unit is turned on. This can be mitigated by covering the unit during long periods of inactivity.
The unit emits a bad odor	The unit may absorb odors from the environment (such as furniture, cooking, cigarettes, etc.) which will be emitted during operations.
	The unit's filters have become moldy and should be cleaned.
The fan of the outdoor unit does not operate	During operation, the fan speed is controlled to optimize product operation.

Troubleshooting Tips

When troubles occur, please check the following points before contacting a repair company.

Problem	Possible Causes	Solution
The unit is not working	Power failure	Wait for the power to be restored
	The power switch is off	Turn on the power
	The fuse is burned out	Replace the fuse
	Remote control batteries are dead	Replace the remote control batteries
	The unit's 3-minute protection has been activated	Wait three minutes after restarting the unit
Poor cooling performance	Temperature setting may be higher than the ambient room temperature	Lower the temperature setting
	The heat exchanger on the indoor or outdoor unit is dirty	Clean the affected heat exchanger
	The air filter is dirty	Remove the filter and clean it according to instructions
	The air inlet or outlet of either unit is blocked	Turn the unit off, remove the obstruction, and turn it back on
	Doors and windows are open	Make sure that all doors and windows are closed while operating the unit
	Excessive heat is generated by sunlight	Close windows and curtains during periods of high heat or bright sunshine
	Low refrigerant due to leak or long-term use	Check for leaks, reseal if necessary, and top off refrigerant
The unit starts and stops frequently	There's too much or too little refrigerant in the system	Check for leaks and recharge the system with refrigerant
	There is air, incompressible gas, or foreign material in the refrigeration system.	Evacuate and recharge the system with refrigerant
	System circuit is blocked	Determine which circuit is blocked and replace the malfunctioning piece of equipment
	The compressor is broken	Replace the compressor
	The voltage is too high or too low	Install a manostat to regulate the voltage
Poor heating performance	The outdoor temperature is lower than 7°C (44.5°F)	Check for leaks and recharge the system with refrigerant
	Cold air is entering through doors and windows	Make sure that all doors and windows are closed during use
	Low refrigerant due to leak or long-term use	Check for leaks, reseal if necessary, and top off refrigerant

Users in Europe may be required to properly dispose of this unit. This appliance contains refrigerant and other potentially hazardous materials. When disposing of this appliance, the law requires special collection and treatment. DO NOT dispose of this product as household waste or unsorted municipal waste.

When disposing of this appliance, you have the following options:

- Dispose of the appliance at designated municipal electronic waste collection facility.
- When buying a new appliance, the retailer will take back the old appliance free of charge.
- The manufacturer will also take back the old appliance free of charge.
- Sell the appliance to certified scrap metal dealers.

NOTE: Disposing of this appliance in the forest or other natural surroundings endangers your health and is bad for the environment. Hazardous substances may leak into the groundwater and enter the food chain.

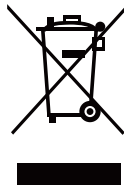

QSBPTYU-041AEN

The design and specifications are subject to change without prior notice for product improvement. Consult with the sales agency or manufacturer for details.

16122300A05346