

50ES-A

Comfort™ 13 SEER Single-Packaged Air Conditioner
System With Puron® (R-410A) Refrigerant
Three Phase
2 1/2-5 Nominal Tons (Sizes 30-60)



Product Data

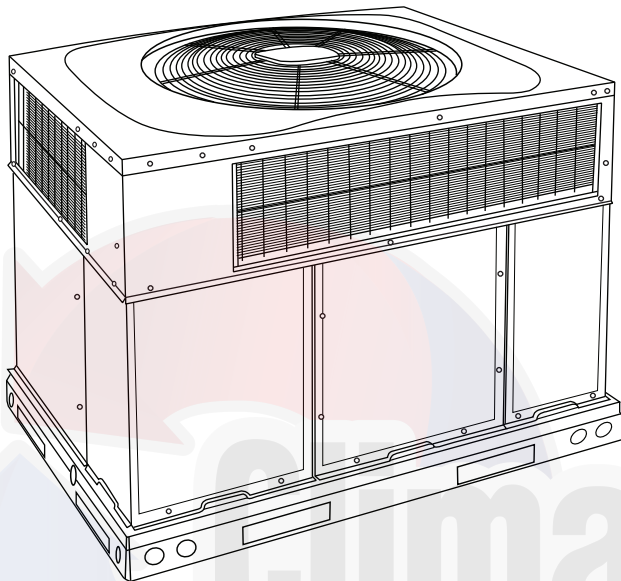

Fig. 1 - Unit 50ES-A

A09034

Single-Packaged Products with Energy-Saving Features and Puron® refrigerant.

- Up to 13.5 SEER
- Factory-Installed TXV
- ECM Motor-Standard
- Low Sound Levels

FEATURES/BENEFITS

One-piece cooling unit with optional electric heater, low sound levels, easy installation, low maintenance, and dependable performance.

Puron Environmentally Sound Refrigerant is Carrier's unique refrigerant designed to help protect the environment. Puron is an HFC refrigerant which does not contain chlorine that can harm the ozone layer. Puron refrigerant is in service in millions of systems, proving highly reliable, environmentally sound performance.

Easy Installation

Factory-assembled package is a compact, fully self-contained, electric cooling unit that is prewired, pre-piped, and pre-charged for minimum installation expense. These units are available in a variety of standard cooling sizes with voltage options to meet residential and light commercial requirements. Units are lightweight and install easily on a rooftop or at ground level. The high tech composite base eliminates rust problems associated with ground level applications.

Innovative Unit Base Design

On the inside a high-tech composite material will not rust and incorporates a sloped drain pan which improves drainage and helps inhibit mold, algae and bacterial growth. On the outside metal base rails provide added stability as well as easier handling and rigging.

Convertible duct configuration

Unit is designed for use in either downflow or horizontal applications. Each unit is converted from horizontal to downflow and includes horizontal duct covers. Downflow operation is provided in the field to allow vertical ductwork connections. The basepan seals on the bottom openings to ensure a positive seal in the vertical airflow mode.

Efficient operation High-efficiency design offers SEER (Seasonal Energy Efficiency Ratios) of up to 13.5. (See page 4.)

Durable, dependable components

Scroll Compressors are designed for high efficiency. Each compressor is hermetically sealed against contamination to help promote longer life and dependable operation. Each compressor also has vibration isolation to provide quieter operation. All compressors have internal high pressure and overcurrent protection.

ECM Motor is standard on all models.

Direct-drive PSC (Permanent Split Capacitor) condenser-fan motors are designed to help reduce energy consumption and provide for cooling operation down to 40°F (4.4°C) outdoor temperature. Motormaster® II low ambient kit is available as a field-installed accessory.

Thermostatic Expansion Valve - A hard shutoff, balance port TXV maintains a constant superheat at the evaporator exit (cooling cycle) resulting in higher overall system efficiency.

Refrigerant system is designed to provide dependability. Liquid filter driers are used to promote clean, unrestricted operation. Each unit leaves the factory with a full refrigerant charge. Refrigerant service connections make checking operating pressures easier.

High and Low Pressure Switches provide added reliability for the compressor.

Indoor and Outdoor coils are computer-designed for optimum heat transfer and efficiency. The indoor coil is fabricated from copper tube and aluminum fins and is located inside the unit for protection against damage. The outdoor coil is internally mounted on the top tier of the unit.

Low sound ratings ensure a quiet indoor and outdoor environment with sound ratings as low as 75dBA. (See Page 4.)

Easy to service cabinets provide easy 3-panel accessibility to serviceable components during maintenance and installation. The basepan with integrated drain pan provides easy ground level installation with a mounting pad. A nesting feature ensures a positive basepan to roof curb seal when the unit is roof mounted. A convenient 3/4-in. (19.1 mm) wide perimeter flange makes frame mounting on a rooftop easy.

Standard horizontal metal duct covers with insulation come with the unit and cover the horizontal duct openings. These can be left in place if the units are converted to downflow.

Cabinets are constructed of heavyduty, phosphated, zinc-coated prepainted steel capable of withstanding 500 hours in salt spray. Interior surfaces of the evaporator/heat exchanger compartment are insulated with cleanable semi-rigid insulation board, which keeps the conditioned air from being affected by the outdoor ambient temperature and provides improved indoor air quality. (Conforms to American Society of Heating, Refrigeration and Air Conditioning Engineers No. 62P.) The sloped drain pan minimizes standing water in the drain. An external drain is provided.

TABLE OF CONTENTS

FEATURES/BENEFITS	1
MODEL NUMBER NOMENCLATURE	3
AHRI CAPACITIES	4
PHYSICAL DATA	5
OPTIONS AND ACCESSORIES	6
BASE UNIT DIMENSIONS	8-9
ACCESSORY ROOF CURB	10
SELECTION PROCEDURE	11
PERFORMANCE DATA	12-21
TYPICAL PIPING AND WIRING	24
APPLICATION DATA	25
ELECTRICAL DATA	26-NO TAG
TYPICAL WIRING SCHEMATICS	28-31
CONTROLS	32
GUIDE SPECIFICATIONS	33

50ES--A



MODEL NUMBER NOMENCLATURE

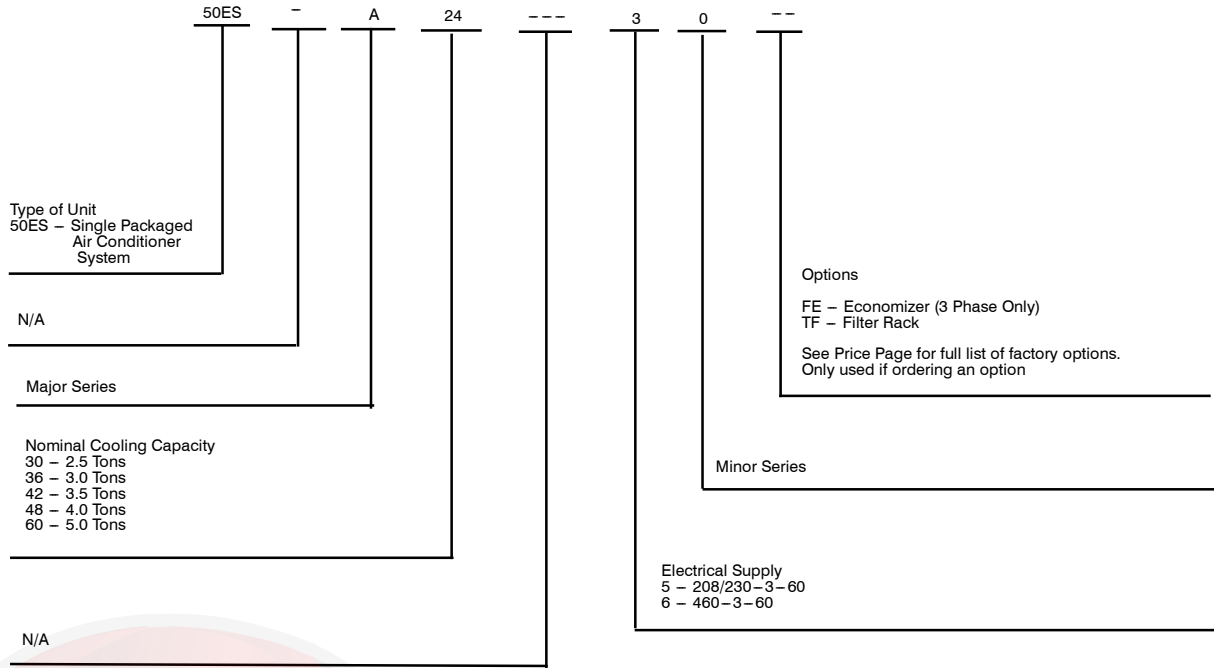

50ES--A



Use of the AHRI Certified TM Mark indicates a manufacturer's participation in the program For verification of certification for individual products, go to www.ahridirectory.org.

ClimateDirectors.com

AHRI* CAPACITIES

Cooling Capacities and Efficiencies

UNIT SIZE	NOMINAL TONS	STANDARD CFM	NET COOLING CAPACITIES (Btuh)	EER**	SEER†
30	2-1/2	1000	28,400	11.2	13.5
36	3	1200	34,400	11.0	13.0
42	3-1/2	1400	40,500	11.2	13.2
48	4	1600	46,500	11.2	13.2
60	5	1750	57,000	11.0	13.4

LEGEND

dB—Sound Levels (decibels)

db—Dry Bulb

SEER—Seasonal Energy Efficiency Ratio

wb—Wet Bulb

COP—Coefficient of Performance

* Air Conditioning, Heating & Refrigeration Institute.

**At "A" conditions—80°F (26.7°C) indoor db/67°F (19.4°C) indoor wb & 95°F (35°C) outdoor db.

† Rated in accordance with U.S. Government DOE Department of Energy) test procedures and/or AHRI Standards 210/240.

Notes:

1. Ratings are net values, reflecting the effects of circulating fan heat.

Ratings are based on:

Cooling Standard: 80°F (26.7°C) db, 67°F wb (19.4°C) indoor entering—air temperature and 95°F db (35°C) outdoor entering—air temperature.

2. Before purchasing this appliance, read important energy cost and efficiency information available from your retailer.

50ES--A

A-Weighted Sound Power Level (dBA)

UNIT SIZE	STANDARD RATING (dBA)	TYPICAL OCTAVE BAND SPECTRUM (dBA without tone adjustment)						
		125	250	500	1000	2000	4000	8000
30	75	66.0	63.5	68.0	68.5	67.5	61.5	55.0
36	75	64.0	63.5	68.0	70.5	64.5	61.0	61.0
42	77	67.0	67.0	69.5	70.5	68.0	65.5	61.0
48	78	71.5	66.5	73.0	71.5	68.0	64.0	57.0
60	78	74.5	66.5	70.0	70.0	66.5	64.0	57.0

* Tested in accordance with AHRI Standard 270—1995 (not listed in AHRI) physical data.



Physical Data-Unit 50ES-A

UNIT SIZE	30	36	42	48	60
NOMINAL CAPACITY (ton)	2-1/2	3	3-1/2	4	5
SHIPPING WEIGHT* lb.	284	290	378	384	406
SHIPPING WEIGHT* (kg)	129	132	171	174	184
COMPRESSORS	Scroll				
Quantity	1				
REFRIGERANT (R-410A)					
Quantity lb	6.2	6.4	6.1	6.4	10.0
Quantity (kg)	2.8	2.9	2.7	2.9	4.5
REFRIGERANT METERING DEVICE	TXV				
OUTDOOR COIL					
Rows...Fins/in.	1...21	1...21	1...21	1...21	2...21
Face Area (sq ft)	11.9	15.4	13.6	15.5	15.5
OUTDOOR FAN					
Nominal Cfm	3000	3200	3600	4000	3200
Diameter in.	24	24	26	26	26
Diameter (mm)	610	610	660	660	660
Motor Hp (Rpm)	1/5 (810)	1/5 (810)	1/5 (810)	1/5 (810)	1/5 (810)
INDOOR COIL					
Rows...Fins/in.	3...17	3...17	3...17	3...17	3...17
Face Area (sq ft)	3.7	3.7	4.7	4.7	5.7
INDOOR BLOWER					
Nominal Cooling Airflow (Cfm)	1000	1200	1400	1600	1750
Size in.	10x10	11x10	11x10	11x10	11x10
Size (mm.)	254x254	279.4x254	279.4x254	279.4x254	279.4x254
Motor HP (RPM)	1/2 (1050)	3/4 (1000)	3/4 (1075)	1.0 (1075)	1.0 (1040)
HIGH-PRESSURE SWITCH (psig) Cut-out Reset (Auto)	650 +/- 15 420 +/- 25				
LOSS-OF-CHARGE / LOW-PRESSURE SWITCH (Liquid Line) (psig) cut-out Reset (auto)	20 +/- 5 45 +/- 10				
RETURN-AIR FILTERS†‡					
Throwaway Size in.	20x24x1	24x30x1	24x30x1	24x36x1	24x36x1
Throwaway Size (mm)	508x610x25	610x762x25	610x762x25	610x914x25	610x914x25

*For 460 volt units add 14 lb (6.35 kg) to the shipping weight.

† Required filter sizes shown are based on the larger of the AHRI (Air Conditioning, Heating and Refrigeration Institute) rated cooling airflow or the heating airflow velocity of 300 ft/minute for throwaway type or 450 ft/minute for high-capacity type. Air filter pressure drop for non-standard filters must not exceed 0.08 in. W.C.

‡ If using accessory filter rack refer to the filter rack installation instructions for correct filter sizes and quantity.

ELECTRIC HEAT PRESSURE DROP TABLES (IN. W.C.)

Small Cabinet: 30-36

	500	600	700	800	900	1000	1100	1200	1300	1400	1500	1600
5kw	0.00	0.00	0.00	0.00	0.00	0.00	0.00	0.00	0.02	0.04	0.06	0.07
7.5 kw	0.00	0.00	0.00	0.00	0.00	0.00	0.02	0.03	0.05	0.07	0.08	0.09
10 kw	0.00	0.00	0.00	0.00	0.00	0.02	0.04	0.06	0.07	0.09	0.10	0.11
15 kw	0.00	0.00	0.00	0.02	0.04	0.06	0.08	0.10	0.12	0.14	0.16	0.18
20 kw	0.00	0.00	0.02	0.04	0.06	0.08	0.09	0.11	0.13	0.15	0.17	0.19

Large Cabinet: 42-60

	1100	1200	1300	1400	1500	1600	1700	1800	1900	2000	2100	2200	2300	2400	2500
5kw	0.00	0.00	0.00	0.01	0.02	0.03	0.04	0.05	0.06	0.07	0.08	0.09	0.10	0.11	0.12
7.5 kw	0.00	0.00	0.01	0.02	0.03	0.04	0.05	0.06	0.07	0.08	0.09	0.10	0.11	0.12	0.13
10 kw	0.00	0.00	0.01	0.02	0.03	0.04	0.05	0.06	0.07	0.08	0.09	0.10	0.11	0.12	0.13
15 kw	0.00	0.02	0.03	0.04	0.05	0.06	0.07	0.08	0.09	0.10	0.11	0.12	0.13	0.14	0.15
20 kw	0.02	0.03	0.04	0.05	0.06	0.07	0.08	0.09	0.10	0.11	0.12	0.13	0.14	0.15	0.16

OPTIONS AND ACCESSORIES

ITEM	DESCRIPTION	FACTORY INSTALLED OPTION	FIELD INSTALLED ACCESSORY
Coil Options	Base unit with tin plated indoor coil hairpins	X	
Corporate Thermostats	Thermostats provide control for the system heating and cooling functions.		X
Crankcase Heater	Crankcase Heater provides anti-floodback protection for low-load cooling applications.		X*
Economizer	Horizontal Economizer with solid state controls and barometric relief dampers includes filter racks and provide outdoor air during cooling and reduce compressor operation.		X
	Vertical Economizer with solid state controls and barometric relief dampers includes filter racks and provide outdoor air during cooling and reduce compressor operation.	X	X
Electric Heaters	Electric Heat Supplement		X
Filter Rack	Filter Rack features easy installation, serviceability, and high-filtering performance for vertical applications. Includes 1-in. filter.	X	X
Flat Roof Curb	14-in. (356 mm) Flat Roof Curb is available for roof mounted applications.		X
Low Ambient Kit	Low Ambient Kit (Motormaster II Control) allows the use of mechanical cooling down to outdoor temperatures as low as 0°F (-18°C) when properly installed.		X
Louver Metal Outdoor Coil Grilles	Louver Metal Outdoor Coil Grilles provides hail and vandalism protection.		X
Manual Outside Air Damper	Manual Outside Air Damper includes hood and filter rack with adjustable damper blade for up to 25% outdoor air.		X
Square-to-Round Duct Transition Kit	Square-to-Round Duct Transition Kit enable 24-48 size units to be fitted to 14 in. (356 mm) round ductwork.		X
Time Guard II	Automatically prevents the compressor from restarting for at least 4 minutes and 45 seconds after shutdown of the compressor. Not required when a corporate programmable thermostat is applied or with a RTU-MP control.		X
Dual Point Electric Heaters	Allows you to power the electric heater and unit contactor separately by having two individual field power supply circuits connected respectively.		X

*Refer to Price Page for application detail.

Electric Heaters

CATALOG ORDERING NO.	NOMINAL CAPACITY (kW)	FUSE QTY	USED WITH SIZES				
			30	36	42	48	60
ELECTRIC HEATERS (208/230 — THREE PHASE — 60 Hz)							
CPHEATER055A00	5.0	—	X	X	X	X	X
CPHEATER056A00	10.0	—	X	X	X	X	X
CPHEATER068A00	10.0	6	X	X	X	X	X
CPHEATER057A00	15.0	—	X	X	X	X	X
CPHEATER058A00	15.0	6	X	X	X	X	X
CPHEATER059A01	20.0	6			X	X	X
ELECTRIC HEATERS (460 — THREE PHASE — 60 Hz)							
CPHEATER060A00	5.0	—		X	X	X	X
CPHEATER061A00	10.0	—		X	X	X	X
CPHEATER062A00	15.0	—		X	X	X	X
CPHEATER063A00	20.0	—			X	X	X

NOTE: Electric heaters are rated at 240v. Refer to Multiplication Factors table for other voltages.

X = Approved combinations.

Minimum Airflow for Safe Electric Heater Operation (CFM)

SIZE	30	36	42	48	60
CFM	1000	1200	1400	1600	1750

ECONOMIZER

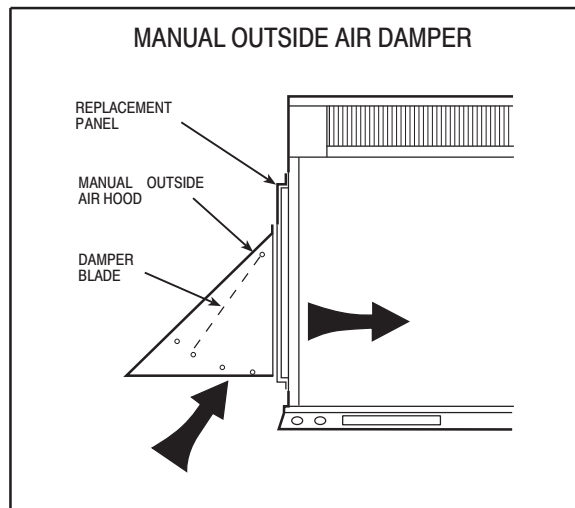
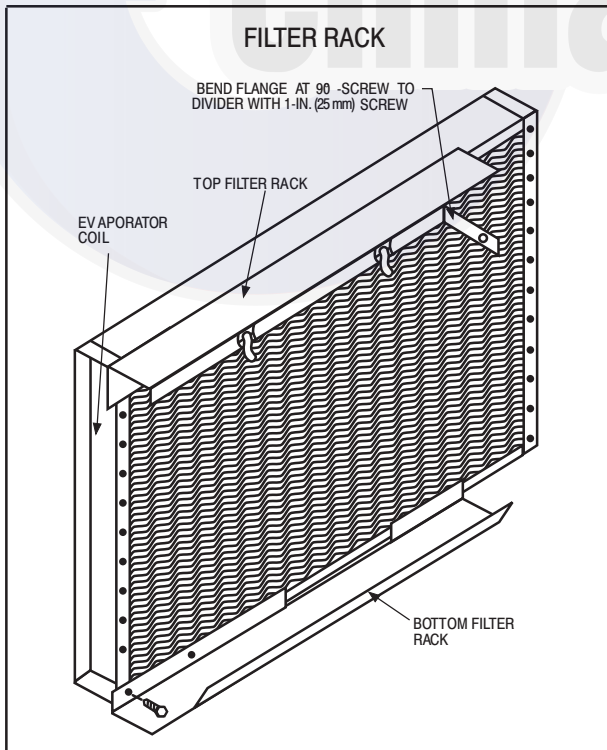
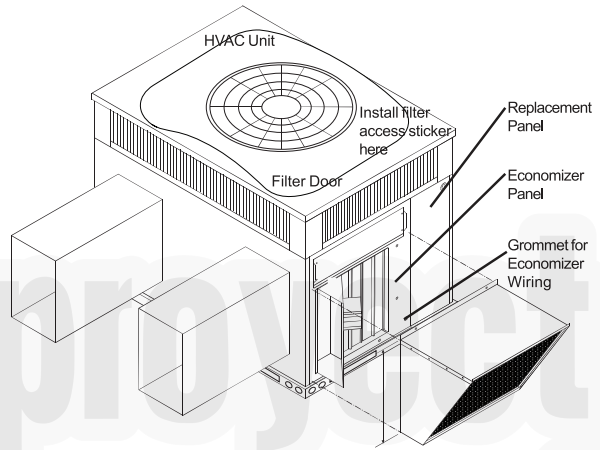
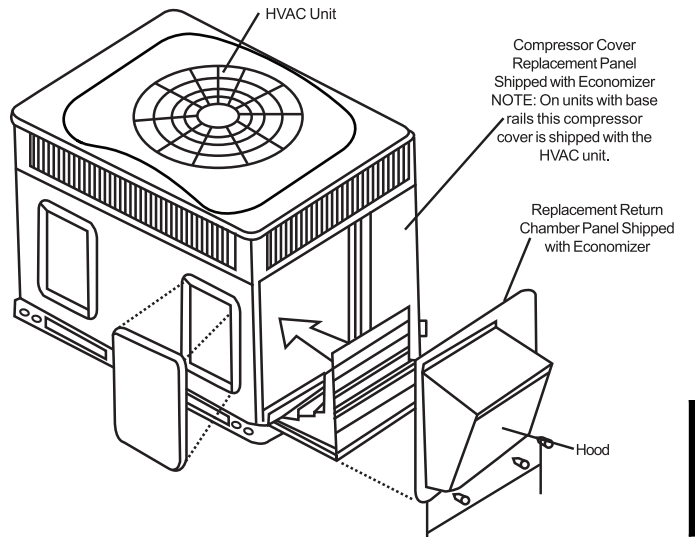
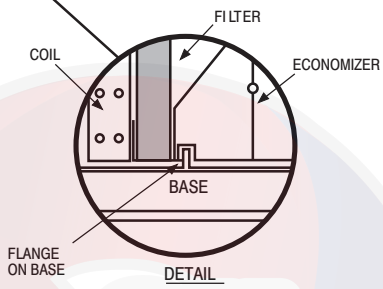
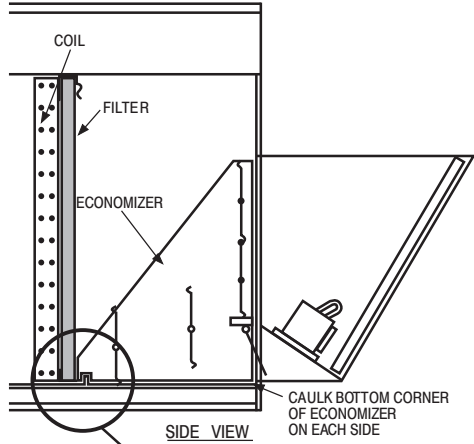

50ES--A

UNIT DIMENSIONS - 50ES-A30-36

50ES--A

UNIT	ELECTRICAL CHARACTERISTICS	UNIT WT. LB. KG	UNIT HEIGHT "A"	CENTER OF GRAVITY IN/MM		
				X	Y	Z
50ES-A30---50	208/230-3-60	277 125.5	42-11/8 1070	20-1/2 520.7	15-3/4 400.1	16-13/16 427.0
50ES-A36---50	208/230-3-60	283 128.3	46-1/8 1172	20-1/2 520.7	15-3/4 400.1	17 431.8
50ES-A36---60	460-3-60	297 134.6	46-1/8 1172	20-1/2 520.7	15-3/4 400.1	17 431.8

UNITS	VOLTAGE	CORNER WEIGHT LB/KG		
		"1"	"2"	"4"
50ES-A30---50	208/230	55.4 [25.1]	44.3 [20.1]	166.4 [30.2]
50ES-A36---50	208/230	56.6 [25.7]	45.2 [20.5]	167.9 [30.8]
50ES-A36---60	460	56.6 [25.7]	45.2 [20.5]	169.9 [34.9]

NOTE: ALL TABLE DATA RELEVANT FOR ALL FACTORY INSTALLED OPTIONS EXCEPT ECONOMIZER

REQUIRED CLEARANCES TO COMBUSTIBLE MATL.

	INCHES [MM]
TOP OF UNIT	14 [355.6]
DUCT SIDE OF UNIT	14 [355.6]
SIDE OPPOSITE DUCTS	14 [355.6]
BOTTOM OF UNIT	0 [0.0]
ELECTRICAL PANEL	36 [914.4]

NEC REQUIRED CLEARANCES.

	INCHES [MM]
BETWEEN UNITS, POWER ENTRY SIDE	42 [1066.8]
UNIT AND UNGROUNDED SURFACES, POWER ENTRY SIDE	36 [914.0]
UNIT AND BLOCK OR CONCRETE WALLS AND OTHER GROUNDED SURFACES, POWER ENTRY SIDE	42 [1066.8]

REQUIRED CLEARANCE FOR OPERATION AND SERVICING

	INCHES [MM]
EVAP. COIL ACCESS SIDE	36 [914.0]
MINIMUM CLEARANCE FOR REFRIG. SERVICE (EXCEPT FOR REFRIG. SERVICE)	42 [1066.8]
UNIT TOP (FOR REFRIG. SERVICE)	48 [1219.2]
SIDE OPPOSITE DUCTS	36 [914.0]
DUCT PANEL	12 [304.8]

*MINIMUM DISTANCES: IF UNIT IS PLACED LESS THAN 12 [304.8] FROM WALL SYSTEM, THEN SYSTEM PERFORMANCE MAYBE COMPROMISED.

DIMENSIONS IN [] ARE IN MILLIMETERS

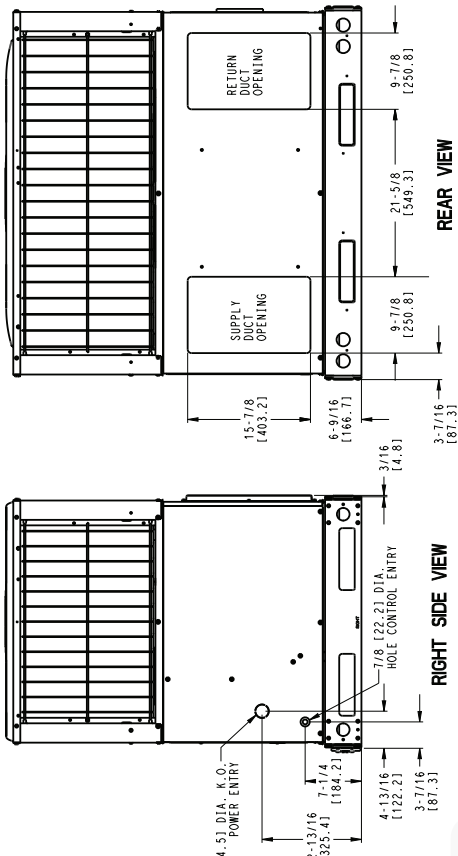
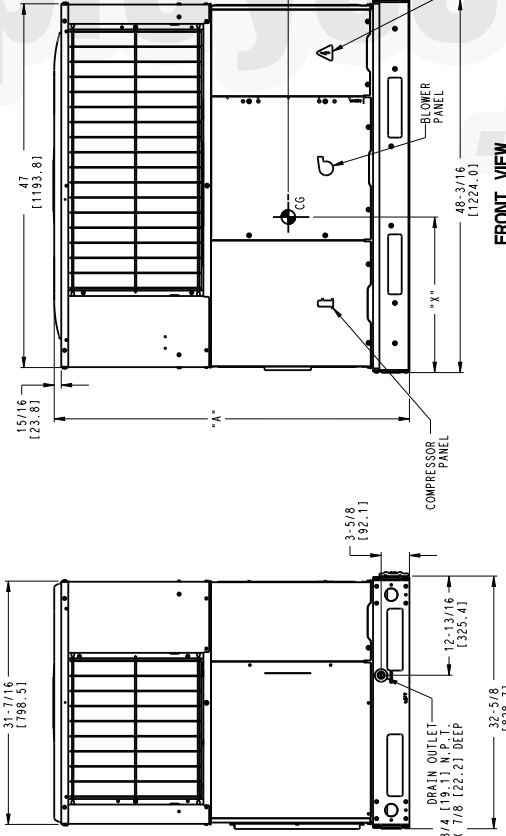
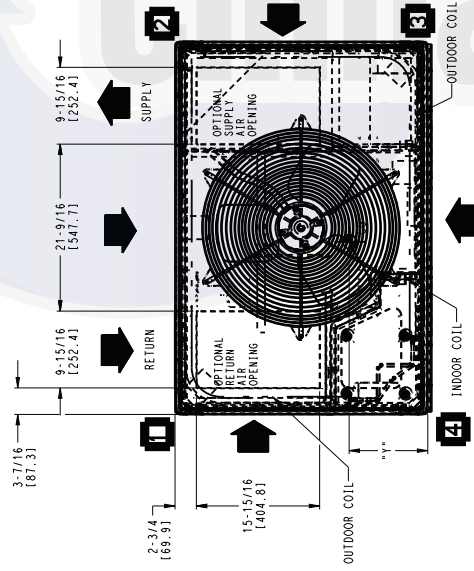

REV B
50ES500151

UNIT DIMENSIONS - 50ES-A42-60

UNIT	ELECTRICAL CHARACTERISTICS	UNIT WT.			UNIT HEIGHT			CENTER OF GRAVITY IN/MM			
		LB	KG	"A"	"B"	"C"	X	Y	Z		
50ES-A42---60	460-3-60	383	173.8	44-3/4	1137	20-1/4	514.4	17-1/2	444.5	17-1/8	435.0
50ES-A48---60	208/230-3-60	375	170.2	46-3/4	1187	20-1/4	514.4	17-1/2	444.5	17-3/8	441.3
50ES-A48---60	460-3-60	389	176.6	46-3/4	1187	20-1/4	514.4	17-1/2	444.5	17-3/8	441.3
50ES-A60---60	208/230-3-60	397	180.2	46-3/4	1187	20-1/4	514.4	17-1/2	444.5	17-5/8	447.7
50ES-A60---60	460-3-60	411	186.5	46-3/4	1187	20-1/4	514.4	17-1/2	444.5	17-5/8	447.7

UNITS	VOLTAGE	CORNER WEIGHT LB/KG		
		"1"	"2"	"3"
50ES-A42---60	460	73.8	33.5	59.1
50ES-A48---60	208/230	75.0	34.1	60.0
50ES-A48---60	460	75.0	34.1	60.0
50ES-A60---60	208/230	79.4	36.1	63.6
50ES-A60---60	460	79.4	36.1	63.6

REQUIRED CLEARANCES TO COMBUSTIBLE MTL

TOP OF UNIT..... 15-5/8" [395.6]
 DUCT SIDE OF UNIT..... 2" [50.8]
 SIDE OPPOSITE DUCTS..... 14" [355.6]
 BOTTOM OF UNIT..... 0" [0.0]
 ELECTRICAL PANEL..... 36" [914.4]

NEE. REQUIRED CLEARANCES

BETWEEN UNITS, POWER ENTRY SIDE..... 42" [1066.8]
 UNIT AND UNGROUNDED SURFACES, POWER ENTRY SIDE..... 36" [914.0]
 UNIT AND BLOCK OR CONCRETE WALLS AND OTHER GROUNDED SURFACES, POWER ENTRY SIDE..... 42" [1066.8]

REQUIRED CLEARANCE FOR OPERATION AND SERVICING

EVAP. COIL ACCESS SIDE..... 36" [914.0]
 POWER ENTRY SIDE..... 42" [1066.8]
 UNIT TOP..... 48" [1219.2]
 SIDE OPPOSITE DUCTS..... 36" [914.0]
 DUCT PANEL..... 12" [304.8]

*MINIMUM DISTANCES: IF UNIT IS PLACED LESS THAN 12" (304.8) FROM WALL SYSTEM, THEN SYSTEM PERFORMANCE MAYBE COMPROMISED.

NOTE: ALL TABLE DATA RELEVANT FOR ALL FACTORY INSTALLED OPTIONS EXCEPT ECONOMIZER

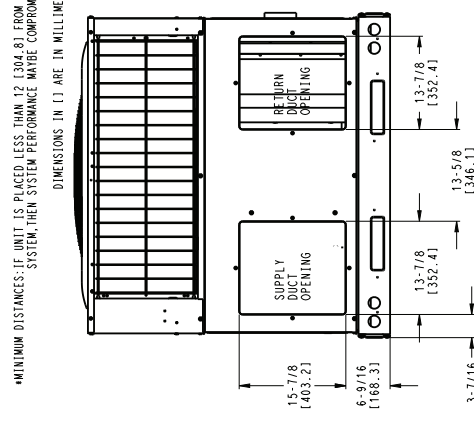
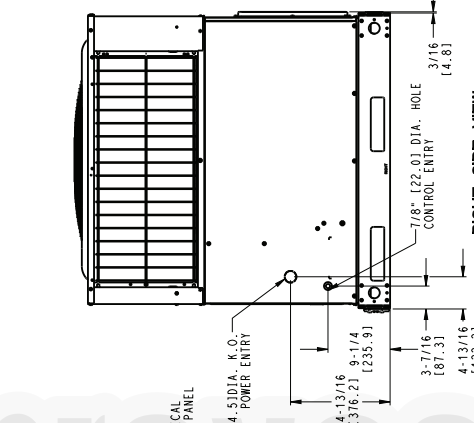
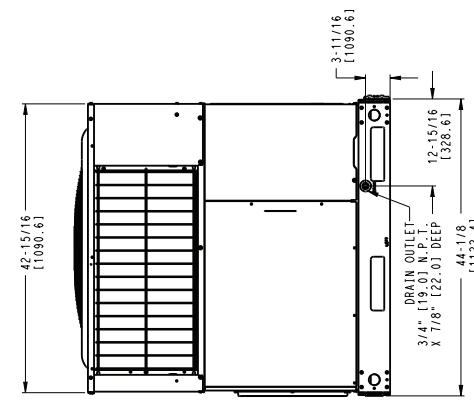
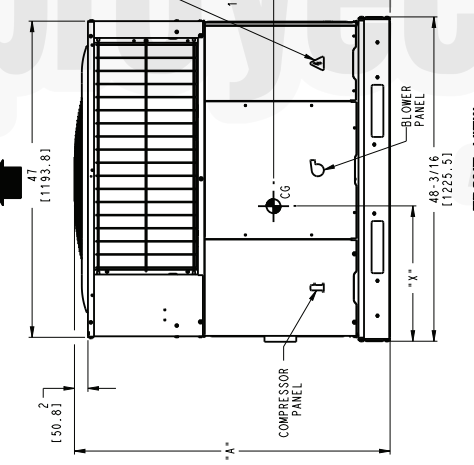
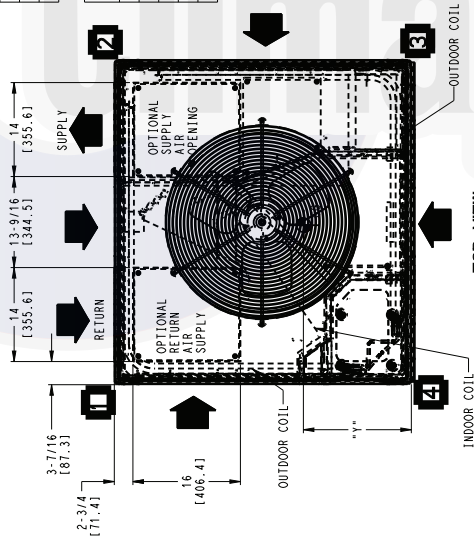

50ES500152 REV B

50ES--A

LEFT SIDE VIEW

FRONT VIEW

RIGHT SIDE VIEW

REAR VIEW

ROOF CURB ACCESSORY - 50ES-A30-60

50ES--A

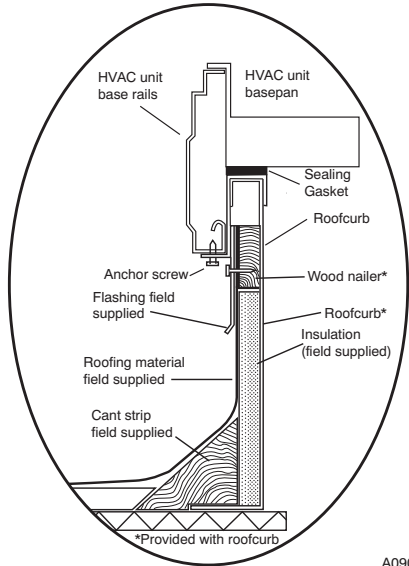

A09090

ROOF CURB DETAIL

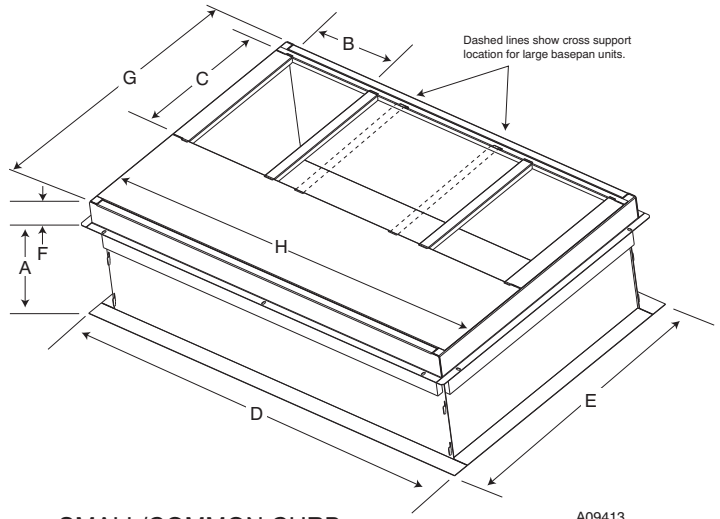

A09413

SMALL/COMMON CURB

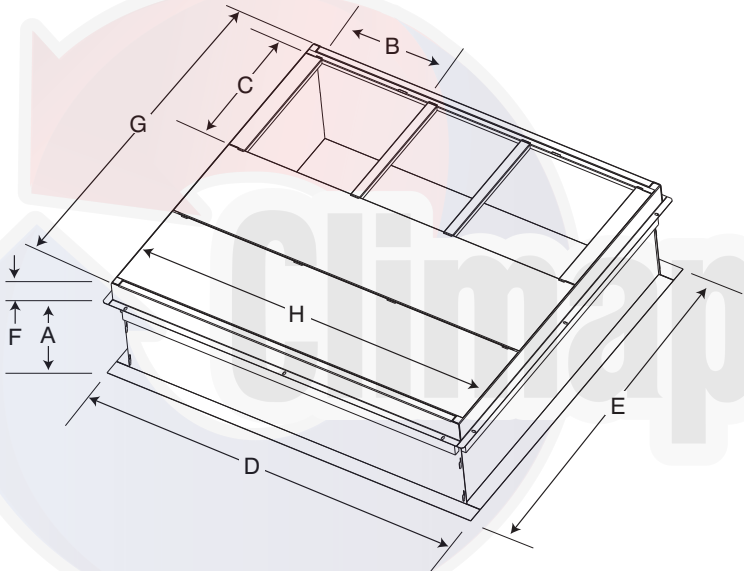

A09415

LARGE CURB

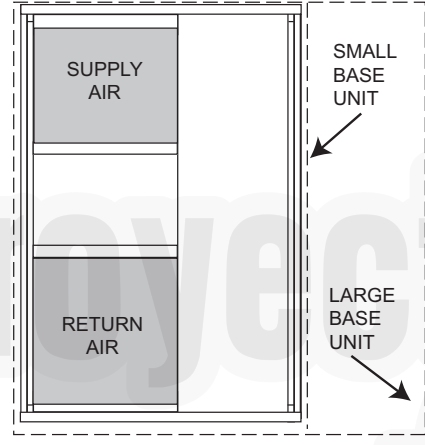

A09094

UNIT PLACEMENT ON COMMON CURB

SMALL OR LARGE BASE UNIT

A09414

UNIT SIZE	CATALOG NUMBER	A IN. (mm)	B (small/common base) IN. (mm)*	B (large base) IN. (mm)*	C IN. (mm)	D IN. (mm)	E IN. (mm)	F IN. (mm)	G IN. (mm)	H IN. (mm)
Small or Large	CPRFCURB011A00	14 (356)	10 (254)	14 (356)	16 (406)	47.8 (1214)	32.4 (822)	2.7 (69)	30.6 (778)	46.1 (1170)
Large	CPRFCURB013A00	14 (356)	14 (356)				43.9 (1116)		42.2 (1072)	

* Part Number CPRFCURB011A00 can be used on both small and large basepan units. The cross supports must be located based on whether the unit is a small basepan or a large basepan.

- NOTES:
1. Roof curb must be set up for unit being installed.
 2. Seal strip must be applied, as required, to unit being installed.
 3. Roof curb is made of 16-gauge steel.
 4. Attach ductwork to curb (flanges of duct rest on curb).
 5. Insulated panels: 1-in. (25.4 mm) thick fiberglass 1 lb. density.

SELECTION PROCEDURE (WITH EXAMPLE)

1. Determine cooling and heating requirements at design conditions:

Given:

Required Cooling Capacity (TC)	34,000 Btuh
Sensible Heat Capacity (SHC)	25,000 Btuh
Required Heating Capacity	30,000 Btuh
Condenser Entering Air Temperature	95°F(35°C)
Indoor-Air Temperature	80°F (26°C) edb 67°F (19°C) ewb
Evaporator Air Quantity	1200 CFM
External Static Pressure	0.30 IN. W.C.
Electrical Characteristics	230-3-60

2. Select unit based on required cooling capacity.

Enter Net Cooling Capacities table at condenser entering temperature of 95°F (35°C), indoor air entering at 1200 CFM and 67°F (19°C) ewb (entering wet bulb). The unit will provide a total capacity of 34,400 Btuh and a SHC of 25,900 Btuh.

3. Select electric heat.

The required heating capacity is 30,000 Btuh.

Determine additional electric heat capacity in kW.

$$\frac{30,000 \text{ Btuh}}{3,414 \text{ Btuh/kW}} = 8.8 \text{ kW of heat required}$$

Enter the electric Heater Packages table for 208/240, three-phase, 50ES-A36 unit. The 10 kW heater at 240v most closely satisfies the heating required. To calculate kW at the 230v, multiply the heater kW by multiplication factor 0.92 found in the Wattage Multiplication Factors table.

$$10 \text{ kW} \times 0.92 = 9.2 \text{ kW}$$

$$9.2 \text{ kW} \times 3414 = 31,409 \text{ Btuh}$$

4. Determine fan speed and power requirements at design conditions.

Before entering the air delivery tables, calculate the total static pressure required. From the given example, the Wet Coil Pressure Drop Table, and the Filter Pressure Drop Table:

External Static Pressure	0.30 IN. W.C.
Filter	0.14 IN. W.C.
Wet Coil Pressure Drop	<u>0.10 IN. W.C.</u>
Total Static Pressure	0.54 IN. W.C.

Enter the table for Wet Coil Air Delivery—horizontal discharge, 230. At 0.60 IN. W.C. ESP (external static pressure) and medium-high speed, the fan will deliver 1316 CFM.

5. Select unit that corresponds to power source available.

The Electrical Data Table shows that the unit is designed to operate at 208/230-3-60.

50ES--A

Climaproyectos.com

PERFORMANCE DATA

50ES-A30

EVAPORATOR AIR		CONDENSER ENTERING AIR TEMPERATURES °F (°C)																	
		75 (23.9)			85 (29.4)			95 (35)			105 (40.6)			115 (46.1)			125 (51.7)		
		CFM/BF	EWB °F (°C)	Total Sys KW	Capacity MBtuh	Sens	Total Sys KW	Capacity MBtuh	Sens	Total Sys KW	Capacity MBtuh	Sens	Total Sys KW	Capacity MBtuh	Sens	Total Sys KW	Capacity MBtuh	Sens	Total Sys KW
875/0.03	57 (13.8)	29.20	2.09	27.20	27.20	2.30	25.19	25.19	2.52	23.18	23.18	2.77	21.16	21.16	3.04	19.13	19.13	3.32	
	62 (16.6)	30.09	2.09	27.78	25.28	2.30	25.48	24.10	2.52	23.22	23.12	2.77	21.16	21.16	3.04	19.12	19.12	3.32	
	63* (17.2)	30.75	2.09	28.36	20.61	2.30	25.99	19.56	2.52	23.63	18.51	2.77	21.26	17.45	3.04	18.90	16.38	3.32	
	67 (19.4)	33.12	2.08	30.58	21.34	2.29	28.05	20.29	2.52	25.62	19.23	2.77	23.00	18.16	3.04	20.48	17.08	3.32	
	72 (22.2)	36.50	2.08	33.73	17.33	2.29	30.97	16.37	2.52	28.22	15.41	2.77	25.48	14.44	3.04	22.73	13.46	3.32	
	57 (13.8)	30.51	2.12	28.39	28.39	2.33	26.27	26.27	2.56	24.14	24.14	2.80	22.01	22.01	3.07	19.87	19.87	3.35	
	62 (16.6)	30.85	2.12	28.49	28.24	2.33	26.26	26.26	2.56	24.14	24.14	2.80	22.01	22.01	3.07	19.86	19.86	3.35	
1000/0.03	63* (17.2)	31.44	2.12	28.97	22.02	2.33	26.51	20.93	2.56	24.07	19.84	2.81	21.63	18.73	3.07	19.21	17.60	3.35	
	67 (19.4)	33.86	2.12	31.22	22.85	2.33	28.60	21.75	2.55	25.99	20.65	2.80	23.40	19.53	3.07	20.80	18.40	3.35	
	72 (22.2)	37.30	2.11	34.43	18.29	2.32	31.58	17.30	2.55	28.74	16.31	2.80	25.91	15.31	3.07	23.07	14.29	3.35	
	57 (13.8)	31.61	2.15	29.39	29.39	2.36	27.17	27.17	2.59	24.95	24.95	2.84	22.72	22.72	3.10	20.48	20.48	3.39	
	62 (16.6)	31.61	2.15	29.39	29.39	2.36	27.17	27.17	2.59	24.95	24.95	2.84	22.72	22.72	3.10	20.48	20.48	3.39	
	63* (17.2)	31.97	2.15	29.43	23.38	2.36	26.91	22.25	2.59	24.41	21.10	2.84	21.92	19.95	3.10	19.45	18.75	3.39	
	67 (19.4)	34.42	2.15	31.71	24.30	2.36	29.02	23.16	2.59	26.95	22.01	2.84	23.69	20.84	3.10	21.05	19.65	3.39	
1125/0.04	72 (22.2)	37.91	2.14	34.96	19.20	2.35	32.03	18.19	2.58	29.12	17.17	2.83	26.22	16.14	3.10	23.32	15.10	3.39	

See Legend and Notes on Page 18.



PERFORMANCE DATA (CONT)

50ES-A36

EVAPORATOR AIR		CONDENSER ENTERING AIR TEMPERATURES °F (°C)																	
		75 (23.9)			85 (29.4)			95 (35)			105 (40.6)			115 (46.1)			125 (51.7)		
		Capacity MBtuh	Total Sys KW	Total Sys KW	Capacity MBtuh	Total Sys KW	Total Sys KW	Capacity MBtuh	Total Sys KW	Total Sys KW	Capacity MBtuh	Total Sys KW	Total Sys KW	Capacity MBtuh	Total Sys KW	Total Sys KW	Capacity MBtuh	Total Sys KW	Total Sys KW
1050/0.04	EWB °F (°C)																		
	57 (13.8)	35.66	2.38	32.84	2.71	30.06	3.07	27.32	3.47	24.62	3.91	21.93	4.39						
	62 (16.6)	37.06	2.39	33.82	2.71	30.65	3.07	27.56	3.47	24.62	3.91	21.93	4.39						
	63* (17.2)	37.87	2.39	34.55	2.71	31.28	3.08	28.09	3.48	24.95	3.91	21.88	4.39						
	67 (19.4)	40.79	2.39	37.23	2.72	33.74	3.08	30.32	3.48	26.96	3.92	23.65	4.39						
	72 (22.2)	44.91	2.39	41.02	2.72	37.19	3.09	33.45	3.49	29.78	3.93	26.16	4.40						
	57 (13.8)	37.24	2.43	34.27	2.76	31.33	3.12	28.44	3.52	25.58	3.96	22.76	4.44						
1200/0.04	62 (16.6)	37.97	2.43	34.64	2.76	31.35	3.12	28.43	3.52	25.58	3.96	22.75	4.44						
	63* (17.2)	38.73	2.43	35.29	2.76	31.91	3.12	28.60	3.52	25.37	3.96	22.21	4.44						
	67 (19.4)	41.71	2.44	38.02	2.76	34.40	3.13	30.86	3.53	27.40	3.97	24.00	4.44						
	72 (22.2)	45.90	2.44	41.86	2.77	37.91	3.13	34.05	3.54	30.26	3.98	26.53	4.45						
	57 (13.8)	38.59	2.48	35.47	2.81	32.40	3.17	29.37	3.57	26.39	4.01	23.43	4.49						
	62 (16.6)	38.77	2.48	35.46	2.81	32.39	3.17	29.37	3.57	26.38	4.01	23.43	4.49						
	63* (17.2)	39.40	2.48	35.85	2.81	32.38	3.17	28.99	3.57	25.69	4.01	22.46	4.49						
1350/0.05	67 (19.4)	42.41	2.48	38.61	2.81	34.89	3.18	31.27	3.58	27.72	4.02	24.26	4.49						
	72 (22.2)	46.65	2.49	42.51	2.82	38.45	3.18	34.49	3.58	30.61	4.03	26.80	4.50						

See Legend and Notes on Page 18.

PERFORMANCE DATA (CONT)

50ES-A42

EVAPORATOR AIR CFM/BF	EWB °F (°C)	CONDENSER ENTERING AIR TEMPERATURES °F (°C)												Total Sys KW				
		75 (23.9)			85 (29.4)			95 (35)			105 (40.6)			115 (46.1)			125 (51.7)	
		Capacity MBtuh	Sens	Total Sys KW	Capacity MBtuh	Sens	Total Sys KW	Capacity MBtuh	Sens	Total Sys KW	Capacity MBtuh	Sens	Total Sys KW	Capacity MBtuh	Sens	Total Sys KW	Capacity MBtuh	Sens
1225/0.03	57 (13.8)	40.45	40.45	3.00	37.98	3.37	35.49	35.49	3.78	32.98	32.98	4.20	30.44	30.44	4.65	27.84	27.84	5.10
	62 (16.6)	42.06	37.63	2.94	35.73	3.33	36.25	33.83	3.74	33.37	31.92	4.18	30.48	30.39	4.64	27.88	27.88	5.10
	63* (17.2)	42.83	30.96	2.91	29.27	3.31	36.96	27.59	3.72	33.97	25.92	4.17	30.95	24.26	4.63	27.90	22.59	5.10
	67 (19.4)	46.12	31.94	2.80	30.23	3.19	39.72	28.52	3.61	36.53	26.83	4.05	33.31	25.15	4.52	30.04	23.46	4.99
	72 (22.2)	50.58	26.16	2.65	24.61	3.04	43.59	23.08	3.46	40.11	21.56	3.90	36.60	20.05	4.37	33.04	18.53	4.84
	57 (13.8)	42.24	42.24	2.98	39.61	3.35	36.97	36.97	3.76	34.32	34.32	4.18	31.63	31.63	4.63	28.88	28.88	5.08
1400/0.04	62 (16.6)	43.11	40.44	2.95	38.38	3.34	37.15	36.28	3.75	34.31	34.31	4.18	31.62	31.62	4.63	28.88	28.88	5.08
	63* (17.2)	43.91	32.97	2.92	31.21	3.32	37.71	29.45	3.73	34.61	27.70	4.18	31.49	25.96	4.64	28.35	24.21	5.12
	67 (19.4)	47.15	34.07	2.81	32.28	3.20	40.50	30.50	3.62	37.19	28.73	4.06	33.86	26.97	4.53	30.50	25.20	5.00
	72 (22.2)	51.67	27.51	2.65	25.91	3.05	44.42	24.32	3.46	40.81	22.75	3.91	37.19	21.19	4.38	33.51	19.62	4.85
	57 (13.8)	43.75	43.75	2.97	40.99	3.34	38.22	38.22	3.75	35.43	35.43	4.17	32.62	32.62	4.62	29.74	29.74	5.07
	62 (16.6)	44.02	42.95	2.96	41.01	3.34	38.21	38.21	3.75	35.43	35.43	4.17	32.61	32.61	4.62	29.74	29.74	5.07
1575/0.05	63* (17.2)	44.67	34.90	2.94	33.06	3.33	38.28	31.23	3.75	35.10	29.41	4.20	31.91	27.58	4.66	28.70	25.74	5.14
	67 (19.4)	47.93	36.13	2.82	34.26	3.21	41.09	32.40	3.63	37.69	30.56	4.08	34.28	28.71	4.54	30.85	26.85	5.02
	72 (22.2)	52.51	28.80	2.67	27.15	3.06	45.05	25.51	3.48	41.34	23.89	3.93	37.63	22.28	4.39	33.86	20.67	4.87

See Legend and Notes on Page 18.



PERFORMANCE DATA (CONT)

50ES-A48

EVAPORATOR AIR		CONDENSER ENTERING AIR TEMPERATURES °F (°C)																	
		75 (23.9)			85 (29.4)			95 (35)			105 (40.6)			115 (46.1)			125 (51.7)		
		CFMBF	EWB °F (°C)	Capacity MBtuh	Total Sys KW	Capacity MBtuh	Total Sys KW	Capacity MBtuh	Total Sys KW	Capacity MBtuh	Total Sys KW	Capacity MBtuh	Total Sys KW	Capacity MBtuh	Total Sys KW	Capacity MBtuh	Total Sys KW		
1400/0.04	57 (13.8)	46.51	43.60	3.29	40.66	4.11	37.70	4.56	34.70	5.05	31.64	5.55	28.93	5.04	27.21	5.55			
	62 (16.6)	48.43	40.09	3.29	41.60	4.10	38.19	4.56	34.81	5.05	31.64	5.55	30.61	5.04	28.93	5.55			
	63* (17.2)	49.45	32.87	3.29	42.43	4.10	38.89	4.56	35.34	5.05	31.75	5.55	30.61	5.04	28.93	5.55			
	67 (19.4)	53.14	49.39	3.29	45.62	4.10	41.85	4.55	38.05	5.04	34.20	5.55	30.61	5.04	28.93	5.55			
	72 (22.2)	58.33	54.23	3.28	50.11	4.09	46.00	4.55	41.85	5.03	37.64	5.54	30.61	5.04	28.93	5.55			
	57 (13.8)	48.55	45.46	3.35	42.35	4.16	39.21	4.61	36.04	5.10	32.81	5.60	30.61	5.04	28.93	5.55			
	62 (16.6)	49.82	43.02	3.35	42.60	4.16	39.21	4.61	36.04	5.10	32.80	5.60	30.61	5.04	28.93	5.55			
1600/0.05	63* (17.2)	50.57	46.92	3.35	43.27	4.16	39.61	4.61	35.94	5.10	32.24	5.60	30.61	5.04	28.93	5.55			
	67 (19.4)	54.31	50.41	3.34	46.50	4.15	42.59	4.61	38.66	5.09	34.70	5.60	30.61	5.04	28.93	5.55			
	72 (22.2)	59.58	55.92	3.34	51.05	4.15	46.80	4.60	42.51	5.08	38.17	5.59	30.61	5.04	28.93	5.55			
	57 (13.8)	50.26	47.02	3.40	43.76	4.21	40.47	4.66	37.15	5.15	33.76	5.65	30.61	5.04	28.93	5.55			
	62 (16.6)	50.84	47.06	3.40	43.75	4.21	40.46	4.66	37.14	5.15	33.76	5.65	30.61	5.04	28.93	5.55			
	63* (17.2)	51.44	47.67	3.40	43.92	4.21	40.16	4.67	36.40	5.15	32.82	5.66	30.61	5.04	28.93	5.55			
	67 (19.4)	55.22	40.25	3.40	47.17	4.21	43.16	4.66	39.13	5.14	35.08	5.65	30.61	5.04	28.93	5.55			
1800/0.06	72 (22.2)	60.54	56.16	3.40	51.77	4.20	47.40	4.65	43.00	5.13	38.55	5.64	30.61	5.04	28.93	5.55			
	57 (13.8)	46.51	43.60	3.29	40.66	4.11	37.70	4.56	34.70	5.05	31.64	5.55	28.93	5.04	28.93	5.55			
	62 (16.6)	48.43	40.09	3.29	41.60	4.10	38.19	4.56	34.81	5.05	31.64	5.55	28.93	5.04	28.93	5.55			
	63* (17.2)	49.45	32.87	3.29	42.43	4.10	38.89	4.56	35.34	5.05	31.75	5.55	28.93	5.04	28.93	5.55			
	67 (19.4)	53.14	49.39	3.29	45.62	4.10	41.85	4.55	38.05	5.04	34.20	5.55	28.93	5.04	28.93	5.55			
	72 (22.2)	58.33	54.23	3.28	50.11	4.09	46.00	4.55	41.85	5.03	37.64	5.54	28.93	5.04	28.93	5.55			
	57 (13.8)	48.55	45.46	3.35	42.35	4.16	39.21	4.61	36.04	5.10	32.81	5.60	28.93	5.04	28.93	5.55			
See Legend and Notes on Page 18.	62 (16.6)	49.82	43.02	3.35	42.60	4.16	39.21	4.61	36.04	5.10	32.80	5.60	28.93	5.04	28.93	5.55			
	63* (17.2)	50.57	46.92	3.35	43.27	4.16	39.61	4.61	35.94	5.10	32.24	5.60	28.93	5.04	28.93	5.55			
	67 (19.4)	54.31	50.41	3.34	46.50	4.15	42.59	4.61	38.66	5.09	34.70	5.60	28.93	5.04	28.93	5.55			
	72 (22.2)	59.58	55.92	3.34	51.05	4.15	46.80	4.60	42.51	5.08	38.17	5.59	28.93	5.04	28.93	5.55			
	57 (13.8)	50.26	47.02	3.40	43.76	4.21	40.47	4.66	37.15	5.15	33.76	5.65	28.93	5.04	28.93	5.55			
	62 (16.6)	50.84	47.06	3.40	43.75	4.21	40.46	4.66	37.14	5.15	33.76	5.65	28.93	5.04	28.93	5.55			
	63* (17.2)	51.44	47.67	3.40	43.92	4.21	40.16	4.67	36.40	5.15	32.82	5.66	28.93	5.04	28.93	5.55			

See Legend and Notes on Page 18.



PERFORMANCE DATA (CONT)

50ES-A60

EVAPORATOR AIR		CONDENSER ENTERING AIR TEMPERATURES °F (°C)																	
		75 (23.9)			85 (29.4)			95 (35)			105 (40.6)			115 (46.1)			125 (51.7)		
		CFM/BF	EWB °F (°C)	Capacity MBtuh	Total Sys KW	Capacity MBtuh	Total Sys KW	Capacity MBtuh	Total Sys KW	Capacity MBtuh	Total Sys KW	Capacity MBtuh	Total Sys KW	Capacity MBtuh	Total Sys KW	Capacity MBtuh	Total Sys KW		
1750/0.02	57 (13.8)	57.89	57.89	4.22	54.53	54.53	4.64	51.13	51.13	5.08	47.68	47.68	5.56	44.15	44.15	6.06	40.50	40.50	6.59
	62 (16.6)	59.66	51.98	4.24	55.71	49.84	4.65	51.77	47.68	5.09	47.84	45.44	5.56	44.15	44.15	6.06	40.49	40.49	6.59
	63* (17.2)	60.79	42.58	4.25	56.72	40.64	4.66	52.64	38.69	5.10	48.53	36.74	5.57	44.37	34.78	6.06	40.12	32.78	6.58
	67 (19.4)	65.28	43.94	4.28	60.89	41.97	4.70	56.50	40.00	5.14	52.08	38.03	5.61	47.59	36.03	6.10	43.00	34.00	6.62
	72 (22.2)	71.52	35.78	4.34	66.71	33.95	4.75	61.88	32.13	5.19	57.02	30.30	5.66	52.07	28.45	6.15	47.01	26.57	6.66
	57 (13.8)	60.39	60.39	4.33	56.80	56.80	4.74	53.18	53.18	5.18	49.50	49.50	5.66	45.74	45.74	6.16	41.85	41.85	6.68
2000/0.02	62 (16.6)	61.11	55.94	4.33	57.07	53.59	4.74	53.18	53.18	5.18	49.50	49.50	5.66	45.74	45.74	6.16	41.85	41.85	6.68
	63* (17.2)	62.07	45.41	4.34	57.83	43.39	4.75	53.59	41.36	5.19	49.33	39.33	5.66	45.03	37.28	6.15	40.84	35.18	6.67
	67 (19.4)	66.80	46.95	4.38	62.04	44.89	4.79	57.48	42.84	5.23	52.89	40.78	5.69	48.25	38.70	6.19	43.52	36.58	6.70
	72 (22.2)	72.81	37.66	4.43	67.90	35.78	4.85	62.90	33.90	5.28	57.85	32.01	5.75	52.74	30.11	6.24	47.52	28.18	6.74
	57 (13.8)	62.47	62.47	4.43	58.69	58.69	4.84	54.87	54.87	5.28	51.00	51.00	5.75	47.03	47.03	6.25	42.94	42.94	6.77
	62 (16.6)	62.48	62.48	4.43	58.68	58.68	4.84	54.86	54.86	5.28	50.99	50.99	5.75	47.03	47.03	6.25	42.94	42.94	6.77
2250/0.03	63* (17.2)	63.04	48.14	4.43	58.67	46.04	4.84	54.31	43.93	5.28	49.93	41.81	5.74	45.52	39.67	6.23	41.04	37.45	6.75
	67 (19.4)	67.80	49.85	4.47	62.90	47.72	4.88	58.21	45.59	5.32	53.50	43.44	5.78	48.74	41.27	6.27	43.81	39.04	6.78
	72 (22.2)	73.95	39.47	4.53	68.79	37.54	4.94	63.63	35.61	5.37	58.45	33.68	5.84	53.20	31.73	6.32	47.86	29.75	6.82

See Legend and Notes on Page 18.



PERFORMANCE DATA (CONT)

* At 75°F (24°C) entering dry bulb – Tennessee Valley Authority (TVA) rating conditions; all others at 80°F (27°C) dry bulb.

LEGEND

BF—Bypass Factor
edb—Entering Dry—Bulb
Ewb—Entering Wet—Bulb
kW—Total Unit Power Input
SHC—Sensible Heat Capacity (1000 Btuh)
TC—Total Capacity (1000 Btuh) (net)
rh—Relative Humidity

COOLING NOTES:

1. Ratings are net; they account for the effects of the evaporator—fan motor power and heat.
2. Direct interpolation is permissible. Do not extrapolate.
3. The following formulas may be used:

$$t_{ldb} = t_{edb} - \frac{\text{Sensible capacity (Btuh)}}{1.10 \times \text{cfm}}$$

$$t_{wlb} = \frac{\text{Wet-bulb temperature corresponding to enthalpy air leaving evaporator coil (} t_{lwb} \text{)}}{4.5 \times \text{cfm}}$$

Where: h_{ewb} = Enthalpy of air entering evaporator coil

4. The SHC is based on 805 F (26.6°C) edb temperature of air entering evaporator coil. Below 80°F (26.6°C) edb, subtract (corr factor x cfm) from SHC. Above 805 F (26.6°C) edb, add (corr factor x cfm) to SHC.

Correction Factor = $1.10 \times (1 + \text{BF}) \times (\text{edb} - 80)$.

5. Integrated capacity is maximum (instantaneous) capacity less the effect of frost on the outdoor coil and the heat required to defrost it.

PERFORMANCE DATA (CONT)

Dry Coil Air Delivery* — Horizontal Discharge (CFM)

UNIT	MOTOR SPEED	WIRE COLOR	CFM	EXTERNAL STATIC PRESSURE (IN. W.C.)															
				0.1	0.2	0.3	0.4	0.5	0.6	0.7	0.8	0.9							
50ES-A30	Low	Blue	CFM	741	638	547	415	---	---	---	---	---	---	---	---	---	---	---	---
	Med-Low	Pink	CFM	973	887	823	733	665	538	451	---	---	---	---	---	---	---	---	---
	Medium	Red	CFM	1088	1023	954	881	800	723	658	583	513	461	400	350	300	250	200	150
	Med-High ¹	Orange	CFM	1140	1064	996	915	840	758	687	617	544	480	415	355	295	235	175	115
	High	Black	CFM	1202	1140	1082	1015	961	881	810	732	661	590	520	455	390	325	260	195
	Low	Blue	CFM	1234	1168	1093	1021	961	894	825	759	687	628	560	495	430	365	300	235
	Med-Low	Pink	CFM	1290	1223	1154	1090	1027	977	918	854	792	732	670	610	550	490	430	370
	Medium ¹	Red	CFM	1354	1290	1226	1158	1102	1046	988	932	878	828	778	728	678	628	578	528
50ES-A36	Med-High	Orange	CFM	1606	1546	1489	1430	1371	1316	1258	1208	1160	1110	1060	1010	960	910	860	810
	High	Black	CFM	1630	1580	1517	1463	1407	1339	1277	1210	1151	1100	1050	1000	950	900	850	800
	Low	Blue	CFM	1295	1234	1182	1126	1075	1016	955	898	842	785	730	675	620	565	510	455
	Med-Low	Pink	CFM	1345	1282	1235	1194	1140	1095	1027	974	921	868	815	762	710	657	605	552
	Medium	Red	CFM	1505	1452	1413	1358	1323	1282	1234	1169	1130	1080	1030	980	930	880	830	780
	Med-High ¹	Orange	CFM	1545	1492	1449	1411	1362	1313	1278	1231	1188	1145	1100	1055	1010	965	920	875
	High	Black	CFM	1705	1643	1607	1568	1518	1483	1448	1404	1360	1315	1270	1225	1180	1135	1090	1045
	Low	Blue	CFM	1402	1351	1311	1263	1224	1172	1122	1080	1041	1000	958	915	875	835	795	755
50ES-A48	Med-Low	Pink	CFM	1457	1404	1367	1318	1284	1233	1197	1144	1104	1064	1024	984	944	904	864	824
	Medium ¹	Red	CFM	1736	1695	1642	1601	1553	1512	1465	1427	1381	1341	1300	1260	1220	1180	1140	1100
	Med-High	Orange	CFM	2149	2111	2062	2026	1980	1945	1905	1864	1824	1784	1744	1704	1664	1624	1584	1544
	High	Black	CFM	2344	2306	2259	2203	2141	2070	1991	1902	1803	1704	1605	1506	1407	1308	1209	1110
	Med-Low	Pink	CFM	1678	1635	1602	1558	1513	1474	1438	1404	1369	1335	1298	1265	1230	1195	1160	1125
	Medium ¹	Red	CFM	1962	1915	1880	1843	1794	1753	1711	1675	1628	1590	1550	1510	1470	1430	1390	1350
	Med-High	Orange	CFM	2131	2088	2065	2013	1982	1941	1888	1860	1815	1775	1735	1695	1655	1615	1575	1535
	High	Black	CFM	2461	2409	2339	2286	2192	2140	2062	1968	1874	1780	1686	1592	1498	1404	1310	1216

* Air delivery values are without air filter and are for dry coil (See Horizontal Wet Coil Pressure Drop table).

¹ Factory-shipped cooling speed

Note: For horizontal applications deduct field-supplied air filter pressure drop and wet coil pressure drop to obtain external static pressure available for ducting.

For downflow applications see Wet Coil Air Delivery Downflow-High Speed with 1-in Filter and Economizer Table for available static including wet coil, 1-in, filter and economizer.

Shaded areas indicate airflow that are not recommended for dehumidification control.

Multiplication Factors

HEATER KW RATING	VOLTAGE DISTRIBUTION V/3/60	MULTIPLICATION FACTOR
240	200	0.69
	208	0.75
	230	0.92
	240	1.00

PERFORMANCE DATA (CONT)

Dry Coil Air Delivery* - Downflow Discharge

UNIT	MOTOR SPEED	WIRE COLOR	EXTERNAL STATIC PRESSURE (IN. W.C.)																
			0.10	0.20	0.30	0.40	0.50	0.60	0.70	0.80	0.90	1.0							
50ESA30	Low	CFM	756	669	548	457	--	--	--	--	--	--	--	--	--	--	--		
		WATTS	84	90	96	106	--	--	--	--	--	--	--	--	--	--	--	--	
		BHP	0.09	0.10	0.10	0.11	--	--	--	--	--	--	--	--	--	--	--	--	
	MedLow	CFM	1002	928	842	733	660	560	450	328	203	102	22	22	22	22	22	22	
		WATTS	144	155	161	173	185	192	203	203	203	203	203	203	203	203	203	203	
		BHP	0.15	0.17	0.17	0.19	0.20	0.21	0.22	0.22	0.22	0.22	0.22	0.22	0.22	0.22	0.22	0.22	0.22
	Medium	CFM	1110	1025	967	879	814	706	611	509	423	343	263	183	103	23	23	23	
		WATTS	188	195	205	211	223	236	243	255	255	255	255	255	255	255	255	255	255
		BHP	0.20	0.21	0.22	0.23	0.24	0.25	0.26	0.27	0.27	0.27	0.27	0.27	0.27	0.27	0.27	0.27	0.27
	MedHigh ¹	CFM	1160	1091	1004	945	866	804	699	615	496	377	258	139	23	23	23	23	
		WATTS	213	225	232	243	249	261	273	285	291	291	291	291	291	291	291	291	291
		BHP	0.23	0.24	0.25	0.26	0.27	0.28	0.29	0.31	0.31	0.31	0.31	0.31	0.31	0.31	0.31	0.31	0.31
High	CFM	1240	1173	1110	1031	966	902	821	726	626	526	426	326	226	126	26	26		
	WATTS	254	266	274	284	295	302	315	327	331	331	331	331	331	331	331	331	331	
	BHP	0.27	0.29	0.29	0.30	0.32	0.32	0.34	0.35	0.35	0.35	0.35	0.35	0.35	0.35	0.35	0.35	0.35	
50ESA36	Low	CFM	1277	1215	1147	1094	1045	992	932	874	826	774	722	670	618	566	514	462	
		WATTS	285	289	299	305	314	319	328	328	335	347	352	352	352	352	352	352	352
		BHP	0.31	0.31	0.32	0.33	0.34	0.34	0.35	0.35	0.36	0.37	0.38	0.38	0.38	0.38	0.38	0.38	0.38
	MedLow	CFM	1312	1260	1203	1153	1095	1050	995	943	889	839	787	735	683	631	579	527	475
		WATTS	314	324	329	340	344	355	361	372	382	387	387	387	387	387	387	387	387
		BHP	0.34	0.35	0.35	0.36	0.37	0.38	0.39	0.40	0.41	0.42	0.42	0.42	0.42	0.42	0.42	0.42	0.42
	Medium ¹	CFM	1381	1326	1269	1212	1161	1121	1070	1019	974	924	874	824	774	724	674	624	574
		WATTS	358	365	375	383	391	395	406	418	424	434	434	434	434	434	434	434	434
		BHP	0.38	0.39	0.40	0.41	0.42	0.42	0.44	0.45	0.45	0.45	0.45	0.45	0.45	0.45	0.45	0.45	0.45
	MedHigh	CFM	1631	1579	1525	1477	1423	1372	1336	1284	1233	1183	1133	1083	1033	983	933	883	833
		WATTS	567	576	581	592	598	609	617	619	613	598	598	598	598	598	598	598	598
		BHP	0.61	0.62	0.62	0.63	0.64	0.65	0.66	0.66	0.66	0.66	0.66	0.66	0.66	0.66	0.66	0.66	0.66
High	CFM	1681	1633	1575	1526	1478	1415	1366	1312	1249	1199	1149	1099	1049	999	949	899	849	
	WATTS	618	626	636	644	652	653	649	642	627	602	577	552	527	502	477	452	427	
	BHP	0.66	0.67	0.68	0.69	0.70	0.70	0.70	0.69	0.67	0.65	0.63	0.61	0.59	0.57	0.55	0.53	0.51	

Dry Coil Air Delivery* - Downflow Discharge

UNIT	MOTOR SPEED	WIRE COLOR	EXTERNAL STATIC PRESSURE (IN. W.C.)										
			0.10	0.20	0.30	0.40	0.50	0.60	0.70	0.80	0.90	1.0	
50ESA42	Low	CFM	1365	1324	1284	1233	1181	1127	1084	1039	984	939	
		WATTS	177	189	201	210	222	236	248	261	269	281	
	MedLow	BHP	0.19	0.20	0.22	0.23	0.24	0.25	0.27	0.28	0.29	0.30	
		CFM	1425	1384	1339	1301	1254	1199	1151	1104	1065	1015	
	Medium	WATTS	197	210	223	235	248	257	271	284	296	305	
		BHP	0.21	0.23	0.24	0.25	0.27	0.28	0.29	0.30	0.32	0.33	
	MedHigh ¹	CFM	1582	1549	1509	1469	1433	1392	1346	1300	1249	1213	
		WATTS	267	280	294	308	322	336	344	359	374	387	
	High	BHP	0.29	0.30	0.32	0.33	0.35	0.36	0.37	0.38	0.40	0.42	
		CFM	1623	1586	1553	1511	1470	1433	1393	1350	1309	1261	
	50ESA48	Low	WATTS	285	299	312	324	335	349	363	378	393	407
			BHP	0.31	0.32	0.33	0.35	0.36	0.37	0.39	0.41	0.42	0.44
MedLow		CFM	1775	1736	1696	1660	1622	1588	1557	1516	1472	1426	
		WATTS	371	386	401	410	424	439	453	468	483	497	
Medium ¹		BHP	0.40	0.41	0.43	0.44	0.45	0.47	0.49	0.50	0.52	0.53	
		CFM	1503	1457	1423	1374	1330	1287	1241	1199	1153	1111	
MedHigh		WATTS	225	233	246	254	269	282	292	307	314	329	
		BHP	0.24	0.25	0.26	0.27	0.29	0.30	0.31	0.33	0.34	0.35	
High		CFM	1556	1508	1461	1432	1388	1346	1302	1256	1221	1168	
		WATTS	244	261	268	281	290	305	319	330	345	353	
50ESA48		Low	BHP	0.26	0.28	0.29	0.30	0.31	0.33	0.34	0.35	0.37	0.38
			CFM	1861	1822	1786	1758	1716	1688	1660	1619	1583	1539
	MedLow	WATTS	400	417	426	441	452	467	482	492	507	519	
		BHP	0.43	0.45	0.46	0.47	0.48	0.50	0.52	0.53	0.54	0.56	
	Medium ¹	CFM	2319	2291	2255	2230	2193	2166	2118	2057	1992	1887	
		WATTS	758	769	787	799	808	823	822	805	780	737	
	MedHigh	BHP	0.81	0.82	0.84	0.86	0.87	0.88	0.88	0.86	0.84	0.79	
		CFM	2532	2487	2444	2391	2330	2259	2179	2111	2033	1949	
	High	WATTS	1014	1022	1015	994	965	935	898	858	823	786	
		BHP	1.09	1.10	1.09	1.07	1.03	1.00	0.96	0.92	0.88	0.84	



PERFORMANCE DATA (CONT)

Dry Coil Air Delivery* - Downflow Discharge

UNIT	MOTOR SPEED	WIRE COLOR	CFM	EXTERNAL STATIC PRESSURE (IN. W.C.)										
				0.10	0.20	0.30	0.40	0.50	0.60	0.70	0.80	0.90	1.0	
50ESA60	Low	Blue	CFM	1479	1436	1387	1346	1298	1253	1206	1160	1114	1061	
			WATTS	224	239	247	262	270	284	300	307	319	330	
			BHP	0.24	0.26	0.26	0.28	0.29	0.30	0.32	0.33	0.34	0.35	
	MedLow	Pink	CFM	1841	1796	1761	1724	1690	1651	1616	1578	1527	1478	
			WATTS	425	434	453	460	476	485	501	508	525	542	
			BHP	0.46	0.47	0.49	0.49	0.51	0.52	0.54	0.54	0.56	0.58	
	Medium ¹	Red	CFM	1944	1913	1872	1838	1801	1771	1731	1698	1655	1613	
			WATTS	486	501	511	529	537	554	565	578	595	603	
			BHP	0.52	0.54	0.55	0.57	0.58	0.59	0.61	0.62	0.64	0.65	
	MedHigh	Orange	CFM	2178	2148	2105	2073	2036	2002	1967	1919	1845	1751	
			WATTS	674	691	703	717	733	743	758	754	734	701	
			BHP	0.72	0.74	0.75	0.77	0.79	0.80	0.81	0.81	0.79	0.75	
High	Black	CFM	2480	2432	2375	2322	2236	2161	2085	2006	1917	1808		
		WATTS	1029	1012	995	975	941	908	869	836	796	751		
		BHP	1.10	1.09	1.07	1.05	1.01	0.97	0.93	0.90	0.85	0.81		

*Air delivery values are without air filter and are for dry coil (See Wet Coil Pressure Drop table).

¹ Factory-shipped cooling speed.

NOTE: Duct field-supplied air filter pressure drop and wet coil pressure drop to obtain external static pressure available for ducting. Shaded areas indicate speed/static combinations that are not permitted.

Wet Coil Pressure Drop (IN. W.C.)

UNIT SIZE	STANDARD CFM (SCFM)																
	600	700	800	900	1000	1100	1200	1300	1400	1500	1600	1700	1800	1900	2000	2100	2200
30				0.05	0.06	0.07	0.08	0.11									
36				0.06	0.06	0.09	0.10	0.11	0.14								
42					0.05	0.05	0.06	0.07	0.08	0.08	0.09	0.09	0.11				
48						0.04	0.04	0.06	0.09	0.10	0.10	0.11	0.12	0.13	0.14		
60										0.06	0.07	0.01	0.08	0.09	0.10	0.12	0.13

Economizer with 1-in. Filter Pressure Drop (IN. W.C.)

FILTER SIZE IN. (MM)	COOLING TONS	STANDARD CFM (SCFM)																
		600	700	800	900	1000	1100	1200	1300	1400	1500	1600	1700	1800	1900	2000	2100	2200
600-1400 CFM 12x20x1+12x20x1 (305x508x25+305x508x25)	2.5,	-	-	0.09	0.14	0.16	0.18	0.25	0.28	0.3	-	-	-	-	-	-	-	-
	3.0																	
1200-1800 CFM 16x24x1+14x24x1 (406x610x25+356x610x25)	3.5,	-	-	-	-	-	-	0.10	0.11	0.12	0.13	0.14	0.16	-	-	-	-	-
	4.0																	
1500-2200 CFM 16x24x1+18x24x1 (406x610x25+457x610x25)	5.0	-	-	-	-	-	-	-	-	-	0.15	0.17	0.18	0.20	0.21	0.22	0.23	0.23

Filter Pressure Drop Table (IN. W.C.)

FILTER SIZE IN. (MM)	COOLING TONS	STANDARD CFM (SCFM)																
		600	700	800	900	1000	1100	1200	1300	1400	1500	1600	1700	1800	1900	2000	2100	2200
600-1400 CFM 12x20x1+12x20x1 (305x508x25+305x508x25)	2.5,	0.03	0.05	0.06	0.08	0.10	0.11	0.13	0.14	0.16	-	-	-	-	-	-	-	-
	3.0																	
1200-1800 CFM 16x24x1+14x24x1 (406x610x25+356x610x25)	3.5,	-	-	-	-	-	-	0.07	0.08	0.09	0.09	0.10	0.11	0.12	-	-	-	-
	4.0																	
1500-2200 CFM 16x24x1+18x24x1 (406x610x25+457x610x25)	5.0	-	-	-	-	-	-	-	-	-	0.04	0.06	0.08	0.10	0.11	0.13	0.14	0.15

**Electric Heat Pressure Drop (IN. W.C.)
Small Cabinet: 30-36**

STANDARD CFM (S.C.F.M)												
	500	600	700	800	900	1000	1100	1200	1300	1400	1500	1600
5kw	0.00	0.00	0.00	0.00	0.00	0.00	0.00	0.00	0.02	0.04	0.06	0.07
7.5 kw	0.00	0.00	0.00	0.00	0.00	0.00	0.02	0.03	0.05	0.07	0.08	0.09
10 kw	0.00	0.00	0.00	0.00	0.00	0.02	0.04	0.06	0.07	0.09	0.10	0.11
15 kw	0.00	0.00	0.00	0.02	0.04	0.06	0.08	0.10	0.12	0.14	0.16	0.18
20 kw	0.00	0.00	0.02	0.04	0.06	0.08	0.09	0.11	0.13	0.15	0.17	0.19

**Electric Heat Pressure Drop (IN. W.C.)
Large Cabinet 42-60**

STANDARD CFM (S.C.F.M)															
	1100	1200	1300	1400	1500	1600	1700	1800	1900	2000	2100	2200	2300	2400	2500
5kw	0.00	0.00	0.00	0.01	0.02	0.03	0.04	0.05	0.06	0.07	0.08	0.09	0.10	0.11	0.12
7.5 kw	0.00	0.00	0.01	0.02	0.03	0.04	0.05	0.06	0.07	0.08	0.09	0.10	0.11	0.12	0.13
10 kw	0.00	0.00	0.01	0.02	0.03	0.04	0.05	0.06	0.07	0.08	0.09	0.10	0.11	0.12	0.13
15 kw	0.00	0.02	0.03	0.04	0.05	0.06	0.07	0.08	0.09	0.10	0.11	0.12	0.13	0.14	0.15
20 kw	0.02	0.03	0.04	0.05	0.06	0.07	0.08	0.09	0.10	0.11	0.12	0.13	0.14	0.15	0.16

TYPICAL PIPING AND WIRING

50ES--A

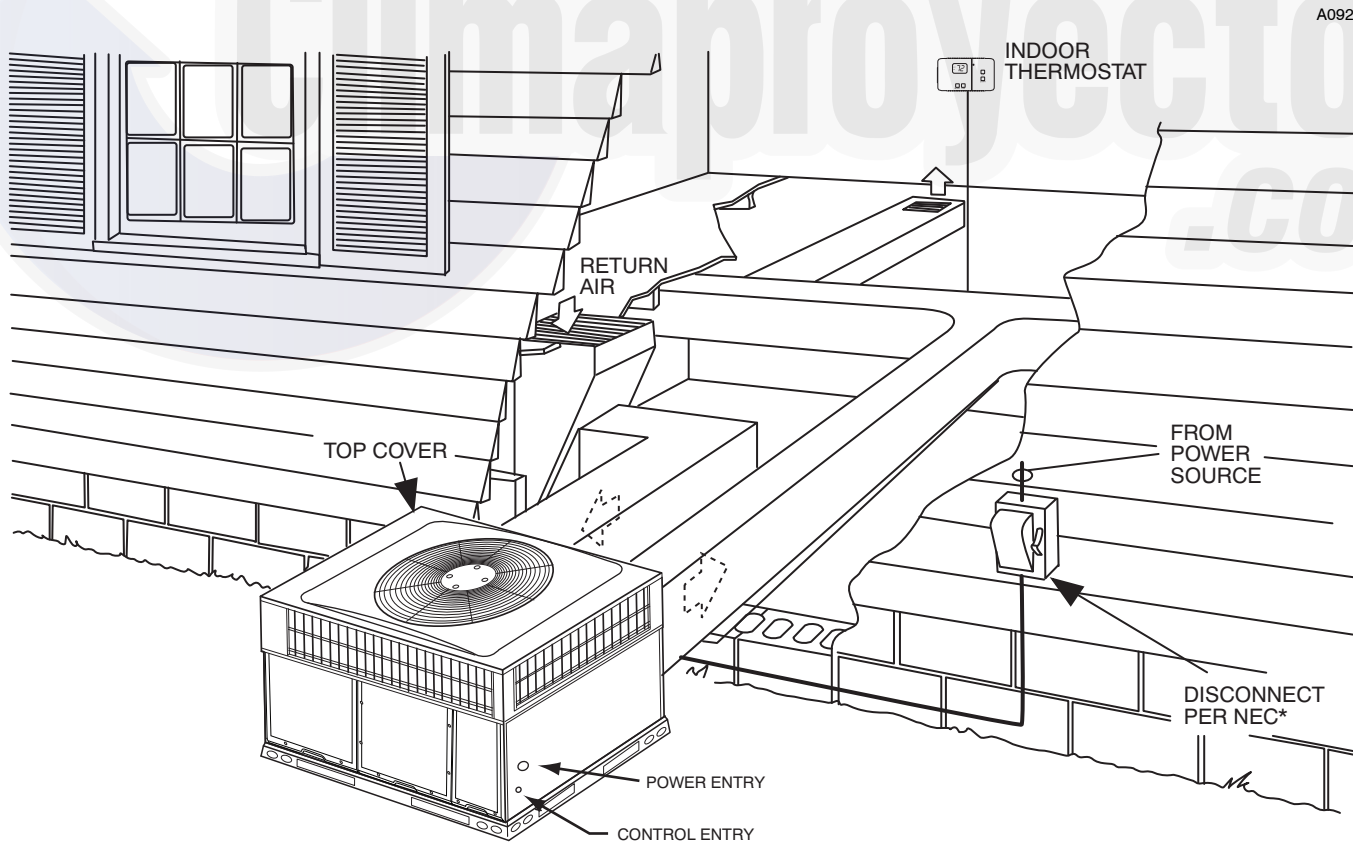
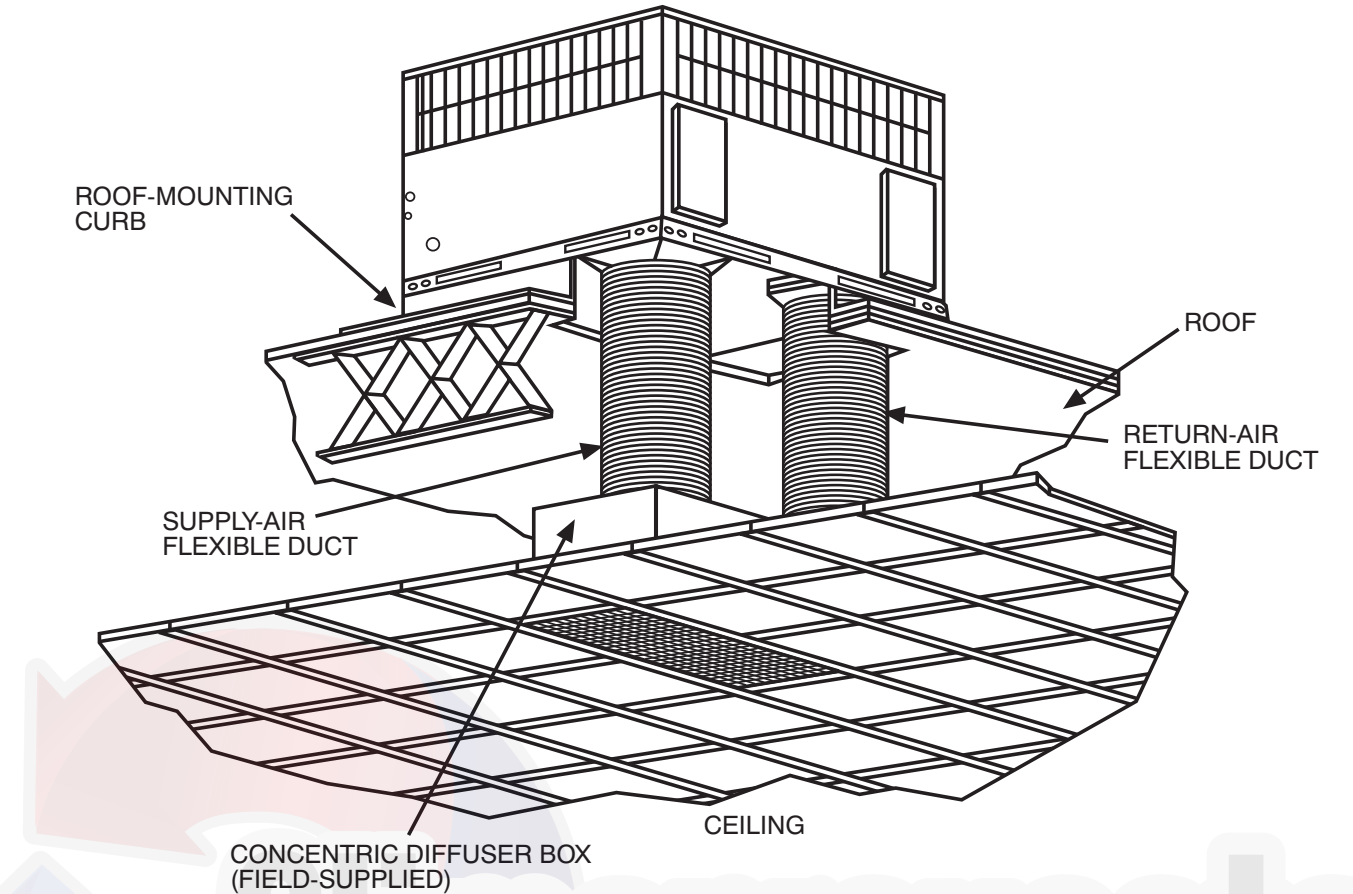

A09230

*NEC - National Electrical Code

A09240

APPLICATION DATA

Condensate trap — A 2-in. (50.8 mm) condensate trap must be field supplied.

Ductwork — Secure downflow discharge ductwork to roof curb. For horizontal discharge applications, attach ductwork to unit with flanges.

To convert a unit to downflow discharge — Units are equipped with factory-installed inserts in the downflow openings. Removal of the inserts is similar to removing an electrical knock-out.

Maximum cooling airflow — To minimize the possibility of condensate blow-off from the evaporator, airflow through the units should not exceed 450 cfm per ton.

Minimum cooling airflow — Minimum cooling airflow is 350 cfm per ton.

Minimum ambient cooling operation temperature — All standard units have a minimum ambient operating temperature of 40°F (4°C). With accessory low ambient temperature kit, units can operate at temperatures down to 0°F (-17°C).

50ES--A



ELECTRICAL DATA

50ES-A

50ES--A

UNIT	NOMINAL V- PH-HZ	VOLTAGE RANGE		COMPRESSOR		OFM	IFM	ELECTRIC HEAT			POWER SUPPLY				
		MIN	MAX	RLA	LRA	FLA	FLA	NOMINAL kW *	FLA		MCA			MOCP **	
									208	240	460	208	230		460
30	208/230-3-60	197	253	8.4	58.0	1.2	4.1	-/-	-	-	-	15.8	15.8	-	20
								3.8/5	10.4	12.0	-	18.1	20.1	-	20/25
								7.5/10	20.8	24.1	-	31.1	35.3	-	35/40
								11.3/15	31.3	36.1	-	44.3	50.3	-	45/60
36	208/230-3-60	197	253	10.4	88.0	1.2	6.0	-/-	-	-	-	20.3	20.3	-	30
								3.8/5	10.4	12.0	-	20.5	22.5	-	30/30
								7.5/10	20.8	24.1	-	33.5	37.6	-	35/40
								11.3/15	31.3	36.1	-	46.6	52.6	-	50/60
	460-3-60	414	506	5.8	38.0	0.5	3.0	-	-	-	-	-	-	10.7	15
								5	-	-	6.0	-	-	11.3	15
								10	-	-	12.0	-	-	18.8	20
								15	-	-	18.0	-	-	26.3	30
42	208/230-3-60	197	253	13.5	88.0	1.2	6.0	-/-	-	-	-	24.1	24.1	-	35
								3.8/5	10.4	12.0	-	24.1	24.1	-	35/35
								7.5/10	20.8	24.1	-	33.5	37.6	-	35/40
								11.3/15	31.3	36.1	-	46.6	52.6	-	50/60
								15/20	41.4	47.9	-	59.3	67.4	-	60/70
	460-3-60	414	506	6.0	44.0	0.5	3.0	-	-	-	-	-	-	11.0	15
								5	-	-	6.0	-	-	11.3	15
								10	-	-	12.0	-	-	18.8	20
								15	-	-	18.0	-	-	26.3	30
								20	-	-	24.1	-	-	33.9	35
48	208/230-3-60	197	253	13.7	83.1	1.2	7.6	-/-	-	-	-	25.9	25.9	-	35
								3.8/5	10.4	12.0	-	25.9	25.9	-	35/35
								7.5/10	20.8	24.1	-	35.5	39.6	-	40/40
								11.3/15	31.3	36.1	-	48.6	54.6	-	50/60
								15/20	41.4	47.9	-	61.3	69.4	-	70/70
	460-3-60	414	506	6.2	41.0	0.5	3.8	-	-	-	-	-	-	12.1	15
								5	-	-	6.0	-	-	12.3	15
								10	-	-	12.0	-	-	19.8	20
								15	-	-	18.0	-	-	27.3	30
								20	-	-	24.1	-	-	34.9	35
60	208/230-3-60	197	253	16.0	110.0	1.2	7.6	-/-	-	-	-	28.8	28.8	-	40
								3.8/5	10.4	12.0	-	28.8	28.8	-	40/40
								7.5/10	20.8	24.1	-	35.5	39.6	-	40/40
								11.3/15	31.3	36.1	-	48.6	54.6	-	50/60
								15/20	41.4	47.9	-	61.3	69.4	-	70/70
	460-3-60	414	506	7.8	52.0	0.5	3.8	-	-	-	-	-	-	14.0	20
								5	-	-	6.0	-	-	14.0	20
								10	-	-	12.0	-	-	19.8	20
								15	-	-	18.0	-	-	27.3	30
								20	-	-	24.1	-	-	34.9	35

* kW @ 208/240 or 480 volts

** FUSE OR CIRCUIT BREAKER

Note: 460 volt units have 230 volt ID motors with FLA values at 230 volts

LEGEND

- FLA - Full Load Amps
- IDM - Inducer Motor
- IFM - Indoor Fan Motor
- LRA - Locked Rotor Amps
- MCA - Minimum Circuit Amps
- MOCP - Maximum Over Current Protection
- OFM - Outdoor Fan Motor
- RLA - Rated Load Amps

NOTES:

1. In compliance with NEC (National Electrical Code) requirements for multimotor and combination load equipment (refer to NEC Articles 430 and 440), the overcurrent protective device for the unit shall be Power Supply fuse or circuit breaker.
2. Minimum wire size is based on 60 C copper wire. If other than 60 C wire is used, or if length exceeds wire length in table, determine size from NEC.
3. Unbalanced 3-Phase Supply Voltage
Never operate a motor where a phase imbalance in supply voltage is greater than 2%. Use the following formula to determine the percentage of voltage imbalance

% Voltage imbalance

$$= 100 \times \frac{\text{max voltage deviation from average voltage}}{\text{average voltage}}$$

EXAMPLE: Supply voltage is 230-3-60.

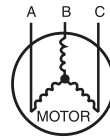

AB = 228 v
BC = 231 v
AC = 227 v

$$\begin{aligned} \text{Average Voltage} &= \frac{228 + 231 + 227}{3} \\ &= \frac{686}{3} \\ &= 229 \end{aligned}$$

Determine maximum deviation from average voltage.

(AB) 229 - 228 = 1 v
(BC) 231 - 229 = 2 v
(AC) 229 - 227 = 2 v

Maximum deviation is 2 v.

Determine percent of voltage imbalance

$$\begin{aligned} \% \text{ Voltage Imbalance} &= 100 \times \frac{2}{229} \\ &= 0.8\% \end{aligned}$$

This amount of phase imbalance is satisfactory as it is below the maximum allowable 2%.

IMPORTANT: If the supply voltage phase imbalance is more than 2%, contact your local electric utility company immediately.

A06564

50ES--A



CONNECTION WIRING SCHEMATIC 208/230-3-60

CONNECTION WIRING DIAGRAM

DANGER: ELECTRICAL SHOCK HAZARD DISCONNECT POWER BEFORE SERVICING

SCHEMATIC
230-3-60

50ES--A

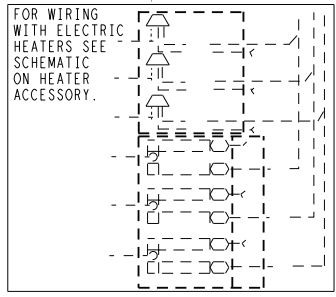
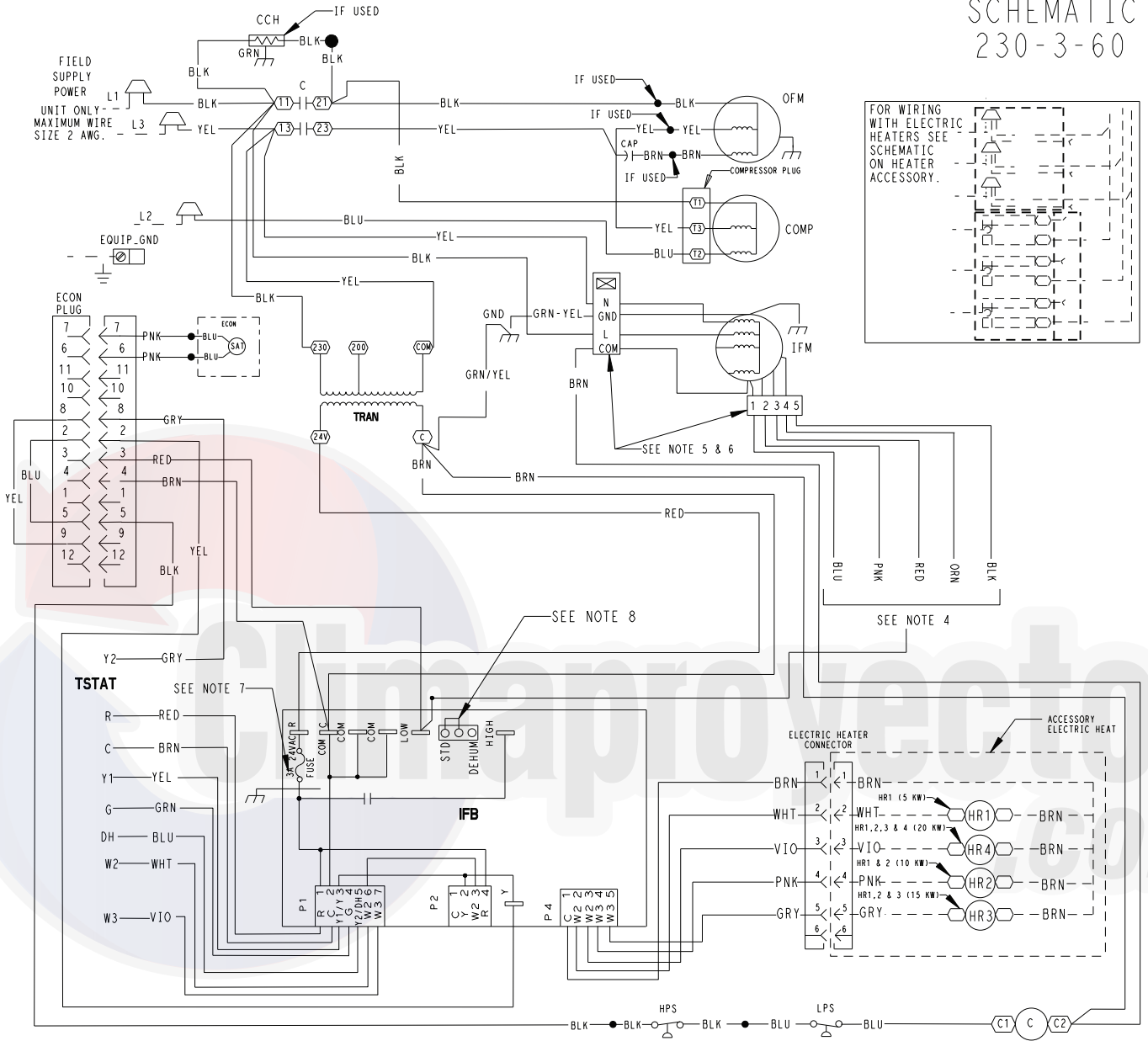

UNIT COMPONENT ARRANGEMENT

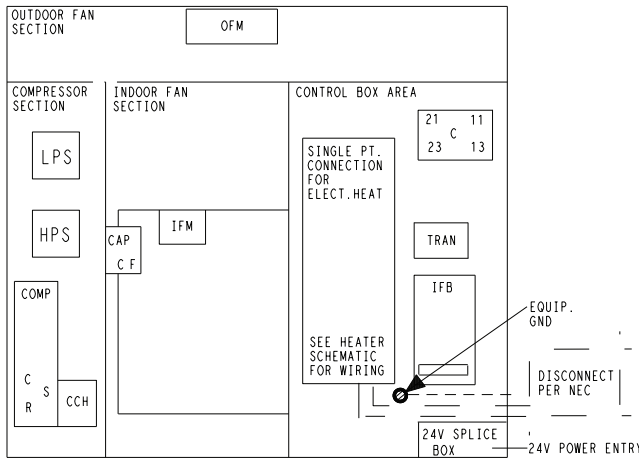

COLOR CODE

BLK	BLACK
BLU	BLUE
BRN	BROWN
GRY	GRAY
GRN	GREEN
ORN	ORANGE
PNK	PINK
RED	RED
VIO	VIOLET
WHT	WHITE
YEL	YELLOW

LEGEND

△	FIELD SPLICE	C	CONTACTOR
○	TERMINAL (MARKED) ENERGIZED	CAP	CAPACITOR
○	TERMINAL (UNMARKED)	CCH	CRANK CASE HEATER
●	SPLICE (IF USED)	COMP	COMPRESSOR MOTOR
○	SPLICE (MARKED)	DH	DEHUMIDIFICATION MODE
—	FACTORY WIRING	DEHUM	DEHUMIDIFICATION MODE
---	FIELD CONTROL WIRING	ECON	ECONOMIZER
---	FIELD POWER WIRING	GND	GROUND
---	ACCESSORY OR OPTIONAL WIRING	HPS	HIGH PRESSURE SWITCH
---	NOT TO REPRESENT WIRING	HR	HEATER RELAY
		IFB	INTERFACE FAN BOARD
		IFM	INDOOR FAN MOTOR
		LPS	LOW PRESSURE SWITCH
		OFM	OUTDOOR FAN MOTOR
		STD	STANDARD MODE
		TRAN	TRANSFORMER

NOTES:

- IF ANY OF THE ORIGINAL WIRES FURNISHED ARE REPLACED, THEY MUST BE REPLACED WITH THE SAME WIRE OR IT'S EQUIVALENT.
- SEE PRICE PAGES FOR THERMOSTATS.
- USE 75 DEGREE COPPER CONDUCTORS FOR FIELD INSTALLATION.
- REFER TO INSTALLATION INSTRUCTIONS FOR CORRECT SPEED SELECTION OF IFM.
- RELOCATION OF SPEED TAPS MAY BE REQUIRED WHEN USING FIELD INSTALLED ELECTRIC HEATERS. CONSULT INSTALLATION INSTRUCTIONS TO DETERMINE CORRECT SPEED TAP SETTING.
- DO NOT DISCONNECT PLUG UNDER LOAD.
- THIS FUSE IS MANUFACTURED BY LITTELFUSE, P/N 257003.
- DEHUM FEATURE CANNOT BE USED WHEN ECONOMIZER IS INSTALLED. UNIT FACTORY-SHIPED IN STD MODE.

LADDER WIRING SCHEMATIC 208/230-3-60

LADDER WIRING DIAGRAM

DANGER: ELECTRICAL SHOCK HAZARD DISCONNECT POWER BEFORE SERVICING

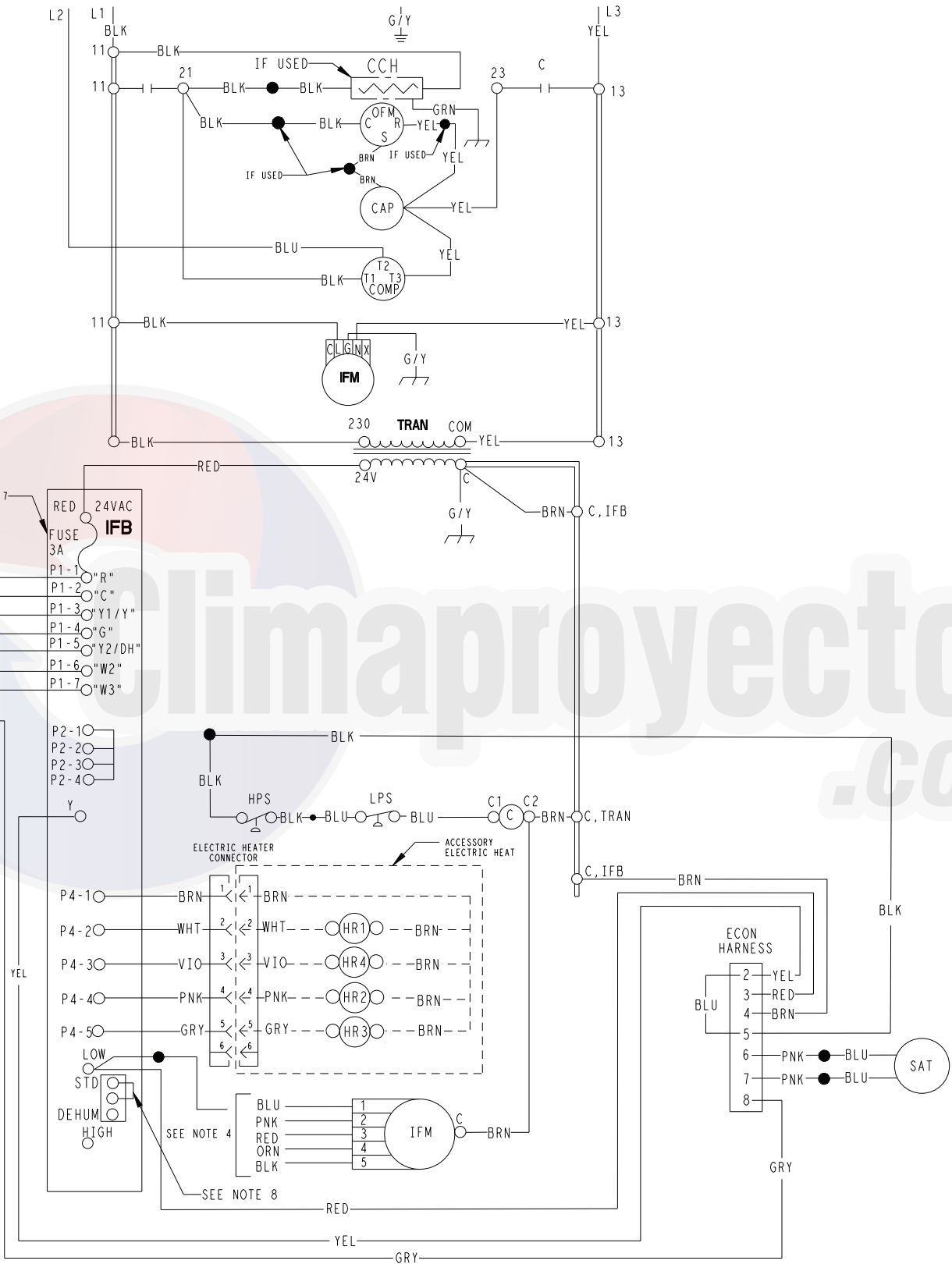

50VL500270

E

50ES--A

CONNECTION WIRING SCHEMATIC 460-3-60

CONNECTION WIRING DIAGRAM

DANGER: ELECTRICAL SHOCK HAZARD DISCONNECT POWER BEFORE SERVICING

SCHEMATIC
460-3-60

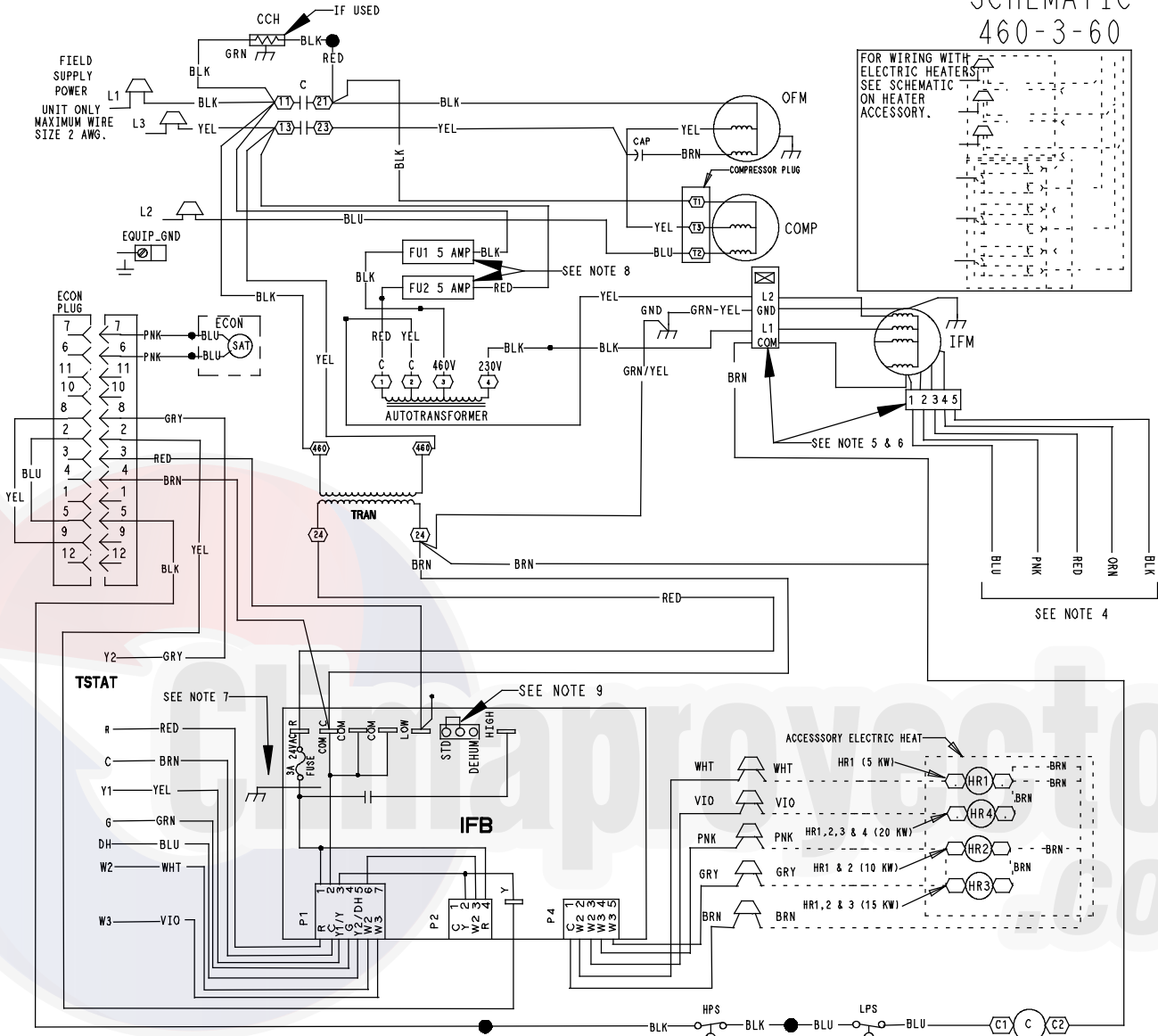

50ES--A

UNIT COMPONENT ARRANGEMENT

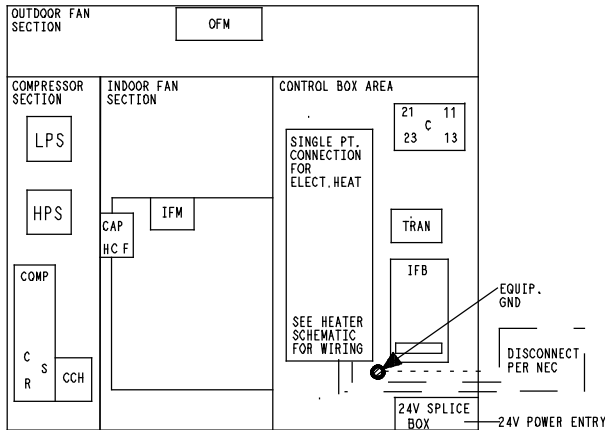

COLOR CODE		LEGEND	
BLK	BLACK	△	FIELD SPLICE
BLU	BLUE	○	TERMINAL (MARKED) ENERGIZED
BRN	BROWN	○	TERMINAL (UNMARKED)
BRN	BROWN	●	SPLICE (IF USED)
GRY	GRAY	○	SPLICE (MARKED)
GRN	GREEN	—	FACTORY WIRING
GRN	GREEN	---	FIELD CONTROL WIRING
ORN	ORANGE	---	FIELD POWER WIRING
PNK	PINK	- - -	ACCESSORY OR OPTIONAL WIRING
RED	RED	---	POTENTIAL ONLY
VIO	VIOLET	---	NOT TO REPRESENT WIRING
WHT	WHITE		
YEL	YELLOW		
		C	CONTACTOR
		CAP	CAPACITOR
		COMP	COMPRESSOR MOTOR
		CCH	CRANK CASE HEATER
		DH	DEHUMIDIFICATION MODE
		DEHUM	DEHUMIDIFICATION MODE
		ECON	ECONOMIZER
		GND	GROUND
		HPS	HIGH PRESSURE SWITCH
		IFB	INTERFACE FAN BOARD
		IFM	INDOOR FAN MOTOR
		LPS	LOW PRESSURE SWITCH
		OFM	OUTDOOR FAN MOTOR
		STD	STANDARD MODE
		TRAN	TRANSFORMER

- NOTES:
- IF ANY OF THE ORIGINAL WIRES FURNISHED ARE REPLACED, IT MUST BE REPLACED WITH TYPE 90 DEGREE C WIRE OR IT'S EQUIVALENT.
 - SEE PRICE PAGES FOR THERMOSTAT AND SUBBASES.
 - USE 75 DEGREE COPPER CONDUCTORS FOR FIELD INSTALLATION.
 - REFER TO INSTALLATION INSTRUCTIONS FOR CORRECT SPEED SELECTION OF IFM.
 - RELOCATION OF SPEED TAPS MAY BE REQUIRED WHEN USING FIELD INSTALLED ELECTRIC HEATERS. CONSULT INSTALLATION INSTRUCTIONS TO DETERMINE CORRECT SPEED TAP SETTING.
 - "DO NOT DISCONNECT PLUG UNDER LOAD."
 - THIS FUSE IS MANUFACTURED BY LITTELFUSE, P/N 257003
 - THESE FUSES ARE MANUFACTURED BY COOPER BUSSMAN, P/N FNQ-R-5
 - DEHUM FEATURE CANNOT BE USED WHEN ECONOMIZER IS INSTALLED.
 - UNIT FACTORY-SHIPED IN STD MODE.

LADDER WIRING SCHEMATIC 460-3-60

LADDER WIRING DIAGRAM

DANGER: ELECTRICAL SHOCK HAZARD DISCONNECT POWER BEFORE SERVICING

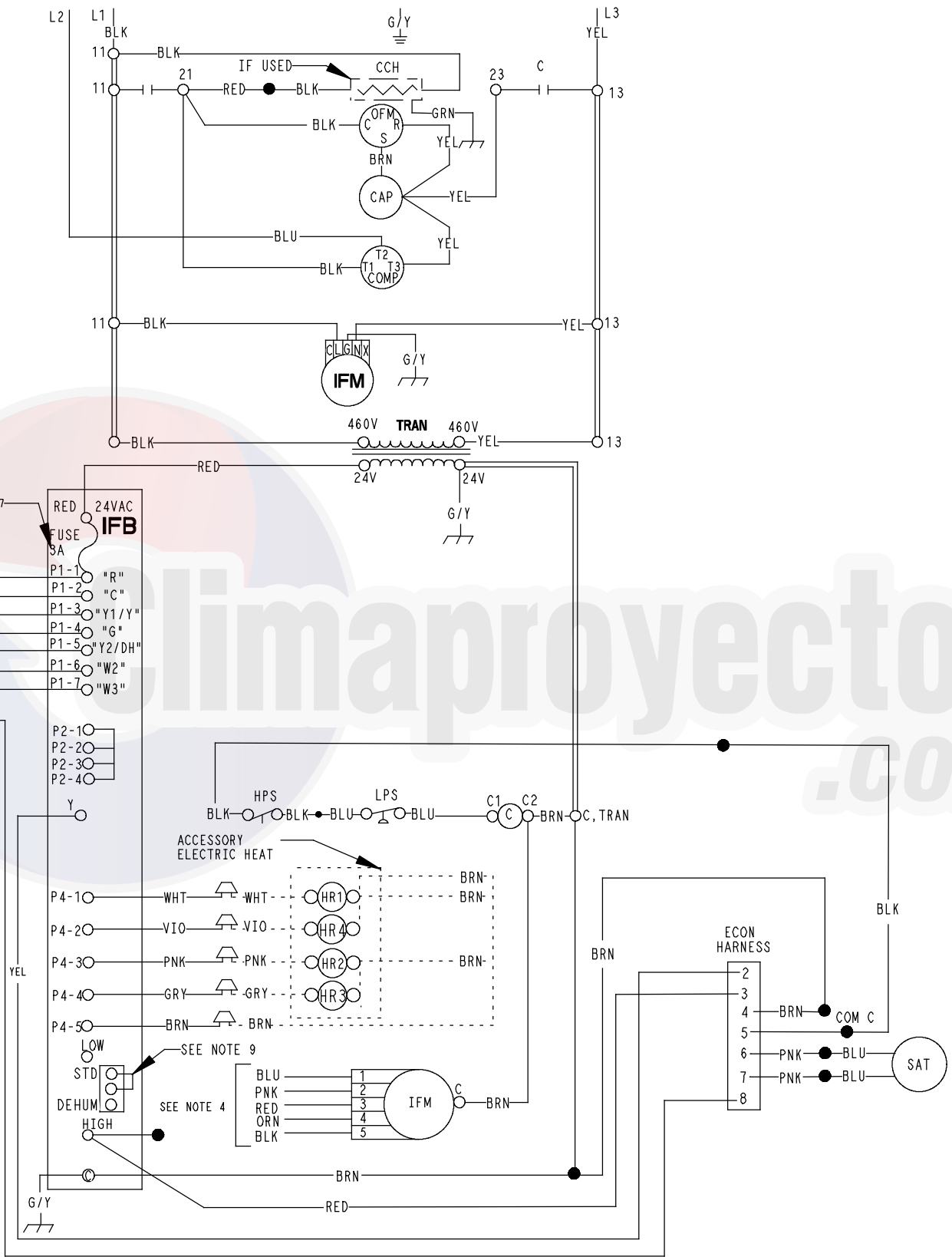

50ES--A

50VL500271 D

A10204

CONTROLS

Operating sequence

Cooling — When the system thermostat calls for cooling, 24 V is supplied to the “Y” and “G” terminals of the thermostat. This completes the circuit to the contactor coil (C) and indoor (evaporator) fan motor (IFM). The normally open contacts of C close and complete the circuit through compressor motor (COMP) to outdoor (condenser) fan motor (OFM). Both motors start instantly. Simultaneously, 24 volts is supplied through G to the Interface Fan Board (IFB) and to the IFM. The IFM starts instantly. On the loss of the thermostat call for cooling, 24 V is removed from both the “Y” and “G” terminals (provided the fan switch is in the “AUTO” position) de-energizing the compressor contactor and opening the contacts supplying power to compressor/OFM. After a 90-second delay, the IFM shuts off. If the thermostat fan selector switch is in the “ON” position, the IFM will run continuously. For the 460 V units there is a step down autotransformer supplying 230 V to the Indoor Fan Motor.

NOTE: On units with a Time Guard® II device: Once the compressor has started and then stopped, it cannot be restarted again until 5 minutes have elapsed.

Heating — If accessory electric heaters are installed, on a call for heat, circuit R-W is made through the thermostat contacts. Circuit R-G is made which energizes the IFM. If the heaters are staged, then the thermostat closes a second set of contacts (W2) when second stage is required. When thermostat is satisfied, contacts open, deenergizing the heater relay and the IFM.

50ES--A



GUIDE SPECIFICATIONS

Packaged Electric Cooling Unit Constant Volume Application HVAC Guide Specifications

Size Range: 2 1/2 to 5 Tons, Nominal Cooling

Model Number: 50ES

Part 1 — General

SYSTEM DESCRIPTION

Outdoor rooftop mounted or ground mounted, electric cooling unit utilizing a hermetic scroll compressor for cooling duty. Unit shall discharge supply air vertically or horizontally as shown on contract drawings. Condenser fan/coil section shall have a draw-thru design with vertical discharge for minimum sound levels.

QUALITY ASSURANCE

- A. Unit shall be rated in accordance with AHRI Standards 210/240 and 270-1995.
- B. Unit shall be designed in accordance with UL Standard 1995.
- C. Unit shall be manufactured in a facility registered to ISO 9001 manufacturing quality standard.
- D. Unit shall be UL listed and c-UL certified as a total package for safety requirements.
- E. Roof curb shall be designed to conform to NRCA Standards.
- F. Insulation and adhesives shall meet NFPA 90A requirements for flame spread and smoke generation.
- G. Cabinet insulation shall meet ASHRAE Standard 62P.

DELIVERY, STORAGE AND HANDLING

Unit shall be stored and handled per manufacturer's recommendations.

Part 2 — Products

EQUIPMENT

A. General:

Factory-assembled, single-piece, heating and cooling unit. Contained within the enclosure shall be all factory wiring, piping, controls, refrigerant charge with R-410A refrigerant, and special features required prior to field start-up.

B. Unit Cabinet:

- 1. Unit cabinet shall be constructed of phosphated, zinc-coated, pre-painted steel capable of with-standing 500 hours in salt spray.
- 2. Normal service shall be through a 3 removable cabinet panels.
- 3. The unit shall be constructed on a rust proof unit base that has an externally trapped, integrated sloped drain.
- 4. Evaporator fan compartment top surface shall be insulated with a minimum 1/2-in. (12.7 mm) thick, flexible fiberglass insulation, coated on the air side and retained by adhesive and mechanical means. The evaporator wall sections will be insulated with a minimum semi-rigid foil-faced board capable of being wiped clean. Aluminum foil-faced fiberglass insulation shall be used in the entire indoor air cavity section.
- 5. Unit shall have a field-supplied condensate trap.

C. Fans:

- 1. The evaporator fan motor shall be an ECM .
- 2. Fan wheel shall be made from steel, be double-inlet type with forward curved blades with corrosion resistant finish. Fan wheel shall be dynamically balanced.

- 3. Condenser fan shall be direct drive propeller type with aluminum blades riveted to corrosion resistant steel spiders, be dynamically balanced, and discharge air vertically.

D. Compressor:

- 1. Fully hermetic compressors with factory-installed vibration isolation.
- 2. Scroll compressors shall be standard on all units.

E. Coils:

Evaporator and condenser coils shall have aluminum plate fins mechanically bonded to seamless copper tubes with all joints brazed. Tube sheet openings shall be belled to prevent tube wear.

F. Refrigerant Components:

Refrigerant expansion device shall be of the TXV (thermostatic expansion valve) type.

G. Filters:

Filter section shall consist of field-installed, throwaway, 1-in. (25 mm) thick fiberglass filters of commercially available sizes.

H. Controls and Safeties:

- 1. Unit controls shall be complete with a self-contained low voltage control circuit.
- 2. Units shall incorporate high and low pressure switches.

I. Operating Characteristics:

- 1. Unit shall be capable of starting and running at 125°F (51°C) ambient outdoor temperature per maximum load criteria of AHRI Standard 210.
- 2. Compressor with standard controls shall be capable of operation down to 40°F (4°C) ambient outdoor temperature.
- 3. Unit shall be provided with 60-second fan time delay after the thermostat is satisfied.

J. Electrical Requirements:

All unit power wiring shall enter the unit cabinet at a single location.

K. Motors:

- 1. Compressor motors shall be of the refrigerant-cooled type with line-break thermal and current overload protection.
- 2. All fan motors shall have permanently lubricated bearings, and inherent, automatic reset, thermal overload protection.
- 3. Condenser fan motor shall be totally enclosed.
- 4. Evaporator fan motor to be ECM Motor.

L. Special Features:

- 1. Coil Options:
Base unit with tin plated indoor coil hairpins available as a factory installed option.
- 2. Thermostat:
To provide for one-stage heating and cooling in addition manual or automatic changeover and indoor fan control.
- 3. Crankcase Heater:
Shall provide anti-floodback protection for low-load cooling applications.
- 4. Economizer:
(Horizontal - Field installed accessory)
(Vertical - Field installed accessory or factory installed option)
 - a. Economizer controls capable of providing free cooling using outside air.
 - b. Equipped with low leakage dampers not to exceed 3% leakage, at 1.0 IN. W.C. pressure differential.
 - c. Spring return motor shuts off outdoor damper on power failure.

GUIDE SPECIFICATIONS (CONT)

5. Electric Heaters:

- a. Electric heater shall be available as a field-installed option.
- b. Heater elements shall be open wire type, adequately supported and insulated with ceramic bushings.
- c. Electric heater packages must provide single point power connection capability.

6. Filter Rack Kit:

Shall provide filter mounting for downflow applications. Offered as an accessory or as a factory installed option.

7. Flat Roof Curb:

Curbs shall have seal strip and a wood nailer for flashing and shall be installed per manufacturer's instructions.

8. Low Ambient Package:

Shall consist of a solid-state control and condenser coil temperature sensor for controlling condenser-fan motor operation, which shall allow unit to operate down to 0°F (-17°C) outdoor ambient temperature when properly installed.

9. Louvered Grille:

Wire grille shall be standard on all units. Louvered grille shall be available as a field-installed option to provide hail guard and vandalism protection.

10. Manual Outdoor Air Damper:

Package shall consist of damper, birdscreen, and rainhood which can be preset to admit outdoor air for year-round ventilation.

11. Square-To-Round Duct Transitions (30-48 size):

Shall have the ability to convert the supply and return openings from rectangular to round.

12. Time Guard II

Automatically prevents the compressor from restarting for at least 4 minutes and 45 seconds after shutdown of the compressor. Not required when a corporate programmable thermostat is applied or with a RTU-MP control.

13. Dual Point Electric Heater

Allows you to power the electric heater and unit contactor separately by having two individual field power supply circuits connected respectively.

50ES--A

