



Air Conditioning & Heating

PRODUCT SPECIFICATIONS



13 SEER

NOMINAL COOLING CAPACITY
18,000 TO 60,000 BTU/H

NOMINAL HEATING CAPACITY
17,200 TO 54,300 BTU/H

Residential



Commercial



GSH13

SPLIT SYSTEM HEAT PUMP

The Goodman® brand GSH13 heat pump features a louvered metal guard that protects the coil from damage and strengthens the unit. Designed for ground-level or rooftop mount, the unit has a base pan that elevates it above the slab for excellent water drainage.

Standard Features

- Energy-efficient compressor
- R-22 refrigerant-charged for 15' of refrigerant lines
- Quiet condenser fan system
- Copper tube/aluminum fin coil
- Liquid refrigerant return protection
- Factory-installed bi-flow liquid line filter dryer
- Low-pressure switch
- Time-initiated, temperature-terminated defrost control
- Service valves with sweat connections and easy-access gauge ports
- 13 SEER performance with flowrate expansion device
- Contactor with lug connection
- Ground lug connection
- ARI Certified; ETL Listed

Cabinet Features

- Unique louver design sound control top
- Steel louver coil guard
- Heavy-gauge, galvanized-steel cabinet with rust-resistant screws
- Attractive Architectural Gray powder-paint finish with 500-hour salt-spray approval
- Single-panel access to controls with space provided for field-installed accessories
- When properly anchored, meets the 2001 Florida Building Code unit integrity requirements for hurricane-type winds

Contents

Nomenclature.....	2
Product Specifications.....	3
Dimensions.....	5
Expanded Cooling Data.....	6
Expanded Heating Data.....	40
ARI Performance Ratings.....	44
Wiring Diagrams.....	66
Accessories	68



NOMENCLATURE

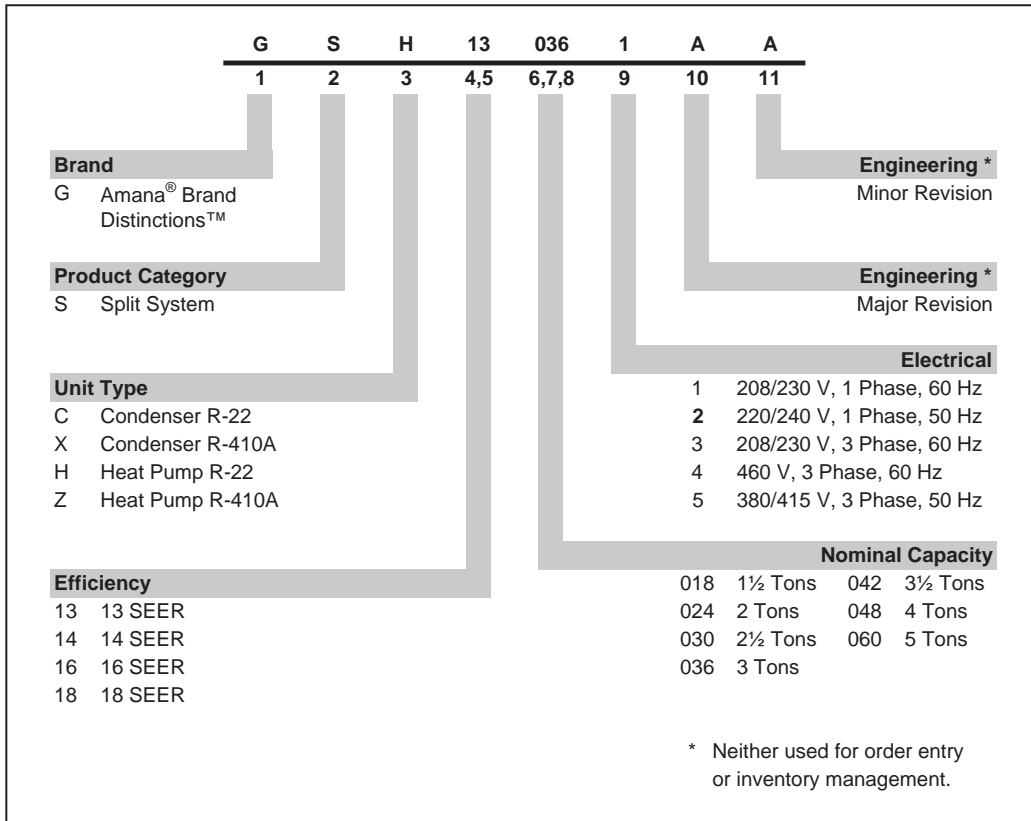

SPECIFICATIONS

	GSH13 0181AA	GSH13 0181BA	GSH13 0191AA	GSH13 0241AA	GSH13 0241BA	GSH13 0251AA	GSH13 0301AA	GSH13 0301BA	GSH13 0311AA	GSH13 0361AA
Capacities and Ratings										
Nominal Cooling (BTU/h)	18,000	18,000	18,000	23,000	23,000	23,000	28,000	28,000	28,000	35,000
Nominal Heating (BTU/h)	16,800	16,800	16,800	22,000	22,000	22,600	26,800	26,800	25,600	32,000
SEER	13	13	13	13	13	13	13	13	13	13
Decibels	78	74	78	78	78	78	78	74	76	80
Compressor										
RLA	6.2	6.2	9.0	9.2	9.2	10.9	10.8	10.8	12.2	12.2
LRA	34.0	35	41.0	43.0	43.0	54.0	60.0	60.0	63.0	73.0
Type	Recip	Recip	Scroll	Recip	Recip	Scroll	Recip	Recip	Scroll	Recip
Condenser Fan Motor										
Horsepower	1/6	1/6	1/6	1/6	1/6	1/6	1/6	1/6	1/6	¼
FLA	1.5	1.1	1.5	1.5	1.1	1.5	1.5	1.1	1.5	1.5
Refrigerant System										
Refrigerant Line Size ¹										
Liquid Line Size ("O.D.)	3/8"	3/8"	3/8"	3/8"	3/8"	3/8"	3/8"	3/8"	3/8"	3/8"
Suction Line Size ("O.D.)	3/4"	3/4"	3/4"	3/4"	3/4"	3/4"	3/4"	3/4"	3/4"	7/8"
Refrigerant Connection Size										
Liquid Valve Size ("O.D.)	3/8"	3/8"	3/8"	3/8"	3/8"	3/8"	3/8"	3/8"	3/8"	3/8"
Suction Valve Size ("O.D.)	3/4"	3/4"	3/4"	3/4"	3/4"	3/4"	3/4"	3/4"	3/4"	7/8"
Valve Type	Sweat	Sweat	Sweat	Sweat	Sweat	Sweat	Sweat	Sweat	Sweat	Sweat
Refrigerant Charge	127	127	115	106	122	117	153	130	153	188
Shipped with Orifice Size	0.052	0.055	0.052	0.061	0.061	0.061	0.068	0.070	0.065	0.073
Electrical Data										
AC Volts	208/230	208/230	208/230	208/230	208/230	208/230	208/230	208/230	208/230	208/230
Voltage-Phase-Frequency	60 Hz/1	60 Hz/1	60 Hz/1	60 Hz/1	60 Hz/1	60 Hz/1	60 Hz/1	60 Hz/1	60 Hz/1	60 Hz/1
Minimum Circuit Ampacity ²	9.3	8.9	12.7	13.0	12.6	15.1	15.0	14.6	16.7	16.9
Max. Overcurrent Protection ³	15	15	20	20	20	20	20	20	20	20
Min / Max Volts	197/253	197/253	197/253	197/253	197/253	197/253	197/253	197/253	197/253	197/253
Electrical Conduit Size	1/2" or 3/4"	1/2" or 3/4"	1/2" or 3/4"	1/2" or 3/4"	1/2" or 3/4"	1/2" or 3/4"	1/2" or 3/4"	1/2" or 3/4"	1/2" or 3/4"	1/2" or 3/4"
Ship Weight (lbs)	193	169	193	198	177	207	199	185	199	207

¹ Tested and rated in accordance with ARI Standard 210/240

² Wire size should be determined in accordance with National Electrical Codes; extensive wire runs will require larger wire sizes

³ Must use time-delay fuses or HACR-type circuit breakers of the same size as noted.

Notes

- Always check the S&R plate for electrical data on the unit being installed.
- Installer will need to supply 7/8" to 1 1/8" adapters for suction line connections.
- Unit is charged with refrigerant for 15' of 3/8" liquid line. System charge must be adjusted per Installation Instructions Final Charge Procedure.
- Installation of these units requires the specified TXV Kit to be installed on the indoor coil. THE SPECIFIED TXV IS DETERMINED BY THE OUTDOOR UNIT NOT THE INDOOR COIL.

SPECIFICATIONS

	GSH13 0361BA	GSH13 0361BB	GSH13 0363AA	GSH13 0421AA	GSH13 0481AA	GSH13 0483AA	GSH13 0484AA	GSH13 0601AA	GSH13 0603AA	GSH13 0604AA
Nominal Capacities										
Cooling (BTU/h)	35,000	35,000	35,000	40,000	45,000	45,000	45,000	55,500	55,500	55,500
Heating (BTU/h)	32,000	32,000	32,000	39,000	43,000	43,000	43,000	55,500	55,500	55,500
SEER	13	13	13	13	13	13	13	13	13	13
Deci bels	80	80	80	76	76	76	76	77	77	77
Compressor										
RLA	12.2	12.2	9.0	16.5	17.9	12.4	5.8	25.0	17.3	6.7
LRA	73.0	73.0	65.5	95.0	104.0	88.0	44.0	148.0	123.0	49.5
Type	Recip	Recip	Recip	Scroll	Scroll	Scroll	Scroll	Scroll	Scroll	Scroll
Condenser Fan Motor										
Horsepower	¼	¼	¼	¼	¼	¼	¼	1/6	1/6	1/6
FLA	1.5	1.5	1.6	1.6	1.6	1.6	0.8	1.1	1.1	0.6
Refrigeration System										
Refrigerant Line Size ¹										
Liquid Line Size ("O.D.)	⅜"	⅜"	⅜"	⅜"	⅜"	⅜"	⅜"	⅜"	⅜"	⅜"
Suction Line Size ("O.D.)	7/8"	7/8"	1 1/8"	1 1/8"	1 1/8"	1 1/8"	1 1/8"	1 1/8"	1 1/8"	1 1/8"
Refrigerant Connection Size										
Liquid Valve Size ("O.D.)	⅜"	⅜"	⅜"	⅜"	⅜"	⅜"	⅜"	⅜"	⅜"	⅜"
Suction Valve Size ("O.D.)	7/8"	7/8"	7/8"	7/8"	7/8"	7/8"	7/8"	7/8"	7/8"	7/8"
Valve Type	Sweat	Sweat	Sweat	Sweat	Sweat	Sweat	Sweat	Sweat	Sweat	Sweat
Refrigerant Charge	188	188	188	213	223	223	223	233	233	233
Shipped with Orifice Size	0.073	0.073	0.073	0.082	0.084	0.084	0.084	0.093	0.093	0.093
Electrical Data										
AC Volts	208/230	208/230	208/230	208/230	208/230	208/230	460	208/230	208/230	460
Hz / Phase	60 Hz/1	60 Hz/1	60 Hz/3	60 Hz/1	60 Hz/1	60 Hz/3	60 Hz/3	60 Hz/1	60 Hz/3	60 Hz/3
Minimum Circuit Ampacity ²	17.0	17.0	12.0	22.3	27.8	17.2	8.0	32.3	22.7	9.0
Max. Overcurrent Protection ³	25	25	20	30	40	20	15	50	40	15
Min / Max Volts	197/253	197/253	197/253	197/253	197/253	197/253	414/506	197/253	197/253	414/506
Electrical Conduit Size	½" or ¾"	½" or ¾"	½" or ¾"	½" or ¾"	½" or ¾"	½" or ¾"	½" or ¾"	½" or ¾"	½" or ¾"	½" or ¾"
Ship Weight (lbs)	207	207	207	219	225	225	225	266	266	266

¹ Tested and rated in accordance with ARI Standard 210/240

² Wire size should be determined in accordance with National Electrical Codes; extensive wire runs will require larger wire sizes

³ Must use time-delay fuses or HACR-type circuit breakers of the same size as noted.

Notes

- Always check the S&R plate for electrical data on the unit being installed.
- Installer will need to supply 7/8" to 1 1/8" adapters for suction line connections.
- Unit is charged with refrigerant for 15' of 3/8" liquid line. System charge must be adjusted per Installation Instructions Final Charge Procedure.
- Installation of these units requires the specified TXV Kit to be installed on the indoor coil. THE SPECIFIED TXV IS DETERMINED BY THE OUTDOOR UNIT NOT THE INDOOR COIL.

DIMENSIONS

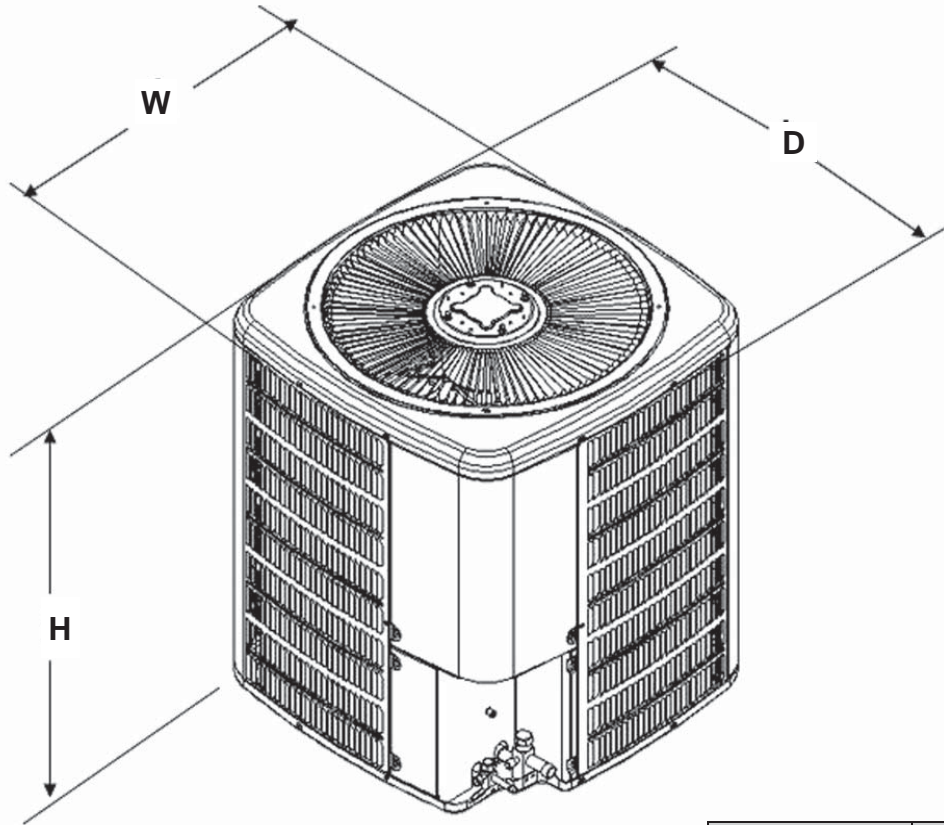

Model	Dimensions		
	W"	D"	H"
GSH130181A	29	29	32¼
GSH130181B	26	26	32¼
GSH130191A	29	29	32¼
GSH130241A	29	29	34¾
GSH130241B	26	26	32¼
GSH130251A	29	29	34¾
GSH130301A	29	29	34¾
GSH130301B	26	26	34¾
GSH130311A	29	29	34¾
GSH130361A	29	29	38¼
GSH130361B	29	29	38¼
GSH130363A	29	29	38¼
GSH130421A	29	29	32¼
GSH130481A	29	29	34¾
GSH130483A	29	29	34¾
GSH130484A	29	29	34¾
GSH130601A	35½	35½	34¾
GSH130603A	35½	35½	34¾
GSH130604A	35½	35½	34¾

EXPANDED COOLING DATA — GSH130181A* / ARUF32-00*-1* / ARUF18241A*

IDB	Airflow	Outdoor Ambient Temperature																								
		65°F				75°F				85°F				95°F				105°F				115°F				
		59	63	67	71	59	63	67	71	59	63	67	71	59	63	67	71	59	63	67	71	59	63	67	71	
70	675	MBh	17.6	18.3	20.0	-	17.2	17.9	19.6	-	16.8	17.4	19.1	-	16.4	17.0	18.6	-	15.6	16.2	17.7	-	14.4	15.0	16.4	-
		S/T	0.74	0.62	0.43	-	0.76	0.64	0.44	-	0.78	0.65	0.45	-	0.81	0.67	0.47	-	0.84	0.70	0.49	-	0.85	0.71	0.49	-
	ΔT	18	15	12	-	18	16	12	-	18	16	12	-	18	16	12	-	18	15	12	-	17	14	11	-	
	kW	1.26	1.29	1.33	-	1.36	1.39	1.43	-	1.44	1.47	1.52	-	1.51	1.55	1.59	-	1.57	1.61	1.66	-	1.63	1.66	1.72	-	
	Amps	4.8	4.9	5.1	-	5.2	5.3	5.5	-	5.6	5.7	5.9	-	6.0	6.1	6.3	-	6.4	6.5	6.7	-	6.7	6.9	7.1	-	
	Hi-PR	137	147	156	-	154	165	175	-	175	188	199	-	199	214	226	-	224	241	255	-	248	266	281	-	
	Lo-PR	63	67	73	-	66	70	77	-	69	73	80	-	72	77	84	-	76	81	88	-	78	83	91	-	
	MBh	17.1	17.7	19.4	-	16.7	17.3	19.0	-	16.3	16.9	18.5	-	15.9	16.5	18.1	-	15.1	15.7	17.2	-	14.0	14.5	15.9	-	
	S/T	0.70	0.59	0.41	-	0.73	0.61	0.42	-	0.75	0.62	0.43	-	0.77	0.64	0.45	-	0.80	0.67	0.46	-	0.81	0.67	0.47	-	
	ΔT	18	16	12	-	19	16	12	-	19	16	12	-	19	16	12	-	19	16	12	-	17	15	11	-	
kW	1.26	1.28	1.32	-	1.35	1.38	1.42	-	1.43	1.46	1.50	-	1.50	1.53	1.58	-	1.56	1.60	1.65	-	1.61	1.65	1.70	-		
Amps	4.8	4.9	5.0	-	5.1	5.2	5.4	-	5.6	5.7	5.9	-	5.9	6.1	6.3	-	6.3	6.4	6.7	-	6.7	6.8	7.1	-		
Hi-PR	136	146	154	-	152	164	173	-	173	186	197	-	197	212	224	-	222	239	252	-	245	264	279	-		
Lo-PR	62	66	72	-	66	70	76	-	68	72	79	-	72	76	83	-	75	80	87	-	78	83	90	-		
MBh	15.8	16.4	17.9	-	15.4	16.0	17.5	-	15.1	15.6	17.1	-	14.7	15.2	16.7	-	14.0	14.5	15.9	-	12.9	13.4	14.7	-		
S/T	0.68	0.57	0.39	-	0.70	0.59	0.41	-	0.72	0.60	0.42	-	0.74	0.62	0.43	-	0.77	0.64	0.45	-	0.78	0.65	0.45	-		
ΔT	19	16	12	-	19	16	12	-	19	16	12	-	19	17	13	-	19	16	12	-	18	15	12	-		
kW	1.23	1.25	1.29	-	1.32	1.34	1.38	-	1.40	1.42	1.47	-	1.47	1.50	1.54	-	1.52	1.56	1.61	-	1.58	1.61	1.66	-		
Amps	4.6	4.7	4.9	-	5.0	5.1	5.3	-	5.4	5.5	5.7	-	5.8	5.9	6.1	-	6.1	6.3	6.5	-	6.5	6.6	6.9	-		
Hi-PR	132	142	150	-	148	159	168	-	168	181	191	-	191	206	217	-	215	232	245	-	238	256	270	-		
Lo-PR	60	64	70	-	64	68	74	-	66	70	77	-	69	74	81	-	73	77	84	-	75	80	87	-		

75	675	MBh	17.9	18.5	20.0	21.5	17.5	18.0	19.5	21.0	17.1	17.6	19.1	20.5	16.7	17.2	18.6	20.0	15.9	16.3	17.7	19.0	14.7	15.1	16.4	17.6
		S/T	0.84	0.75	0.57	0.36	0.87	0.78	0.59	0.38	0.89	0.80	0.60	0.39	0.92	0.82	0.62	0.40	0.95	0.85	0.65	0.42	0.96	0.86	0.65	0.42
	ΔT	20	19	15	11	21	19	16	11	21	19	16	11	21	19	16	11	21	19	16	11	21	19	15	10	
	kW	1.27	1.30	1.34	1.38	1.37	1.40	1.44	1.49	1.45	1.48	1.53	1.58	1.53	1.56	1.61	1.66	1.59	1.62	1.67	1.73	1.64	1.68	1.73	1.79	
	Amps	4.8	4.9	5.1	5.3	5.2	5.3	5.5	5.7	5.7	5.8	6.0	6.2	6.0	6.2	6.4	6.6	6.4	6.6	6.8	7.0	6.8	7.0	7.2	7.5	
	Hi-PR	138	149	157	164	155	167	177	184	177	190	201	209	201	217	229	238	226	244	257	268	250	269	284	296	
	Lo-PR	63	67	74	78	67	71	78	83	70	74	81	86	73	78	85	90	77	81	89	95	79	84	92	98	
	MBh	17.4	17.9	19.4	20.8	17.0	17.5	19.0	20.3	16.6	17.1	18.5	19.9	16.2	16.7	18.1	19.4	15.4	15.8	17.2	18.4	14.3	14.7	15.9	17.1	
	S/T	0.80	0.71	0.54	0.35	0.83	0.74	0.56	0.36	0.85	0.76	0.57	0.37	0.88	0.78	0.59	0.38	0.91	0.81	0.62	0.40	0.92	0.82	0.62	0.40	
	ΔT	21	20	16	11	22	20	16	11	22	20	16	11	22	20	16	11	21	20	16	11	20	18	15	10	
kW	1.27	1.29	1.33	1.37	1.36	1.39	1.43	1.47	1.44	1.47	1.52	1.57	1.51	1.55	1.59	1.65	1.58	1.61	1.66	1.71	1.63	1.66	1.72	1.77		
Amps	4.8	4.9	5.1	5.2	5.2	5.3	5.5	5.7	5.6	5.7	5.9	6.1	6.0	6.1	6.3	6.6	6.4	6.5	6.7	7.0	6.7	6.9	7.1	7.4		
Hi-PR	137	147	156	162	154	166	175	182	175	188	199	207	199	214	226	236	224	241	255	266	248	266	281	293		
Lo-PR	63	67	73	78	66	70	77	82	69	73	80	85	72	77	84	89	76	81	88	94	78	83	91	97		
MBh	16.1	16.5	17.9	19.2	15.7	16.2	17.5	18.8	15.3	15.8	17.1	18.3	15.0	15.4	16.7	17.9	14.2	14.6	15.8	17.0	13.2	13.5	14.7	15.7		
S/T	0.77	0.69	0.52	0.34	0.80	0.71	0.54	0.35	0.82	0.73	0.55	0.36	0.84	0.76	0.57	0.37	0.88	0.78	0.59	0.38	0.88	0.79	0.60	0.38		
ΔT	22	20	16	11	22	20	17	11	22	20	17	11	22	20	17	12	22	20	16	11	20	19	15	11		
kW	1.24	1.26	1.30	1.34	1.33	1.35	1.40	1.44	1.41	1.44	1.48	1.53	1.48	1.51	1.56	1.61	1.54	1.57	1.62	1.67	1.59	1.62	1.68	1.73		
Amps	4.7	4.8	4.9	5.1	5.0	5.1	5.3	5.5	5.5	5.6	5.8	6.0	5.8	6.0	6.2	6.4	6.2	6.3	6.5	6.8	6.5	6.7	6.9	7.2		
Hi-PR	133	143	151	158	149	161	170	177	170	183	193	201	193	208	220	229	217	234	247	258	240	258	273	285		
Lo-PR	61	65	71	75	64	68	75	79	67	71	78	83	70	75	81	87	73	78	85	91	76	81	88	94		

IDB: Entering Indoor Dry Bulb Temperature kW = Total system power Shaded area reflects ACCA (TVA) conditions Amps = outdoor unit amps (comp.+fan)
 High and low pressures are measured at the liquid and suction service valves. Design Subcooling 9 ±3 °F @ the liquid service valve, ARI 95 test conditions

EXPANDED COOLING DATA — GSH130181A* / ARUF32-00*-1* / ARUF18241A* (CONT.)

IDB	Airflow	Outdoor Ambient Temperature																							
		65°F				75°F				85°F				95°F				105°F				115°F			
		59	63	67	71	59	63	67	71	59	63	67	71	59	63	67	71	59	63	67	71	59	63	67	71
80	MBh	18.3	18.7	19.9	21.3	17.8	18.2	19.5	20.8	17.4	17.8	19.0	20.3	17.0	17.4	18.5	19.8	16.1	16.5	17.6	18.8	14.9	15.3	16.3	17.4
	S/T	0.92	0.86	0.70	0.52	0.95	0.89	0.73	0.54	1.00	0.92	0.74	0.56	1.00	0.94	0.77	0.57	1.00	1.00	0.80	0.60	1.00	1.00	0.80	0.60
	ΔT	23	22	19	15	23	22	19	15	24	22	19	15	23	22	19	16	22	22	19	15	20	21	18	14
	kW	1.28	1.31	1.35	1.39	1.38	1.41	1.45	1.50	1.46	1.49	1.54	1.59	1.54	1.57	1.62	1.67	1.60	1.64	1.69	1.74	1.66	1.69	1.75	1.80
	Amps	4.9	5.0	5.2	5.3	5.3	5.4	5.6	5.8	5.7	5.8	6.0	6.3	6.1	6.2	6.4	6.7	6.5	6.6	6.8	7.1	6.9	7.0	7.2	7.5
	Hi PR	140	150	159	166	157	169	178	186	178	192	203	211	203	219	231	241	229	246	260	271	253	272	287	299
	Lo PR	64	68	74	79	68	72	78	84	70	75	82	87	74	78	86	91	77	82	90	96	80	85	93	99
	MBh	17.7	18.1	19.4	20.7	17.3	17.7	18.9	20.2	16.9	17.3	18.5	19.7	16.5	16.8	18.0	19.2	15.7	16.0	17.1	18.3	14.5	14.8	15.8	16.9
	S/T	0.88	0.82	0.67	0.50	0.91	0.85	0.69	0.52	0.93	0.87	0.71	0.53	0.96	0.90	0.73	0.55	1.00	0.94	0.76	0.57	1.00	0.94	0.77	0.57
	ΔT	24	23	20	16	24	23	20	16	24	23	20	16	24	23	20	16	24	23	20	16	22	21	19	15
kW	1.27	1.30	1.34	1.38	1.37	1.40	1.44	1.49	1.45	1.48	1.53	1.58	1.53	1.56	1.61	1.66	1.59	1.62	1.67	1.73	1.64	1.68	1.73	1.79	
Amps	4.8	4.9	5.1	5.3	5.2	5.3	5.5	5.7	5.7	5.8	6.0	6.2	6.0	6.2	6.4	6.6	6.4	6.6	6.8	7.0	6.8	7.0	7.2	7.5	
Hi PR	138	149	157	164	155	167	177	184	177	190	201	209	201	217	229	239	226	244	257	268	250	269	284	296	
Lo PR	63	67	74	78	67	71	78	83	70	74	81	86	73	78	85	90	77	81	89	95	79	84	92	98	
MBh	16.4	16.7	17.9	19.1	16.0	16.3	17.4	18.6	15.6	15.9	17.0	18.2	15.2	15.6	16.6	17.8	14.5	14.8	15.8	16.9	13.4	13.7	14.6	15.6	
S/T	0.84	0.79	0.64	0.48	0.88	0.82	0.67	0.50	0.90	0.84	0.69	0.51	0.93	0.87	0.71	0.53	0.96	0.90	0.73	0.55	0.97	0.91	0.74	0.55	
ΔT	24	23	20	16	24	23	20	16	25	23	20	16	25	24	21	16	24	23	20	16	23	22	19	15	
kW	1.25	1.27	1.31	1.35	1.34	1.36	1.41	1.45	1.42	1.45	1.49	1.54	1.49	1.52	1.57	1.62	1.55	1.58	1.63	1.69	1.60	1.64	1.69	1.74	
Amps	4.7	4.8	5.0	5.1	5.1	5.2	5.4	5.6	5.5	5.6	5.8	6.0	5.9	6.0	6.2	6.4	6.2	6.4	6.6	6.8	6.6	6.8	7.0	7.2	
Hi PR	134	145	153	159	151	162	171	179	171	184	195	203	195	210	222	231	220	236	250	260	243	261	276	288	
Lo PR	61	65	71	76	65	69	75	80	67	72	78	83	71	75	82	88	74	79	86	92	77	82	89	95	

85	MBh	18.6	18.9	19.8	21.2	18.1	18.5	19.4	20.7	17.7	18.1	18.9	20.2	17.3	17.6	18.4	19.7	16.4	16.7	17.5	18.7	15.2	15.5	16.2	17.3
	S/T	0.96	0.93	0.84	0.68	1.00	0.96	0.87	0.70	1.00	0.99	0.89	0.72	1.00	1.00	0.92	0.75	1.00	1.00	0.95	0.77	1.00	1.00	0.96	0.78
	ΔT	24	24	23	20	25	24	23	20	24	24	23	20	24	24	23	20	22	23	23	20	21	21	21	18
	kW	1.29	1.32	1.36	1.40	1.39	1.42	1.46	1.51	1.48	1.51	1.55	1.60	1.55	1.58	1.63	1.69	1.61	1.65	1.70	1.76	1.67	1.71	1.76	1.82
	Amps	4.9	5.0	5.2	5.4	5.3	5.4	5.6	5.8	5.8	5.9	6.1	6.3	6.1	6.3	6.5	6.7	6.5	6.7	6.9	7.2	6.9	7.1	7.3	7.6
	Hi PR	141	152	160	167	158	171	180	188	180	194	205	214	205	221	233	243	231	249	262	274	255	275	290	302
	Lo PR	65	69	75	80	68	73	79	84	71	75	82	88	74	79	87	92	78	83	91	97	81	86	94	100
	MBh	18.0	18.4	19.3	20.5	17.6	18.0	18.8	20.1	17.2	17.5	18.4	19.6	16.8	17.1	17.9	19.1	15.9	16.2	17.0	18.2	14.8	15.0	15.8	16.8
	S/T	0.92	0.89	0.80	0.65	0.95	0.92	0.83	0.67	0.98	0.94	0.85	0.69	1.00	0.97	0.88	0.71	1.00	1.00	0.91	0.74	1.00	1.00	0.92	0.74
	ΔT	25	25	24	20	26	25	24	21	26	25	24	21	26	25	24	21	24	25	24	21	23	23	22	19
kW	1.28	1.31	1.35	1.39	1.38	1.41	1.45	1.50	1.46	1.49	1.54	1.59	1.54	1.57	1.62	1.67	1.60	1.64	1.69	1.74	1.66	1.69	1.75	1.80	
Amps	4.9	5.0	5.2	5.3	5.3	5.4	5.6	5.8	5.7	5.8	6.0	6.3	6.1	6.2	6.4	6.7	6.5	6.6	6.8	7.1	6.9	7.0	7.2	7.5	
Hi PR	140	150	159	166	157	169	178	186	178	192	203	211	203	219	231	241	229	246	260	271	253	272	287	299	
Lo PR	64	68	74	79	68	72	78	84	70	75	82	87	74	78	86	91	77	82	90	96	80	85	93	99	
MBh	16.6	17.0	17.8	19.0	16.3	16.6	17.4	18.5	15.9	16.2	16.9	18.1	15.5	15.8	16.5	17.6	14.7	15.0	15.7	16.8	13.6	13.9	14.5	15.5	
S/T	0.89	0.85	0.77	0.63	0.92	0.89	0.80	0.65	0.94	0.91	0.82	0.66	0.97	0.94	0.85	0.69	1.00	0.97	0.88	0.71	1.00	0.98	0.89	0.72	
ΔT	26	25	24	21	26	26	24	21	26	26	24	21	26	26	24	21	26	26	24	21	24	24	23	20	
kW	1.26	1.28	1.32	1.36	1.35	1.38	1.42	1.46	1.43	1.46	1.50	1.55	1.50	1.53	1.58	1.63	1.56	1.60	1.65	1.70	1.61	1.65	1.70	1.76	
Amps	4.7	4.9	5.0	5.2	5.1	5.2	5.4	5.6	5.6	5.7	5.9	6.1	5.9	6.1	6.3	6.5	6.3	6.4	6.7	6.9	6.7	6.8	7.0	7.3	
Hi PR	136	146	154	161	152	164	173	180	173	186	197	205	197	212	224	234	222	239	252	263	245	264	278	290	
Lo PR	62	66	72	77	66	70	76	81	68	72	79	84	72	76	83	88	75	80	87	93	78	83	90	96	

IDB: Entering Indoor Dry Bulb Temperature kW = Total system power Shaded area reflects ARI Rating conditions Amps = outdoor unit amps (comp.+fan)
 High and low pressures are measured at the liquid and suction service valves. Design Subcooling 9 ±3 °F @ the liquid service valve, ARI 95 test conditions

EXPANDED COOLING DATA — GSH130181B* / AR*F182416**

IDB	Airflow	Outdoor Ambient Temperature																								
		65°F				75°F				85°F				95°F				105°F				115°F				
		59	63	67	71	59	63	67	71	59	63	67	71	59	63	67	71	59	63	67	71	59	63	67	71	
70	731	MBh	17.6	18.3	20.0	-	17.2	17.9	19.6	-	16.8	17.4	19.1	-	16.4	17.0	18.6	-	15.6	16.2	17.7	-	14.4	15.0	16.4	-
		S/T	0.72	0.60	0.42	-	0.75	0.63	0.43	-	0.77	0.64	0.44	-	0.79	0.66	0.46	-	0.82	0.69	0.48	-	0.83	0.69	0.48	-
	ΔT	16	14	11	-	16	14	11	-	16	14	11	-	16	14	11	-	16	14	11	-	15	13	10	-	
	kW	1.24	1.26	1.30	-	1.33	1.35	1.40	-	1.41	1.43	1.48	-	1.48	1.51	1.55	-	1.53	1.57	1.61	-	1.58	1.62	1.67	-	
	Amps	4.7	4.8	4.9	-	5.0	5.1	5.3	-	5.4	5.6	5.8	-	5.8	5.9	6.1	-	6.2	6.3	6.5	-	6.5	6.7	6.9	-	
	Hi PR	135	146	154	-	152	164	173	-	173	186	196	-	197	212	224	-	221	238	252	-	245	263	278	-	
	Lo PR	63	67	73	-	66	71	77	-	69	73	80	-	72	77	84	-	76	81	88	-	79	84	91	-	
	MBh	17.1	17.7	19.4	-	16.7	17.3	19.0	-	16.3	16.9	18.5	-	15.9	16.5	18.1	-	15.1	15.7	17.2	-	14.0	14.5	15.9	-	
	S/T	0.69	0.58	0.40	-	0.71	0.60	0.41	-	0.73	0.61	0.42	-	0.76	0.63	0.44	-	0.79	0.66	0.45	-	0.79	0.66	0.46	-	
	ΔT	17	14	11	-	17	15	11	-	17	15	11	-	17	15	11	-	17	15	11	-	16	14	10	-	
kW	1.23	1.25	1.29	-	1.32	1.34	1.38	-	1.40	1.42	1.47	-	1.46	1.49	1.54	-	1.52	1.55	1.60	-	1.57	1.61	1.66	-		
Amps	4.6	4.7	4.9	-	5.0	5.1	5.3	-	5.4	5.5	5.7	-	5.8	5.9	6.1	-	6.1	6.3	6.5	-	6.5	6.6	6.9	-		
Hi PR	134	144	152	-	150	162	171	-	171	184	194	-	195	210	221	-	219	236	249	-	242	261	275	-		
Lo PR	62	66	72	-	66	70	76	-	68	73	79	-	72	76	83	-	75	80	87	-	78	83	90	-		
MBh	15.8	16.4	17.9	-	15.4	16.0	17.5	-	15.1	15.6	17.1	-	14.7	15.2	16.7	-	14.0	14.5	15.9	-	12.9	13.4	14.7	-		
S/T	0.67	0.56	0.38	-	0.69	0.58	0.40	-	0.71	0.59	0.41	-	0.73	0.61	0.42	-	0.76	0.63	0.44	-	0.76	0.64	0.44	-		
ΔT	17	15	11	-	17	15	11	-	17	15	11	-	17	15	11	-	17	15	11	-	16	14	10	-		
kW	1.20	1.23	1.26	-	1.29	1.31	1.35	-	1.36	1.39	1.43	-	1.43	1.46	1.50	-	1.49	1.52	1.56	-	1.53	1.57	1.62	-		
Amps	4.5	4.6	4.7	-	4.8	5.0	5.1	-	5.3	5.4	5.6	-	5.6	5.7	5.9	-	6.0	6.1	6.3	-	6.3	6.5	6.7	-		
Hi PR	130	140	148	-	146	157	166	-	166	179	189	-	189	203	215	-	213	229	242	-	235	253	267	-		
Lo PR	60	64	70	-	64	68	74	-	66	70	77	-	70	74	81	-	73	78	85	-	75	80	88	-		

75	731	MBh	17.94	18.47	19.99	21.45	17.52	18.04	19.53	20.96	17.10	17.61	19.06	20.46	16.69	17.18	18.60	19.96	15.85	16.32	17.67	18.96	14.68	15.12	16.36	17.56
		S/T	0.82	0.74	0.56	0.36	0.85	0.76	0.58	0.37	0.87	0.78	0.59	0.38	0.90	0.81	0.61	0.39	0.94	0.84	0.63	0.41	0.94	0.84	0.64	0.41
	ΔT	19	17	14	10	19	17	14	10	19	17	14	10	19	17	14	10	19	17	14	10	17	16	13	9	
	kW	1.25	1.27	1.31	1.35	1.34	1.37	1.41	1.45	1.42	1.45	1.49	1.54	1.49	1.52	1.56	1.61	1.55	1.58	1.63	1.68	1.60	1.63	1.68	1.74	
	Amps	4.7	4.8	5.0	5.1	5.1	5.2	5.4	5.5	5.5	5.6	5.8	6.0	5.9	6.0	6.2	6.4	6.2	6.4	6.6	6.8	6.6	6.8	7.0	7.2	
	Hi PR	137	147	155	162	154	165	174	182	175	188	198	207	199	214	226	236	224	241	254	265	247	266	281	293	
	Lo PR	63	67	74	78	67	71	78	83	70	74	81	86	73	78	85	91	77	82	89	95	79	84	92	98	
	MBh	17.4	17.9	19.4	20.8	17.0	17.5	19.0	20.3	16.6	17.1	18.5	19.9	16.2	16.7	18.1	19.4	15.4	15.8	17.2	18.4	14.3	14.7	15.9	17.1	
	S/T	0.78	0.70	0.53	0.34	0.81	0.73	0.55	0.35	0.83	0.75	0.56	0.36	0.86	0.77	0.58	0.37	0.89	0.80	0.60	0.39	0.90	0.81	0.61	0.39	
	ΔT	19	18	15	10	20	18	15	10	20	18	15	10	20	18	15	10	19	18	15	10	18	17	14	9	
kW	1.24	1.26	1.30	1.34	1.33	1.35	1.40	1.44	1.41	1.44	1.48	1.53	1.48	1.51	1.55	1.60	1.53	1.57	1.62	1.67	1.58	1.62	1.67	1.72		
Amps	4.7	4.8	4.9	5.1	5.0	5.1	5.3	5.5	5.4	5.6	5.8	6.0	5.8	5.9	6.1	6.4	6.2	6.3	6.5	6.8	6.5	6.7	6.9	7.2		
Hi PR	135	146	154	161	152	164	173	180	173	186	196	205	197	212	224	233	222	238	252	263	245	263	278	290		
Lo PR	63	67	73	78	66	71	77	82	69	73	80	85	72	77	84	90	76	81	88	94	79	84	91	97		
MBh	16.1	16.5	17.9	19.2	15.7	16.2	17.5	18.8	15.3	15.8	17.1	18.3	15.0	15.40	16.7	17.9	14.2	14.6	15.8	17.0	13.2	13.5	14.7	15.7		
S/T	0.76	0.68	0.51	0.33	0.78	0.70	0.53	0.34	0.80	0.72	0.54	0.35	0.83	0.74	0.56	0.36	0.86	0.77	0.58	0.37	0.87	0.78	0.59	0.38		
ΔT	20	18	15	10	20	18	15	10	20	18	15	10	20	18	15	10	20	18	15	10	20	18	14	10		
kW	1.21	1.24	1.27	1.31	1.30	1.32	1.36	1.40	1.37	1.40	1.44	1.49	1.44	1.47	1.52	1.56	1.50	1.53	1.58	1.63	1.55	1.58	1.63	1.68		
Amps	4.5	4.6	4.8	5.0	4.9	5.0	5.2	5.4	5.3	5.4	5.6	5.8	5.7	5.8	6.0	6.2	6.0	6.2	6.4	6.6	6.4	6.5	6.7	7.0		
Hi PR	131	141	149	156	147	159	168	175	168	180	191	199	191	206	217	226	215	231	244	255	237	255	270	281		
Lo PR	61	65	71	75	64	68	75	80	67	71	78	83	70	75	82	87	74	78	86	91	76	81	88	94		

IDB: Entering Indoor Dry Bulb Temperature kW = Total system power Shaded area reflects ACCA (TVA) conditions Amps = outdoor unit amps (comp. +fan)
 High and low pressures are measured at the liquid and suction service valves. Design Subcooling 9 ±3 °F @ the liquid service valve, ARI 95 test conditions

EXPANDED COOLING DATA — GSH130181B* / AR*F182416** (CONT.)

IDB	Airflow	Outdoor Ambient Temperature																							
		65°F				75°F				85°F				95°F				105°F				115°F			
		59	63	67	71	59	63	67	71	59	63	67	71	59	63	67	71	59	63	67	71	59	63	67	71
80	MBh	18.26	18.65	19.93	21.31	17.83	18.22	19.47	20.81	17.41	17.79	19.00	20.31	16.98	17.35	18.54	19.82	16.13	16.49	17.61	18.83	14.94	15.27	16.32	17.44
	S/T	0.90	0.85	0.69	0.51	0.93	0.88	0.71	0.53	0.96	0.90	0.73	0.55	1.00	0.93	0.75	0.56	1.00	0.96	0.78	0.59	1.00	0.97	0.79	0.59
	ΔT	21	20	17	14	21	20	17	14	21	20	17	14	21	20	18	14	20	20	17	14	19	19	16	13
	kW	1.26	1.28	1.32	1.36	1.35	1.38	1.42	1.46	1.43	1.46	1.50	1.55	1.50	1.53	1.58	1.63	1.56	1.59	1.64	1.69	1.61	1.64	1.70	1.75
	Amps	4.7	4.9	5.0	5.2	5.1	5.2	5.4	5.6	5.5	5.7	5.9	6.1	5.9	6.1	6.3	6.5	6.4	6.7	6.9	7.2	6.7	6.8	7.0	7.3
	Hi PR	138	149	157	164	155	167	176	184	176	190	200	209	201	216	228	238	226	243	257	268	250	269	284	296
	Lo PR	64	68	74	79	68	72	79	84	70	75	82	87	74	79	86	91	77	82	90	96	80	85	93	99
	MBh	17.7	18.1	19.4	20.7	17.3	17.7	18.9	20.2	16.9	17.3	18.5	19.7	16.5	16.8	18.0	19.2	15.7	16.0	17.1	18.3	14.5	14.8	15.8	16.9
	S/T	0.86	0.81	0.66	0.49	0.89	0.84	0.68	0.51	0.91	0.86	0.70	0.52	0.94	0.88	0.72	0.54	0.98	0.92	0.75	0.56	0.99	0.93	0.75	0.56
	ΔT	22	21	18	14	22	21	18	15	22	21	18	15	22	21	18	15	22	21	18	14	20	19	17	13
kW	1.25	1.27	1.31	1.35	1.34	1.37	1.41	1.45	1.42	1.45	1.49	1.54	1.49	1.52	1.57	1.61	1.55	1.58	1.63	1.68	1.60	1.63	1.68	1.74	
Amps	4.7	4.8	5.0	5.1	5.1	5.2	5.4	5.5	5.5	5.6	5.8	6.0	5.9	6.0	6.2	6.4	6.2	6.4	6.6	6.8	6.6	6.8	7.0	7.2	
Hi PR	137	147	155	162	154	165	174	182	175	188	198	207	199	214	226	236	224	241	254	265	247	266	281	293	
Lo PR	63	68	74	78	67	71	78	83	70	74	81	86	73	78	85	91	77	82	89	95	79	84	92	98	
MBh	16.4	16.7	17.9	19.1	16.0	16.3	17.4	18.6	15.6	15.9	17.0	18.2	15.2	15.6	16.6	17.8	14.5	14.8	15.8	16.9	13.4	13.7	14.6	15.6	
S/T	0.83	0.78	0.63	0.47	0.86	0.81	0.66	0.49	0.88	0.83	0.67	0.50	0.91	0.85	0.69	0.52	0.94	0.89	0.72	0.54	0.95	0.89	0.73	0.54	
ΔT	22	21	18	15	22	21	18	15	22	21	19	15	22	21	19	15	22	21	18	15	21	20	17	14	
kW	1.22	1.24	1.28	1.32	1.31	1.33	1.37	1.42	1.38	1.41	1.46	1.50	1.45	1.48	1.53	1.58	1.51	1.54	1.59	1.64	1.56	1.59	1.64	1.69	
Amps	4.6	4.7	4.8	5.0	4.9	5.1	5.2	5.4	5.3	5.5	5.7	5.9	5.7	5.8	6.0	6.3	6.1	6.2	6.4	6.7	6.4	6.6	6.8	7.0	
Hi PR	133	143	151	157	149	160	169	177	169	182	192	201	193	208	219	229	217	234	247	257	240	258	272	284	
Lo PR	62	65	71	76	65	69	76	80	68	72	78	84	71	76	82	88	74	79	86	92	77	82	89	95	

85	MBh	18.58	18.93	19.83	21.16	18.14	18.49	19.37	20.66	17.71	18.05	18.91	20.17	17.28	17.61	18.45	19.68	16.42	16.73	17.52	18.70	15.21	15.50	16.23	17.32
	S/T	0.95	0.91	0.82	0.67	0.98	0.95	0.85	0.69	1.00	0.97	0.87	0.71	1.00	1.00	0.90	0.73	1.00	1.00	0.94	0.76	1.00	1.00	0.94	0.77
	ΔT	22	22	21	18	22	22	21	18	22	22	21	18	22	22	21	18	21	21	21	18	19	19	19	17
	kW	1.27	1.29	1.33	1.37	1.36	1.39	1.43	1.47	1.44	1.47	1.51	1.56	1.51	1.54	1.59	1.64	1.57	1.60	1.65	1.71	1.62	1.66	1.71	1.77
	Amps	4.8	4.9	5.1	5.2	5.2	5.3	5.4	5.6	5.6	5.7	5.9	6.1	6.0	6.1	6.3	6.5	6.3	6.5	6.7	7.0	6.7	6.9	7.1	7.4
	Hi PR	140	150	159	165	157	169	178	186	178	192	202	211	203	218	231	240	228	246	259	271	252	271	287	299
	Lo PR	65	69	75	80	68	73	79	85	71	76	83	88	75	79	87	92	78	83	91	97	81	86	94	100
	MBh	18.0	18.4	19.3	20.5	17.6	18.0	18.8	20.1	17.2	17.5	18.4	19.6	16.8	17.1	17.9	19.1	15.9	16.2	17.0	18.2	14.8	15.0	15.8	16.8
	S/T	0.90	0.87	0.79	0.64	0.93	0.90	0.81	0.66	0.96	0.92	0.83	0.68	0.99	0.95	0.86	0.70	1.00	0.99	0.89	0.73	1.00	1.00	0.90	0.73
	ΔT	23	23	21	19	23	23	22	19	23	23	22	19	23	23	22	19	23	23	22	19	21	21	20	17
kW	1.26	1.28	1.32	1.36	1.35	1.38	1.42	1.46	1.43	1.46	1.50	1.55	1.50	1.53	1.58	1.63	1.56	1.59	1.64	1.69	1.61	1.64	1.70	1.75	
Amps	4.7	4.9	5.0	5.2	5.1	5.2	5.4	5.6	5.5	5.7	5.9	6.1	5.9	6.1	6.3	6.5	6.3	6.4	6.7	6.9	6.7	6.8	7.0	7.3	
Hi PR	138	149	157	164	155	167	176	184	176	190	200	209	201	216	228	238	226	243	257	268	250	269	284	296	
Lo PR	64	68	74	79	68	72	79	84	70	75	82	87	74	79	86	91	77	82	90	96	80	85	93	99	
MBh	16.6	17.0	17.8	19.0	16.3	16.6	17.4	18.5	15.9	16.2	16.9	18.1	15.5	15.8	16.5	17.6	14.7	15.0	15.7	16.8	13.6	13.9	14.5	15.5	
S/T	0.87	0.84	0.76	0.61	0.90	0.87	0.78	0.64	0.92	0.89	0.80	0.65	0.95	0.92	0.83	0.67	0.99	0.95	0.86	0.70	1.00	0.96	0.87	0.71	
ΔT	23	23	22	19	24	23	22	19	24	23	22	19	24	23	22	19	24	23	22	19	22	22	20	18	
kW	1.23	1.25	1.29	1.33	1.32	1.34	1.38	1.43	1.39	1.42	1.47	1.51	1.46	1.49	1.54	1.59	1.52	1.55	1.60	1.65	1.57	1.60	1.66	1.71	
Amps	4.6	4.7	4.9	5.0	5.0	5.1	5.3	5.4	5.4	5.5	5.7	5.9	5.8	5.9	6.1	6.3	6.1	6.3	6.5	6.7	6.5	6.6	6.8	7.1	
Hi PR	134	144	152	159	150	162	171	178	171	184	194	203	195	210	221	231	219	236	249	260	242	261	275	287	
Lo PR	62	66	72	77	66	70	76	81	68	73	79	84	72	76	83	89	75	80	87	93	78	83	90	96	

IDB: Entering Indoor Dry Bulb Temperature kW = Total system power Shaded area reflects ARI Rating conditions Amps = outdoor unit amps (comp. +fan)
 High and low pressures are measured at the liquid and suction service valves. Design Subcooling ± 3 °F @ the liquid service valve, ARI 95 test conditions

EXPANDED COOLING DATA — GSH130191A* / AWUF18XX1A*

IDB	Airflow	Outdoor Ambient Temperature																								
		65°F				75°F				85°F				95°F				105°F				115°F				
		59	63	67	71	59	63	67	71	59	63	67	71	59	63	67	71	59	63	67	71	59	63	67	71	
70	675	MBh	17.6	18.3	20.0	-	17.2	17.9	19.6	-	16.8	17.4	19.1	-	16.4	17.0	18.6	-	15.6	16.2	17.7	-	14.4	15.0	16.4	-
		S/T	0.75	0.63	0.44	-	0.78	0.65	0.45	-	0.80	0.67	0.46	-	0.82	0.69	0.48	-	0.86	0.71	0.50	-	0.86	0.72	0.50	-
	ΔT	18	16	12	-	18	16	12	-	18	16	12	-	18	16	12	-	18	16	12	-	17	15	11	-	
	kW	1.25	1.27	1.31	-	1.33	1.36	1.40	-	1.41	1.44	1.48	-	1.47	1.50	1.55	-	1.53	1.56	1.61	-	1.58	1.61	1.66	-	
	Amps	4.0	4.1	4.2	-	4.3	4.4	4.5	-	4.6	4.7	4.9	-	4.9	5.0	5.2	-	5.2	5.3	5.4	-	5.4	5.6	5.7	-	
	Hi PR	136	146	155	-	153	164	173	-	174	187	197	-	198	213	225	-	222	239	253	-	246	264	279	-	
	Lo PR	61	65	71	-	65	69	75	-	67	71	78	-	70	75	82	-	74	79	86	-	76	81	89	-	
	MBh	17.1	17.7	19.4	-	16.7	17.3	19.0	-	16.3	16.9	18.5	-	15.9	16.5	18.1	-	15.1	15.7	17.2	-	14.0	14.5	15.9	-	
	S/T	0.72	0.60	0.41	-	0.74	0.62	0.43	-	0.76	0.64	0.44	-	0.79	0.66	0.46	-	0.82	0.68	0.47	-	0.82	0.69	0.48	-	
	ΔT	19	16	12	-	19	16	13	-	19	17	13	-	19	17	13	-	19	16	12	-	18	15	12	-	
kW	1.24	1.26	1.30	-	1.32	1.35	1.39	-	1.40	1.43	1.47	-	1.46	1.49	1.54	-	1.52	1.55	1.60	-	1.57	1.60	1.65	-		
Amps	4.0	4.1	4.2	-	4.3	4.4	4.5	-	4.6	4.7	4.8	-	4.9	5.0	5.1	-	5.1	5.2	5.4	-	5.4	5.5	5.7	-		
Hi PR	135	145	153	-	151	163	172	-	172	185	195	-	196	211	222	-	220	237	250	-	243	262	277	-		
Lo PR	61	64	70	-	64	68	74	-	66	71	77	-	70	74	81	-	73	78	85	-	76	80	88	-		
MBh	15.8	16.4	17.9	-	15.4	16.0	17.5	-	15.1	15.6	17.1	-	14.7	15.2	16.7	-	14.0	14.5	15.9	-	12.9	13.4	14.7	-		
S/T	0.69	0.58	0.40	-	0.72	0.60	0.41	-	0.73	0.61	0.43	-	0.76	0.63	0.44	-	0.79	0.66	0.46	-	0.79	0.66	0.46	-		
ΔT	19	17	13	-	19	17	13	-	19	17	13	-	20	17	13	-	19	17	13	-	18	16	12	-		
kW	1.22	1.24	1.27	-	1.30	1.32	1.36	-	1.37	1.39	1.43	-	1.43	1.46	1.50	-	1.48	1.51	1.56	-	1.53	1.56	1.61	-		
Amps	3.9	4.0	4.1	-	4.2	4.3	4.4	-	4.5	4.6	4.7	-	4.7	4.8	5.0	-	5.0	5.1	5.3	-	5.3	5.4	5.5	-		
Hi PR	131	141	148	-	147	158	167	-	167	179	189	-	190	204	216	-	214	230	243	-	236	254	268	-		
Lo PR	59	62	68	-	62	66	72	-	64	69	75	-	68	72	79	-	71	75	82	-	73	78	85	-		

75	675	MBh	17.94	18.47	19.99	21.45	17.52	18.04	19.53	20.96	17.10	17.61	19.06	20.46	16.69	17.18	18.60	19.96	15.85	16.32	17.67	18.96	14.68	15.12	16.36	17.56
		S/T	0.85	0.76	0.58	0.37	0.89	0.79	0.60	0.39	0.91	0.81	0.61	0.40	0.94	0.84	0.63	0.41	0.97	0.87	0.66	0.42	0.98	0.88	0.66	0.43
	ΔT	21	19	16	11	21	19	16	11	21	19	16	11	21	20	16	11	21	19	16	11	20	18	15	10	
	kW	1.26	1.28	1.32	1.36	1.34	1.37	1.41	1.45	1.42	1.45	1.49	1.53	1.49	1.52	1.56	1.61	1.54	1.57	1.62	1.67	1.59	1.62	1.67	1.72	
	Amps	4.1	4.1	4.3	4.4	4.3	4.4	4.6	4.7	4.7	4.8	4.9	5.1	4.9	5.0	5.2	5.4	5.2	5.3	5.5	5.7	5.5	5.6	5.8	6.0	
	Hi PR	137	148	156	163	154	166	175	183	175	189	199	208	200	215	227	237	225	242	255	266	248	267	282	294	
	Lo PR	62	66	72	76	65	69	76	81	68	72	79	84	71	76	83	88	75	79	87	92	77	82	90	95	
	MBh	17.4	17.9	19.4	20.8	17.0	17.5	19.0	20.3	16.6	17.1	18.5	19.9	16.2	16.7	18.1	19.4	15.4	15.8	17.2	18.4	14.3	14.7	15.9	17.1	
	S/T	0.82	0.73	0.55	0.35	0.84	0.76	0.57	0.37	0.87	0.77	0.59	0.38	0.89	0.80	0.61	0.39	0.93	0.83	0.63	0.40	0.94	0.84	0.63	0.41	
	ΔT	22	20	16	11	22	20	17	11	22	20	17	11	22	20	17	12	22	20	17	11	20	19	15	11	
kW	1.25	1.27	1.31	1.35	1.33	1.36	1.40	1.44	1.41	1.44	1.48	1.52	1.47	1.50	1.55	1.60	1.53	1.56	1.61	1.66	1.58	1.61	1.66	1.71		
Amps	4.0	4.1	4.2	4.4	4.3	4.4	4.5	4.7	4.6	4.7	4.9	5.0	4.9	5.0	5.2	5.3	5.2	5.3	5.4	5.6	5.5	5.6	5.7	5.9		
Hi PR	136	146	155	161	153	164	173	181	174	187	197	206	198	213	225	234	222	239	253	264	246	265	279	291		
Lo PR	61	65	71	76	65	69	75	80	67	71	78	83	71	75	82	87	74	79	86	91	76	81	89	95		
MBh	16.1	16.5	17.9	19.2	15.7	16.2	17.5	18.8	15.3	15.8	17.1	18.3	15.0	15.40	16.7	17.9	14.2	14.6	15.8	17.0	13.2	13.5	14.7	15.7		
S/T	0.79	0.70	0.53	0.34	0.81	0.73	0.55	0.35	0.84	0.75	0.57	0.36	0.86	0.77	0.58	0.38	0.89	0.80	0.61	0.39	0.90	0.81	0.61	0.39		
ΔT	22	20	17	12	22	21	17	12	22	21	17	12	23	21	17	12	22	20	17	12	21	19	16	11		
kW	1.22	1.25	1.28	1.32	1.31	1.33	1.37	1.41	1.38	1.40	1.45	1.49	1.44	1.47	1.51	1.56	1.50	1.53	1.57	1.62	1.54	1.57	1.62	1.67		
Amps	3.9	4.0	4.1	4.3	4.2	4.3	4.4	4.5	4.5	4.6	4.7	4.9	4.8	4.9	5.0	5.2	5.0	5.2	5.3	5.5	5.3	5.4	5.6	5.8		
Hi PR	132	142	150	156	148	159	168	176	168	181	191	200	192	206	218	227	216	232	245	256	238	257	271	283		
Lo PR	59	63	69	73	63	67	73	77	65	69	76	81	68	73	79	85	72	76	83	89	74	79	86	92		

IDB: Entering Indoor Dry Bulb Temperature kW = Total system power Shaded area reflects ACCA (TVA) conditions Amps = outdoor unit amps (comp.+fan)
 High and low pressures are measured at the liquid and suction service valves. Design Subcooling 9 ±3 °F @ the liquid service valve, ARI 95 test conditions

EXPANDED COOLING DATA — GSH130191A* / AWUF18XX1A* (CONT.)

IDB	Airflow	Outdoor Ambient Temperature																								
		65°F				75°F				85°F				95°F				105°F				115°F				
		59	63	67	71	59	63	67	71	59	63	67	71	59	63	67	71	59	63	67	71	59	63	67	71	
80	675	MBh	18.3	18.7	19.9	21.3	17.8	18.2	19.5	20.8	17.4	17.8	19.0	20.3	17.0	17.4	18.5	19.8	16.1	16.5	17.6	18.8	14.9	15.3	16.3	17.4
		S/T	0.94	0.88	0.72	0.53	1.00	0.91	0.74	0.55	1.00	0.93	0.76	0.57	1.00	0.96	0.78	0.59	1.00	1.00	0.81	0.61	1.00	1.00	0.82	0.61
	ΔT	23	22	19	16	24	23	20	16	24	23	20	16	23	23	20	16	22	22	20	16	20	21	18	15	
	kW	1.27	1.29	1.33	1.37	1.35	1.38	1.42	1.46	1.43	1.46	1.50	1.55	1.50	1.53	1.57	1.62	1.55	1.59	1.63	1.68	1.60	1.64	1.69	1.74	
	Amps	4.1	4.2	4.3	4.4	4.4	4.5	4.6	4.7	4.7	4.8	4.9	5.1	5.0	5.1	5.2	5.4	5.3	5.4	5.5	5.7	5.5	5.7	5.8	6.0	
	Hi-PR	139	149	158	165	156	168	177	185	177	191	201	210	202	217	229	239	227	244	258	269	251	270	285	297	
	Lo-PR	62	66	72	77	66	70	77	81	68	73	80	85	72	77	84	89	75	80	88	93	78	83	91	96	
	MBh	17.7	18.1	19.4	20.7	17.3	17.7	18.9	20.2	16.9	17.3	18.5	19.7	16.5	16.8	18.0	19.2	15.7	16.0	17.1	18.3	14.5	14.8	15.8	16.9	
	S/T	0.89	0.84	0.68	0.51	0.93	0.87	0.71	0.53	0.95	0.89	0.73	0.54	0.98	0.92	0.75	0.56	1.00	0.95	0.78	0.58	1.00	0.96	0.78	0.59	
	ΔT	24	23	20	16	25	24	20	16	25	24	21	16	25	24	21	16	24	23	20	16	22	22	19	15	
kW	1.26	1.28	1.32	1.36	1.34	1.37	1.41	1.45	1.42	1.45	1.49	1.53	1.49	1.52	1.56	1.61	1.54	1.57	1.62	1.67	1.59	1.62	1.67	1.72		
Amps	4.1	4.1	4.3	4.4	4.3	4.4	4.6	4.7	4.7	4.8	4.9	5.1	4.9	5.0	5.2	5.4	5.2	5.3	5.5	5.7	5.5	5.6	5.8	6.0		
Hi-PR	137	148	156	163	154	166	175	183	175	189	199	208	200	215	227	237	225	242	255	266	248	267	282	294		
Lo-PR	62	66	72	76	65	69	76	81	68	72	79	84	71	76	83	88	75	79	87	92	77	82	90	95		
MBh	16.4	16.7	17.9	19.1	16.0	16.3	17.4	18.6	15.6	15.9	17.0	18.2	15.2	15.6	16.6	17.8	14.5	14.8	15.8	16.9	13.4	13.7	14.6	15.6		
S/T	0.86	0.81	0.66	0.49	0.89	0.84	0.68	0.51	0.92	0.86	0.70	0.52	0.95	0.89	0.72	0.54	0.98	0.92	0.75	0.56	0.99	0.93	0.76	0.56		
ΔT	25	24	21	16	25	24	21	17	25	24	21	17	25	24	21	17	25	24	21	17	23	22	19	15		
kW	1.23	1.25	1.29	1.33	1.31	1.34	1.38	1.42	1.39	1.41	1.46	1.50	1.45	1.48	1.52	1.57	1.51	1.54	1.58	1.63	1.55	1.59	1.63	1.68		
Amps	4.0	4.0	4.2	4.3	4.2	4.3	4.4	4.6	4.5	4.6	4.8	4.9	4.8	4.9	5.1	5.2	5.1	5.2	5.4	5.5	5.4	5.5	5.6	5.8		
Hi-PR	133	143	151	158	150	161	170	177	170	183	193	202	194	209	220	230	218	235	248	258	241	259	274	285		
Lo-PR	60	64	70	74	63	67	73	78	66	70	76	81	69	73	80	85	72	77	84	90	75	80	87	93		

85	675	MBh	18.6	18.9	19.8	21.2	18.1	18.5	19.4	20.7	17.7	18.1	18.9	20.2	17.3	17.6	18.4	19.7	16.4	16.7	17.5	18.7	15.2	15.5	16.2	17.3
		S/T	0.98	0.95	0.86	0.69	1.00	0.98	0.89	0.72	1.00	1.00	0.91	0.74	1.00	1.00	0.94	0.76	1.00	1.00	0.97	0.79	1.00	1.00	0.98	0.80
	ΔT	25	24	23	20	25	25	23	20	24	25	23	20	24	24	24	20	22	23	23	20	21	21	22	19	
	kW	1.28	1.30	1.34	1.38	1.36	1.39	1.43	1.47	1.44	1.47	1.51	1.56	1.51	1.54	1.58	1.63	1.57	1.60	1.65	1.70	1.62	1.65	1.70	1.75	
	Amps	4.1	4.2	4.3	4.5	4.4	4.5	4.6	4.8	4.7	4.8	5.0	5.1	5.0	5.1	5.3	5.5	5.3	5.4	5.6	5.8	5.6	5.7	5.9	6.1	
	Hi-PR	140	151	159	166	157	169	179	186	179	193	203	212	204	219	232	242	229	247	260	272	253	273	288	300	
	Lo-PR	63	67	73	78	67	71	77	82	69	74	80	86	73	77	84	90	76	81	88	94	79	84	91	97	
	MBh	18.0	18.4	19.3	20.5	17.6	18.0	18.8	20.1	17.2	17.5	18.4	19.6	16.8	17.1	17.9	19.1	15.9	16.2	17.0	18.2	14.8	15.0	15.8	16.8	
	S/T	0.94	0.90	0.82	0.66	0.97	0.94	0.85	0.69	1.00	0.96	0.87	0.70	1.00	0.99	0.90	0.73	1.00	1.00	0.93	0.75	1.00	1.00	0.94	0.76	
	ΔT	26	25	24	21	26	26	24	21	26	26	24	21	26	26	25	21	24	25	24	21	23	23	23	20	
kW	1.27	1.29	1.33	1.37	1.35	1.38	1.42	1.46	1.43	1.46	1.50	1.55	1.50	1.53	1.57	1.62	1.55	1.59	1.63	1.68	1.60	1.64	1.69	1.74		
Amps	4.1	4.2	4.3	4.4	4.4	4.5	4.6	4.7	4.7	4.8	4.9	5.1	5.0	5.1	5.2	5.4	5.3	5.4	5.5	5.7	5.5	5.7	5.8	6.0		
Hi-PR	139	149	158	165	156	168	177	185	177	191	201	210	202	217	229	239	227	244	258	269	251	270	285	297		
Lo-PR	62	66	72	77	66	70	77	81	68	73	80	85	72	77	84	89	75	80	88	93	78	83	91	96		
MBh	16.6	17.0	17.8	19.0	16.3	16.6	17.4	18.5	15.9	16.2	16.9	18.1	15.5	15.8	16.5	17.6	14.7	15.0	15.7	16.8	13.6	13.9	14.5	15.5		
S/T	0.90	0.87	0.79	0.64	0.94	0.90	0.82	0.66	0.96	0.93	0.84	0.68	0.99	0.96	0.86	0.70	1.00	0.99	0.90	0.73	1.00	1.00	0.90	0.73		
ΔT	26	26	24	21	27	26	25	21	27	26	25	21	27	26	25	22	26	26	25	21	24	24	23	20		
kW	1.24	1.26	1.30	1.34	1.32	1.35	1.39	1.43	1.40	1.43	1.47	1.51	1.46	1.49	1.54	1.58	1.52	1.55	1.60	1.64	1.57	1.60	1.65	1.70		
Amps	4.0	4.1	4.2	4.3	4.3	4.4	4.5	4.6	4.6	4.7	4.8	5.0	4.9	5.0	5.1	5.3	5.1	5.2	5.4	5.6	5.4	5.5	5.7	5.9		
Hi-PR	135	145	153	160	151	163	172	179	172	185	195	204	196	211	222	232	220	237	250	261	243	262	276	288		
Lo-PR	60	64	70	75	64	68	74	79	66	71	77	82	70	74	81	86	73	78	85	90	76	80	88	94		

IDB: Entering Indoor Dry Bulb Temperature kW = Total system power Shaded area reflects ARI Rating conditions Amps = outdoor unit amps (comp.+fan)
 High and low pressures are measured at the liquid and suction service valves. Design Subcooling 9 ±3 °F @ the liquid service valve, ARI 95 test conditions

EXPANDED COOLING DATA — GSH130241A* / ARUF32-00*-1* / ARUF18241A*

IDB	Airflow	Outdoor Ambient Temperature																								
		65°F				75°F				85°F				95°F				105°F				115°F				
		59	63	67	71	59	63	67	71	59	63	67	71	59	63	67	71	59	63	67	71	59	63	67	71	
70	923	MBh	22.5	23.4	25.6	-	22.0	22.8	25.0	-	21.5	22.3	24.4	-	21.0	21.7	23.8	-	19.9	20.6	22.6	-	18.4	19.1	21.0	-
		S/T	0.74	0.62	0.43	-	0.77	0.64	0.45	-	0.79	0.66	0.46	-	0.81	0.68	0.47	-	0.85	0.71	0.49	-	0.85	0.71	0.49	-
		ΔT	17	14	11	-	17	15	11	-	17	15	11	-	17	15	11	-	17	15	11	-	16	14	10	-
		kW	1.64	1.67	1.72	-	1.76	1.79	1.85	-	1.86	1.90	1.96	-	1.96	2.00	2.06	-	2.04	2.08	2.15	-	2.10	2.15	2.22	-
		Amps	6.1	6.3	6.5	-	6.6	6.8	7.0	-	7.2	7.4	7.6	-	7.7	7.9	8.1	-	8.2	8.4	8.6	-	8.6	8.8	9.1	-
	820	Hi PR	137	148	156	-	154	166	175	-	175	189	199	-	200	215	227	-	224	242	255	-	248	267	282	-
		Lo PR	61	65	71	-	64	69	75	-	67	71	78	-	70	75	82	-	74	78	86	-	76	81	89	-
		MBh	21.9	22.7	24.8	-	21.4	22.2	24.3	-	20.9	21.6	23.7	-	20.4	21.1	23.1	-	19.3	20.0	22.0	-	17.9	18.6	20.3	-
		S/T	0.71	0.59	0.41	-	0.73	0.61	0.42	-	0.75	0.63	0.44	-	0.78	0.65	0.45	-	0.81	0.67	0.47	-	0.81	0.68	0.47	-
		ΔT	17	15	11	-	18	15	12	-	18	15	12	-	18	15	12	-	17	15	11	-	16	14	11	-
718	kW	1.62	1.66	1.71	-	1.74	1.78	1.83	-	1.85	1.89	1.95	-	1.94	1.98	2.04	-	2.02	2.06	2.13	-	2.09	2.13	2.20	-	
	Amps	6.1	6.2	6.4	-	6.6	6.7	6.9	-	7.1	7.3	7.5	-	7.6	7.8	8.0	-	8.1	8.3	8.6	-	8.6	8.8	9.1	-	
	Hi PR	136	146	154	-	153	164	173	-	173	187	197	-	198	213	224	-	222	239	253	-	246	264	279	-	
	Lo PR	60	64	70	-	64	68	74	-	66	71	77	-	70	74	81	-	73	78	85	-	75	80	88	-	
	MBh	20.2	20.9	22.9	-	19.7	20.4	22.4	-	19.3	20.0	21.9	-	18.8	19.5	21.3	-	17.8	18.5	20.3	-	16.5	17.1	18.8	-	

IDB	Airflow	Outdoor Ambient Temperature																								
		65°F				75°F				85°F				95°F				105°F				115°F				
		59	63	67	71	59	63	67	71	59	63	67	71	59	63	67	71	59	63	67	71	59	63	67	71	
75	923	MBh	22.92	23.60	25.54	27.41	22.39	23.05	24.95	26.78	21.85	22.50	24.36	26.14	21.32	21.95	23.76	25.50	20.25	20.85	22.57	24.23	18.76	19.32	20.91	22.44
		S/T	0.84	0.75	0.57	0.37	0.87	0.78	0.59	0.38	0.90	0.80	0.61	0.39	0.93	0.83	0.63	0.40	0.96	0.86	0.65	0.42	0.97	0.87	0.66	0.42
		ΔT	19	18	15	10	20	18	15	10	20	18	15	10	20	18	15	10	19	18	15	10	18	17	14	9
		kW	1.65	1.68	1.73	1.79	1.77	1.81	1.86	1.92	1.88	1.92	1.98	2.04	1.97	2.01	2.08	2.15	2.05	2.10	2.16	2.24	2.12	2.17	2.24	2.31
		Amps	6.2	6.3	6.5	6.8	6.7	6.8	7.1	7.3	7.2	7.4	7.7	7.9	7.7	7.9	8.2	8.5	8.2	8.4	8.7	9.0	8.7	8.9	9.2	9.6
	820	Hi PR	139	149	158	164	156	167	177	184	177	190	201	210	202	217	229	239	227	244	258	269	251	270	285	297
		Lo PR	62	66	72	76	65	69	76	81	68	72	79	84	71	76	83	88	74	79	86	92	77	82	89	95
		MBh	22.3	22.9	24.8	26.6	21.7	22.4	24.2	26.0	21.2	21.8	23.6	25.4	20.7	21.3	23.1	24.8	19.7	20.2	21.9	23.5	18.2	18.8	20.3	21.8
		S/T	0.80	0.72	0.54	0.35	0.83	0.75	0.56	0.36	0.86	0.77	0.58	0.37	0.88	0.79	0.60	0.38	0.92	0.82	0.62	0.40	0.92	0.83	0.63	0.40
		ΔT	20	18	15	10	20	19	15	11	20	19	15	11	20	19	15	11	20	19	15	11	19	17	14	10
718	kW	1.64	1.67	1.72	1.77	1.76	1.79	1.85	1.91	1.86	1.90	1.96	2.02	1.96	2.00	2.06	2.13	2.04	2.08	2.15	2.22	2.10	2.15	2.22	2.29	
	Amps	6.1	6.3	6.5	6.7	6.6	6.8	7.0	7.3	7.2	7.4	7.6	7.9	7.7	7.9	8.1	8.4	8.2	8.4	8.6	9.0	8.6	8.8	9.1	9.5	
	Hi PR	137	148	156	163	154	166	175	183	175	189	199	208	200	215	227	237	225	242	255	266	248	267	282	294	
	Lo PR	61	65	71	75	64	69	75	80	67	71	78	83	70	75	82	87	74	78	86	91	76	81	89	94	
	MBh	20.5	21.1	22.9	24.6	20.1	20.7	22.4	24.0	19.6	20.2	21.8	23.4	19.1	19.67	21.3	22.9	18.2	18.7	20.2	21.7	16.8	17.3	18.7	20.1	

IDB: Entering Indoor Dry Bulb Temperature kW = Total system power Shaded area reflects ACCA (TVA) conditions Amps = outdoor unit amps (comp.+fan)
 High and low pressures are measured at the liquid and suction service valves. Design Subcooling 9 ±3 °F @ the liquid service valve, ARI 95 test conditions

EXPANDED COOLING DATA — GSH130241A* / ARUF32-00*-1* / ARUF18241A* (CONT.)

IDB	Airflow	Outdoor Ambient Temperature																							
		65°F				75°F				85°F				95°F				105°F				115°F			
		59	63	67	71	59	63	67	71	59	63	67	71	59	63	67	71	59	63	67	71	59	63	67	71
80	MBh	23.33	23.84	25.47	27.22	22.79	23.28	24.87	26.59	22.24	22.73	24.28	25.96	21.70	22.17	23.69	25.32	20.62	21.07	22.51	24.06	19.10	19.51	20.85	22.29
	S/T	0.93	0.87	0.71	0.53	0.96	0.90	0.73	0.55	1.00	0.92	0.75	0.56	1.00	0.95	0.78	0.58	1.00	1.00	0.80	0.60	1.00	1.00	0.81	0.61
	ΔT	22	21	18	14	22	21	18	15	22	21	18	15	22	21	18	15	21	21	18	14	19	19	17	13
	kW	1.66	1.69	1.75	1.80	1.78	1.82	1.88	1.94	1.89	1.93	1.99	2.06	1.99	2.03	2.10	2.16	2.07	2.11	2.18	2.25	2.14	2.19	2.26	2.33
	Amps	6.2	6.4	6.6	6.8	6.7	6.9	7.1	7.4	7.3	7.5	7.7	8.0	7.8	8.0	8.3	8.6	8.3	8.5	8.8	9.1	8.8	9.0	9.3	9.7
	Hi-PR	140	151	159	166	157	169	179	186	179	192	203	212	204	219	231	241	229	246	260	271	253	272	288	300
	Lo-PR	62	66	72	77	66	70	76	81	68	73	79	85	72	76	83	89	75	80	87	93	78	83	90	96
	MBh	22.6	23.1	24.7	26.4	22.1	22.6	24.2	25.8	21.6	22.1	23.6	25.2	21.1	21.5	23.0	24.6	20.0	20.5	21.9	23.4	18.5	18.9	20.2	21.6
	S/T	0.88	0.83	0.67	0.50	0.91	0.86	0.70	0.52	0.94	0.88	0.72	0.54	0.97	0.91	0.74	0.55	1.00	0.94	0.77	0.57	1.00	0.95	0.77	0.58
	ΔT	22	21	19	15	23	22	19	15	23	22	19	15	23	22	19	15	22	22	19	15	21	20	18	14
kW	1.65	1.68	1.73	1.79	1.77	1.81	1.86	1.92	1.88	1.92	1.98	2.04	1.97	2.01	2.08	2.15	2.05	2.10	2.16	2.24	2.12	2.17	2.24	2.31	
Amps	6.2	6.3	6.5	6.8	6.7	6.8	7.1	7.3	7.2	7.4	7.7	7.9	7.7	7.9	8.2	8.5	8.2	8.4	8.7	9.0	8.7	8.9	9.2	9.6	
Hi-PR	139	149	158	164	156	167	177	184	177	190	201	210	202	217	229	239	227	244	258	269	251	270	285	297	
Lo-PR	62	66	72	76	65	69	76	81	68	72	79	84	71	76	83	88	74	79	86	92	77	82	89	95	
MBh	20.9	21.4	22.8	24.4	20.4	20.9	22.3	23.8	19.9	20.4	21.8	23.3	19.4	19.9	21.2	22.7	18.5	18.9	20.2	21.6	17.1	17.5	18.7	20.0	
S/T	0.85	0.80	0.65	0.49	0.88	0.83	0.67	0.50	0.90	0.85	0.69	0.52	0.93	0.88	0.71	0.53	0.97	0.91	0.74	0.55	0.98	0.92	0.75	0.56	
ΔT	23	22	19	15	23	22	19	15	23	22	19	15	23	22	19	15	23	22	19	15	21	21	18	14	
kW	1.61	1.64	1.69	1.74	1.73	1.76	1.82	1.88	1.83	1.87	1.93	1.99	1.92	1.97	2.03	2.09	2.00	2.05	2.11	2.18	2.07	2.12	2.18	2.25	
Amps	6.0	6.2	6.4	6.6	6.5	6.7	6.9	7.1	7.0	7.2	7.5	7.7	7.5	7.7	8.0	8.3	8.0	8.2	8.5	8.8	8.5	8.7	9.0	9.3	
Hi-PR	135	145	153	159	151	162	172	179	172	185	195	203	196	210	222	232	220	237	250	261	243	262	276	288	
Lo-PR	60	64	69	74	63	67	73	78	66	70	76	81	69	73	80	85	72	77	84	89	75	79	87	92	

923	MBh	23.74	24.19	25.34	27.03	23.18	23.63	24.75	26.40	22.63	23.07	24.16	25.78	22.08	22.51	23.57	25.15	20.98	21.38	22.39	23.89	19.43	19.81	20.74	22.13
	S/T	0.97	0.94	0.84	0.69	1.00	0.97	0.88	0.71	1.00	0.99	0.90	0.73	1.00	1.00	0.93	0.75	1.00	1.00	0.96	0.78	1.00	1.00	0.97	0.79
	ΔT	23	23	21	18	23	23	22	19	23	23	22	19	22	22	22	19	21	21	21	19	19	20	20	17
	kW	1.67	1.71	1.76	1.81	1.80	1.84	1.89	1.95	1.91	1.95	2.01	2.07	2.00	2.05	2.11	2.18	2.09	2.13	2.20	2.27	2.16	2.20	2.28	2.35
	Amps	6.3	6.4	6.6	6.9	6.8	7.0	7.2	7.5	7.4	7.6	7.8	8.1	7.9	8.1	8.3	8.7	8.4	8.6	8.9	9.2	8.9	9.1	9.4	9.8
	Hi-PR	141	152	161	168	159	171	180	188	181	194	205	214	206	221	234	244	231	249	263	274	256	275	290	303
	Lo-PR	63	67	73	78	66	71	77	82	69	73	80	85	72	77	84	90	76	81	88	94	79	84	91	97
	MBh	23.0	23.5	24.6	26.2	22.5	22.9	24.0	25.6	22.0	22.4	23.5	25.0	21.4	21.9	22.9	24.4	20.4	20.8	21.7	23.2	18.9	19.2	20.1	21.5
	S/T	0.93	0.89	0.81	0.65	0.96	0.93	0.84	0.68	0.98	0.95	0.86	0.69	1.00	0.98	0.88	0.72	1.00	1.00	0.92	0.74	1.00	1.00	0.93	0.75
	ΔT	24	24	22	19	24	24	22	19	24	24	23	19	24	24	23	20	23	23	22	19	21	22	21	18
kW	1.66	1.69	1.75	1.80	1.78	1.82	1.88	1.94	1.89	1.93	1.99	2.06	1.99	2.03	2.10	2.16	2.07	2.11	2.18	2.25	2.14	2.19	2.26	2.33	
Amps	6.2	6.4	6.6	6.8	6.7	6.9	7.1	7.4	7.3	7.5	7.7	8.0	7.8	8.0	8.3	8.6	8.3	8.5	8.8	9.1	8.8	9.0	9.3	9.7	
Hi-PR	140	151	159	166	157	169	179	186	179	192	203	212	204	219	231	241	229	246	260	271	253	272	288	300	
Lo-PR	62	66	72	77	66	70	76	81	68	73	79	85	72	76	83	89	75	80	87	93	78	83	90	96	
MBh	21.3	21.7	22.7	24.2	20.8	21.2	22.2	23.7	20.3	20.7	21.7	23.1	19.8	20.2	21.1	22.5	18.8	19.2	20.1	21.4	17.4	17.7	18.6	19.8	
S/T	0.89	0.86	0.78	0.63	0.92	0.89	0.81	0.65	0.95	0.91	0.83	0.67	0.98	0.94	0.85	0.69	1.00	0.98	0.88	0.72	1.00	0.99	0.89	0.72	
ΔT	24	24	23	20	25	24	23	20	25	24	23	20	25	24	23	20	24	24	23	20	22	22	21	18	
kW	1.62	1.66	1.71	1.76	1.74	1.78	1.83	1.89	1.85	1.89	1.95	2.01	1.94	1.98	2.04	2.11	2.02	2.06	2.13	2.20	2.09	2.13	2.20	2.27	
Amps	6.1	6.2	6.4	6.6	6.6	6.7	6.9	7.2	7.1	7.3	7.5	7.8	7.6	7.8	8.0	8.3	8.1	8.3	8.6	8.9	8.6	8.8	9.1	9.4	
Hi-PR	136	146	154	161	152	164	173	181	173	187	197	206	197	213	224	234	222	239	252	263	245	264	279	291	
Lo-PR	60	64	70	75	64	68	74	79	66	71	77	82	70	74	81	86	73	78	85	90	75	80	88	93	

IDB: Entering Indoor Dry Bulb Temperature kW = Total system power Shaded area reflects ARI Rating conditions Amps = outdoor unit amps (comp.+fan)
 High and low pressures are measured at the liquid and suction service valves. Design Subcooling 9 ±3 °F @ the liquid service valve, ARI 95 test conditions

EXPANDED COOLING DATA — GSH130241B* / AR*F182416**

IDB	Airflow	Outdoor Ambient Temperature																								
		65°F				75°F				85°F				95°F				105°F				115°F				
		59	63	67	71	59	63	67	71	59	63	67	71	59	63	67	71	59	63	67	71	59	63	67	71	
70	956	MBh	22.5	23.4	25.6	-	22.0	22.8	25.0	-	21.5	22.3	24.4	-	21.0	21.7	23.8	-	19.9	20.6	22.6	-	18.4	19.1	21.0	-
		S/T	0.74	0.62	0.43	-	0.77	0.64	0.45	-	0.79	0.66	0.46	-	0.81	0.68	0.47	-	0.85	0.71	0.49	-	0.85	0.71	0.49	-
		ΔT	16	14	11	-	16	14	11	-	16	14	11	-	16	14	11	-	16	14	11	-	15	13	10	-
		kW	1.59	1.63	1.68	-	1.71	1.75	1.80	-	1.81	1.85	1.91	-	1.91	1.95	2.01	-	1.98	2.03	2.09	-	2.05	2.09	2.16	-
		Amps	5.8	6.0	6.2	-	6.3	6.4	6.7	-	6.8	7.0	7.2	-	7.3	7.5	7.7	-	7.8	8.0	8.2	-	8.2	8.4	8.7	-
	850	Hi-PR	140	151	159	-	157	169	179	-	179	193	203	-	204	219	232	-	229	247	261	-	253	273	288	-
		Lo-PR	62	66	72	-	65	69	76	-	68	72	79	-	71	76	83	-	75	79	87	-	77	82	90	-
		MBh	21.9	22.7	24.8	-	21.4	22.2	24.3	-	20.9	21.6	23.7	-	20.4	21.1	23.1	-	19.3	20.0	22.0	-	17.9	18.6	20.3	-
		S/T	0.71	0.59	0.41	-	0.73	0.61	0.42	-	0.75	0.63	0.44	-	0.78	0.65	0.45	-	0.81	0.67	0.47	-	0.81	0.68	0.47	-
		ΔT	17	15	11	-	17	15	11	-	17	15	11	-	17	15	11	-	17	15	11	-	16	14	10	-
744	kW	1.58	1.61	1.66	-	1.70	1.73	1.79	-	1.80	1.84	1.90	-	1.89	1.93	1.99	-	1.97	2.01	2.07	-	2.03	2.08	2.14	-	
	Amps	5.8	5.9	6.1	-	6.2	6.4	6.6	-	6.8	6.9	7.2	-	7.2	7.4	7.7	-	7.7	7.9	8.1	-	8.2	8.4	8.6	-	
	Hi-PR	139	149	158	-	156	168	177	-	177	191	202	-	202	217	229	-	227	244	258	-	251	270	285	-	
	Lo-PR	61	65	71	-	65	69	75	-	67	71	78	-	70	75	82	-	74	79	86	-	76	81	89	-	
	MBh	20.2	20.9	22.9	-	19.7	20.4	22.4	-	19.3	20.0	21.9	-	18.8	19.5	21.3	-	17.8	18.5	20.3	-	16.5	17.1	18.8	-	
744	S/T	0.68	0.57	0.40	-	0.71	0.59	0.41	-	0.73	0.61	0.42	-	0.75	0.63	0.43	-	0.78	0.65	0.45	-	0.78	0.65	0.45	-	
	ΔT	17	15	11	-	17	15	11	-	17	15	11	-	17	15	11	-	17	15	11	-	16	14	11	-	
	kW	1.55	1.58	1.62	-	1.66	1.69	1.74	-	1.76	1.79	1.85	-	1.85	1.88	1.94	-	1.92	1.96	2.02	-	1.98	2.03	2.09	-	
	Amps	5.6	5.7	5.9	-	6.1	6.2	6.4	-	6.6	6.7	7.0	-	7.0	7.2	7.4	-	7.5	7.7	7.9	-	7.9	8.1	8.4	-	
	Hi-PR	135	145	153	-	151	163	172	-	172	185	195	-	196	211	222	-	220	237	250	-	243	262	276	-	
Lo-PR	59	63	69	-	63	67	73	-	65	69	76	-	68	73	79	-	72	76	83	-	74	79	86	-		

75	956	MBh	22.92	23.60	25.54	27.41	22.39	23.05	24.95	26.78	21.85	22.50	24.36	26.14	21.32	21.95	23.76	25.50	20.25	20.85	22.57	24.23	18.76	19.32	20.91	22.44
		S/T	0.84	0.75	0.57	0.37	0.87	0.78	0.59	0.38	0.90	0.80	0.61	0.39	0.93	0.83	0.63	0.40	0.96	0.86	0.65	0.42	0.97	0.87	0.66	0.42
		ΔT	19	17	14	10	19	17	14	10	19	17	14	10	19	17	14	10	19	17	14	10	17	16	13	9
		kW	1.61	1.64	1.69	1.74	1.72	1.76	1.81	1.87	1.83	1.87	1.93	1.99	1.92	1.96	2.02	2.09	2.00	2.04	2.11	2.18	2.07	2.11	2.18	2.25
		Amps	5.9	6.0	6.2	6.4	6.3	6.5	6.7	7.0	6.9	7.1	7.3	7.6	7.4	7.5	7.8	8.1	7.8	8.0	8.3	8.6	8.3	8.5	8.8	9.1
	850	Hi-PR	142	152	161	168	159	171	181	188	181	195	205	214	206	222	234	244	232	249	263	275	256	275	291	303
		Lo-PR	62	66	72	77	66	70	76	81	68	73	79	85	72	76	83	89	75	80	87	93	78	83	91	96
		MBh	22.3	22.9	24.8	26.6	21.7	22.4	24.2	26.0	21.2	21.8	23.6	25.4	20.7	21.3	23.1	24.8	19.7	20.2	21.9	23.5	18.2	18.8	20.3	21.8
		S/T	0.80	0.72	0.54	0.35	0.83	0.75	0.56	0.36	0.86	0.77	0.58	0.37	0.88	0.79	0.60	0.38	0.92	0.82	0.62	0.40	0.92	0.83	0.63	0.40
		ΔT	19	18	15	10	20	18	15	10	20	18	15	10	20	18	15	10	19	18	15	10	18	17	14	9
744	kW	1.60	1.63	1.68	1.73	1.71	1.75	1.80	1.86	1.81	1.85	1.91	1.97	1.91	1.95	2.01	2.07	1.98	2.03	2.09	2.16	2.05	2.09	2.16	2.23	
	Amps	5.8	6.0	6.2	6.4	6.3	6.4	6.7	6.9	6.8	7.0	7.2	7.5	7.3	7.5	7.7	8.0	7.8	8.0	8.2	8.5	8.2	8.4	8.7	9.1	
	Hi-PR	140	151	159	166	157	169	179	187	179	193	203	212	204	219	232	242	229	247	261	272	253	273	288	300	
	Lo-PR	62	66	72	76	65	69	76	81	68	72	79	84	71	76	83	88	75	79	87	92	77	82	90	95	
	MBh	20.5	21.1	22.9	24.6	20.1	20.7	22.4	24.0	19.6	20.2	21.8	23.4	19.1	19.6	21.3	22.9	18.2	18.7	20.2	21.7	16.8	17.3	18.7	20.1	
744	S/T	0.78	0.69	0.53	0.34	0.80	0.72	0.54	0.35	0.82	0.74	0.56	0.36	0.85	0.76	0.58	0.37	0.88	0.79	0.60	0.38	0.89	0.80	0.60	0.39	
	ΔT	20	18	15	10	20	18	15	10	20	18	15	10	20	19	15	10	20	18	15	10	19	17	14	10	
	kW	1.56	1.59	1.64	1.69	1.67	1.71	1.76	1.81	1.77	1.81	1.86	1.92	1.86	1.90	1.96	2.02	1.94	1.98	2.04	2.11	2.00	2.04	2.11	2.18	
	Amps	5.7	5.8	6.0	6.2	6.1	6.3	6.5	6.7	6.6	6.8	7.0	7.3	7.1	7.3	7.5	7.8	7.6	7.7	8.0	8.3	8.0	8.2	8.5	8.8	
	Hi-PR	136	146	155	161	153	164	173	181	174	187	197	206	198	213	225	234	222	239	253	264	246	265	279	291	
Lo-PR	60	64	70	74	63	67	73	78	66	70	76	81	69	73	80	85	72	77	84	89	75	80	87	93		

IDB: Entering Indoor Dry Bulb Temperature kW = Total system power Shaded area reflects ACCA (TVA) conditions Amps = outdoor unit amps (comp.+fan)
 High and low pressures are measured at the liquid and suction service valves. Design Subcooling ± 3 °F @ the liquid service valve, ARI 95 test conditions

EXPANDED COOLING DATA — GSH130241B* / AR*F182416** (CONT.)

IDB	Airflow	Outdoor Ambient Temperature																								
		65°F				75°F				85°F				95°F				105°F				115°F				
		59	63	67	71	59	63	67	71	59	63	67	71	59	63	67	71	59	63	67	71	59	63	67	71	
80	956	MBh	23.33	23.84	25.47	27.22	22.79	23.28	24.87	26.59	22.24	22.73	24.28	25.96	21.70	22.17	23.69	25.32	20.62	21.07	22.51	24.06	19.10	19.51	20.85	22.29
		S/T	0.93	0.87	0.71	0.53	0.96	0.90	0.73	0.55	1.00	0.92	0.75	0.56	1.00	0.95	0.78	0.58	1.00	1.00	0.80	0.60	1.00	1.00	0.81	0.61
		ΔT	21	20	17	14	21	20	18	14	21	20	18	14	21	20	18	14	20	20	17	14	18	19	16	13
		kW	1.62	1.65	1.70	1.75	1.74	1.77	1.83	1.89	1.84	1.88	1.94	2.00	1.94	1.98	2.04	2.11	2.02	2.06	2.12	2.19	2.08	2.13	2.20	2.27
		Amps	5.9	6.1	6.3	6.5	6.4	6.6	6.8	7.0	7.0	7.1	7.4	7.6	7.4	7.6	7.9	8.2	7.9	8.1	8.4	8.7	8.4	8.6	8.9	9.2
		Hi/PR	143	154	163	170	161	173	182	190	183	197	208	216	208	224	236	247	234	252	266	277	259	278	294	306
	Lo/PR	63	67	73	78	67	71	77	82	69	74	80	86	73	77	84	90	76	81	88	94	79	84	91	97	
	850	MBh	22.6	23.1	24.7	26.4	22.1	22.6	24.2	25.8	21.6	22.1	23.6	25.2	21.1	21.5	23.0	24.6	20.0	20.5	21.9	23.4	18.5	18.9	20.2	21.6
		S/T	0.88	0.83	0.67	0.50	0.91	0.86	0.70	0.52	0.94	0.88	0.72	0.54	0.97	0.91	0.74	0.55	1.00	0.94	0.77	0.57	1.00	0.95	0.77	0.58
		ΔT	22	21	18	14	22	21	18	15	22	21	18	15	22	21	18	15	22	21	18	14	20	19	17	14
		kW	1.61	1.64	1.69	1.74	1.73	1.76	1.81	1.87	1.83	1.87	1.93	1.99	1.92	1.96	2.02	2.09	2.00	2.04	2.11	2.18	2.07	2.11	2.18	2.25
		Amps	5.9	6.0	6.2	6.4	6.3	6.5	6.7	7.0	6.9	7.1	7.3	7.6	7.4	7.5	7.8	8.1	7.8	8.0	8.3	8.6	8.3	8.5	8.8	9.1
Hi/PR		142	152	161	168	159	171	181	188	181	195	205	214	206	222	234	244	232	249	263	275	256	275	291	303	
Lo/PR	62	66	72	77	66	70	76	81	68	73	79	85	72	76	84	89	75	80	88	93	78	83	91	96		
744	MBh	20.9	21.4	22.8	24.4	20.4	20.9	22.3	23.8	19.9	20.4	21.8	23.3	19.4	19.9	21.2	22.7	18.5	18.9	20.2	21.6	17.1	17.5	18.7	20.0	
	S/T	0.85	0.80	0.65	0.49	0.88	0.83	0.67	0.50	0.90	0.85	0.69	0.52	0.93	0.88	0.71	0.53	0.97	0.91	0.74	0.55	0.98	0.92	0.75	0.56	
	ΔT	22	21	18	15	22	21	19	15	22	21	19	15	22	22	19	15	22	21	18	15	21	20	17	14	
	kW	1.57	1.60	1.65	1.70	1.69	1.72	1.77	1.83	1.79	1.82	1.88	1.94	1.88	1.91	1.97	2.04	1.95	1.99	2.06	2.12	2.02	2.06	2.13	2.19	
	Amps	5.7	5.9	6.0	6.3	6.2	6.3	6.5	6.8	6.7	6.9	7.1	7.4	7.2	7.3	7.6	7.9	7.6	7.8	8.1	8.4	8.1	8.3	8.6	8.9	
	Hi/PR	137	148	156	163	154	166	175	183	175	189	199	208	200	215	227	237	225	242	255	266	248	267	282	294	
Lo/PR	60	64	70	75	64	68	74	79	66	71	77	82	70	74	81	86	73	78	85	90	76	80	88	94		

85	956	MBh	23.74	24.19	25.34	27.03	23.18	23.63	24.75	26.40	22.63	23.07	24.16	25.78	22.08	22.51	23.57	25.15	20.98	21.38	22.39	23.89	19.43	19.81	20.74	22.13
		S/T	0.97	0.94	0.84	0.69	1.00	0.97	0.88	0.71	1.00	0.99	0.90	0.73	1.00	1.00	0.93	0.75	1.00	1.00	0.96	0.78	1.00	1.00	0.97	0.79
		ΔT	22	22	21	18	22	22	21	18	22	22	21	18	21	22	21	18	20	21	21	18	19	19	19	17
		kW	1.63	1.66	1.72	1.77	1.75	1.79	1.84	1.90	1.86	1.90	1.96	2.02	1.95	1.99	2.06	2.12	2.03	2.08	2.14	2.21	2.10	2.15	2.22	2.29
		Amps	6.0	6.1	6.3	6.6	6.5	6.6	6.8	7.1	7.0	7.2	7.4	7.7	7.5	7.7	7.9	8.2	8.0	8.2	8.5	8.8	8.5	8.7	9.0	9.3
		Hi/PR	145	156	164	171	162	175	184	192	184	198	210	219	210	226	239	249	236	254	269	280	261	281	297	309
	Lo/PR	64	68	74	79	67	71	78	83	70	74	81	86	73	78	85	91	77	82	89	95	79	85	92	98	
	850	MBh	23.0	23.5	24.6	26.2	22.5	22.9	24.0	25.6	22.0	22.4	23.5	25.0	21.4	21.9	22.9	24.4	20.4	20.8	21.7	23.2	18.9	19.2	20.1	21.5
		S/T	0.93	0.89	0.81	0.65	0.96	0.93	0.84	0.68	0.98	0.95	0.86	0.69	1.00	0.98	0.88	0.72	1.00	1.00	0.92	0.74	1.00	1.00	0.93	0.75
		ΔT	23	23	21	19	23	23	22	19	23	23	22	19	23	23	22	19	22	22	22	19	20	21	20	17
		kW	1.62	1.65	1.70	1.75	1.74	1.77	1.83	1.89	1.84	1.88	1.94	2.00	1.94	1.98	2.04	2.11	2.02	2.06	2.12	2.19	2.08	2.13	2.20	2.27
		Amps	5.9	6.1	6.3	6.5	6.4	6.6	6.8	7.0	7.0	7.1	7.4	7.6	7.4	7.6	7.9	8.2	7.9	8.1	8.4	8.7	8.4	8.6	8.9	9.2
Hi/PR		143	154	163	170	161	173	182	190	183	197	208	216	208	224	236	247	234	252	266	277	259	278	294	306	
Lo/PR	63	67	73	78	67	71	77	82	69	74	80	86	73	77	84	90	76	81	88	94	79	84	91	97		
744	MBh	21.3	21.7	22.7	24.2	20.8	21.2	22.2	23.7	20.3	20.7	21.7	23.1	19.8	20.2	21.1	22.5	18.8	19.2	20.1	21.4	17.4	17.7	18.6	19.8	
	S/T	0.89	0.86	0.78	0.63	0.92	0.89	0.81	0.65	0.95	0.91	0.83	0.67	0.98	0.94	0.85	0.69	1.00	0.98	0.88	0.72	1.00	0.99	0.89	0.72	
	ΔT	23	23	22	19	24	23	22	19	24	23	22	19	24	24	22	19	23	23	22	19	22	22	20	18	
	kW	1.58	1.61	1.66	1.71	1.70	1.73	1.79	1.84	1.80	1.84	1.89	1.95	1.89	1.93	1.99	2.05	1.97	2.01	2.07	2.14	2.03	2.08	2.14	2.21	
	Amps	5.8	5.9	6.1	6.3	6.2	6.4	6.6	6.8	6.8	6.9	7.2	7.4	7.2	7.4	7.7	7.9	7.7	7.9	8.1	8.5	8.2	8.4	8.6	9.0	
	Hi/PR	139	149	158	165	156	168	177	185	177	191	201	210	202	217	229	239	227	244	258	269	251	270	285	297	
Lo/PR	61	65	71	76	65	69	75	80	67	71	78	83	70	75	82	87	74	79	86	91	76	81	89	94		

IDB: Entering Indoor Dry Bulb Temperature kW = Total system power Shaded area reflects ARI Rating conditions Amps = outdoor unit amps (comp. -fan)
 High and low pressures are measured at the liquid and suction service valves. Design Subcooling ± 3 °F @ the liquid service valve, ARI 95 test conditions

EXPANDED COOLING DATA — GSH130251A* / AWUF36XX1A*

IDB	Airflow	Outdoor Ambient Temperature																							
		65°F				75°F				85°F				95°F				105°F				115°F			
		59	63	67	71	59	63	67	71	59	63	67	71	59	63	67	71	59	63	67	71	59	63	67	71
70	MBh	23.5	24.4	26.7	-	23.0	23.8	26.1	-	22.4	23.2	25.5	-	21.9	22.7	24.8	-	20.8	21.5	23.6	-	19.3	20.0	21.9	-
	S/T	0.74	0.62	0.43	-	0.77	0.64	0.44	-	0.79	0.66	0.45	-	0.81	0.68	0.47	-	0.84	0.70	0.49	-	0.85	0.71	0.49	-
	ΔT	17	15	11	-	18	15	12	-	18	15	12	-	18	15	12	-	17	15	11	-	16	14	11	-
	kW	1.68	1.71	1.76	-	1.79	1.83	1.88	-	1.90	1.93	1.99	-	1.99	2.03	2.09	-	2.06	2.11	2.17	-	2.13	2.18	2.24	-
	Amps	6.7	6.8	7.0	-	7.2	7.3	66.0	-	7.7	7.9	8.1	-	8.2	8.4	8.6	-	8.7	8.9	9.1	-	9.1	9.3	9.6	-
	Hi PR	139	150	158	-	156	168	177	-	177	191	202	-	202	217	230	-	227	245	258	-	251	270	285	-
	Lo PR	59	63	69	-	63	67	73	-	65	69	76	-	68	73	80	-	72	76	83	-	74	79	86	-
	MBh	22.8	23.7	25.9	-	22.3	23.1	25.3	-	21.8	22.6	24.7	-	21.2	22.0	24.1	-	20.2	20.9	22.9	-	18.7	19.4	21.2	-
	S/T	0.71	0.59	0.41	-	0.73	0.61	0.42	-	0.75	0.63	0.43	-	0.77	0.65	0.45	-	0.80	0.67	0.46	-	0.81	0.68	0.47	-
	ΔT	18	16	12	-	18	16	12	-	18	16	12	-	18	16	12	-	18	16	12	-	17	15	11	-
kW	1.66	1.70	1.74	-	1.78	1.81	1.87	-	1.88	1.92	1.98	-	1.97	2.01	2.07	-	2.05	2.09	2.15	-	2.11	2.16	2.23	-	
Amps	6.6	6.8	7.0	-	7.1	7.3	7.5	-	7.6	7.8	8.0	-	8.1	8.3	8.5	-	8.6	8.8	9.0	-	9.0	9.3	9.5	-	
Hi PR	138	148	156	-	154	166	175	-	176	189	200	-	200	215	227	-	225	242	256	-	249	267	282	-	
Lo PR	59	63	68	-	62	66	72	-	65	69	75	-	68	72	79	-	71	76	83	-	73	78	85	-	
MBh	21.1	21.8	23.9	-	20.6	21.3	23.4	-	20.1	20.8	22.8	-	19.6	20.3	22.3	-	18.6	19.3	21.1	-	17.3	17.9	19.6	-	
S/T	0.68	0.57	0.39	-	0.70	0.59	0.41	-	0.72	0.60	0.42	-	0.75	0.62	0.43	-	0.77	0.65	0.45	-	0.78	0.65	0.45	-	
ΔT	18	16	12	-	19	16	12	-	19	16	12	-	19	16	12	-	18	16	12	-	17	15	11	-	
kW	1.63	1.66	1.71	-	1.74	1.77	1.83	-	1.84	1.88	1.93	-	1.93	1.97	2.02	-	2.00	2.04	2.10	-	2.07	2.11	2.17	-	
Amps	6.5	6.6	6.8	-	6.9	7.1	7.3	-	7.5	7.6	7.8	-	7.9	8.1	8.3	-	8.4	8.6	8.8	-	8.8	9.0	9.3	-	
Hi PR	133	144	152	-	150	161	170	-	170	183	194	-	194	209	220	-	218	235	248	-	241	259	274	-	
Lo PR	57	61	66	-	60	64	70	-	63	67	73	-	66	70	76	-	69	73	80	-	71	76	83	-	

75	MBh	23.9	24.6	26.7	28.6	23.4	24.1	26.0	27.9	22.8	23.5	25.4	27.3	22.2	22.9	24.8	26.6	21.1	21.8	23.6	25.3	19.6	20.2	21.8	23.4
	S/T	0.84	0.75	0.57	0.37	0.87	0.78	0.59	0.38	0.89	0.80	0.60	0.39	0.92	0.82	0.62	0.40	0.96	0.86	0.65	0.42	0.97	0.86	0.65	0.42
	ΔT	20	18	15	10	20	19	15	11	20	19	15	11	20	19	15	11	20	19	15	11	19	17	14	10
	kW	1.69	1.72	1.77	1.82	1.81	1.84	1.90	1.95	1.91	1.95	2.01	2.07	2.00	2.04	2.11	2.17	2.08	2.12	2.19	2.26	2.15	2.19	2.26	2.33
	Amps	6.7	6.9	7.1	7.3	7.2	7.4	7.6	7.8	7.8	7.9	8.2	8.5	8.3	8.4	8.7	9.0	8.7	8.9	9.2	9.5	9.2	9.4	9.7	10.0
	Hi PR	140	151	160	166	158	170	179	187	179	193	204	212	204	220	232	242	230	247	261	272	254	273	288	301
	Lo PR	60	64	70	74	63	67	74	78	66	70	76	81	69	74	80	86	72	77	84	90	75	80	87	93
	MBh	23.2	23.9	25.9	27.8	22.7	23.4	25.3	27.1	22.1	22.8	24.7	26.5	21.6	22.2	24.1	25.8	20.5	21.1	22.9	24.5	19.0	19.6	21.2	22.7
	S/T	0.80	0.72	0.54	0.35	0.83	0.74	0.56	0.36	0.85	0.76	0.58	0.37	0.88	0.79	0.60	0.38	0.91	0.82	0.62	0.40	0.92	0.82	0.62	0.40
	ΔT	21	19	16	11	21	19	16	11	21	19	16	11	21	20	16	11	21	19	16	11	20	18	15	10
kW	1.68	1.71	1.76	1.81	1.79	1.83	1.88	1.94	1.90	1.93	1.99	2.05	1.99	2.03	2.09	2.15	2.06	2.11	2.17	2.24	2.13	2.18	2.24	2.31	
Amps	6.7	6.8	7.0	7.3	7.2	7.3	7.5	7.8	7.7	7.9	8.1	8.4	8.2	8.4	8.6	8.9	8.7	8.9	9.1	9.4	9.1	9.3	9.6	10.0	
Hi PR	139	150	158	165	156	168	177	185	177	191	202	210	202	217	230	239	227	245	258	269	251	270	285	298	
Lo PR	59	63	69	73	63	67	73	78	65	69	76	81	68	73	80	85	72	76	83	89	74	79	86	92	
MBh	21.4	22.1	23.9	25.6	20.9	21.6	23.3	25.0	20.4	21.0	22.8	24.4	19.9	20.5	22.2	23.8	18.9	19.5	21.1	22.7	17.5	18.1	19.6	21.0	
S/T	0.77	0.69	0.52	0.34	0.80	0.72	0.54	0.35	0.82	0.73	0.56	0.36	0.85	0.76	0.57	0.37	0.88	0.79	0.60	0.38	0.89	0.79	0.60	0.39	
ΔT	21	20	16	11	21	20	16	11	22	20	16	11	22	20	16	11	21	20	16	11	20	18	15	10	
kW	1.64	1.67	1.72	1.77	1.75	1.79	1.84	1.89	1.85	1.89	1.95	2.01	1.94	1.98	2.04	2.10	2.02	2.06	2.12	2.19	2.08	2.12	2.19	2.26	
Amps	6.5	6.7	6.9	7.1	7.0	7.1	7.3	7.6	7.5	7.7	7.9	8.2	8.0	8.2	8.4	8.7	8.4	8.6	8.9	9.2	8.9	9.1	9.4	9.7	
Hi PR	135	145	153	160	151	163	172	179	172	185	196	204	196	211	223	232	220	237	251	261	244	262	277	289	
Lo PR	58	61	67	71	61	65	71	75	63	67	73	78	66	71	77	82	70	74	81	86	72	77	84	89	

IDB: Entering Indoor Dry Bulb Temperature kW = Total system power Shaded area reflects ACCA (TVA) conditions Amps = outdoor unit amps (comp.+fan)
 High and low pressures are measured at the liquid and suction service valves. Design Subcooling 9 ±3 °F @ the liquid service valve, ARI 95 test conditions

EXPANDED COOLING DATA — GSH130251A* / AWUF36XX1A* (CONT.)

IDB	Airflow	Outdoor Ambient Temperature																								
		65°F				75°F				85°F				95°F				105°F				115°F				
		59	63	67	71	59	63	67	71	59	63	67	71	59	63	67	71	59	63	67	71	59	63	67	71	
80	923	MBh	24.3	24.9	26.6	28.4	23.8	24.3	26.0	27.7	23.2	23.7	25.3	27.1	22.6	23.1	24.7	26.4	21.5	22.0	23.5	25.1	19.9	20.4	21.8	23.3
		S/T	0.92	0.86	0.70	0.53	0.96	0.90	0.73	0.55	1.00	0.92	0.75	0.56	1.00	0.95	0.77	0.58	1.00	1.00	0.80	0.60	1.00	1.00	0.81	0.60
	ΔT	22	21	19	15	23	22	19	15	23	22	19	15	23	22	19	15	21	22	19	15	20	20	18	14	
	kW	1.70	1.73	1.78	1.84	1.82	1.86	1.91	1.97	1.92	1.96	2.02	2.08	2.02	2.06	2.12	2.19	2.10	2.14	2.21	2.28	2.16	2.21	2.28	2.35	
	Amps	6.8	6.9	7.1	7.4	7.3	7.4	7.7	7.9	7.8	8.0	8.2	8.5	8.3	8.5	8.8	9.1	8.8	9.0	9.3	9.6	9.3	9.5	9.8	10.1	
	Hi PR	142	153	161	168	159	171	181	189	181	195	206	214	206	222	234	244	232	250	263	275	256	276	291	304	
	Lo PR	61	64	70	75	64	68	74	79	67	71	77	82	70	74	81	86	73	78	85	91	76	81	88	94	
	820	MBh	23.6	24.1	25.8	27.6	23.1	23.6	25.2	26.9	22.5	23.0	24.6	26.3	22.0	22.5	24.0	25.7	20.9	21.3	22.8	24.4	19.3	19.8	21.1	22.6
		S/T	0.88	0.82	0.67	0.50	0.91	0.85	0.70	0.52	0.93	0.88	0.71	0.53	0.96	0.90	0.74	0.55	1.00	0.94	0.76	0.57	1.00	0.95	0.77	0.58
	718	923	MBh	1.69	1.72	1.77	1.82	1.81	1.84	1.90	1.95	1.91	1.95	2.01	2.07	2.00	2.04	2.11	2.17	2.08	2.12	2.19	2.26	2.15	2.19	2.26
S/T			6.7	6.9	7.1	7.3	7.2	7.4	7.6	7.8	7.8	7.9	8.2	8.5	8.3	8.4	8.7	9.0	8.7	8.9	9.2	9.5	9.2	9.4	9.7	10.0
ΔT		140	151	160	166	158	170	179	187	179	193	204	212	204	220	232	242	230	247	261	272	254	273	288	301	
kW		60	64	70	74	63	67	74	78	66	70	76	81	69	74	80	86	72	77	84	90	75	80	87	93	
Amps		21.8	22.3	23.8	25.5	21.3	21.8	23.3	24.9	20.8	21.3	22.7	24.3	20.3	20.7	22.2	23.7	19.3	19.7	21.0	22.5	17.9	18.2	19.5	20.8	
Hi PR		0.85	0.80	0.65	0.48	0.88	0.82	0.67	0.50	0.90	0.85	0.69	0.51	0.93	0.87	0.71	0.53	0.97	0.91	0.74	0.55	0.97	0.91	0.74	0.56	
Lo PR		24	23	20	16	24	23	20	16	24	23	20	16	24	23	20	16	24	23	20	16	22	21	19	15	
820		MBh	1.65	1.68	1.73	1.78	1.77	1.80	1.85	1.91	1.87	1.90	1.96	2.02	1.96	2.00	2.06	2.12	2.03	2.07	2.14	2.20	2.10	2.14	2.21	2.28
		S/T	6.6	6.7	6.9	7.1	7.0	7.2	7.4	7.7	7.6	7.7	8.0	8.2	8.0	8.2	8.5	8.8	8.5	8.7	9.0	9.3	9.0	9.2	9.5	9.8
85		923	MBh	24.8	25.2	26.4	28.2	24.2	24.7	25.8	27.6	23.6	24.1	25.2	26.9	23.0	23.5	24.6	26.2	21.9	22.3	23.4	24.9	20.3	20.7	21.6
	S/T		0.97	0.93	0.84	0.68	1.00	0.97	0.87	0.71	1.00	0.99	0.89	0.73	1.00	1.00	0.92	0.75	1.00	1.00	0.96	0.78	1.00	1.00	0.97	0.78
85	820	MBh	1.71	1.75	1.80	1.85	1.83	1.87	1.92	1.98	1.94	1.98	2.04	2.10	2.03	2.07	2.14	2.21	2.11	2.16	2.22	2.29	2.18	2.23	2.30	2.37
		S/T	6.8	7.0	7.2	7.4	7.3	7.5	7.7	8.0	7.9	8.1	8.3	8.6	8.4	8.6	8.8	9.1	8.9	9.1	9.4	9.7	9.4	9.6	9.9	10.2
	ΔT	143	154	163	170	161	173	183	190	183	197	208	217	208	224	237	247	234	252	266	278	259	278	294	307	
	kW	61	65	71	76	65	69	75	80	67	71	78	83	71	75	82	87	74	79	86	91	76	81	89	95	
	Amps	24.0	24.5	25.7	27.4	23.5	23.9	25.1	26.8	22.9	23.4	24.5	26.1	22.4	22.8	23.9	25.5	21.2	21.7	22.7	24.2	19.7	20.1	21.0	22.4	
	Hi PR	0.92	0.89	0.80	0.65	0.96	0.92	0.83	0.67	0.98	0.95	0.85	0.69	1.00	0.98	0.88	0.71	1.00	1.00	0.91	0.74	1.00	1.00	0.92	0.75	
	Lo PR	25	24	23	20	25	25	23	20	25	25	23	20	25	25	24	20	24	24	23	20	22	22	22	19	
	718	MBh	1.70	1.73	1.78	1.84	1.82	1.86	1.91	1.97	1.92	1.96	2.02	2.08	2.02	2.06	2.12	2.19	2.10	2.14	2.21	2.28	2.16	2.21	2.28	2.35
		S/T	6.8	6.9	7.1	7.4	7.3	7.4	7.7	7.9	7.8	8.0	8.2	8.5	8.3	8.5	8.8	9.1	8.8	9.0	9.3	9.6	9.3	9.5	9.8	10.1
	85	923	MBh	22.2	22.6	23.7	25.3	21.7	22.1	23.1	24.7	21.2	21.6	22.6	24.1	20.6	21.0	22.0	23.5	19.6	20.0	20.9	22.3	18.2	18.5	19.4
S/T			0.89	0.86	0.77	0.63	0.92	0.89	0.80	0.65	0.94	0.91	0.82	0.67	0.98	0.94	0.85	0.69	1.00	0.98	0.88	0.71	1.00	0.98	0.89	0.72
85	820	MBh	25	25	24	20	26	25	24	21	26	25	24	21	26	25	24	21	25	25	24	20	23	23	22	19
		S/T	1.66	1.69	1.74	1.79	1.78	1.81	1.87	1.92	1.88	1.92	1.98	2.04	1.97	2.01	2.07	2.14	2.05	2.09	2.15	2.22	2.11	2.16	2.22	2.30
	ΔT	6.6	6.8	7.0	7.2	7.1	7.3	7.5	7.7	7.6	7.8	8.0	8.3	8.1	8.3	8.5	8.8	8.6	8.8	9.0	9.4	9.0	9.3	9.5	9.9	
	kW	138	148	156	163	154	166	175	183	176	189	199	208	200	215	227	237	225	242	256	267	248	267	282	295	
	Amps	59	63	68	73	62	66	72	77	65	69	75	80	68	72	79	84	71	76	82	88	73	78	85	91	
	Hi PR	138	148	156	163	154	166	175	183	176	189	199	208	200	215	227	237	225	242	256	267	248	267	282	295	
	Lo PR	59	63	68	73	62	66	72	77	65	69	75	80	68	72	79	84	71	76	82	88	73	78	85	91	

IDB: Entering Indoor Dry Bulb Temperature kW = Total system power Shaded area reflects ARI Rating conditions Amps = outdoor unit amps (comp.+fan)
 High and low pressures are measured at the liquid and suction service valves. Design Subcooling 9 ±3 °F @ the liquid service valve, ARI 95 test conditions

EXPANDED COOLING DATA — GSH130301A* / ARUF42-00*-01* / ARUF30301A*

IDB	Airflow	Outdoor Ambient Temperature																							
		65°F				75°F				85°F				95°F				105°F				115°F			
		59	63	67	71	59	63	67	71	59	63	67	71	59	63	67	71	59	63	67	71	59	63	67	71
1173	MBh	27.0	28.0	30.7	-	26.4	27.4	30.0	-	25.8	26.7	29.3	-	25.2	26.1	28.6	-	23.9	24.8	27.1	-	22.1	22.9	25.1	-
	S/T	0.75	0.63	0.43	-	0.78	0.65	0.45	-	0.80	0.67	0.46	-	0.82	0.69	0.48	-	0.85	0.71	0.49	-	0.86	0.72	0.50	-
	ΔT	16	14	10	-	16	14	11	-	16	14	11	-	16	14	11	-	16	14	11	-	15	13	10	-
	kW	2.04	2.08	2.14	-	2.19	2.24	2.31	-	2.32	2.37	2.45	-	2.44	2.49	2.57	-	2.54	2.60	2.68	-	2.63	2.69	2.77	-
	Amps	7.6	7.8	8.1	-	8.2	8.4	8.7	-	9.0	9.2	9.5	-	9.6	9.8	10.2	-	10.2	10.5	10.8	-	10.8	11.1	11.5	-
	Hi PR	141	152	161	-	159	171	180	-	181	194	205	-	206	221	234	-	231	249	263	-	256	275	290	-
	Lo PR	62	66	73	-	66	70	77	-	69	73	80	-	72	77	84	-	75	80	88	-	78	83	91	-
	MBh	26.6	27.6	30.3	-	26.0	27.0	29.5	-	25.4	26.3	28.8	-	24.8	25.7	28.1	-	23.5	24.4	26.7	-	21.8	22.6	24.8	-
	S/T	0.72	0.60	0.42	-	0.74	0.62	0.43	-	0.76	0.64	0.44	-	0.79	0.66	0.46	-	0.82	0.68	0.47	-	0.82	0.69	0.48	-
	ΔT	17	15	11	-	17	15	11	-	17	15	11	-	17	15	11	-	17	15	11	-	16	14	10	-
70	kW	2.03	2.07	2.13	-	2.18	2.22	2.29	-	2.31	2.36	2.43	-	2.43	2.48	2.56	-	2.53	2.58	2.67	-	2.61	2.67	2.76	-
	Amps	7.6	7.8	8.0	-	8.2	8.4	8.7	-	8.9	9.1	9.4	-	9.5	9.8	10.1	-	10.1	10.4	10.7	-	10.8	11.0	11.4	-
	Hi PR	140	151	160	-	158	170	179	-	179	193	204	-	204	220	232	-	230	247	261	-	254	273	288	-
	Lo PR	62	66	72	-	66	70	76	-	68	72	79	-	72	76	83	-	75	80	87	-	78	82	90	-
	MBh	25.3	26.2	28.7	-	24.7	25.6	28.1	-	24.1	25.0	27.4	-	23.5	24.4	26.7	-	22.4	23.2	25.4	-	20.7	21.5	23.5	-
	S/T	0.69	0.57	0.40	-	0.71	0.60	0.41	-	0.73	0.61	0.42	-	0.75	0.63	0.44	-	0.78	0.65	0.45	-	0.79	0.66	0.46	-
	ΔT	17	15	11	-	17	15	11	-	18	15	12	-	18	15	12	-	17	15	11	-	16	14	11	-
	kW	2.00	2.04	2.10	-	2.14	2.19	2.26	-	2.27	2.32	2.40	-	2.39	2.44	2.52	-	2.49	2.54	2.62	-	2.57	2.63	2.71	-
	Amps	7.4	7.6	7.9	-	8.0	8.2	8.5	-	8.7	9.0	9.3	-	9.3	9.6	9.9	-	10.0	10.2	10.5	-	10.6	10.8	11.2	-
	Hi PR	138	148	156	-	154	166	176	-	176	189	200	-	200	215	227	-	225	242	256	-	249	268	283	-
Lo PR	61	65	71	-	64	68	75	-	67	71	78	-	70	75	81	-	73	78	85	-	76	81	88	-	

1173	MBh	27.5	28.3	30.6	32.9	26.9	27.7	29.9	32.1	26.2	27.0	29.2	31.4	25.6	26.3	28.5	30.6	24.3	25.0	27.1	29.1	22.5	23.2	25.1	26.9
	S/T	0.85	0.76	0.58	0.37	0.88	0.79	0.60	0.38	0.91	0.81	0.61	0.39	0.94	0.84	0.63	0.41	0.97	0.87	0.66	0.42	0.98	0.88	0.66	0.43
	ΔT	18	17	14	10	19	17	14	10	19	17	14	10	19	17	14	10	18	17	14	10	17	16	13	9
	kW	2.05	2.10	2.16	2.23	2.21	2.25	2.32	2.40	2.34	2.39	2.47	2.55	2.46	2.52	2.60	2.68	2.56	2.62	2.70	2.79	2.65	2.71	2.80	2.89
	Amps	7.7	7.9	8.1	8.4	8.3	8.5	8.8	9.1	9.0	9.3	9.6	9.9	9.7	9.9	10.3	10.6	10.3	10.6	10.9	11.3	10.9	11.2	11.6	12.0
	Hi PR	143	154	162	169	160	173	182	190	182	196	207	216	208	224	236	246	234	251	266	277	258	278	293	306
	Lo PR	63	67	73	78	67	71	77	82	69	74	80	86	73	77	85	90	76	81	89	94	79	84	92	98
	MBh	27.1	27.9	30.2	32.4	26.5	27.2	29.5	31.6	25.8	26.6	28.8	30.9	25.2	25.9	28.1	30.1	23.9	24.6	26.7	28.6	22.2	22.8	24.7	26.5
	S/T	0.82	0.73	0.55	0.36	0.85	0.76	0.57	0.37	0.87	0.78	0.59	0.38	0.90	0.80	0.61	0.39	0.93	0.83	0.63	0.40	0.94	0.84	0.63	0.41
	ΔT	19	18	15	10	20	18	15	10	20	18	15	10	20	18	15	10	19	18	15	10	18	17	14	9
75	kW	2.04	2.08	2.15	2.22	2.19	2.24	2.31	2.38	2.33	2.38	2.45	2.53	2.45	2.50	2.58	2.67	2.55	2.60	2.69	2.78	2.64	2.69	2.78	2.87
	Amps	7.6	7.8	8.1	8.4	8.3	8.5	8.8	9.1	9.0	9.2	9.5	9.9	9.6	9.9	10.2	10.6	10.2	10.5	10.8	11.3	10.9	11.1	11.5	11.9
	Hi PR	142	153	161	168	159	171	181	189	181	195	206	215	206	222	234	244	232	250	264	275	256	276	291	304
	Lo PR	63	67	73	77	66	70	77	82	69	73	80	85	72	77	84	89	76	81	88	94	78	83	91	97
	MBh	25.7	26.5	28.7	30.8	25.1	25.9	28.0	30.1	24.5	25.3	27.3	29.4	23.9	24.6	26.7	28.6	22.7	23.4	25.3	27.2	21.1	21.7	23.5	25.2
	S/T	0.78	0.70	0.53	0.34	0.81	0.73	0.55	0.35	0.83	0.74	0.56	0.36	0.86	0.77	0.58	0.37	0.89	0.80	0.60	0.39	0.90	0.80	0.61	0.39
	ΔT	20	18	15	10	20	19	15	11	20	19	15	11	20	19	15	11	20	19	15	10	19	17	14	10
	kW	2.01	2.05	2.11	2.18	2.16	2.21	2.27	2.35	2.29	2.34	2.41	2.49	2.41	2.46	2.54	2.62	2.51	2.56	2.64	2.73	2.59	2.65	2.74	2.83
	Amps	7.5	7.7	7.9	8.2	8.1	8.3	8.6	8.9	8.8	9.0	9.3	9.7	9.4	9.7	10.0	10.4	10.0	10.3	10.6	11.1	10.7	10.9	11.3	11.7
	Hi PR	139	150	158	165	156	168	177	185	177	191	202	210	202	218	230	240	227	245	258	270	251	270	286	298
Lo PR	61	65	71	76	65	69	75	80	67	72	78	83	71	75	82	88	74	79	86	92	77	82	89	95	

IDB: Entering Indoor Dry Bulb Temperature kW = Total system power Shaded area reflects ACCA (TVA) conditions Amps = outdoor unit amps (comp.+fan)
 High and low pressures are measured at the liquid and suction service valves. Design Subcooling 9 ±3 °F @ the liquid service valve, ARI 95 test conditions

EXPANDED COOLING DATA — GSH130301A* / ARUF42-00*-01* / ARUF30301A* (CONT.)

IDB	Airflow	Outdoor Ambient Temperature																								
		65°F				75°F				85°F				95°F				105°F				115°F				
		59	63	67	71	59	63	67	71	59	63	67	71	59	63	67	71	59	63	67	71	59	63	67	71	
80	1173	MBh	28.0	28.6	30.6	32.7	27.3	27.9	29.8	31.9	26.7	27.3	29.1	31.1	26.0	26.6	28.4	30.4	24.7	25.3	27.0	28.9	22.9	23.4	25.0	26.7
		S/T	0.94	0.88	0.71	0.53	0.97	0.91	0.74	0.55	1.00	0.93	0.76	0.57	1.00	0.96	0.78	0.59	1.00	1.00	0.81	0.61	1.00	1.00	0.82	0.61
		ΔT	21	20	17	14	21	20	17	14	21	20	17	14	20	20	17	14	19	20	17	14	18	18	16	13
		kW	2.07	2.11	2.18	2.25	2.22	2.27	2.34	2.42	2.36	2.41	2.49	2.57	2.48	2.54	2.62	2.70	2.58	2.64	2.73	2.82	2.67	2.73	2.82	2.92
		Amps	7.8	8.0	8.2	8.5	8.4	8.6	8.9	9.2	9.1	9.4	9.7	10.0	9.8	10.0	10.3	10.7	10.4	10.7	11.0	11.4	11.0	11.3	11.7	12.1
	Hi PR	144	155	164	171	162	174	184	192	184	198	209	218	210	226	238	249	236	254	268	280	261	281	296	309	
	Lo PR	64	68	74	79	67	72	78	83	70	74	81	87	74	78	85	91	77	82	89	95	80	85	93	99	
	MBh	27.6	28.2	30.1	32.2	26.9	27.5	29.4	31.4	26.3	26.9	28.7	30.7	25.6	26.2	28.0	29.9	24.4	24.9	26.6	28.4	22.6	23.1	24.6	26.3	
	S/T	0.90	0.84	0.68	0.51	0.93	0.87	0.71	0.53	0.95	0.89	0.73	0.54	0.98	0.92	0.75	0.56	1.00	0.96	0.78	0.58	1.00	0.96	0.78	0.59	
	ΔT	22	21	18	14	22	21	18	15	22	21	18	15	22	21	18	15	21	21	18	14	20	19	17	14	
kW	2.06	2.10	2.17	2.23	2.21	2.26	2.33	2.40	2.35	2.40	2.47	2.55	2.47	2.52	2.60	2.69	2.57	2.63	2.71	2.80	2.66	2.72	2.80	2.90		
Amps	7.7	7.9	8.2	8.5	8.3	8.5	8.8	9.2	9.1	9.3	9.6	10.0	9.7	9.9	10.3	10.7	10.3	10.6	11.0	11.4	11.0	11.2	11.6	12.1		
Hi PR	143	154	163	170	161	173	183	191	183	197	208	217	208	224	237	247	234	252	266	278	259	279	294	307		
Lo PR	63	67	74	78	67	71	78	83	69	74	81	86	73	78	85	90	76	81	89	95	79	84	92	98		
MBh	26.2	26.8	28.6	30.6	25.6	26.1	27.9	29.9	25.0	25.5	27.3	29.1	24.4	24.9	26.6	28.4	23.1	23.7	25.3	27.0	21.4	21.9	23.4	25.0		
S/T	0.86	0.80	0.65	0.49	0.89	0.83	0.68	0.51	0.91	0.86	0.70	0.52	0.94	0.88	0.72	0.54	0.98	0.92	0.75	0.56	0.99	0.92	0.75	0.56		
ΔT	22	21	19	15	23	22	19	15	23	22	19	15	23	22	19	15	22	21	19	15	21	20	17	14		
kW	2.03	2.07	2.13	2.20	2.18	2.22	2.29	2.37	2.31	2.36	2.43	2.51	2.43	2.48	2.56	2.64	2.53	2.58	2.67	2.75	2.61	2.67	2.76	2.85		
Amps	7.6	7.8	8.0	8.3	8.2	8.4	8.7	9.0	8.9	9.1	9.4	9.8	9.5	9.8	10.1	10.5	10.1	10.4	10.7	11.2	10.8	11.0	11.4	11.8		
Hi PR	140	151	160	166	158	170	179	187	179	193	204	212	204	220	232	242	230	247	261	272	254	273	288	301		
Lo PR	62	66	72	77	66	70	76	81	68	72	79	84	72	76	83	88	75	80	87	93	78	82	90	96		

85	1173	MBh	28.5	29.0	30.4	32.4	27.8	28.4	29.7	31.7	27.1	27.7	29.0	30.9	26.5	27.0	28.3	30.2	25.2	25.7	26.9	28.7	23.3	23.8	24.9	26.5
		S/T	0.98	0.95	0.85	0.69	1.00	0.98	0.89	0.72	1.00	1.00	0.91	0.74	1.00	1.00	0.94	0.76	1.00	1.00	0.97	0.79	1.00	1.00	0.98	0.80
		ΔT	22	22	20	18	22	22	21	18	21	22	21	18	21	21	21	18	20	20	20	18	18	19	19	17
		kW	2.09	2.13	2.19	2.26	2.24	2.29	2.36	2.44	2.38	2.43	2.51	2.59	2.50	2.56	2.64	2.73	2.61	2.66	2.75	2.84	2.70	2.75	2.84	2.94
		Amps	7.8	8.0	8.3	8.6	8.5	8.7	9.0	9.3	9.2	9.4	9.8	10.1	9.9	10.1	10.4	10.8	10.5	10.8	11.1	11.6	11.1	11.4	11.8	12.3
	Hi PR	146	157	166	173	164	176	186	194	186	200	211	221	212	228	241	251	238	257	271	283	263	283	299	312	
	Lo PR	64	68	75	80	68	72	79	84	71	75	82	87	74	79	86	92	78	83	90	96	80	86	93	100	
	MBh	28.1	28.6	29.9	32.0	27.4	27.9	29.3	31.2	26.7	27.3	28.6	30.5	26.1	26.6	27.9	29.7	24.8	25.3	26.5	28.2	23.0	23.4	24.5	26.2	
	S/T	0.94	0.91	0.82	0.66	0.97	0.94	0.85	0.69	1.00	0.96	0.87	0.71	1.00	0.99	0.90	0.73	1.00	1.00	0.93	0.76	1.00	1.00	0.94	0.76	
	ΔT	23	23	21	19	23	23	22	19	23	23	22	19	23	23	22	19	22	22	22	19	20	20	20	17	
kW	2.07	2.12	2.18	2.25	2.23	2.28	2.35	2.42	2.37	2.42	2.49	2.58	2.49	2.54	2.62	2.71	2.59	2.65	2.73	2.82	2.68	2.74	2.83	2.92		
Amps	7.8	8.0	8.2	8.5	8.4	8.6	8.9	9.3	9.2	9.4	9.7	10.1	9.8	10.0	10.4	10.8	10.4	10.7	11.1	11.5	11.1	11.3	11.7	12.2		
Hi PR	145	156	165	172	162	175	185	193	185	199	210	219	210	226	239	249	237	255	269	281	262	281	297	310		
Lo PR	64	68	74	79	68	72	78	84	70	75	82	87	74	78	86	91	77	82	90	96	80	85	93	99		
MBh	26.7	27.2	28.5	30.4	26.0	26.5	27.8	29.6	25.4	25.9	27.1	28.9	24.8	25.3	26.5	28.2	23.6	24.0	25.1	26.8	21.8	22.2	23.3	24.8		
S/T	0.90	0.87	0.78	0.64	0.93	0.90	0.81	0.66	0.96	0.92	0.83	0.68	0.99	0.95	0.86	0.70	1.00	0.99	0.89	0.72	1.00	1.00	0.90	0.73		
ΔT	24	23	22	19	24	24	22	19	24	24	22	19	24	24	23	20	23	24	22	19	22	22	21	18		
kW	2.04	2.08	2.15	2.22	2.19	2.24	2.31	2.38	2.33	2.38	2.45	2.53	2.45	2.50	2.58	2.66	2.55	2.60	2.69	2.78	2.64	2.69	2.78	2.87		
Amps	7.6	7.8	8.1	8.4	8.3	8.5	8.8	9.1	9.0	9.2	9.5	9.9	9.6	9.9	10.2	10.6	10.2	10.5	10.8	11.3	10.9	11.1	11.5	11.9		
Hi PR	142	153	161	168	159	171	181	189	181	195	206	215	206	222	234	244	232	250	264	275	256	276	291	304		
Lo PR	63	67	73	77	66	70	77	82	69	73	80	85	72	77	84	89	76	81	88	94	78	83	91	97		

IDB: Entering Indoor Dry Bulb Temperature kW = Total system power Shaded area reflects ARI Rating conditions Amps = outdoor unit amps (comp. +fan)
 High and low pressures are measured at the liquid and suction service valves. Design Subcooling 9 ±3 °F @ the liquid service valve, ARI 95 test conditions

EXPANDED COOLING DATA — GSH130311A* / AWB36-XX / AWUF36XX1A*

IDB	Airflow	Outdoor Ambient Temperature																								
		65°F				75°F				85°F				95°F				105°F				115°F				
		59	63	67	71	59	63	67	71	59	63	67	71	59	63	67	71	59	63	67	71	59	63	67	71	
70	1173	MBh	26.5	27.4	30.0	-	25.8	26.8	29.3	-	25.2	26.1	28.6	-	24.6	25.5	28.0	-	23.4	24.2	26.6	-	21.7	22.4	24.6	-
		S/T	0.78	0.65	0.45	-	0.81	0.67	0.47	-	0.83	0.69	0.48	-	0.85	0.71	0.49	-	0.89	0.74	0.51	-	0.89	0.75	0.52	-
		ΔT	16	14	11	-	16	14	11	-	16	14	11	-	16	14	11	-	16	14	11	-	15	13	10	-
		kW	1.81	1.85	1.91	-	1.96	2.00	2.07	-	2.09	2.13	2.21	-	2.20	2.25	2.33	-	2.30	2.35	2.43	-	2.38	2.44	2.52	-
		Amps	8.0	8.1	8.4	-	8.6	8.8	9.0	-	9.3	9.5	9.8	-	9.9	10.1	10.4	-	10.5	10.7	11.0	-	11.0	11.3	11.7	-
	1050	Hi PR	147	159	168	-	165	178	188	-	188	202	214	-	214	231	244	-	241	259	274	-	266	287	303	-
		Lo PR	61	65	71	-	65	69	75	-	67	72	78	-	71	75	82	-	74	79	86	-	77	82	89	-
		MBh	26.1	27.0	29.6	-	25.5	26.4	28.9	-	24.9	25.8	28.2	-	24.2	25.1	27.5	-	23.0	23.9	26.2	-	21.3	22.1	24.2	-
		S/T	0.74	0.62	0.43	-	0.77	0.64	0.45	-	0.79	0.66	0.46	-	0.82	0.68	0.47	-	0.85	0.71	0.49	-	0.85	0.71	0.49	-
		ΔT	17	15	11	-	17	15	11	-	17	15	11	-	17	15	11	-	17	15	11	-	16	14	10	-
927	kW	1.80	1.84	1.90	-	1.95	1.99	2.06	-	2.07	2.12	2.19	-	2.19	2.24	2.31	-	2.28	2.34	2.42	-	2.37	2.42	2.51	-	
	Amps	7.9	8.1	8.3	-	8.5	8.7	9.0	-	9.2	9.4	9.7	-	9.8	10.0	10.3	-	10.4	10.6	11.0	-	11.0	11.2	11.6	-	
	Hi PR	146	158	166	-	164	177	187	-	187	201	212	-	213	229	242	-	239	258	272	-	265	285	301	-	
	Lo PR	61	65	71	-	64	69	75	-	67	71	78	-	70	75	82	-	74	78	86	-	76	81	89	-	
	MBh	24.8	25.7	28.1	-	24.2	25.1	27.5	-	23.6	24.5	26.8	-	23.0	23.9	26.2	-	21.9	22.7	24.9	-	20.3	21.0	23.0	-	

75	1173	MBh	26.9	27.7	30.0	32.2	26.3	27.1	29.3	31.4	25.7	26.4	28.6	30.7	25.0	25.8	27.9	29.9	23.8	24.5	26.5	28.4	22.0	22.7	24.5	26.3
		S/T	0.88	0.79	0.60	0.38	0.92	0.82	0.62	0.40	0.94	0.84	0.64	0.41	0.97	0.87	0.66	0.42	1.00	0.90	0.68	0.44	1.00	0.91	0.69	0.44
		ΔT	19	17	14	10	19	17	14	10	19	17	14	10	19	18	14	10	19	17	14	10	17	16	13	9
		kW	1.83	1.87	1.93	1.99	1.97	2.02	2.09	2.16	2.11	2.15	2.23	2.30	2.22	2.27	2.35	2.43	2.32	2.37	2.45	2.54	2.40	2.46	2.54	2.63
		Amps	8.0	8.2	8.5	8.8	8.6	8.8	9.1	9.4	9.3	9.6	9.8	10.2	9.9	10.2	10.5	10.9	10.5	10.8	11.1	11.5	11.1	11.4	11.8	12.2
	1050	Hi PR	149	160	169	177	167	180	190	198	190	205	216	225	216	233	246	257	244	262	277	289	269	290	306	319
		Lo PR	62	66	72	77	66	70	76	81	68	72	79	84	72	76	83	89	75	80	87	93	78	83	90	96
		MBh	26.5	27.3	29.5	31.7	25.9	26.7	28.9	31.0	25.3	26.0	28.2	30.2	24.7	25.4	27.5	29.5	23.4	24.1	26.1	28.0	21.7	22.3	24.2	26.0
		S/T	0.85	0.76	0.57	0.37	0.88	0.78	0.59	0.38	0.90	0.80	0.61	0.39	0.93	0.83	0.63	0.40	0.96	0.86	0.65	0.42	0.97	0.87	0.66	0.42
		ΔT	20	18	15	10	20	18	15	10	20	18	15	10	20	18.5	15	10	20	18	15	10	18	17	14	10
927	kW	1.82	1.86	1.92	1.98	1.96	2.01	2.07	2.15	2.09	2.14	2.21	2.29	2.21	2.26	2.34	2.42	2.30	2.36	2.44	2.52	2.39	2.44	2.53	2.62	
	Amps	8.0	8.2	8.4	8.7	8.6	8.8	9.1	9.4	9.3	9.5	9.8	10.1	9.9	10.1	10.4	10.8	10.5	10.7	11.1	11.5	11.1	11.3	11.7	12.1	
	Hi PR	148	159	168	175	166	179	189	197	189	203	215	224	215	231	244	255	242	260	275	287	267	288	304	317	
	Lo PR	62	66	72	76	65	69	76	81	68	72	79	84	71	76	83	88	74	79	86	92	77	82	89	95	
	MBh	25.2	25.9	28.1	30.1	24.6	25.3	27.4	29.4	24.0	24.7	26.8	28.7	23.4	24.1	26.1	28.0	22.3	22.9	24.8	26.6	20.6	21.2	23.0	24.7	

IDB: Entering Indoor Dry Bulb Temperature kW = Total system power Shaded area reflects ACCA (TVA) conditions Amps = outdoor unit amps (comp.+fan)
 High and low pressures are measured at the liquid and suction service valves. Design Subcooling 9 ±3 °F @ the liquid service valve, ARI 95 test conditions

EXPANDED COOLING DATA — GSH130311A* / AWB36-XX / AWUF36XX1A* (CONT.)

IDB	Airflow	Outdoor Ambient Temperature																									
		65°F				75°F				85°F				95°F				105°F				115°F					
		59	63	67	71	59	63	67	71	59	63	67	71	59	63	67	71	59	63	67	71	59	63	67	71		
80	1173	MBh	27.4	28.0	29.9	32.0	26.7	27.3	29.2	31.2	26.1	26.7	28.5	30.5	25.5	26.0	27.8	29.7	24.2	24.7	26.4	28.2	22.4	22.9	24.5	26.2	
		S/T	0.97	0.91	0.74	0.55	1.00	0.94	0.77	0.57	1.00	0.97	0.79	0.59	1.00	1.00	0.81	0.61	1.00	1.00	0.84	0.63	1.00	1.00	0.85	0.63	
	ΔT	21	20	17	14	21	20	18	14	20	20	18	14	20	20	18	14	19	19	17	14	18	18	16	13		
	kW	1.84	1.88	1.95	2.01	1.99	2.04	2.11	2.18	2.12	2.17	2.25	2.32	2.24	2.29	2.37	2.45	2.34	2.39	2.48	2.56	2.42	2.48	2.57	2.66		
	Amps	8.1	8.3	8.5	8.8	8.7	8.9	9.2	9.5	9.4	9.6	9.9	10.3	10.0	10.3	10.6	11.0	10.6	10.9	11.2	11.6	11.2	11.5	11.9	12.3		
	Hi PR	150	162	171	178	169	182	192	200	192	207	218	228	219	235	249	259	246	265	280	292	272	293	309	322		
	Lo PR	63	67	73	78	66	70	77	82	69	73	80	85	72	77	84	89	76	81	88	94	78	83	91	97		
	1050	MBh	27.0	27.6	29.5	31.5	26.4	26.9	28.8	30.8	25.7	26.3	28.1	30.0	25.1	25.6	27.4	29.3	23.8	24.4	26.0	27.8	22.1	22.6	24.1	25.8	
		S/T	0.93	0.87	0.71	0.53	0.96	0.90	0.73	0.55	0.99	0.92	0.75	0.56	1.00	0.95	0.78	0.58	1.00	0.99	0.81	0.60	1.00	1.00	0.81	0.61	
	927	1173	ΔT	22	21	18	15	22	21	18	15	22	21	19	15	22	21	19	15	21	21	18	15	19	20	17	14
kW			1.83	1.87	1.93	2.00	1.98	2.02	2.09	2.16	2.11	2.16	2.23	2.31	2.23	2.28	2.36	2.44	2.32	2.38	2.46	2.55	2.41	2.47	2.55	2.64	
Amps		8.1	8.2	8.5	8.8	8.7	8.9	9.1	9.5	9.4	9.6	9.9	10.2	10.0	10.2	10.5	10.9	10.6	10.8	11.2	11.6	11.2	11.4	11.8	12.2		
Hi PR		149	161	170	177	168	180	191	199	191	205	217	226	217	234	247	257	244	263	278	290	270	290	307	320		
Lo PR		62	66	72	77	66	70	76	81	68	73	79	85	72	76	83	89	75	80	87	93	78	83	90	96		
1050		MBh	25.6	26.2	28.0	29.9	25.0	25.6	27.3	29.2	24.4	25.0	26.7	28.5	23.8	24.4	26.0	27.8	22.7	23.1	24.7	26.4	21.0	21.4	22.9	24.5	
		S/T	0.89	0.83	0.68	0.51	0.92	0.86	0.70	0.53	0.94	0.89	0.72	0.54	0.98	0.91	0.74	0.56	1.01	0.95	0.77	0.58	1.02	0.96	0.78	0.58	
85		1173	ΔT	23	22	19	15	23	22	19	15	23	22	19	15	23	22	19	15	23	22	19	15	21	20	18	14
			kW	1.80	1.84	1.90	1.97	1.95	1.99	2.06	2.13	2.07	2.12	2.19	2.27	2.19	2.24	2.31	2.40	2.28	2.34	2.42	2.50	2.37	2.42	2.51	2.59
		Amps	7.9	8.1	8.3	8.6	8.5	8.7	9.0	9.3	9.2	9.4	9.7	10.0	9.8	10.0	10.3	10.7	10.4	10.6	11.0	11.4	11.0	11.2	11.6	12.0	
	Hi PR	146	158	166	174	164	177	187	195	187	201	212	221	213	229	242	252	239	258	272	284	265	285	301	314		
	Lo PR	61	65	71	75	64	69	75	80	67	71	78	83	70	75	82	87	74	78	86	91	76	81	89	94		
	1050	MBh	27.9	28.4	29.7	31.7	27.2	27.7	29.1	31.0	26.6	27.1	28.4	30.3	25.9	26.4	27.7	29.5	24.6	25.1	26.3	28.0	22.8	23.3	24.4	26.0	
		S/T	1.00	0.98	0.88	0.72	1.00	1.00	0.92	0.74	1.00	1.00	0.94	0.76	1.00	1.00	0.97	0.79	1.00	1.00	1.00	0.82	1.00	1.00	1.00	0.82	
	927	1173	ΔT	22	22	21	18	21	22	21	18	21	21	21	18	20	21	21	18	19	20	21	18	18	18	19	17
			kW	1.86	1.90	1.96	2.03	2.01	2.05	2.12	2.20	2.14	2.19	2.27	2.34	2.26	2.31	2.39	2.47	2.36	2.41	2.50	2.59	2.45	2.50	2.59	2.68
		Amps	8.2	8.4	8.6	8.9	8.8	9.0	9.3	9.6	9.5	9.7	10.0	10.4	10.1	10.3	10.7	11.1	10.7	11.0	11.3	11.7	11.3	11.6	12.0	12.4	
Hi PR		152	164	173	180	171	183	194	202	194	209	220	230	221	238	251	262	248	267	282	295	275	295	312	325		
Lo PR		63	67	74	78	67	71	78	83	70	74	81	86	73	78	85	90	77	81	89	95	79	84	92	98		
1050		MBh	27.5	28.0	29.3	31.3	26.8	27.3	28.6	30.5	26.2	26.7	27.9	29.8	25.5	26.0	27.3	29.1	24.3	24.7	25.9	27.6	22.5	22.9	24.0	25.6	
		S/T	0.97	0.94	0.85	0.69	1.00	0.97	0.88	0.71	1.00	1.00	0.90	0.73	1.00	1.00	0.93	0.75	1.00	1.00	1.00	0.78	1.00	1.00	0.97	0.79	
85		1173	ΔT	23	23	22	19	23	23	22	19	23	23	22	19	22	23	22	19	21	22	22	19	20	20	20	18
			kW	1.85	1.89	1.95	2.02	2.00	2.04	2.11	2.18	2.13	2.18	2.25	2.33	2.25	2.30	2.38	2.46	2.34	2.40	2.48	2.57	2.43	2.49	2.57	2.66
		Amps	8.1	8.3	8.6	8.9	8.7	8.9	9.2	9.5	9.4	9.7	10.0	10.3	10.1	10.3	10.6	11.0	10.7	10.9	11.3	11.7	11.3	11.5	11.9	12.3	
	Hi PR	151	162	171	179	169	182	192	201	193	207	219	228	219	236	249	260	247	266	280	292	273	293	310	323		
	Lo PR	63	67	73	78	66	71	77	82	69	73	80	85	72	77	84	90	76	81	88	94	79	84	91	97		
	1050	MBh	26.1	26.6	27.8	29.7	25.5	26.0	27.2	29.0	24.9	25.3	26.5	28.3	24.3	24.7	25.9	27.6	23.0	23.5	24.6	26.2	21.3	21.8	22.8	24.3	
		S/T	0.93	0.90	0.81	0.66	0.97	0.93	0.84	0.68	0.99	0.96	0.86	0.70	1.00	0.99	0.89	0.72	1.00	1.00	1.00	0.75	1.00	1.00	0.93	0.76	
	927	1173	ΔT	24	24	22	19	24	24	23	20	24	24	23	20	24	24	23	20	23	23	23	20	21	22	21	18
			kW	1.82	1.86	1.92	1.98	1.96	2.01	2.07	2.15	2.09	2.14	2.21	2.29	2.21	2.26	2.33	2.42	2.30	2.36	2.44	2.52	2.39	2.44	2.53	2.62
		Amps	8.0	8.2	8.4	8.7	8.6	8.8	9.1	9.4	9.3	9.5	9.8	10.1	9.9	10.1	10.4	10.8	10.5	10.7	11.1	11.5	11.1	11.3	11.7	12.1	
Hi PR		148	159	168	175	166	179	189	197	189	203	214	224	215	231	244	255	242	260	275	287	267	288	304	317		
Lo PR		62	66	72	76	65	69	76	80	68	72	79	84	71	76	83	88	74	79	86	91	77	82	89	95		

IDB: Entering Indoor Dry Bulb Temperature kW = Total system power Shaded area reflects ARI Rating conditions Amps = outdoor unit amps (comp.+fan)
 High and low pressures are measured at the liquid and suction service valves. Design Subcooling 9 ±3 °F @ the liquid service valve, ARI 95 test conditions

EXPANDED COOLING DATA — GSH130361** / ARUF49-00*-1* / ARUF36421A*

IDB	Airflow	Outdoor Ambient Temperature																								
		65°F				75°F				85°F				95°F				105°F				115°F				
		59	63	67	71	59	63	67	71	59	63	67	71	59	63	67	71	59	63	67	71	59	63	67	71	
70	1425	MBh	33.8	35.0	38.4	-	33.0	34.2	37.5	-	32.2	33.4	36.6	-	31.4	32.6	35.7	-	29.9	31.0	33.9	-	27.7	28.7	31.4	-
		S/T	0.76	0.63	0.44	-	0.79	0.66	0.45	-	0.80	0.67	0.47	-	0.83	0.69	0.48	-	0.86	0.72	0.50	-	0.87	0.73	0.50	-
		ΔT	17	14	11	-	17	14	11	-	17	14	11	-	17	15	11	-	17	14	11	-	16	13	10	-
		kW	2.47	2.52	2.60	-	2.65	2.70	2.79	-	2.81	2.86	2.95	-	2.95	3.01	3.10	-	3.06	3.13	3.23	-	3.16	3.23	3.33	-
		Amps	9.2	9.4	9.7	-	9.9	10.1	10.5	-	10.7	11.0	11.3	-	11.5	11.7	12.1	-	12.2	12.5	12.9	-	12.9	13.2	13.6	-
		Hi PR	143	154	163	-	161	173	183	-	183	197	208	-	208	224	236	-	234	252	266	-	259	278	294	-
	Lo PR	65	69	76	-	69	73	80	-	72	76	83	-	75	80	87	-	79	84	91	-	81	87	95	-	
	1275	MBh	33.3	34.5	37.8	-	32.5	33.7	36.9	-	31.7	32.9	36.1	-	31.0	32.1	35.2	-	29.4	30.5	33.4	-	27.3	28.3	31.0	-
		S/T	0.73	0.61	0.42	-	0.75	0.63	0.43	-	0.77	0.64	0.45	-	0.80	0.66	0.46	-	0.83	0.69	0.48	-	0.83	0.70	0.48	-
		ΔT	17	15	11	-	18	15	12	-	18	15	12	-	18	15	12	-	18	15	12	-	16	14	11	-
		kW	2.46	2.51	2.58	-	2.64	2.69	2.77	-	2.79	2.85	2.94	-	2.93	2.99	3.08	-	3.05	3.11	3.21	-	3.15	3.21	3.32	-
		Amps	9.1	9.3	9.6	-	9.8	10.1	10.4	-	10.7	10.9	11.3	-	11.4	11.7	12.0	-	12.1	12.4	12.8	-	12.8	13.1	13.6	-
Hi PR		142	153	162	-	159	172	181	-	181	195	206	-	207	222	235	-	232	250	264	-	257	276	292	-	
Lo PR	65	69	75	-	68	73	79	-	71	76	82	-	75	79	87	-	78	83	91	-	81	86	94	-		
1125	MBh	31.6	32.8	35.9	-	30.9	32.0	35.1	-	30.2	31.3	34.3	-	29.4	30.5	33.4	-	28.0	29.0	31.7	-	25.9	26.8	29.4	-	
	S/T	0.69	0.58	0.40	-	0.72	0.60	0.42	-	0.74	0.62	0.43	-	0.76	0.64	0.44	-	0.79	0.66	0.46	-	0.80	0.67	0.46	-	
	ΔT	18	16	12	-	18	16	12	-	18	16	12	-	18	16	12	-	18	16	12	-	17	15	11	-	
	kW	2.42	2.47	2.54	-	2.60	2.65	2.73	-	2.75	2.81	2.89	-	2.88	2.94	3.03	-	3.00	3.06	3.16	-	3.10	3.16	3.26	-	
	Amps	9.0	9.2	9.5	-	9.7	9.9	10.2	-	10.5	10.7	11.1	-	11.2	11.4	11.8	-	11.9	12.2	12.6	-	12.6	12.9	13.3	-	
	Hi PR	139	150	158	-	156	168	178	-	178	191	202	-	202	218	230	-	228	245	259	-	252	271	286	-	
Lo PR	63	67	74	-	67	71	78	-	70	74	81	-	73	78	85	-	77	82	89	-	79	84	92	-		
75	1425	MBh	34.4	35.4	38.3	41.1	33.6	34.6	37.4	40.2	32.8	33.7	36.5	39.2	32.0	32.9	35.6	38.2	30.4	31.3	33.8	36.3	28.1	29.0	31.4	33.7
		S/T	0.86	0.77	0.58	0.37	0.89	0.80	0.60	0.39	0.91	0.82	0.62	0.40	0.94	0.84	0.64	0.41	0.98	0.88	0.66	0.43	0.99	0.88	0.67	0.43
		ΔT	19	18	14	10	19	18	15	10	19	18	15	10	19	18	15	10	19	18	14	10	18	17	14	9
		kW	2.49	2.54	2.62	2.69	2.67	2.72	2.81	2.89	2.83	2.89	2.98	3.07	2.97	3.03	3.13	3.23	3.09	3.15	3.25	3.36	3.19	3.26	3.36	3.47
		Amps	9.3	9.5	9.8	10.1	10.0	10.2	10.5	10.9	10.8	11.1	11.4	11.9	11.6	11.8	12.2	12.7	12.3	12.6	13.0	13.5	13.0	13.3	13.8	14.3
		Hi PR	145	156	164	171	162	175	184	192	185	199	210	219	210	226	239	249	236	254	269	280	261	281	297	310
	Lo PR	66	70	76	81	70	74	81	86	72	77	84	89	76	81	88	94	80	85	92	98	82	88	96	102	
	1275	MBh	33.9	34.9	37.7	40.5	33.1	34.1	36.9	39.6	32.3	33.2	36.0	38.6	31.5	32.4	35.1	37.7	29.9	30.8	33.3	35.8	27.7	28.5	30.9	33.2
		S/T	0.82	0.74	0.56	0.36	0.85	0.76	0.58	0.37	0.88	0.78	0.59	0.38	0.90	0.81	0.61	0.39	0.94	0.84	0.64	0.41	0.95	0.85	0.64	0.41
		ΔT	20	19	15	10	20	19	15	11	20	19	15	11	21	19	15	11	20	19	15	11	19	17	14	10
		kW	2.48	2.53	2.60	2.68	2.66	2.71	2.79	2.88	2.81	2.87	2.96	3.05	2.95	3.01	3.11	3.21	3.07	3.14	3.23	3.34	3.17	3.24	3.34	3.45
		Amps	9.2	9.4	9.7	10.1	9.9	10.2	10.5	10.9	10.8	11.0	11.4	11.8	11.5	11.8	12.1	12.6	12.2	12.5	12.9	13.4	12.9	13.2	13.7	14.2
Hi PR		144	155	163	170	161	173	183	191	183	197	208	217	209	225	237	247	235	253	267	278	259	279	295	307	
Lo PR	65	70	76	81	69	73	80	85	72	76	83	89	75	80	88	93	79	84	92	98	82	87	95	101		
1125	MBh	32.2	33.1	35.9	38.5	31.4	32.4	35.0	37.6	30.7	31.6	34.2	36.7	29.9	30.8	33.3	35.8	28.4	29.3	31.7	34.0	26.3	27.1	29.3	31.5	
	S/T	0.79	0.71	0.53	0.34	0.82	0.73	0.55	0.36	0.84	0.75	0.57	0.37	0.87	0.77	0.59	0.38	0.90	0.80	0.61	0.39	0.91	0.81	0.61	0.39	
	ΔT	21	19	16	11	21	19	16	11	21	19	16	11	21	20	16	11	21	19	16	11	20	18	15	10	
	kW	2.44	2.49	2.56	2.64	2.62	2.67	2.75	2.83	2.77	2.83	2.91	3.00	2.91	2.97	3.06	3.16	3.02	3.09	3.18	3.28	3.12	3.19	3.29	3.39	
	Amps	9.0	9.2	9.5	9.9	9.7	10.0	10.3	10.7	10.6	10.8	11.2	11.6	11.3	11.5	11.9	12.4	12.0	12.3	12.7	13.2	12.7	13.0	13.4	13.9	
	Hi PR	141	151	160	167	158	170	179	187	180	193	204	213	205	220	232	242	230	248	261	273	254	274	289	301	
Lo PR	64	68	74	79	68	72	79	84	70	75	82	87	74	79	86	91	77	82	90	96	80	85	93	99		

IDB: Entering Indoor Dry Bulb Temperature kW = Total system power Shaded area reflects ACCA (TVA) conditions Amps = outdoor unit amps (comp.+fan)
 High and low pressures are measured at the liquid and suction service valves. Design Subcooling 9 ±3 °F @ the liquid service valve, ARI 95 test conditions

EXPANDED COOLING DATA — GSH130361** / ARUF49-00*-1* / ARUF36421A* (CONT.)

IDB	Airflow	Outdoor Ambient Temperature																								
		65°F				75°F				85°F				95°F				105°F				115°F				
		59	63	67	71	59	63	67	71	59	63	67	71	59	63	67	71	59	63	67	71	59	63	67	71	
80	1425	MBh	35.0	35.7	38.2	40.8	34.2	34.9	37.3	39.9	33.4	34.1	36.4	38.9	32.5	33.3	35.5	38.0	30.9	31.6	33.7	36.1	28.6	29.3	31.3	33.4
		S/T	0.94	0.89	0.72	0.54	0.98	0.92	0.75	0.56	1.00	0.94	0.77	0.57	1.00	0.97	0.79	0.59	1.00	1.00	0.82	0.61	1.00	1.00	0.83	0.62
	ΔT	21	20	18	14	22	21	18	14	22	21	18	14	21	21	18	14	20	20	18	14	18	19	17	13	
	kW	2.51	2.56	2.64	2.72	2.69	2.75	2.83	2.92	2.85	2.91	3.00	3.09	2.99	3.06	3.15	3.25	3.11	3.18	3.28	3.38	3.22	3.28	3.39	3.50	
	Amps	9.3	9.6	9.9	10.2	10.1	10.3	10.6	11.0	10.9	11.2	11.6	12.0	11.7	11.9	12.3	12.8	12.4	12.7	13.1	13.6	13.1	13.4	13.9	14.4	
	Hi PR	146	157	166	173	164	176	186	194	186	201	212	221	212	228	241	252	239	257	271	283	264	284	300	313	
	Lo PR	66	71	77	82	70	75	82	87	73	78	85	90	77	82	89	95	80	85	93	99	83	88	97	103	
	MBh	34.5	35.2	37.6	40.2	33.7	34.4	36.8	39.3	32.9	33.6	35.9	38.4	32.1	32.8	35.0	37.4	30.5	31.1	33.3	35.5	28.2	28.8	30.8	32.9	
	S/T	0.90	0.85	0.69	0.52	0.94	0.88	0.72	0.53	0.96	0.90	0.73	0.55	0.99	0.93	0.76	0.57	1.00	0.97	0.79	0.59	1.00	0.97	0.79	0.59	
	ΔT	22	22	19	15	23	22	19	15	23	22	19	15	23	22	19	15	22	22	19	15	20	20	18	14	
kW	2.50	2.55	2.62	2.70	2.68	2.73	2.81	2.90	2.84	2.89	2.98	3.08	2.98	3.04	3.13	3.23	3.10	3.16	3.26	3.37	3.20	3.27	3.37	3.48		
Amps	9.3	9.5	9.8	10.2	10.0	10.2	10.6	11.0	10.9	11.1	11.5	11.9	11.6	11.9	12.3	12.7	12.3	12.6	13.0	13.5	13.0	13.4	13.8	14.3		
Hi PR	145	156	165	172	163	175	185	193	185	199	210	219	211	227	240	250	237	255	270	281	262	282	298	311		
Lo PR	66	70	77	82	70	74	81	86	72	77	84	90	76	81	88	94	80	85	93	99	83	88	96	102		
MBh	32.7	33.5	35.7	38.2	32.0	32.7	34.9	37.3	31.2	31.9	34.1	36.4	30.5	31.1	33.3	35.5	28.9	29.6	31.6	33.8	26.8	27.4	29.3	31.3		
S/T	0.87	0.81	0.66	0.49	0.90	0.84	0.69	0.51	0.92	0.86	0.70	0.53	0.95	0.89	0.73	0.54	0.99	0.92	0.75	0.56	0.99	0.93	0.76	0.57		
ΔT	23	22	19	15	23	22	20	16	23	23	20	16	24	23	20	16	23	22	19	16	22	21	18	14		
kW	2.46	2.51	2.58	2.66	2.64	2.69	2.77	2.86	2.79	2.85	2.94	3.03	2.93	2.99	3.08	3.18	3.05	3.11	3.21	3.31	3.15	3.21	3.32	3.42		
Amps	9.1	9.3	9.6	10.0	9.8	10.1	10.4	10.8	10.7	10.9	11.3	11.7	11.4	11.7	12.0	12.5	12.1	12.4	12.8	13.3	12.8	13.1	13.6	14.1		
Hi PR	142	153	162	168	159	172	181	189	181	195	206	215	207	222	235	245	232	250	264	275	257	276	292	304		
Lo PR	65	69	75	80	68	73	79	85	71	76	82	88	75	79	87	92	78	83	91	97	81	86	94	100		

85	1425	MBh	35.6	36.3	38.0	40.5	34.8	35.4	37.1	39.6	33.9	34.6	36.2	38.7	33.1	33.8	35.3	37.7	31.5	32.1	33.6	35.8	29.1	29.7	31.1	33.2
		S/T	0.99	0.96	0.86	0.70	1.00	0.99	0.89	0.72	1.00	1.00	0.92	0.74	1.00	1.00	0.95	0.77	1.00	1.00	0.98	0.80	1.00	1.00	0.99	0.80
	ΔT	23	22	21	18	22	23	21	19	22	22	21	19	21	22	22	19	20	21	21	18	19	19	20	17	
	kW	2.53	2.58	2.66	2.74	2.71	2.77	2.85	2.94	2.87	2.93	3.02	3.12	3.02	3.08	3.18	3.28	3.14	3.20	3.31	3.41	3.24	3.31	3.42	3.53	
	Amps	9.4	9.6	9.9	10.3	10.2	10.4	10.7	11.1	11.0	11.3	11.7	12.1	11.8	12.1	12.4	12.9	12.5	12.8	13.2	13.7	13.2	13.6	14.0	14.5	
	Hi PR	148	159	168	175	166	178	188	196	188	203	214	223	214	231	244	254	241	260	274	286	267	287	303	316	
	Lo PR	67	71	78	83	71	75	82	88	74	78	86	91	77	82	90	96	81	86	94	100	84	89	97	104	
	MBh	35.1	35.7	37.4	39.9	34.3	34.9	36.6	39.0	33.4	34.1	35.7	38.1	32.6	33.3	34.8	37.2	31.0	31.6	33.1	35.3	28.7	29.3	30.6	32.7	
	S/T	0.95	0.91	0.83	0.67	0.98	0.95	0.86	0.69	1.00	0.97	0.88	0.71	1.00	1.00	0.91	0.73	1.00	1.00	0.94	0.76	1.00	1.00	0.95	0.77	
	ΔT	24	24	22	19	24	24	23	20	24	24	23	20	24	24	23	20	22	23	22	19	21	21	21	18	
kW	2.52	2.57	2.64	2.72	2.70	2.75	2.84	2.92	2.86	2.92	3.01	3.10	3.00	3.06	3.16	3.26	3.12	3.19	3.29	3.39	3.22	3.29	3.40	3.51		
Amps	9.4	9.6	9.9	10.2	10.1	10.3	10.7	11.1	11.0	11.2	11.6	12.0	11.7	12.0	12.4	12.8	12.4	12.7	13.2	13.6	13.2	13.5	13.9	14.5		
Hi PR	146	158	166	174	164	177	187	195	187	201	212	222	213	229	242	252	240	258	272	284	265	285	301	314		
Lo PR	67	71	77	82	70	75	82	87	73	78	85	91	77	82	89	95	81	86	94	100	83	89	97	103		
MBh	33.3	34.0	35.6	37.9	32.5	33.2	34.7	37.1	31.8	32.4	33.9	36.2	31.0	31.6	33.1	35.3	29.4	30.0	31.4	33.5	27.3	27.8	29.1	31.1		
S/T	0.91	0.88	0.79	0.64	0.94	0.91	0.82	0.66	0.96	0.93	0.84	0.68	1.00	0.96	0.87	0.70	1.00	1.00	0.90	0.73	1.00	1.00	0.91	0.74		
ΔT	25	24	23	20	25	25	23	20	25	25	23	20	25	25	23	20	24	24	23	20	22	22	23	19		
kW	2.48	2.53	2.60	2.68	2.66	2.71	2.79	2.88	2.81	2.87	2.96	3.05	2.95	3.01	3.11	3.21	3.07	3.14	3.23	3.34	3.17	3.24	3.34	3.45		
Amps	9.2	9.4	9.7	10.1	9.9	10.2	10.5	10.9	10.8	11.0	11.4	11.8	11.5	11.8	12.1	12.6	12.2	12.5	12.9	13.4	12.9	13.2	13.7	14.2		
Hi PR	144	154	163	170	161	173	183	191	183	197	208	217	209	225	237	247	235	253	267	278	259	279	295	307		
Lo PR	65	69	76	81	69	73	80	85	72	76	83	89	75	80	88	93	79	84	92	98	82	87	95	101		

IDB: Entering Indoor Dry Bulb Temperature kW = Total system power Shaded area reflects ARI Rating conditions Amps = outdoor unit amps (comp.+fan)
 High and low pressures are measured at the liquid and suction service valves. Design Subcooling 9 ±3 °F @ the liquid service valve, ARI 95 test conditions

EXPANDED COOLING DATA — GSH130363A* / ARUF49-00*-1* / ARUF36421A*

IDB	Airflow	Outdoor Ambient Temperature																								
		65°F				75°F				85°F				95°F				105°F				115°F				
		59	63	67	71	59	63	67	71	59	63	67	71	59	63	67	71	59	63	67	71	59	63	67	71	
70	1434	MBh	34.3	35.5	38.9	-	33.5	34.7	38.0	-	32.7	33.9	37.1	-	31.9	33.1	36.2	-	30.3	31.4	34.4	-	28.1	29.1	31.9	-
		S/T	0.76	0.64	0.44	-	0.79	0.66	0.46	-	0.81	0.67	0.47	-	0.83	0.70	0.48	-	0.87	0.72	0.50	-	0.87	0.73	0.51	-
		ΔT	17	14	11	-	17	15	11	-	17	15	11	-	17	15	11	-	17	15	11	-	16	14	10	-
		kW	2.38	2.43	2.50	-	2.56	2.61	2.69	-	2.71	2.77	2.86	-	2.85	2.91	3.00	-	2.96	3.03	3.12	-	3.06	3.13	3.23	-
		Amps	7.7	7.8	8.1	-	8.2	8.4	8.7	-	8.9	9.1	9.4	-	9.5	9.7	10.0	-	10.1	10.3	10.7	-	10.7	10.9	11.3	-
		Hi/PR	140	151	160	-	158	170	179	-	179	193	204	-	204	220	232	-	230	247	261	-	254	273	288	-
	Lo/PR	63	67	73	-	67	71	77	-	69	74	81	-	73	77	85	-	76	81	89	-	79	84	92	-	
	1275	MBh	33.3	34.5	37.8	-	32.5	33.7	36.9	-	31.7	32.9	36.1	-	31.0	32.1	35.2	-	29.4	30.5	33.4	-	27.3	28.3	31.0	-
		S/T	0.73	0.61	0.42	-	0.75	0.63	0.43	-	0.77	0.64	0.45	-	0.80	0.66	0.46	-	0.83	0.69	0.48	-	0.83	0.70	0.48	-
		ΔT	17	15	11	-	18	15	12	-	18	15	12	-	18	15	12	-	18	15	12	-	16	14	11	-
		kW	2.36	2.41	2.49	-	2.54	2.59	2.67	-	2.69	2.75	2.83	-	2.83	2.89	2.98	-	2.94	3.00	3.10	-	3.04	3.11	3.21	-
		Amps	7.6	7.8	8.0	-	8.2	8.4	8.6	-	8.8	9.0	9.3	-	9.4	9.6	9.9	-	10.0	10.2	10.6	-	10.6	10.8	11.2	-
Hi/PR		139	150	158	-	156	168	177	-	177	191	202	-	202	217	230	-	227	245	258	-	251	270	285	-	
Lo/PR	63	66	73	-	66	70	77	-	69	73	80	-	72	77	84	-	76	80	88	-	78	83	91	-		
1116	MBh	30.7	31.9	34.9	-	30.0	31.1	34.1	-	29.3	30.4	33.3	-	28.6	29.6	32.5	-	27.2	28.2	30.8	-	25.2	26.1	28.6	-	
	S/T	0.70	0.58	0.40	-	0.72	0.61	0.42	-	0.74	0.62	0.43	-	0.77	0.64	0.44	-	0.80	0.66	0.46	-	0.80	0.67	0.46	-	
	ΔT	18	15	12	-	18	16	12	-	18	16	12	-	18	16	12	-	18	15	12	-	17	14	11	-	
	kW	2.31	2.36	2.43	-	2.48	2.53	2.61	-	2.63	2.68	2.77	-	2.76	2.82	2.91	-	2.87	2.93	3.02	-	2.97	3.03	3.13	-	
	Amps	7.4	7.6	7.8	-	8.0	8.1	8.4	-	8.6	8.8	9.1	-	9.2	9.4	9.7	-	9.7	10.0	10.3	-	10.3	10.5	10.9	-	
	Hi/PR	135	145	153	-	151	163	172	-	172	185	196	-	196	211	223	-	220	237	251	-	244	262	277	-	
Lo/PR	61	65	70	-	64	68	74	-	67	71	77	-	70	74	81	-	73	78	85	-	76	81	88	-		
75	1434	MBh	34.9	35.9	38.9	41.7	34.1	35.1	38.0	40.7	33.3	34.2	37.1	39.8	32.4	33.4	36.2	38.8	30.8	31.7	34.4	36.9	28.6	29.4	31.8	34.2
		S/T	0.86	0.77	0.59	0.38	0.90	0.80	0.61	0.39	0.92	0.82	0.62	0.40	0.95	0.85	0.64	0.41	0.98	0.88	0.67	0.43	0.99	0.89	0.67	0.43
		ΔT	19	18	15	10	20	18	15	10	20	18	15	10	20	18	15	10	19	18	15	10	18	17	14	9
		kW	2.40	2.45	2.52	2.60	2.58	2.63	2.71	2.80	2.73	2.79	2.88	2.97	2.87	2.93	3.03	3.12	2.99	3.05	3.15	3.25	3.09	3.16	3.26	3.37
		Amps	7.7	7.9	8.1	8.4	8.3	8.5	8.8	9.1	9.0	9.2	9.5	9.8	9.6	9.8	10.1	10.5	10.2	10.4	10.8	11.2	10.8	11.0	11.4	11.8
		Hi/PR	142	153	161	168	159	171	181	189	181	195	206	214	206	222	234	244	232	250	263	275	256	276	291	304
	Lo/PR	64	68	74	79	67	72	78	83	70	74	81	87	74	78	85	91	77	82	90	95	80	85	93	99	
	1275	MBh	33.9	34.9	37.7	40.5	33.1	34.1	36.9	39.6	32.3	33.2	36.0	38.6	31.5	32.4	35.1	37.7	29.9	30.8	33.3	35.8	27.7	28.5	30.9	33.2
		S/T	0.82	0.74	0.56	0.36	0.85	0.76	0.58	0.37	0.88	0.78	0.59	0.38	0.90	0.81	0.61	0.39	0.94	0.84	0.64	0.41	0.95	0.85	0.64	0.41
		ΔT	20	19	15	10	20	19	15	11	20	19	15	11	21	19	15	11	20	19	15	11	19	17	14	10
		kW	2.38	2.43	2.50	2.58	2.56	2.61	2.69	2.78	2.71	2.77	2.86	2.95	2.85	2.91	3.00	3.10	2.96	3.03	3.13	3.23	3.06	3.13	3.23	3.34
		Amps	7.7	7.8	8.1	8.4	8.2	8.4	8.7	9.0	8.9	9.1	9.4	9.8	9.5	9.7	10.0	10.4	10.1	10.3	10.7	11.1	10.7	10.9	11.3	11.7
Hi/PR		140	151	160	166	158	170	179	187	179	193	204	212	204	220	232	242	230	247	261	272	254	273	288	301	
Lo/PR	63	67	73	78	67	71	77	83	69	74	81	86	73	77	85	90	76	81	89	94	79	84	92	98		
1116	MBh	31.3	32.2	34.8	37.4	30.5	31.4	34.0	36.5	29.8	30.7	33.2	35.6	29.1	29.9	32.4	34.8	27.6	28.4	30.8	33.0	25.6	26.3	28.5	30.6	
	S/T	0.79	0.71	0.54	0.35	0.82	0.74	0.56	0.36	0.84	0.76	0.57	0.37	0.87	0.78	0.59	0.38	0.91	0.81	0.61	0.39	0.91	0.82	0.62	0.40	
	ΔT	20	19	15	11	21	19	16	11	21	19	16	11	21	19	16	11	21	19	16	11	19	18	15	10	
	kW	2.33	2.38	2.45	2.52	2.50	2.55	2.63	2.71	2.65	2.70	2.79	2.88	2.78	2.84	2.93	3.02	2.89	2.95	3.05	3.15	2.99	3.05	3.15	3.26	
	Amps	7.5	7.6	7.9	8.1	8.0	8.2	8.5	8.8	8.7	8.9	9.2	9.5	9.3	9.5	9.8	10.1	9.8	10.1	10.4	10.8	10.4	10.6	11.0	11.4	
	Hi/PR	136	147	155	161	153	164	174	181	174	187	197	206	198	213	225	235	223	240	253	264	246	265	280	292	
Lo/PR	61	65	71	76	65	69	75	80	67	72	78	83	71	75	82	87	74	79	86	92	77	81	89	95		

IDB: Entering Indoor Dry Bulb Temperature kW = Total system power Shaded area reflects ACCA (TVA) conditions Amps = outdoor unit amps (comp.+fan)
 High and low pressures are measured at the liquid and suction service valves. Design Subcooling 9 ±3 °F @ the liquid service valve, ARI 95 test conditions

EXPANDED COOLING DATA — GSH130421A* / ARUF49-00*-1* / ARUF36421A*

IDB	Airflow	Outdoor Ambient Temperature																								
		65°F					75°F					85°F														
		59	63	67	71	75	59	63	67	71	75	59	63	67	71	75										
		Entering Indoor Wet Bulb Temperature																								
		59	63	67	71	75	59	63	67	71	75	59	63	67	71	75	59	63	67	71	75					
70	1688	39.2	40.6	44.5	-	38.3	39.7	43.5	-	37.4	38.7	42.4	-	36.5	37.8	41.4	-	34.6	35.9	39.3	-	32.1	33.3	36.4	-	
		S/T	0.77	0.64	0.44	-	0.79	0.66	0.46	-	0.81	0.68	0.47	-	0.84	0.70	0.49	-	0.87	0.73	0.50	-	0.88	0.73	0.51	-
		ΔT	16	14	11	-	17	14	11	-	17	14	11	-	17	14	11	-	16	14	11	-	15	13	10	-
		kW	2.84	2.90	2.98	-	3.05	3.11	3.20	-	3.22	3.29	3.39	-	3.38	3.45	3.56	-	3.51	3.59	3.70	-	3.63	3.70	3.82	-
		Amps	10.6	10.8	11.2	-	11.4	11.7	12.1	-	12.4	12.7	13.1	-	13.2	13.6	14.0	-	14.1	14.4	14.9	-	14.9	15.3	15.8	-
75	1500	Hi PR	137	148	156	-	154	166	175	-	175	188	199	-	199	215	227	-	224	241	255	-	248	267	282	-
		Lo PR	60	64	70	-	64	68	74	-	66	70	77	-	70	74	81	-	73	78	85	-	75	80	88	-
		MBh	38.1	39.4	43.2	-	37.2	38.5	42.2	-	36.3	37.6	41.2	-	35.4	36.7	40.2	-	33.6	34.9	38.2	-	31.2	32.3	35.4	-
		S/T	0.73	0.61	0.42	-	0.76	0.63	0.44	-	0.78	0.65	0.45	-	0.80	0.67	0.46	-	0.83	0.69	0.48	-	0.84	0.70	0.49	-
		ΔT	17	15	11	-	17	15	11	-	17	15	11	-	17	15	11	-	17	15	11	-	16	14	11	-
1313	1500	kW	2.82	2.88	2.96	-	3.02	3.08	3.17	-	3.20	3.26	3.36	-	3.35	3.42	3.53	-	3.49	3.56	3.67	-	3.60	3.68	3.79	-
		Amps	10.5	10.7	11.1	-	11.3	11.6	11.9	-	12.3	12.6	13.0	-	13.1	13.4	13.9	-	13.9	14.3	14.8	-	14.8	15.1	15.6	-
		Hi PR	136	146	154	-	152	164	173	-	173	187	197	-	197	212	224	-	222	239	252	-	245	264	279	-
		Lo PR	60	63	69	-	63	67	73	-	66	70	76	-	69	73	80	-	72	77	84	-	75	79	87	-
		MBh	35.1	36.4	39.9	-	34.3	35.6	39.0	-	33.5	34.7	38.0	-	32.7	33.9	37.1	-	31.0	32.2	35.2	-	28.8	29.8	32.7	-
1688	1500	S/T	0.70	0.59	0.41	-	0.73	0.61	0.42	-	0.75	0.63	0.43	-	0.77	0.65	0.45	-	0.80	0.67	0.46	-	0.81	0.68	0.47	-
		ΔT	17	15	11	-	18	15	12	-	18	15	12	-	18	15	12	-	17	15	11	-	16	14	11	-
		kW	2.76	2.82	2.90	-	2.96	3.01	3.10	-	3.13	3.19	3.28	-	3.28	3.34	3.45	-	3.40	3.47	3.58	-	3.51	3.59	3.70	-
		Amps	10.2	10.4	10.8	-	11.0	11.3	11.6	-	11.9	12.2	12.6	-	12.7	13.1	13.5	-	13.6	13.9	14.4	-	14.4	14.7	15.2	-
		Hi PR	132	142	150	-	148	159	168	-	168	181	191	-	191	206	218	-	215	232	245	-	238	256	270	-
1500	1688	Lo PR	58	62	67	-	61	65	71	-	64	68	74	-	67	71	78	-	70	74	81	-	72	77	84	-
		MBh	39.9	41.0	44.4	47.7	38.9	40.1	43.4	46.6	38.0	39.1	42.4	45.5	37.1	38.2	41.3	44.4	35.2	36.3	39.3	42.1	32.6	33.6	36.4	39.0
		S/T	0.87	0.78	0.59	0.38	0.90	0.81	0.61	0.39	0.93	0.83	0.63	0.40	0.95	0.85	0.65	0.42	0.99	0.89	0.67	0.43	1.00	0.89	0.68	0.44
		ΔT	19	17	14	10	19	18	14	10	19	18	14	10	19	18	15	10	19	18	14	10	18	16	13	9
		kW	2.87	2.92	3.01	3.10	3.07	3.13	3.22	3.32	3.25	3.31	3.41	3.52	3.41	3.48	3.58	3.70	3.54	3.62	3.73	3.85	3.66	3.73	3.85	3.97
1313	1500	Amps	10.7	10.9	11.3	11.7	11.5	11.8	12.2	12.6	12.5	12.8	13.2	13.7	13.4	13.7	14.1	14.7	14.2	14.6	15.0	15.6	15.1	15.4	15.9	16.5
		Hi PR	139	149	157	164	155	167	177	184	177	190	201	210	201	217	229	239	227	244	257	269	250	269	285	297
		Lo PR	61	65	71	75	64	68	75	80	67	71	78	83	70	75	82	87	74	78	85	91	76	81	88	94
		MBh	38.7	39.8	43.1	46.3	37.8	38.9	42.1	45.2	36.9	38.0	41.1	44.1	36.0	37.1	40.1	43.1	34.2	35.2	38.1	40.9	31.7	32.6	35.3	37.9
		S/T	0.83	0.74	0.56	0.36	0.86	0.77	0.58	0.37	0.88	0.79	0.60	0.38	0.91	0.81	0.62	0.40	0.95	0.85	0.64	0.41	0.95	0.85	0.65	0.42
1688	1500	ΔT	20	18	15	10	20	18	15	10	20	18	15	10	20	19	15	10	20	18	15	10	19	17	14	10
		kW	2.84	2.90	2.98	3.07	3.05	3.11	3.20	3.30	3.22	3.29	3.39	3.49	3.38	3.45	3.56	3.67	3.51	3.59	3.70	3.82	3.63	3.70	3.82	3.94
		Amps	10.6	10.8	11.2	11.6	11.4	11.7	12.1	12.5	12.4	12.7	13.1	13.6	13.2	13.6	14.0	14.5	14.1	14.4	14.9	15.5	14.9	15.3	15.8	16.4
		Hi PR	137	148	156	163	154	166	175	182	175	188	199	208	199	215	227	236	224	241	255	266	248	267	282	294
		Lo PR	60	64	70	75	64	68	74	79	66	70	77	82	70	74	81	86	73	78	85	90	75	80	88	93
1313	1500	MBh	35.7	36.8	39.8	42.7	34.9	35.9	38.9	41.7	34.1	35.1	38.0	40.7	33.2	34.2	37.0	39.7	31.6	32.5	35.2	37.8	29.2	30.1	32.6	35.0
		S/T	0.80	0.72	0.54	0.35	0.83	0.74	0.56	0.36	0.85	0.76	0.58	0.37	0.88	0.79	0.59	0.38	0.91	0.82	0.62	0.40	0.92	0.82	0.62	0.40
		ΔT	20	18	15	10	20	19	15	11	20	19	15	11	20	19	15	11	20	19	15	11	19	17	14	10
		kW	2.78	2.84	2.92	3.00	2.98	3.04	3.13	3.22	3.15	3.21	3.31	3.41	3.30	3.37	3.47	3.58	3.43	3.50	3.61	3.72	3.54	3.62	3.73	3.85
		Amps	10.3	10.5	10.9	11.3	11.1	11.4	11.7	12.2	12.0	12.3	12.7	13.2	12.9	13.2	13.6	14.1	13.7	14.0	14.5	15.0	14.5	14.9	15.4	15.9
1688	1500	Hi PR	133	143	151	158	149	161	170	177	170	183	193	201	193	208	220	229	218	234	247	258	240	259	273	285
		Lo PR	58	62	68	72	62	66	72	76	64	68	75	79	67	72	78	83	71	75	82	87	73	78	85	90

IDB: Entering Indoor Dry Bulb Temperature kW = Total system power Shaded area reflects ACCA (TVA) conditions Amps = outdoor unit amps (comp.+fan)
 High and low pressures are measured at the liquid and suction service valves. Design Subcooling 9 ±3 °F @ the liquid service valve, ARI 95 test conditions

EXPANDED COOLING DATA — GSH130481A* / ARUF61-00*-1* / ARUF48601A*

IDB	Airflow	Outdoor Ambient Temperature																								
		65°F				75°F				85°F				95°F				105°F				115°F				
		59	63	67	71	59	63	67	71	59	63	67	71	59	63	67	71	59	63	67	71	59	63	67	71	
1800	MBh	44.1	45.7	50.1	-	43.1	44.6	48.9	-	42.0	43.6	47.7	-	41.0	42.5	46.6	-	39.0	40.4	44.3	-	36.1	37.4	41.0	-	
	S/T	0.76	0.63	0.44	-	0.79	0.66	0.46	-	0.81	0.67	0.47	-	0.83	0.70	0.48	-	0.86	0.72	0.50	-	0.87	0.73	0.50	-	
	ΔT	17	15	11	-	17	15	11	-	17	15	11	-	17	15	11	-	17	15	11	-	16	14	11	-	
	kW	3.22	3.28	3.37	-	3.44	3.51	3.61	-	3.64	3.71	3.82	-	3.81	3.89	4.01	-	3.96	4.04	4.17	-	4.09	4.17	4.30	-	
	Amps	12.1	12.4	12.8	-	13.0	13.4	13.8	-	14.2	14.5	15.0	-	15.1	15.5	16.0	-	16.1	16.5	17.0	-	17.1	17.5	18.1	-	
	Hi PR	142	153	161	-	159	172	181	-	181	195	206	-	207	222	235	-	232	250	264	-	257	276	292	-	
	Lo PR	64	68	74	-	67	72	78	-	70	75	81	-	74	78	86	-	77	82	90	-	80	85	93	-	
	70	MBh	42.8	44.4	48.6	-	41.8	43.3	47.5	-	40.8	42.3	46.4	-	39.8	41.3	45.2	-	37.8	39.2	43.0	-	35.0	36.3	39.8	-
		S/T	0.72	0.60	0.42	-	0.75	0.63	0.43	-	0.77	0.64	0.45	-	0.79	0.66	0.46	-	0.82	0.69	0.48	-	0.83	0.69	0.48	-
		ΔT	18	15	12	-	18	16	12	-	18	16	12	-	18	16	12	-	18	16	12	-	17	14	11	-
kW		3.20	3.26	3.35	-	3.42	3.48	3.58	-	3.61	3.68	3.79	-	3.78	3.86	3.98	-	3.93	4.01	4.13	-	4.06	4.14	4.27	-	
Amps		12.0	12.3	12.7	-	12.9	13.2	13.7	-	14.0	14.4	14.8	-	15.0	15.4	15.9	-	16.0	16.3	16.9	-	16.9	17.3	17.9	-	
Hi PR		141	151	160	-	158	170	179	-	180	193	204	-	205	220	232	-	230	248	261	-	254	274	289	-	
Lo PR		63	67	73	-	67	71	78	-	69	74	81	-	73	78	85	-	76	81	89	-	79	84	92	-	
1400		MBh	39.5	41.0	44.9	-	38.6	40.0	43.8	-	37.7	39.1	42.8	-	36.8	38.1	41.7	-	34.9	36.2	39.7	-	32.3	33.5	36.7	-
		S/T	0.70	0.58	0.40	-	0.72	0.60	0.42	-	0.74	0.62	0.43	-	0.77	0.64	0.44	-	0.79	0.66	0.46	-	0.80	0.67	0.46	-
		ΔT	18	16	12	-	18	16	12	-	18	16	12	-	18	16	12	-	18	16	12	-	17	15	11	-
	kW	3.13	3.19	3.28	-	3.34	3.41	3.50	-	3.53	3.60	3.71	-	3.70	3.77	3.89	-	3.84	3.92	4.04	-	3.96	4.04	4.17	-	
	Amps	11.7	11.9	12.3	-	12.6	12.9	13.3	-	13.7	14.0	14.4	-	14.6	14.9	15.4	-	15.5	15.9	16.4	-	16.4	16.8	17.4	-	
	Hi PR	136	147	155	-	153	165	174	-	174	187	198	-	198	213	225	-	223	240	254	-	247	265	280	-	
	Lo PR	61	65	71	-	65	69	75	-	67	72	78	-	71	75	82	-	74	79	86	-	77	82	89	-	

1800	MBh	44.8	46.2	50.0	53.6	43.8	45.1	48.8	52.4	42.8	44.0	47.7	51.1	41.7	42.9	46.5	49.9	39.6	40.8	44.2	47.4	36.7	37.8	40.9	43.9	
	S/T	0.86	0.77	0.58	0.38	0.89	0.80	0.61	0.39	0.92	0.82	0.62	0.40	0.95	0.85	0.64	0.41	0.98	0.88	0.66	0.43	0.99	0.89	0.67	0.43	
	ΔT	20	18	15	10	20	18	15	10	20	18	15	10	20	19	15	11	20	18	15	10	19	17	14	10	
	kW	3.24	3.30	3.40	3.50	3.47	3.54	3.64	3.75	3.67	3.74	3.85	3.97	3.84	3.92	4.04	4.16	3.99	4.07	4.20	4.33	4.12	4.21	4.34	4.47	
	Amps	12.2	12.5	12.9	13.4	13.2	13.5	13.9	14.4	14.3	14.6	15.1	15.7	15.3	15.6	16.2	16.8	16.2	16.6	17.2	17.9	17.2	17.6	18.2	18.9	
	Hi PR	144	154	163	170	161	173	183	191	183	197	208	217	209	225	237	247	235	253	267	278	259	279	295	307	
	Lo PR	65	69	75	80	68	73	79	84	71	75	82	88	74	79	86	92	78	83	91	96	81	86	94	100	
	75	MBh	43.5	44.8	48.5	52.1	42.5	43.8	47.4	50.9	41.5	42.7	46.3	49.7	40.5	41.7	45.1	48.4	38.5	39.6	42.9	46.0	35.6	36.7	39.7	42.6
		S/T	0.82	0.74	0.56	0.36	0.85	0.76	0.58	0.37	0.87	0.78	0.59	0.38	0.90	0.81	0.61	0.39	0.94	0.84	0.63	0.41	0.94	0.84	0.64	0.41
		ΔT	21	19	16	11	21	19	16	11	21	19	16	11	21	19	16	11	21	19	16	11	19	18	15	10
kW		3.22	3.28	3.37	3.47	3.44	3.51	3.61	3.72	3.64	3.71	3.82	3.94	3.81	3.89	4.01	4.13	3.96	4.04	4.17	4.30	4.09	4.17	4.30	4.44	
Amps		12.1	12.4	12.8	13.2	13.0	13.4	13.8	14.3	14.2	14.5	15.0	15.5	15.1	15.5	16.0	16.6	16.1	16.5	17.0	17.7	17.1	17.5	18.1	18.7	
Hi PR		142	153	162	168	159	172	181	189	181	195	206	215	207	222	235	245	232	250	264	275	257	276	292	304	
Lo PR		64	68	74	79	68	72	78	83	70	75	81	87	74	78	86	91	77	82	90	96	80	85	93	99	
1400		MBh	40.2	41.4	44.8	48.1	39.3	40.4	43.7	46.9	38.3	39.5	42.7	45.8	37.4	38.5	41.7	44.7	35.5	36.6	39.6	42.5	32.9	33.9	36.7	39.3
		S/T	0.79	0.71	0.54	0.35	0.82	0.74	0.56	0.36	0.84	0.75	0.57	0.37	0.87	0.78	0.59	0.38	0.90	0.81	0.61	0.39	0.91	0.81	0.62	0.40
		ΔT	21	19	16	11	21	20	16	11	21	20	16	11	21	20	16	11	21	19	16	11	20	18	15	10
	kW	3.15	3.21	3.30	3.40	3.37	3.43	3.53	3.64	3.56	3.63	3.74	3.85	3.73	3.80	3.92	4.04	3.87	3.95	4.07	4.20	3.99	4.08	4.20	4.33	
	Amps	11.8	12.0	12.4	12.9	12.7	13.0	13.4	13.9	13.8	14.1	14.6	15.1	14.7	15.1	15.6	16.2	15.7	16.0	16.6	17.2	16.6	17.0	17.6	18.2	
	Hi PR	138	148	157	163	155	166	176	183	176	189	200	209	200	216	228	238	225	243	256	267	249	268	283	295	
	Lo PR	62	66	72	77	65	70	76	81	68	72	79	84	71	76	83	88	75	80	87	93	77	82	90	96	

IDB: Entering Indoor Dry Bulb Temperature kW = Total system power Shaded area reflects ACCA (TVA) conditions Amps = outdoor unit amps (comp.+fan)
 High and low pressures are measured at the liquid and suction service valves. Design Subcooling 9 ±3 °F @ the liquid service valve, ARI 95 test conditions

EXPANDED COOLING DATA — GSH130481A* / ARUF61-00*-1* / ARUF48601A* (CONT.)

IDB	Airflow	Outdoor Ambient Temperature																							
		65°F				75°F				85°F				95°F				105°F				115°F			
		Entering Indoor Wet Bulb Temperature																							
		59	63	67	71	59	63	67	71	59	63	67	71	59	63	67	71	59	63	67	71	59	63	67	71
1800	MBh	45.6	46.6	49.8	53.3	44.6	45.6	48.7	52.0	43.5	44.5	47.5	50.8	42.5	43.4	46.4	49.5	40.3	41.2	44.0	47.1	37.4	38.2	40.8	43.6
	S/T	0.95	0.89	0.72	0.54	1.00	0.92	0.75	0.56	1.00	0.94	0.77	0.57	1.00	1.00	0.79	0.59	1.00	1.00	0.82	0.61	1.00	1.00	0.83	0.62
	ΔT	22	21	18	15	23	21	19	15	22	21	19	15	22	22	19	15	21	21	18	15	19	19	17	14
	kW	3.27	3.33	3.42	3.52	3.49	3.56	3.67	3.78	3.69	3.77	3.88	4.00	3.87	3.95	4.07	4.20	4.02	4.11	4.23	4.37	4.15	4.24	4.37	4.51
	Amps	12.3	12.6	13.0	13.5	13.3	13.6	14.0	14.6	14.4	14.8	15.3	15.8	15.4	15.8	16.3	16.9	16.4	16.8	17.4	18.0	17.4	17.8	18.4	19.1
	Hi PR	145	156	165	172	163	175	185	193	185	199	210	219	211	227	240	250	237	255	269	281	262	282	298	311
	Lo PR	65	69	76	81	69	73	80	85	72	76	83	89	75	80	87	93	79	84	92	97	81	87	95	101
80	MBh	44.3	45.3	48.4	51.7	43.3	44.2	47.3	50.5	42.3	43.2	46.1	49.3	41.2	42.1	45.0	48.1	39.2	40.0	42.8	45.7	36.3	37.1	39.6	42.3
	S/T	0.90	0.85	0.69	0.51	0.94	0.88	0.71	0.53	0.96	0.90	0.73	0.55	0.99	0.93	0.76	0.56	1.00	0.96	0.78	0.59	1.00	0.97	0.79	0.59
	ΔT	23	22	19	15	23	22	19	15	23	22	19	16	23	22	20	16	23	22	19	15	21	21	18	14
	kW	3.24	3.30	3.40	3.50	3.47	3.54	3.64	3.75	3.67	3.74	3.85	3.97	3.84	3.92	4.04	4.17	3.99	4.07	4.20	4.33	4.12	4.21	4.34	4.47
	Amps	12.2	12.5	12.9	13.4	13.2	13.5	13.9	14.4	14.3	14.6	15.1	15.7	15.3	15.6	16.2	16.8	16.3	16.6	17.2	17.9	17.2	17.6	18.2	18.9
	Hi PR	144	155	163	170	161	173	183	191	183	197	208	217	209	225	237	247	235	253	267	278	259	279	295	307
	Lo PR	65	69	75	80	68	73	79	84	71	75	82	88	74	79	86	92	78	83	91	96	81	86	94	100
1400	MBh	40.9	41.8	44.7	47.7	39.9	40.8	43.6	46.6	39.0	39.8	42.6	45.5	38.0	38.9	41.5	44.4	36.1	36.9	39.5	42.2	33.5	34.2	36.6	39.1
	S/T	0.87	0.82	0.66	0.50	0.90	0.85	0.69	0.51	0.92	0.87	0.71	0.53	0.95	0.90	0.73	0.54	0.99	0.93	0.76	0.57	1.00	0.94	0.76	0.57
	ΔT	23	22	19	16	24	23	20	16	24	23	20	16	24	23	20	16	24	23	20	16	22	21	18	15
	kW	3.17	3.23	3.32	3.42	3.39	3.46	3.56	3.66	3.58	3.66	3.76	3.88	3.75	3.83	3.95	4.07	3.90	3.98	4.10	4.23	4.03	4.11	4.23	4.37
	Amps	11.9	12.1	12.5	13.0	12.8	13.1	13.5	14.0	13.9	14.2	14.7	15.3	14.9	15.2	15.7	16.3	15.8	16.2	16.7	17.4	16.7	17.1	17.7	18.4
	Hi PR	139	150	158	165	156	168	178	185	178	191	202	211	202	218	230	240	228	245	259	270	252	271	286	298
	Lo PR	63	67	73	77	66	70	77	82	69	73	80	85	72	77	84	89	76	81	88	94	78	83	91	97

1800	MBh	46.4	47.3	49.6	52.9	45.4	46.2	48.4	51.7	44.3	45.1	47.3	50.4	43.2	44.0	46.1	49.2	41.0	41.8	43.8	46.7	38.0	38.8	40.6	43.3
	S/T	0.99	0.96	0.86	0.70	1.00	0.99	0.90	0.73	1.00	1.00	0.92	0.74	1.00	1.00	0.95	0.77	1.00	1.00	0.98	0.80	1.00	1.00	0.99	0.80
	ΔT	24	23	22	19	23	23	22	19	23	23	22	19	22	22	22	19	21	21	22	19	19	20	21	18
	kW	3.29	3.35	3.45	3.55	3.52	3.59	3.69	3.81	3.72	3.80	3.91	4.03	3.90	3.98	4.10	4.23	4.05	4.14	4.27	4.40	4.19	4.27	4.41	4.55
	Amps	12.4	12.7	13.1	13.6	13.4	13.7	14.2	14.7	14.6	14.9	15.4	16.0	15.6	15.9	16.5	17.1	16.6	17.0	17.5	18.2	17.5	18.0	18.6	19.3
	Hi PR	146	158	166	174	164	177	187	195	187	201	212	222	213	229	242	252	239	258	272	284	265	285	301	314
	Lo PR	66	70	76	81	70	74	81	86	72	77	84	89	76	81	88	94	80	85	92	98	82	88	96	102
85	MBh	45.1	46.0	48.1	51.4	44.0	44.9	47.0	50.2	43.0	43.8	45.9	49.0	41.9	42.8	44.8	47.8	39.8	40.6	42.5	45.4	36.9	37.6	39.4	42.0
	S/T	0.95	0.91	0.82	0.67	0.98	0.95	0.85	0.69	1.00	0.97	0.88	0.71	1.00	1.00	0.90	0.73	1.00	1.00	0.94	0.76	1.00	1.00	0.95	0.77
	ΔT	25	24	23	20	25	24	23	20	25	24	23	20	24	25	23	20	23	23	23	20	21	22	21	19
	kW	3.27	3.33	3.42	3.52	3.49	3.56	3.67	3.78	3.69	3.77	3.88	4.00	3.87	3.95	4.07	4.20	4.02	4.11	4.23	4.37	4.15	4.24	4.37	4.51
	Amps	12.3	12.6	13.0	13.5	13.3	13.6	14.0	14.6	14.4	14.8	15.3	15.8	15.4	15.8	16.3	16.9	16.4	16.8	17.4	18.0	17.4	17.8	18.4	19.1
	Hi PR	145	156	165	172	163	175	185	193	185	199	210	219	211	227	240	250	237	255	269	281	262	282	298	311
	Lo PR	65	69	76	81	69	73	80	85	72	76	83	89	75	80	87	93	79	84	92	97	81	87	95	101
1400	MBh	41.6	42.4	44.4	47.4	40.6	41.4	43.4	46.3	39.7	40.4	42.4	45.2	38.7	39.5	41.3	44.1	36.8	37.5	39.3	41.9	34.1	34.7	36.4	38.8
	S/T	0.91	0.88	0.79	0.64	0.95	0.91	0.82	0.67	0.97	0.94	0.84	0.68	1.00	0.97	0.87	0.71	1.00	1.00	0.90	0.73	1.00	1.00	0.91	0.74
	ΔT	25	25	23	20	25	25	23	20	25	25	23	20	25	25	24	20	24	25	23	20	22	23	22	19
	kW	3.19	3.26	3.35	3.45	3.42	3.48	3.58	3.69	3.61	3.68	3.79	3.91	3.78	3.86	3.98	4.10	3.93	4.01	4.13	4.26	4.06	4.14	4.27	4.40
	Amps	12.0	12.3	12.6	13.1	12.9	13.2	13.7	14.2	14.0	14.4	14.8	15.4	15.0	15.4	15.9	16.5	15.9	16.3	16.9	17.5	16.9	17.3	17.9	18.6
	Hi PR	141	151	160	167	158	170	179	187	180	193	204	213	204	220	232	242	230	248	261	273	254	273	289	301
	Lo PR	63	67	73	78	67	71	78	83	69	74	81	86	73	78	85	90	76	81	89	95	79	84	92	98

IDB: Entering Indoor Dry Bulb Temperature kW = Total system power Shaded area reflects ARI Rating conditions Amps = outdoor unit amps (comp.+fan)
High and low pressures are measured at the liquid and suction service valves. Design Subcooling 9 ±3 °F @ the liquid service valve, ARI 95 test conditions

EXPANDED COOLING DATA — GSH130483A* / ARUF61-00*-1* / ARUF48601A*

IDB	Airflow	Outdoor Ambient Temperature																								
		65°F				75°F				85°F				95°F				105°F				115°F				
		59	63	67	71	59	63	67	71	59	63	67	71	59	63	67	71	59	63	67	71	59	63	67	71	
70	1800	MBh	44.1	45.7	50.1	-	43.1	44.6	48.9	-	42.0	43.6	47.7	-	41.0	42.5	46.6	-	39.0	40.4	44.3	-	36.1	37.4	41.0	-
		S/T	0.76	0.63	0.44	-	0.79	0.66	0.46	-	0.81	0.67	0.47	-	0.83	0.70	0.48	-	0.86	0.72	0.50	-	0.87	0.73	0.50	-
		ΔT	17	15	11	-	17	15	11	-	17	15	11	-	17	15	11	-	17	15	11	-	16	14	11	-
		kW	3.10	3.17	3.27	-	3.34	3.41	3.52	-	3.55	3.62	3.74	-	3.73	3.81	3.93	-	3.88	3.97	4.10	-	4.02	4.11	4.24	-
		Amps	10.0	10.2	10.5	-	10.8	11.0	11.4	-	11.7	11.9	12.3	-	12.4	12.7	13.2	-	13.2	13.5	14.0	-	14.0	14.3	14.8	-
	1600	Hi PR	145	156	165	-	163	175	185	-	185	199	211	-	211	227	240	-	237	256	270	-	262	282	298	-
		Lo PR	62	66	72	-	65	70	76	-	68	72	79	-	71	76	83	-	75	80	87	-	77	82	90	-
		MBh	42.8	44.4	48.6	-	41.8	43.3	47.5	-	40.8	42.3	46.4	-	39.8	41.3	45.2	-	37.8	39.2	43.0	-	35.0	36.3	39.8	-
		S/T	0.72	0.60	0.42	-	0.75	0.63	0.43	-	0.77	0.64	0.45	-	0.79	0.66	0.46	-	0.82	0.69	0.48	-	0.83	0.69	0.48	-
		ΔT	18	15	12	-	18	16	12	-	18	16	12	-	18	16	12	-	18	16	12	-	17	14	11	-
1400	kW	3.08	3.14	3.24	-	3.31	3.38	3.49	-	3.52	3.59	3.71	-	3.70	3.78	3.90	-	3.85	3.94	4.07	-	3.99	4.07	4.21	-	
	Amps	9.9	10.1	10.5	-	10.7	10.9	11.3	-	11.6	11.8	12.2	-	12.3	12.6	13.0	-	13.1	13.4	13.9	-	13.9	14.2	14.7	-	
	Hi PR	144	155	163	-	161	174	183	-	184	197	209	-	209	225	238	-	235	253	267	-	260	280	295	-	
	Lo PR	61	65	71	-	65	69	75	-	67	72	78	-	71	75	82	-	74	79	86	-	77	82	89	-	
	MBh	39.5	41.0	44.9	-	38.6	40.0	43.8	-	37.7	39.1	42.8	-	36.8	38.1	41.7	-	34.9	36.2	39.7	-	32.3	33.5	36.7	-	

75	1800	MBh	44.8	46.2	50.0	53.6	43.8	45.1	48.8	52.4	42.8	44.0	47.7	51.1	41.7	42.9	46.5	49.9	39.6	40.8	44.2	47.4	36.7	37.8	40.9	43.9
		S/T	0.86	0.77	0.58	0.38	0.89	0.80	0.61	0.39	0.92	0.82	0.62	0.40	0.95	0.85	0.64	0.41	0.98	0.88	0.66	0.43	0.99	0.89	0.67	0.43
		ΔT	20	18	15	10	20	18	15	10	20	18	15	10	20	19	15	11	20	18	15	10	19	17	14	10
		kW	3.13	3.19	3.29	3.40	3.37	3.44	3.55	3.66	3.58	3.65	3.77	3.89	3.76	3.84	3.97	4.10	3.92	4.00	4.14	4.27	4.05	4.14	4.28	4.43
		Amps	10.1	10.3	10.6	11.0	10.9	11.1	11.5	11.9	11.8	12.1	12.4	12.9	12.6	12.9	13.3	13.8	13.3	13.7	14.1	14.6	14.1	14.5	14.9	15.5
	1600	Hi PR	147	158	167	174	165	177	187	195	187	201	213	222	213	229	242	253	240	258	273	284	265	285	301	314
		Lo PR	63	67	73	77	66	70	77	82	69	73	80	85	72	77	84	89	76	81	88	94	78	83	91	97
		MBh	43.5	44.8	48.5	52.1	42.5	43.8	47.4	50.9	41.5	42.7	46.3	49.7	40.5	41.7	45.1	48.4	38.5	39.6	42.9	46.0	35.6	36.7	39.7	42.6
		S/T	0.82	0.74	0.56	0.36	0.85	0.76	0.58	0.37	0.87	0.78	0.59	0.38	0.90	0.81	0.61	0.39	0.94	0.84	0.63	0.41	0.94	0.84	0.64	0.41
		ΔT	21	19	16	11	21	19	16	11	21	19	16	11	21	19	16	11	21	19	16	11	19	18	15	10
1400	kW	3.10	3.17	3.27	3.37	3.34	3.41	3.52	3.63	3.55	3.62	3.74	3.86	3.73	3.81	3.94	4.07	3.89	3.97	4.10	4.24	4.02	4.11	4.25	4.39	
	Amps	10.0	10.2	10.5	10.9	10.8	11.0	11.4	11.8	11.7	11.9	12.3	12.8	12.5	12.7	13.2	13.6	13.2	13.5	14.0	14.5	14.0	14.3	14.8	15.4	
	Hi PR	145	156	165	172	163	175	185	193	185	199	211	220	211	227	240	250	238	256	270	282	262	282	298	311	
	Lo PR	62	66	72	77	65	70	76	81	68	72	79	84	71	76	83	88	75	80	87	93	77	82	90	96	
	MBh	40.2	41.4	44.8	48.1	39.3	40.4	43.7	46.9	38.3	39.5	42.7	45.8	37.4	38.5	41.7	44.7	35.5	36.6	39.6	42.5	32.9	33.9	36.7	39.3	

IDB: Entering Indoor Dry Bulb Temperature kW = Total system power Shaded area reflects ACCA (TVA) conditions Amps = outdoor unit amps (comp.+fan)
 High and low pressures are measured at the liquid and suction service valves. Design Subcooling 9 ±3 °F @ the liquid service valve, ARI 95 test conditions

EXPANDED COOLING DATA — GSH130483A* / ARUF61-00*-1* / ARUF48601A* (CONT.)

IDB	Airflow	Outdoor Ambient Temperature																																																																																																																																																																																	
		65°F								75°F								85°F								95°F								105°F								115°F																																																																																																																																									
		59	63	67	71	59	63	67	71	59	63	67	71	59	63	67	71	59	63	67	71	59	63	67	71	59	63	67	71	59	63	67	71																																																																																																																																																		
80	1800	MBh	45.6	46.6	49.8	53.3	44.6	45.6	48.7	52.0	43.5	44.5	47.5	50.8	42.5	43.4	46.4	49.5	40.3	41.2	44.0	47.1	37.4	38.2	40.8	43.6	S/T	0.95	0.89	0.72	0.54	1.00	0.92	0.75	0.56	1.00	0.94	0.77	0.57	1.00	1.00	0.79	0.59	1.00	1.00	0.82	0.61	1.00	1.00	0.83	0.62	ΔT	22	21	18	15	22	21	19	15	22	21	19	15	22	22	22	19	15	21	21	18	15	19	19	17	14	kW	3.15	3.22	3.32	3.42	3.39	3.46	3.58	3.69	3.60	3.68	3.80	3.93	3.79	3.87	4.00	4.13	3.95	4.04	4.17	4.31	4.09	4.18	4.32	4.46	Amps	10.2	10.4	10.7	11.1	11.0	11.2	11.6	12.0	11.9	12.2	12.6	13.0	12.7	13.0	13.4	13.9	13.5	13.8	14.2	14.8	14.3	14.6	15.1	15.6	Hi-PR	148	159	168	176	166	179	189	197	189	204	215	224	215	232	245	255	242	261	275	287	268	288	304	317	Lo-PR	63	67	73	78	67	71	78	83	69	74	81	86	73	78	85	90	76	81	89	95	79	84	92	98		
		1600	MBh	44.3	45.3	48.4	51.7	43.3	44.2	47.3	50.5	42.3	43.2	46.1	49.3	41.2	42.1	45.0	48.1	39.2	40.0	42.8	45.7	36.3	37.1	39.6	42.3	S/T	0.90	0.85	0.69	0.51	0.94	0.88	0.71	0.53	0.96	0.90	0.73	0.55	0.99	0.93	0.76	0.56	1.00	0.96	0.78	0.59	1.00	0.97	0.79	0.59	ΔT	23	22	19	15	23	22	19	15	23	22	19	16	23	22	20	16	23	22	19	15	21	21	18	14	kW	3.13	3.19	3.29	3.40	3.37	3.44	3.55	3.66	3.58	3.65	3.77	3.89	3.76	3.84	3.97	4.10	3.92	4.00	4.14	4.27	4.05	4.14	4.28	4.43	Amps	10.1	10.3	10.6	11.0	10.9	11.1	11.5	11.9	11.8	12.1	12.4	12.9	12.6	12.9	13.3	13.8	13.4	13.7	14.1	14.6	14.1	14.5	14.9	15.5	Hi-PR	147	158	167	174	165	177	187	195	187	202	213	222	213	230	242	253	240	258	273	284	265	285	301	314	Lo-PR	63	67	73	77	66	70	77	82	69	73	80	85	72	77	84	89	76	81	88	94	78	83	91	97		
			1400	MBh	40.9	41.8	44.7	47.7	39.9	40.8	43.6	46.6	39.0	39.8	42.6	45.5	38.0	38.9	41.5	44.4	36.1	36.9	39.5	42.2	33.5	34.2	36.6	39.1	S/T	0.87	0.82	0.66	0.50	0.90	0.85	0.69	0.51	0.92	0.87	0.71	0.53	0.95	0.90	0.73	0.54	0.99	0.93	0.76	0.57	1.00	0.94	0.76	0.57	ΔT	23	22	19	16	24	23	20	16	24	23	20	16	24	23	20	16	24	23	20	16	22	21	18	15	kW	3.05	3.12	3.21	3.32	3.28	3.35	3.46	3.57	3.49	3.56	3.68	3.80	3.67	3.75	3.87	4.00	3.82	3.90	4.03	4.17	3.95	4.04	4.17	4.31	Amps	9.8	10.0	10.4	10.7	10.6	10.8	11.2	11.6	11.5	11.7	12.1	12.6	12.2	12.5	12.9	13.4	13.0	13.3	13.7	14.2	13.7	14.1	14.5	15.1	Hi-PR	142	153	162	169	160	172	181	189	182	195	206	215	207	223	235	245	233	250	264	276	257	277	292	305	Lo-PR	61	65	71	75	64	68	75	79	67	71	77	82	70	75	81	87	73	78	85	91	76	81	88	94	
				85	1800	MBh	46.4	47.3	49.6	52.9	45.4	46.2	48.4	51.7	44.3	45.1	47.3	50.4	43.2	44.0	46.1	49.2	41.0	41.8	43.8	46.7	38.0	38.8	40.6	43.3	S/T	0.99	0.96	0.86	0.70	1.00	0.99	0.90	0.73	1.00	1.00	0.92	0.74	1.00	1.00	0.95	0.77	1.00	1.00	0.98	0.80	1.00	1.00	0.99	0.80	ΔT	24	23	22	19	23	23	22	19	23	23	22	19	22	22	22	19	21	21	22	19	19	20	21	18	kW	3.18	3.24	3.35	3.45	3.42	3.49	3.60	3.72	3.63	3.71	3.83	3.96	3.82	3.91	4.03	4.17	3.98	4.07	4.21	4.35	4.12	4.21	4.35	4.50	Amps	10.3	10.5	10.8	11.2	11.1	11.3	11.7	12.1	12.0	12.3	12.7	13.1	12.8	13.1	13.5	14.0	13.6	13.9	14.4	14.9	14.4	14.7	15.2	15.8	Hi-PR	150	161	170	177	168	181	191	199	191	206	217	226	218	234	247	258	245	263	278	290	270	291	307	321	Lo-PR	64	68	74	79	67	72	78	83	70	75	81	87	74	78	86	91	77	82	90	95	80	85	93
	1600					MBh	45.1	46.0	48.1	51.4	44.0	44.9	47.0	50.2	43.0	43.8	45.9	49.0	41.9	42.8	44.8	47.8	39.8	40.6	42.5	45.4	36.9	37.6	39.4	42.0	S/T	0.95	0.91	0.82	0.67	0.98	0.95	0.85	0.69	1.00	0.97	0.88	0.71	1.00	1.00	0.90	0.73	1.00	1.00	0.94	0.76	1.00	1.00	0.95	0.77	ΔT	25	24	23	20	25	24	23	20	24	25	23	20	24	25	23	20	23	23	23	20	21	22	21	19	kW	3.15	3.22	3.32	3.42	3.39	3.46	3.58	3.69	3.60	3.68	3.80	3.93	3.79	3.87	4.00	4.13	3.95	4.04	4.17	4.31	4.09	4.18	4.32	4.46	Amps	10.2	10.4	10.7	11.1	11.0	11.2	11.6	12.0	11.9	12.2	12.6	13.0	12.7	13.0	13.4	13.9	13.5	13.8	14.2	14.8	14.3	14.6	15.1	15.6	Hi-PR	148	159	168	176	166	179	189	197	189	204	215	224	215	232	245	255	242	261	275	287	268	288	304	317	Lo-PR	63	67	73	78	67	71	78	83	69	74	81	86	73	78	85	90	76	81	89	95	79	84	92
		1400				MBh	41.6	42.4	44.4	47.4	40.6	41.4	43.4	46.3	39.7	40.4	42.4	45.2	38.7	39.5	41.3	44.1	36.8	37.5	39.3	41.9	34.1	34.7	36.4	38.8	S/T	0.91	0.88	0.79	0.64	0.95	0.91	0.82	0.67	0.97	0.94	0.84	0.68	1.00	0.97	0.87	0.71	1.00	1.00	0.90	0.73	1.00	1.00	0.91	0.74	ΔT	25	25	23	20	25	25	23	20	25	25	23	20	25	25	24	20	24	25	23	20	22	23	22	19	kW	3.08	3.14	3.24	3.34	3.31	3.38	3.49	3.60	3.52	3.59	3.71	3.83	3.70	3.78	3.90	4.03	3.85	3.94	4.07	4.20	3.99	4.07	4.21	4.35	Amps	9.9	10.1	10.4	10.8	10.7	10.9	11.3	11.7	11.6	11.8	12.2	12.7	12.3	12.6	13.0	13.5	13.1	13.4	13.9	14.4	13.9	14.2	14.7	15.2	Hi-PR	144	155	163	170	161	174	183	191	183	197	208	217	209	225	237	248	235	253	267	279	260	279	295	308	Lo-PR	61	65	71	76	65	69	75	80	67	72	78	83	71	75	82	88	74	79	86	92	77	82	89

IDB: Entering Indoor Dry Bulb Temperature kW = Total system power Shaded area reflects ARI Rating conditions Amps = outdoor unit amps (comp.+fan)
 High and low pressures are measured at the liquid and suction service valves. Design Subcooling 9 ±3 °F @ the liquid service valve, ARI 95 test conditions

EXPANDED COOLING DATA — GSH130484A* / ARUF61-00*-1* / ARUF48601A*

IDB	Airflow	Outdoor Ambient Temperature																							
		65°F				75°F				85°F				95°F				105°F				115°F			
		59	63	67	71	59	63	67	71	59	63	67	71	59	63	67	71	59	63	67	71	59	63	67	71
1800	MBh	44.1	45.7	50.1	-	43.1	44.6	48.9	-	42.0	43.6	47.7	-	41.0	42.5	46.6	-	39.0	40.4	44.3	-	36.1	37.4	41.0	-
	S/T	0.75	0.63	0.44	-	0.78	0.65	0.45	-	0.80	0.67	0.46	-	0.83	0.69	0.48	-	0.86	0.72	0.50	-	0.86	0.72	0.50	-
	ΔT	17	15	11	-	17	15	11	-	17	15	11	-	17	15	11	-	17	15	11	-	16	14	10	-
	kW	3.02	3.10	3.21	-	3.29	3.37	3.49	-	3.52	3.61	3.74	-	3.73	3.83	3.97	-	3.91	4.01	4.16	-	4.06	4.16	4.32	-
	Amps	2.3	2.4	2.4	-	2.5	2.5	2.6	-	2.6	2.7	2.8	-	2.8	2.9	2.9	-	2.9	3.0	3.1	-	3.1	3.2	3.3	-
	Hi PR	150	162	171	-	169	182	192	-	192	207	218	-	219	235	249	-	246	265	280	-	272	293	309	-
	Lo PR	63	67	73	-	66	70	77	-	69	73	80	-	72	77	84	-	76	81	88	-	78	83	91	-
	MBh	42.8	44.4	48.6	-	41.8	43.3	47.5	-	40.8	42.3	46.4	-	39.8	41.3	45.2	-	37.8	39.2	43.0	-	35.0	36.3	39.8	-
	S/T	0.72	0.60	0.42	-	0.74	0.62	0.43	-	0.76	0.64	0.44	-	0.79	0.66	0.46	-	0.82	0.68	0.47	-	0.82	0.69	0.48	-
	ΔT	18	15	12	-	18	15	12	-	18	16	12	-	18	16	12	-	18	15	12	-	17	14	11	-
70	kW	2.99	3.07	3.18	-	3.26	3.34	3.46	-	3.49	3.58	3.71	-	3.70	3.79	3.93	-	3.87	3.97	4.12	-	4.03	4.13	4.28	-
	Amps	2.3	2.3	2.4	-	2.4	2.5	2.6	-	2.6	2.7	2.7	-	2.8	2.8	2.9	-	2.9	3.0	3.1	-	3.1	3.1	3.2	-
	Hi PR	149	160	169	-	167	180	190	-	190	205	216	-	217	233	246	-	244	262	277	-	269	290	306	-
	Lo PR	62	66	72	-	66	70	76	-	68	72	79	-	72	76	83	-	75	80	87	-	78	82	90	-
	MBh	39.5	41.0	44.9	-	38.6	40.0	43.8	-	37.7	39.1	42.8	-	36.8	38.1	41.7	-	34.9	36.2	39.7	-	32.3	33.5	36.7	-
	S/T	0.69	0.58	0.40	-	0.72	0.60	0.42	-	0.74	0.61	0.43	-	0.76	0.63	0.44	-	0.79	0.66	0.46	-	0.80	0.66	0.46	-
	ΔT	18	16	12	-	18	16	12	-	18	16	12	-	18	16	12	-	18	16	12	-	17	15	11	-
	kW	2.91	2.98	3.09	-	3.17	3.25	3.36	-	3.40	3.48	3.61	-	3.60	3.68	3.82	-	3.77	3.86	4.00	-	3.91	4.01	4.16	-
	Amps	2.2	2.3	2.3	-	2.4	2.4	2.5	-	2.6	2.6	2.7	-	2.7	2.8	2.8	-	2.9	2.9	3.0	-	3.0	3.1	3.2	-
	Hi PR	145	156	164	-	162	175	184	-	184	198	210	-	210	226	239	-	236	254	269	-	261	281	297	-
Lo PR	60	64	70	-	64	68	74	-	66	70	77	-	69	74	81	-	73	77	84	-	75	80	87	-	

1800	MBh	44.84	46.17	49.98	53.64	43.80	45.10	48.81	52.39	42.76	44.02	47.65	51.14	41.72	42.95	46.49	49.89	39.63	40.80	44.16	47.40	36.71	37.80	40.91	43.91
	S/T	0.86	0.77	0.58	0.37	0.89	0.79	0.60	0.39	0.91	0.81	0.62	0.40	0.94	0.84	0.64	0.41	0.97	0.87	0.66	0.42	0.98	0.88	0.67	0.43
	ΔT	20	18	15	10	20	18	15	10	20	18	15	10	20	18	15	10	20	18	15	10	18	17	14	10
	kW	3.05	3.12	3.24	3.36	3.32	3.40	3.53	3.66	3.56	3.65	3.78	3.92	3.77	3.86	4.00	4.15	3.95	4.05	4.20	4.35	4.10	4.20	4.36	4.52
	Amps	2.3	2.4	2.4	2.5	2.5	2.5	2.6	2.7	2.7	2.7	2.8	2.9	2.8	2.9	3.0	3.1	3.0	3.0	3.1	3.2	3.1	3.2	3.3	3.4
	Hi PR	152	164	173	180	171	184	194	202	194	209	220	230	221	238	251	262	249	268	282	295	275	296	312	326
	Lo PR	63	67	73	78	67	71	78	83	69	74	81	86	73	78	85	90	76	81	89	95	79	84	92	98
	MBh	43.5	44.8	48.5	52.1	42.5	43.8	47.4	50.9	41.5	42.7	46.3	49.7	40.5	41.7	45.1	48.4	38.5	39.6	42.9	46.0	35.6	36.7	39.7	42.6
	S/T	0.82	0.73	0.55	0.36	0.85	0.76	0.57	0.37	0.87	0.78	0.59	0.38	0.90	0.80	0.61	0.39	0.93	0.83	0.63	0.40	0.94	0.84	0.63	0.41
	ΔT	20	19	15	11	21	19	16	11	21	19	16	11	21	19	16	11	21	19	16	11	19	18	14	10
75	kW	3.02	3.10	3.21	3.33	3.29	3.37	3.49	3.62	3.53	3.61	3.74	3.88	3.73	3.83	3.97	4.12	3.91	4.01	4.16	4.31	4.06	4.16	4.32	4.48
	Amps	2.3	2.4	2.4	2.5	2.5	2.5	2.6	2.7	2.6	2.7	2.8	2.9	2.8	2.9	3.0	3.1	2.9	3.0	3.1	3.2	3.1	3.2	3.3	3.4
	Hi PR	151	162	171	178	169	182	192	200	192	207	218	228	219	235	249	259	246	265	280	292	272	293	309	322
	Lo PR	63	67	73	77	66	70	77	82	69	73	80	85	72	77	84	89	76	81	88	94	78	83	91	97
	MBh	40.2	41.4	44.8	48.1	39.3	40.4	43.7	46.9	38.3	39.5	42.7	45.8	37.4	38.49	41.7	44.7	35.5	36.6	39.6	42.5	32.9	33.9	36.7	39.3
	S/T	0.79	0.70	0.53	0.34	0.82	0.73	0.55	0.36	0.84	0.75	0.57	0.36	0.86	0.77	0.58	0.38	0.90	0.80	0.61	0.39	0.90	0.81	0.61	0.39
	ΔT	21	19	16	11	21	19	16	11	21	19	16	11	21	20	16	11	21	19	16	11	20	18	15	10
	kW	2.94	3.01	3.12	3.23	3.20	3.28	3.40	3.52	3.43	3.51	3.64	3.78	3.63	3.72	3.86	4.00	3.80	3.90	4.04	4.19	3.95	4.05	4.20	4.35
	Amps	2.3	2.3	2.4	2.4	2.4	2.5	2.5	2.6	2.6	2.6	2.7	2.8	2.7	2.8	2.9	3.0	2.9	2.9	3.0	3.1	3.0	3.1	3.2	3.3
	Hi PR	146	157	166	173	164	176	186	194	186	201	212	221	212	228	241	252	239	257	271	283	264	284	300	313
Lo PR	61	65	71	75	64	68	75	79	67	71	78	83	70	75	81	87	73	78	85	91	76	81	88	94	

IDB: Entering Indoor Dry Bulb Temperature kW = Total system power Shaded area reflects ACCA (TVA) conditions Amps = outdoor unit amps (comp.+fan)
 High and low pressures are measured at the liquid and suction service valves. Design Subcooling 9 ±3 °F @ the liquid service valve, ARI 95 test conditions

EXPANDED COOLING DATA — GSH130484A* / ARUF61-00*-1* / ARUF48601A* (CONT.)

IDB	Airflow	Outdoor Ambient Temperature																								
		65°F				75°F				85°F				95°F				105°F				115°F				
		Entering Indoor Wet Bulb Temperature																								
		59	63	67	71	59	63	67	71	59	63	67	71	59	63	67	71	59	63	67	71	59	63	67	71	
80	1800	MBh	45.64	46.84	49.83	53.26	44.58	45.55	48.67	52.03	43.52	44.47	47.51	50.79	42.46	43.38	46.35	49.55	40.33	41.21	44.03	47.07	37.36	38.18	40.79	43.60
		S/T	0.94	0.88	0.72	0.54	1.00	0.91	0.74	0.56	1.00	0.94	0.76	0.57	1.00	0.97	0.79	0.59	1.00	1.00	0.82	0.61	1.00	1.00	0.82	0.62
		ΔT	22	21	18	15	23	21	18	15	22	21	18	15	22	21	19	15	21	21	18	15	19	19	17	14
	kW	3.08	3.15	3.27	3.39	3.35	3.43	3.56	3.69	3.59	3.68	3.82	3.96	3.80	3.90	4.04	4.19	3.98	4.08	4.23	4.39	4.14	4.24	4.40	4.57	
	Amps	2.3	2.4	2.5	2.5	2.5	2.6	2.7	2.8	2.7	2.7	2.8	2.9	2.8	2.9	3.0	3.1	3.0	3.1	3.2	3.3	3.1	3.2	3.3	3.4	
	Hi-PR	154	165	175	182	172	185	196	204	196	211	223	232	223	240	254	265	251	270	285	298	277	299	315	329	
	Lo-PR	64	68	74	79	68	72	78	84	70	75	82	87	74	78	86	91	77	82	90	96	80	85	93	99	
	MBh	44.3	45.3	48.4	51.7	43.3	44.2	47.3	50.5	42.3	43.2	46.1	49.3	41.2	42.1	45.0	48.1	39.2	40.0	42.8	45.7	36.3	37.1	39.6	42.3	
	S/T	0.90	0.84	0.68	0.51	0.93	0.87	0.71	0.53	0.95	0.89	0.73	0.54	0.98	0.92	0.75	0.56	1.00	0.96	0.78	0.58	1.00	0.96	0.78	0.59	
	ΔT	23	22	19	15	23	22	19	15	23	22	19	15	23	22	19	15	23	22	19	15	21	21	18	14	
	kW	3.05	3.12	3.24	3.36	3.32	3.40	3.53	3.66	3.56	3.65	3.78	3.92	3.77	3.86	4.00	4.15	3.95	4.05	4.20	4.35	4.10	4.20	4.36	4.52	
	Amps	2.3	2.4	2.4	2.5	2.5	2.5	2.6	2.7	2.7	2.7	2.8	2.9	2.8	2.9	3.0	3.1	3.0	3.0	3.1	3.2	3.1	3.2	3.3	3.4	
	Hi-PR	152	164	173	180	171	184	194	202	194	209	220	230	221	238	251	262	249	268	283	295	275	296	312	326	
Lo-PR	63	67	73	78	67	71	78	83	69	74	81	86	73	78	85	90	76	81	89	95	79	84	92	98		
MBh	40.9	41.8	44.7	47.7	39.9	40.8	43.6	46.6	39.0	39.8	42.6	45.5	38.0	38.9	41.5	44.4	36.1	36.9	39.5	42.2	33.5	34.2	36.6	39.1		
S/T	0.86	0.81	0.66	0.49	0.90	0.84	0.68	0.51	0.92	0.86	0.70	0.52	0.95	0.89	0.72	0.54	0.98	0.92	0.75	0.56	0.99	0.93	0.76	0.57		
ΔT	23	22	19	15	23	23	20	16	24	23	20	16	24	23	20	16	23	22	19	16	22	21	18	15		
kW	2.97	3.04	3.15	3.26	3.23	3.31	3.43	3.55	3.46	3.54	3.67	3.81	3.66	3.75	3.89	4.04	3.84	3.93	4.08	4.23	3.99	4.09	4.24	4.40		
Amps	2.3	2.3	2.4	2.5	2.4	2.5	2.5	2.6	2.6	2.7	2.7	2.8	2.7	2.8	2.9	3.0	2.9	3.0	3.0	3.1	3.0	3.1	3.2	3.3		
Hi-PR	147	159	168	175	165	178	188	196	188	203	214	223	214	231	244	254	241	260	274	286	266	287	303	316		
Lo-PR	61	65	71	76	65	69	75	80	67	72	78	83	71	75	82	88	74	79	86	92	77	82	89	95		
85	1800	MBh	46.44	47.34	49.58	52.89	45.36	46.24	48.42	51.66	44.28	45.14	47.27	50.43	43.20	44.03	46.12	49.20	41.04	41.83	43.81	46.74	38.01	38.75	40.58	43.30
		S/T	0.98	0.95	0.86	0.70	1.00	0.98	0.89	0.72	1.00	1.00	0.91	0.74	1.00	1.00	0.94	0.76	1.00	1.00	0.98	0.79	1.00	1.00	0.98	0.80
		ΔT	23	23	22	19	23	23	22	19	22	22	22	19	22	22	22	19	21	21	22	19	19	20	20	18
	kW	3.11	3.18	3.30	3.42	3.38	3.46	3.59	3.72	3.62	3.71	3.85	3.99	3.84	3.93	4.08	4.23	4.02	4.12	4.27	4.44	4.18	4.28	4.44	4.61	
	Amps	2.4	2.4	2.5	2.6	2.5	2.6	2.6	2.7	2.7	2.8	2.8	2.9	2.9	2.9	3.0	3.1	3.0	3.1	3.2	3.3	3.2	3.2	3.3	3.5	
	Hi-PR	155	167	176	184	174	187	198	206	198	213	225	235	225	243	256	267	254	273	288	301	280	302	318	332	
	Lo-PR	65	69	75	80	68	73	79	84	71	75	82	88	74	79	86	92	78	83	91	97	81	86	94	100	
	MBh	45.1	46.0	48.1	51.4	44.0	44.9	47.0	50.2	43.0	43.8	45.9	49.0	41.9	42.8	44.8	47.8	39.8	40.6	42.5	45.4	36.9	37.6	39.4	42.0	
	S/T	0.94	0.91	0.82	0.66	0.97	0.94	0.85	0.69	1.00	0.96	0.87	0.71	1.00	0.99	0.90	0.73	1.00	1.00	0.93	0.76	1.00	1.00	0.94	0.76	
	ΔT	24	24	23	20	25	24	23	20	25	24	23	20	24	24	23	20	23	23	23	20	21	22	21	18	
	kW	3.08	3.15	3.27	3.39	3.35	3.43	3.56	3.69	3.59	3.68	3.82	3.96	3.80	3.90	4.04	4.19	3.98	4.08	4.23	4.39	4.14	4.24	4.40	4.57	
	Amps	2.3	2.4	2.5	2.5	2.5	2.6	2.6	2.7	2.7	2.7	2.8	2.9	2.8	2.9	3.0	3.1	3.0	3.1	3.1	3.3	3.1	3.2	3.3	3.4	
	Hi-PR	154	165	175	182	172	185	196	204	196	211	223	232	223	240	254	265	251	270	285	298	277	299	315	329	
Lo-PR	64	68	74	79	68	72	78	84	70	75	82	87	74	78	86	91	77	82	90	96	80	85	93	99		
MBh	41.6	42.4	44.4	47.4	40.6	41.4	43.4	46.3	39.7	40.4	42.4	45.2	38.7	39.5	41.3	44.1	36.8	37.5	39.3	41.9	34.1	34.7	36.4	38.8		
S/T	0.91	0.87	0.79	0.64	0.94	0.91	0.82	0.66	0.96	0.93	0.84	0.68	0.99	0.96	0.86	0.70	1.00	0.99	0.90	0.73	1.00	1.00	0.91	0.73		
ΔT	25	24	23	20	25	25	23	20	25	25	23	20	25	25	23	20	24	24	23	20	22	23	22	19		
kW	2.99	3.07	3.18	3.29	3.26	3.34	3.46	3.59	3.49	3.58	3.71	3.85	3.70	3.79	3.93	4.08	3.87	3.97	4.12	4.27	4.02	4.12	4.28	4.44		
Amps	2.3	2.3	2.4	2.5	2.4	2.5	2.6	2.6	2.6	2.6	2.7	2.8	2.8	2.8	2.9	3.0	2.9	3.0	3.1	3.2	3.1	3.1	3.2	3.3		
Hi-PR	149	160	169	177	167	180	190	198	190	205	216	225	217	233	246	257	244	262	277	289	269	290	306	319		
Lo-PR	62	66	72	77	66	70	76	81	68	72	79	84	72	76	83	88	75	80	87	93	78	82	89	96		

IDB: Entering Indoor Dry Bulb Temperature kW = Total system power Shaded area reflects ARI Rating conditions Amps = outdoor unit amps (comp.+fan)
 High and low pressures are measured at the liquid and suction service valves. Design Subcooling 9 ±3 °F @ the liquid service valve, ARI 95 test conditions

EXPANDED COOLING DATA — GSH130601A* / ARUF61-00*-1* / ARUF48601A*

IDB		Outdoor Ambient Temperature																													
		65°F					75°F					85°F					95°F					105°F					115°F				
		Entering Indoor Wet Bulb Temperature																													
2025	Airflow	59	63	67	71	59	63	67	71	59	63	67	71	59	63	67	71	59	63	67	71										
	MBh	54.4	56.4	61.8	-	53.1	55.1	60.3	-	51.9	53.7	58.9	-	50.6	52.4	57.5	-	48.1	49.8	54.6	-	44.5	46.1	50.6	-						
	S/T	0.72	0.60	0.42	-	0.75	0.63	0.43	-	0.77	0.64	0.45	-	0.79	0.66	0.46	-	0.82	0.69	0.48	-	0.83	0.69	0.48	-						
	ΔT	18	15	12	-	18	16	12	-	18	16	12	-	18	16	12	-	18	16	12	-	17	15	11	-						
	kW	3.84	3.92	4.03	-	4.12	4.20	4.32	-	4.36	4.45	4.58	-	4.57	4.67	4.81	-	4.75	4.85	5.00	-	4.91	5.01	5.17	-						
	Amps	13.8	14.1	14.6	-	14.9	15.2	15.7	-	16.2	16.6	17.1	-	17.3	17.7	18.3	-	18.4	18.8	19.5	-	19.5	20.0	20.6	-						
	Hi PR	140	151	159	-	157	169	179	-	179	193	204	-	204	220	232	-	229	247	261	-	254	273	288	-						
	Lo PR	59	63	68	-	62	66	72	-	65	69	75	-	68	72	79	-	71	76	82	-	73	78	85	-						
	MBh	52.8	54.7	60.0	-	51.6	53.5	58.6	-	50.3	52.2	57.2	-	49.1	50.9	55.8	-	46.7	48.4	53.0	-	43.2	44.8	49.1	-						
	S/T	0.69	0.58	0.40	-	0.72	0.60	0.41	-	0.73	0.61	0.42	-	0.76	0.63	0.44	-	0.79	0.66	0.45	-	0.79	0.66	0.46	-						
	ΔT	19	16	12	-	19	16	12	-	19	16	12	-	19	16	12	-	19	16	12	-	17	15	11	-						
	kW	3.81	3.89	4.00	-	4.09	4.17	4.29	-	4.32	4.41	4.55	-	4.54	4.63	4.77	-	4.72	4.81	4.96	-	4.87	4.97	5.13	-						
Amps	13.7	14.0	14.4	-	14.8	15.1	15.6	-	16.0	16.4	17.0	-	17.1	17.5	18.1	-	18.2	18.7	19.3	-	19.3	19.8	20.5	-							
Hi PR	139	150	158	-	156	168	177	-	177	191	202	-	202	217	230	-	227	245	258	-	251	270	285	-							
Lo PR	58	62	68	-	61	65	71	-	64	68	74	-	67	71	78	-	70	75	82	-	73	77	84	-							
MBh	48.7	50.5	55.3	-	47.6	49.3	54.1	-	46.5	48.2	52.8	-	45.3	47.0	51.5	-	43.1	44.6	48.9	-	39.9	41.4	45.3	-							
S/T	0.67	0.56	0.39	-	0.69	0.58	0.40	-	0.71	0.59	0.41	-	0.73	0.61	0.42	-	0.76	0.63	0.44	-	0.76	0.64	0.44	-							
ΔT	19	16	12	-	19	17	13	-	19	17	13	-	19	17	13	-	19	16	13	-	18	15	12	-							
kW	3.73	3.80	3.91	-	3.99	4.07	4.19	-	4.23	4.31	4.44	-	4.43	4.52	4.66	-	4.60	4.70	4.85	-	4.75	4.85	5.01	-							
Amps	13.3	13.6	14.0	-	14.4	14.7	15.2	-	15.6	16.0	16.5	-	16.7	17.1	17.6	-	17.7	18.2	18.8	-	18.8	19.2	19.9	-							
Hi PR	135	145	153	-	151	163	172	-	172	185	195	-	196	211	223	-	220	237	250	-	244	262	277	-							
Lo PR	56	60	66	-	60	63	69	-	62	66	72	-	65	69	76	-	68	73	79	-	71	75	82	-							

2025	Airflow	59	63	67	71	59	63	67	71	59	63	67	71	59	63	67	71	59	63	67	71					
	MBh	55.31	56.94	61.64	66.15	54.02	55.62	60.20	64.61	52.73	54.30	58.77	63.08	51.45	52.97	57.34	61.54	48.88	50.32	54.47	58.46	45.27	46.61	50.46	54.15	
	S/T	0.82	0.74	0.56	0.36	0.85	0.76	0.58	0.37	0.87	0.78	0.59	0.38	0.90	0.81	0.61	0.39	0.94	0.84	0.63	0.41	0.94	0.84	0.64	0.41	
	ΔT	21	19	16	11	21	19	16	11	21	19	16	11	21	19	16	11	21	19	16	11	21	19	15	10	
	kW	3.87	3.95	4.06	4.18	4.15	4.23	4.36	4.49	4.39	4.48	4.62	4.76	4.61	4.70	4.85	5.00	4.79	4.89	5.04	5.21	4.95	5.05	5.21	5.38	
	Amps	13.9	14.2	14.7	15.2	15.0	15.4	15.9	16.5	16.3	16.7	17.3	17.9	17.4	17.9	18.5	19.2	18.6	19.0	19.7	20.4	19.7	20.2	20.8	21.6	
	Hi PR	142	153	161	168	159	171	181	189	181	195	206	214	206	222	234	244	232	249	263	275	256	276	291	304	
	Lo PR	59	63	69	73	63	67	73	78	81	65	69	76	81	68	73	80	85	72	76	83	89	74	79	86	92
	MBh	53.7	55.3	59.8	64.2	52.4	54.0	58.4	62.7	51.2	52.7	57.1	61.2	50.0	51.4	55.7	59.7	47.5	48.9	52.9	56.8	44.0	45.3	49.0	52.6	
	S/T	0.78	0.70	0.53	0.34	0.81	0.73	0.55	0.35	0.83	0.75	0.56	0.36	0.86	0.77	0.58	0.37	0.89	0.80	0.60	0.39	0.90	0.81	0.61	0.39	
	ΔT	22	20	16	11	22	20	16	11	22	20	16	11	22	20	17	11	22	20	16	11	22	20	19	15	11
	kW	3.84	3.92	4.03	4.15	4.12	4.20	4.32	4.46	4.36	4.45	4.58	4.73	4.57	4.67	4.81	4.96	4.75	4.85	5.00	5.16	4.91	5.01	5.17	5.34	
Amps	13.8	14.1	14.6	15.1	14.9	15.2	15.7	16.3	16.2	16.6	17.1	17.8	17.3	17.7	18.3	19.0	18.4	18.8	19.5	20.2	19.5	20.0	20.6	21.4		
Hi PR	140	151	160	166	158	170	179	187	179	193	204	212	204	220	232	242	230	247	261	272	254	273	288	301		
Lo PR	59	63	68	73	62	66	72	77	65	69	75	80	68	72	79	84	71	76	82	88	73	78	85	91		
MBh	49.6	51.0	55.2	59.3	48.4	49.8	53.9	57.9	47.3	48.7	52.7	56.5	46.1	47.47	51.4	55.1	43.8	45.1	48.8	52.4	40.6	41.8	45.2	48.5		
S/T	0.76	0.68	0.51	0.33	0.78	0.70	0.53	0.34	0.80	0.72	0.54	0.35	0.83	0.74	0.56	0.36	0.86	0.77	0.58	0.38	0.87	0.78	0.59	0.38		
ΔT	22	20	17	11	22	20	17	12	22	20	17	12	22	21	17	12	22	20	17	12	22	20	17	11	11	
kW	3.76	3.83	3.94	4.06	4.02	4.10	4.23	4.35	4.26	4.34	4.48	4.61	4.46	4.56	4.70	4.84	4.64	4.74	4.88	5.04	4.79	4.89	5.05	5.21		
Amps	13.4	13.7	14.2	14.7	14.5	14.8	15.3	15.9	15.7	16.1	16.6	17.3	16.8	17.2	17.8	18.5	17.9	18.3	18.9	19.7	19.0	19.4	20.1	20.8		
Hi PR	136	147	155	161	153	164	174	181	174	187	197	206	198	213	225	235	223	240	253	264	246	265	280	292		
Lo PR	57	61	66	71	60	64	70	74	63	67	73	77	66	70	76	81	69	73	80	85	71	76	83	88		

IDB: Entering Indoor Dry Bulb Temperature kW = Total system power Shaded area reflects ACCA (TVA) conditions Amps = outdoor unit amps (comp.+fan)
High and low pressures are measured at the liquid and suction service valves. Design Subcooling 9 ±3 °F @ the liquid service valve, ARI 95 test conditions

EXPANDED COOLING DATA — GSH130601A* / ARUF61-00*-1* / ARUF48601A* (CONT.)

IDB	Airflow	Outdoor Ambient Temperature																							
		65°F			75°F			85°F			95°F			105°F			115°F								
		59	63	67	71	59	63	67	71	59	63	67	71	59	63	67	71	59	63	67	71				
2025	MBh	56.3	57.5	61.5	65.7	55.0	56.2	60.0	64.2	53.7	54.8	58.6	62.6	52.4	53.5	57.2	61.1	49.7	50.8	54.3	58.1	46.1	47.1	50.3	53.8
	S/T	0.90	0.85	0.69	0.51	0.94	0.88	0.71	0.53	0.96	0.90	0.73	0.55	1.00	0.93	0.76	0.56	1.00	0.96	0.78	0.59	1.00	1.00	0.79	0.59
	ΔT	23	22	19	15	23	22	19	16	23	22	19	16	24	23	20	16	23	22	19	15	21	21	18	14
	kW	3.90	3.98	4.09	4.22	4.18	4.26	4.39	4.53	4.43	4.52	4.66	4.80	4.64	4.74	4.89	5.04	4.83	4.93	5.09	5.25	4.99	5.09	5.26	5.43
	Amps	14.0	14.4	14.8	15.4	15.2	15.5	16.0	16.6	16.5	16.9	17.4	18.1	17.6	18.0	18.6	19.3	18.7	19.2	19.8	20.6	19.9	20.3	21.0	21.8
Hi PR	143	154	163	170	161	173	183	190	183	197	208	217	208	224	237	247	234	252	266	278	259	278	294	307	
Lo PR	60	64	70	74	63	67	74	78	66	70	76	81	69	74	80	86	72	77	84	90	75	80	87	93	
80	MBh	54.7	55.8	59.7	63.8	53.4	54.5	58.3	62.3	52.1	53.2	56.9	60.8	50.8	51.9	55.5	59.3	48.3	49.4	52.7	56.4	44.7	45.7	48.8	52.2
	S/T	0.86	0.81	0.66	0.49	0.89	0.84	0.68	0.51	0.91	0.86	0.70	0.52	0.94	0.89	0.72	0.54	0.98	0.92	0.75	0.56	0.99	0.93	0.75	0.56
	ΔT	24	23	20	16	24	23	20	16	24	23	20	16	25	23	20	16	24	23	20	16	23	22	19	15
	kW	3.87	3.95	4.06	4.19	4.15	4.23	4.36	4.49	4.39	4.48	4.62	4.76	4.61	4.70	4.85	5.00	4.79	4.89	5.04	5.21	4.95	5.05	5.21	5.38
	Amps	13.9	14.2	14.7	15.2	15.0	15.4	15.9	16.5	16.3	16.7	17.3	17.9	17.4	17.9	18.5	19.2	18.6	19.0	19.7	20.4	19.7	20.2	20.8	21.6
Hi PR	142	153	161	168	159	171	181	189	181	195	206	214	206	222	234	244	232	250	263	275	256	276	291	304	
Lo PR	59	63	69	73	63	67	73	78	65	69	76	81	68	73	80	85	72	76	83	89	74	79	86	92	
1575	MBh	50.4	51.5	55.1	58.9	49.3	50.3	53.8	57.5	48.1	49.1	52.5	56.1	46.9	47.9	51.2	54.8	44.6	45.6	48.7	52.0	41.3	42.2	45.1	48.2
	S/T	0.83	0.78	0.63	0.47	0.86	0.81	0.66	0.49	0.88	0.83	0.67	0.50	0.91	0.85	0.69	0.52	0.94	0.89	0.72	0.54	0.95	0.89	0.73	0.54
	ΔT	24	23	20	16	25	24	21	16	25	24	21	16	25	24	21	17	25	24	20	16	23	22	19	15
	kW	3.79	3.86	3.97	4.09	4.05	4.13	4.26	4.39	4.29	4.38	4.51	4.65	4.50	4.59	4.73	4.88	4.68	4.78	4.92	5.08	4.83	4.93	5.09	5.25
	Amps	13.5	13.8	14.3	14.8	14.6	15.0	15.5	16.0	15.9	16.3	16.8	17.4	17.0	17.4	18.0	18.6	18.1	18.5	19.1	19.8	19.1	19.6	20.3	21.0
Hi PR	138	148	156	163	154	166	175	183	176	189	199	208	200	215	227	237	225	242	256	267	248	267	282	295	
Lo PR	58	61	67	71	61	65	71	75	63	67	73	78	66	71	77	82	70	74	81	86	72	77	84	89	
85	MBh	57.3	58.4	61.1	65.2	55.9	57.0	59.7	63.7	54.6	55.7	58.3	62.2	53.3	54.3	56.9	60.7	50.6	51.6	54.0	57.6	46.9	47.8	50.1	53.4
	S/T	0.95	0.91	0.82	0.67	0.98	0.95	0.85	0.69	1.00	0.97	0.88	0.71	1.00	1.00	0.90	0.73	1.00	1.00	0.94	0.76	1.00	1.00	0.95	0.77
	ΔT	25	24	23	20	25	24	23	20	25	25	23	20	24	25	23	20	23	23	23	20	21	22	21	19
	kW	3.93	4.01	4.12	4.25	4.21	4.30	4.43	4.56	4.46	4.55	4.69	4.84	4.68	4.78	4.93	5.08	4.87	4.97	5.13	5.29	5.03	5.14	5.30	5.47
	Amps	14.2	14.5	15.0	15.5	15.3	15.7	16.2	16.8	16.6	17.0	17.6	18.3	17.8	18.2	18.8	19.5	18.9	19.4	20.0	20.8	20.0	20.5	21.2	22.0
Hi PR	145	156	164	171	162	175	184	192	185	199	210	219	210	226	239	249	237	255	269	280	261	281	297	310	
Lo PR	61	64	70	75	64	68	74	79	66	71	77	82	70	74	81	86	73	78	85	91	76	81	88	94	
MBh	55.6	56.7	59.4	63.3	54.3	55.4	58.0	61.9	53.0	54.0	56.6	60.4	51.7	52.7	55.2	58.9	49.1	50.1	52.5	56.0	45.5	46.4	48.6	51.8	
S/T	0.90	0.87	0.79	0.64	0.94	0.90	0.81	0.66	0.96	0.93	0.84	0.68	0.99	0.96	0.86	0.70	1.00	0.99	0.89	0.73	1.00	1.00	0.90	0.73	
ΔT	26	25	24	21	26	26	24	21	26	26	24	21	26	26	24	21	25	25	24	21	23	24	22	19	
kW	3.90	3.98	4.09	4.22	4.18	4.26	4.39	4.53	4.43	4.52	4.66	4.80	4.64	4.74	4.89	5.04	4.83	4.93	5.09	5.25	4.99	5.09	5.26	5.43	
Amps	14.0	14.4	14.8	15.4	15.2	15.5	16.0	16.6	16.5	16.9	17.4	18.1	17.6	18.0	18.6	19.3	18.7	19.2	19.8	20.6	19.9	20.3	21.0	21.8	
Hi PR	143	154	163	170	161	173	183	190	183	197	208	217	208	224	237	247	234	252	266	278	259	278	294	307	
Lo PR	60	64	70	74	63	67	74	78	66	70	76	81	69	74	80	86	72	77	84	90	75	80	87	93	
MBh	51.3	52.3	54.8	58.5	50.1	51.1	53.5	57.1	48.9	49.9	52.2	55.7	47.7	48.7	51.0	54.4	45.4	46.2	48.4	51.7	42.0	42.8	44.9	47.9	
S/T	0.87	0.84	0.76	0.61	0.90	0.87	0.79	0.64	0.92	0.89	0.81	0.65	0.95	0.92	0.83	0.67	0.99	0.96	0.86	0.70	1.00	0.96	0.87	0.71	
ΔT	26	26	24	21	26	26	25	21	26	26	25	21	27	26	25	21	26	26	24	21	24	24	23	20	
kW	3.81	3.89	4.00	4.12	4.08	4.17	4.29	4.42	4.32	4.41	4.55	4.69	4.53	4.63	4.77	4.92	4.71	4.81	4.96	5.12	4.87	4.97	5.13	5.29	
Amps	13.6	14.0	14.4	15.0	14.7	15.1	15.6	16.2	16.0	16.4	17.0	17.6	17.1	17.5	18.1	18.8	18.2	18.7	19.3	20.0	19.3	19.8	20.4	21.2	
Hi PR	139	149	158	165	156	168	177	185	177	191	201	210	202	217	229	239	227	244	258	269	251	270	285	297	
Lo PR	58	62	68	72	61	65	71	76	64	68	74	79	67	71	78	83	70	75	82	87	73	77	84	90	

IDB: Entering Indoor Dry Bulb Temperature kW = Total system power Shaded area reflects ARI Rating conditions Amps = outdoor unit amps (comp.+fan)
 High and low pressures are measured at the liquid and suction service valves. Design Subcooling 9 ±3 °F @ the liquid service valve, ARI 95 test conditions

EXPANDED COOLING DATA — GSH130603A* / ARUF61-00*-1* / ARUF48601A*

IDB	Airflow	Outdoor Ambient Temperature																								
		65°F				75°F				85°F				95°F				105°F				115°F				
		59	63	67	71	59	63	67	71	59	63	67	71	59	63	67	71	59	63	67	71	59	63	67	71	
2025	MBh	54.4	56.4	61.8	-	53.1	55.1	60.3	-	51.9	53.7	58.9	-	50.6	52.4	57.5	-	48.1	49.8	54.6	-	44.5	46.1	50.6	-	
	S/T	0.72	0.60	0.42	-	0.75	0.63	0.43	-	0.77	0.64	0.45	-	0.79	0.66	0.46	-	0.82	0.69	0.48	-	0.83	0.69	0.48	-	
	ΔT	18	15	12	-	18	16	12	-	18	16	12	-	18	16	12	-	18	16	12	-	17	15	11	-	
	kW	4.03	4.12	4.25	-	4.35	4.45	4.60	-	4.64	4.74	4.90	-	4.89	5.00	5.17	-	5.10	5.22	5.39	-	5.28	5.40	5.59	-	
	Amps	13.0	13.3	13.8	-	14.1	14.4	14.9	-	15.3	15.7	16.2	-	16.3	16.7	17.3	-	17.4	17.8	18.4	-	18.4	18.9	19.5	-	
	Hi PR	146	157	166	-	164	176	186	-	186	200	211	-	212	228	241	-	238	257	271	-	263	283	299	-	
	Lo PR	57	61	66	-	60	64	70	-	63	67	73	-	66	70	76	-	69	73	80	-	71	76	83	-	
	70	MBh	52.8	54.7	60.0	-	51.6	53.5	58.6	-	50.3	52.2	57.2	-	49.1	50.9	55.8	-	46.7	48.4	53.0	-	43.2	44.8	49.1	-
		S/T	0.69	0.58	0.40	-	0.72	0.60	0.41	-	0.73	0.61	0.42	-	0.76	0.63	0.44	-	0.79	0.66	0.45	-	0.79	0.66	0.46	-
		ΔT	19	16	12	-	19	16	12	-	19	16	12	-	19	16	12	-	19	16	12	-	17	15	11	-
kW		4.00	4.09	4.22	-	4.32	4.41	4.56	-	4.60	4.70	4.86	-	4.84	4.96	5.12	-	5.06	5.17	5.35	-	5.24	5.36	5.54	-	
Amps		12.9	13.2	13.7	-	14.0	14.3	14.8	-	15.1	15.5	16.0	-	16.2	16.6	17.1	-	17.2	17.6	18.2	-	18.2	18.7	19.3	-	
Hi PR		144	155	164	-	162	174	184	-	184	198	209	-	210	226	238	-	236	254	268	-	261	281	296	-	
Lo PR		57	60	66	-	60	64	69	-	62	66	72	-	65	69	76	-	68	73	79	-	71	75	82	-	
1575		MBh	48.7	50.5	55.3	-	47.6	49.3	54.1	-	46.5	48.2	52.8	-	45.3	47.0	51.5	-	43.1	44.6	48.9	-	39.9	41.4	45.3	-
		S/T	0.67	0.56	0.39	-	0.69	0.58	0.40	-	0.71	0.59	0.41	-	0.73	0.61	0.42	-	0.76	0.63	0.44	-	0.76	0.64	0.44	-
		ΔT	19	16	12	-	19	17	13	-	19	17	13	-	19	17	13	-	19	16	13	-	18	15	12	-
	kW	3.90	3.99	4.12	-	4.21	4.30	4.44	-	4.48	4.58	4.73	-	4.72	4.83	4.99	-	4.93	5.04	5.21	-	5.10	5.22	5.40	-	
	Amps	12.6	12.9	13.3	-	13.6	13.9	14.4	-	14.7	15.1	15.6	-	15.7	16.1	16.7	-	16.7	17.1	17.7	-	17.7	18.2	18.8	-	
	Hi PR	140	151	159	-	157	169	179	-	179	192	203	-	204	219	231	-	229	246	260	-	253	272	287	-	
	Lo PR	55	58	64	-	58	62	67	-	60	64	70	-	63	67	73	-	66	70	77	-	69	73	80	-	

IDB	Airflow	Outdoor Ambient Temperature																								
		65°F				75°F				85°F				95°F				105°F				115°F				
		59	63	67	71	59	63	67	71	59	63	67	71	59	63	67	71	59	63	67	71	59	63	67	71	
2025	MBh	55.31	56.94	61.64	66.15	54.02	55.62	60.20	64.61	52.73	54.30	58.77	63.08	51.45	52.97	57.34	61.54	48.88	50.32	54.47	58.46	45.27	46.61	50.46	54.15	
	S/T	0.82	0.74	0.56	0.36	0.85	0.76	0.58	0.37	0.87	0.78	0.59	0.38	0.90	0.81	0.61	0.39	0.94	0.84	0.63	0.41	0.94	0.84	0.64	0.41	
	ΔT	21	19	16	11	21	19	16	11	21	19	16	11	21	19	16	11	21	19	16	11	21	19	15	10	
	kW	4.07	4.16	4.29	4.43	4.39	4.49	4.64	4.79	4.68	4.78	4.94	5.11	4.93	5.04	5.21	5.39	5.14	5.26	5.44	5.63	5.33	5.45	5.64	5.83	
	Amps	13.2	13.5	13.9	14.4	14.2	14.5	15.0	15.6	15.4	15.8	16.3	16.9	16.5	16.9	17.4	18.1	17.5	18.0	18.6	19.3	18.6	19.0	19.7	20.4	
	Hi PR	147	159	167	175	165	178	188	196	188	202	214	223	214	230	243	254	241	259	274	285	266	286	302	315	
	Lo PR	58	61	67	71	61	65	71	75	63	67	74	78	67	71	77	82	70	74	81	86	72	77	84	89	
	75	MBh	53.7	55.3	59.8	64.2	52.4	54.0	58.4	62.7	51.2	52.7	57.1	61.2	50.0	51.4	55.7	59.7	47.5	48.9	52.9	56.8	44.0	45.3	49.0	52.6
		S/T	0.78	0.70	0.53	0.34	0.81	0.73	0.55	0.35	0.83	0.75	0.56	0.36	0.86	0.77	0.58	0.37	0.89	0.80	0.60	0.39	0.90	0.81	0.61	0.39
		ΔT	22	20	16	11	22	20	16	11	22	20	16	11	22	20	17	11	22	20	16	11	20	19	15	11
kW		4.03	4.12	4.26	4.40	4.35	4.45	4.60	4.75	4.64	4.74	4.90	5.07	4.89	5.00	5.17	5.35	5.10	5.22	5.39	5.58	5.28	5.40	5.59	5.78	
Amps		13.0	13.3	13.8	14.3	14.1	14.4	14.9	15.4	15.3	15.7	16.2	16.8	16.3	16.7	17.3	17.9	17.4	17.8	18.4	19.1	18.4	18.9	19.5	20.2	
Hi PR		146	157	166	173	164	176	186	194	186	200	211	221	212	228	241	251	238	257	271	283	263	284	299	312	
Lo PR		57	61	66	71	60	64	70	75	63	67	73	78	66	70	76	81	69	73	80	85	71	76	83	88	
1575		MBh	49.6	51.0	55.2	59.3	48.4	49.8	53.9	57.9	47.3	48.7	52.7	56.5	46.1	47.47	51.4	55.1	43.8	45.1	48.8	52.4	40.6	41.8	45.2	48.5
		S/T	0.76	0.68	0.51	0.33	0.78	0.70	0.53	0.34	0.80	0.72	0.54	0.35	0.83	0.74	0.56	0.36	0.86	0.77	0.58	0.38	0.87	0.78	0.59	0.38
		ΔT	22	20	17	11	22	20	17	12	22	20	17	12	22	21	17	12	22	20	17	11	21	19	16	11
	kW	3.93	4.02	4.15	4.29	4.24	4.34	4.48	4.63	4.52	4.62	4.78	4.94	4.76	4.87	5.03	5.21	4.97	5.08	5.25	5.44	5.15	5.26	5.44	5.63	
	Amps	12.7	13.0	13.4	13.9	13.7	14.0	14.5	15.0	14.9	15.2	15.7	16.3	15.9	16.3	16.8	17.4	16.9	17.3	17.9	18.6	17.9	18.3	18.9	19.7	
	Hi PR	141	152	161	168	159	171	180	188	181	194	205	214	206	221	234	244	231	249	263	274	256	275	290	303	
	Lo PR	55	59	64	68	59	62	68	72	61	65	71	75	64	68	74	79	67	71	78	83	69	74	80	86	

IDB: Entering Indoor Dry Bulb Temperature kW = Total system power Shaded area reflects ACCA (TVA) conditions Amps = outdoor unit amps (comp.+fan)
 High and low pressures are measured at the liquid and suction service valves. Design Subcooling 9 ±3 °F @ the liquid service valve, ARI 95 test conditions

EXPANDED COOLING DATA — GSH130603A* / ARUF61-00*-1* / ARUF48601A* (CONT.)

IDB	Airflow	Outdoor Ambient Temperature																													
		65°F					75°F					85°F					95°F					105°F					115°F				
		59	63	67	71	75	59	63	67	71	75	59	63	67	71	75	59	63	67	71	75	59	63	67	71	75	59	63	67	71	75
	MBh	56.29	57.52	61.45	65.69	54.98	56.18	60.02	64.16	53.67	54.84	58.59	62.64	52.36	53.51	57.17	61.11	49.74	50.83	54.31	58.05	46.08	47.09	50.31	53.78						
	S/T	0.90	0.85	0.69	0.51	0.94	0.88	0.71	0.53	0.96	0.90	0.73	0.55	1.00	0.93	0.76	0.56	1.00	0.96	0.78	0.59	1.00	1.00	0.79	0.59						
	ΔT	23	22	19	15	23	22	19	16	23	22	19	16	24	23	20	16	23	22	19	15	21	21	18	14						
	kW	4.10	4.19	4.33	4.47	4.43	4.53	4.68	4.83	4.72	4.82	4.98	5.16	4.97	5.08	5.26	5.44	5.19	5.31	5.49	5.68	5.38	5.50	5.69	5.89						
	Amps	13.3	13.6	14.0	14.5	14.3	14.7	15.2	15.7	15.6	15.9	16.5	17.1	16.6	17.0	17.6	18.3	17.7	18.1	18.7	19.4	18.8	19.2	19.9	20.6						
	Hi PR	149	160	169	176	167	180	190	198	190	204	216	225	216	233	246	256	243	262	276	288	269	289	305	319						
	Lo PR	58	62	68	72	62	65	71	76	64	68	74	79	67	71	78	83	70	75	82	87	73	77	85	90						
	MBh	54.7	55.8	59.7	63.8	53.4	54.5	58.3	62.3	52.1	53.2	56.9	60.8	50.8	51.9	55.5	59.3	48.3	49.4	52.7	56.4	44.7	45.7	48.8	52.2						
	S/T	0.86	0.81	0.66	0.49	0.89	0.84	0.68	0.51	0.91	0.86	0.70	0.52	0.94	0.89	0.72	0.54	0.98	0.92	0.75	0.56	0.99	0.93	0.75	0.56						
	ΔT	24	23	20	16	24	23	20	16	24	23	20	16	25	23	20	16	24	23	20	16	23	22	19	15						
	kW	4.07	4.16	4.29	4.43	4.39	4.49	4.64	4.79	4.68	4.78	4.94	5.11	4.93	5.04	5.21	5.39	5.14	5.26	5.44	5.63	5.33	5.45	5.64	5.84						
	Amps	13.2	13.5	13.9	14.4	14.2	14.5	15.0	15.6	15.4	15.8	16.3	16.9	16.5	16.9	17.4	18.1	17.5	18.0	18.6	19.3	18.6	19.0	19.7	20.4						
	Hi PR	147	159	167	175	165	178	188	196	188	202	214	223	214	230	243	254	241	259	274	285	266	286	302	315						
	Lo PR	58	61	67	71	61	65	71	75	63	67	74	78	67	71	77	82	70	74	81	86	72	77	84	89						
	MBh	50.4	51.5	55.1	58.9	49.3	50.3	53.8	57.5	48.1	49.1	52.5	56.1	46.9	47.9	51.2	54.8	44.6	45.6	48.7	52.0	41.3	42.2	45.1	48.2						
	S/T	0.83	0.78	0.63	0.47	0.86	0.81	0.66	0.49	0.88	0.83	0.67	0.50	0.91	0.85	0.69	0.52	0.94	0.89	0.72	0.54	0.95	0.89	0.73	0.54						
	ΔT	24	23	20	16	25	24	21	16	25	24	21	16	25	24	21	17	25	24	20	16	23	22	19	15						
	kW	3.97	4.05	4.18	4.32	4.28	4.38	4.52	4.67	4.56	4.66	4.82	4.98	4.80	4.91	5.08	5.25	5.01	5.13	5.30	5.48	5.19	5.31	5.49	5.68						
	Amps	12.8	13.1	13.5	14.0	13.8	14.2	14.6	15.2	15.0	15.4	15.9	16.5	16.0	16.4	17.0	17.6	17.1	17.5	18.1	18.7	18.1	18.5	19.1	19.9						
	Hi PR	143	154	162	169	160	173	182	190	182	196	207	216	208	223	236	246	234	251	266	277	258	278	293	306						
	Lo PR	56	60	65	69	59	63	69	73	61	65	71	76	65	69	75	80	68	72	79	84	70	74	81	87						

	MBh	57.27	58.38	61.15	65.23	55.94	57.02	59.72	63.72	54.61	55.67	58.30	62.20	53.28	54.31	56.88	60.68	50.61	51.59	54.04	57.65	46.88	47.79	50.05	53.40
	S/T	0.95	0.91	0.82	0.67	0.98	0.95	0.85	0.69	1.00	0.97	0.88	0.71	1.00	1.00	0.90	0.73	1.00	1.00	0.94	0.76	1.00	1.00	0.95	0.77
	ΔT	25	24	23	20	25	24	23	20	24	25	23	20	24	25	23	20	23	23	23	20	21	22	21	19
	kW	4.13	4.22	4.36	4.51	4.46	4.56	4.72	4.88	4.76	4.86	5.03	5.20	5.01	5.13	5.30	5.49	5.23	5.35	5.54	5.73	5.42	5.55	5.74	5.94
	Amps	13.4	13.7	14.2	14.7	14.5	14.8	15.3	15.9	15.7	16.1	16.6	17.2	16.8	17.2	17.8	18.4	17.9	18.3	18.9	19.6	18.9	19.4	20.0	20.8
	Hi PR	150	162	171	178	169	181	192	200	192	206	218	227	218	235	248	259	246	264	279	291	271	292	309	322
	Lo PR	59	63	68	73	62	66	72	77	65	69	75	80	68	72	79	84	71	76	83	88	74	78	85	91
	MBh	55.6	56.7	59.4	63.3	54.3	55.4	58.0	61.9	53.0	54.0	56.6	60.4	51.7	52.7	55.2	58.9	49.1	50.1	52.5	56.0	45.5	46.4	48.6	51.8
	S/T	0.90	0.87	0.79	0.64	0.94	0.90	0.81	0.66	0.96	0.93	0.84	0.68	0.99	0.96	0.86	0.70	1.00	0.99	0.89	0.73	1.00	1.00	0.90	0.73
	ΔT	26	25	24	21	26	26	24	21	26	26	24	21	26	26	24	21	25	25	24	21	23	24	22	19
	kW	4.10	4.19	4.33	4.47	4.43	4.53	4.68	4.83	4.72	4.82	4.98	5.16	4.97	5.08	5.26	5.44	5.19	5.31	5.49	5.68	5.38	5.50	5.69	5.89
	Amps	13.3	13.6	14.0	14.5	14.3	14.7	15.2	15.7	15.6	15.9	16.5	17.1	16.6	17.0	17.6	18.3	17.7	18.1	18.7	19.4	18.8	19.2	19.9	20.6
	Hi PR	149	160	169	176	167	180	190	198	190	204	216	225	216	233	246	256	243	262	276	288	269	289	305	319
	Lo PR	58	62	68	72	62	65	71	76	64	68	74	79	67	71	78	83	70	75	82	87	73	77	85	90
	MBh	51.3	52.3	54.8	58.5	50.1	51.1	53.5	57.1	48.9	49.9	52.2	55.7	47.7	48.7	51.0	54.4	45.4	46.2	48.4	51.7	42.0	42.8	44.9	47.9
	S/T	0.87	0.84	0.76	0.61	0.90	0.87	0.79	0.64	0.92	0.89	0.81	0.65	0.95	0.92	0.83	0.67	0.99	0.96	0.86	0.70	1.00	0.96	0.87	0.71
	ΔT	26	26	24	21	26	26	25	21	27	26	25	21	27	26	25	21	26	26	24	21	24	24	23	20
	kW	4.00	4.09	4.22	4.36	4.32	4.41	4.56	4.71	4.60	4.70	4.86	5.02	4.84	4.95	5.12	5.30	5.05	5.17	5.35	5.53	5.24	5.36	5.54	5.73
	Amps	12.9	13.2	13.6	14.1	13.9	14.3	14.7	15.3	15.1	15.5	16.0	16.6	16.2	16.6	17.1	17.8	17.2	17.6	18.2	18.9	18.2	18.7	19.3	20.0
	Hi PR	144	155	164	171	162	174	184	192	184	198	209	218	210	226	238	249	236	254	268	280	261	281	296	309
	Lo PR	56	60	66	70	60	64	69	74	62	66	72	77	65	69	76	81	68	73	79	84	71	75	82	87

IDB: Entering Indoor Dry Bulb Temperature kW = Total system power Shaded area reflects ARI Rating conditions Amps = outdoor unit amps (comp. + fan)
 High and low pressures are measured at the liquid and suction service valves. Design Subcooling 9 ±3 °F @ the liquid service valve, ARI 95 test conditions

EXPANDED COOLING DATA — GSH130604A* / ARUF61-00*-1* / ARUF48601A*

IDB	Airflow	Outdoor Ambient Temperature																								
		65°F				75°F				85°F				95°F				105°F				115°F				
		59	63	67	71	59	63	67	71	59	63	67	71	59	63	67	71	59	63	67	71	59	63	67	71	
70	2025	MBh	54.4	56.4	61.8	-	53.1	55.1	60.3	-	51.9	53.7	58.9	-	50.6	52.4	57.5	-	48.1	49.8	54.6	-	44.5	46.1	50.6	-
		S/T	0.72	0.60	0.42	-	0.75	0.63	0.43	-	0.77	0.64	0.44	-	0.79	0.66	0.46	-	0.82	0.69	0.48	-	0.83	0.69	0.48	-
		ΔT	18	15	12	-	18	16	12	-	18	16	12	-	18	16	12	-	18	16	12	-	17	15	11	-
		KW	3.98	4.06	4.18	-	4.26	4.35	4.48	-	4.52	4.61	4.75	-	4.74	4.84	4.99	-	4.93	5.04	5.19	-	5.09	5.20	5.37	-
		Amps	3.2	3.2	3.3	-	3.3	3.3	3.3	-	3.3	3.3	3.3	-	3.3	3.4	3.4	-	3.4	3.4	3.4	-	3.4	3.4	3.5	-
		Hi/PR	152	163	173	-	170	183	194	-	194	209	220	-	221	238	251	-	248	267	282	-	274	295	312	-
	Lo/PR	59	62	68	-	62	66	72	-	64	68	75	-	68	72	78	-	71	75	82	-	73	78	85	-	
	Lo/PR	58	62	67	-	61	65	71	-	64	68	74	-	67	71	78	-	70	75	81	-	73	77	84	-	
	MBh	48.7	50.5	55.3	-	47.6	49.3	54.1	-	46.5	48.2	52.8	-	45.3	47.0	51.5	-	43.1	44.6	48.9	-	39.9	41.4	45.3	-	
	S/T	0.67	0.56	0.38	-	0.69	0.58	0.40	-	0.71	0.59	0.41	-	0.73	0.61	0.42	-	0.76	0.63	0.44	-	0.76	0.64	0.44	-	
	ΔT	19	16	12	-	19	17	13	-	19	17	13	-	19	17	13	-	19	16	13	-	18	15	12	-	
	KW	3.86	3.94	4.05	-	4.14	4.22	4.34	-	4.38	4.47	4.60	-	4.59	4.69	4.83	-	4.78	4.88	5.03	-	4.93	5.04	5.20	-	
Amps	3.2	3.2	3.2	-	3.2	3.3	3.3	-	3.3	3.3	3.3	-	3.3	3.3	3.4	-	3.4	3.4	3.4	-	3.4	3.4	3.4	-		
Hi/PR	146	157	166	-	164	176	186	-	186	200	211	-	212	228	241	-	238	257	271	-	263	284	299	-		
Lo/PR	56	60	65	-	59	63	69	-	62	66	72	-	65	69	75	-	68	72	79	-	70	75	82	-		

75	2025	MBh	55.31	56.94	61.64	66.15	54.02	55.62	60.20	64.61	52.73	54.30	58.77	63.08	51.45	52.97	57.34	61.54	48.88	50.32	54.47	58.46	45.27	46.61	50.46	54.15	
		S/T	0.82	0.74	0.56	0.36	0.85	0.76	0.58	0.37	0.87	0.78	0.59	0.38	0.90	0.81	0.61	0.39	0.94	0.84	0.63	0.41	0.94	0.84	0.64	0.41	
		ΔT	21	19	16	11	21	19	16	11	21	19	16	11	21	19	16	11	21	19	16	11	21	19	16	11	10
		KW	4.01	4.09	4.21	4.34	4.30	4.38	4.52	4.66	4.55	4.65	4.79	4.94	4.78	4.88	5.03	5.19	4.97	5.08	5.24	5.41	5.14	5.25	5.41	5.59	
		Amps	3.2	3.2	3.3	3.3	3.3	3.3	3.3	3.3	3.3	3.3	3.3	3.4	3.4	3.4	3.4	3.4	3.4	3.4	3.4	3.5	3.4	3.5	3.5	3.5	
		Hi/PR	153	165	174	182	172	185	196	204	196	211	222	232	223	240	253	264	251	270	285	297	277	298	315	328	
	Lo/PR	59	63	69	73	63	67	73	77	65	69	75	80	68	73	79	84	72	76	83	88	74	79	86	92		
	Lo/PR	53.7	55.3	59.8	64.2	52.4	54.0	58.4	62.7	51.2	52.7	57.1	61.2	50.0	51.4	55.7	59.7	47.5	48.9	52.9	56.8	44.0	45.3	49.0	52.6		
	S/T	0.78	0.70	0.53	0.34	0.81	0.73	0.55	0.35	0.83	0.75	0.56	0.36	0.86	0.77	0.58	0.37	0.89	0.80	0.60	0.39	0.90	0.81	0.61	0.39		
	ΔT	22	20	16	11	22	20	16	11	22	20	16	11	22	20	17	11	22	20	16	11	20	19	15	11		
	KW	3.98	4.06	4.18	4.30	4.26	4.35	4.48	4.62	4.52	4.61	4.75	4.90	4.74	4.84	4.99	5.15	4.93	5.04	5.19	5.36	5.10	5.20	5.37	5.54		
	Amps	3.2	3.2	3.3	3.3	3.3	3.3	3.3	3.3	3.3	3.3	3.3	3.4	3.4	3.4	3.4	3.4	3.4	3.4	3.4	3.5	3.4	3.4	3.5	3.5		
Hi/PR	152	163	173	180	170	183	194	202	194	209	220	230	221	238	251	262	248	267	282	294	274	295	312	325			
Lo/PR	59	62	68	72	62	66	72	77	64	68	75	80	68	72	79	84	71	75	82	88	73	78	85	91			
Lo/PR	49.6	51.0	55.2	59.3	48.4	49.8	53.9	57.9	47.3	48.7	52.7	56.5	46.1	47.47	51.4	55.1	43.8	45.1	48.8	52.4	40.6	41.8	45.2	48.5			
S/T	0.76	0.68	0.51	0.33	0.78	0.70	0.53	0.34	0.80	0.72	0.54	0.35	0.83	0.74	0.56	0.36	0.86	0.77	0.58	0.37	0.87	0.78	0.59	0.38			
ΔT	22	20	16	11	22	20	17	12	22	20	17	12	22	21	17	12	22	20	17	12	22	20	17	11			
KW	3.89	3.97	4.08	4.20	4.17	4.25	4.38	4.51	4.41	4.50	4.64	4.79	4.63	4.73	4.87	5.03	4.81	4.92	5.07	5.23	4.97	5.08	5.24	5.41			
Amps	3.2	3.2	3.2	3.3	3.3	3.3	3.3	3.3	3.3	3.3	3.3	3.3	3.3	3.3	3.3	3.4	3.4	3.4	3.4	3.4	3.4	3.4	3.4	3.5			
Hi/PR	147	159	167	175	165	178	188	196	188	202	214	223	214	230	243	254	241	259	274	286	266	286	302	315			
Lo/PR	57	60	66	70	60	64	70	74	62	66	72	77	66	70	76	81	69	73	80	85	71	76	83	88			

IDB: Entering Indoor Dry Bulb Temperature kW = Total system power Shaded area reflects ACCA (TVA) conditions Amps = outdoor unit amps (comp.+fan)
 High and low pressures are measured at the liquid and suction service valves. Design Subcooling 9 ±3 °F @ the liquid service valve, ARI 95 test conditions

EXPANDED COOLING DATA — GSH130604A* / ARUF61-00*-1* / ARUF48601A* (CONT.)

IDB	Airflow	Outdoor Ambient Temperature																								
		65°F					75°F					85°F														
		59	63	67	71	75	59	63	67	71	75	59	63	67	71	75										
2025	MBh	56.29	57.52	61.45	65.69	54.98	56.18	60.02	64.16	53.67	54.84	58.59	62.64	52.36	53.51	57.17	61.11	49.74	50.83	54.31	58.05	46.08	47.09	50.31	53.78	
	S/T	0.90	0.85	0.69	0.51	0.93	0.88	0.71	0.53	0.96	0.90	0.73	0.55	1.00	0.93	0.75	0.56	1.00	0.96	0.78	0.59	1.00	0.97	0.79	0.59	
	ΔT	23	22	19	15	23	22	19	16	23	22	19	16	24	23	20	16	23	22	19	15	21	21	18	14	
	kW	4.04	4.12	4.24	4.37	4.33	4.42	4.55	4.69	4.59	4.68	4.83	4.98	4.82	4.92	5.07	5.23	5.01	5.12	5.28	5.45	5.18	5.29	5.46	5.64	
	Amps	3.2	3.2	3.3	3.3	3.3	3.3	3.3	3.3	3.3	3.3	3.3	3.4	3.4	3.4	3.4	3.4	3.4	3.4	3.4	3.4	3.4	3.5	3.5	3.5	
	Hi-PR	155	167	176	184	174	187	198	206	198	213	225	234	225	242	256	267	253	273	288	300	280	301	318	332	
	Lo-PR	60	64	69	74	63	67	73	78	66	70	76	81	69	73	80	85	72	77	84	89	75	80	87	92	
	80	MBh	54.7	55.8	59.7	63.8	53.4	54.5	58.3	62.3	52.1	53.2	56.9	60.8	50.8	51.9	55.5	59.3	48.3	49.4	52.7	56.4	44.7	45.7	48.8	52.2
		S/T	0.86	0.81	0.66	0.49	0.89	0.84	0.68	0.51	0.91	0.86	0.70	0.52	0.94	0.88	0.72	0.54	0.98	0.92	0.75	0.56	0.99	0.93	0.75	0.56
		ΔT	24	23	20	16	24	23	20	16	24	23	20	16	24	23	20	16	24	23	20	16	23	22	19	15
kW		4.01	4.09	4.21	4.34	4.30	4.38	4.52	4.66	4.55	4.65	4.79	4.94	4.78	4.88	5.03	5.19	4.97	5.08	5.24	5.41	5.14	5.25	5.41	5.59	
Amps		3.2	3.2	3.3	3.3	3.3	3.3	3.3	3.3	3.3	3.3	3.3	3.4	3.4	3.4	3.4	3.4	3.4	3.4	3.4	3.4	3.4	3.5	3.5	3.5	
Hi-PR		153	165	174	182	172	185	196	204	196	211	222	232	223	240	253	264	251	270	285	297	277	298	315	329	
Lo-PR		59	63	69	73	63	67	73	77	65	69	75	80	68	73	79	84	72	76	83	89	74	79	86	92	
1575		MBh	50.4	51.5	55.1	58.9	49.3	50.3	53.8	57.5	48.1	49.1	52.5	56.1	46.9	47.9	51.2	54.8	44.6	45.6	48.7	52.0	41.3	42.2	45.1	48.2
		S/T	0.83	0.78	0.63	0.47	0.86	0.81	0.66	0.49	0.88	0.83	0.67	0.50	0.91	0.85	0.69	0.52	0.94	0.89	0.72	0.54	0.95	0.89	0.73	0.54
		ΔT	24	23	20	16	25	24	21	16	25	24	21	16	25	24	21	17	25	24	20	16	23	22	19	15
	kW	3.92	4.00	4.11	4.24	4.20	4.28	4.41	4.55	4.45	4.54	4.68	4.82	4.67	4.76	4.91	5.07	4.85	4.95	5.11	5.27	5.01	5.12	5.28	5.45	
	Amps	3.2	3.2	3.3	3.3	3.3	3.3	3.3	3.3	3.3	3.3	3.3	3.4	3.3	3.4	3.4	3.4	3.4	3.4	3.4	3.4	3.4	3.4	3.5	3.5	
	Hi-PR	149	160	169	176	167	180	190	198	190	204	216	225	216	233	246	256	243	262	277	288	269	289	306	319	
	Lo-PR	57	61	67	71	61	65	70	75	63	67	73	78	66	70	77	82	69	74	81	86	72	76	83	89	

IDB	Airflow	Outdoor Ambient Temperature																								
		65°F					75°F					85°F														
		59	63	67	71	75	59	63	67	71	75	59	63	67	71	75										
2025	MBh	57.27	58.38	61.15	65.23	55.94	57.02	59.72	63.72	54.61	55.67	58.30	62.20	53.28	54.31	56.88	60.68	50.61	51.59	54.04	57.65	46.88	47.79	50.05	53.40	
	S/T	0.95	0.91	0.82	0.67	0.98	0.95	0.85	0.69	1.00	0.97	0.87	0.71	1.00	1.00	0.90	0.73	1.00	1.00	0.94	0.76	1.00	1.00	0.94	0.77	
	ΔT	25	24	23	20	25	24	23	20	24	25	24	23	20	24	25	23	20	23	23	20	21	22	21	19	
	kW	4.07	4.15	4.27	4.40	4.36	4.45	4.59	4.73	4.62	4.72	4.87	5.02	4.85	4.96	5.11	5.28	5.05	5.16	5.32	5.49	5.22	5.33	5.50	5.68	
	Amps	3.2	3.3	3.3	3.3	3.3	3.3	3.3	3.3	3.3	3.3	3.3	3.4	3.4	3.4	3.4	3.4	3.4	3.4	3.4	3.4	3.4	3.5	3.5	3.5	
	Hi-PR	157	168	178	185	176	189	200	208	200	215	227	237	227	245	258	270	256	275	291	303	283	304	321	335	
	Lo-PR	60	64	70	75	64	68	74	79	66	71	77	82	70	74	81	86	73	78	85	90	76	80	88	93	
	85	MBh	55.6	56.7	59.4	63.3	54.3	55.4	58.0	61.9	53.0	54.0	56.6	60.4	51.7	52.7	55.2	58.9	49.1	50.1	52.5	56.0	45.5	46.4	48.6	51.8
		S/T	0.90	0.87	0.79	0.64	0.93	0.90	0.81	0.66	0.96	0.92	0.83	0.68	0.99	0.95	0.86	0.70	1.00	0.99	0.89	0.73	1.00	1.00	0.90	0.73
		ΔT	26	25	24	21	26	25	24	21	26	26	24	21	26	26	24	21	25	25	24	21	23	24	22	19
kW		4.04	4.12	4.24	4.37	4.33	4.42	4.55	4.69	4.59	4.68	4.83	4.98	4.82	4.92	5.07	5.23	5.01	5.12	5.28	5.45	5.18	5.29	5.46	5.64	
Amps		3.2	3.2	3.3	3.3	3.3	3.3	3.3	3.3	3.3	3.3	3.3	3.4	3.4	3.4	3.4	3.4	3.4	3.4	3.4	3.5	3.4	3.5	3.5	3.5	
Hi-PR		155	167	176	184	174	187	198	206	198	213	225	234	225	242	256	267	253	273	288	300	280	301	318	332	
Lo-PR		60	64	69	74	63	67	73	78	66	70	76	81	69	73	80	85	72	77	84	89	75	80	87	92	
1575		MBh	51.3	52.3	54.8	58.5	50.1	51.1	53.5	57.1	48.9	49.9	52.2	55.7	47.7	48.7	51.0	54.4	45.4	46.2	48.4	51.7	42.0	42.8	44.9	47.9
		S/T	0.87	0.84	0.76	0.61	0.90	0.87	0.78	0.64	0.92	0.89	0.80	0.65	0.95	0.92	0.83	0.67	0.99	0.95	0.86	0.70	1.00	0.96	0.87	0.71
		ΔT	26	26	24	21	26	26	25	21	26	26	25	21	27	26	25	21	26	26	24	21	24	24	23	20
	kW	3.95	4.02	4.14	4.27	4.23	4.32	4.45	4.58	4.48	4.57	4.71	4.86	4.70	4.80	4.95	5.11	4.89	4.99	5.15	5.32	5.05	5.16	5.32	5.50	
	Amps	3.2	3.2	3.2	3.3	3.3	3.3	3.3	3.3	3.3	3.3	3.3	3.4	3.3	3.4	3.4	3.4	3.4	3.4	3.4	3.4	3.4	3.4	3.4	3.5	
	Hi-PR	150	162	171	178	169	181	192	200	192	206	218	227	218	235	248	259	246	264	279	291	272	292	309	322	
	Lo-PR	58	62	67	72	61	65	71	76	64	68	74	79	67	71	78	83	70	75	81	87	73	77	84	90	

IDB: Entering Indoor Dry Bulb Temperature kW = Total system power Shaded area reflects ARI Rating conditions Amps = outdoor unit amps (comp.+fan)
 High and low pressures are measured at the liquid and suction service valves. Design Subcooling 9 ±3 °F @ the liquid service valve, ARI 95 test conditions

EXPANDED HEATING DATA

GSH130181A* / ARUF32-00*-1* / ARUF18241A*

	Outdoor Ambient Temperature																	
	65	60	55	50	47	45	40	35	30	25	20	17	15	10	5	0	-5	-10
MBh	21.1	20.0	18.8	17.6	16.8	16.3	15.1	13.9	10.7	9.9	9.1	8.6	8.3	7.4	6.6	5.7	4.9	4.0
ΔT	32.6	30.9	29.0	27.1	25.9	25.1	23.3	21.5	16.5	15.3	14.1	13.3	12.8	11.5	10.2	8.9	7.6	6.2
kW	1.57	1.54	1.51	1.48	1.46	1.45	1.42	1.39	1.30	1.27	1.24	1.23	1.22	1.19	1.16	1.13	1.10	1.08
Amps	7.3	6.8	6.4	6.0	5.8	5.7	5.4	5.1	4.9	4.7	4.4	4.3	4.3	4.1	3.8	3.6	3.3	3.0
COP	3.94	3.80	3.65	3.48	3.36	3.29	3.12	2.94	2.41	2.28	2.14	2.05	1.99	1.83	1.66	1.49	1.30	1.09
EER	13.5	13.0	12.5	11.9	11.5	11.2	10.6	10.0	8.2	7.8	7.3	7.0	6.8	6.3	5.7	5.1	4.4	3.7
Hi PR	241	231	222	213	208	204	196	188	180	172	165	161	158	152	146	140	135	131
Lo PR	83	77	72	66	62	60	55	49	44	40	35	32	31	26	23	19	17	13

GSH130181B* / AR*F182416**

	Outdoor Ambient Temperature																	
	65	60	55	50	47	45	40	35	30	25	20	17	15	10	5	0	-5	-10
MBh	21.1	20.0	18.8	17.6	16.8	16.3	15.1	13.9	10.8	10.0	9.2	8.7	8.4	7.5	6.7	5.8	5.0	4.1
ΔT	30.1	28.5	26.8	25.1	23.9	23.2	21.5	19.9	15.4	14.3	13.1	12.4	11.9	10.7	9.5	8.3	7.1	5.8
KW	1.55	1.53	1.50	1.47	1.45	1.44	1.41	1.38	1.36	1.33	1.30	1.28	1.27	1.24	1.21	1.18	1.15	1.12
AMPS	7.2	6.7	6.3	5.9	5.7	5.6	5.3	5.0	4.8	4.6	4.4	4.3	4.2	4.0	3.7	3.5	3.3	3.0
COP	3.98	3.84	3.68	3.51	3.39	3.31	3.14	2.96	2.34	2.21	2.08	1.99	1.93	1.78	1.61	1.44	1.26	1.06
EER	13.6	13.1	12.6	12.0	11.6	11.3	10.7	10.1	8.0	7.5	7.1	6.8	6.6	6.1	5.5	4.9	4.3	3.6
HI PR	252	242	232	222	217	213	205	196	188	180	173	168	165	159	153	147	141	136
LO PR	82	76	72	66	62	60	55	49	44	39	35	32	31	26	23	19	17	13

GSH13019-1A* / AWUF18XX1A*

	Outdoor Ambient Temperature																	
	65	60	55	50	47	45	40	35	30	25	20	17	15	10	5	0	-5	-10
MBh	21.1	20.0	18.8	17.6	16.8	16.3	15.1	13.9	10.7	9.9	9.1	8.6	8.3	7.4	6.6	5.7	4.9	4.0
ΔT	32.6	30.9	29.0	27.1	25.9	25.1	23.3	21.5	16.5	15.3	14.1	13.3	12.8	11.5	10.2	8.9	7.6	6.2
kW	1.66	1.63	1.60	1.57	1.55	1.54	1.51	1.48	1.51	1.47	1.44	1.42	1.41	1.38	1.35	1.32	1.28	1.25
Amps	6.3	5.9	5.5	5.2	5.1	5.0	4.7	4.5	4.3	4.2	4.0	3.9	3.9	3.7	3.5	3.3	3.1	2.8
COP	3.73	3.59	3.45	3.29	3.17	3.10	2.94	2.76	2.08	1.96	1.85	1.77	1.72	1.58	1.43	1.28	1.12	0.94
EER	12.7	12.3	11.8	11.2	10.8	10.6	10.0	9.4	7.1	6.7	6.3	6.0	5.9	5.4	4.9	4.4	3.8	3.2
Hi PR	285	273	262	251	245	240	231	222	212	203	195	190	187	180	173	166	160	154
Lo PR	84	78	73	67	64	61	56	50	45	40	36	33	32	27	23	20	17	13

GSH130241A* / ARUF32-00*-1* / ARUF18241A*

	Outdoor Ambient Temperature																	
	65	60	55	50	47	45	40	35	30	25	20	17	15	10	5	0	-5	-10
MBh	27.7	26.2	24.6	23.0	22.0	21.3	19.8	18.3	15.0	13.8	12.7	12.0	11.6	10.4	9.2	8.0	6.8	5.6
ΔT	31.2	29.6	27.8	26.0	24.8	24.1	22.4	20.6	16.9	15.6	14.3	13.6	13.0	11.7	10.4	9.1	7.7	6.3
kW	2.09	2.05	2.01	1.97	1.95	1.93	1.89	1.85	1.76	1.73	1.69	1.66	1.65	1.61	1.57	1.53	1.49	1.46
Amps	9.6	8.9	8.3	7.8	7.6	7.4	7.0	6.6	6.4	6.1	5.8	5.7	5.6	5.3	4.9	4.7	4.3	3.9
COP	3.87	3.73	3.58	3.42	3.30	3.23	3.06	2.89	2.48	2.34	2.20	2.11	2.05	1.89	1.71	1.53	1.34	1.13
EER	13.2	12.8	12.2	11.7	11.3	11.0	10.5	9.9	8.5	8.0	7.5	7.2	7.0	6.4	5.9	5.2	4.6	3.9
Hi PR	261	250	240	230	224	220	212	203	195	186	178	174	171	164	158	152	146	141
Lo PR	80	74	70	64	61	58	54	48	43	38	34	31	30	26	22	19	16	13

See Notes on Page 43.

EXPANDED HEATING DATA (CONT.)

GSH130241B* / AR*F182416**

	Outdoor Ambient Temperature																	
	65	60	55	50	47	45	40	35	30	25	20	17	15	10	5	0	-5	-10
MBh	27.7	26.2	24.6	23.0	22.0	21.3	19.8	18.3	15.0	13.8	12.7	12.0	11.6	10.4	9.2	8.0	6.8	5.6
ΔT	30.1	28.5	26.8	25.1	24.0	23.2	21.6	19.9	16.3	15.0	13.8	13.1	12.6	11.3	10.0	8.7	7.5	6.1
KW	1.99	1.95	1.91	1.87	1.85	1.84	1.80	1.76	1.70	1.66	1.62	1.60	1.59	1.55	1.51	1.48	1.44	1.40
AMPS	9.0	8.3	7.8	7.3	7.1	6.9	6.5	6.2	5.9	5.7	5.4	5.3	5.2	4.9	4.6	4.3	4.0	3.6
COP	4.07	3.93	3.77	3.60	3.47	3.40	3.22	3.03	2.58	2.44	2.29	2.19	2.13	1.96	1.78	1.59	1.39	1.17
EER	13.9	13.4	12.9	12.3	11.9	11.6	11.0	10.4	8.8	8.3	7.8	7.5	7.3	6.7	6.1	5.4	4.8	4.0
HI PR	238	228	220	210	205	201	193	186	178	170	163	159	156	150	145	139	134	129
LO PR	80	74	69	63	60	58	53	47	43	38	33	31	30	25	22	18	16	13

GSH130251A* / AWUF36XX1A*

	Outdoor Ambient Temperature																	
	65	60	55	50	47	45	40	35	30	25	20	17	15	10	5	0	-5	-10
MBh	28.4	26.9	25.3	23.7	22.6	21.9	20.3	18.8	17.1	15.7	14.5	13.7	13.2	11.8	10.5	9.1	7.8	6.4
ΔT	32.1	30.4	28.6	26.7	25.5	24.7	23.0	21.2	19.3	17.8	16.4	15.5	14.9	13.4	11.8	10.3	8.8	7.2
kW	2.31	2.27	2.23	2.18	2.16	2.14	2.10	2.05	1.90	1.86	1.82	1.80	1.78	1.74	1.70	1.66	1.62	1.58
Amps	11.1	10.3	9.7	9.1	8.8	8.7	8.2	7.8	7.5	7.2	6.9	6.8	6.7	6.4	6.0	5.7	5.3	4.9
COP	3.59	3.47	3.33	3.17	3.07	3.00	2.84	2.67	2.62	2.48	2.33	2.23	2.17	1.99	1.81	1.61	1.41	1.19
EER	12.3	11.8	11.4	10.8	10.5	10.2	9.7	9.1	9.0	8.5	8.0	7.6	7.4	6.8	6.2	5.5	4.8	4.0
Hi PR	267	256	246	236	230	226	217	208	199	190	183	178	175	169	162	155	150	145
Lo PR	76	71	66	61	58	55	51	45	41	37	32	30	29	24	21	18	15	12

GSH130301A* / ARUF42-00*-01* / ARUF30301A*

	Outdoor Ambient Temperature																	
	65	60	55	50	47	45	40	35	30	25	20	17	15	10	5	0	-5	-10
MBh	33.7	31.9	30.0	28.1	26.8	26.0	24.1	22.2	17.4	16.1	14.8	14.0	13.5	12.1	10.7	9.4	8.0	6.5
ΔT	29.7	28.1	26.5	24.7	23.6	22.9	21.3	19.6	15.4	14.2	13.1	12.3	11.9	10.7	9.5	8.2	7.0	5.8
kW	2.41	2.36	2.32	2.27	2.24	2.22	2.18	2.13	2.08	2.04	1.99	1.96	1.95	1.90	1.85	1.81	1.76	1.72
Amps	11.1	10.3	9.6	9.1	8.7	8.6	8.1	7.7	7.3	7.0	6.7	6.5	6.4	6.1	5.7	5.3	4.9	4.4
COP	4.09	3.95	3.79	3.62	3.50	3.42	3.24	3.05	2.45	2.31	2.18	2.09	2.03	1.86	1.69	1.51	1.32	1.11
EER	14.0	13.5	13.0	12.4	11.9	11.7	11.1	10.4	8.4	7.9	7.4	7.1	6.9	6.4	5.8	5.2	4.5	3.8
Hi PR	234	224	216	206	202	198	190	182	175	167	160	156	154	148	142	136	131	127
Lo PR	76	70	66	61	57	55	51	45	41	36	32	30	29	24	21	18	15	12

GSH130311A* / AWB36-XX / AWUF36XX1A*

	Outdoor Ambient Temperature																	
	65	60	55	50	47	45	40	35	30	25	20	17	15	10	5	0	-5	-10
MBh	32.2	30.5	28.7	26.8	25.6	24.8	23.0	21.2	23.7	21.8	20.1	19.0	18.3	16.4	14.5	12.7	10.8	8.9
ΔT	28.4	26.9	25.3	23.6	22.6	21.9	20.3	18.7	20.9	19.3	17.7	16.7	16.1	14.5	12.8	11.2	9.5	7.8
kW	2.55	2.49	2.44	2.39	2.36	2.33	2.28	2.23	2.00	1.95	1.90	1.87	1.86	1.81	1.76	1.71	1.66	1.62
Amps	12.6	11.7	11.0	10.3	10.0	9.8	9.3	8.8	8.5	8.1	7.7	7.6	7.5	7.1	6.7	6.3	5.9	5.3
COP	3.70	3.58	3.44	3.29	3.18	3.11	2.96	2.79	3.47	3.28	3.09	2.97	2.89	2.66	2.42	2.17	1.90	1.61
EER	12.6	12.2	11.8	11.2	10.9	10.6	10.1	9.5	11.8	11.2	10.6	10.1	9.9	9.1	8.3	7.4	6.5	5.5
Hi PR	254	243	234	224	218	214	206	198	189	181	174	170	166	160	154	148	142	137
Lo PR	76	71	66	61	57	55	51	45	41	36	32	30	29	24	21	18	15	12

See Notes on Page 43.

EXPANDED HEATING DATA (CONT.)

GSH130361A* / ARUF49-00*-1* / ARUF36421A*

	Outdoor Ambient Temperature																	
	65	60	55	50	47	45	40	35	30	25	20	17	15	10	5	0	-5	-10
MBh	40.2	38.1	35.8	33.5	32.0	31.0	28.8	26.6	19.9	18.4	16.9	16.0	15.4	13.8	12.3	10.7	9.1	7.5
ΔT	29.2	27.7	26.0	24.3	23.2	22.5	20.9	19.3	14.5	13.4	12.3	11.6	11.2	10.0	8.9	7.8	6.6	5.4
kW	2.90	2.84	2.79	2.73	2.70	2.68	2.63	2.58	2.42	2.37	2.32	2.29	2.27	2.22	2.17	2.12	2.07	2.02
Amps	13.0	12.1	11.3	10.7	10.3	10.1	9.5	9.1	8.7	8.3	7.9	7.7	7.6	7.3	6.8	6.4	5.9	5.4
COP	4.07	3.92	3.76	3.59	3.46	3.39	3.21	3.02	2.41	2.27	2.14	2.05	1.99	1.82	1.65	1.48	1.29	1.08
EER	13.9	13.4	12.9	12.3	11.8	11.6	11.0	10.3	8.2	7.8	7.3	7.0	6.8	6.2	5.7	5.0	4.4	3.7
Hi PR	230	221	212	203	198	194	187	179	172	164	158	154	151	145	140	134	129	125
Lo PR	80	74	70	64	60	58	54	48	43	38	34	31	30	26	22	19	16	13

GSH130363A* / ARUF49-00*-1* / ARUF36421A*

	Outdoor Ambient Temperature																	
	65	60	55	50	47	45	40	35	30	25	20	17	15	10	5	0	-5	-10
MBh	40.2	38.1	35.8	33.5	32.0	31.0	28.8	26.6	19.9	18.4	16.9	16.0	15.4	13.8	12.3	10.7	9.1	7.5
ΔT	29.2	27.7	26.0	24.3	23.2	22.5	20.9	19.3	14.5	13.4	12.3	11.6	11.2	10.0	8.9	7.8	6.6	5.4
kW	2.80	2.75	2.70	2.64	2.61	2.59	2.54	2.49	2.47	2.41	2.36	2.33	2.31	2.25	2.20	2.15	2.09	2.04
Amps	11.0	10.2	9.6	9.1	8.7	8.6	8.1	7.7	7.4	7.1	6.8	6.6	6.5	6.2	5.8	5.5	5.1	4.7
COP	4.20	4.05	3.89	3.71	3.58	3.50	3.32	3.13	2.36	2.23	2.10	2.01	1.95	1.79	1.63	1.46	1.27	1.07
EER	14.4	13.9	13.3	12.7	12.2	12.0	11.3	10.7	8.1	7.6	7.2	6.9	6.7	6.1	5.6	5.0	4.4	3.7
Hi PR	219	210	202	193	189	185	178	171	164	156	150	146	144	138	133	128	123	119
Lo PR	78	72	67	62	58	56	52	46	42	37	33	30	29	25	21	18	16	12

GSH130421A* / ARUF49-00*-1* / ARUF36421A*

	Outdoor Ambient Temperature																	
	65	60	55	50	47	45	40	35	30	25	20	17	15	10	5	0	-5	-10
MBh	49.0	46.4	43.7	40.8	39.0	37.8	35.1	32.4	28.7	26.5	24.4	23.0	22.1	19.9	17.6	15.4	13.1	10.7
ΔT	30.3	28.6	27.0	25.2	24.1	23.3	21.7	20.0	17.7	16.3	15.0	14.2	13.7	12.3	10.9	9.5	8.1	6.6
kW	3.59	3.52	3.46	3.39	3.35	3.32	3.26	3.19	3.08	3.01	2.95	2.91	2.88	2.82	2.75	2.69	2.62	2.56
Amps	16.7	15.5	14.5	13.6	13.1	12.9	12.1	11.5	11.0	10.5	10.0	9.8	9.7	9.2	8.6	8.1	7.4	6.7
COP	4.00	3.86	3.70	3.53	3.41	3.33	3.15	2.97	2.72	2.57	2.42	2.31	2.25	2.06	1.87	1.67	1.46	1.23
EER	13.7	13.2	12.6	12.1	11.6	11.4	10.8	10.1	9.3	8.8	8.3	7.9	7.7	7.1	6.4	5.7	5.0	4.2
Hi PR	237	227	218	209	204	200	192	184	177	169	162	158	155	149	144	138	133	128
Lo PR	75	70	65	60	57	54	50	45	40	36	32	29	28	24	21	17	15	12

GSH130481A* / ARUF61-00*-1* / ARUF48601A*

	Outdoor Ambient Temperature																	
	65	60	55	50	47	45	40	35	30	25	20	17	15	10	5	0	-5	-10
MBh	54.1	51.2	48.2	45.0	43.0	41.7	38.7	35.7	33.6	31.1	28.6	27.0	26.0	23.3	20.7	18.0	15.4	12.6
ΔT	31.3	29.6	27.9	26.1	24.9	24.1	22.4	20.7	19.5	18.0	16.5	15.6	15.0	13.5	12.0	10.4	8.9	7.3
kW	3.84	3.77	3.70	3.63	3.59	3.56	3.49	3.42	3.34	3.27	3.20	3.16	3.13	3.06	3.00	2.93	2.86	2.79
Amps	18.1	16.8	15.7	14.8	14.3	14.0	13.2	12.5	12.0	11.5	10.9	10.7	10.5	10.0	9.3	8.8	8.1	7.3
COP	4.12	3.98	3.81	3.63	3.51	3.43	3.24	3.05	2.95	2.78	2.62	2.50	2.43	2.23	2.02	1.80	1.58	1.32
EER	14.1	13.6	13.0	12.4	12.0	11.7	11.1	10.4	10.1	9.5	8.9	8.5	8.3	7.6	6.9	6.2	5.4	4.5
Hi PR	224	215	207	198	193	189	182	175	167	160	154	150	147	142	136	131	126	121
Lo PR	74	69	64	59	56	54	49	44	40	35	31	29	28	24	20	17	15	12

See Notes on Page 43.

EXPANDED HEATING DATA (CONT.)

GSH130483A* / ARUF61-00*-1* / ARUF48601A*

	Outdoor Ambient Temperature																	
	65	60	55	50	47	45	40	35	30	25	20	17	15	10	5	0	-5	-10
MBh	54.1	51.2	48.2	45.0	43.0	41.7	38.7	35.7	33.6	31.1	28.6	27.0	26.0	23.3	20.7	18.0	15.4	12.6
ΔT	31.3	29.6	27.9	26.1	24.9	24.1	22.4	20.7	19.5	18.0	16.5	15.6	15.0	13.5	12.0	10.4	8.9	7.3
kW	3.71	3.64	3.57	3.50	3.45	3.42	3.35	3.28	3.34	3.26	3.19	3.14	3.11	3.04	2.96	2.89	2.81	2.74
Amps	14.6	13.6	12.7	12.0	11.6	11.3	10.7	10.2	9.8	9.3	8.9	8.7	8.6	8.2	7.7	7.2	6.7	6.1
COP	4.26	4.11	3.95	3.77	3.64	3.56	3.38	3.18	2.95	2.79	2.63	2.51	2.44	2.25	2.04	1.83	1.60	1.35
EER	14.6	14.1	13.5	12.9	12.4	12.2	11.5	10.9	10.1	9.5	9.0	8.6	8.4	7.7	7.0	6.2	5.5	4.6
Hi PR	224	215	206	197	193	189	182	174	167	159	153	149	147	141	136	130	126	121
Lo PR	73	68	64	58	55	53	49	44	39	35	31	29	28	23	20	17	15	12

GSH130601A* / ARUF61-00*-1* / ARUF48601A*

	Outdoor Ambient Temperature																	
	65	60	55	50	47	45	40	35	30	25	20	17	15	10	5	0	-5	-10
MBh	69.8	66.0	62.2	58.1	55.5	53.8	50.0	46.1	43.6	40.3	37.1	35.0	33.7	30.2	26.8	23.4	20.0	16.3
ΔT	35.9	34.0	32.0	29.9	28.5	27.7	25.7	23.7	22.4	20.7	19.1	18.0	17.3	15.6	13.8	12.0	10.3	8.4
kW	5.04	4.95	4.85	4.75	4.70	4.66	4.57	4.47	4.30	4.21	4.11	4.06	4.02	3.93	3.84	3.75	3.65	3.56
Amps	22.7	21.0	19.6	18.4	17.8	17.4	16.4	15.6	14.9	14.2	13.5	13.2	13.0	12.4	11.5	10.8	10.0	9.0
COP	4.05	3.91	3.75	3.58	3.46	3.38	3.20	3.02	2.97	2.80	2.64	2.52	2.45	2.25	2.05	1.83	1.60	1.34
EER	13.8	13.4	12.8	12.2	11.8	11.5	10.9	10.3	10.1	9.6	9.0	8.6	8.4	7.7	7.0	6.2	5.5	4.6
Hi PR	255	244	235	225	219	215	207	198	190	182	174	170	167	161	155	148	143	138
Lo PR	75	70	65	60	57	54	50	45	40	36	32	29	28	24	21	17	15	12

GSH130603A* / ARUF61-00*-1* / ARUF48601A*

	Outdoor Ambient Temperature																	
	65	60	55	50	47	45	40	35	30	25	20	17	15	10	5	0	-5	-10
MBh	69.8	66.0	62.2	58.1	55.5	53.8	50.0	46.1	43.6	40.3	37.1	35.0	33.7	30.2	26.8	23.4	20.0	16.3
ΔT	35.9	34.0	32.0	29.9	28.5	27.7	25.7	23.7	22.4	20.7	19.1	18.0	17.3	15.6	13.8	12.0	10.3	8.4
kW	5.58	5.47	5.35	5.24	5.17	5.12	5.01	4.89	4.37	4.27	4.17	4.11	4.07	3.96	3.86	3.76	3.65	3.55
Amps	22.1	20.4	19.1	18.0	17.3	17.0	16.0	15.2	14.5	13.9	13.2	12.9	12.7	12.1	11.2	10.6	9.8	8.8
COP	3.66	3.54	3.40	3.25	3.14	3.07	2.92	2.75	2.92	2.76	2.60	2.49	2.43	2.23	2.03	1.82	1.60	1.35
EER	12.5	12.1	11.6	11.1	10.7	10.5	10.0	9.4	10.0	9.4	8.9	8.5	8.3	7.6	6.9	6.2	5.5	4.6
Hi PR	273	262	252	241	235	231	222	213	204	195	187	182	179	172	166	159	153	148
Lo PR	72	67	63	58	54	52	48	43	39	35	30	28	27	23	20	17	15	11

High pressure is measured at the suction service valve (the larger valve).

Amps = Outdoor unit amps (comp.+fan)

Low pressure is measured at the gauge port connection.

kW = Total system power

Calculations are based on nominal CFM and 70 °F indoor dry bulb.

ARI PERFORMANCE RATINGS

Outdoor Unit	Indoor Units		Cooling (BTU/h)				TVA Ratings		Heating (BTU/h)			ARI #
	Indoor Coil	Furnace/ Blower	Total	Sens.	SEER ¹	EER ²	Total	Sens.	High	HSPF ³	Low	
GSH13 0181A*	ADPF182416A*		18,000	13,100	13.00	11.50	16,700	13,000	16,800	7.70	8,600	1038042
	ADPF182416B*		18,000	13,100	13.00	11.50	16,700	13,000	16,800	7.70	8,600	1443950
	ADPF18241A*		18,000	13,100	13.00	11.50	16,700	13,000	16,800	7.70	8,600	735155
	ADPF18241B*		18,000	13,100	13.00	11.50	16,700	13,000	16,800	7.70	8,600	1069210
	AEPF183016A*		18,000	13,100	14.00	12.20	16,700	13,000	16,800	8.00	8,600	1038043
	AEPF183016B*		18,000	13,100	14.00	12.20	16,700	13,000	16,800	8.00	8,600	1277840
	AEPF183016C*		18,000	13,100	14.00	12.20	16,700	13,000	16,800	8.00	8,600	1492541
	AEPF18301A*		18,000	13,100	14.00	12.20	16,700	13,000	16,800	8.00	8,600	735122
	AEPF18301B*		18,000	13,100	14.00	12.20	16,700	13,000	16,800	8.00	8,600	1069211
	AEPT030-00*-1*		18,000	13,100	14.00	12.20	16,700	13,000	16,800	8.00	8,600	735070
	AR*F182416B*		18,000	13,100	13.00	11.50	16,700	13,000	16,800	7.70	8,600	1443966
	ARPF036-00B-1*		18,000	13,100	13.00	11.50	16,700	13,000	16,800	7.70	8,600	735104
	ARPF182416A*		18,000	13,100	13.00	11.50	16,700	13,000	16,800	7.70	8,600	1038044
	ARPF18241A*		18,000	13,100	13.00	11.50	16,700	13,000	16,800	7.70	8,600	735242
	ARPF18241B*		18,000	13,100	13.00	11.50	16,700	13,000	16,800	7.70	8,600	1069212
	ARPT032-00*-1*		18,000	13,100	13.00	11.50	16,700	13,000	16,800	7.70	8,600	735119
	ARUF032-00*-1*		18,000	13,100	13.00	11.50	16,700	13,000	16,800	7.70	8,600	735244
	ARUF182416A*		18,000	13,100	13.00	11.50	16,700	13,000	16,800	7.70	8,600	1038045
	ARUF18241A*		18,000	13,100	13.00	11.50	16,700	13,000	16,800	7.70	8,600	735073
	ARUF18241B*		18,000	13,100	13.00	11.50	16,700	13,000	16,800	7.70	8,600	1069213
	ASPF183016A*		18,000	13,100	14.00	12.20	16,700	13,000	16,800	8.00	8,600	1291677
	ASPF183016B*		18,000	13,100	14.00	12.20	16,700	13,000	16,800	8.00	8,600	1492542
	AT*F182416A*		18,000	13,100	13.00	11.50	16,700	13,000	16,800	7.70	8,600	1483524
	CA*F030*2*	G*V80704B**	18,000	13,100	14.00	12.20	16,700	13,000	16,800	8.00	8,600	735054
	CA*F030*2*	G*V950453B**	18,000	13,100	13.50	11.80	16,700	13,000	16,800	7.70	8,600	735168
	CA*F030*2*+EEP		18,000	13,100	13.00	11.50	16,700	13,000	16,800	7.70	8,600	735193
	CA*F030*2*	MBE1200**-1	18,000	13,100	14.00	12.20	16,700	13,000	16,800	8.00	8,600	1032335
	CA*F1824*6A*	G*E80704B**	18,000	13,100	14.00	12.20	16,700	13,000	16,800	8.00	8,600	1273326
	CA*F1824*6A*	G*V80704B**	18,000	13,100	14.00	12.20	16,700	13,000	16,800	8.00	8,600	735059
	CA*F1824*6A*	G*V950453B**	18,000	13,100	13.50	11.80	16,700	13,000	16,800	7.70	8,600	735141
	CA*F1824*6A*+EEP		18,000	13,100	13.00	11.50	16,700	13,000	16,800	7.70	8,600	735078
	CA*F1824*6A*	MBE1200**-1	18,000	13,100	14.00	12.20	16,700	13,000	16,800	8.00	8,600	1032328
	CA*F1824*6B*	G*E80704B**	18,000	13,100	14.00	12.20	16,700	13,000	16,800	8.00	8,600	1347185
	CA*F1824*6B*	G*V80704B**	18,000	13,100	14.00	12.20	16,700	13,000	16,800	8.00	8,600	1347186
	CA*F1824*6B*	G*V950453B**	18,000	13,100	13.50	11.80	16,700	13,000	16,800	7.70	8,600	1347187
	CA*F1824*6B*+EEP		18,000	13,100	13.00	11.50	16,700	13,000	16,800	7.70	8,600	1347188
	CA*F1824*6B*	MBE1200**-1	18,000	13,100	14.00	12.20	16,700	13,000	16,800	8.00	8,600	1346677
	CA*F1824*6C*	G*E80704B**	18,000	13,100	14.00	12.20	16,700	13,000	16,800	8.00	8,600	1386235
	CA*F1824*6C*	G*V80704B**	18,000	13,100	14.00	12.20	16,700	13,000	16,800	8.00	8,600	1401059
	CA*F1824*6C*	G*V950453B**	18,000	13,100	13.50	11.80	16,700	13,000	16,800	7.70	8,600	1401060
	CA*F1824*6C*+EEP		18,000	13,100	13.00	11.50	16,700	13,000	16,800	7.70	8,600	1401061
	CA*F1824*6C*	MBE1200**-1	18,000	13,100	14.00	12.20	16,700	13,000	16,800	8.00	8,600	1386236
CHPF030A2*+EEP		18,000	13,100	13.00	11.50	16,700	13,000	16,800	7.70	8,600	735060	
CHPF042B2*	G*V80704B**	18,000	13,100	14.00	12.20	16,700	13,000	16,800	8.00	8,600	735176	
CHPF042B2*	G*V950453B**	18,000	13,100	13.50	11.80	16,700	13,000	16,800	7.70	8,600	735840	
CHPF1824A6A*+EEP		18,000	13,100	13.00	11.50	16,700	13,000	16,800	7.70	8,600	735085	

¹ Seasonal Energy Efficiency Ratio; Certified per ARI 210/240 @ 80°F/ 67°F/ 95°F

² Energy Efficiency Ratio @ 80°F/ 67°F/ 95°F

³ TVA Rating: BTU/h @ 75°F/ 63°F - 95°F

⁴ HSPF = Heating Seasonal Performance Factor

Notes:

- Always check the S&R plate for electrical data on the unit being installed.
- When matching the outdoor unit to the indoor unit, use the piston supplied with the outdoor unit or that specified on the piston kit chart supplied with the indoor unit.
- EEP - Order from Service Dept. Part No. B13707-38 or new Solid State Board B13707-35S. Part No. B13707-38 is not interchangeable with B13707-35S. The Goodman Gas Furnace contains the EEP cooling time delay

ARI PERFORMANCE RATINGS (CONT.)

Outdoor Unit	Indoor Units		Cooling (BTU/h)				TVA Ratings		Heating (BTU/h)			ARI #
	Indoor Coil	Furnace/ Blower	Total	Sens.	SEER ¹	EER ²	Total	Sens.	High	HSPF ³	Low	
GSH13 0181B*	CHPF2430B6A*	G*E80704B**	18,000	13,100	14.00	12.20	16,700	13,000	16,800	8.00	8,600	1273327
	CHPF2430B6A*	G*V80704B**	18,000	13,100	14.00	12.20	16,700	13,000	16,800	8.00	8,600	735232
	CHPF2430B6A*	G*V950453B**	18,000	13,100	13.50	11.80	16,700	13,000	16,800	7.70	8,600	735991
	CHPF2430B6B*	G*E80704B**	18,000	13,100	14.00	12.20	16,700	13,000	16,800	8.00	8,600	1347582
	CHPF2430B6B*	G*V80704B**	18,000	13,100	14.00	12.20	16,700	13,000	16,800	8.00	8,600	1330383
	CHPF2430B6B*	G*V950453B**	18,000	13,100	13.50	11.80	16,700	13,000	16,800	7.70	8,600	1330384
	CHPF2430B6B*+EEP		18,000	13,100	13.00	11.50	16,700	13,000	16,800	7.70	8,600	1330382
	CSCF1824N6A*	G*E80704B**	18,000	13,100	14.00	12.20	16,700	13,000	16,800	8.00	8,600	1273328
	CSCF1824N6A*	G*V80704B**	18,000	13,100	14.00	12.20	16,700	13,000	16,800	8.00	8,600	735037
	CSCF1824N6A*	G*V950453B**	18,000	13,100	13.50	11.80	16,700	13,000	16,800	7.70	8,600	735816
	CSCF1824N6A*+EEP		18,000	13,100	13.00	11.50	16,700	13,000	16,800	7.70	8,600	735127
	CSCF3036N6B*	G*E80704B**	18,000	13,100	14.00	12.20	16,700	13,000	16,800	8.00	8,600	1296608
	CSCF3036N6B*	G*V80704B**	18,000	13,100	14.00	12.20	16,700	13,000	16,800	8.00	8,600	1296609
	CSCF3036N6B*	G*V950453B**	18,000	13,100	13.50	11.80	16,700	13,000	16,800	7.70	8,600	1296610
	CSCF3036N6B*+EEP		18,000	13,100	13.00	11.50	16,700	13,000	16,800	7.70	8,600	1296611
	CT*F1824*6A*	G*E80704B**	18,000	13,100	14.00	12.20	16,700	13,000	16,800	8.00	8,600	1449919
	CT*F1824*6A*	G*V80704B**	18,000	13,100	14.00	12.20	16,700	13,000	16,800	8.00	8,600	1449920
	CT*F1824*6A*	G*V950453B**	18,000	13,100	13.50	11.80	16,700	13,000	16,800	7.70	8,600	1449921
	CT*F1824*6A*+EEP		18,000	13,100	13.00	11.50	16,700	13,000	16,800	7.70	8,600	1449922
	CT*F1824*6A*	MBE1200**-1	18,000	13,100	14.00	12.20	16,700	13,000	16,800	8.00	8,600	1449923
	H36F	G*V80704B**	18,000	13,100	14.00	12.20	16,700	13,000	16,800	8.00	8,600	735094
	H36F	G*V950453B**	18,000	13,100	13.50	11.80	16,700	13,000	16,800	7.70	8,600	735843
	H36F+EEP		18,000	13,100	13.00	11.50	16,700	13,000	16,800	7.70	8,600	735076
	ADPF182416A*		18,000	13,100	13.00	11.50	16,700	13,000	16,800	7.70	8,600	3160464
	ADPF182416B*		18,000	13,100	13.00	11.50	16,700	13,000	16,800	7.70	8,600	318401
	AEPF183016B*		18,000	13,100	14.00	12.20	16,700	13,000	16,800	8.00	8,600	3160465
	AEPF183016C*		18,000	13,100	14.00	12.20	16,700	13,000	16,800	8.00	8,600	3160466
	AR*F182416A*		18,000	13,100	13.00	11.50	16,700	13,000	16,800	7.70	8,600	3160468
	AR*F182416B*		18,000	13,100	13.00	11.50	16,700	13,000	16,800	7.70	8,600	3160467
	ASPF183016A*		18,000	13,100	14.00	12.20	16,700	13,000	16,800	8.00	8,600	3160469
	ASPF183016B*		18,000	13,100	14.00	12.20	16,700	13,000	16,800	8.00	8,600	3160470
	AT*F182416A*		18,000	13,100	13.00	11.50	16,700	13,000	16,800	7.70	8,600	3160471
	CA*F1824*6B*	G*E80704B**	18,000	13,100	14.00	12.20	16,700	13,000	16,800	8.00	8,600	3160472
	CA*F1824*6B*	G*V80704B**	18,000	13,100	14.00	12.20	16,700	13,000	16,800	8.00	8,600	3160473
	CA*F1824*6B*	G*V950453B**	18,000	13,100	13.50	11.80	16,700	13,000	16,800	7.70	8,600	3160474
	CA*F1824*6B*+EEP		18,000	13,100	13.00	11.50	16,700	13,000	16,800	7.70	8,600	3160475
	CA*F1824*6B*	MBE1200**-1	18,000	13,100	14.00	12.20	16,700	13,000	16,800	8.00	8,600	3160476
	CA*F1824*6C*	G*E80704B**	18,000	13,100	14.00	12.20	16,700	13,000	16,800	8.00	8,600	3160477
	CA*F1824*6C*	G*V80704B**	18,000	13,100	14.00	12.20	16,700	13,000	16,800	8.00	8,600	3160478
	CA*F1824*6C*	G*V950453B**	18,000	13,100	13.50	11.80	16,700	13,000	16,800	7.70	8,600	3160479
	CA*F1824*6C*+EEP		18,000	13,100	13.00	11.50	16,700	13,000	16,800	7.70	8,600	3160480
	CA*F1824*6C*	MBE1200**-1	18,000	13,100	14.00	12.20	16,700	13,000	16,800	8.00	8,600	3160481
	CHPF2430B6B*	G*E80704B**	18,000	13,100	14.00	12.20	16,700	13,000	16,800	8.00	8,600	3160482
	CHPF2430B6B*	G*V80704B**	18,000	13,100	14.00	12.20	16,700	13,000	16,800	8.00	8,600	3160483
	CHPF2430B6B*	G*V950453B**	18,000	13,100	13.50	11.80	16,700	13,000	16,800	7.70	8,600	3160484
	CHPF2430B6B*+EEP		18,000	13,100	13.00	11.50	16,700	13,000	16,800	7.70	8,600	3160485
	CSCF3036N6B*	G*E80704B**	18,000	13,100	14.00	12.20	16,700	13,000	16,800	8.00	8,600	3160486
	CSCF3036N6B*	G*V80704B**	18,000	13,100	14.00	12.20	16,700	13,000	16,800	8.00	8,600	3160487
CSCF3036N6B*	G*V950453B**	18,000	13,100	13.50	11.80	16,700	13,000	16,800	7.70	8,600	3160488	
CSCF3036N6B*+EEP		18,000	13,100	13.00	11.50	16,700	13,000	16,800	7.70	8,600	3160489	

See Notes on Page 44.

ARI PERFORMANCE RATINGS (CONT.)

Outdoor Unit	Indoor Units		Cooling (BTU/h)				TVA Ratings		Heating (BTU/h)			ARI #
	Indoor Coil	Furnace/ Blower	Total	Sens.	SEER ¹	EER ²	Total	Sens.	High	HSPF ³	Low	
	CT*F1824*6A*	G*E80704B**	18,000	13,100	14.00	12.20	16,700	13,000	16,800	8.00	8,600	3160490
	CT*F1824*6A*	G*V80704B**	18,000	13,100	14.00	12.20	16,700	13,000	16,800	8.00	8,600	3160491
	CT*F1824*6A*	G*V950453B**	18,000	13,100	13.50	11.80	16,700	13,000	16,800	7.70	8,600	3160492
	CT*F1824*6A*+EEP		18,000	13,100	13.00	11.50	16,700	13,000	16,800	7.70	8,600	3160493
	CT*F1824*6A*	MBE1200**-1	18,000	13,100	14.00	12.20	16,700	13,000	16,800	8.00	8,600	3160494
GSH13 0191A*	AC30-XX		18,000	13,500	13.00	11.50	16,700	13,400	16,800	7.70	8,600	735878
	ACNF24XX16A*		18,000	13,500	13.00	11.50	16,700	13,400	16,800	7.7	8,600	3001430
	ACNF24XX1A*		18,000	13,500	13.00	11.50	16,700	13,400	16,800	7.70	8,600	735867
	AR*F182416B*		18,400	13,800	13.00	11.50	17,000	13,600	17,000	8.00	8,800	1443967
	ARPF182416A*		18,400	13,800	13.00	11.50	17,000	13,600	17,000	8.00	8,800	1038047
	ARPF18241A*		18,400	13,800	13.00	11.50	17,000	13,600	17,000	8.00	8,800	1038048
	ARPF18241B*		18,400	13,800	13.00	11.50	17,000	13,600	17,000	8.00	8,800	1069214
	ARUF032-00*-1*		18,400	13,800	13.00	11.50	17,000	13,600	17,000	8.00	8,800	877504
	ARUF182416A*		18,400	13,800	13.00	11.50	17,000	13,600	17,000	8.00	8,800	1038046
	ARUF18241A*		18,400	13,800	13.00	11.50	17,000	13,600	17,000	8.00	8,800	877505
	ARUF18241B*		18,400	13,800	13.00	11.50	17,000	13,600	17,000	8.00	8,800	1069215
	ASPF183016A*		18,000	13,500	13.00	11.50	16,700	13,400	17,000	8.00	8,800	1291689
	ASPF183016B*		18,000	13,500	13.00	11.50	16,700	13,400	17,000	8.00	8,800	1492543
	AT*F182416A*		18,400	13,800	13.00	11.50	17,000	13,600	17,000	8.00	8,800	1483525
	AWB24-XX		18,000	13,500	13.00	11.50	16,700	13,400	16,800	7.80	8,600	735915
	AWUF18XX16A*		18,000	13,500	13.00	11.50	16,700	13,400	16,800	7.80	8,600	3001431
	AWUF18XX1A*		18,000	13,500	13.00	11.50	16,700	13,400	16,800	7.80	8,600	735876
	AWUF18XX1B*		18,000	13,500	13.00	11.50	16,700	13,400	16,800	7.80	8,600	1279577
	AWUF24XX16A*		18,000	13,500	13.00	11.50	16,700	13,400	16,800	7.80	8,600	3001432
	AWUF24XX1A*		18,000	13,500	13.00	11.50	16,700	13,400	16,800	7.80	8,600	1386298
AWUF24XX1B*		18,000	13,500	13.00	11.50	16,700	13,400	16,800	7.80	8,600	1386299	
GSH13 0241A*	ADPF182416A*		23,000	17,000	13.00	11.50	21,300	16,800	22,000	7.70	12,000	1038049
	ADPF182416B*		23,000	17,000	13.00	11.50	21,300	16,800	22,000	7.70	12,000	1443951
	ADPF18241A*		23,000	17,000	13.00	11.50	21,300	16,800	22,000	7.70	12,000	735981
	ADPF18241B*		23,000	17,000	13.00	11.50	21,300	16,800	22,000	7.70	12,000	1069216
	AEPF183016A*		23,000	17,000	14.00	12.20	21,300	16,800	22,000	8.00	12,000	1038050
	AEPF183016B*		23,000	17,000	14.00	12.20	21,300	16,800	22,000	8.00	12,000	1277841
	AEPF183016C*		23,000	17,000	14.00	12.20	21,300	16,800	22,000	8.00	12,000	1492544
	AEPF18301A*		23,000	17,000	14.00	12.20	21,300	16,800	22,000	8.00	12,000	735175
	AEPF18301B*		23,000	17,000	14.00	12.20	21,300	16,800	22,000	8.00	12,000	1069217
	AEPF303616A*		23,400	17,300	14.00	12.20	21,600	17,100	22,000	8.00	12,000	1069243
	AEPF303616B*		23,400	17,300	14.00	12.20	21,600	17,100	22,000	8.00	12,000	1277842
	AEPF303616C*		23,400	17,300	14.00	12.20	21,600	17,100	22,000	8.00	12,000	1443954
	AEPT030-00*-1*		23,000	17,000	14.00	12.20	21,300	16,800	22,000	8.00	12,000	735243
	AR*F182416B*		23,000	17,000	13.00	11.50	21,300	16,800	22,000	7.70	12,000	1443968
	ARPF036-00B-1*		23,000	17,000	13.00	11.50	21,300	16,800	22,000	7.70	12,000	735044
	ARPF182416A*		23,000	17,000	13.00	11.50	21,300	16,800	22,000	7.70	12,000	1038051
	ARPF18241A*		23,000	17,000	13.00	11.50	21,300	16,800	22,000	7.70	12,000	735240
	ARPF18241B*		23,000	17,000	13.00	11.50	21,300	16,800	22,000	7.70	12,000	1069218
	ARPT032-00*-1*		23,000	17,000	13.00	11.50	21,300	16,800	22,000	7.70	12,000	735248
	ARUF032-00*-1*		23,000	17,000	13.00	11.50	21,300	16,800	22,000	7.70	12,000	735045
	ARUF182416A*		23,000	17,000	13.00	11.50	21,300	16,800	22,000	7.70	12,000	1038052
	ARUF18241A*		23,000	17,000	13.00	11.50	21,300	16,800	22,000	7.70	12,000	735204
	ARUF18241B*		23,000	17,000	13.00	11.50	21,300	16,800	22,000	7.70	12,000	1069219
	ASPF183016A*		23,000	17,000	14.00	12.20	21,300	16,800	22,000	8.20	12,000	1291678

See Notes on Page 44.

ARI PERFORMANCE RATINGS (CONT.)

Outdoor Unit	Indoor Units		Cooling (BTU/h)				TVA Ratings		Heating (BTU/h)			ARI #
	Indoor Coil	Furnace/ Blower	Total	Sens.	SEER ¹	EER ²	Total	Sens.	High	HSPF ³	Low	
GSH13 0241A* (cont.)	ASPF183016B*		23,000	17,000	14.00	12.20	21,300	16,800	22,000	8.20	12,000	1492545
	ASPF303616A*		23,400	17,300	14.00	12.20	21,600	17,100	22,000	8.00	12,000	1291691
	ASPF303616B*		23,400	17,300	14.00	12.20	21,600	17,100	22,000	8.00	12,000	1443978
	AT*F182416A*		23,000	17,000	13.00	11.50	21,300	16,800	22,000	7.70	12,000	1483526
	AWB36-XX		23,000	17,000	13.00	11.50	21,300	16,800	22,000	7.70	12,000	735063
	AWUF30XX16A*		23,000	17,000	13.00	11.50	21,300	16,800	22,000	7.70	12,000	3001433
	AWUF30XX1A*		23,000	17,000	13.00	11.50	21,300	16,800	22,000	7.70	12,000	1330438
	AWUF36XX16A*		23,000	17,000	13.00	11.50	21,300	16,800	22,000	7.70	12,000	3001434
	AWUF36XX1A*		23,000	17,000	13.00	11.50	21,300	16,800	22,000	7.70	12,000	735253
	CA*F030*2*	MBE1200**-1	23,000	17,000	14.00	12.20	21,300	16,800	22,000	8.00	12,000	1032338
	CA*F037*2*	G*V80704B**	23,000	17,000	13.00	11.50	21,300	16,800	22,000	7.70	12,000	735166
	CA*F037*2*	G*V950453B**	23,000	17,000	13.00	11.80	21,300	16,800	22,000	7.70	12,000	735815
	CA*F037*2*+EFP		23,000	17,000	13.00	11.50	21,300	16,800	22,000	7.70	12,000	735039
	CA*F1824*6A*	MBE1200**-1	23,000	17,000	14.00	12.20	21,300	16,800	22,000	8.00	12,000	1032330
	CA*F1824*6B*	MBE1200**-1	23,000	17,000	14.00	12.20	21,300	16,800	22,000	8.00	12,000	1346678
	CA*F1824*6C*	MBE1200**-1	23,000	17,000	14.00	12.20	21,300	16,800	22,000	8.00	12,000	1386237
	CA*F3030*6A*	G*E80704B**	23,000	17,000	14.00	12.20	21,300	16,800	22,000	7.70	12,000	1273329
	CA*F3030*6A*	G*V80704B**	23,000	17,000	13.00	11.50	21,300	16,800	22,000	7.70	12,000	735093
	CA*F3030*6A*	G*V950453B**	23,000	17,000	13.00	11.80	21,300	16,800	22,000	7.70	12,000	735984
	CA*F3030*6A*+EFP		23,000	17,000	13.00	11.50	21,300	16,800	22,000	7.70	12,000	735188
	CA*F3030*6B*	G*E80704B**	23,000	17,000	14.00	12.20	21,300	16,800	22,000	7.70	12,000	1347189
	CA*F3030*6B*	G*V80704B**	23,000	17,000	13.00	11.50	21,300	16,800	22,000	7.70	12,000	1347190
	CA*F3030*6B*	G*V950453B**	23,000	17,000	13.00	11.80	21,300	16,800	22,000	7.70	12,000	1347191
	CA*F3030*6B*+EFP		23,000	17,000	13.00	11.50	21,300	16,800	22,000	7.70	12,000	1347192
	CHPF030A2*+EFP		23,000	17,000	13.00	11.50	21,300	16,800	22,000	7.70	12,000	735838
	CHPF042B2*	G*V80704B**	23,000	17,000	13.00	11.50	21,300	16,800	22,000	7.70	12,000	735226
	CHPF042B2*	G*V950453B**	23,000	17,000	13.50	11.80	21,300	16,800	22,000	7.70	12,000	735818
	CHPF1824A6A*+EFP		23,000	17,000	13.00	11.50	21,300	16,800	22,000	7.70	12,000	735847
	CHPF2430B6A*	G*E80704B**	23,000	17,000	14.00	12.20	21,300	16,800	22,000	7.70	12,000	1273330
	CHPF2430B6A*	G*V80704B**	23,000	17,000	13.00	11.50	21,300	16,800	22,000	7.70	12,000	735147
	CHPF2430B6A*	G*V950453B**	23,000	17,000	13.50	11.80	21,300	16,800	22,000	7.70	12,000	735826
	CHPF2430B6B*	G*E80704B**	23,000	17,000	14.00	12.20	21,300	16,800	22,000	7.70	12,000	1347583
	CHPF2430B6B*	G*V80704B**	23,000	17,000	13.00	11.50	21,300	16,800	22,000	7.70	12,000	1330386
	CHPF2430B6B*	G*V950453B**	23,000	17,000	13.50	11.80	21,300	16,800	22,000	7.70	12,000	1330387
	CHPF2430B6B*+EFP		23,000	17,000	13.00	11.50	21,300	16,800	22,000	7.70	12,000	1330385
	CSCF1824N6A*	G*E80704B**	23,000	17,000	14.00	12.20	21,300	16,800	22,000	7.70	12,000	1273331
	CSCF1824N6A*	G*V80704B**	23,000	17,000	13.00	11.50	21,300	16,800	22,000	7.70	12,000	735152
	CSCF1824N6A*	G*V950453B**	23,000	17,000	13.50	11.80	21,300	16,800	22,000	7.70	12,000	735809
	CSCF1824N6A*+EFP		23,000	17,000	13.00	11.50	21,300	16,800	22,000	7.70	12,000	735112
	CSCF3036N6B*	G*E80704B**	23,000	17,000	14.00	12.20	21,300	16,800	22,000	7.70	12,000	1347351
	CSCF3036N6B*	G*V80704B**	23,000	17,000	13.00	11.50	21,300	16,800	22,000	7.70	12,000	1296612
	CSCF3036N6B*	G*V950453B**	23,000	17,000	13.50	11.80	21,300	16,800	22,000	7.70	12,000	1296613
	CSCF3036N6B*+EFP		23,000	17,000	13.00	11.50	21,300	16,800	22,000	7.70	12,000	1296614
	CT*F1824*6A*	MBE1200**-1	23,000	17,000	14.00	12.20	21,300	16,800	22,000	8.00	12,000	1449924
	CT*F3030*6A*	G*E80704B**	23,000	17,000	14.00	12.20	21,300	16,800	22,000	7.70	12,000	1449925
	CT*F3030*6A*	G*V80704B**	23,000	17,000	13.00	11.50	21,300	16,800	22,000	7.70	12,000	1449926
	CT*F3030*6A*	G*V950453B**	23,000	17,000	13.00	11.80	21,300	16,800	22,000	7.70	12,000	1449927
	CT*F3030*6A*+EFP		23,000	17,000	13.00	11.50	21,300	16,800	22,000	7.70	12,000	1449928
	H36F	G*V80704B**	23,000	17,000	13.00	11.50	21,300	16,800	22,000	7.70	12,000	735211
	H36F	G*V950453B**	23,000	17,000	13.50	11.80	21,300	16,800	22,000	7.70	12,000	735821
H36F+EFP		23,000	17,000	13.00	11.50	21,300	16,800	22,000	7.70	12,000	735252	

See Notes on Page 44.

ARI PERFORMANCE RATINGS (CONT.)

Outdoor Unit	Indoor Units		Cooling (BTU/h)				TVA Ratings		Heating (BTU/h)			ARI #
	Indoor Coil	Furnace/ Blower	Total	Sens.	SEER ¹	EER ²	Total	Sens.	High	HSPF ³	Low	
GSH13 0241B*	ADPF182416A*		23,000	17,000	13.00	11.50	21,300	16,800	22,000	7.70	12,000	3160495
	ADPF182416B*		23,000	17,000	13.00	11.50	21,300	16,800	22,000	7.70	12,000	3160496
	AEPF183016B*		23,000	17,000	14.00	12.20	21,300	16,800	22,000	8.00	12,000	3160497
	AEPF183016C*		23,000	17,000	14.00	12.20	21,300	16,800	22,000	8.00	12,000	3160498
	AEPF303616A*		23,400	17,300	14.00	12.20	21,300	17,100	22,000	8.00	12,000	3160499
	AEPF303616B*		23,400	17,300	14.00	12.20	21,300	17,100	22,000	8.00	12,000	3160500
	AEPF303616C*		23,400	17,300	14.00	12.20	21,300	17,100	22,000	8.00	12,000	3160501
	AR*F182416B*		23,000	17,000	13.00	11.50	21,300	16,800	22,000	7.70	12,000	3160502
	AR*F182416A*		23,000	17,000	13.00	11.50	21,300	16,800	22,000	7.70	12,000	3160503
	ASPF183016A*		23,000	17,000	14.00	12.20	21,600	16,800	22,000	8.20	12,000	3160504
	ASPF183016B*		23,000	17,000	14.00	12.20	21,600	16,800	22,000	8.20	12,000	3160505
	ASPF303616A*		23,400	17,300	14.00	12.20	21,600	17,100	22,000	8.00	12,000	3160506
	ASPF303616B*		23,400	17,300	14.00	12.20	21,300	17,100	22,000	8.00	12,000	3160507
	AT*F182416A*		23,000	17,000	13.00	11.50	21,300	16,800	22,000	7.70	12,000	3160508
	AWUF30XX16A*		23,000	17,000	13.00	11.50	21,300	16,800	22,000	7.70	12,000	3160509
	AWUF36XX16A*		23,000	17,000	13.00	11.50	21,300	16,800	22,000	7.70	12,000	3160510
	CA*F1824*6B*	MBE1200**-1	23,000	17,000	14.00	12.20	21,300	16,800	22,000	8.00	12,000	3160511
	CA*F1824*6C*	MBE1200**-1	23,000	17,000	14.00	12.20	21,300	16,800	22,000	8.00	12,000	3160512
	CA*F3030*6B*	G*E80704B**	23,000	17,000	14.00	12.20	21,300	16,800	22,000	7.70	12,000	3160513
	CA*F3030*6B*	G*V80704B**	23,000	17,000	13.00	11.50	21,300	16,800	22,000	7.70	12,000	3160514
	CA*F3030*6B*	G*V950453B**	23,000	17,000	13.00	11.80	21,300	16,800	22,000	7.70	12,000	3160515
	CA*F3030*6B*+EEP		23,000	17,000	13.00	11.50	21,300	16,800	22,000	7.70	12,000	3160516
	CHPF2430B6B*	G*E80704B**	23,000	17,000	14.00	12.20	21,300	16,800	22,000	7.70	12,000	3160517
	CHPF2430B6B*	G*V80704B**	23,000	17,000	13.00	11.50	21,300	16,800	22,000	7.70	12,000	3160518
	CHPF2430B6B*	G*V950453B**	23,000	17,000	13.50	11.80	21,300	16,800	22,000	7.70	12,000	3160519
	CHPF2430B6B*+EEP		23,000	17,300	13.00	11.50	21,600	16,800	22,000	7.70	12,000	3160520
	CSCF3036N6B*	G*E80704B**	23,000	17,300	14.00	12.20	21,600	16,800	22,000	7.70	12,000	3160521
	CSCF3036N6B*	G*V80704B**	23,000	17,000	13.00	11.50	21,300	16,800	22,000	7.70	12,000	3160522
	CSCF3036N6B*	G*V950453B**	23,000	17,000	13.50	11.80	21,300	16,800	22,000	7.70	12,000	3160523
	CSCF3036N6B*+EEP		23,000	17,000	13.00	11.50	21,300	16,800	22,000	7.70	12,000	3160524
CT*F1824*6A*	MBE1200**-1	23,000	17,000	14.00	12.20	21,300	16,800	22,000	8.00	12,000	3160525	
CT*F3030*6A*	G*E80704B**	23,000	17,000	14.00	12.20	21,300	16,800	22,000	7.70	12,000	3160526	
CT*F3030*6A*	G*V80704B**	23,000	17,000	13.00	11.50	21,300	16,800	22,000	7.70	12,000	3160527	
CT*F3030*6A*	G*V950453B**	23,000	17,000	13.00	11.80	21,300	16,800	22,000	7.70	12,000	3160528	
CT*F3030*6A*+EEP		23,000	17,000	13.00	11.50	21,300	16,800	22,000	7.70	12,000	3160529	
GSH13 0251A*	AC30-XX		23,600	17,500	13.00	11.50	21,800	17,200	22,600	7.70	12,400	735208
	ACNF24XX16A*		23,600	17,500	13.00	11.50	21,800	17,200	22,600	7.70	12,400	3001435
	ACNF24XX1A*		23,600	17,500	13.00	11.50	21,800	17,200	22,600	7.70	12,400	735217
	AR*F182416B*		24,000	17,800	13.00	11.50	22,200	17,500	22,600	8.00	12,400	1443969
	ARPF182416A*		24,000	17,800	13.00	11.50	22,200	17,500	22,600	8.00	12,400	1038054
	ARPF18241A*		24,000	17,800	13.00	11.50	22,200	17,500	22,600	8.00	12,400	1038055
	ARPF18241B*		24,000	17,800	13.00	11.50	22,200	17,500	22,600	8.00	12,400	1069220
	ARUF032-00*-1*		24,000	17,800	13.00	11.50	22,200	17,500	22,600	8.00	12,400	877503
	ARUF182416A*		24,000	17,800	13.00	11.50	22,200	17,500	22,600	8.00	12,400	1038053
	ARUF18241A*		24,000	17,800	13.00	11.50	22,200	17,500	22,600	8.00	12,400	877506
	ARUF18241B*		24,000	17,800	13.00	11.50	22,200	17,500	22,600	8.00	12,400	1069221
	ASPF183016A*		23,000	17,000	14.00	12.20	21,300	16,800	22,000	8.00	12,000	1291690
	ASPF183016B*		23,000	17,000	14.00	12.20	21,300	16,800	22,000	8.00	12,000	1492546
	ASPF303616A*		23,400	17,300	14.00	12.20	21,600	17,100	23,600	7.80	12,400	1291794
	ASPF303616B*		23,400	17,300	14.00	12.20	21,600	17,100	23,600	7.80	12,400	1443979

See Notes on Page 50.

ARI PERFORMANCE RATINGS (CONT.)

Outdoor Unit	Indoor Units		Cooling (BTU/h)				TVA Ratings		Heating (BTU/h)			ARI #
	Indoor Coil	Furnace/ Blower	Total	Sens.	SEER ¹	EER ²	Total	Sens.	High	HSPF ³	Low	
GSH13 0301A*	AT*F182416A*		24,000	17,800	13.00	11.50	22,200	17,500	22,600	8.00	12,400	1483527
	AWB24-XX		23,400	17,300	13.00	11.50	21,600	17,100	22,600	7.80	12,400	735036
	AWB36-XX		24,000	17,800	13.00	11.50	22,200	17,500	22,600	7.80	12,400	735040
	AWUF24XX16A*		23,000	17,000	13.00	11.50	21,300	16,800	22,600	7.80	12,400	3001436
	AWUF24XX1A*		23,400	17,300	13.00	11.50	21,600	17,100	23,600	7.80	12,400	735231
	AWUF24XX1B*		23,400	17,300	13.00	11.50	21,600	17,100	23,600	7.80	12,400	1279599
	AWUF30XX16A*		23,600	17,500	13.00	11.50	21,800	17,200	22,600	7.80	12,400	3001437
	AWUF30XX1A*		24,000	17,800	13.00	11.50	22,200	17,500	22,600	7.80	12,400	1330439
	AWUF36XX16A*		23,600	17,500	13.00	11.50	21,800	17,200	22,600	7.80	12,400	3001438
	AWUF36XX1A*		24,000	17,800	13.00	11.50	22,200	17,500	22,600	7.80	12,400	735238
	ADPF304216A*		28,000	21,000	13.00	11.50	25,900	20,700	26,800	7.70	14,000	1038056
	ADPF304216B*		28,000	21,000	13.00	11.50	25,900	20,700	26,800	7.70	14,000	1492547
	ADPF30421A*		28,000	21,000	13.00	11.50	25,900	20,700	26,800	7.70	14,000	735259
	ADPF30421B*		28,000	21,000	13.00	11.50	25,900	20,700	26,800	7.70	14,000	1069222
	AEPF183016A*		28,000	21,000	14.00	12.20	25,900	20,700	26,800	8.00	14,000	1038057
	AEPF183016B*		28,000	21,000	14.00	12.20	25,900	20,700	26,800	8.00	14,000	1277843
	AEPF183016C*		28,000	21,000	14.00	12.20	25,900	20,700	26,800	8.00	14,000	1492548
	AEPF18301A*		28,000	21,000	14.00	12.20	25,900	20,700	26,800	8.00	14,000	735151
	AEPF18301B*		28,000	21,000	14.00	12.20	25,900	20,700	26,800	8.00	14,000	1069226
	AEPF303616B*		29,000	21,800	14.00	12.20	26,800	21,400	26,800	8.00	14,000	1444037
	AEPF303616C*		29,000	21,800	14.00	12.20	26,800	21,400	26,800	8.00	14,000	1486998
	AEPT030-00*-1*		28,000	21,000	14.00	12.20	25,900	20,700	26,800	8.00	14,000	735082
	AEPT036-00*-1*		29,000	21,800	14.00	12.20	26,800	21,400	26,800	8.00	14,000	1083284
	AR*F032-00*-1*+TXV		27,800	20,900	13.00	11.50	25,700	20,600	26,600	7.70	14,000	1347614
	AR*F18241**+TXV		27,800	20,900	13.00	11.50	25,700	20,600	26,600	7.70	14,000	1206583
	AR*F182416B*+TXV		27,800	20,900	13.00	11.50	25,700	20,600	26,600	7.70	14,000	1443972
	AR*F303016B*		28,000	21,000	13.00	11.50	25,900	20,700	26,800	7.70	14,000	1492549
	ARPF048-00B-1*		28,000	21,000	13.00	11.50	25,900	20,700	26,800	7.70	14,000	735090
	ARPF303016A*		28,000	21,000	13.00	11.50	25,900	20,700	26,800	7.70	14,000	1038058
	ARPF30301A*		28,000	21,000	13.00	11.50	25,900	20,700	26,800	7.70	14,000	735087
	ARPF30301B*		28,000	21,000	13.00	11.50	25,900	20,700	26,800	7.70	14,000	1069224
	ARPT042-00*-1*		28,000	21,000	13.00	11.50	25,900	20,700	26,800	7.70	14,000	735222
	ARUF042-00*-1*		28,000	21,000	13.00	11.50	25,900	20,700	26,800	7.70	14,000	735108
	ARUF303016A*		28,000	21,000	13.00	11.50	25,900	20,700	26,800	7.70	14,000	1038059
	ARUF30301A*		28,000	21,000	13.00	11.50	25,900	20,700	26,800	7.70	14,000	735228
	ARUF30301B*		28,000	21,000	13.00	11.50	25,900	20,700	26,800	7.70	14,000	1069225
	ASPF183016A*		28,000	21,000	14.00	12.20	25,900	20,700	26,800	8.00	14,000	1291679
	ASPF183016B*		28,000	21,000	14.00	12.20	25,900	20,700	26,800	8.00	14,000	1492550
	ASPF303616A*		28,400	21,300	14.00	12.20	26,300	21,000	26,800	8.00	14,000	1291884
	ASPF303616B*		28,400	21,300	14.00	12.20	26,300	21,000	26,800	8.00	14,000	1443980
	AT*F303016A*		28,000	21,000	13.00	11.50	25,900	20,700	26,800	7.70	14,000	1483528
	AWUF37XX16A*		28,400	21,300	13.00	11.50	26,300	21,000	25,000	7.80	15,000	3001439
AWUF37XX1A*		28,400	21,300	13.00	11.50	26,300	21,000	25,000	7.80	15,000	1505957	
CA*F042*2*	G*V80704B**	28,000	21,000	14.00	12.20	25,900	20,700	26,800	8.00	14,000	735189	
CA*F042*2*	G*V90703B**	28,000	21,000	13.50	11.80	25,900	20,700	26,800	7.70	14,000	735824	
CA*F042*2*	G*V950453B**	28,000	21,000	13.50	11.80	25,900	20,700	26,800	7.70	14,000	735823	
CA*F042*2*+EEP		28,000	21,000	13.00	11.50	25,900	20,700	26,800	7.70	14,000	735841	
CA*F042*2*	MBE1200**-1	28,000	21,000	14.00	12.20	25,900	20,700	26,800	8.00	14,000	1032325	
CA*F3131*6A*	G*V80704B**	28,000	21,000	14.00	12.20	25,900	20,700	26,800	8.00	14,000	736494	
CA*F3131*6A*	G*V90703B**	28,000	21,000	13.50	11.80	25,900	20,700	26,800	7.70	14,000	736495	

See Notes on Page 50.

ARI PERFORMANCE RATINGS (CONT.)

Outdoor Unit	Indoor Units		Cooling (BTU/h)				TVA Ratings		Heating (BTU/h)			ARI #
	Indoor Coil	Furnace/ Blower	Total	Sens.	SEER ¹	EER ²	Total	Sens.	High	HSPF ³	Low	
GSH13 0301A* (cont.)	CA*F3131*6A*	G*V950453B**	28,000	21,000	13.50	11.80	25,900	20,700	26,800	7.70	14,000	736496
	CA*F3131*6A*	G*V950704C**	28,000	21,000	13.50	11.80	25,900	20,700	26,800	7.80	14,000	1038079
	CA*F3131*6A*+EEP		28,000	21,000	13.00	11.50	25,900	20,700	26,800	7.70	14,000	735812
	CA*F3131*6A*	MBE1200**-1	28,000	21,000	13.50	11.80	25,900	20,700	26,800	7.80	14,000	1032298
	CA*F3131*6A*+TXV	MBE1200**-1	28,000	21,000	14.00	12.20	25,900	20,700	26,800	8.00	14,000	1386300
	CA*F3131*6B*	G*V80704B**	28,000	21,000	14.00	12.20	25,900	20,700	26,800	8.00	14,000	1348594
	CA*F3131*6B*	G*V90703B**	28,000	21,000	13.50	11.80	25,900	20,700	26,800	7.70	14,000	1347194
	CA*F3131*6B*	G*V950453B**	28,000	21,000	13.50	11.80	25,900	20,700	26,800	7.70	14,000	1347195
	CA*F3131*6B*	G*V950704C**	28,000	21,000	13.50	11.80	25,900	20,700	26,800	7.80	14,000	1347193
	CA*F3131*6B*	G*V950704C**	28,000	21,000	13.50	11.80	25,900	20,700	26,800	7.80	14,000	1347196
	CA*F3131*6B*+EEP		28,000	21,000	13.00	11.50	25,900	20,700	26,800	7.70	14,000	1347197
	CA*F3131*6B*	MBE1200**-1	28,000	21,000	13.50	11.80	25,900	20,700	26,800	7.80	14,000	1346679
	CA*F3131*6C*	G*V80704B**	28,000	21,000	14.00	12.20	25,900	20,700	26,800	8.00	14,000	1401062
	CA*F3131*6C*	G*V90703B**	28,000	21,000	13.50	11.80	25,900	20,700	26,800	7.70	14,000	1386238
	CA*F3131*6C*	G*V950704C**	28,000	21,000	13.50	11.80	25,900	20,700	26,800	7.80	14,000	1386239
	CA*F3131*6C*+EEP		28,000	21,000	13.00	11.50	25,900	20,700	26,800	7.70	14,000	1386240
	CA*F3131*6C*	MBE1200**-1	28,000	21,000	13.50	11.80	25,900	20,700	26,800	7.80	14,000	1386242
	CA*F3636*6A*	G*E80704B**	28,000	21,000	14.00	12.20	25,900	20,700	26,800	8.00	14,000	1273332
	CA*F3636*6B*	G*E80704B**	28,000	21,000	14.00	12.20	25,900	20,700	26,800	8.00	14,000	1347198
	CHPF042B2*	G*V80704B**	28,000	21,000	14.00	12.20	25,900	20,700	26,800	8.00	14,000	735106
	CHPF042B2*	G*V90704C**	28,000	21,000	13.50	11.80	25,900	20,700	26,800	7.70	14,000	735219
	CHPF042B2*	G*V950704C**	28,000	21,000	13.50	11.80	25,900	20,700	26,800	7.70	14,000	735817
	CHPF042B2*+EEP		28,000	21,000	13.00	11.50	25,900	20,700	26,800	7.70	14,000	735834
	CHPF2430B6A*	G*V80704B**	28,000	21,000	14.00	12.20	25,900	20,700	26,800	8.00	14,000	735254
	CHPF2430B6A*	G*V90704C**	28,000	21,000	13.50	11.80	25,900	20,700	26,800	7.70	14,000	735079
	CHPF2430B6A*	G*V950704C**	28,000	21,000	13.50	11.80	25,900	20,700	26,800	7.70	14,000	735819
	CHPF2430B6A*+EEP		28,000	21,000	13.00	11.50	25,900	20,700	26,800	7.70	14,000	735808
	CHPF2430B6B*	G*V80704B**	28,000	21,000	14.00	12.20	25,900	20,700	26,800	8.00	14,000	1348595
	CHPF2430B6B*	G*V90704C**	28,000	21,000	13.50	11.80	25,900	20,700	26,800	7.70	14,000	1330389
	CHPF2430B6B*	G*V950704C**	28,000	21,000	13.50	11.80	25,900	20,700	26,800	7.70	14,000	1330388
	CHPF2430B6B*	G*V950704C**	28,000	21,000	13.50	11.80	25,900	20,700	26,800	7.70	14,000	1330390
	CHPF2430B6B*+EEP		28,000	21,000	13.00	11.50	25,900	20,700	26,800	7.70	14,000	1330391
	CHPF3636B6A*	G*E80704B**	28,000	21,000	14.00	12.20	25,900	20,700	26,800	8.00	14,000	1273333
	CSCF3036N6A*	G*V80704B**	28,000	21,000	14.00	12.20	25,900	20,700	26,800	8.00	14,000	735201
	CSCF3036N6A*	G*V90704C**	28,000	21,000	13.50	11.80	25,900	20,700	26,800	7.70	14,000	735170
	CSCF3036N6A*	G*V950704C**	28,000	21,000	13.50	11.80	25,900	20,700	26,800	7.70	14,000	735835
	CSCF3036N6A*+EEP		28,000	21,000	13.00	11.50	25,900	20,700	26,800	7.70	14,000	735829
	CSCF3036N6B*	G*V80704B**	28,000	21,000	14.00	12.20	25,900	20,700	26,800	8.00	14,000	1348596
	CSCF3036N6B*	G*V90704C**	28,000	21,000	13.50	11.80	25,900	20,700	26,800	7.70	14,000	1296616
	CSCF3036N6B*	G*V950704C**	28,000	21,000	13.50	11.80	25,900	20,700	26,800	7.70	14,000	1296617
CSCF3036N6B*	G*V950704C**	28,000	21,000	13.50	11.80	25,900	20,700	26,800	7.70	14,000	1296615	
CSCF3036N6B*+EEP		28,000	21,000	13.00	11.50	25,900	20,700	26,800	7.70	14,000	1296618	
CSCF3642N6A*	G*E80704B**	28,000	21,000	14.00	12.20	25,900	20,700	26,800	8.00	14,000	1273334	
CSCF3642N6C*	G*E80704B**	28,000	21,000	14.00	12.20	25,900	20,700	26,800	8.00	14,000	1296585	
CT*F3131*6A*	G*V80704B**	28,000	21,000	14.00	12.20	25,900	20,700	26,800	8.00	14,000	1449929	

¹ Seasonal Energy Efficiency Ratio; Certified per ARI 210/240 @ 80°F/ 67°F/ 95°F

² Energy Efficiency Ratio @ 80°F/ 67°F/ 95°F

³ TVA Rating: BTU/h @ 75°F/ 63°F - 95°F

⁴ HSPF = Heating Seasonal Performance Factor

Notes:

- Always check the S&R plate for electrical data on the unit being installed.
- When matching the outdoor unit to the indoor unit, use the piston supplied with the outdoor unit or that specified on the piston kit chart supplied with the indoor unit.
- EEP - Order from Service Dept. Part No. B13707-38 or new Solid State Board B13707-35S. Part No. B13707-38 is not interchangeable with B13707-35S. The Goodman Gas Furnace contains the EEP cooling time delay

ARI PERFORMANCE RATINGS (CONT.)

Outdoor Unit	Indoor Units		Cooling (BTU/h)				TVA Ratings		Heating (BTU/h)			ARI #
	Indoor Coil	Furnace/ Blower	Total	Sens.	SEER ¹	EER ²	Total	Sens.	High	HSPF ³	Low	
GSH13 0301A* (cont.)	CT*F3131*6A*	G*V90703B**	28,000	21,000	13.50	11.80	25,900	20,700	26,800	7.70	14,000	1449930
	CT*F3131*6A*	G*V950453B**	28,000	21,000	13.50	11.80	25,900	20,700	26,800	7.70	14,000	1449931
	CT*F3131*6A*	G*V950704C**	28,000	21,000	13.50	11.80	25,900	20,700	26,800	7.80	14,000	1449932
	CT*F3131*6A*+EEP		28,000	21,000	13.00	11.50	25,900	20,700	26,800	7.70	14,000	1449933
	CT*F3131*6A*	MBE1200**-1	28,000	21,000	13.50	11.80	25,900	20,700	26,800	7.80	14,000	1449934
	CT*F3131*6A*+TXV	MBE1200**-1	28,000	21,000	14.00	12.20	25,900	20,700	26,800	8.00	14,000	1449935
	CT*F3636*6A*	G*E80704B**	28,000	21,000	14.00	12.20	25,900	20,700	26,800	8.00	14,000	1449936
	H49F	G*V80704B**	28,000	21,000	14.00	12.20	25,900	20,700	26,800	8.00	14,000	735041
	H49F	G*V90704C**	28,000	21,000	13.50	11.80	25,900	20,700	26,800	7.70	14,000	735215
	H49F	G*V950704C**	28,000	21,000	13.50	11.80	25,900	20,700	26,800	7.70	14,000	735836
	H49F+EEP		28,000	21,000	13.00	11.50	25,900	20,700	26,800	7.70	14,000	735804
GSH13 0301B*	ADPF304216A*		28,000	21,000	13.00	11.50	25,900	20,700	26,800	7.70	14,000	3160530
	ADPF304216B*		28,000	21,000	13.00	11.50	25,900	20,700	26,800	7.70	14,000	3160559
	AEPF183016B*		28,000	21,000	14.00	12.20	25,900	20,700	26,800	8.00	14,000	3160531
	AEPF183016C*		28,000	21,000	14.00	12.20	25,900	20,700	26,800	8.00	14,000	3160560
	AEPF303616B*		29,000	21,800	14.00	12.20	26,800	21,400	26,800	8.00	14,000	3160532
	AEPF303616C*		29,000	21,800	14.00	12.20	26,800	21,400	26,800	8.00	14,000	3160561
	AR*F182416B*+TXV		27,800	20,900	13.00	11.50	25,700	20,600	26,600	7.70	14,000	3160562
	ARPF303016A*		28,000	21,000	13.00	11.50	25,900	20,700	26,800	7.70	14,000	3160533
	AR*F303016B*		28,000	21,000	13.00	11.50	25,900	20,700	26,800	7.70	14,000	3160563
	ASPF183016A*		28,000	21,000	14.00	12.20	25,900	20,700	26,800	8.00	14,000	3160534
	ASPF183016B*		28,000	21,000	14.00	12.20	25,900	20,700	26,800	8.00	14,000	3160564
	ASPF303616A*		28,400	21,300	14.00	12.20	26,300	21,000	26,800	8.00	14,000	3160535
	ASPF303616B*		28,400	21,300	14.00	12.20	26,300	21,000	26,800	8.00	14,000	3160565
	AT*F303016A*		28,000	21,000	13.00	11.50	25,900	20,700	26,800	7.70	14,000	3160566
	AWUF37XX16A*		28,400	21,300	13.00	11.50	26,300	21,000	25,000	7.80	15,000	3160536
	CA*F3131*6C*	G*V950704C**	28,000	21,000	13.50	11.80	25,900	20,700	26,800	7.80	14,000	3160539
	CA*F3131*6C*	G*V90703B**	28,000	21,000	13.50	11.80	25,900	20,700	26,800	7.70	14,000	3160538
	CA*F3131*6C*	G*V80704B**	28,000	21,000	14.00	12.20	25,900	20,700	26,800	8.00	14,000	3160537
	CA*F3131*6C*+EEP		28,000	21,000	13.00	11.50	25,900	20,700	26,800	7.70	14,000	3160540
	CA*F3131*6C*	MBE1200**-1	28,000	21,000	13.50	11.80	25,900	20,700	26,800	7.80	14,000	3160541
	CA*F3636*6B*	G*E80704B**	28,000	21,000	14.00	12.20	25,900	20,700	26,800	8.00	14,000	3160567
	CHPF2430B6B*	G*V80704B**	28,000	21,000	14.00	12.20	25,900	20,700	26,800	8.00	14,000	3160542
	CHPF2430B6B*	G*V90704C**	28,000	21,000	13.50	11.80	25,900	20,700	26,800	7.70	14,000	3160543
	CHPF2430B6B*	G*V950704C**	28,000	21,000	13.50	11.80	25,900	20,700	26,800	7.70	14,000	3160544
	CHPF2430B6B*+EEP		28,000	21,000	13.00	11.50	25,900	20,700	26,800	7.70	14,000	3160545
	CSCF3036N6B*	G*V80704B**	28,000	21,000	14.00	12.20	25,900	20,700	26,800	8.00	14,000	3160546
	CSCF3036N6B*	G*V90704C**	28,000	21,000	13.50	11.80	25,900	20,700	26,800	7.70	14,000	3160547
	CSCF3036N6B*	G*V950704C**	28,000	21,000	13.50	11.80	25,900	20,700	26,800	7.70	14,000	3160548
	CSCF3036N6B*+EEP		28,000	21,000	13.00	11.50	25,900	20,700	26,800	7.70	14,000	3160568
	CSCF3642N6A*	G*E80704B**	28,000	21,000	14.00	12.20	25,900	20,700	26,800	8.00	14,000	3160549
	CSCF3642N6C*	G*E80704B**	28,000	21,000	14.00	12.20	25,900	20,700	26,800	8.00	14,000	3160550
	CT*F3131*6C*	G*V80704B**	28,000	21,000	14.00	12.20	25,900	20,700	26,800	8.00	14,000	3160551
	CT*F3131*6C*	G*V950453B**	28,000	21,000	13.50	11.80	25,900	20,700	26,800	7.70	14,000	3160553
	CT*F3131*6C*	G*V90703B**	28,000	21,000	13.50	11.80	25,900	20,700	26,800	7.70	14,000	3160552
	CT*F3131*6C*	G*V950704C**	28,000	21,000	13.50	11.80	25,900	20,700	26,800	7.80	14,000	3160554
	CT*F3131*6A*+EEP		28,000	21,000	13.00	11.50	25,900	20,700	26,800	7.70	14,000	3160555
	CT*F3131*6A*	MBE1200**-1	28,000	21,000	13.50	11.80	25,900	20,700	26,800	7.80	14,000	3160556
	CT*F3131*6A*+TXV	MBE1200**-1	28,000	21,000	14.00	12.20	25,900	20,700	26,800	8.00	14,000	3160557
	CT*F3636*6A*	G*E80704B**	28,000	21,000	14.00	12.20	25,900	20,700	26,800	8.00	14,000	3160558

See Notes on Page 50.

ARI PERFORMANCE RATINGS (CONT.)

Outdoor Unit	Indoor Units		Cooling (BTU/h)				TVA Ratings		Heating (BTU/h)			ARI #
	Indoor Coil	Furnace/ Blower	Total	Sens.	SEER ¹	EER ²	Total	Sens.	High	HSPF ³	Low	
GSH13 0311A*	AC36-XX		27,000	21,100	13.00	11.50	25,000	20,800	25,600	7.70	14,000	735095
	ACNF30XX16A*		27,000	21,100	13.00	11.50	25,000	20,800	25,600	7.70	14,000	3001440
	ACNF30XX1A*		27,000	21,100	13.00	11.50	25,000	20,800	25,600	7.70	14,000	735800
	AR*F303016B*		28,000	21,800	13.00	11.50	25,900	21,500	26,000	8.00	15,000	1492551
	ARPF303016A*		28,000	21,800	13.00	11.50	25,900	21,500	26,000	8.00	15,000	1038061
	ARPF30301A*		28,000	21,800	13.00	11.50	25,900	21,500	26,000	8.00	15,000	1038062
	ARPF30301B*		28,000	21,800	13.00	11.50	25,900	21,500	26,000	8.00	15,000	1069223
	ARUF042-00*-1*		28,000	21,800	13.00	11.50	25,900	21,500	26,000	8.00	15,000	1032341
	ARUF303016A*		28,000	21,800	13.00	11.50	25,900	21,500	26,000	8.00	15,000	1038060
	ARUF30301A*		28,000	21,800	13.00	11.50	25,900	21,500	26,000	8.00	15,000	1032340
	ARUF30301B*		28,000	21,800	13.00	11.50	25,900	21,500	26,000	8.00	15,000	1069205
	ASPF183016A*		28,000	21,800	14.00	12.20	25,900	21,500	26,800	8.00	14,000	1291692
	ASPF183016B*		28,000	21,800	14.00	12.20	25,900	21,500	26,800	8.00	14,000	1492552
	ASPF303616A*		28,400	22,200	14.00	12.20	26,300	21,800	26,800	8.00	14,000	1292148
	ASPF303616B*		28,400	22,200	14.00	12.20	26,300	21,800	26,800	8.00	14,000	1443981
	AT*F303016A*		28,000	21,800	13.00	11.50	25,900	21,500	26,000	8.00	15,000	1483529
	AWB36-XX		27,400	21,400	13.00	11.50	25,300	21,000	25,600	8.00	14,400	735171
	AWUF30XX16A*		27,400	21,400	13.00	11.50	25,300	21,000	25,600	8.00	14,400	3001441
	AWUF30XX1A*		27,400	21,400	13.00	11.50	25,300	21,000	25,600	8.00	14,400	1330440
	AWUF36XX16A*		27,400	21,400	13.00	11.50	25,300	21,000	25,600	8.00	14,400	3001442
AWUF36XX1A*		27,400	21,400	13.00	11.50	25,300	21,000	25,600	8.00	14,400	735086	
AWUF37XX16A*		27,400	21,400	13.00	11.50	25,300	21,000	26,000	8.00	15,000	3001443	
AWUF37XX1A*		27,400	21,400	13.00	11.50	25,300	21,000	26,000	8.00	15,000	1505960	
GSH13 0361A*	ADPF304216A*		35,000	26,600	13.00	11.50	32,400	26,200	32,000	7.70	16,000	1038063
	ADPF304216B*		35,000	26,600	13.00	11.50	32,400	26,200	32,000	7.70	16,000	1492553
	ADPF30421A*		35,000	26,600	13.00	11.50	32,400	26,200	32,000	7.70	16,000	735230
	ADPF30421B*		35,000	26,600	13.00	11.50	32,400	26,200	32,000	7.70	16,000	1069206
	AEPF303616A*		35,000	26,600	14.00	12.20	32,400	26,200	32,000	8.00	16,000	1038064
	AEPF303616B*		35,000	26,600	14.00	12.20	32,400	26,200	32,000	8.00	16,000	1277844
	AEPF303616C*		35,000	26,600	14.00	12.20	32,400	26,200	32,000	8.00	16,000	1443955
	AEPF30361A*		35,000	26,600	14.00	12.20	32,400	26,200	32,000	8.00	16,000	735159
	AEPF30361B*		35,000	26,600	14.00	12.20	32,400	26,200	32,000	8.00	16,000	1069207
	AEPF426016A*		35,000	26,600	14.00	12.20	32,400	26,200	32,000	8.00	16,000	1492652
	AEPF426016B*		35,000	26,600	14.00	12.20	32,400	26,200	32,000	8.00	16,000	1470768
	AEPF426016C*		35,000	26,600	14.00	12.20	32,400	26,200	32,000	8.00	16,000	1492554
	AEPT036-00*-1*		35,000	26,600	14.00	12.20	32,400	26,200	32,000	8.00	16,000	735158
	AR*F363616A*		34,400	26,100	13.00	11.50	31,800	25,800	32,600	7.80	16,000	1273411
	AR*F363616B*		34,400	26,100	13.00	11.50	31,800	25,800	32,600	7.80	16,000	1492555
	AR*F364216B*		35,000	26,600	13.00	11.50	32,400	26,200	32,000	8.00	16,000	1443973
	ARPF048-00B-1*		35,000	26,600	13.00	11.50	32,400	26,200	32,000	7.70	16,000	735115
	ARPF364216A*		35,000	26,600	13.00	11.50	32,400	26,200	32,000	7.70	16,000	1038065
	ARPF36421A*		35,000	26,600	13.00	11.50	32,400	26,200	32,000	7.70	16,000	735132
	ARPF36421B*		35,000	26,600	13.00	11.50	32,400	26,200	32,000	7.70	16,000	1069208
	ARPT049-00*-1*		35,000	26,600	13.00	11.50	32,400	26,200	32,000	7.70	16,000	735180
	ARUF048-00*-1*		34,000	25,800	13.00	11.50	31,500	25,500	32,000	7.80	16,000	1069244
	ARUF049-00*-1*		35,000	26,600	13.00	11.50	32,400	26,200	32,000	8.00	16,000	735837
	ARUF364216A*		35,000	26,600	13.00	11.50	32,400	26,200	32,000	7.70	16,000	1038066
	ARUF36421A*		35,000	26,600	13.00	11.50	32,400	26,200	32,000	8.00	16,000	735187
	ARUF36421B*		35,000	26,600	13.00	11.50	32,400	26,200	32,000	8.00	16,000	1069209
	ASPF303616A*		35,000	26,600	14.00	12.20	32,400	26,200	32,000	8.00	16,000	1291680

See Notes on Page 50.

ARI PERFORMANCE RATINGS (CONT.)

Outdoor Unit	Indoor Units		Cooling (BTU/h)				TVA Ratings		Heating (BTU/h)			ARI #
	Indoor Coil	Furnace/ Blower	Total	Sens.	SEER ¹	EER ²	Total	Sens.	High	HSPF ³	Low	
GSH13 0361A* (cont.)	ASPF303616B*		35,000	26,600	14.00	12.20	32,400	26,200	32,000	8.00	16,000	1443982
	ASPF426016A*		35,000	26,600	14.00	12.20	32,400	26,200	32,000	8.00	16,000	1292149
	ASPF426016B*		35,000	26,600	14.00	12.20	32,400	26,200	32,000	8.00	16,000	1492556
	AT*F363616A*		34,400	26,100	13.00	11.50	31,800	25,800	32,600	7.80	16,000	1483530
	AT*F364216A*		35,000	26,600	13.00	11.50	32,400	26,200	32,000	7.70	16,000	1483531
	AWUF37XX16A*		33,400	25,400	13.00	11.50	30,900	25,000	31,000	7.80	17,000	3001444
	AWUF37XX1A*		33,400	25,400	13.00	11.50	30,900	25,000	31,000	7.80	17,000	1505958
	CA*F060*2*	G*V80905C**	35,000	26,600	14.00	12.20	32,400	26,200	32,000	8.00	16,000	735100
	CA*F060*2*	G*V81155C**	35,000	26,600	14.00	12.20	32,400	26,200	32,000	8.00	16,000	735825
	CA*F060*2*	G*V90905D**	35,000	26,600	14.00	12.20	32,400	26,200	32,000	8.00	16,000	735067
	CA*F060*2*	G*V950905D**	35,000	26,600	13.50	11.80	32,400	26,200	32,000	7.70	16,000	735978
	CA*F060*2*	G*V951155D**	35,000	26,600	13.50	11.80	32,400	26,200	32,000	7.70	16,000	735987
	CA*F060*2*+EEP		35,000	26,600	13.00	11.50	32,400	26,200	32,000	7.70	16,000	735822
	CA*F060*2*	MBE1600**-1	35,000	26,600	14.00	12.20	32,400	26,200	32,000	8.00	16,000	1032336
	CA*F3636*6A*	G*V90704C**	33,600	25,500	13.50	11.80	31,100	25,200	32,000	8.00	16,000	1456151
	CA*F3636*6A*	G*V950704C**	33,600	25,500	13.50	11.80	31,100	25,200	32,000	8.00	16,000	1350896
	CA*F3636*6A*+TXV	G*V950704C**	33,600	25,500	13.70	12.00	31,100	25,200	32,000	8.00	16,000	1352844
	CA*F3636*6B*	G*V90704C**	33,600	25,500	13.50	11.80	31,100	25,200	32,000	8.00	16,000	1456157
	CA*F3642*6A*	G*E80905C**	35,000	26,600	14.00	12.20	32,400	26,200	32,000	8.00	16,000	1273341
	CA*F3642*6A*	G*V80905C**	35,000	26,600	14.00	12.20	32,400	26,200	32,000	8.00	16,000	735976
	CA*F3642*6A*	G*V81155C**	35,000	26,600	14.00	12.20	32,400	26,200	32,000	8.00	16,000	735827
	CA*F3642*6A*	G*V90905D**	35,000	26,600	14.00	12.20	32,400	26,200	32,000	8.00	16,000	735996
	CA*F3642*6A*	G*V950704C**	34,000	25,800	13.50	11.80	31,500	25,500	32,000	8.00	16,000	1352842
	CA*F3642*6A*	G*V950905D**	35,000	26,600	13.50	11.80	32,400	26,200	32,000	7.70	16,000	735977
	CA*F3642*6A*	G*V951155D**	35,000	26,600	13.50	11.80	32,400	26,200	32,000	7.70	16,000	735995
	CA*F3642*6A*+EEP		35,000	26,600	13.00	11.50	32,400	26,200	32,000	7.70	16,000	735839
	CA*F3642*6A*	MBE1600**-1	35,000	26,600	14.00	12.20	32,400	26,200	32,000	8.00	16,000	1032337
	CA*F3642*6A*+TXV	G*V90704C**	34,400	26,100	13.50	11.80	31,800	25,800	32,000	8.00	16,000	1352847
	CA*F3642*6A*+TXV	G*V950704C**	34,000	25,800	13.70	12.00	31,500	25,500	32,000	8.00	16,000	1352845
	CA*F3642*6B*	G*E80905C**	35,000	26,600	14.00	12.20	32,400	26,200	32,000	8.00	16,000	1348597
	CA*F3642*6B*	G*V80905C**	35,000	26,600	14.00	12.20	32,400	26,200	32,000	8.00	16,000	1347200
	CA*F3642*6B*	G*V81155C**	35,000	26,600	14.00	12.20	32,400	26,200	32,000	8.00	16,000	1347201
	CA*F3642*6B*	G*V90905D**	35,000	26,600	14.00	12.20	32,400	26,200	32,000	8.00	16,000	1347202
	CA*F3642*6B*	G*V950905D**	35,000	26,600	13.50	11.80	32,400	26,200	32,000	7.70	16,000	1347203
	CA*F3642*6B*	G*V951155D**	35,000	26,600	13.50	11.80	32,400	26,200	32,000	7.70	16,000	1347204
	CA*F3642*6B*	G*V951155D**	35,000	26,600	13.50	11.80	32,400	26,200	32,000	7.70	16,000	1347199
	CA*F3642*6B*+EEP		35,000	26,600	13.00	11.50	32,400	26,200	32,000	7.70	16,000	1347205
	CA*F3642*6B*	MBE1600**-1	35,000	26,600	14.00	12.20	32,400	26,200	32,000	8.00	16,000	1346680
	CHPF048D2*	G*V90905D**	35,000	26,600	14.00	12.20	32,400	26,200	32,000	8.00	16,000	735848
	CHPF048D2*	G*V950905D**	35,000	26,600	13.50	11.80	32,400	26,200	32,000	7.70	16,000	735993
	CHPF048D2*	G*V951155D**	35,000	26,600	13.50	11.80	32,400	26,200	32,000	7.70	16,000	735983
	CHPF048D2*+EEP		35,000	26,600	13.00	11.50	32,400	26,200	32,000	7.70	16,000	735845
	CHPF3636B6A*+EEP		35,000	26,600	13.00	11.50	32,400	26,200	32,000	7.70	16,000	735806
	CHPF3636B6B*+EEP		35,000	26,600	13.00	11.50	32,400	26,200	32,000	7.70	16,000	1330392
	CHPF3642C6A*	G*E80905C**	35,000	26,600	14.00	12.20	32,400	26,200	32,000	7.80	16,000	1273342
	CHPF3642C6A*	G*V80905C**	35,000	26,600	14.00	12.20	32,400	26,200	32,000	7.70	16,000	735831
	CHPF3642C6A*	G*V81155C**	35,000	26,600	14.00	12.20	32,400	26,200	32,000	8.00	16,000	735805
	CHPF3642C6A*+EEP		35,000	26,600	13.00	11.50	32,400	26,200	32,000	7.70	16,000	735803
	CHPF3642C6B*	G*E80905C**	35,000	26,600	14.00	12.20	32,400	26,200	32,000	7.80	16,000	1347594
	CHPF3642C6B*	G*V80905C**	35,000	26,600	14.00	12.20	32,400	26,200	32,000	7.70	16,000	1348598

See Notes on Page 50.

ARI PERFORMANCE RATINGS (CONT.)

Outdoor Unit	Indoor Units		Cooling (BTU/h)				TVA Ratings		Heating (BTU/h)			ARI #
	Indoor Coil	Furnace/ Blower	Total	Sens.	SEER ¹	EER ²	Total	Sens.	High	HSPF ³	Low	
GSH13 0361A* (cont.)	CHPF3642C6B*	G*V81155C**	35,000	26,600	14.00	12.20	32,400	26,200	32,000	8.00	16,000	1330393
	CHPF3642C6B*	G*V81155C**	35,000	26,600	14.00	12.20	32,400	26,200	32,000	8.00	16,000	1330394
	CHPF3642C6B*+EEP		35,000	26,600	13.00	11.50	32,400	26,200	32,000	7.70	16,000	1330395
	CHPF3642D6A*	G*V90905D**	35,000	26,600	14.00	12.20	32,400	26,200	32,000	8.00	16,000	735828
	CHPF3642D6A*	G*V950905D**	35,000	26,600	13.50	11.80	32,400	26,200	32,000	7.70	16,000	735997
	CHPF3642D6A*	G*V951155D**	35,000	26,600	13.50	11.80	32,400	26,200	32,000	7.70	16,000	735985
	CHPF3642D6A*+EEP		35,000	26,600	13.00	11.50	32,400	26,200	32,000	7.70	16,000	735810
	CHPF3642D6B*	G*V90905D**	35,000	26,600	14.00	12.20	32,400	26,200	32,000	8.00	16,000	1348599
	CHPF3642D6B*	G*V950905D**	35,000	26,600	13.50	11.80	32,400	26,200	32,000	7.70	16,000	1330397
	CHPF3642D6B*	G*V951155D**	35,000	26,600	13.50	11.80	32,400	26,200	32,000	7.70	16,000	1330398
	CHPF3642D6B*	G*V951155D**	35,000	26,600	13.50	11.80	32,400	26,200	32,000	7.70	16,000	1330396
	CHPF3642D6B*+EEP		35,000	26,600	13.00	11.50	32,400	26,200	32,000	7.70	16,000	1330399
	CSCF3642N6A*	G*E80905C**	35,000	26,600	14.00	12.20	32,400	26,200	32,000	8.00	16,000	1273343
	CSCF3642N6A*	G*V80905C**	35,000	26,600	14.00	12.20	32,400	26,200	32,000	8.00	16,000	735988
	CSCF3642N6A*	G*V81155C**	35,000	26,600	14.00	12.20	32,400	26,200	32,000	8.00	16,000	735982
	CSCF3642N6A*	G*V90905D**	35,000	26,600	14.00	12.20	32,400	26,200	32,000	8.00	16,000	735830
	CSCF3642N6A*	G*V950905D**	35,000	26,600	13.50	11.80	32,400	26,200	32,000	7.70	16,000	735990
	CSCF3642N6A*	G*V951155D**	35,000	26,600	13.50	11.80	32,400	26,200	32,000	7.70	16,000	735975
	CSCF3642N6A*+EEP		35,000	26,600	13.00	11.50	32,400	26,200	32,000	7.70	16,000	735814
	CSCF3642N6C*	G*E80905C**	35,000	26,600	14.00	12.20	32,400	26,200	32,000	8.00	16,000	1348600
	CSCF3642N6C*	G*V80905C**	35,000	26,600	14.00	12.20	32,400	26,200	32,000	8.00	16,000	1296597
	CSCF3642N6C*	G*V81155C**	35,000	26,600	14.00	12.20	32,400	26,200	32,000	8.00	16,000	1296598
	CSCF3642N6C*	G*V90905D**	35,000	26,600	14.00	12.20	32,400	26,200	32,000	8.00	16,000	1296599
	CSCF3642N6C*	G*V950905D**	35,000	26,600	13.50	11.80	32,400	26,200	32,000	7.70	16,000	1296600
	CSCF3642N6C*	G*V951155D**	35,000	26,600	13.50	11.80	32,400	26,200	32,000	7.70	16,000	1296586
	CSCF3642N6C*	G*V951155D**	35,000	26,600	13.50	11.80	32,400	26,200	32,000	7.70	16,000	1296601
	CSCF3642N6C*+EEP		35,000	26,600	13.00	11.50	32,400	26,200	32,000	7.70	16,000	1296602
	CT*F3636*6A*	G*V950704C**	33,600	25,500	13.50	11.80	31,100	25,200	32,000	8.00	16,000	1449937
	CT*F3636*6A*+TXV	G*V950704C**	33,600	25,500	13.70	12.00	31,100	25,200	32,000	8.00	16,000	1449938
	CT*F3642*6A*	G*E80905C**	35,000	26,600	14.00	12.20	32,400	26,200	32,000	8.00	16,000	1449939
	CT*F3642*6A*	G*V80905C**	35,000	26,600	14.00	12.20	32,400	26,200	32,000	8.00	16,000	1449940
	CT*F3642*6A*	G*V81155C**	35,000	26,600	14.00	12.20	32,400	26,200	32,000	8.00	16,000	1449941
	CT*F3642*6A*	G*V90905D**	35,000	26,600	14.00	12.20	32,400	26,200	32,000	8.00	16,000	1449942
	CT*F3642*6A*	G*V950704C**	34,000	25,800	13.50	11.80	31,500	25,500	32,000	8.00	16,000	1449943
	CT*F3642*6A*	G*V950905D**	35,000	26,600	13.50	11.80	32,400	26,200	32,000	7.70	16,000	1449944
	CT*F3642*6A*	G*V951155D**	35,000	26,600	13.50	11.80	32,400	26,200	32,000	7.70	16,000	1449945
	CT*F3642*6A*+EEP		35,000	26,600	13.00	11.50	32,400	26,200	32,000	7.70	16,000	1449946
	CT*F3642*6A*	MBE1600**-1	35,000	26,600	14.00	12.20	32,400	26,200	32,000	8.00	16,000	1449947
	CT*F3642*6A*+TXV	G*V90704C**	34,400	26,100	13.50	11.80	31,800	25,800	32,000	8.00	16,000	1449948
	CT*F3642*6A*+TXV	G*V950704C**	34,000	25,800	13.70	12.00	31,500	25,500	32,000	8.00	16,000	1449949
	H60F	G*V80905C**	35,000	26,600	14.00	12.20	32,400	26,200	32,000	8.00	16,000	735120
	H60F	G*V81155C**	35,000	26,600	14.00	12.20	32,400	26,200	32,000	8.00	16,000	735842
H60F	G*V90905D**	35,000	26,600	14.00	12.20	32,400	26,200	32,000	8.00	16,000	735068	
H60F	G*V950905D**	35,000	26,600	13.50	11.80	32,400	26,200	32,000	7.70	16,000	735992	
H60F	G*V951155D**	35,000	26,600	13.50	11.80	32,400	26,200	32,000	7.70	16,000	735974	
H60F+EEP		35,000	26,600	13.00	11.50	32,400	26,200	32,000	7.70	16,000	735811	
ARUF049-00*-1*		35,000	26,600	13.00	11.50	32,400	26,200	32,000	7.70	16,000	735864	
ARUF364216A*		35,000	26,600	13.00	11.50	32,400	26,200	32,000	7.70	16,000	1038086	
ARUF36421A*		35,000	26,600	13.00	11.50	32,400	26,200	32,000	7.70	16,000	735898	
ARUF36421B*		35,000	26,600	13.00	11.50	32,400	26,200	32,000	7.70	16,000	1069189	

See Notes on Page 50.

ARI PERFORMANCE RATINGS (CONT.)

Outdoor Unit	Indoor Units		Cooling (BTU/h)				TVA Ratings		Heating (BTU/h)			ARI #
	Indoor Coil	Furnace/ Blower	Total	Sens.	SEER ¹	EER ²	Total	Sens.	High	HSPF ³	Low	
GSH13 0361A* (cont.)	ASPF303616A*		35,000	26,600	14.00	12.20	32,400	26,200	32,000	8.00	16,000	1291684
	ASPF303616B*		35,000	26,600	14.00	12.20	32,400	26,200	32,000	8.00	16,000	1443983
	AT*F364216A*		35,000	26,600	13.00	11.50	32,400	26,200	32,000	7.70	16,000	1483532
	CA*F060*2*+EEP		35,000	26,600	13.00	11.50	32,400	26,200	32,000	7.70	16,000	735887
	CA*F3642*6A*+EEP		35,000	26,600	13.00	11.50	32,400	26,200	32,000	7.70	16,000	735861
	CA*F3642*6B*+EEP		35,000	26,600	13.00	11.50	32,400	26,200	32,000	7.70	16,000	1347206
	CHPF048D2*+EEP		35,000	26,600	13.00	11.50	32,400	26,200	32,000	7.70	16,000	735852
	CHPF3636B6A*+EEP		35,000	26,600	13.00	11.50	32,400	26,200	32,000	7.70	16,000	735854
	CHPF3636B6B*+EEP		35,000	26,600	13.00	11.50	32,400	26,200	32,000	7.70	16,000	1330400
	CHPF3642C6A*+EEP		35,000	26,600	13.00	11.50	32,400	26,200	32,000	7.70	16,000	735914
	CHPF3642C6B*+EEP		35,000	26,600	13.00	11.50	32,400	26,200	32,000	7.70	16,000	1330401
	CHPF3642D6A*+EEP		35,000	26,600	13.00	11.50	32,400	26,200	32,000	7.70	16,000	735884
	CHPF3642D6B*+EEP		35,000	26,600	13.00	11.50	32,400	26,200	32,000	7.70	16,000	1330402
	CSCF3642N6A*+EEP		35,000	26,600	13.00	11.50	32,400	26,200	32,000	7.70	16,000	735856
	CSCF3642N6C*+EEP		35,000	26,600	13.00	11.50	32,400	26,200	32,000	7.70	16,000	1296603
	CT*F3642*6A*+EEP		35,000	26,600	13.00	11.50	32,400	26,200	32,000	7.70	16,000	1449950
H60F+EEP		35,000	26,600	13.00	11.50	32,400	26,200	32,000	7.70	16,000	735905	
GSH13 0361B*	ADPF304216A*		35,000	26,600	13.0	11.5	32,400	26,200	32,000	7.7	16,000	3054458
	ADPF304216B*		35,000	26,600	13.0	11.5	32,400	26,200	32,000	7.7	16,000	3054459
	AEPF303616B*		35,000	26,600	14.0	12.2	32,400	26,200	32,000	8.0	16,000	3054460
	AEPF303616C*		35,000	26,600	14.0	12.2	32,400	26,200	32,000	8.0	16,000	3054461
	AEPF426016B*		35,000	26,600	14.0	12.2	32,400	26,200	32,000	8.0	16,000	3054462
	AEPF426016C*		35,000	26,600	14.0	12.2	32,400	26,200	32,000	8.0	16,000	3054463
	AR*F363616A*		34,400	26,100	13.0	11.5	31,800	25,800	32,600	7.8	16,000	3054464
	AR*F363616B*		34,400	26,100	13.0	11.5	31,800	25,800	32,600	7.8	16,000	3054465
	AR*F364216B*		35,000	26,600	13.0	11.2	32,400	26,200	32,000	7.7	19,400	3054466
	ARPF364216A*		35,000	26,600	13.0	11.5	32,400	26,200	32,000	7.7	16,000	3054467
	ASPF303616A*		35,000	26,600	14.0	12.2	32,400	26,200	32,000	8.0	16,000	3054468
	ASPF303616B*		35,000	26,600	14.0	12.2	32,400	26,200	32,000	8.0	16,000	3054469
	ASPF426016A*		35,000	26,600	14.0	12.2	32,400	26,200	32,000	8.0	16,000	3054470
	ASPF426016B*		35,000	26,600	14.0	12.2	32,400	26,200	32,000	8.0	16,000	3012098
	AT*F363616A*		34,400	26,100	13.0	11.5	31,800	25,800	32,600	7.8	16,000	3012099
	AT*F364216A*		35,000	26,600	13.0	11.5	32,400	26,200	32,000	7.7	16,000	3012100
	AWUF37XX16A*		33,400	25,400	13.0	11.5	30,900	25,000	31,000	7.8	17,000	3012102
	AWUF37XX1A*		33,400	25,400	13.0	11.5	30,900	25,000	31,000	7.8	17,000	3012101
	CA*F3636*6A*	G*V950704C**	33,600	25,500	13.5	11.8	31,100	25,200	32,000	8.0	16,000	3012104
	CA*F3636*6A*	G*V90704C**	33,600	25,500	13.5	11.8	31,100	25,200	32,000	8.0	16,000	3012103
	CA*F3636*6A*+TXV	G*V950704C**	33,600	25,500	13.7	12.0	31,100	25,200	32,000	8.0	16,000	3012105
	CA*F3636*6B*	G*V90704C**	33,600	25,500	13.5	11.8	31,100	25,200	32,000	8.0	16,000	3012106
	CA*F3642*6A*	G*E80905C**	35,000	26,600	14.0	12.2	32,400	26,200	32,000	8.0	16,000	3012107
	CA*F3642*6A*	G*V81155C**	35,000	26,600	14.0	12.2	32,400	26,200	32,000	8.0	16,000	3012109
	CA*F3642*6A*	G*V950905D**	35,000	26,600	13.5	11.8	32,400	26,200	32,000	7.7	16,000	3012112
	CA*F3642*6A*	G*V950704C**	34,000	25,800	13.5	11.8	31,500	25,500	32,000	8.0	16,000	3012111
	CA*F3642*6A*	G*V80905C**	35,000	26,600	14.0	12.2	32,400	26,200	32,000	8.0	16,000	3012108
	CA*F3642*6A*	G*V90905D**	35,000	26,600	14.0	12.2	32,400	26,200	32,000	8.0	16,000	3012110
	CA*F3642*6A*	G*V951155D**	35,000	26,600	13.5	11.8	32,400	26,200	32,000	7.7	16,000	3012113
	CA*F3642*6A*+EEP		35,000	26,600	13.0	11.5	32,400	26,200	32,000	7.7	16,000	3012114
	CA*F3642*6A*	MBE1600**-1	35,000	26,600	14.0	12.2	32,400	26,200	32,000	8.0	16,000	3012115
	CA*F3642*6A*+TXV	G*V90704C**	34,400	26,100	13.5	11.8	31,800	25,800	32,000	8.0	16,000	3012116
CA*F3642*6A*+TXV	G*V950704C**	34,000	25,800	13.7	12.0	31,500	25,500	32,000	8.0	16,000	3012117	

See Notes on Page 50.

ARI PERFORMANCE RATINGS (CONT.)

Outdoor Unit	Indoor Units		Cooling (BTU/h)				TVA Ratings		Heating (BTU/h)			ARI #
	Indoor Coil	Furnace/ Blower	Total	Sens.	SEER ¹	EER ²	Total	Sens.	High	HSPF ³	Low	
GSH13 0361B* (cont.)	CA*F3642*6B*	G*V80905C**	35,000	26,600	14.0	12.2	32,400	26,200	32,000	8.0	16,000	3012119
	CA*F3642*6B*	G*V950905D**	35,000	26,600	13.5	11.8	32,400	26,200	32,000	7.7	16,000	3012122
	CA*F3642*6B*	G*E80905C**	35,000	26,600	14.0	12.2	32,400	26,200	32,000	8.0	16,000	3012118
	CA*F3642*6B*	G*V81155C**	35,000	26,600	14.0	12.2	32,400	26,200	32,000	8.0	16,000	3012120
	CA*F3642*6B*	G*V90905D**	35,000	26,600	14.0	12.2	32,400	26,200	32,000	8.0	16,000	3012121
	CA*F3642*6B*	G*V951155D**	35,000	26,600	13.5	11.8	32,400	26,200	32,000	7.7	16,000	3012123
	CA*F3642*6B*+EEP		35,000	26,600	13.0	11.5	32,400	26,200	32,000	7.7	16,000	3012124
	CA*F3642*6B*	MBE1600**-1	35,000	26,600	14.0	12.2	32,400	26,200	32,000	8.0	16,000	3012125
	CA*F3743*6A*	G*V950905D**	35,000	26,600	13.5	11.8	32,400	26,200	32,000	7.7	16,000	3054476
	CA*F3743*6A*	G*V950704C**	34,000	25,800	13.5	11.8	31,500	25,500	32,000	8.0	16,000	3054475
	CA*F3743*6A*	G*V80905C**	35,000	26,600	14.0	12.2	32,400	26,200	32,000	8.0	16,000	3054472
	CA*F3743*6A*	G*V951155D**	35,000	26,600	13.5	11.8	32,400	26,200	32,000	7.7	16,000	3054477
	CA*F3743*6A*	G*V90905D**	35,000	26,600	14.0	12.2	32,400	26,200	32,000	8.0	16,000	3054474
	CA*F3743*6A*	G*E80905C**	35,000	26,600	14.0	12.2	32,400	26,200	32,000	8.0	16,000	3054471
	CA*F3743*6A*	G*V81155C**	35,000	26,600	14.0	12.2	32,400	26,200	32,000	8.0	16,000	3054473
	CA*F3743*6A*+EEP		35,000	26,600	13.0	11.5	32,400	26,200	32,000	7.7	16,000	3054478
	CA*F3743*6A*	MBE1600**-1	35,000	26,600	14.0	12.2	32,400	26,200	32,000	8.0	16,000	3054479
	CA*F3743*6A*+TXV	G*V90704C**	34,400	26,100	13.5	11.8	31,800	25,800	32,000	8.0	16,000	3054480
	CA*F3743*6A*+TXV	G*V950704C**	34,000	25,800	13.7	12.0	31,500	25,500	32,000	8.0	16,000	3054481
	CHPF3636B6A*+EEP		35,000	26,600	13.0	11.5	32,400	26,200	32,000	7.7	16,000	3012126
	CHPF3636B6B*+EEP		35,000	26,600	13.0	11.5	32,400	26,200	32,000	7.7	16,000	3012127
	CHPF3642C6A*	G*E80905C**	35,000	26,600	14.0	12.2	32,400	26,200	32,000	7.8	16,000	3012128
	CHPF3642C6A*	G*V81155C**	35,000	26,600	14.0	12.2	32,400	26,200	32,000	8.0	16,000	3012130
	CHPF3642C6A*	G*V80905C**	35,000	26,600	14.0	12.2	32,400	26,200	32,000	7.7	16,000	3012129
	CHPF3642C6A*+EEP		35,000	26,600	13.0	11.5	32,400	26,200	32,000	7.7	16,000	3012131
	CHPF3642C6B*	G*E80905C**	35,000	26,600	14.0	12.2	32,400	26,200	32,000	7.8	16,000	3012132
	CHPF3642C6B*	G*V80905C**	35,000	26,600	14.0	12.2	32,400	26,200	32,000	7.7	16,000	3012133
	CHPF3642C6B*	G*V81155C**	35,000	26,600	14.0	12.2	32,400	26,200	32,000	8.0	16,000	3012134
	CHPF3642C6B*+EEP		35,000	26,600	13.0	11.5	32,400	26,200	32,000	7.7	16,000	3012135
	CHPF3642D6A*	G*V950905D**	35,000	26,600	13.5	11.8	32,400	26,200	32,000	7.7	16,000	3012137
	CHPF3642D6A*	G*V951155D**	35,000	26,600	13.5	11.8	32,400	26,200	32,000	7.7	16,000	3012138
	CHPF3642D6A*	G*V90905D**	35,000	26,600	14.0	12.2	32,400	26,200	32,000	8.0	16,000	3012136
	CHPF3642D6A*+EEP		35,000	26,600	13.0	11.5	32,400	26,200	32,000	7.7	16,000	3012139
	CHPF3642D6B*	G*V950905D**	35,000	26,600	13.5	11.8	32,400	26,200	32,000	7.7	16,000	3012141
	CHPF3642D6B*	G*V951155D**	35,000	26,600	13.5	11.8	32,400	26,200	32,000	7.7	16,000	3012142
	CHPF3642D6B*	G*V90905D**	35,000	26,600	14.0	12.2	32,400	26,200	32,000	8.0	16,000	3012140
	CHPF3642D6B*+EEP		35,000	26,600	13.0	11.5	32,400	26,200	32,000	7.7	16,000	3012143
	CSCF3642N6A*	G*E80905C**	35,000	26,600	14.0	12.2	32,400	26,200	32,000	8.0	16,000	3012144
	CSCF3642N6A*	G*V81155C**	35,000	26,600	14.0	12.2	32,400	26,200	32,000	8.0	16,000	3012146
	CSCF3642N6A*	G*V950905D**	35,000	26,600	13.5	11.8	32,400	26,200	32,000	7.7	16,000	3012148
	CSCF3642N6A*	G*V90905D**	35,000	26,600	14.0	12.2	32,400	26,200	32,000	8.0	16,000	3012147
	CSCF3642N6A*	G*V951155D**	35,000	26,600	13.5	11.8	32,400	26,200	32,000	7.7	16,000	3012149
	CSCF3642N6A*	G*V80905C**	35,000	26,600	14.0	12.2	32,400	26,200	32,000	8.0	16,000	3012145
	CSCF3642N6A*+EEP		35,000	26,600	13.0	11.5	32,400	26,200	32,000	7.7	16,000	3012150
	CSCF3642N6C*	G*V80905C**	35,000	26,600	14.0	12.2	32,400	26,200	32,000	8.0	16,000	3012152
	CSCF3642N6C*	G*V951155D**	35,000	26,600	13.5	11.8	32,400	26,200	32,000	7.7	16,000	3012156
	CSCF3642N6C*	G*E80905C**	35,000	26,600	14.0	12.2	32,400	26,200	32,000	8.0	16,000	3012151
	CSCF3642N6C*	G*V81155C**	35,000	26,600	14.0	12.2	32,400	26,200	32,000	8.0	16,000	3012153
	CSCF3642N6C*	G*V950905D**	35,000	26,600	13.5	11.8	32,400	26,200	32,000	7.7	16,000	3012155
	CSCF3642N6C*	G*V90905D**	35,000	26,600	14.0	12.2	32,400	26,200	32,000	8.0	16,000	3012154
CSCF3642N6C*+EEP		35,000	26,600	13.0	11.5	32,400	26,200	32,000	7.7	16,000	3012157	
CT*F3636*6A*	G*V950704C**	33,600	25,500	13.5	11.8	31,100	25,200	32,000	8.0	16,000	3012158	

See Notes on Page 58.

ARI PERFORMANCE RATINGS (CONT.)

Outdoor Unit	Indoor Units		Cooling (BTU/h)				TVA Ratings		Heating (BTU/h)			ARI #
	Indoor Coil	Furnace/ Blower	Total	Sens.	SEER ¹	EER ²	Total	Sens.	High	HSPF ³	Low	
GSH13 0361B* (cont.)	CT*F3636*6A*+TXV	G*V950704C**	33,600	25,500	13.7	12.0	31,100	25,200	32,000	8.0	16,000	3012159
	CT*F3642*6A*	G*V950704C**	34,000	25,800	13.5	11.8	31,500	25,500	32,000	8.0	16,000	3012164
	CT*F3642*6A*	G*E80905C**	35,000	26,600	14.0	12.2	32,400	26,200	32,000	8.0	16,000	3012160
	CT*F3642*6A*	G*V81155C**	35,000	26,600	14.0	12.2	32,400	26,200	32,000	8.0	16,000	3012162
	CT*F3642*6A*	G*V90905D**	35,000	26,600	14.0	12.2	32,400	26,200	32,000	8.0	16,000	3012163
	CT*F3642*6A*	G*V950905D**	35,000	26,600	13.5	11.8	32,400	26,200	32,000	7.7	16,000	3012165
	CT*F3642*6A*	G*V951155D**	35,000	26,600	13.5	11.8	32,400	26,200	32,000	7.7	16,000	3012166
	CT*F3642*6A*	G*V80905C**	35,000	26,600	14.0	12.2	32,400	26,200	32,000	8.0	16,000	3012161
	CT*F3642*6A*+EEP		35,000	26,600	13.0	11.5	32,400	26,200	32,000	7.7	16,000	3012167
	CT*F3642*6A*	MBE1600**-1	35,000	26,600	14.0	12.2	32,400	26,200	32,000	8.0	16,000	3012168
	CT*F3642*6A*+TXV	G*V90704C**	34,400	26,100	13.5	11.8	31,800	25,800	32,000	8.0	16,000	3012169
	CT*F3642*6A*+TXV	G*V950704C**	34,000	25,800	13.7	12.0	31,500	25,500	32,000	8.0	16,000	3012170
GSH13 0363A*	ADPF304216A*		35,000	26,600	13.00	11.50	32,400	26,200	32,000	7.70	16,000	1038099
	ADPF304216B*		35,000	26,600	13.00	11.50	32,400	26,200	32,000	7.70	16,000	1492557
	ADPF30421A*		35,000	26,600	13.00	11.50	32,400	26,200	32,000	7.70	16,000	735888
	ADPF30421B*		35,000	26,600	13.00	11.50	32,400	26,200	32,000	7.70	16,000	1069202
	AEPF303616A*		35,000	26,600	14.00	12.20	32,400	26,200	32,000	8.00	16,000	1038088
	AEPF303616B*		35,000	26,600	14.00	12.20	32,400	26,200	32,000	8.00	16,000	1277845
	AEPF303616C*		35,000	26,600	14.00	12.20	32,400	26,200	32,000	8.00	16,000	1443956
	AEPF30361A*		35,000	26,600	14.00	12.20	32,400	26,200	32,000	8.00	16,000	735902
	AEPF30361B*		35,000	26,600	14.00	12.20	32,400	26,200	32,000	8.00	16,000	1069203
	AEPF426016A*		35,000	26,600	14.00	12.20	32,400	26,200	32,000	8.00	16,000	1492653
	AEPF426016B*		35,000	26,600	14.00	12.20	32,400	26,200	32,000	8.00	16,000	1444038
	AEPF426016C*		35,000	26,600	14.00	12.20	32,400	26,200	32,000	8.00	16,000	1492558
	AEPT036-00*-1*		35,000	26,600	14.00	12.20	32,400	26,200	32,000	8.00	16,000	735883
	AR*F364216B*		35,000	26,600	13.00	11.50	32,400	26,200	32,000	7.70	16,000	1443974
	ARPF048-00B-1*		35,000	26,600	13.00	11.50	32,400	26,200	32,000	7.70	16,000	735900
	ARPF364216A*		35,000	26,600	13.00	11.50	32,400	26,200	32,000	7.70	16,000	1038087
	ARPF36421A*		35,000	26,600	13.00	11.50	32,400	26,200	32,000	7.70	16,000	735908
	ARPF36421B*		35,000	26,600	13.00	11.50	32,400	26,200	32,000	7.70	16,000	1069204
ARPT049-00*-1*		35,000	26,600	13.00	11.50	32,400	26,200	32,000	7.70	16,000	735868	
GSH13 0421A*	ADPF304216A*		40,000	30,400	13.00	11.50	37,000	30,000	39,000	8.00	23,000	1038067
	ADPF304216B*		40,000	30,400	13.00	11.50	37,000	30,000	39,000	8.00	23,000	1492559
	ADPF30421A*		40,000	30,400	13.00	11.50	37,000	30,000	39,000	8.00	23,000	735223
	ADPF30421B*		40,000	30,400	13.00	11.50	37,000	30,000	39,000	8.00	23,000	1069240
	AEPF426016A*		41,000	31,200	14.00	12.20	37,900	30,700	39,500	8.20	23,000	1038068
	AEPF426016B*		41,000	31,200	14.00	12.20	37,900	30,700	39,500	8.20	23,000	1277846
	AEPF426016C*		41,000	31,200	14.00	12.20	37,900	30,700	39,500	8.20	23,000	1492560
	AEPF42601A*		41,000	31,200	14.00	12.20	37,900	30,700	39,500	8.20	23,000	735088
	AEPF42601B*		41,000	31,200	14.00	12.20	37,900	30,700	39,500	8.20	23,000	1069241
	AEPT060-00*-1*		41,000	31,200	14.00	12.20	37,900	30,700	39,500	8.20	23,000	735234
	AR*F364216B*		40,000	30,400	13.00	11.50	37,000	30,000	39,000	8.00	23,000	1443975
	ARPF048-00B-1*		40,000	30,400	13.00	11.50	37,000	30,000	39,000	8.00	23,000	735206
	ARPF364216A*		40,000	30,400	13.00	11.50	37,000	30,000	39,000	8.00	23,000	1038069
	ARPF36421A*		40,000	30,400	13.00	11.50	37,000	30,000	39,000	8.00	23,000	735258
	ARPF36421B*		40,000	30,400	13.00	11.50	37,000	30,000	39,000	8.00	23,000	1069242
	ARPT049-00*-1*		40,000	30,400	13.00	11.50	37,000	30,000	39,000	8.00	23,000	735077
	ARUF049-00*-1*		40,000	30,400	13.00	11.50	37,000	30,000	39,000	8.00	23,000	735109
	ARUF364216A*		40,000	30,400	13.00	11.50	37,000	30,000	39,000	8.00	23,000	1038070
ARUF36421A*		40,000	30,400	13.00	11.50	37,000	30,000	39,000	8.00	23,000	735150	

See Notes on Page 58.

ARI PERFORMANCE RATINGS (CONT.)

Outdoor Unit	Indoor Units		Cooling (BTU/h)				TVA Ratings		Heating (BTU/h)			ARI #
	Indoor Coil	Furnace/ Blower	Total	Sens.	SEER ¹	EER ²	Total	Sens.	High	HSPF ³	Low	
GSH13 0421A* (cont.)	ARUF36421B*		40,000	30,400	13.00	11.50	37,000	30,000	39,000	8.00	23,000	1069238
	ASPF426016A*		41,000	31,200	14.00	12.20	37,900	30,700	39,500	8.20	23,000	1291681
	ASPF426016B*		41,000	31,200	14.00	12.20	37,900	30,700	39,500	8.20	23,000	1492561
	AT*F364216A*		40,000	30,400	13.00	11.50	37,000	30,000	39,000	8.00	23,000	1483533
	CA*F060*2*+EEP		40,000	30,400	13.00	11.50	37,000	30,000	39,000	8.00	23,000	735909
	CA*F060*2*	MBE1600**-1	41,000	31,200	14.00	12.20	37,900	30,700	39,000	8.20	23,000	1032339
	CA*F061*2*	G*V80905C**	41,000	31,200	14.00	12.20	37,900	30,700	39,000	8.20	23,000	735247
	CA*F061*2*	G*V81155C**	41,000	31,200	14.00	12.20	37,900	30,700	39,000	8.20	23,000	735807
	CA*F061*2*	G*V90905D**	41,000	31,200	13.50	11.80	37,900	30,700	39,000	8.00	23,000	735105
	CA*F061*2*	G*V950905D**	41,000	31,200	13.50	11.80	37,900	30,700	39,000	8.00	23,000	735197
	CA*F061*2*	G*V951155D**	41,000	31,200	13.50	11.80	37,900	30,700	39,000	8.00	23,000	735191
	CA*F3642*6A*+EEP		40,000	30,400	13.00	11.50	37,000	30,000	39,000	8.00	23,000	735863
	CA*F3642*6A*	MBE1600**-1	41,000	31,200	14.00	12.20	37,900	30,700	39,000	8.20	23,000	1032342
	CA*F3642*6B*+EEP		40,000	30,400	13.00	11.50	37,000	30,000	39,000	8.00	23,000	1347207
	CA*F3642*6B*	MBE1600**-1	41,000	31,200	14.00	12.20	37,900	30,700	39,000	8.20	23,000	1346681
	CA*F4860*6A*	G*E80905C**	41,000	31,200	14.00	12.20	37,900	30,700	39,000	8.20	23,000	1273344
	CA*F4860*6A*	G*E81155C**	41,000	31,200	14.00	12.20	37,900	30,700	39,000	8.20	23,000	1273358
	CA*F4860*6A*	G*V80905C**	41,000	31,200	14.00	12.20	37,900	30,700	39,000	8.20	23,000	735129
	CA*F4860*6A*	G*V81155C**	41,000	31,200	14.00	12.20	37,900	30,700	39,000	8.20	23,000	735218
	CA*F4860*6A*	G*V90905D**	41,000	31,200	13.50	11.80	37,900	30,700	39,000	8.00	23,000	735820
	CA*F4860*6A*	G*V950905D**	41,000	31,200	13.50	11.80	37,900	30,700	39,000	8.00	23,000	1031642
	CA*F4860*6A*	G*V951155D**	41,000	31,200	13.50	11.80	37,900	30,700	39,000	8.00	23,000	735250
	CA*F4860*6B*	G*E80905C**	41,000	31,200	14.00	12.20	37,900	30,700	39,000	8.20	23,000	1346682
	CA*F4860*6B*	G*E81155C**	41,000	31,200	14.00	12.20	37,900	30,700	39,000	8.20	23,000	1346683
	CA*F4860*6B*	G*V80905C**	41,000	31,200	14.00	12.20	37,900	30,700	39,000	8.20	23,000	1346684
	CA*F4860*6B*	G*V81155C**	41,000	31,200	14.00	12.20	37,900	30,700	39,000	8.20	23,000	1346685
	CA*F4860*6B*	G*V90905D**	41,000	31,200	13.50	11.80	37,900	30,700	39,000	8.00	23,000	1346686
	CA*F4860*6B*	G*V950905D**	41,000	31,200	13.50	11.80	37,900	30,700	39,000	8.00	23,000	1346687
	CA*F4860*6B*	G*V951155D**	41,000	31,200	13.50	11.80	37,900	30,700	39,000	8.00	23,000	1346688
	CHPF048D2*+EEP		40,000	30,400	13.00	11.50	37,000	30,000	39,000	8.00	23,000	735904
	CHPF060D2*	G*V80905C**	41,000	31,200	14.00	12.20	37,900	30,700	39,000	8.20	23,000	735071
	CHPF060D2*	G*V81155C**	41,000	31,200	14.00	12.20	37,900	30,700	39,000	8.20	23,000	735186
	CHPF060D2*	G*V90905D**	41,000	31,200	13.50	11.80	37,900	30,700	39,000	8.00	23,000	735153
	CHPF060D2*	G*V950905D**	41,000	31,200	13.50	11.80	37,900	30,700	39,000	8.00	23,000	735813
	CHPF060D2*	G*V951155D**	41,000	31,200	13.50	11.80	37,900	30,700	39,000	8.00	23,000	735989
	CHPF3642C6A*+EEP		40,000	30,400	13.00	11.50	37,000	30,000	39,000	8.00	23,000	735860
	CHPF3642C6B*+EEP		40,000	30,400	13.00	11.50	37,000	30,000	39,000	8.00	23,000	1330403
	CHPF3642D6A*+EEP		40,000	30,400	13.00	11.50	37,000	30,000	39,000	8.00	23,000	735906
	CHPF3642D6B*+EEP		40,000	30,400	13.00	11.50	37,000	30,000	39,000	8.00	23,000	1330404
	CHPF4860*6A*	G*E80905C**	41,000	31,200	14.00	12.20	37,900	30,700	39,000	8.20	23,000	1273345
	CHPF4860*6A*	G*E81155C**	41,000	31,200	14.00	12.20	37,900	30,700	39,000	8.20	23,000	1273359
	CHPF4860*6A*	G*V80905C**	41,000	31,200	14.00	12.20	37,900	30,700	39,000	8.20	23,000	735161
CHPF4860*6A*	G*V81155C**	41,000	31,200	14.00	12.20	37,900	30,700	39,000	8.20	23,000	735103	
CHPF4860*6A*	G*V90905D**	41,000	31,200	13.50	11.80	37,900	30,700	39,000	8.00	23,000	735135	

¹ Seasonal Energy Efficiency Ratio; Certified per ARI 210/240 @ 80°F/ 67°F/ 95°F

³ TVA Rating: BTU/h @ 75°F/ 63°F - 95°F

² Energy Efficiency Ratio @ 80°F/ 67°F/ 95°F

⁴ HSPF = Heating Seasonal Performance Factor

Notes:

- Always check the S&R plate for electrical data on the unit being installed.
- When matching the outdoor unit to the indoor unit, use the piston supplied with the outdoor unit or that specified on the piston kit chart supplied with the indoor unit.
- EEP - Order from Service Dept. Part No. B13707-38 or new Solid State Board B13707-35S. Part No. B13707-38 is not interchangeable with B13707-35S. The Goodman Gas Furnace contains the EEP cooling time delay

ARI PERFORMANCE RATINGS (CONT.)

Outdoor Unit	Indoor Units		Cooling (BTU/h)				TVA Ratings		Heating (BTU/h)			ARI #
	Indoor Coil	Furnace/ Blower	Total	Sens.	SEER ¹	EER ²	Total	Sens.	High	HSPF ³	Low	
GSH13 0421A* (cont.)	CHPF4860*6A*	G*V950905D**	41,000	31,200	13.50	11.80	37,900	30,700	39,000	8.00	23,000	735986
	CHPF4860*6A*	G*V951155D**	41,000	31,200	13.50	11.80	37,900	30,700	39,000	8.00	23,000	735994
	CHPF4860D6C*	G*E80905C**	41,000	31,200	14.00	12.20	37,900	30,700	39,000	8.20	23,000	1347595
	CHPF4860D6C*	G*E81155C**	41,000	31,200	14.00	12.20	37,900	30,700	39,000	8.20	23,000	1347596
	CHPF4860D6C*	G*V80905C**	41,000	31,200	14.00	12.20	37,900	30,700	39,000	8.20	23,000	1330405
	CHPF4860D6C*	G*V81155C**	41,000	31,200	14.00	12.20	37,900	30,700	39,000	8.20	23,000	1330406
	CHPF4860D6C*	G*V90905D**	41,000	31,200	13.50	11.80	37,900	30,700	39,000	8.00	23,000	1330407
	CHPF4860D6C*	G*V950905D**	41,000	31,200	13.50	11.80	37,900	30,700	39,000	8.00	23,000	1330408
	CHPF4860D6C*	G*V951155D**	41,000	31,200	13.50	11.80	37,900	30,700	39,000	8.00	23,000	1330409
	CSCF3642N6A*+EEP		40,000	30,400	13.00	11.50	37,000	30,000	39,000	8.00	23,000	735885
	CSCF3642N6C*+EEP		40,000	30,400	13.00	11.50	37,000	30,000	39,000	8.00	23,000	1296604
	CSCF4860N6A*	G*E80905C**	41,000	31,200	14.00	12.20	37,900	30,700	39,000	8.20	23,000	1273346
	CSCF4860N6A*	G*E81155C**	41,000	31,200	14.00	12.20	37,900	30,700	39,000	8.20	23,000	1273360
	CSCF4860N6A*	G*V80905C**	41,000	31,200	14.00	12.20	37,900	30,700	39,000	8.20	23,000	735221
	CSCF4860N6A*	G*V81155C**	41,000	31,200	14.00	12.20	37,900	30,700	39,000	8.20	23,000	735098
	CSCF4860N6A*	G*V90905D**	41,000	31,200	13.50	11.80	37,900	30,700	39,000	8.00	23,000	735062
	CSCF4860N6A*	G*V950905D**	41,000	31,200	13.50	11.80	37,900	30,700	39,000	8.00	23,000	735801
	CSCF4860N6A*	G*V951155D**	41,000	31,200	13.50	11.80	37,900	30,700	39,000	8.00	23,000	735980
	CSCF4860N6C*	G*E80905C**	41,000	31,200	14.00	12.20	37,900	30,700	39,000	8.20	23,000	1296619
	CSCF4860N6C*	G*E81155C**	41,000	31,200	14.00	12.20	37,900	30,700	39,000	8.20	23,000	1296620
	CSCF4860N6C*	G*V80905C**	41,000	31,200	14.00	12.20	37,900	30,700	39,000	8.20	23,000	1296621
	CSCF4860N6C*	G*V81155C**	41,000	31,200	14.00	12.20	37,900	30,700	39,000	8.20	23,000	1296622
	CSCF4860N6C*	G*V90905D**	41,000	31,200	13.50	11.80	37,900	30,700	39,000	8.00	23,000	1296623
	CSCF4860N6C*	G*V950905D**	41,000	31,200	13.50	11.80	37,900	30,700	39,000	8.00	23,000	1296624
	CSCF4860N6C*	G*V951155D**	41,000	31,200	13.50	11.80	37,900	30,700	39,000	8.00	23,000	1296625
	CT*F3642*6A*+EEP		40,000	30,400	13.00	11.50	37,000	30,000	39,000	8.00	23,000	1449951
	CT*F3642*6A*	MBE1600**-1	41,000	31,200	14.00	12.20	37,900	30,700	39,000	8.20	23,000	1449952
	CT*F4860*6A*	G*E80905C**	41,000	31,200	14.00	12.20	37,900	30,700	39,000	8.20	23,000	1449953
	CT*F4860*6A*	G*E81155C**	41,000	31,200	14.00	12.20	37,900	30,700	39,000	8.20	23,000	1449954
	CT*F4860*6A*	G*V80905C**	41,000	31,200	14.00	12.20	37,900	30,700	39,000	8.20	23,000	1449955
	CT*F4860*6A*	G*V81155C**	41,000	31,200	14.00	12.20	37,900	30,700	39,000	8.20	23,000	1449956
	CT*F4860*6A*	G*V90905D**	41,000	31,200	13.50	11.80	37,900	30,700	39,000	8.00	23,000	1449957
	CT*F4860*6A*	G*V950905D**	41,000	31,200	13.50	11.80	37,900	30,700	39,000	8.00	23,000	1449958
	CT*F4860*6A*	G*V951155D**	41,000	31,200	13.50	11.80	37,900	30,700	39,000	8.00	23,000	1449959
	H60F+EEP		40,000	30,400	13.00	11.50	37,000	30,000	39,000	8.00	23,000	735859
	H61F	G*V80905C**	41,000	31,200	14.00	12.20	37,900	30,700	39,000	8.20	23,000	735178
	H61F	G*V81155C**	41,000	31,200	14.00	12.20	37,900	30,700	39,000	8.20	23,000	735089
	H61F	G*V90905D**	41,000	31,200	13.50	11.80	37,900	30,700	39,000	8.00	23,000	735164
	H61F	G*V950905D**	41,000	31,200	13.50	11.80	37,900	30,700	39,000	8.00	23,000	735101
	H61F	G*V951155D**	41,000	31,200	13.50	11.80	37,900	30,700	39,000	8.00	23,000	735979
GSH13 0481A*	ADPF486016A*		45,000	34,200	13.00	11.50	41,600	33,700	43,000	8.20	27,000	1038071
	ADPF486016B*		45,000	34,200	13.00	11.50	41,600	33,700	43,000	8.20	27,000	1492562
	ADPF48601A*		45,000	34,200	13.00	11.50	41,600	33,700	43,000	8.20	27,000	735140
	ADPF48601B*		45,000	34,200	13.00	11.50	41,600	33,700	43,000	8.20	27,000	1069239
	AEPF426016A*		45,000	34,200	14.00	12.20	41,600	33,700	43,000	8.40	27,000	1038072
	AEPF426016B*		45,000	34,200	14.00	12.20	41,600	33,700	43,000	8.40	27,000	1277847
	AEPF426016C*		45,000	34,200	14.00	12.20	41,600	33,700	43,000	8.40	27,000	1492563
	AEPF42601A*		45,000	34,200	14.00	12.20	41,600	33,700	43,000	8.40	27,000	735224
	AEPF42601B*		45,000	34,200	14.00	12.20	41,600	33,700	43,000	8.40	27,000	1069227
	AEPT060-00*-1*		45,000	34,200	14.00	12.20	41,600	33,700	43,000	8.40	27,000	735091

See Notes on Page 58.

ARI PERFORMANCE RATINGS (CONT.)

Outdoor Unit	Indoor Units		Cooling (BTU/h)				TVA Ratings		Heating (BTU/h)			ARI #
	Indoor Coil	Furnace/ Blower	Total	Sens.	SEER ¹	EER ²	Total	Sens.	High	HSPF ³	Low	
GSH13 0481A* (cont.)	AR*F486016B*		45,000	34,200	13.00	11.50	41,600	33,700	43,000	8.20	27,000	1492564
	ARPF060-00B-1*		45,000	34,200	13.00	11.50	41,600	33,700	43,000	8.20	27,000	735058
	ARPF486016A*		45,000	34,200	13.00	11.50	41,600	33,700	43,000	8.20	27,000	1038073
	ARPF48601A*		45,000	34,200	13.00	11.50	41,600	33,700	43,000	8.20	27,000	735227
	ARPF48601B*		45,000	34,200	13.00	11.50	41,600	33,700	43,000	8.20	27,000	1069228
	ARPT061-00*-1*		45,000	34,200	13.00	11.50	41,600	33,700	43,000	8.20	27,000	735172
	ARUF061-00*-1*		45,000	34,200	13.00	11.50	41,600	33,700	43,000	8.20	27,000	735130
	ARUF486016A*		45,000	34,200	13.00	11.50	41,600	33,700	43,000	8.20	27,000	1038074
	ARUF48601A*		45,000	34,200	13.00	11.50	41,600	33,700	43,000	8.20	27,000	735225
	ARUF48601B*		45,000	34,200	13.00	11.50	41,600	33,700	43,000	8.20	27,000	1069229
	ASPF426016A*		45,000	34,200	14.00	12.20	41,600	33,700	43,000	8.40	27,000	1291682
	ASPF426016B*		45,000	34,200	14.00	12.20	41,600	33,700	43,000	8.40	27,000	1492565
	AT*F486016A*		45,000	34,200	13.00	11.50	41,600	33,700	43,000	8.20	27,000	1483534
	CA*F061*2*	G*V80905C**	45,000	34,200	13.50	11.80	41,600	33,700	43,000	8.30	27,000	735245
	CA*F061*2*	G*V81155C**	45,000	34,200	14.00	12.20	41,600	33,700	43,000	8.40	27,000	735220
	CA*F061*2*	G*V90905D**	45,000	34,200	13.50	11.80	41,600	33,700	43,000	8.30	27,000	735133
	CA*F061*2*	G*V950905D**	45,000	34,200	13.50	11.80	41,600	33,700	43,000	8.30	27,000	735080
	CA*F061*2*	G*V951155D**	45,000	34,200	13.50	11.80	41,600	33,700	43,000	8.30	27,000	735138
	CA*F061*2*+EEP		45,000	34,200	13.00	11.50	41,600	33,700	43,000	8.20	27,000	735891
	CA*F061*2*	MBE2000**-1	45,000	34,200	14.00	12.20	41,600	33,700	43,000	8.40	27,000	1032331
	CA*F4860*6A*	G*E80905C**	45,000	34,200	13.50	11.80	41,600	33,700	43,000	8.30	27,000	1273347
	CA*F4860*6A*	G*E81155C**	45,000	34,200	13.50	11.80	41,600	33,700	43,000	8.30	27,000	1273361
	CA*F4860*6A*	G*V80905C**	45,000	34,200	13.50	11.80	41,600	33,700	43,000	8.30	27,000	735092
	CA*F4860*6A*	G*V81155C**	45,000	34,200	14.00	12.20	41,600	33,700	43,000	8.40	27,000	735213
	CA*F4860*6A*	G*V90905D**	45,000	34,200	13.50	11.80	41,600	33,700	43,000	8.30	27,000	735998
	CA*F4860*6A*	G*V950905D**	45,000	34,200	13.50	11.80	41,600	33,700	43,000	8.30	27,000	735179
	CA*F4860*6A*	G*V951155D**	45,000	34,200	13.50	11.80	41,600	33,700	43,000	8.30	27,000	735107
	CA*F4860*6A*+EEP		45,000	34,200	13.00	11.50	41,600	33,700	43,000	8.20	27,000	735858
	CA*F4860*6A*	MBE2000**-1	45,000	34,200	14.00	12.20	41,600	33,700	43,000	8.40	27,000	1032333
	CA*F4860*6B*	G*E80905C**	45,000	34,200	13.50	11.80	41,600	33,700	43,000	8.30	27,000	1346689
	CA*F4860*6B*	G*E81155C**	45,000	34,200	13.50	11.80	41,600	33,700	43,000	8.30	27,000	1346690
	CA*F4860*6B*	G*V80905C**	45,000	34,200	13.50	11.80	41,600	33,700	43,000	8.30	27,000	1346691
	CA*F4860*6B*	G*V81155C**	45,000	34,200	14.00	12.20	41,600	33,700	43,000	8.40	27,000	1346692
	CA*F4860*6B*	G*V90905D**	45,000	34,200	13.50	11.80	41,600	33,700	43,000	8.30	27,000	1346693
	CA*F4860*6B*	G*V950905D**	45,000	34,200	13.50	11.80	41,600	33,700	43,000	8.30	27,000	1346694
	CA*F4860*6B*	G*V951155D**	45,000	34,200	13.50	11.80	41,600	33,700	43,000	8.30	27,000	1346695
	CA*F4860*6B*+EEP		45,000	34,200	13.00	11.50	41,600	33,700	43,000	8.20	27,000	1347208
	CA*F4860*6B*	MBE2000**-1	45,000	34,200	14.00	12.20	41,600	33,700	43,000	8.40	27,000	1346696
	CHPF060D2*	G*V80905C**	45,000	34,200	13.50	11.80	41,600	33,700	43,000	8.30	27,000	735057
	CHPF060D2*	G*V81155C**	45,000	34,200	13.50	11.80	41,600	33,700	43,000	8.30	27,000	735160
	CHPF060D2*	G*V90905D**	45,000	34,200	13.50	11.80	41,600	33,700	43,000	8.30	27,000	735052
	CHPF060D2*	G*V950905D**	45,000	34,200	13.50	11.80	41,600	33,700	43,000	8.30	27,000	736534
	CHPF060D2*	G*V951155D**	45,000	34,200	13.50	11.80	41,600	33,700	43,000	8.30	27,000	736530
	CHPF060D2*+EEP		45,000	34,200	13.00	11.50	41,600	33,700	43,000	8.20	27,000	735882
	CHPF4860D6A*	G*E80905C**	45,000	34,200	13.50	11.80	41,600	33,700	43,000	8.30	27,000	1273348
	CHPF4860D6A*	G*E81155C**	45,000	34,200	13.50	11.80	41,600	33,700	43,000	8.30	27,000	1273362
	CHPF4860D6A*	G*V80905C**	45,000	34,200	13.50	11.80	41,600	33,700	43,000	8.30	27,000	735102
	CHPF4860D6A*	G*V81155C**	45,000	34,200	13.50	11.80	41,600	33,700	43,000	8.30	27,000	735051
CHPF4860D6A*	G*V90905D**	45,000	34,200	13.50	11.80	41,600	33,700	43,000	8.30	27,000	735200	
CHPF4860D6A*	G*V950905D**	45,000	34,200	13.50	11.80	41,600	33,700	43,000	8.30	27,000	736529	

See Notes on Page 58.

ARI PERFORMANCE RATINGS (CONT.)

Outdoor Unit	Indoor Units		Cooling (BTU/h)				TVA Ratings		Heating (BTU/h)			ARI #
	Indoor Coil	Furnace/ Blower	Total	Sens.	SEER ¹	EER ²	Total	Sens.	High	HSPF ³	Low	
GSH13 0481A* (cont.)	CHPF4860D6A*	G*V951155D**	45,000	34,200	13.50	11.80	41,600	33,700	43,000	8.30	27,000	736540
	CHPF4860D6A*+EEP		45,000	34,200	13.00	11.50	41,600	33,700	43,000	8.20	27,000	735881
	CHPF4860D6A*	MBE2000**-1	45,000	34,200	14.00	12.20	41,600	33,700	45,000	8.50	26,000	1069387
	CHPF4860D6C*	G*E80905C**	45,000	34,200	13.50	11.80	41,600	33,700	43,000	8.30	27,000	1347598
	CHPF4860D6C*	G*E81155C**	45,000	34,200	13.50	11.80	41,600	33,700	43,000	8.30	27,000	1347599
	CHPF4860D6C*	G*V80905C**	45,000	34,200	13.50	11.80	41,600	33,700	43,000	8.30	27,000	1330410
	CHPF4860D6C*	G*V81155C**	45,000	34,200	13.50	11.80	41,600	33,700	43,000	8.30	27,000	1330411
	CHPF4860D6C*	G*V90905D**	45,000	34,200	13.50	11.80	41,600	33,700	43,000	8.30	27,000	1330412
	CHPF4860D6C*	G*V950905D**	45,000	34,200	13.50	11.80	41,600	33,700	43,000	8.30	27,000	1330413
	CHPF4860D6C*	G*V951155D**	45,000	34,200	13.50	11.80	41,600	33,700	43,000	8.30	27,000	1330414
	CHPF4860D6C*+EEP		45,000	34,200	13.00	11.50	41,600	33,700	43,000	8.20	27,000	1330415
	CHPF4860D6C*	MBE2000**-1	45,000	34,200	14.00	12.20	41,600	33,700	45,000	8.50	26,000	1347597
	CHPF4860D6C*+TXV	MBE2000**-1B*	45,500	34,600	14.50	12.00	42,100	34,100	45,000	8.50	26,000	1411924
	CSCF4860N6A*	G*E80905C**	45,000	34,200	13.50	11.80	41,600	33,700	43,000	8.30	27,000	1273349
	CSCF4860N6A*	G*E81155C**	45,000	34,200	13.50	11.80	41,600	33,700	43,000	8.30	27,000	1273363
	CSCF4860N6A*	G*V80905C**	45,000	34,200	13.50	11.80	41,600	33,700	43,000	8.30	27,000	735055
	CSCF4860N6A*	G*V81155C**	45,000	34,200	13.50	11.80	41,600	33,700	43,000	8.30	27,000	735237
	CSCF4860N6A*	G*V90905D**	45,000	34,200	13.50	11.80	41,600	33,700	43,000	8.30	27,000	735203
	CSCF4860N6A*	G*V950905D**	45,000	34,200	13.50	11.80	41,600	33,700	43,000	8.30	27,000	736531
	CSCF4860N6A*	G*V951155D**	45,000	34,200	13.50	11.80	41,600	33,700	43,000	8.30	27,000	736541
	CSCF4860N6A*+EEP		45,000	34,200	13.00	11.50	41,600	33,700	43,000	8.20	27,000	735879
	CSCF4860N6C*	G*E80905C**	45,000	34,200	13.50	11.80	41,600	33,700	43,000	8.30	27,000	1296626
	CSCF4860N6C*	G*E81155C**	45,000	34,200	13.50	11.80	41,600	33,700	43,000	8.30	27,000	1296627
	CSCF4860N6C*	G*V80905C**	45,000	34,200	13.50	11.80	41,600	33,700	43,000	8.30	27,000	1296628
	CSCF4860N6C*	G*V81155C**	45,000	34,200	13.50	11.80	41,600	33,700	43,000	8.30	27,000	1296629
	CSCF4860N6C*	G*V90905D**	45,000	34,200	13.50	11.80	41,600	33,700	43,000	8.30	27,000	1296630
	CSCF4860N6C*	G*V950905D**	45,000	34,200	13.50	11.80	41,600	33,700	43,000	8.30	27,000	1296631
	CSCF4860N6C*	G*V951155D**	45,000	34,200	13.50	11.80	41,600	33,700	43,000	8.30	27,000	1296632
	CSCF4860N6C*+EEP		45,000	34,200	13.00	11.50	41,600	33,700	43,000	8.20	27,000	1296633
	CT*F4860*6A*	G*E80905C**	45,000	34,200	13.50	11.80	41,600	33,700	43,000	8.30	27,000	1449960
	CT*F4860*6A*	G*E81155C**	45,000	34,200	13.50	11.80	41,600	33,700	43,000	8.30	27,000	1449961
	CT*F4860*6A*	G*V80905C**	45,000	34,200	13.50	11.80	41,600	33,700	43,000	8.30	27,000	1449962
	CT*F4860*6A*	G*V81155C**	45,000	34,200	14.00	12.20	41,600	33,700	43,000	8.40	27,000	1449963
	CT*F4860*6A*	G*V90905D**	45,000	34,200	13.50	11.80	41,600	33,700	43,000	8.30	27,000	1449964
	CT*F4860*6A*	G*V950905D**	45,000	34,200	13.50	11.80	41,600	33,700	43,000	8.30	27,000	1449965
	CT*F4860*6A*	G*V951155D**	45,000	34,200	13.50	11.80	41,600	33,700	43,000	8.30	27,000	1449966
	CT*F4860*6A*+EEP		45,000	34,200	13.00	11.50	41,600	33,700	43,000	8.20	27,000	1449967
	CT*F4860*6A*	MBE2000**-1	45,000	34,200	14.00	12.20	41,600	33,700	43,000	8.40	27,000	1449968
	H61F	G*V80905C**	45,000	34,200	13.50	11.80	41,600	33,700	43,000	8.30	27,000	735139
	H61F	G*V81155C**	45,000	34,200	13.50	11.80	41,600	33,700	43,000	8.30	27,000	735075
	H61F	G*V90905D**	45,000	34,200	13.50	11.80	41,600	33,700	43,000	8.30	27,000	735066
	H61F	G*V950905D**	45,000	34,200	13.50	11.80	41,600	33,700	43,000	8.30	27,000	736532
H61F	G*V951155D**	45,000	34,200	13.50	11.80	41,600	33,700	43,000	8.30	27,000	736535	
H61F+EEP		45,000	34,200	13.00	11.50	41,600	33,700	43,000	8.20	27,000	735862	
GSH13 0483A*	ADPF486016A*		45,000	34,200	13.00	11.50	41,600	33,700	43,000	8.20	27,000	1038085
	ADPF486016B*		45,000	34,200	13.00	11.50	41,600	33,700	43,000	8.20	27,000	1492566
	ADPF48601A*		45,000	34,200	13.00	11.50	41,600	33,700	43,000	8.20	27,000	872433
	ADPF48601B*		45,000	34,200	13.00	11.50	41,600	33,700	43,000	8.20	27,000	1069230
	AEPF426016A*		45,000	34,200	14.00	12.20	41,600	33,700	43,000	8.40	27,000	1038098
	AEPF426016B*		45,000	34,200	14.00	12.20	41,600	33,700	43,000	8.40	27,000	1277848

See Notes on Page 65.

ARI PERFORMANCE RATINGS (CONT.)

Outdoor Unit	Indoor Units		Cooling (BTU/h)				TVA Ratings		Heating (BTU/h)			ARI #
	Indoor Coil	Furnace/ Blower	Total	Sens.	SEER ¹	EER ²	Total	Sens.	High	HSPF ³	Low	
GSH13 0483A* (cont.)	AEPF426016C*		45,000	34,200	14.00	12.20	41,600	33,700	43,000	8.40	27,000	1492567
	AEPF42601A*		45,000	34,200	14.00	12.20	41,600	33,700	43,000	8.40	27,000	872423
	AEPF42601B*		45,000	34,200	14.00	12.20	41,600	33,700	43,000	8.40	27,000	1069231
	AEPT060-00*-1*		45,000	34,200	14.00	12.20	41,600	33,700	43,000	8.40	27,000	872409
	AR*F486016B*		45,000	34,200	13.00	11.50	41,600	33,700	43,000	8.20	27,000	1492568
	ARPF060-00B-1*		45,000	34,200	13.00	11.50	41,600	33,700	43,000	8.20	27,000	872416
	ARPF486016A*		45,000	34,200	13.00	11.50	41,600	33,700	43,000	8.20	27,000	1038097
	ARPF48601A*		45,000	34,200	13.00	11.50	41,600	33,700	43,000	8.20	27,000	872438
	ARPF48601B*		45,000	34,200	13.00	11.50	41,600	33,700	43,000	8.20	27,000	1069237
	ARPT061-00*-1*		45,000	34,200	13.00	11.50	41,600	33,700	43,000	8.20	27,000	872432
	ARUF061-00*-1*		45,000	34,200	13.00	11.50	41,600	33,700	43,000	8.20	27,000	872439
	ARUF486016A*		45,000	34,200	13.00	11.50	41,600	33,700	43,000	8.20	27,000	1038096
	ARUF48601A*		45,000	34,200	13.00	11.50	41,600	33,700	43,000	8.20	27,000	872436
	ARUF48601B*		45,000	34,200	13.00	11.50	41,600	33,700	43,000	8.20	27,000	1069236
	ASPF426016A*		45,000	34,200	14.00	12.20	41,600	33,700	43,000	8.40	27,000	1291686
	ASPF426016B*		45,000	34,200	14.00	12.20	41,600	33,700	43,000	8.40	27,000	1492569
	AT*F486016A*		45,000	34,200	13.00	11.50	41,600	33,700	43,000	8.20	27,000	1483535
	CA*F061*2*+EEP		45,000	34,200	13.00	11.50	41,600	33,700	43,000	8.20	27,000	869429
	CA*F4860*6A*+EEP		45,000	34,200	13.00	11.50	41,600	33,700	43,000	8.20	27,000	869455
	CA*F4860*6B*+EEP		45,000	34,200	13.00	11.50	41,600	33,700	43,000	8.20	27,000	1347209
	CHPF060D2*+EEP		45,000	34,200	13.00	11.50	41,600	33,700	43,000	8.20	27,000	869452
	CHPF4860D6A*+EEP		45,000	34,200	13.00	11.50	41,600	33,700	43,000	8.20	27,000	869446
	CHPF4860D6C*+EEP		45,000	34,200	13.00	11.50	41,600	33,700	43,000	8.20	27,000	1330416
	CSCF4860N6A*+EEP		45,000	34,200	13.00	11.50	41,600	33,700	43,000	8.20	27,000	869439
	CSCF4860N6C*+EEP		45,000	34,200	13.00	11.50	41,600	33,700	43,000	8.20	27,000	1296634
	CT*F4860*6A*+EEP		45,000	34,200	13.00	11.50	41,600	33,700	43,000	8.20	27,000	1449969
H61F+EEP		45,000	34,200	13.00	11.50	41,600	33,700	43,000	8.20	27,000	869453	
GSH13 0484A*	ADPF486016A*		45,000	33,800	13.00	11.50	41,600	33,300	43,000	8.20	27,000	1038095
	ADPF486016B*		45,000	33,800	13.00	11.50	41,600	33,300	43,000	8.20	27,000	1492570
	ADPF48601A*		45,000	33,800	13.00	11.50	41,600	33,300	43,000	8.20	27,000	872413
	ADPF48601B*		45,000	33,800	13.00	11.50	41,600	33,300	43,000	8.20	27,000	1069235
	AEPF426016A*		45,000	33,800	14.00	12.20	41,600	33,300	43,000	8.40	27,000	1038094
	AEPF426016B*		45,000	33,800	14.00	12.20	41,600	33,300	43,000	8.40	27,000	1277849
	AEPF426016C*		45,000	33,800	14.00	12.20	41,600	33,300	43,000	8.40	27,000	1492571
	AEPF42601A*		45,000	33,800	14.00	12.20	41,600	33,300	43,000	8.40	27,000	872414
	AEPF42601B*		45,000	33,800	14.00	12.20	41,600	33,300	43,000	8.40	27,000	1069234
	AEPT060-00*-1*		45,000	33,800	14.00	12.20	41,600	33,300	43,000	8.40	27,000	872421
	AR*F486016B*		45,000	33,800	13.00	11.50	41,600	33,300	43,000	8.20	27,000	1492572
	ARPF060-00B-1*		45,000	33,800	13.00	11.50	41,600	33,300	43,000	8.20	27,000	872428
	ARPF486016A*		45,000	33,800	13.00	11.50	41,600	33,300	43,000	8.20	27,000	1038093
	ARPF48601A*		45,000	33,800	13.00	11.50	41,600	33,300	43,000	8.20	27,000	872429
	ARPF48601B*		45,000	33,800	13.00	11.50	41,600	33,300	43,000	8.20	27,000	1069233
	ARPT061-00*-1*		45,000	33,800	13.00	11.50	41,600	33,300	43,000	8.20	27,000	872435
	ARUF061-00*-1*		45,000	33,800	13.00	11.50	41,600	33,300	43,000	8.20	27,000	872419
	ARUF486016A*		45,000	33,800	13.00	11.50	41,600	33,300	43,000	8.20	27,000	1038092
	ARUF48601A*		45,000	33,800	13.00	11.50	41,600	33,300	43,000	8.20	27,000	872426
	ARUF48601B*		45,000	33,800	13.00	11.50	41,600	33,300	43,000	8.20	27,000	1069232
	ASPF426016A*		45,000	33,800	14.00	12.20	41,600	33,300	43,000	8.40	27,000	1291688
	ASPF426016B*		45,000	33,800	14.00	12.20	41,600	33,300	43,000	8.40	27,000	1492573
AT*F486016A*		45,000	33,800	13.00	11.50	41,600	33,300	43,000	8.20	27,000	1483536	

See Notes on Page 65.

ARI PERFORMANCE RATINGS (CONT.)

Outdoor Unit	Indoor Units		Cooling (BTU/h)				TVA Ratings		Heating (BTU/h)			ARI #
	Indoor Coil	Furnace/ Blower	Total	Sens.	SEER ¹	EER ²	Total	Sens.	High	HSPF ³	Low	
GSH13 0484A* (cont.)	CA*F061*2*+EEP		45,000	33,800	13.00	11.50	41,600	33,300	43,000	8.20	27,000	869477
	CA*F4860*6A*+EEP		45,000	33,800	13.00	11.50	41,600	33,300	43,000	8.20	27,000	869476
	CA*F4860*6B*+EEP		45,000	33,800	13.00	11.50	41,600	33,300	43,000	8.20	27,000	1347210
	CHPF060D2*+EEP		45,000	33,800	13.00	11.50	41,600	33,300	43,000	8.20	27,000	869472
	CHPF4860D6A*+EEP		45,000	33,800	13.00	11.50	41,600	33,300	43,000	8.20	27,000	869447
	CHPF4860D6C*+EEP		45,000	33,800	13.00	11.50	41,600	33,300	43,000	8.20	27,000	1330417
	CSCF4860N6A*+EEP		45,000	33,800	13.00	11.50	41,600	33,300	43,000	8.20	27,000	869443
	CSCF4860N6C*+EEP		45,000	33,800	13.00	11.50	41,600	33,300	43,000	8.20	27,000	1296635
	CT*F4860*6A*+EEP		45,000	33,800	13.00	11.50	41,600	33,300	43,000	8.20	27,000	1449970
	H61F+EEP		45,000	33,800	13.00	11.50	41,600	33,300	43,000	8.20	27,000	869434
GSH13 0601A*	ADPF486016A*		55,500	40,000	13.00	11.50	51,300	39,500	55,500	8.50	35,000	1038075
	ADPF486016B*		55,500	40,000	13.00	11.50	51,300	39,500	55,500	8.50	35,000	1492574
	ADPF48601A*		55,500	40,000	13.00	11.50	51,300	39,500	55,500	8.50	35,000	735212
	ADPF48601B*		55,500	40,000	13.00	11.50	51,300	39,500	55,500	8.50	35,000	1069190
	AEPF426016A*		55,500	40,000	13.30	11.70	51,300	39,500	55,500	8.60	35,000	1038076
	AEPF426016B*		55,500	40,000	13.30	11.70	51,300	39,500	55,500	8.60	35,000	1277850
	AEPF426016C*		55,500	40,000	13.30	11.70	51,300	39,500	55,500	8.60	35,000	1492575
	AEPF42601A*		55,500	40,000	13.30	11.70	51,300	39,500	55,500	8.60	35,000	735084
	AEPF42601B*		55,500	40,000	13.30	11.70	51,300	39,500	55,500	8.60	35,000	1069191
	AEPT060-00*-1*		55,500	40,000	13.30	11.70	51,300	39,500	55,500	8.60	35,000	735069
	AR*F486016B*		55,500	40,000	13.00	11.50	51,300	39,500	55,500	8.50	35,000	1492576
	ARPF060-00B-1*		55,500	40,000	13.00	11.50	51,300	39,500	55,500	8.50	35,000	735163
	ARPF486016A*		55,500	40,000	13.00	11.50	51,300	39,500	55,500	8.50	35,000	1038077
	ARPF48601A*		55,500	40,000	13.00	11.50	51,300	39,500	55,500	8.50	35,000	735083
	ARPF48601B*		55,500	40,000	13.00	11.50	51,300	39,500	55,500	8.50	35,000	1069192
	ARPT061-00*-1*		55,500	40,000	13.00	11.50	51,300	39,500	55,500	8.50	35,000	735192
	ARUF061-00*-1*		55,500	40,000	13.00	11.50	51,300	39,500	55,500	8.50	35,000	735167
	ARUF486016A*		55,500	40,000	13.00	11.50	51,300	39,500	55,500	8.50	35,000	1038078
	ARUF48601A*		55,500	40,000	13.00	11.50	51,300	39,500	55,500	8.50	35,000	735214
	ARUF48601B*		55,500	40,000	13.00	11.50	51,300	39,500	55,500	8.50	35,000	1069193
	ASPF426016A*		55,500	40,000	13.30	11.70	51,300	39,500	55,500	8.60	35,000	1291687
	ASPF426016A*+TXV		55,500	40,000	14.00	12.20	51,300	39,500	55,500	8.60	35,000	1292150
	ASPF426016B*		55,500	40,000	13.30	11.70	51,300	39,500	55,500	8.60	35,000	1492577
	ASPF426016B*+TXV		55,500	40,000	14.00	12.20	51,300	39,500	55,500	8.60	35,000	1492578
	AT*F486016A*		55,500	40,000	13.00	11.50	51,300	39,500	55,500	8.50	35,000	1483537
	CA*F061*2*	G*V80905C**	55,500	40,000	13.30	11.70	51,300	39,500	55,500	8.50	35,000	735199
	CA*F061*2*	G*V81155C**	55,500	40,000	13.30	11.70	51,300	39,500	55,500	8.50	35,000	735251
	CA*F061*2*+EEP		55,500	40,000	13.00	11.50	51,300	39,500	55,500	8.50	35,000	735873
	CA*F061*2	MBE2000**-1	55,500	40,000	13.50	11.80	51,300	39,500	55,500	8.60	35,000	1032334
	CA*F4860*6A*	G*V80905C**	55,500	40,000	13.30	11.70	51,300	39,500	55,500	8.50	35,000	735149
	CA*F4860*6A*	G*V81155C**	55,500	40,000	13.30	11.70	51,300	39,500	55,500	8.50	35,000	735148
	CA*F4860*6A*+EEP		55,500	40,000	13.00	11.50	51,300	39,500	55,500	8.50	35,000	735870
	CA*F4860*6A*	MBE2000**-1	55,500	40,000	13.50	11.80	51,300	39,500	55,500	8.60	35,000	1032332
	CA*F4860*6B*	G*V80905C**	55,500	40,000	13.30	11.70	51,300	39,500	55,500	8.50	35,000	1346697
	CA*F4860*6B*	G*V81155C**	55,500	40,000	13.30	11.70	51,300	39,500	55,500	8.50	35,000	1346698
	CA*F4860*6B*+EEP		55,500	40,000	13.00	11.50	51,300	39,500	55,500	8.50	35,000	1347211
	CA*F4860*6B*	MBE2000**-1	55,500	40,000	13.50	11.80	51,300	39,500	55,500	8.60	35,000	1346699
	CHPF060D2*	G*V80905C**	55,500	40,000	13.30	11.70	51,300	39,500	55,500	8.50	35,000	735195
	CHPF060D2*	G*V81155C**	55,500	40,000	13.30	11.70	51,300	39,500	55,500	8.50	35,000	735046
	CHPF060D2*+EEP		55,500	40,000	13.00	11.50	51,300	39,500	55,500	8.50	35,000	735907

See Notes on Page 65.

ARI PERFORMANCE RATINGS (CONT.)

Outdoor Unit	Indoor Units		Cooling (BTU/h)				TVA Ratings		Heating (BTU/h)			ARI #
	Indoor Coil	Furnace/ Blower	Total	Sens.	SEER ¹	EER ²	Total	Sens.	High	HSPF ³	Low	
GSH13 0601A* (cont.)	CHPF4860*6A*	G*V80905C**	55,500	40,000	13.30	11.70	51,300	39,500	55,500	8.50	35,000	735137
	CHPF4860*6A*	G*V81155C**	55,500	40,000	13.30	11.70	51,300	39,500	55,500	8.50	35,000	735154
	CHPF4860D6A*+EEP		55,500	40,000	13.00	11.50	51,300	39,500	55,500	8.50	35,000	735911
	CHPF4860D6C*	G*V80905C**	55,500	40,000	13.30	11.70	51,300	39,500	55,500	8.50	35,000	1330418
	CHPF4860D6C*	G*V81155C**	55,500	40,000	13.30	11.70	51,300	39,500	55,500	8.50	35,000	1330419
	CHPF4860D6C*+EEP		55,500	40,000	13.00	11.50	51,300	39,500	55,500	8.50	35,000	1330420
	CSCF4860N6A*	G*V80905C**	55,500	40,000	13.30	11.70	51,300	39,500	55,500	8.50	35,000	735124
	CSCF4860N6A*	G*V81155C**	55,500	40,000	13.30	11.70	51,300	39,500	55,500	8.50	35,000	735110
	CSCF4860N6A*+EEP		55,500	40,000	13.00	11.50	51,300	39,500	55,500	8.50	35,000	735855
	CSCF4860N6C*	G*V80905C**	55,500	40,000	13.30	11.70	51,300	39,500	55,500	8.50	35,000	1296636
	CSCF4860N6C*	G*V81155C**	55,500	40,000	13.30	11.70	51,300	39,500	55,500	8.50	35,000	1296637
	CSCF4860N6C*+EEP		55,500	40,000	13.00	11.50	51,300	39,500	55,500	8.50	35,000	1296638
	CT*F4860*6A*	G*V80905C**	55,500	40,000	13.30	11.70	51,300	39,500	55,500	8.50	35,000	1449971
	CT*F4860*6A*	G*V81155C**	55,500	40,000	13.30	11.70	51,300	39,500	55,500	8.50	35,000	1449972
	CT*F4860*6A*+EEP		55,500	40,000	13.00	11.50	51,300	39,500	55,500	8.50	35,000	1449973
	CT*F4860*6A*	MBE2000*-1	55,500	40,000	13.50	11.80	51,300	39,500	55,500	8.60	35,000	1449974
	H61F	G*V80905C**	55,500	40,000	13.30	11.70	51,300	39,500	55,500	8.50	35,000	735043
	H61F	G*V81155C**	55,500	40,000	13.30	11.70	51,300	39,500	55,500	8.50	35,000	735145
	H61F+EEP		55,500	40,000	13.00	11.50	51,300	39,500	55,500	8.50	35,000	735910
	GSH13 0603A*	ADPF486016A*		55,500	40,000	13.00	11.50	51,300	39,500	55,500	8.50	35,000
ADPF486016B*			55,500	40,000	13.00	11.50	51,300	39,500	55,500	8.50	35,000	1492579
ADPF48601A*			55,500	40,000	13.00	11.50	51,300	39,500	55,500	8.50	35,000	872420
ADPF48601B*			55,500	40,000	13.00	11.50	51,300	39,500	55,500	8.50	35,000	1069194
AEPF426016A*			55,500	40,000	13.30	11.70	51,300	39,500	55,500	8.60	35,000	1038090
AEPF426016B*			55,500	40,000	13.30	11.70	51,300	39,500	55,500	8.60	35,000	1277851
AEPF426016C*			55,500	40,000	13.30	11.70	51,300	39,500	55,500	8.60	35,000	1492580
AEPF42601A*			55,500	40,000	13.30	11.70	51,300	39,500	55,500	8.60	35,000	872415
AEPF42601B*			55,500	40,000	13.30	11.70	51,300	39,500	55,500	8.60	35,000	1069195
AEPT060-00*-1*			55,500	40,000	13.30	11.70	51,300	39,500	55,500	8.60	35,000	872418
AR*F486016B*			55,500	40,000	13.00	11.50	51,300	39,500	55,500	8.50	35,000	1492581
ARPF060-00B-1*			55,500	40,000	13.00	11.50	51,300	39,500	55,500	8.50	35,000	872408
ARPF486016A*			55,500	40,000	13.00	11.50	51,300	39,500	55,500	8.50	35,000	1038089
ARPF48601A*			55,500	40,000	13.00	11.50	51,300	39,500	55,500	8.50	35,000	872424
ARPF48601B*			55,500	40,000	13.00	11.50	51,300	39,500	55,500	8.50	35,000	1069196
ARPT061-00*-1*			55,500	40,000	13.00	11.50	51,300	39,500	55,500	8.50	35,000	872417
ARUF061-00*-1*			55,500	40,000	13.00	11.50	51,300	39,500	55,500	8.50	35,000	872427
ARUF486016A*			55,500	40,000	13.00	11.50	51,300	39,500	55,500	8.50	35,000	1038082
ARUF48601A*			55,500	40,000	13.00	11.50	51,300	39,500	55,500	8.50	35,000	872411
ARUF48601B*			55,500	40,000	13.00	11.50	51,300	39,500	55,500	8.50	35,000	1069197
ASPF426016A*			55,500	40,000	13.30	11.70	51,300	39,500	55,500	8.60	35,000	1291685
ASPF426016B*			55,500	40,000	13.30	11.70	51,300	39,500	55,500	8.60	35,000	1492582
AT*F486016A*			55,500	40,000	13.00	11.50	51,300	39,500	55,500	8.50	35,000	1483538
CA*F061*2*+EEP			55,500	40,000	13.00	11.50	51,300	39,500	55,500	8.50	35,000	869428
CA*F4860*6A*+EEP			55,500	40,000	13.00	11.50	51,300	39,500	55,500	8.50	35,000	869433
CA*F4860*6B*+EEP			55,500	40,000	13.00	11.50	51,300	39,500	55,500	8.50	35,000	1347212
CHPF060D2*+EEP			55,500	40,000	13.00	11.50	51,300	39,500	55,500	8.50	35,000	869435
CHPF4860D6A*+EEP			55,500	40,000	13.00	11.50	51,300	39,500	55,500	8.50	35,000	869479
CHPF4860D6C*+EEP			55,500	40,000	13.00	11.50	51,300	39,500	55,500	8.50	35,000	1330421
CSCF4860N6A*+EEP			55,500	40,000	13.00	11.50	51,300	39,500	55,500	8.50	35,000	869478
CSCF4860N6C*+EEP			55,500	40,000	13.00	11.50	51,300	39,500	55,500	8.50	35,000	1296639
CT*F4860*6A*+EEP			55,500	40,000	13.00	11.50	51,300	39,500	55,500	8.50	35,000	1449975
H61F+EEP			55,500	40,000	13.00	11.50	51,300	39,500	55,500	8.50	35,000	869466

See Notes on Page 65.

ARI PERFORMANCE RATINGS (CONT.)

Outdoor Unit	Indoor Units		Cooling (BTU/h)				TVA Ratings		Heating (BTU/h)			ARI #
	Indoor Coil	Furnace/ Blower	Total	Sens.	SEER ¹	EER ²	Total	Sens.	High	HSPF ³	Low	
GSH13 0604A*	ADPF486016A*		55,500	40,000	13.00	11.50	51,300	39,500	55,500	8.50	35,000	1038083
	ADPF486016B*		55,500	40,000	13.00	11.50	51,300	39,500	55,500	8.50	35,000	1492583
	ADPF48601A*		55,500	40,000	13.00	11.50	51,300	39,500	55,500	8.50	35,000	872410
	ADPF48601B*		55,500	40,000	13.00	11.50	51,300	39,500	55,500	8.50	35,000	1069198
	AEPF426016A*		55,500	40,000	13.30	11.70	51,300	39,500	55,500	8.60	35,000	1038084
	AEPF426016B*		55,500	40,000	13.30	11.70	51,300	39,500	55,500	8.60	35,000	1277852
	AEPF426016C*		55,500	40,000	13.30	11.70	51,300	39,500	55,500	8.60	35,000	1492584
	AEPF42601A*		55,500	40,000	13.30	11.70	51,300	39,500	55,500	8.60	35,000	872425
	AEPF42601B*		55,500	40,000	13.30	11.70	51,300	39,500	55,500	8.60	35,000	1069199
	AEPT060-00*-1*		55,500	40,000	13.30	11.70	51,300	39,500	55,500	8.60	35,000	872437
	AR*F486016B*		55,500	40,000	13.00	11.50	51,300	39,500	55,500	8.50	35,000	1492585
	ARPF060-00B-1*		55,500	40,000	13.00	11.50	51,300	39,500	55,500	8.50	35,000	872430
	ARPF486016A*		55,500	40,000	13.00	11.50	51,300	39,500	55,500	8.50	35,000	1038080
	ARPF48601A*		55,500	40,000	13.00	11.50	51,300	39,500	55,500	8.50	35,000	872412
	ARPF48601B*		55,500	40,000	13.00	11.50	51,300	39,500	55,500	8.50	35,000	1069200
	ARPT061-00*-1*		55,500	40,000	13.00	11.50	51,300	39,500	55,500	8.50	35,000	872422
	ARUF061-00*-1*		55,500	40,000	13.00	11.50	51,300	39,500	55,500	8.50	35,000	872431
	ARUF486016A*		55,500	40,000	13.00	11.50	51,300	39,500	55,500	8.50	35,000	1038081
	ARUF48601A*		55,500	40,000	13.00	11.50	51,300	39,500	55,500	8.50	35,000	872434
	ARUF48601B*		55,500	40,000	13.00	11.50	51,300	39,500	55,500	8.50	35,000	1069201
	ASPF426016A*		55,500	40,000	13.30	11.70	51,300	39,500	55,500	8.60	35,000	1291683
	ASPF426016B*		55,500	40,000	13.30	11.70	51,300	39,500	55,500	8.60	35,000	1492586
	AT*F486016A*		55,500	40,000	13.00	11.50	51,300	39,500	55,500	8.50	35,000	1483539
	CA*F061*2*+EEP		55,500	40,000	13.00	11.50	51,300	39,500	55,500	8.50	35,000	869458
	CA*F4860*6A*+EEP		55,500	40,000	13.00	11.50	51,300	39,500	55,500	8.50	35,000	869469
	CA*F4860*6B*+EEP		55,500	40,000	13.00	11.50	51,300	39,500	55,500	8.50	35,000	1347213
	CHPF060D2*+EEP		55,500	40,000	13.00	11.50	51,300	39,500	55,500	8.50	35,000	869451
	CHPF4860D6A*+EEP		55,500	40,000	13.00	11.50	51,300	39,500	55,500	8.50	35,000	869431
	CHPF4860D6C*+EEP		55,500	40,000	13.00	11.50	51,300	39,500	55,500	8.50	35,000	1330422
	CSCF4860N6A*+EEP		55,500	40,000	13.00	11.50	51,300	39,500	55,500	8.50	35,000	869436
CSCF4860N6C*+EEP		55,500	40,000	13.00	11.50	51,300	39,500	55,500	8.50	35,000	1296640	
CT*F4860*6A*+EEP		55,500	40,000	13.00	11.50	51,300	39,500	55,500	8.50	35,000	1449976	
H61F+EEP		55,500	40,000	13.00	11.50	51,300	39,500	55,500	8.50	35,000	869463	

¹ Seasonal Energy Efficiency Ratio; Certified per ARI 210/240 @ 80°F/ 67°F/ 95°F

² Energy Efficiency Ratio @ 80°F/ 67°F/ 95°F

³ TVA Rating: BTU/h @ 75°F/ 63°F - 95°F

⁴ HSPF = Heating Seasonal Performance Factor

Notes:

- Always check the S&R plate for electrical data on the unit being installed.
- When matching the outdoor unit to the indoor unit, use the piston supplied with the outdoor unit or that specified on the piston kit chart supplied with the indoor unit.
- EEP - Order from Service Dept. Part No. B13707-38 or new Solid State Board B13707-35S. Part No. B13707-38 is not interchangeable with B13707-35S. The Goodman Gas Furnace contains the EEP cooling time delay

WIRING DIAGRAM — GSH13018-60A*/1B*

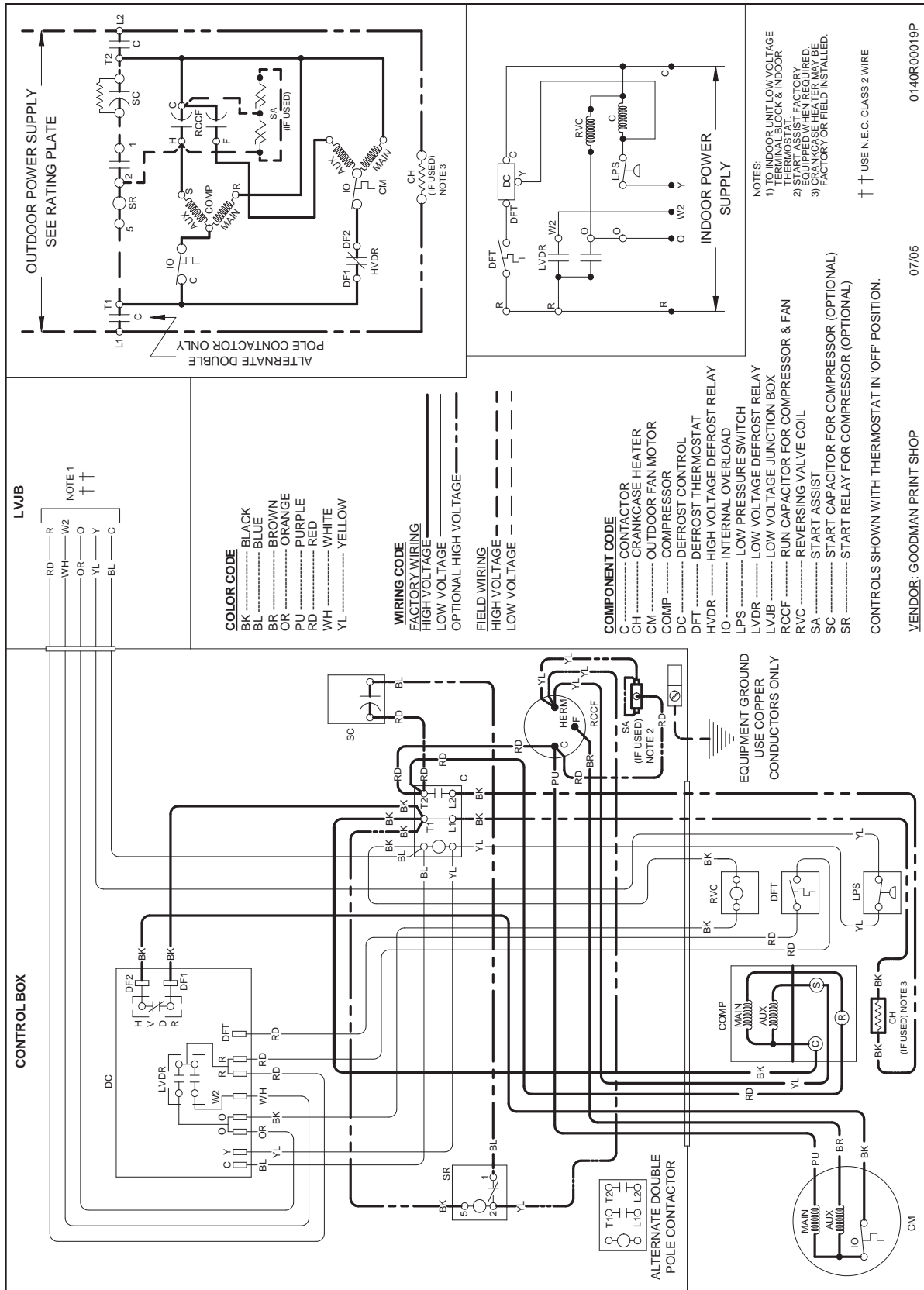

Wiring is subject to change. Always refer to the wiring diagram on the unit for the most up-to-date wiring schematic.

WIRING DIAGRAM — GSH13036-603A* & GSH13048-604A*

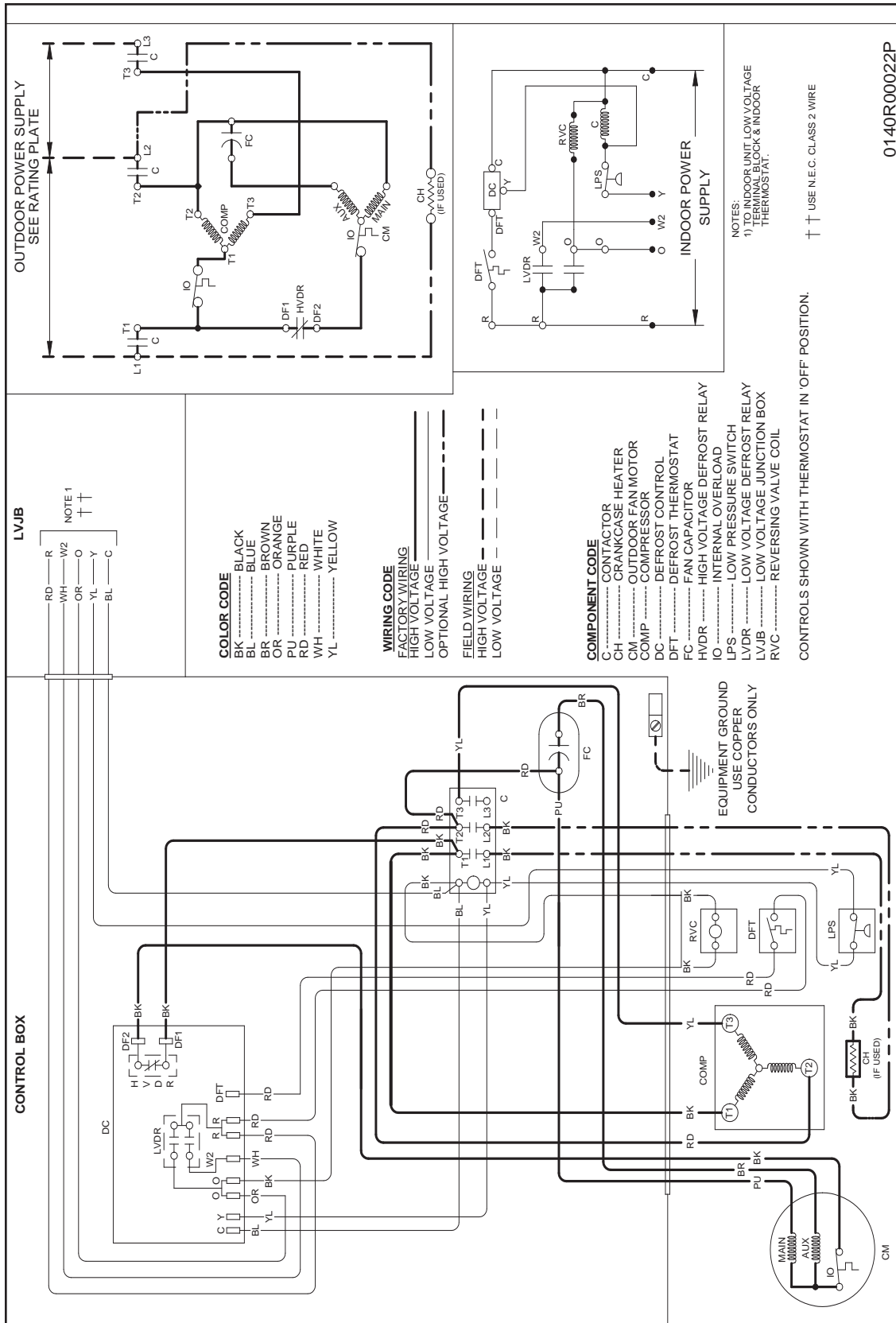

Wiring is subject to change. Always refer to the wiring diagram on the unit for the most up-to-date wiring schematic.

ACCESSORIES

Model	Description	GSH13 018	GSH13 024	GSH13 030	GSH13 036	GSH13 042	GSH13 048	GSH13 060
ABK-20	Anchor Bracket Kit ▼	X	X	X	X	X	X	X
AFE18-60A	All-fuel Kit	X	X	X	X	X	X	X
ASC01	Anti-Short Cycle Kit	X	X	X	X	X	X	X
CSR-U-1	Hard-start Kit	X	X	X	X			
CSR-U-2	Hard-start Kit				X	X	X	X
CSR-U-3	Hard-start Kit						X	X
FSK01A ¹	Freeze Protection Kit	X	X	X	X	X	X	X
OT/EHR18-60	Emergency Heat Relay kit	X	X	X	X	X	X	X
OT18-60A ²	Outdoor Thermostat with Lockout Stat	X	X	X	X	X	X	X
TX3N2 ³	TXV Kit -- Field-installed, non-bleed, expansion valve kit	X	X	X	X			
TX5N2 ³	TXV Kit -- Field-installed, non-bleed, expansion valve kit					X	X	X

▼ Contains 20 brackets; four brackets needed to anchor unit to pad

¹ Installed on indoor coil

² Required for heat pump applications where ambient temperatures fall below 0 °F with 50% or higher relative humidity.

³ Condensing units and heat pumps with reciprocating compressors require the use of start-assist components when used in conjunction with an indoor coil using a non-bleed thermal expansion valve refrigerant metering device.

