



AIRE ACONDICIONADO DE TECHO **MANUAL DEL PROPIETARIO**



-
-
-



-
-
-
-
-
-
-
-

Puede resultar en un incendio.

- No utilice un aparato de calefacción en el espacio acondicionado.
Una ventilación insuficiente puede causar accidentes debido a la deficiencia de oxígeno.
- El funcionamiento con las manos mojadas puede causar una descarga eléctrica.
- La exposición prolongada a corrientes de aire puede provocar molestias musculares y sequedad de ojos.
Esto podría afectar su condición física y causar problemas de salud.
- No toque la salida de aire o la persiana mientras la unidad esté en funcionamiento.
Puede causar lesiones.
- No introduzca nada en la entrada o salida de aire.
Esto puede causar lesiones, ya que el ventilador interno gira a alta velocidad.
- No coloque ningún objeto, especialmente cosas que contengan agua, como floreros, en la unidad.
Esto puede causar una descarga eléctrica.
- Guarde el control remoto fuera del alcance de los bebés y niños.
No realizar esto puede resultar en baterías tragadas por los niños u otros accidentes.
- Este electrodoméstico sólo está diseñado para su uso en el entorno doméstico.
El aparato de uso doméstico para las funciones domésticas típicas usadas en el ambiente del hogar que puede también ser utilizado por los usuarios no expertos, tales como tiendas, oficinas y otros ambientes de trabajo similares, como casas de la gran hoteles, moteles y otros tipos de ambientes residenciales.

1. READ BEFORE OPERATING

CAUTION

This symbol indicates the possibility of property damage or serious consequences.

- This product is intended for human comfort ONLY.
- Do not block air inlets or outlets. Poor performance, increased running costs and reduce product life will result.
- Do not control the system with main power switch.
It can cause fire or water leakage.
- Do not touch the fins on the heat exchanger.
Metal parts may have sharp edges that casue injury.
- Disconnect the unit when unused for long periods.
- Disconnect BEFORE cleaning or servicing.
- Never use strong detergents, solvents or abrasive polish on the product.
- Regular high level maintenance of the indoor and outdoor units is essential.
Specialist MAINTENANCE is required to do deep-clean, lubricate and function check of all critical components. Contact a qualified service personnel.

1.2 PART NAMES

INDOOR UNIT

- ① Louver
- ② Air inlet (with filter)
- ③ Installation part
- ④ Display
- ⑤ Remote controller*
- ⑥ Drain pipe

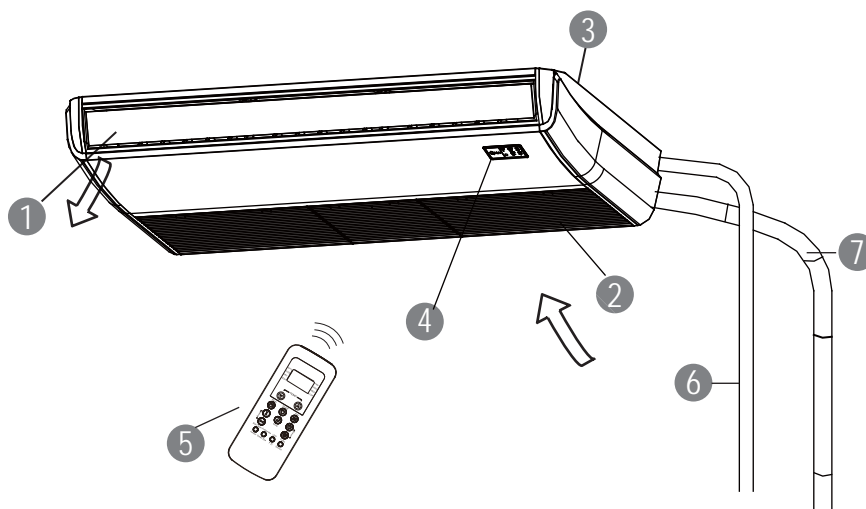

OUTDOOR UNIT

- ⑦ Connecting pipe
- ⑧ Air inlet
- ⑨ Air outlet

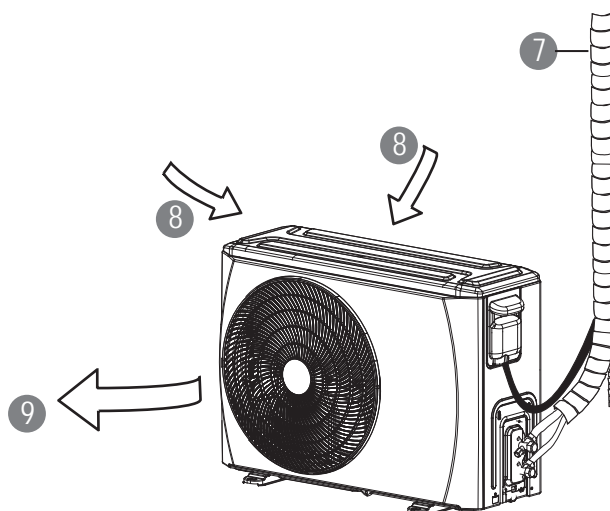

[*] Remote controller or wired controller: model dependent.

1. READ BEFORE OPERATING

DISPLAY

Function indicators on indoor unit display panel

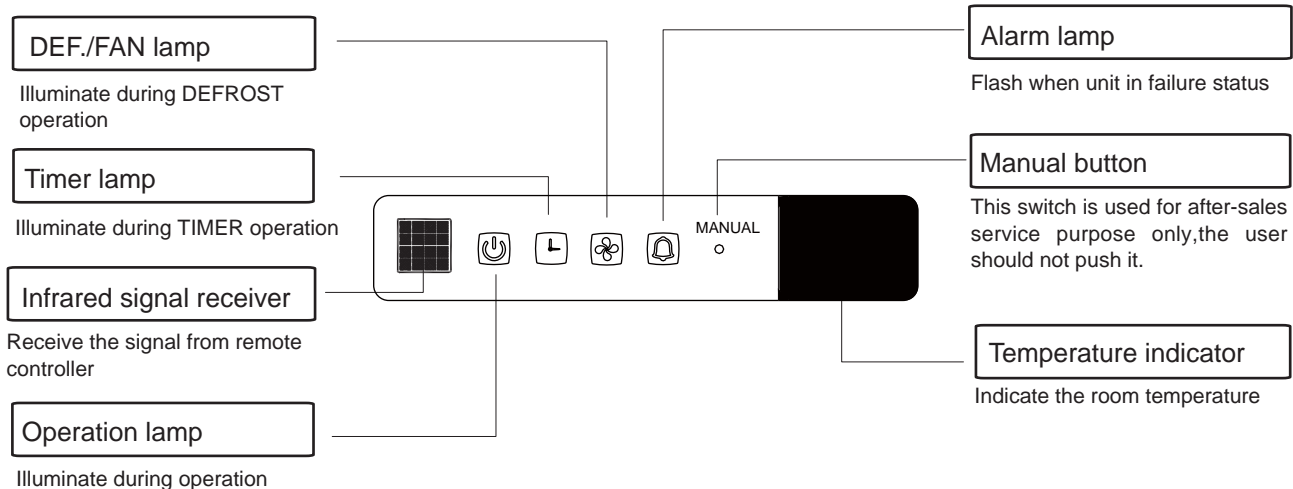

NOTE

- All the pictures in this manual are for explanation purpose only. They may be slightly different from the air conditioner you purchased (Model dependent). The actual shape shall prevail.
- A guide on using the remote controller (or wired controller) is included in this literature packaged.

2. OPEATION

2.1 OPEATING CONDITIONS

Opeating Conditions		Indoor	Outdoor
Cooling Operation	Upper limit	32°C DB	46°C DB
	Lower limit	18°C DB	-10°C DB
Heating Operation	Upper limit	27°C DB	24°C DB
	Lower limit	0°C DB	-15°C DB

Note: DB - Dry Bulb

- Optimum performance will be achieved within these operating temperatures.
- When the unit operates above or below these conditions for a long time, system diagnostics may detect a malfunction and the unit will not operate properly.
- Room relative humidity - less than 80%. If the air conditioner operates outside this range, the surface of the air conditioner may attract condensation.

2. OPEATION

2.2 HOW IT WORKS

Basic Operation Modes: AUTO / COOL / DRY / HEAT / FAN

AUTO Mode

- In this setting the system will automatically change modes and fan speed to the set temperature.
- [In spring and autumn, closer temperature control may require COOL/HEAT mode changes.]

DRY Mode

In this mode, priority is given to dehumidifying the air. Low fan speed and compressor cycling is used to achieve this and regulate room temperature.

Auto Defrost

Ice develops on the outdoor unit in heating mode. To defrost this ice, the indoor fan stops for a few minutes before heating continues.

Compressor Delay

At start-up, a time delay of 3 to 4 minutes protects the compressor.

Cold Draft Prevention

To avoid uncomfortable drafts in heating mode, the indoor unit is preheated before the fan starts. This delay should only last a few minutes.

Auto Restart*

The unit will automatically restart after a power interruption. Previous user settings are all recovered.

Auto Leak Detection*

When refrigerant leakage is detected, the unit will display "EC" code or flash LEDs.

Louver Memory*

Louver angle is memorised and will return to the position last selected by the user.

Adjusting Air Flow Direction

- Press "AIR DIRECTION" on remote controller to adjust air flow direction. The louver position moves slightly each time the button is pressed. Adjust the louver upwards in cooling mode while downwards in heating mode to achieve best comfort.
- Press "SWING" to engage continous louver motion. Horizontal and Vertical louver can be set respectively.

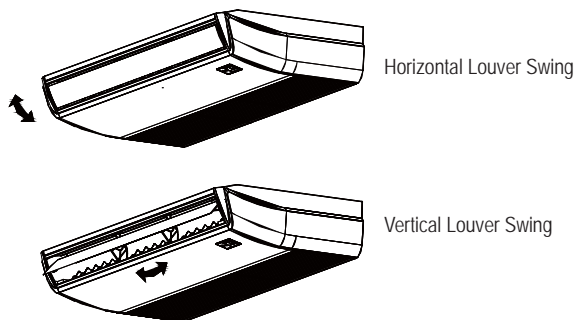

NOTE

- Please refer to the REMOTE CONTROLLER MANUAL for details.
- In cooling or dry mode, condensate may form and drip from unit in high humidity condition if louver position is in Maximum down.
- Do not operater the unit with louver closed or narrow opening. Restricted air flow reduced performance and may cause condensate.

[*] Model dependent

CAUTION

Do not attempt to adjust the louver by hand.

2.3 HINTS FOR ECONOMICAL OPERATION

- Adjust the temperature to achieve moderate comfort levels. Excessively low or high temperatures waste energy.
- Improve performance by keeping windows and doors closed.
- Limit energy usage [run time] by using the TIMER function.
- Do not block air inlets or outlets. Poor performance, increased running costs and reduced product life will result.
- Inspect the air filters periodically, and clean them when needed.
- Disconnect the power source if unit will not be used for a long period.

3. CARE AND MAINTENANCE

⚠ CAUTION

- DISCONNECT from power source BEFORE attempting to clean or service!
- Use a soft damp cloth when cleaning the grille, casing and remote control.
- Always contact a qualified service personnel to carry out repair or any non-user serviceable maintenance, such as deep-cleaning, lubricate and function check of critical component.

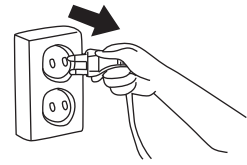

■ General Cleaning

Use a soft damp cloth when cleaning the grille, casing and remote controller.

- No chemicals e.g. detergents, solvents, abrasive polish, etc.
- No heat (over 40 °C)

■ Cleaning the air filter

To maintain the good performance, regularly inspect air filters and clean them if required.

- Remove the screws to open the grille.
- Take out the filter.

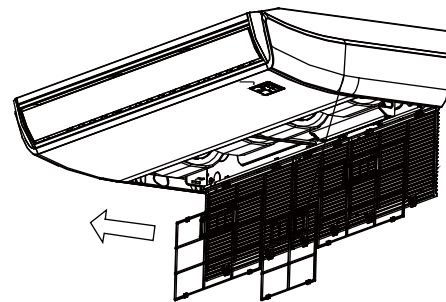
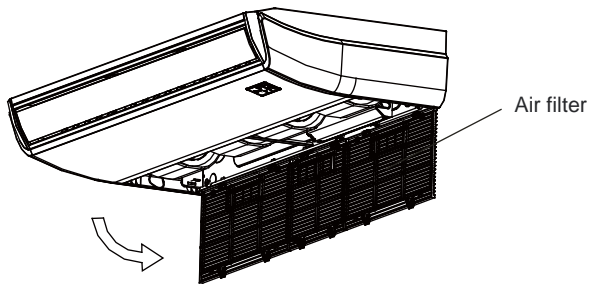

- Clean the air filter

Vacuum cleaner or pure water may be used to clean the air filter. If the dust accumulation is too heavy, please use soft brush and mild detergent to clean it and dry out in cool place. Re-install the air filter and air inlet grille in reverse order described above.

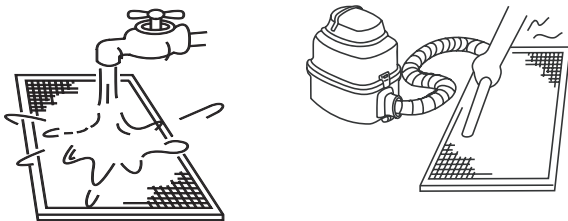

NOTE:

The air-in side should face up when using vacuum cleaner.
The air-in side should face down when using water.

■ Storage Preparation [long idle periods]

1. Clean the air filters
2. In humid or damp climates, operate in Fan only mode until the unit has dried out.
3. Turn the air conditioner off with the remote and remove the batteries.
4. Disconnect from the power source.

■ Re-use After Storage

1. Check if anything block the air inlet and outlet.
2. Clean the air filters
3. Check the wires if any damaged or proper grounded.
4. Reconnect to the power source
5. Wait 24 hours when the ambient temperature is low.
6. Reinstall the batteries into the remote controller and turn the unit on.

4. TROUBLE SHOOTING

- Please carry out the following check before making a service call.

CONCERN	PLEASE FIRST CHECK!
Unit does not work at all	• Is there a power failure?
	• Has a switch been turned off, a circuit breaker tripped or a fuse blown?
	• Are the batteries in the remoter control fresh?
	• Are the clock and timer on the remote set correctly?
Poor cooling or heating	• Are the temperature and mode settings correct?
	• Are the air filters clean?
	• Are the windows and doors closed?
	• Is air flow unrestricted in & out of indoor & outdoor units?
	• Is fan speed on high and louvers allowing maximum flow?

- **Guides, Tips and Casutions**

The following may occur during normal operation, and may not indicate malfunction.

Case	Explanation
Cooling or heating is delayed.	A 3 minute delay protects the compressor.
Fan speed changes – off , very slow and then normal	Automatically happens in heating mode - prevents cold air blowing onto occupants.
The heating operation stops suddenly and defrost-light blinks.	Frost removal on outdoor unit is in progress (5 – 10mins).
Mist coming out of the indoor unit	May occur when unit temperature is low and room air is hot and humid.
Low volume sounds are emitted by the air conditioner	"Hissing": normal – gas pressure equalizing when compressor stops or starts.
	"Squeaking": normal expansion and contraction of plastic and metal parts.
	Rushing air – normal when louver resets its position.
Dust discharges from the unit.	May occur when air conditioner is used for the first time or has not been used for a long time.
Emits a peculiar odour.	Usually caused by chemicals, cigarette smoke, cooking etc. If not the case call your suitable contractor.
Changes to fan only while cooling or heating.	Room temperature is the same as that selected with the remote. If not the case call a suitable contractor.
Poor heating performance	May occur when outdoor temperatures are close to or below zero degrees Celsius.
Turns on automatically	Normal when power is restored after a power failure.
Operation is erratic, unpredictable or unresponsive.	Interference from cell phone towers and remote boosters may cause the unit to malfunction.
	Disconnect the power and then re-connect.
	Press the ON/OFF button on the remote controller to restart operation.
	If the problem is not resolved call a suitable contractor.

4. TROUBLE SHOOTING

■ Contact your dealer

In the case of ANY of the following, turn off the unit immediately!

- Power cord is damaged or abnormally warm.
- Burning odours are smelled.
- Loud or abnormal sounds are heard.
- A power fuse blows or a circuit breaker trips frequently.
- Water or other objects fall into or out of the unit.
- Indicators blink continuously.
- A self-diagnostic code is displayed e.g. E0, E1, E2 ... or P0, P1, P2... etc.

- Record the product's model number,
- Contact a suitable contractor,
- Share all observed details!

CAUTION

DO NOT ATTEMPT TO CORRECT THESE ITEMS YOURSELF!
CONTACT A QUALIFIED SERVICE PERSONNEL!



Carrier is committed for continuous improvement of Carrier products according to national and international standards to ensure the highest quality and reliability standards, and to meet market regulations and requirements. All specifications subject to change without prior notice according to Carrier policy of continuous development

20160824

