

SAMSUNG

SYSTEM AIR CONDITIONER

DVM CHILLER

AG010KSVAFH/AG015KSVAFH

AG010KSVAJH/AG015KSVAJH

SERVICE *Manual*

DVM CHILLER



CONTENTS

1. Precautions
2. Product Features and Specifications
3. Disassembly and Reassembly
4. Troubleshooting
5. PCB Diagram and Parts List
6. Wiring Diagram
7. Cycle Diagram
8. Key Options
9. Trial Operation
10. Reference sheet

DVM CHILLER derived model status

Application division	Derived models	
F Power model	AG010KSVAFH/AA	AG015KSVAFH/AA
J Power model	AG010KSVAJH/AA	AG015KSVAJH/AA



Contents

1. Precautions.....	1
1-1 Precautions for the Service	1
1-2 Precautions for the Static Electricity and PL.....	1
1-3 Precautions for the Safety.....	1
1-4. Precautions for Handling Refrigerant of the DVM CHILLER.....	2
1-5. Precautions for Welding the DVM CHILLER Pipe.....	2
2. Product Features and Specifications.....	3
2-1. Product Features	3
2-1-1. Major Advantages of Product.....	3
2-1-2. Changes in comparison to DVM S.....	6
2-1-3. Structure of product (H/P)	8
2-2. Product Specifications.....	9
2-2-1. Specifications	9
3. Disassembly and Reassembly.....	11
3-1. Necessary Tools.....	11
3-2. Disassembly and Reassembly	12
3-2-1. AG010/015KSV***	12
3-2. Service work of main parts.....	16
3-3-1. Temperature sensor & Pressure sensor in the water pipe side	16
3-3-2. Plate type heat exchanger PHE.....	18
4. Troubleshooting.....	27
4-1. Check-up Window Description	27
4-2. Service Operation	28
4-2-1. Special operation	28
4-2-2. DVM Chiller EEPROM code table by models.....	31
4-2-3. Option code by model classification	31
4-2-4. Number Display Method	32
4-3. Appropriate measures for symptoms.....	36
4-3-1. Reversed phase / No phase check (Outdoor unit with 3 phase power)	36
4-3-2. Main PCB has no power phenomenon	38
4-3-3. Communication error between hydro and outdoor unit during tracking	39
4-3-4. Communication error between indoor and outdoor unit after tracking	41
4-3-5. Internal communication error of the outdoor unit C-Box.....	42
4-3-6. Internal PCB communication error of the outdoor unit C-Box	43
4-3-7. Outdoor temperature sensor error.....	45
4-3-8. COND OUT temperature sensor error (Open / Short).....	46
4-3-9. Outdoor unit COND OUT sensor breakaway error.....	47
4-3-10. Compressor discharge or TOP 1/2 temperature sensor error.....	48
4-3-11. Compressor discharge or TOP temperature sensor breakaway error.....	49
4-3-12. E269 : Suction temperature sensor breakaway error	50
4-3-13. High pressure sensor error (Open / Short)	51
4-3-14. Low pressure sensor error (Open / Short).....	52
4-3-15. Suction temperature sensor error (Open / Short)	53
4-3-16. Liquid pipe temperature sensor error (Open / Short)	54
4-3-17. EVI IN temperature sensor error (Open / Short)	55
4-3-18. EVI OUT temperature sensor error (Open / Short)	56
4-3-19. Suction-2 temperature sensor error (Open / Short).....	57
4-3-20. Measures of other outdoor unit error	58
4-3-21. E407 : COMP DOWN due to high pressure protection control.....	59
4-3-22. E410 : COMP DOWN due to low pressure protection control	60
4-3-23. E416: Suspension of starting due to compressor discharge temperature sensor / TOP temperature sensor ..	61
4-3-24. 3-phase Input Wiring error	62
4-3-25. E428: : Suspension of starting by abnormal compression ratio.....	63
4-3-26. EVI EEV opening error	64

Contents

4-3-27. Refrigerant leakage error.....	65
4-3-28. Prevention of heating operation due to outdoor temperature.....	66
4-3-29. Fan starting error.....	67
4-3-30. Fan lock error.....	69
4-3-31. Momentary blackout error.....	70
4-3-32. Outdoor Fan Motor overheating.....	71
4-3-33. Fan IPM Overheat error.....	72
4-3-34. Compressor starting error.....	73
4-3-35. Inverter Overcurrent error.....	75
4-3-36. Overvoltage / Low voltage error.....	78
4-3-37. DC Link voltage sensor error.....	79
4-3-38. Fan Motor Overcurrent error.....	80
4-3-39. Input / Output Current sensor error.....	82
4-3-40. Outdoor Fan PCB Overvoltage / Low voltage error.....	83
4-3-41. Hall IC (Fan) error.....	84
4-3-42. Inverter overheat error.....	85
4-3-43. Option setting error of outdoor unit.....	86
4-3-44. Hydro inlet temperature sensor (Tw1) Short/Open.....	87
4-3-45. Hydro outlet temperature sensor (Tw2) Short/Open.....	88
4-3-46. Frozen damage error.....	89
4-3-47. Error when freeze prevention Comp Off.....	90
4-3-48. Hydro outlet temperature sensor Breakaway.....	91
4-3-49. Water flow error(Water pressure sensor or Flow switch).....	92
4-3-50. Error on pump magnetic switch malfunction.....	93
5. PCB Diagram and Parts List.....	94
5-1. ASSY PCB MAIN-HYDRO.....	94
5-2. ASSY PCB MAIN.....	98
5-3. ASSY PCB SUB-FAN.....	100
5-4. ASSY PCB SUB-EMI (F power model only).....	102
5-5. ASSY PCB SUB-EMI (J power model only).....	103
5-6. ASSY PCB MAIN-HUB.....	105
5-7. ASSY PCB INVERTER (F power model only).....	109
5-8. ASSY PCB SUB-COMM.....	113
6. Wiring Diagram.....	114
6-1. DVM CHILLER hydro part wiring diagram(Model : AG010/015KSVA*** Series).....	114
6-2. DVM CHILLER inverter control part wiring diagram(Model : AG010/015KSVAF** Series).....	116
6-3. DVM CHILLER inverter control part wiring diagram(Model : AG010/015KSVAJ** Series).....	118
7. Cycle Diagram.....	120
8. Key options.....	122
8-1. Setting hydro controller option.....	122
8-2. How to set hydro controller option.....	124
8-3. Setting inverter controller option.....	129
9. Trial operation.....	134
9-1. Trial operation for each CHILLER unit.....	134
10. Reference Sheet.....	136
10-1. index of Model Name.....	136

1. Precautions

1-1 Precautions for the Service

- **Use the correct parts when changing the electric parts.**
 - Please check the labels and notices for the model name, proper voltage, and proper current for the electric parts.
- **Fully repair the connection for the types of harness when repairing the product after breakdown.**
 - A faulty connection can cause irregular noise and problems.
- **Completely remove dust or foreign substances on the housing, connection, and inspection parts when performing repairs.**
 - This can prevent fire hazards for tracking, short, etc.
- **Check whether the parts are properly and securely assembled after performing repairs.**
 - These parts should be in the same condition as before the repair.

1-2 Precautions for the Static Electricity and PL

- **Please carefully handle the PCB power terminal during repair and measurement when it is turned on since it is vulnerable to static electricity.**
 - Please wear insulation gloves before performing PCB repair and measurement.
- **Check if the place of installation is at least 2m(6.6ft) away from electronic appliances such as TV, video players, and stereos.**
 - This can cause irregular noise or degrade the picture quality.
- **Please make sure the customer does not directly repair the product.**
 - Arbitrary dismantling may result in electric shock or fire.

1-3 Precautions for the Safety

- **Do not pull or touch the power plug or the subsidiary power switch with wet hands.**
 - This may result in electric shock or fire.
- **Do not bend the wire too much or position it so that it can be damaged by a heavy object on top.**
 - This may result in electric shock or fire.
- **Ground the connection if it is necessary.**
 - The connection must be grounded if there is any risk of electrical short due to water or moisture.
- **Fix the product securely to resist natural phenomenon such as earthquake.**
 - If the product is not properly fixed, it may fall down and cause an accident.
 - When installing the unit in a small area, take measure to keep the refrigerant concentration from exceeding allowable safety limits in case of refrigerant leakage. Consult the dealer for precautionary measure before the installation.
 - When refrigerant leaks and exceed dangerous concentration level, it may cause suffocation accidents.

1-4. Precautions for Handling Refrigerant of the DVM CHILLER

Environmental Cautions: Air pollution due to gas release

- **Safety Cautions**

If liquid gas is released, then body parts that come into contact with it may experience frostbite/blister/numbness.

If a large amount of gas is released, then suffocation may occur due to lack of oxygen. If the released gas is heated, then noxious gas may be produced by combustion.

- **Container Handling Cautions**

Do not subject container to physical shock or overheating. (Flowage is possible while moving within the regulated pressure.)

1-5. Precautions for Welding work the DVM CHILLER Pipe

- **Dangerous or flammable objects around the pipe must be removed before the welding.**

- **If the refrigerant is kept inside the product or the pipe, then remove the refrigerant prior to welding.**

If the welding is carried out while the refrigerant is kept inside, the welding cannot be properly performed. This will also produce noxious gas that is a health hazard. This leakage will also explode with the refrigerant and oil due to an increase in the refrigerant pressure, posing a danger to workers.

- **Please remove the oxide produced inside the pipe during the welding with nitrogen gas.**

Using another gas may cause harm to the product or others.

**Climaproyectos**
.com

2. Product Features and Specifications

2-1 Product Features

2-1-1 Major Advantages of Product

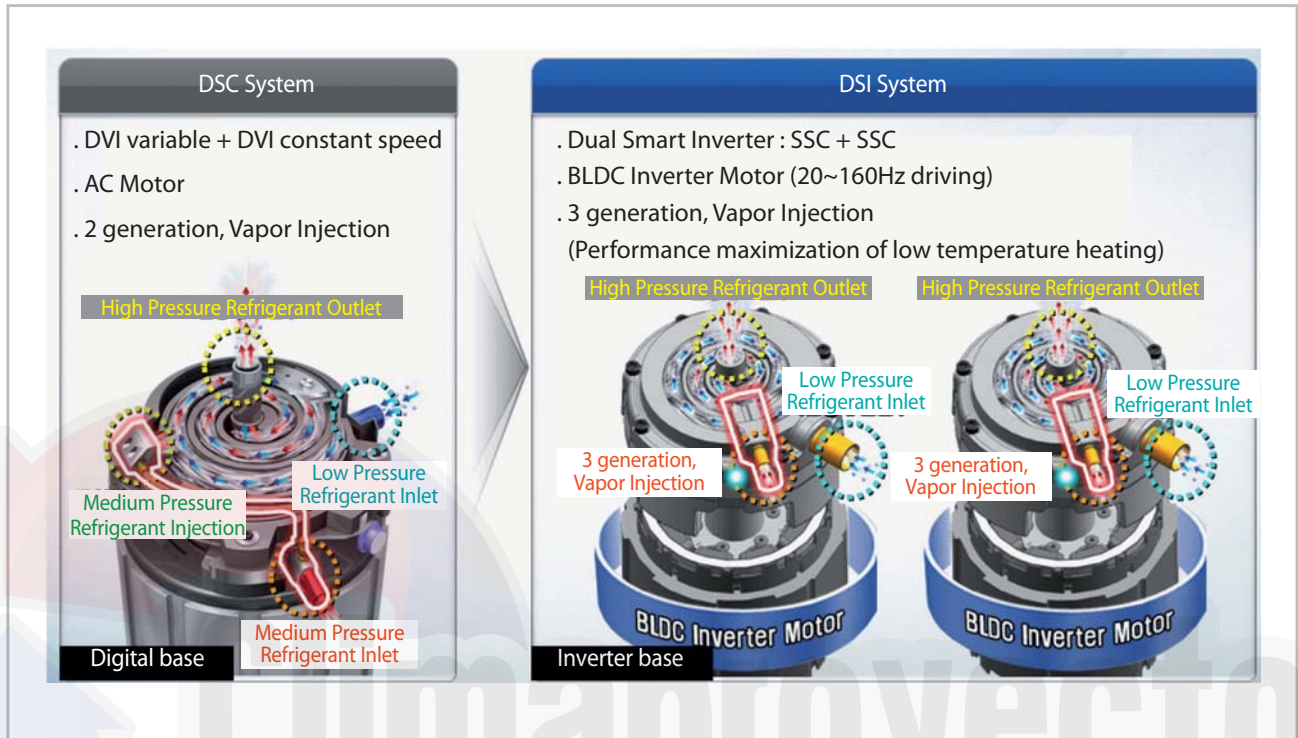

■ Control Logic

1) Simultaneous operation control

Individual capacity control based on Water Out Sensor equipped inside each Unit
Running the capacity control runs all the Units inside the module to control the capacity.

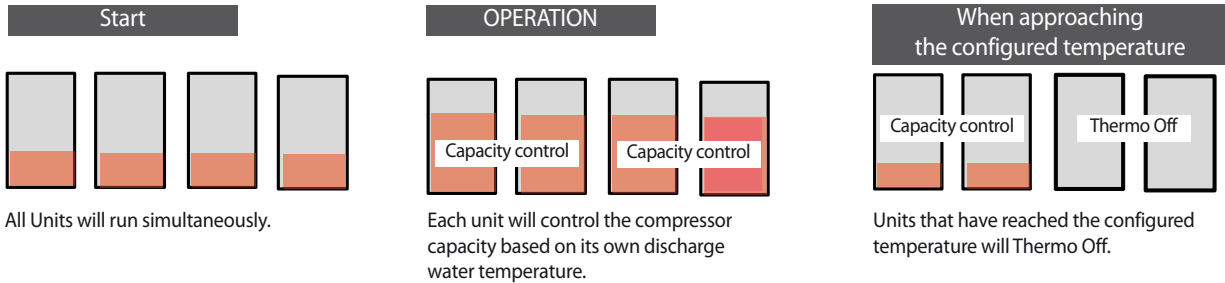

2) Rotation Logic

Uses the average value of the Water Out Sensor of the Unit whose pump inside the module is in operation.
Running the capacity control will run 1 Unit first. Later, when the relevant Unit is run to maximum capacity, the next Unit in order of priority will run.

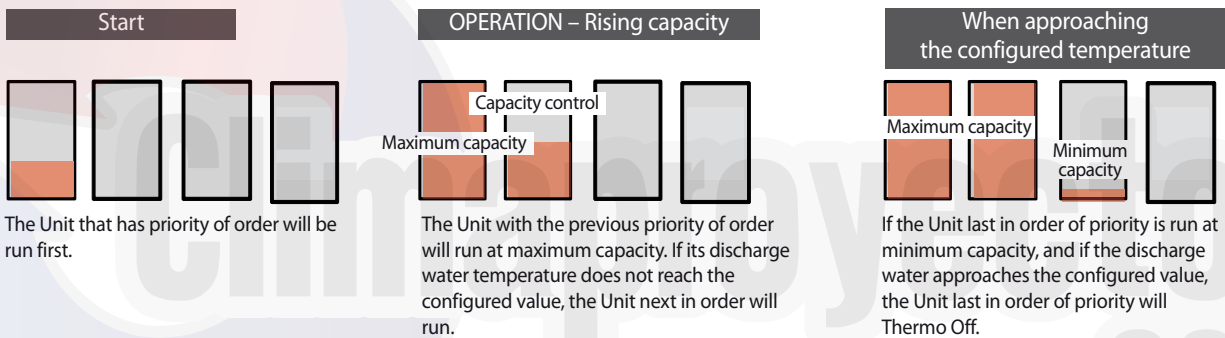

3) Efficiency priority control

Control-based Water Out Temp: Uses the average value of the Water Out Sensor of the Unit whose pump inside the module is in operation. Precision control while in low load state / Load response speed prioritized when load capacity is increased

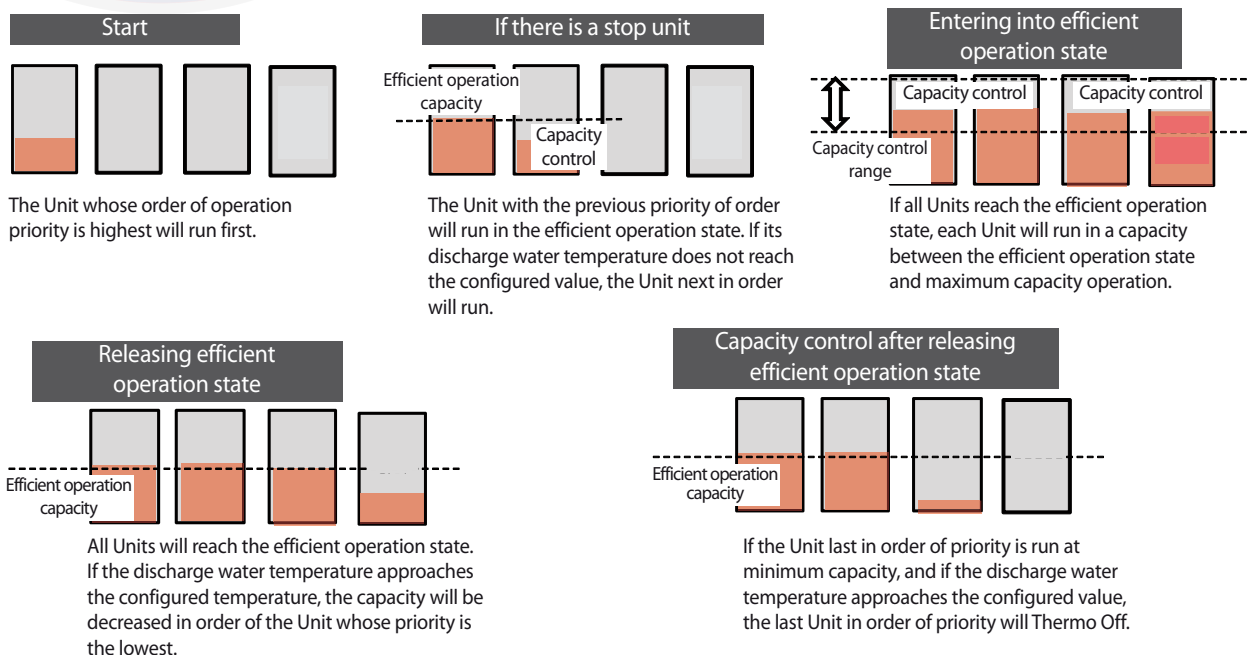

Feature (cont.)

■ Inverter circuit refrigerant cooling technology

- ▶ Applied high efficiency refrigerant cooling circuit. Secured stable Inverter PCB cooling performance.
- Air cooling method : When natural convection / electric heat performance is low and is high load, efficiency is fallen.
- Refrigerant cooling system : Forced circulation / electric heat performance is high and control of (thermal conductivity is 10 times higher than air) load is available.

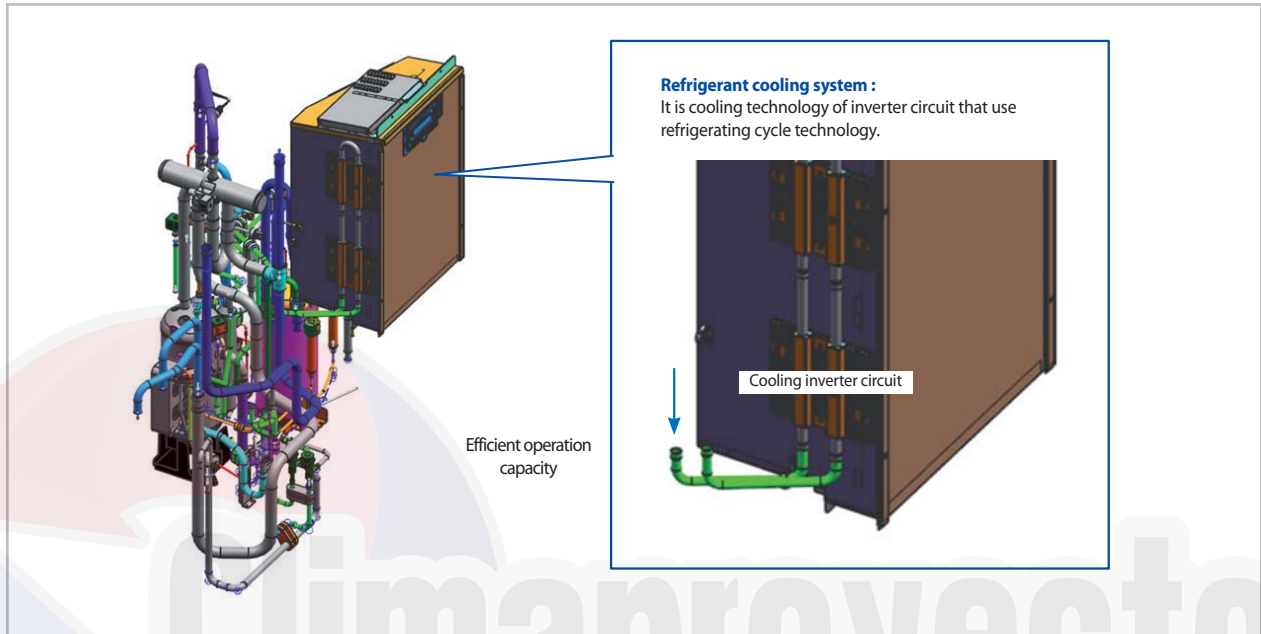





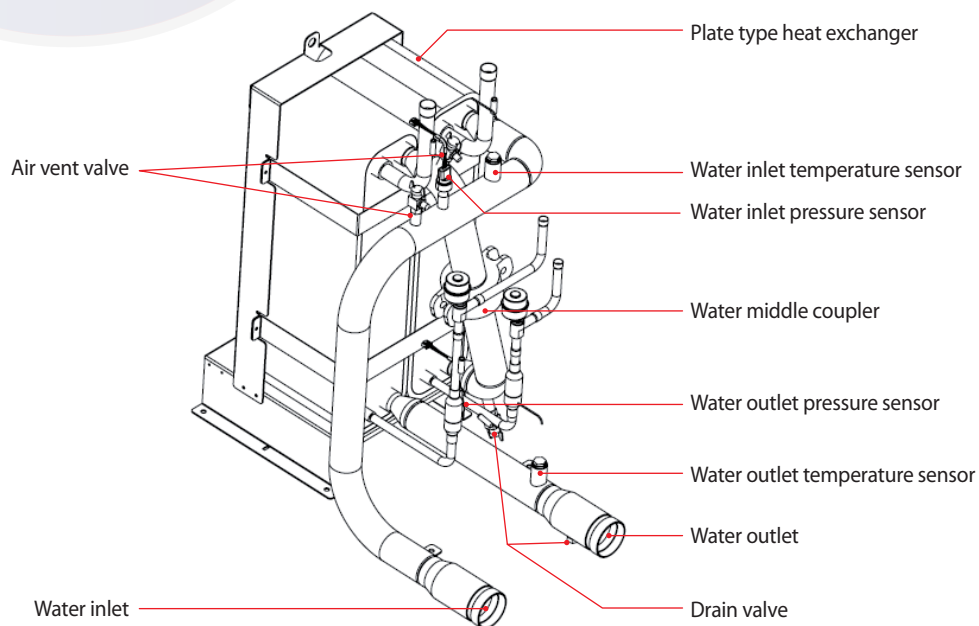







■ Obtained cooling and heating performance by high effectiveness applying plate type heat exchanger

- Manufacture hot/cool water using plate type heat exchanger
- Freeze protection control specification(application for shrinkage temperature/pressure)
- Air purge, Drain valve.

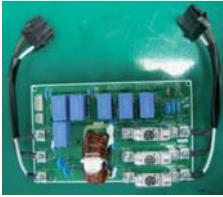

2-1-2. Changes in comparison to DVM S

Changed part		Changed item and feature	Basic	Revision
Hydro		<ul style="list-style-type: none"> - Producing hot water & cold water by using plate type heat exchanger. - Control specification for freeze prevention(the application of the water temperature/the pressure sensor). - Air purge, Drain valve, Inlet/Outlet Cut grooved pipe. 	-	
Control Box (Hydro)	Hydro PCB	New Hydro PCB. <ul style="list-style-type: none"> - Hot&Cold water load and protection control load of Freeze protection. - Module controller, External control contact, Supply of Load/Sensor. 	-	
Control Box (Inverter)	Main PCB	Change Main PCB. <ul style="list-style-type: none"> - Separation of Load/Control - Deleting of option resistance by model.(standardization) - Need of option download at the time of the PCB replacement. 		
	Hub PCB	New Hub PCB. <ul style="list-style-type: none"> - Separation of Load/Control. - Improvement of the fixed form of Load/Sensor wire. 		
	FAN PCB	FAN Controller using 3-phase power. <ul style="list-style-type: none"> - Prevention of phase imbalance. - Protection of IPM temperature. 		
	EMI PCB	J POWER MODEL - AG010KSVAJH/AA AG015KSVAJH/AA		
F POWER MODEL - AG010KSVAFH/AA AG015KSVAFH/AA				

Changes in comparison to DVM S (cont.)

Changed part		Changed item and feature	Basic	Revision
Control Box (Inverter)	InverterPCB (Compressor control PCB)	J POWER MODEL - AG010KSVAJH/AA AG015KSVAJH/AA		←
		F POWER MODEL - AG010KSVAFH/AA AG015KSVAFH/AA		←
	Communication terminal block	Communication terminal block mounted on the PCB.		←
REACTOR		Small capacity. - PF No. 8		←
		Large capacity. - PF No. 9		←
Compressor		- F power resource : 66cc - J power resource : 70cc - High-capacity compressor application.		←

2-1-3. Structure of product (H/P)

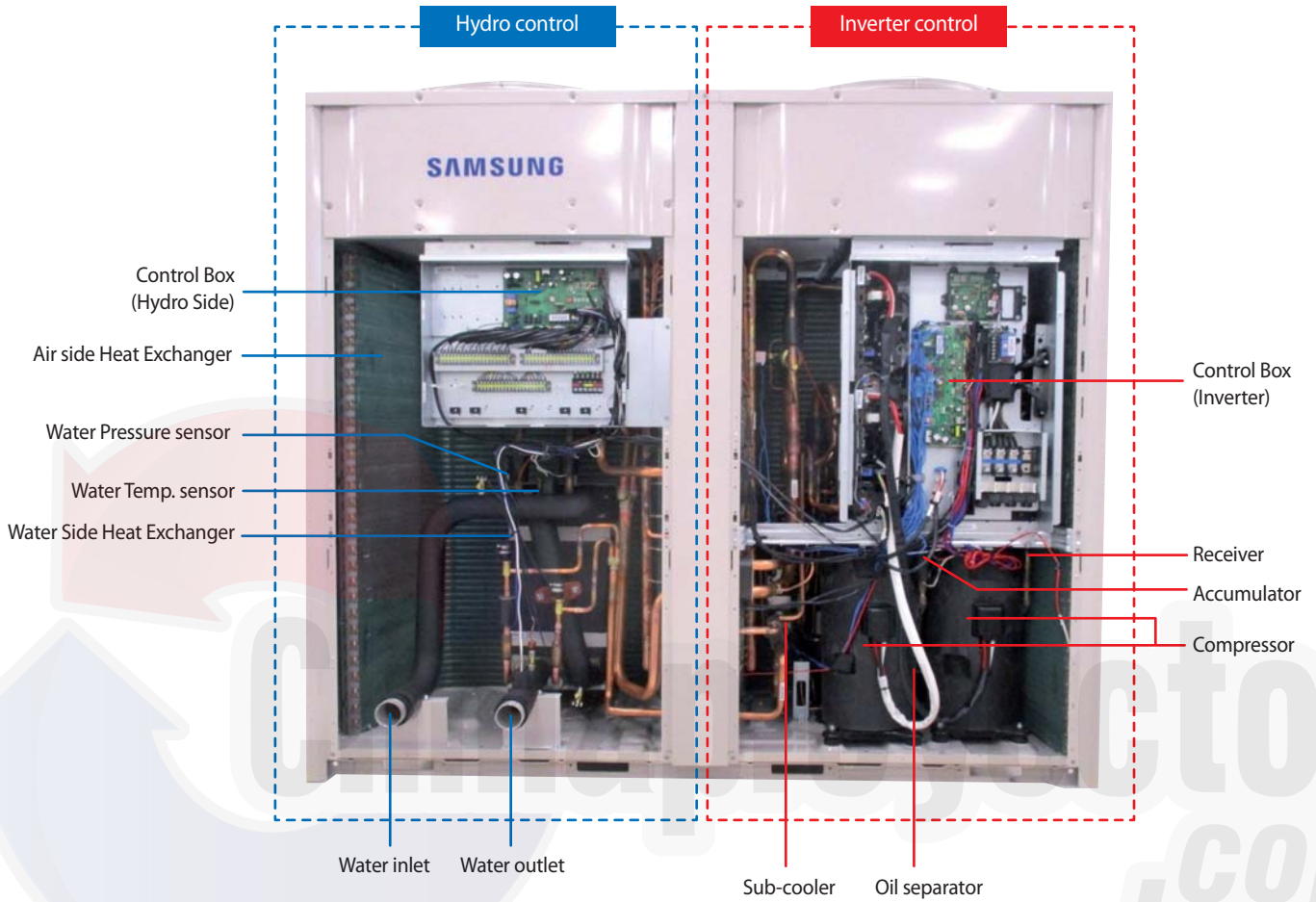

2-2. Product Specifications

2-2-1. Specifications

Model Name			AG010KSVAFH/AA	AG015KSVAFH/AA	AG010KSVAJH/AA	AG015KSVAJH/AA		
Power Supply		Φ, #, V, Hz	3,3,208~230,60	3,3,208~230,60	3,3,460,60	3,3,460,60		
Capacity (Rated)	Ton(Nominal)		usRT	10	15	10	15	
	Cooling	(Ambient 95°F Entering/Leaving Temp 55/44°F)		kW	35.2	50.1	35.2	50.1
				kBtu/h	120.0	171.0	120.0	171.0
	Heating	Dry/Wet Bulb 44/43°F	Leaving Temp. 105°F	kW	37.5	53.3	37.5	53.3
				kBtu/h	128.0	182.0	128.0	182.0
			Leaving Temp. 120°F	kW	35.2	50.1	35.2	50.1
				kBtu/h	120.0	171.0	120.0	171.0
		Dry/Wet Bulb 17/15°F	Leaving Temp. 105°F	kW	24.6	26.4	24.6	26.4
				kBtu/h	84.0	90.0	84.0	90.0
			Leaving Temp. 120°F	kW	23.4	24.9	23.4	24.9
			kBtu/h	80.0	85.0	80.0	85.0	
Power	Power Input	Cooling		kW	10.71	17.10	10.71	17.10
		Heating Dry/Wet Bulb 44/43°F	Leaving Temp. 105°F		9.77	15.17	9.77	15.17
			Leaving Temp. 120°F		11.54	17.45	11.54	17.45
		Heating Dry/Wet Bulb 17/15°F	Leaving Temp. 105°F		11.20	12.00	11.20	12.00
			Leaving Temp. 120°F		12.70	13.08	12.70	13.08
		Cooling				29.59	47.24	15.81
	Current Input	Heating Dry/Wet Bulb 44/43°F	Leaving Temp. 105°F	A	26.99	41.91	14.43	22.40
			Leaving Temp. 120°F		31.88	48.20	17.04	25.77
		Heating Dry/Wet Bulb 17/15°F	Leaving Temp. 105°F		30.94	33.15	16.54	17.72
			Leaving Temp. 120°F		35.08	36.13	18.75	19.31
	MCA		A	52.00	70.00	24.00	40.00	
	MOP		A	70.00	90.00	30.00	50.00	
	COP	Normal Cooling		W/W	3.28	2.93	3.28	2.93
				(Btu/h)/W	11.20	10.00	11.20	10.00
Normal Heating Dry/Wet Bulb 44/43°F		Leaving Temp. 105°F	W/W	3.84	3.52	3.84	3.52	
			(Btu/h)/W	13.10	12.00	13.10	12.00	
		Leaving Temp. 120°F	W/W	3.05	2.87	3.05	2.87	
			(Btu/h)/W	10.40	9.80	10.40	9.80	
Normal Heating Dry/Wet Bulb 17/15°F		Leaving Temp. 10°F	W/W	2.20	2.20	2.20	2.20	
			(Btu/h)/W	7.50	7.50	7.50	7.50	
		Leaving Temp. 120°F	W/W	1.85	1.90	1.85	1.90	
			(Btu/h)/W	6.30	6.50	6.30	6.50	
Efficiency	IPLV		(Btu/h)/W	20.5	18.8	20.5	18.8	
Compressor	Type		-	Scroll Inverter	Scroll Inverter	Scroll Inverter	Scroll Inverter	
	Output		kW x n	6.45x2	6.45x2	6.76x2	6.76x2	
	Model Name		-	DS4GJ5066EVA	DS4GJ5066EVA	DS-GB070FAVA	DS-GB070FAVA	
	Oil	Type	-	PVE	PVE	PVE	PVE	
Fan	Type		-	Propeller	Propeller	Propeller	Propeller	
	Output x n		W	630 x 2	630 x 2	630 x 2	630 x 2	
	Air Flow Rate		CMM (CFM)	364 (12,855)	364 (12,855)	364 (12,855)	364 (12,855)	
	External Static Pressure	Max.	mmAq (inAq)	8.0 (0.315)	8.0 (0.315)	8.0 (0.315)	8.0 (0.315)	
			Pa	78.5	78.5	78.5	78.5	

Model Name		AG010KSVAFH/AA	AG015KSVAFH/AA	AG010KSVAJH/AA	AG015KSVAJH/AA	
Water Side Heat Exchanger	Type	-	Brazing Plate	Brazing Plate	Brazing Plate	Brazing Plate
	Water Flow (Cooling/Heating)	LPM (CFM)	90.9 (3.21)	129.5 (4.57)	90.9 (3.21)	129.5 (4.57)
	Pressure Drop	kPa (psi)	37 (5.37)	70 (10.15)	37 (5.37)	70 (10.15)
	Max Operationg Pressure	MPa (psi)	1.0 (145)	1.0 (145)	1.0 (145)	1.0 (145)
	Connection Type	-	50A Cut Groove	50A Cut Groove	50A Cut Groove	50A Cut Groove
	Pipe (Inlet/Outlet)	A	50	50	50	50
	Quantity	EA	2	2	2	2
Minimum water quantity	Minimum water quantity	L	272.5	388.4	272.5	388.4
		gal	72.0	102.6	72.0	102.6
Refrigerant	Type	-	R410A	R410A	R410A	R410A
	Factory Charging	lbs	40	40	40	40
Sound	Sound Pressure	dB(A)	60	62	60	62
External Dimension	Net Weight	kg	435	435	435	435
		lbs	959	959	959	959
	Shipping Weight	kg	457	457	457	457
		lbs	1,008	1,008	1,008	1,008
	Net Dimensions (WxHxD)	mm (inch)	1,795x1,695x765 (70.67x66.73x30.12)	1,795x1,695x765 (70.67x66.73x30.12)	1,795x1,695x765 (70.67x66.73x30.12)	1,795x1,695x765 (70.67x66.73x30.12)
	Shipping Dimensions (WxHxD)	mm (inch)	1,900x1,887x919 (74.80x74.29x36.18)	1,900x1,887x919 (74.80x74.29x36.18)	1,900x1,887x919 (74.80x74.29x36.18)	1,900x1,887x919 (74.80x74.29x36.18)
Operating Water Temp. Range	Cooling	°C (°F)	5 ~ 25 (41~77) (Brine, -10~25) (14~77°F)	5 ~ 25 (41~77) (Brine, -10~25) (14~77°F)	5 ~ 25 (41~77) (Brine, -10~25) (14~77°F)	5 ~ 25 (41~77) (Brine, -10~25) (14~77°F)
	Heating	°C (°F)	25 ~ 55 (77~131)	25 ~ 55 (77~131)	25 ~ 55 (77~131)	25 ~ 55 (77~131)
Operating Amb. Temp. Range	Cooling	°C(°F)	-15 ~ 48 (5~118)	-15 ~ 48 (5~118)	-15 ~ 48 (5~118)	-15 ~ 48 (5~118)
	Heating	°C(°F)	-25 ~ 43 (-13~109)	-25 ~ 43 (-13~109)	-25 ~ 43 (-13~109)	-25 ~ 43 (-13~109)

* Certified efficiency data in accordance with AHRI Standard 550/590.

* Specification may be changed without further notification.

3. Disassembly and Reassembly

3-1 Necessary Tools

Item	Remark
+SCREW DRIVER	
MONKEY SPANNER	
-SCREW DRIVER	
NIPPER	
ELECTRIC MOTION DRIVER	
L-WRENCH	



3-2 Disassembly and Reassembly

3-2-1. AG010/015KSV***

No.	Parts	Procedure	Remark
1	Electrical equipment parts	<p>1) Remove 24 screws from the Cabinet. (Use + Screw Driver)</p> <p>2) Remove the 8 screws and then separate the left side Cover Control Box of Hydro part and right side Cover Control Box of Inverter part. (Use + Screw Driver)</p> <p>3) Remove the Power, Compressor, Valve, Motor, Sensor connector of Assy PCB.</p>	  

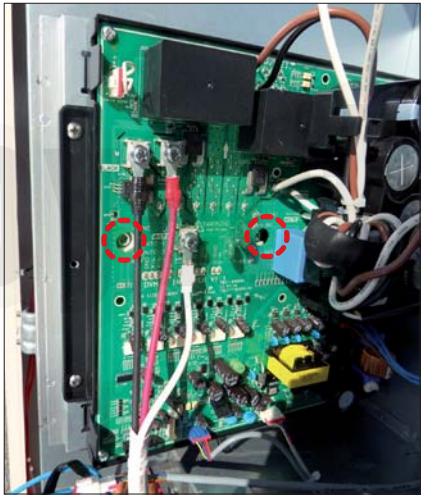
No.	Parts	Procedure	Remark
		<p>4) When replacing the Power Terminal Block and Communication Terminal Block, remove the 2 screws which is fixed to Terminal Block Cover.</p> <p>5) Remove the 4 screws which is fixed to Cabinet for Terminal Block protection and then remove the 2 screws from the Terminal Block.</p> <p>6) Remove the 5 screws from the front part..</p>	 <p>The first photograph shows the internal components of a terminal block assembly, including a green PCB, various cables, and a metal cover. Two red dashed circles are positioned on the right side of the metal cover, indicating the locations of screws to be removed.</p> <p>The second photograph is a close-up view of the terminal block assembly, showing the internal wiring and components. Five red dashed circles are positioned around the assembly, indicating the locations of screws to be removed.</p> <p>The third photograph shows the internal components of the terminal block assembly from a different angle, with five red dashed circles indicating the locations of screws to be removed.</p>

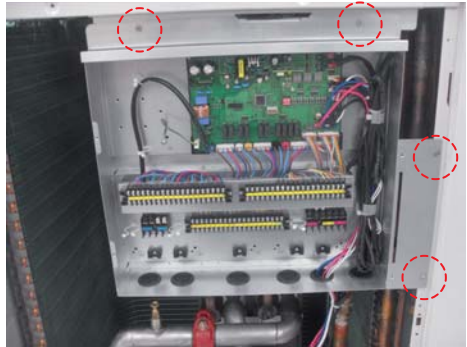
No.	Parts	Procedure	Remark
		<p>7) Remove the 12 screws from the outside of side refrigerant cooling part.</p> <p>⚠ Do not separate Heat Sink pulling Assy Piping Cooling piping compulsorily. (It can be a cause of parts damage)</p> <p>8) Remove the 2 screws from the inside of side refrigerant cooling part.</p>	 

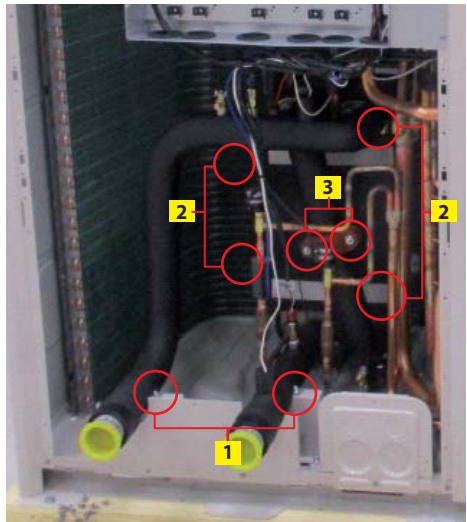
No.	Parts	Procedure	Remark
3	Hydro part Control Box	9) Remove the 4 screws from the front part.	
4	Trans Box (It correspond to J power model AG010/015KSVAJH)	10) Remove the 3 screws from the front part and then separate the Trans Box Cover. 11) Remove the 4 screws from the top of front part.	 
5	Hydro part	12) Remove the 4 screws which is fixed to Bracket Tube. 13) Remove the 4 screws which is fixed to Bracket Hydro part. 14) Remove the 2 screws securing the coupling points. Loosen BRACKET PHE SCREW where to hold the heat exchanger.	

No	code	SPEC	Q'ty
1	6003-001053	M6	2
2	6009-001369	M4	4
3	General NUT	M8	2

3-3 Service work of main parts

3-3-1. Temperature sensor & Pressure sensor in the water pipe side

- Exchange method of the water temperature sensor

<p>1) Power off before starting on work. 2) Unscrews the fixed screw of CABINET FRONT and C-BOX. 3) Separate the connector from PBA</p>	
<p>4) Separate Insu protecting the temperature sensor.</p>	 
<p>5) Separate the temperature sensor by using spanner.</p>	
<p>6) Separate the temperature sensor. It is applied Thermal Grease for an accurate temperature measurement.</p> <p>※ Cover the temperature sensor with Insu so that it is not affected from the outside.</p> <p>- Bolt torque : $120 \pm 10\%$ kgfcm</p>	

- Exchange method of the pressure sensor

- 1) Power off before starting on work.
- 2) Close the valve connected to inlet/outlet of main water pipe.
- 3) Drain all water of water pipe connected to DVM CHILLER.
- 4) Unscrews the fixed screw of CABINET FRONT and C-BOX.
- 5) Separate the connector from PBA.

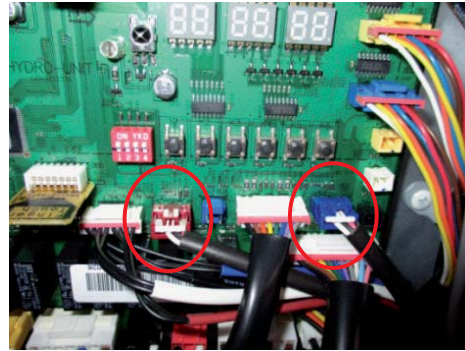

- 6) Separate the pressure sensor by using spanner.



- 7) Replace with the new pressure sensor.
Bolt torque : $120 \pm 10\%$ kgfcm



3-3-2. Plate type heat exchanger PHE

- 1) Power off before starting on work.
- 2) Close the valve connected to inlet/outlet of main water pipe.
- 3) Drain all water of water pipe connected to DVM CHILLER.
- 4) Unscrews the screw of inlet/outlet water pipe connected to DVM CHILLER.
- 5) Unscrews the fixed screw of CABINET FRONT.
- 6) Separates wire of cycle parts connected to ASSY PHE from C-BOX.



- 7) Connect the refrigerant reclaiming in the charging port, Recovering the refrigerant sealed in the product. Use only charging port charging, recovery of refrigerants.



- 8) Separate the four points of the pipe connected to ASSY PHE by welding .



9) Unscrew the screw of coupling connecting the two PHE in series.



- 10) Separate 6 screws of Bracket fixing ASSY PHE.
11) Please reassemble in reverse order of disassembly.
- Bolt torque at time of coupling tightening : $200 \pm 10\%$ kgfcm

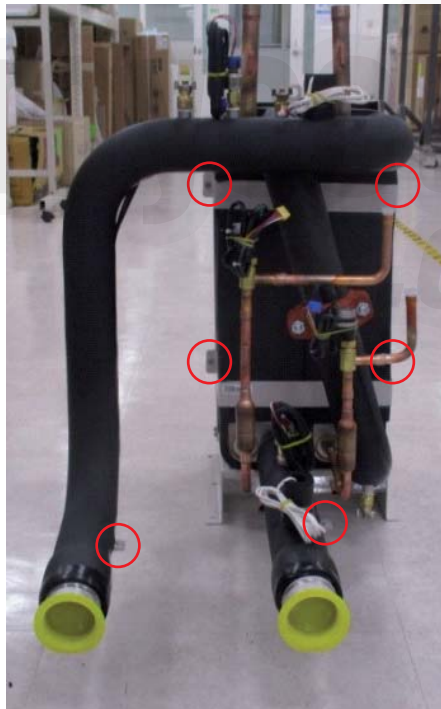

Binding Wire1

■ AG010/015KSV*** Series

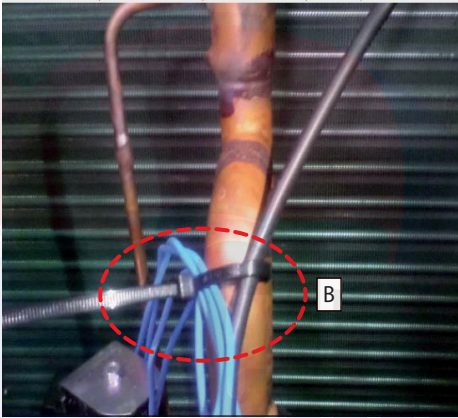
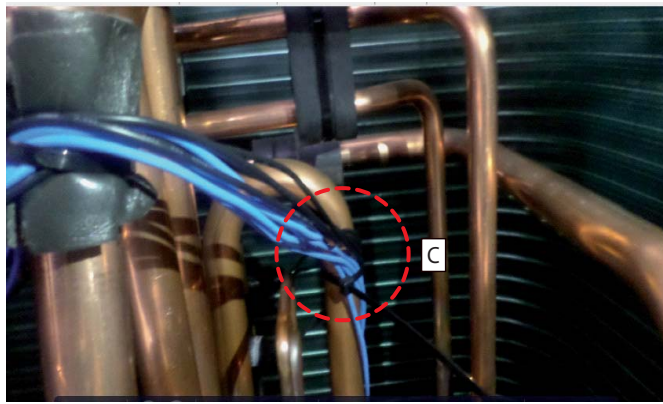

Ⓢ Cable Tie
 ○ Holder Wire
 ○ Etc.

location	Specifications	Used parts
A	Binds a EEV, Pressure sensor, Temperature sensor, Water temperature sensor by Cable-Tie.	6501-001110 (L200) : Cable Tie
B	Binds a High pressure switch, Oil return valve by Cable-Tie using Insu.	
C	Binds a High pressure sensor, EVI, Hot gas valve by Cable-Tie using Insu.	

Binding Wire2

■ AG010/015KSV*** Series

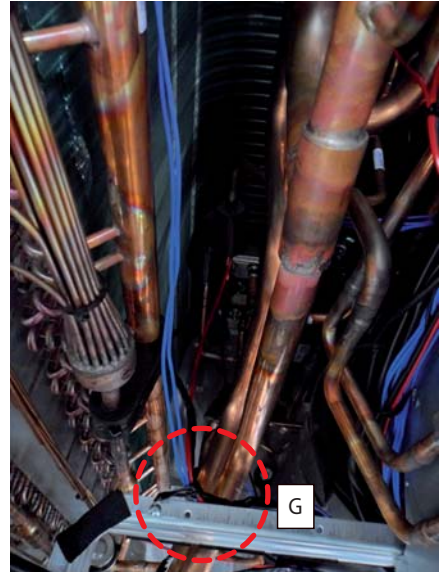
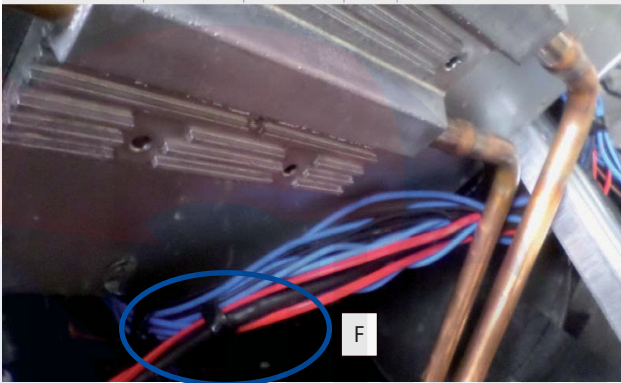
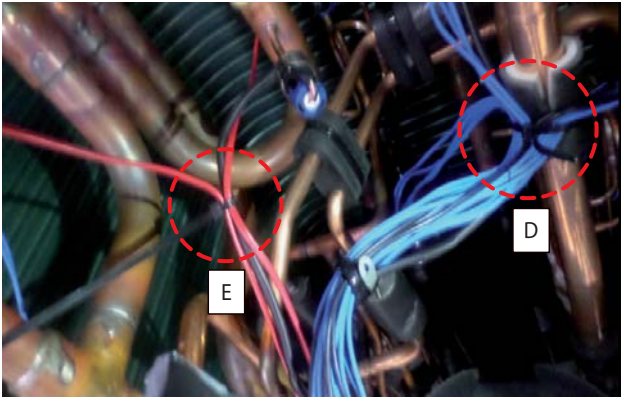

⊖ Cable Tie
 ○ Holder Wire
 ○ Etc.

location	Specifications	Used parts
D	Binds a Vapor injection valve, High-voltage switch, Oil return valve, High pressure sensor, EVI, Hot gas valve by Cable-Tie using Insu.	6501-001110 (L200) : Cable Tie
E	Binds a Low pressure sensor , Temperature sensor bundle by Cable-Tie.	
F	Binds a Vapor injection valve, High-voltage switch, Oil return valve, High pressure sensor, EVI, Hot gas valve, Low pressure sensor , Temperature sensor by Holder wire.	6501-001107 (L368) : Cable Tie
G	4Way valve, EVI EEV valve	

Binding Wire3

■ AG010/015KSV*** Series

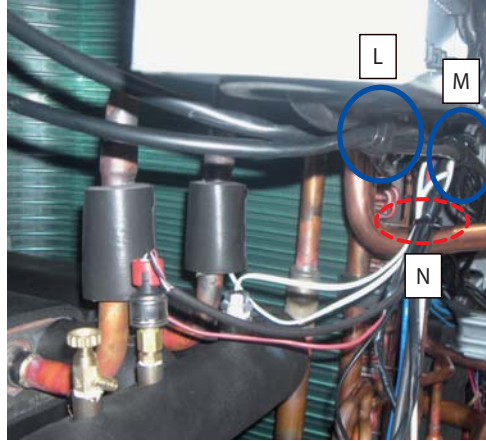
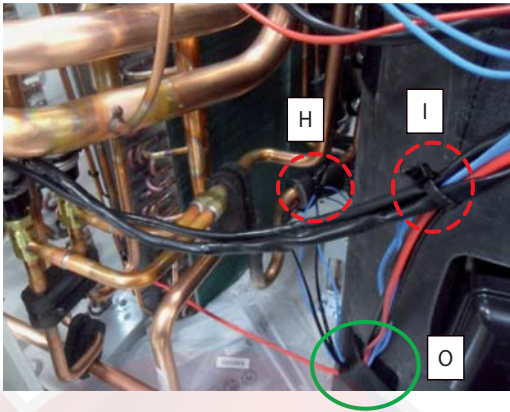

⊖ Cable Tie
 ○ Holder Wire
 ○ Etc.

Climaproyectos.com

location	Specifications	Used parts
H	Binds a Sub cooler temperature sensor 2 kinds by Cable-Tie.	6501-001107 (L368) : Cable Tie
I	Binds a EEV coil, Cond out temperature sensor, Sub cooler temperature sensor 3 kinds, Oil return valve by Cable-Tie.	
J	Binds a Communication wire, Power wire, Motor wire, Suction temperature sensor by Holder wire.	DB61-00206A
K	Binds a Communication wire, Power wire, Motor wire, Suction temperature sensor by Holder wire.	
L	Binds a Motor wire, Power wire by Holder wire.	
M	Binds a Motor wire, Power wire, Communication wire, Hydro part wire bundle by Holder wire.	
N	Binds a Hydro part wire bundle by Holder wire.	FELT VELCRO
O	COND OUT, ACCUM OIL RETURN VALVE, Temperature Sensor 2 kinds	

Binding Wire4

■ AG010/015KSV*** Series

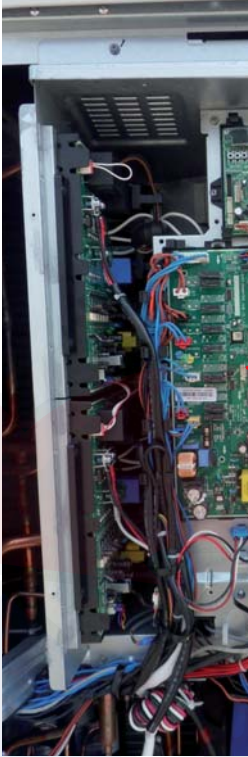

Binds a Comp wire by Holder wire.

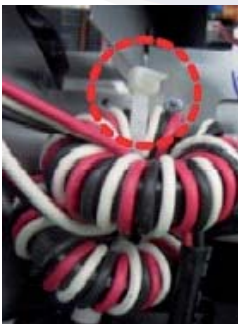

Binds a Comp wire-core to Bracket beam control box using large size Cable-Tie(350mm).

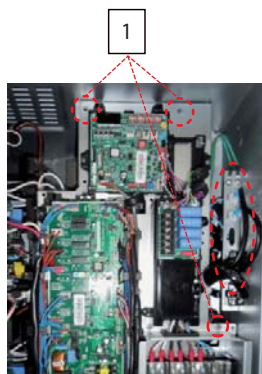

No	Code	SPEC	Q'ty
1	6002-001149	M4	3



Remove the 3 screws and separate the connector and then separate the double layer structure of Control Box.

[Reference Sheet]

Pipe Welding Position

■ AG010/015KSV*** Series

Front welding part 2

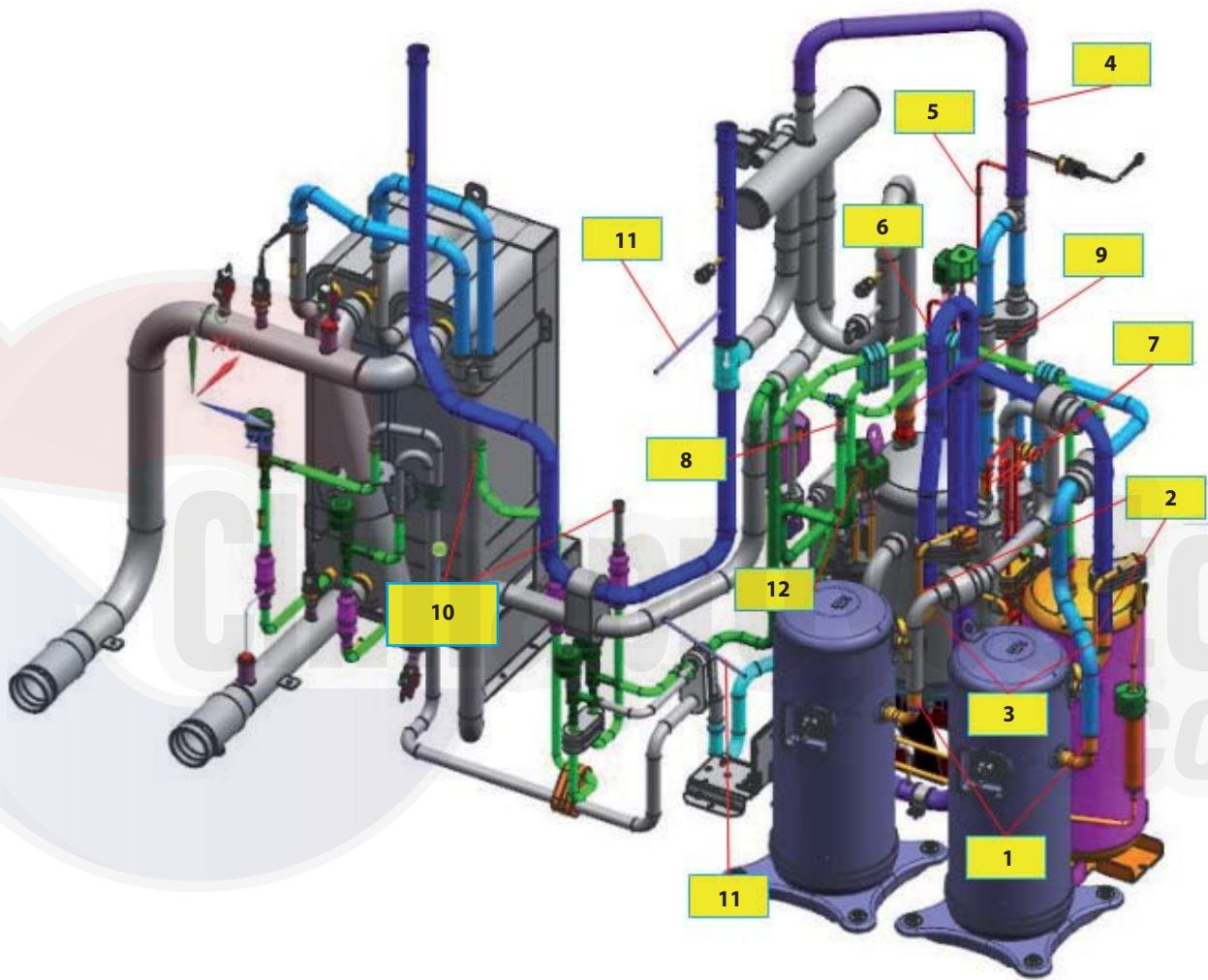

※ All model's pipe welding position is same.

No.	Welding Position	Q'ty
1	Comp + Discharge	2
2	Comp + Suction	2
3	Comp + Vpaor Injection	2
4	Oil Sepa Out + 4way	1
5	Oil Sepa Out + Hot Gas	1
6	4Way + Hot Gas	1
7	Sution + Oil Return	2
8	Vapor Injection + EVI Bypass	1
9	Accum + 4Way	1
10	EEV + Cond Out	2
11	Pinch Pipe	2
12	Subcooler + Receicer Tube	1

[Reference Sheet]

Pipe Welding Position

■ AG010/015KSV*** Series

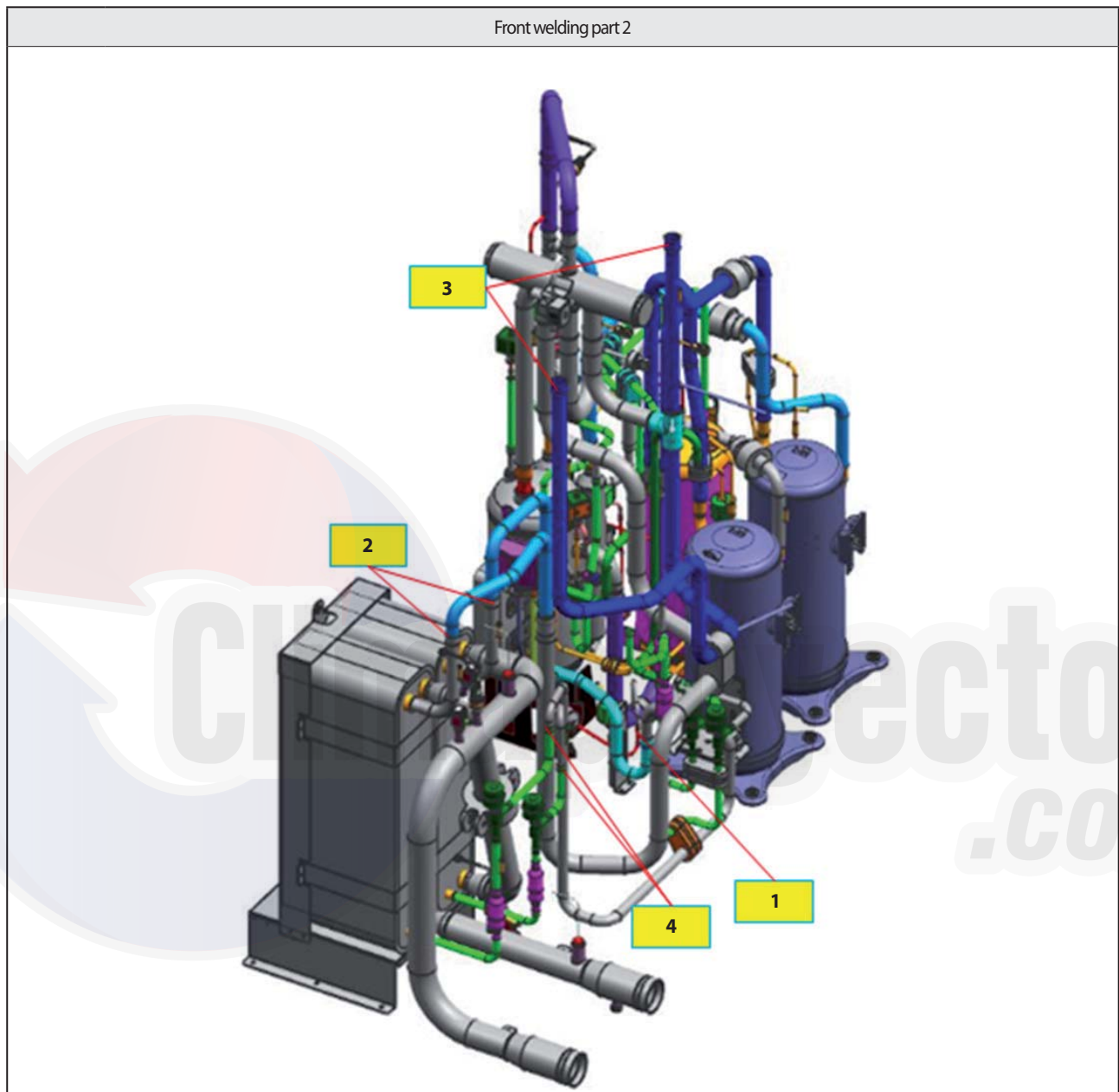

※ All model's pipe welding position is same.

No.	Welding Position	Q'ty
1	Accum Oil Retrun valve + Suction	1
2	4Way + Assy Phe In	2
3	4Way + Cond In	2
4	EEV + Assy Phe Out	2

[Reference Sheet]

Pipe Welding Position

■ AG010/015KSV*** Series

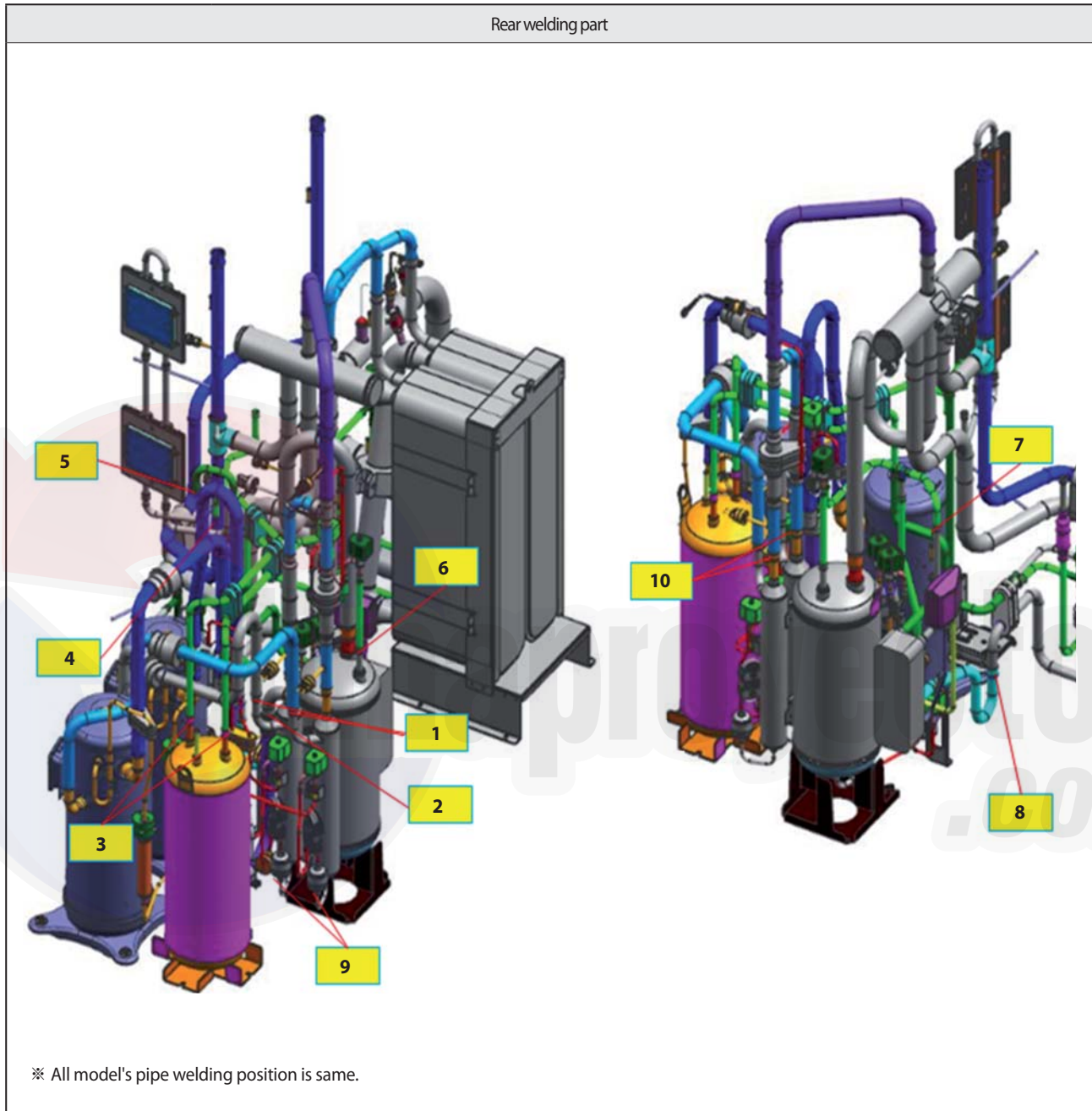

No.	Welding Position	Q'ty
1	Discharge + Oip sepa Tank	2
2	Suction + Accum	1
3	Receiver Tank + Receiver Tube	2
4	Receiver Tube + Cooling	1
5	Cooling + EEV	1
6	Accum + EVI Bypass	1
7	EVI Bypass + Subcooler	1
8	Subcooler + EEV	1
9	Oil Sepa tank + Oil Return	2
10	Oil Sepa tank + Oil Sepa out	2

4. Troubleshooting

4-1 Check-up Window Description

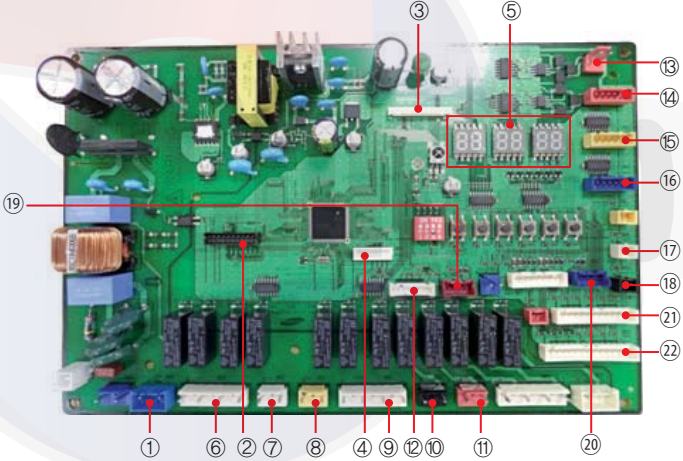
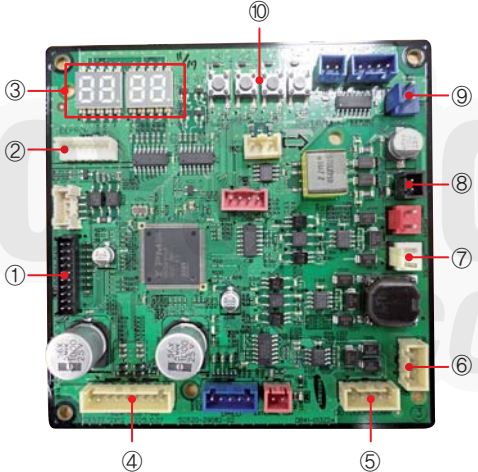

Hydro control				Inverter control			
							
No.	Function	No.	Function	No.	Function	No.	Function
1	Input power	12	Input EVA1,2 Temperature sensor	1	MICOM Download	6	Indoor unit Communication
2	MICOM Download	13	Communication between Hydro and Heat source unit (F1,F2)	2	EEPROM Socket	7	Solution Communication
3	2 wire communication SUB PCB Connection	14	Module communication, Controller (OF1,OF2,V1,V2,F3,F4)	3	State/Error Display	8	5V
4	EEPROM Connection	15	EEV2	4	HUB PCB Connection	9	12V
5	State/Error Display	16	EEV1	5	Outdoor unit Communication (N/A)	10	Tact Switch
6	Cooling/Heating display, Operation Display	17	Input water in Temperature sensor				
7	Warning Display	18	Input water out Temperature sensor				
8	Defroster operation Display	19	Input PHE OUT Pressure sensor				
9	Pump, Compressor operation Display	20	Input PHE IN Pressure sensor				
10	Pump operation	21	Pump interlock, Control peration/Mode heat storage operation/Control				
11	Freeze protection Display	22	Quiet function, Demand function Forced fan function, Unusual condition reset, Water law				

4-2. Service Operation

4-2-1. Special Operation

- ▶ Key input of the outdoor unit when the service enters the operation mode.

K1 (Number of press)	KEY operation	Display on 7-Segment
1times	Refrigerant charging in Heating mode	"8" "8" "8" "8"
2times	Trial operation in Heating mode	"8" "2" "8" "8"
3times	Refrigerant discharging in Heating mode	"8" "3" "8" "8"
4times	Disuse	"8" "3" "8" "2"
5times	Disuse	"8" "3" "8" "3"
6times	Disuse	"8" "3" "8" "4"
7times	Vacuum	"8" "3" "8" "8"
8times	Disuse	"8" "4" "8" "2"
9times	Disuse	"8" "3" "8" "3"
10times	Disuse	"8" "3" "8" "8"
11times	Disuse	"8" "4" "8" "8"
12times	End KEY operation	-

K2 (Number of press)	KEY operation	Display on 7-Segment
1times	Refrigerant charging in Cooling mode	"8" "5" "8" "8"
2times	Trial operation in Cooling mode	"8" "6" "8" "8"
3times	Pump down all units in Cooling mode	"8" "0" "8" "8"
4times	Auto trial operation	"8" "8" "8" "8"
5times	Checking the amount of refrigerant	"8" "8" "X" "X" (Display of last two digits may differ depending on the progress)
6times	Discharge mode of DC link voltage	"8" "8" "8" "8"
7times	Forced defrost operation	"8" "8" "8" "8"
8times	Forced oil collection	"8" "2" "8" "8"
9times	Inverter compressor 1 check	"8" "8" "8" "8"
10times	Inverter compressor 2 check	"8" "8" "8" "8"
11times	Fan 1 check	"8" "8" "8" "8"
12times	Fan 2 check	"8" "0" "8" "8"
13times	End KEY operation	-

- ▶ To use key operating function for service and maintenance when installing module/group, set as main control or cancel in module/group.

(Body control settings : Hydro control Dip S / W 1 times On,
Modules / How to ungroup : Modular Controller Installation Manual Reference)

- ▶ During Discharging mode, voltage of Inv1 and Inv2 will be displayed alternately.
- ▶ Even when the power is off, it is dangerous when you come in contact with inverter PCB, fan PCB since high pressure DC voltage is charged to those parts.
- ▶ When replacing or repairing the PCB, cut-off the power and wait until the DC voltage is discharged before replacing/repairing them. - Wait for more than 15 minutes to allow those parts to be fully discharged.
- ▶ When there is error, Discharge mode of DC link voltage may not have been effective. Especially when E464 and E364 error is displayed, power element might be damaged so do not use the Discharge mode of DC link voltage.

■ Trial Operation

- ▶ After initial installation, stable operation for a certain period of time limited to operation conditions.

	Cooling	Heating
Method of Entry	K2 Tact Switch 2times	K1 Tact Switch 2times
Compressor	Normal operation, but the maximum frequency limit (differ by model)	
Fan and Valves	Normally control conduct	
Operation time	Min : 60 minutes, Max : 10 hours	
Etc.	<ul style="list-style-type: none"> · Exceed the maximum operating time at stops and waits. · Protection and control, self-diagnosis is performed. 	

■ Refrigerant Filling Operation

- ▶ Operation to filling the refrigerant compressor was fixed at a certain frequency.

	Cooling	Heating
Method of Entry	K2 Tact Switch 1times	K1 Tact Switch 1times
Compressor	Starting frequency (Mild Start frequency) operation	
Fan and Valves	Normally control conduct	
Maximum Operation time	60minutes	
Etc.	During the filling operation does not enter the special operation, such as oil recovery, defrost.	

■ Vacuum Operation

- ▶ Operation to facilitate vacuum to open the valve after the Outdoor Unit repair.

Method of Entry	K1 Tact Switch 7times
Compressor	OFF
Fan	OFF
4WAY Valve	OFF
Valves	Open all valves maximum
Etc.	If not turn off the vacuum mode, the start of normal operation is prohibited.

■ Discharge mode Operation

- ▶ Block the Inverter PCB 3-phase relay after connected the power, and through compressor, DC voltage is discharging.
 - Discharge Mode Operation Process : Push K2 button 6 times shortly.
 - INV1 and INV2 DC voltage during discharge mode are displayed alternately.
 - Discharge mode Display (Rotate the three page display, as shown below.)
 - 'E' 'E' ' ' ' ' → DC Link Volt1 (For example, 120[V] 0 1 2 0 display) → DCLinkVolt2 (For example, 120[V] 0 1 2 0 display)
 - 'E' 'E' ' ' ' ' → DC Link Volt1 ...
- ▶ If want operation again after complete discharge mode : Restart after K3 key to Reset or Power Reset.

■ **Forced defrost operation**

- ▶ Forced defrost operation : Is operation when Frost Formation occurs in the outdoor. (When carried out the service)

Method of Entry	K2 Tact Switch 7 times
Start pattern	Heating Trial Operation pattern
Defrost start	Defrost start : It is after 10 minutes which Safety Start finishes.
Defrost off	General defrost operation conditions are the same as.
Etc.	Defrost shut down and stop the normal pattern of the outdoor unit stop.

■ **Forced oil recovery operation**

- ▶ Forced oil recovery operation : Oil recovery in the outdoor unit for the purpose of moving, installation if necessary.

Method of Entry	K2 Tact Switch 8 times
Start pattern	Outdoor temperature is more than 10°C (50°F) : Cooling Auto Trial Operation. Outdoor temperature is less than or equal to 10°C (50°F) : Heating Auto Trial Operation.
Oil recovery start	Oil recovery start : It is after 10 minutes which Safety Start finishes.
Etc.	Oil recovery shut down and stop the normal pattern of the outdoor unit stop.

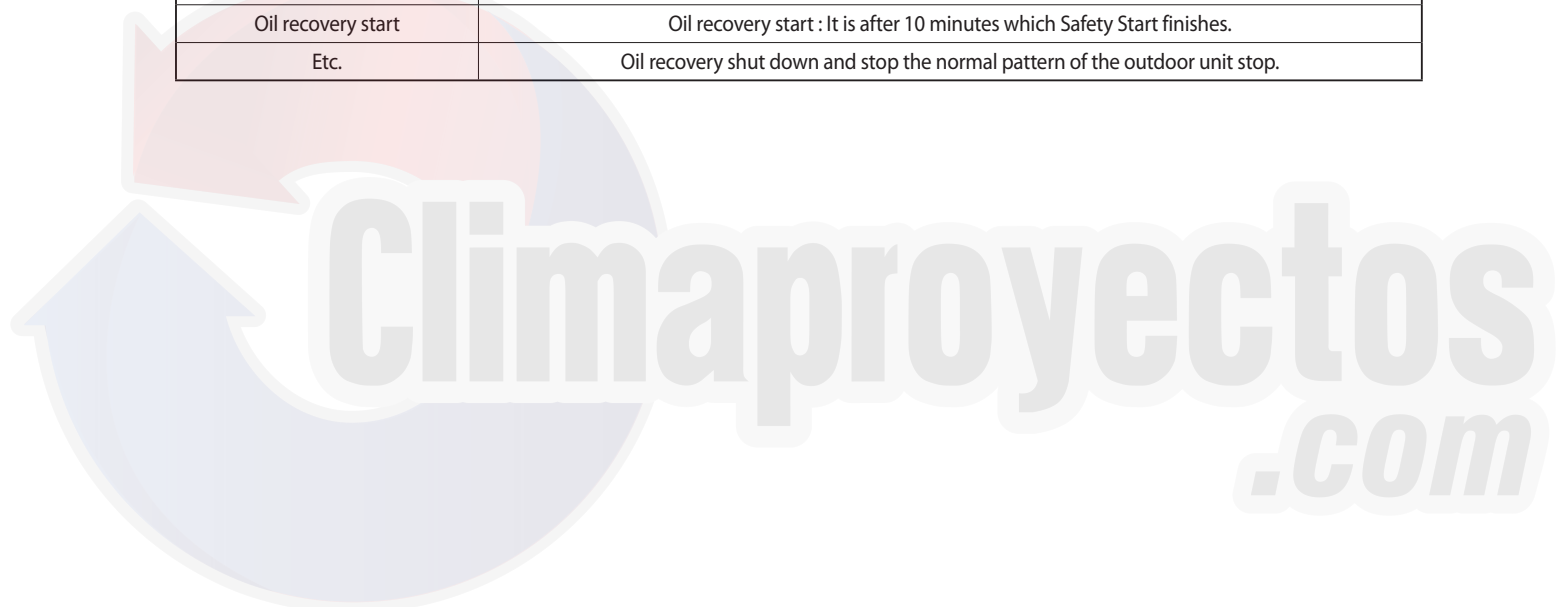

4-2-2. DVM Chiller EEPROM code table by models

No.	Model	EEP code
1	AG010KSVAFH/AA	DB82-03480A
2	AG015KSVAFH/AA	DB82-03481A
3	AG010KSVAJH/AA	DB82-03482A
4	AG015KSVAJH/AA	DB82-03483A

■ Method of PCB SW update and method of EEPROM download

SW update	Tool	Procedure
PC SW	S-net pro 2	<p>* Refer to the S-net pro 2 manual for more detailed information.</p> <p>Alt 1. UART Update</p> <ol style="list-style-type: none"> 1. Power down the system. 2. Connect download cable to PCB 3. Connect Converter to PC. 4. S-Net pro 2 - Add-on - UART Update <p>Alt 2. AC unit S/W update(Communication update)</p> <ol style="list-style-type: none"> 1. Power on the system. 2. Connect F1,F2 to converter. 3. Connect Converter to PC. 4. S-Net pro 2 - Connect - Add-on -AS unit Outdoor EEPROM write <p>* This work only when communication is normal.</p>
Converter	S-converter : OK I-converter : NG	
Cable	20PIN download cable	
Outdoor EEPROM writing	Tool	Procedure
PC SW	S-net pro 2	<p>* Refer to the S-net pro 2 manual for more detailed information.</p> <ol style="list-style-type: none"> 1. Power on the system. 2. Connect F1,F2 to converter. 3. Connect Converter to PC. 4. S-Net pro 2 - Connect - Add-on -Outdoor EEPROM write <p>* This work only when communication is normal.</p>
Converter	S-converter : OK I-converter : NG	
Cable	F1,F2 communication cable	

4-2-3. Option code by model classification

Item	Model	SEG																								Remark
		1	2	3	4	5	6	7	8	9	10	11	12	13	14	15	16	17	18	19	20	21	22	23	24	
F power resource	AG010KSVAFH/AA	0	1	0	0	4	4	1	2	7	9	0	A	2	3	2	3	2	3	3	0	0	0	0	3 Phase 3 Wires 208~230V, 60Hz	
	AG015KSVAFH/AA	0	1	0	0	4	4	1	2	7	9	0	B	2	3	3	2	3	2	3	3	0	0	0		
J power resource	AG010KSVAJH/AA	0	1	0	0	4	4	1	2	7	9	0	A	2	3	2	3	2	3	3	0	0	0	0	3 Phase 3 Wires 460V, 60Hz	
	AG015KSVAJH/AA	0	1	0	0	4	4	1	2	7	9	0	B	2	3	3	2	3	2	3	3	0	0	0		

4-2-4. Number Display Method

■ How to Display Integrated Error Code

▶ Meanings of First Alphabetical Character / Number of Error Code

DISPLAY	Explanation	
<i>E</i>	When displaying Error 101~700	
<i>C</i>	When E206 occurs	Displays address of subordinate within the set C001 : HUB, C002: FAN, C003: INV1, C004: INV2
<i>U</i>	When displaying outdoor unit address Ex) U200: Outdoor unit 1, U201: Outdoor unit 2, U202: Outdoor unit 3, U203: Indoor unit 4	
<i>A</i>	When displaying indoor unit address Ex) A000: Indoor unit address 0, A001: Indoor unit address 1, A002: Indoor unit address 2	

▶ Order of Error Display

Classification	Error display method	Display Example
Display method for error that occurred in indoor unit	Error Number → Indoor unit address → Error Number, repeat display	E471 → A002 → E471 → A002
Display method for error that occurred in outdoor unit and other methods of error display	Error Number → Outdoor unit address → Error Number, repeat display	E471 → U200 → E471 → U200 E206 → C001 → E206 → C002

■ Error display(Error Code)

► Segment will display error code (4 digit).

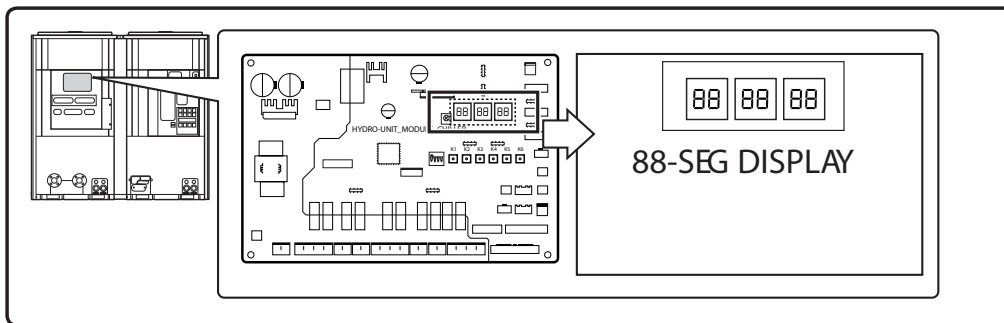

Display	Description
101	Communication error between hydro controller and inverter controller (If not received for 3 minutes from outdoor unit)
108	Error due to repeated setting address
109	Communication error of hydro controller address not complete
122	Error on hydro Evap in Sensor (Open/Short)
123	Error on hydro Evap out Sensor (Open/Short)
128	Error on hydro Evap in Sensor (Detached)
129	Error on hydro Evap out sensor (Detached)
144	Error on hydro pipe temperature 2 sensor
145	Error on hydro EVA OUT 2 sensor
151	Hydro EEV open error (2nd detection)
152	Error due to closed EEV of hydro (2nd detection)
153	Error on hydro floating switch (2nd detection)
162	Inverter controller EEPROM error
163	Hydro controller EEPROM option setting error
198	Error due to disconnected thermal fuse (Temperature of terminal block increases.)
201	Communication error between hydro controller and outdoor unit
202	Communication error between hydro controller and inverter controller (When there is no response from indoor units after tracking is completed)
203	Communication error of Main and sub MICOM of inverter controller
205	Communication error of inverter controller main PBA - sub PBA (Sub PBA communication all not received)
206	Communication error of inverter controller main PBA - sub PBA (S PBA communication partially not received) Specification of PBA display for actual communication error C001: Hub PCB communication error C002: Fan PCB communication error C003: INV1 communication error C004: INV2 communication error
221	Error on outdoor temperature sensor (Short or Open)
231	Error on COND outlet sensor (Short or Open)
241	COND outlet sensor is detached
251	Error on discharge temperature of COMP1 (Short or Open)
257	Error on discharge temperature of COMP2 (Short or Open)
262	Discharge temperature sensor of COMP1 is detached
263	Discharge temperature sensor of COMP2 is detached
266	Top1 temperature sensor is detached
267	Top2 temperature sensor is detached
269	Suction temperature sensor is detached
270	Suction 2 temperature sensor is detached
276	Error on Top 1 temperature sensor (Short or Open)
277	Error on Top 2 temperature sensor (Short or Open)
291	Error on high pressure sensor (Short or Open)
296	Error on low pressure sensor (Short or Open)
308	Error on Suction sensor (Short or Open)

■ Error display(Error Code)

Display	Description
311	Error on double layer pipe sensor (Short or Open)
321	EVI inlet temperature
322	EVI outlet temperature
323	Error on Suction 2 sensor (Short or Open)
326	Error on Total suction sensor (Short or Open)
346	Operation failure of Fan2
347	Unconnected error of Fan2
348	Lock error on Fan2
353	Overheated motor of Fan2
355	Error due to overheated IPM of Fan2
361	INV2 Comp starting error
364	INV2 DC Peak error
365	INV2 Comp Vlimit error
366	INV2 DC-Link voltage under/over error
367	INV2 Comp Rotation error
368	Error due to full current of INV2
369	INV2 DC Link sensor error
371	INV2 DataFlash error
374	INV2 IPM Heat Sink error
378	Error due to overcurrent of Fan2
383	Error due to special overcurrent of Fan2
385	INV2 input current error
386	Error due to over voltage/low voltage of Fan2
387	Hall IC error of Fan2
389	Outdoor fan2 overload stop
391	Fan2 Date Flash error
393	Fan2 DC output sensor error
396	Fan2 DC Link voltage sensor error
399	Heat sink temperature sensor error of Fan2
400	INV2 IPM OverHeat error
407	COMP down due to high pressure
410	COMP down due to low pressure
416	COMP down due to discharge temperature
425	Phase reversal or phase failure
428	COMP down due to compressor not controlled
438	EVI EEV open error
439	Error due to refrigerant leakage (Examine when system off)
440	Restriction of heating operation by outdoor temperature
441	Restriction of cooling operation by outdoor temperature
442	Restriction of heating charging operation by outdoor temperature
443	Operation prohibited due to low pressure
445	Error due to self-diagnosis of CCH
446	Operation failure of Fan1
447	Unconnected error of Fan1
448	Lock error on Fan1
452	Instant blackout error
453	Overheated motor of Fan1
455	Error due to overheated IPM of Fan1
461	INV1 Comp starting error
462	Compressor stop due to full current control or error due to low current on CT2
464	INV1 DC Peak error
465	INV1 Comp Vlimit error
466	INV1 DC-Link voltage under/over error
467	INV1 Comp Rotation error
468	Error due to full current of INV1

■ Error display(Error Code)

Display	Description
469	INV1 DC Link sensor error
471	INV1 Data Flash error
474	INV1 IPM Heat Sink error
478	Error due to overcurrent of Fan1
483	Error due to special overcurrent of Fan1
485	INV1 input current error
486	Error due to over voltage/low voltage of Fan1
487	Fan1 Hall IC error
489	Outdoor Fan1 overload OFF
491	Fan1 DataFlash error
493	Fan1 output sensor error
496	Fan1 DC link sensor error
499	Fan1 Heat Sink temperature sensor error
500	INV1 IPM OverHeat error
560	Switch option setting error
901	Hydro inlet temperature sensor (Tw1) Short/Open
902	Hydro outlet temperature sensor (Tw2) Short/Open
907	Frozen damage error
908	Error when freeze prevention Comp Off 3 times
909	Error when freeze prevention Comp Off 3 times
910	Error on hydro outlet temperature (Tw2) sensor (Detached)
911	Water Flow error (Water pressure sensor)
913	Flow Pressure sensor error (E911) occurs 6 times and reoccurs
918	Error on pump magnetic switch malfunction
971	External sensor (WaterOut Setting Device/ WaterLaw Room Temp sensor) is open/Short
972	Water inlet side pressure sensor is open/short
973	Water outlet side pressure sensor is open/short
974	External WaterOut sensor is open/short

4-3. Appropriate measures for symptoms

4-3-1. Reversed phase / No phase check (Outdoor unit with 3 phase power) – display *E425*

1. When the power is on, check the status of the power from the inverter.

Three-phase L1(R)-L2(S)-L3(T) order, regardless of the power connection on the inverter does not phase power (no phase) can occur.

In this case, E425 or E466 (E366) is displayed, and then air conditioner will then maintain normal conditions.

However) N phase must be connected properly.

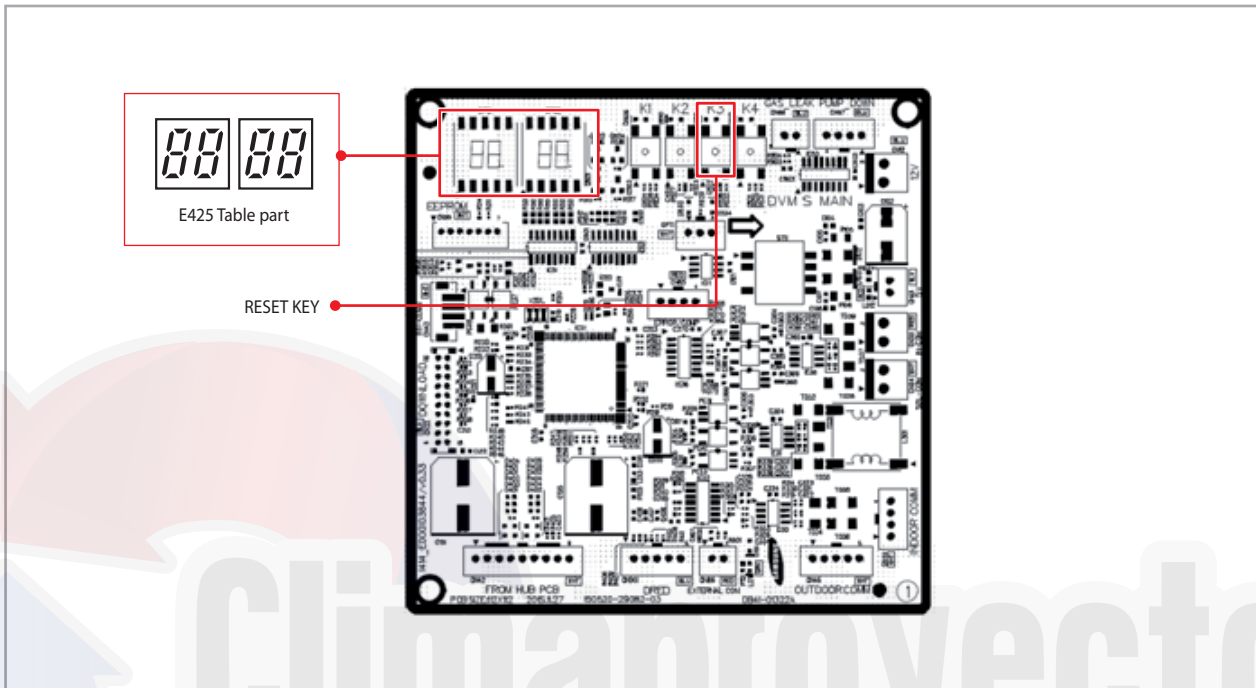

- 1) Check the voltage for L1 (R)-L2 (S) phase/L1 (R)-L3 (T) phase/L2 (S)-L3 (T) phase.
- 2) If there is any terminal without normal voltage, then check the power outside the air conditioner and take the appropriate measures.
- 3) If the 3-phase voltage is normal, then use the 3-phase tester to display the phase of the power cable.
Change the power cable connection if reversed phase is displayed.
- 4) Take the above measures, press the reset key (K3), and then check the power once more.
- 5) Check the EMI PCB Fuse connection and wiring.
- 6) If the same problem occurs after another check, check the Inverter PCB.



In case of wiring error (N-phase is changed with one of R, S and T) with the N-phase, will operate the power protection function, display E425 or stop the power. This is not a PCB power defect in this case, before PCB replacement, please check the power on.

■ Initial tracking (Communication check-up) - display *E201*

- The outdoor unit Micom attempts communication with the inverter control part connected to the communication wire (F1/F2) when the power is turned on.
- Basic segment display

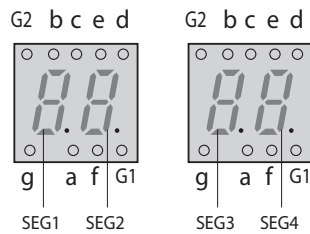

Display of inverter control part

Step	Display content	Display			
		SEG1	SEG2	SEG3	SEG4
At initial power input	Checking segment display	8	8	8	8
Chiller units Communicating Setting (Addressing)	Number of connected Chiller units	SEG1 A	SEG2 d	SEG3, 4 0	SEG3, 4 1
After communication setting (usual occasion)	Transmit / Reception address	Hydro control : A	Hydro control : 0	0	0

- Displays if communication fails, the inverter controller and Hydro control part *E201*.

4-3-2. Main PCB has no power phenomenon

Inverter / Hydro control part display	Main PCB has no power phenomenon (7-seg does not blink)
Judgment Method	Hub PCB power and connection wire to detect.
Cause of problem	1) HUB PCB connector wire defects and disconnection. 2) Main PCB defective. 3) Hub PCB defective. 4) High pressure switch operation

1. Inspection Method

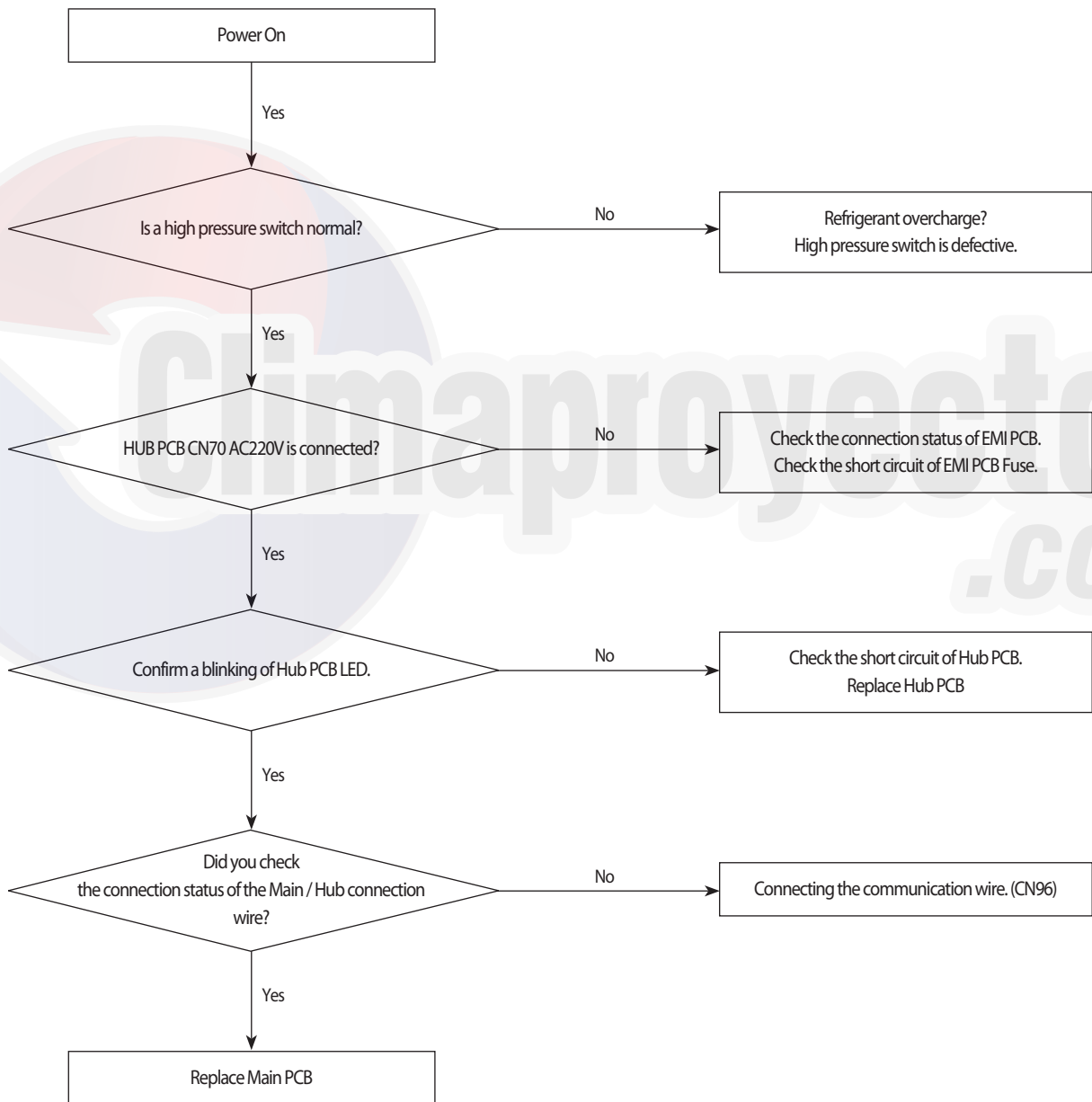

4-3-3. Communication error between hydro and outdoor unit during tracking

Inverter / Hydro control part display	E201
Judgment Method	Refer to the inspection method below.
Cause of problem	Communication error between indoor and outdoor units.

1. Inspection Method

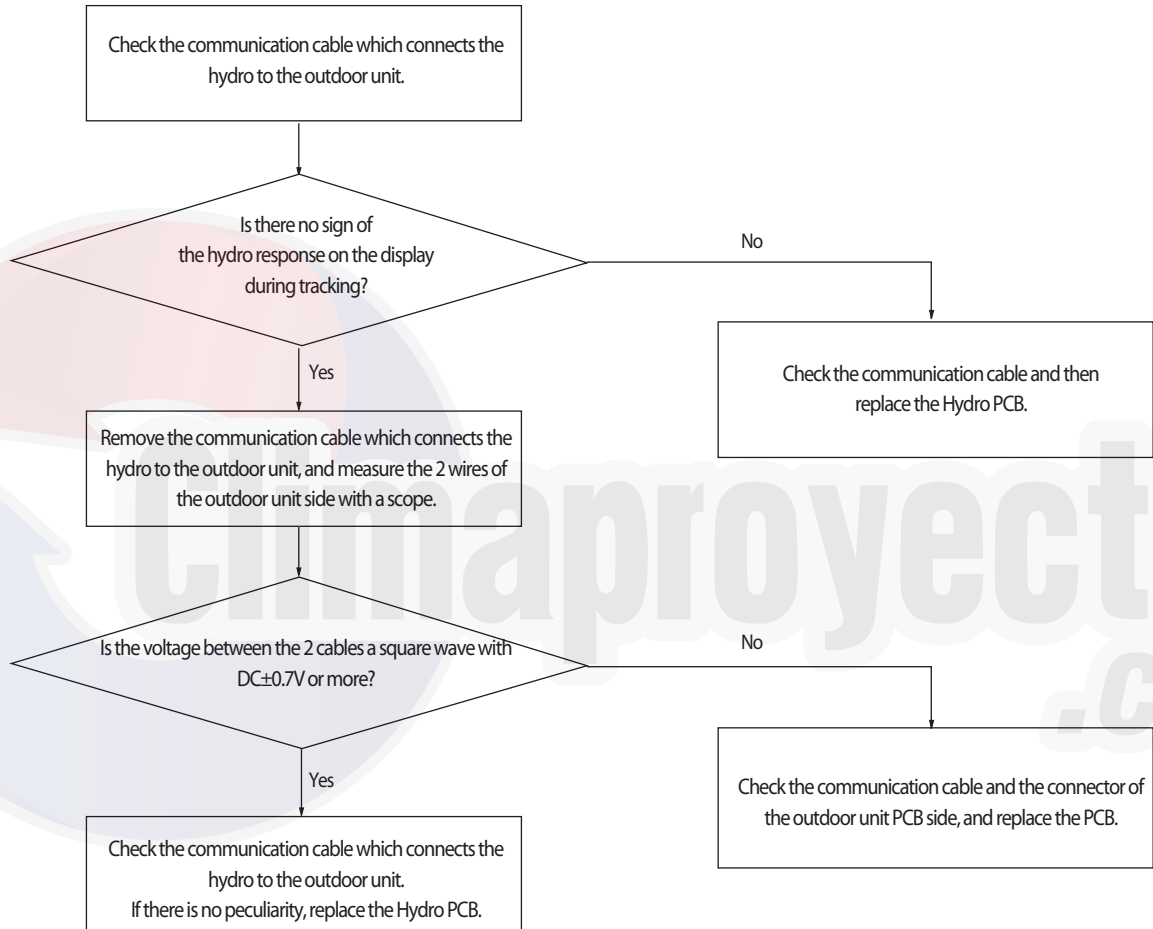

Essential check point before PCB replacement in case of communication error.

1. Find a communication IC nearby communication terminal.

- Hydro control part

- 1 - Communication IC between Hydro control part and inverter control part
- 2 - Communication IC between wired remote controller

- Inverter control part

- 3 - Communication IC between inverter control part and hydro control part
- 4 - Communication IC between inverter control part and high level controller
- 5 - N/A

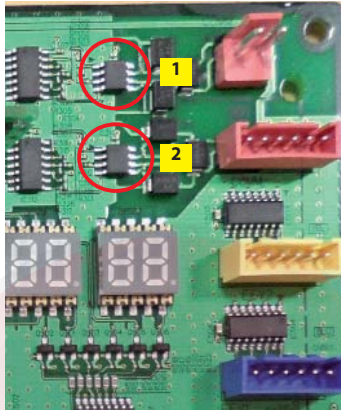

Hydro control part

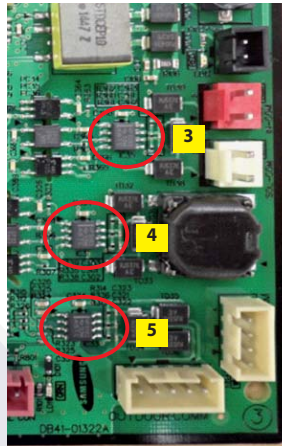

Inverter control part

2. Measure the resistance of the communication IC.

- Measurement Method : Measure No5. - No6. Pin resistance
Measure No5. - No7. Pin resistance

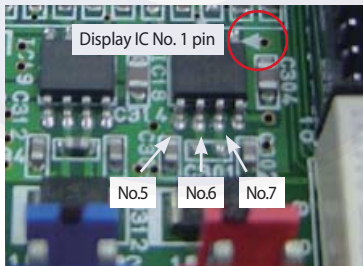

3. Normal and defective judgment is tested for communication IC by using measured resistance.

- Judgment as normal

- Each resistance value should be measured in tens of $k\Omega$ to hundreds of $k\Omega$.
- Difference between both resistance values should be in a few $k\Omega$.

- Judgment as defect

- One of the two or both value are low with tens of Ω .
- One of the two or both value is open.

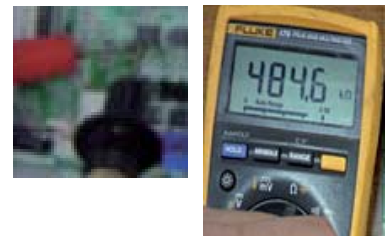

4-3-4. Communication error between indoor and outdoor unit after tracking

Inverter / Hydro control part display	E202
Judgment Method	If the hydro and outdoor unit is unable to communicate for 2 minutes during operation.
Cause of problem	Communication error between hydro and outdoor unit.

1. Inspection Method

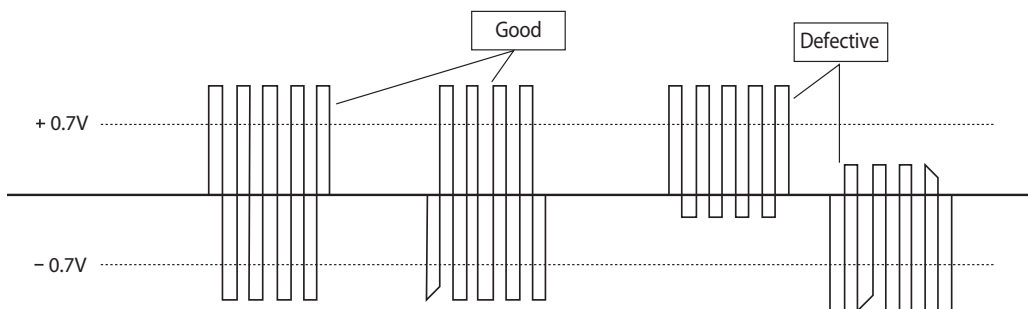
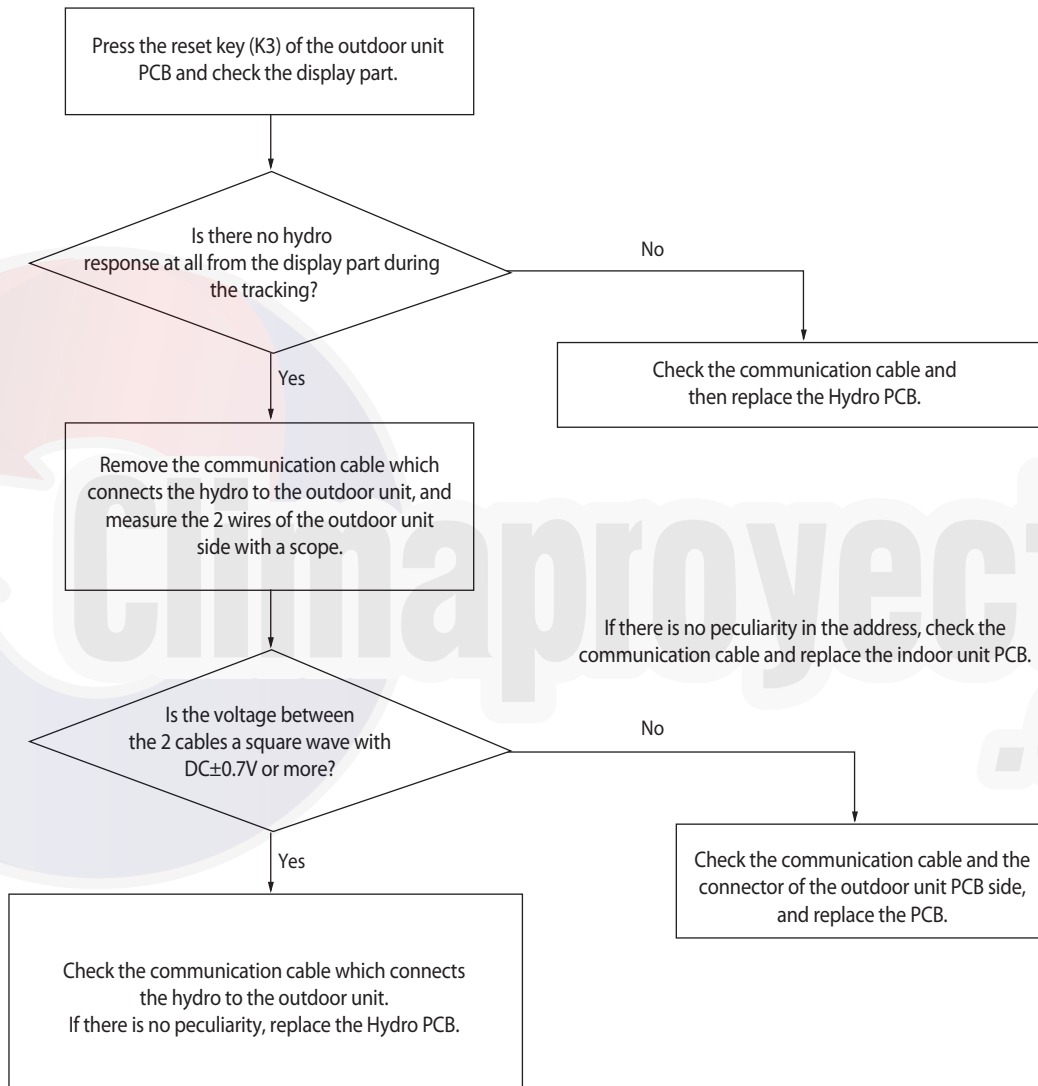

4-3-5. Internal communication error of the outdoor unit C-Box

Inverter / Hydro control part display	<i>E205</i>
Judgment Method	Communication error between the C-Box PCB
Cause of problem	<ul style="list-style-type: none"> · Communication wire inside the C-Box is unconnected · Main PCB defective

1. Inspection Method

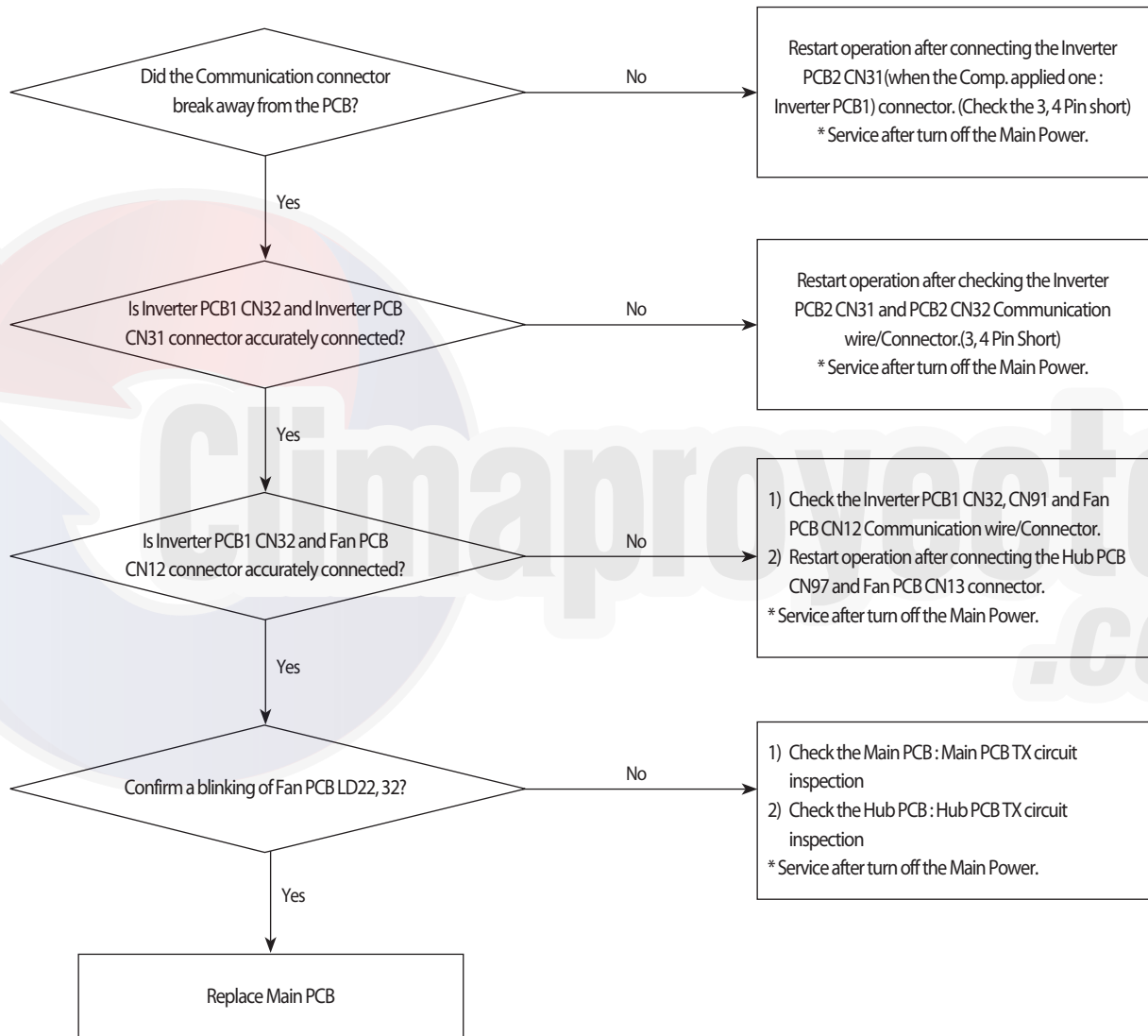

4-3-6. Internal PCB communication error of the outdoor unit C-Box

Inverter / Hydro control part display	<i>E206</i>
Judgment Method	PCB does not respond to the invoked Main PCB
Cause of problem	C-Box internal Inverter PCB, Fan PCB, Hub PCB defective

1. Inspection Method

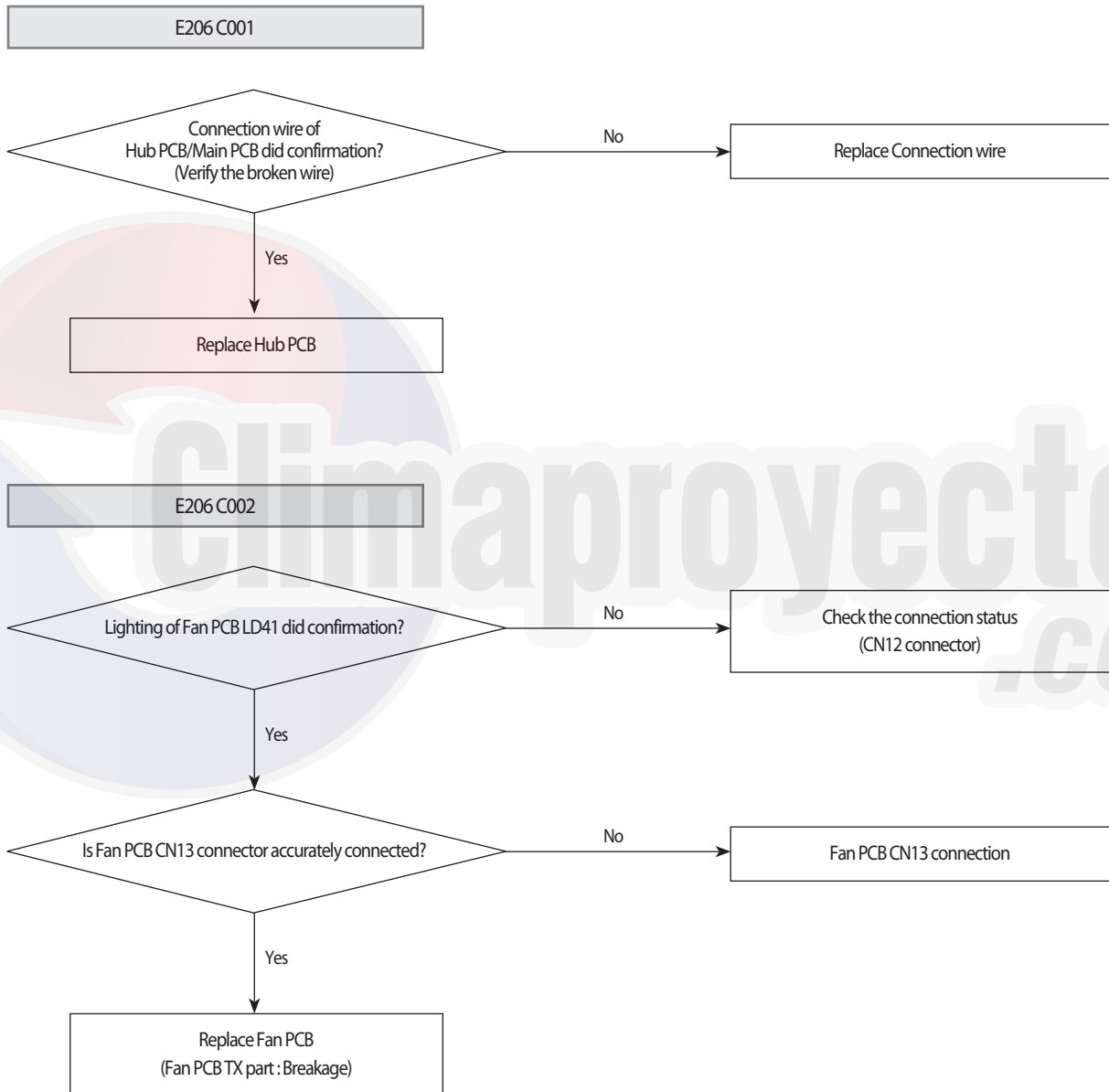

Internal PCB communication error of the outdoor unit C-Box (cont.)

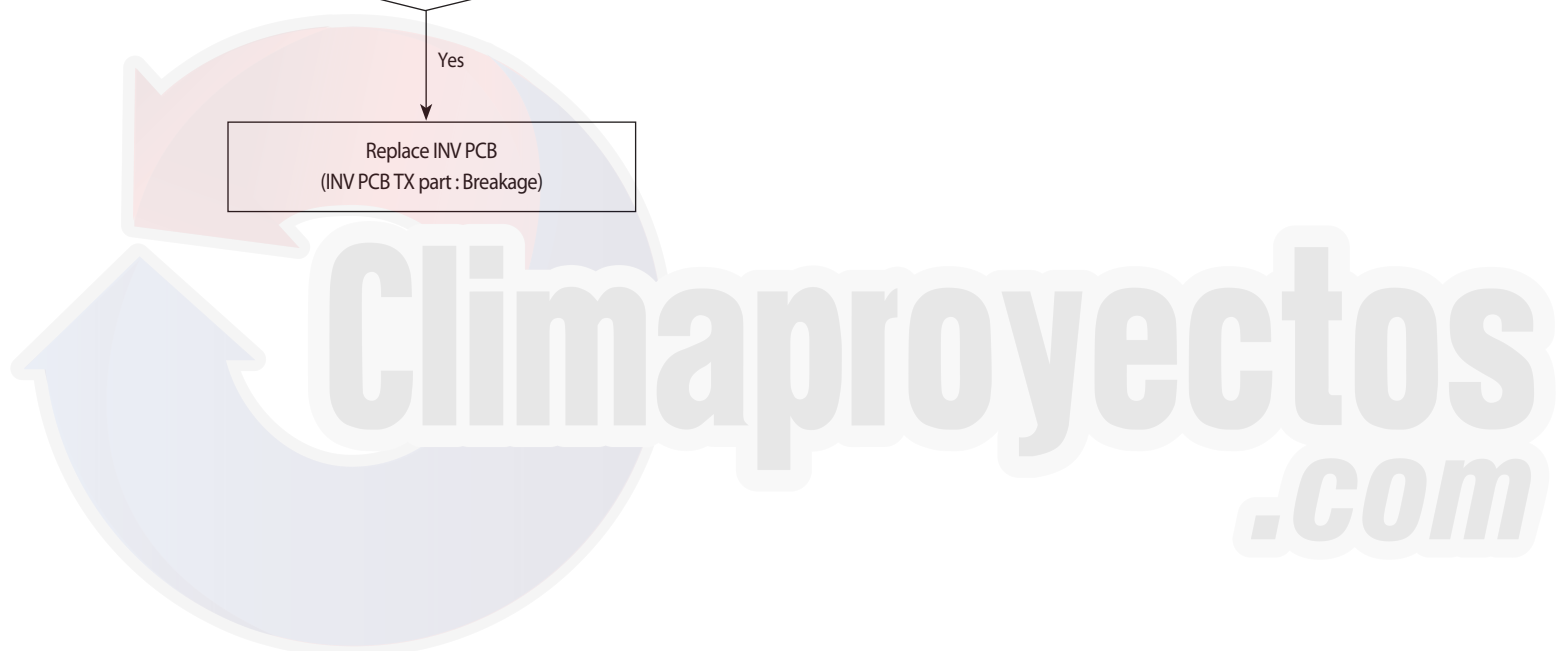
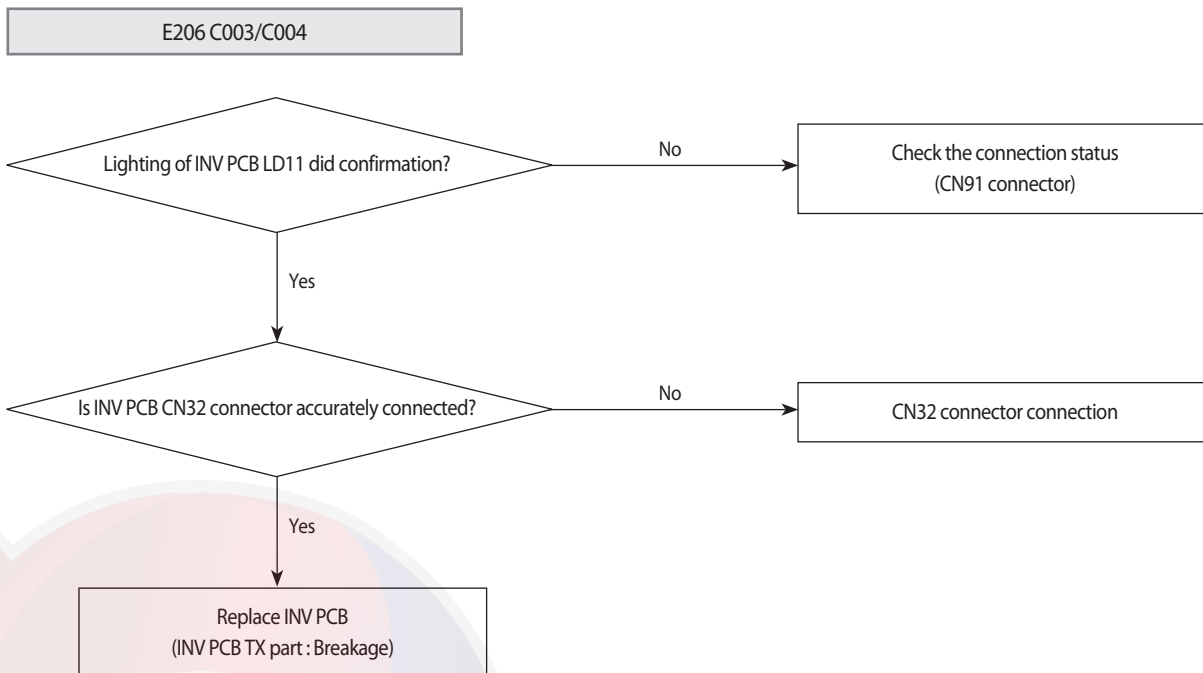

4-3-7. Outdoor temperature sensor error

Inverter / Hydro control part display	E221
Judgment Method	Refer to the inspection method below.
Cause of problem	Outdoor temperature sensor Open / Short is defective.

1. Inspection Method

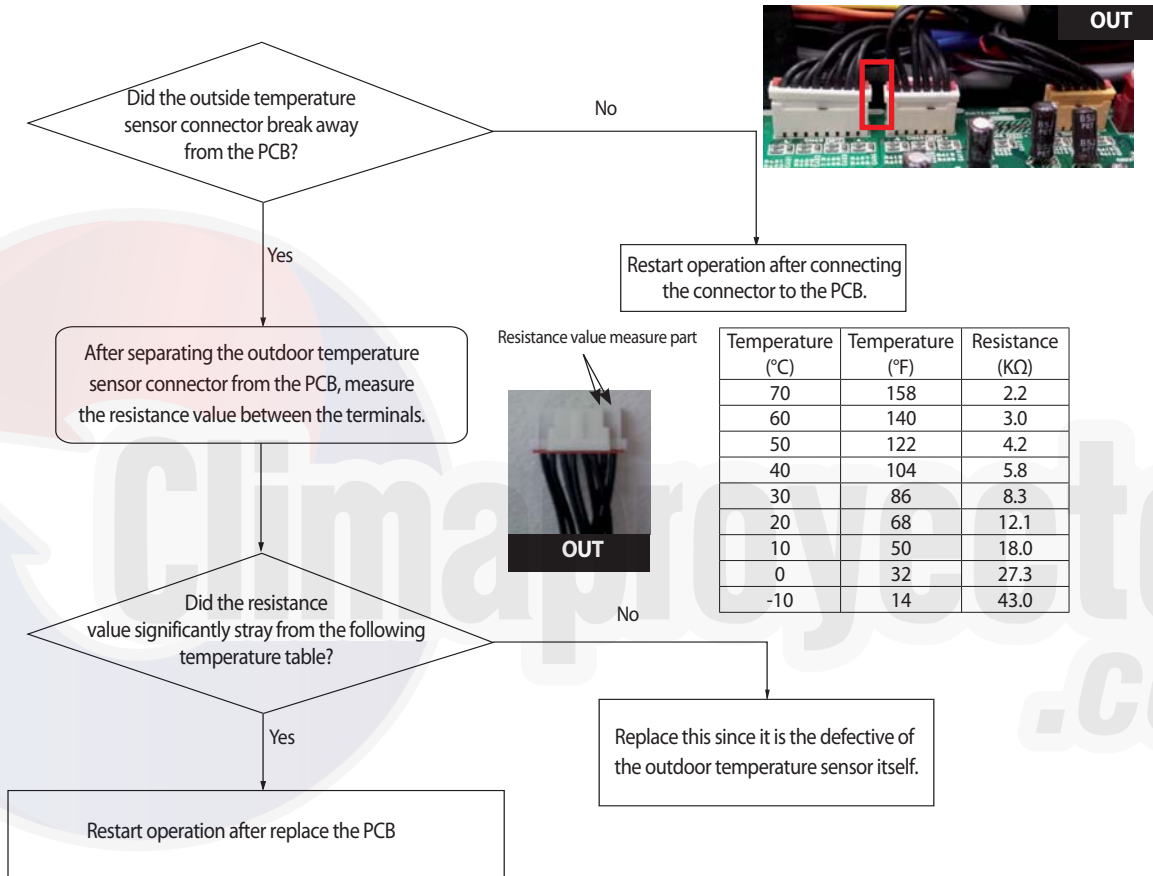

4-3-8. COND OUT temperature sensor error (Open / Short)

Inverter / Hydro control part display	E231
Judgment Method	Refer to the inspection method below.
Cause of problem	Disconnection or breakdown of relevant sensor.

1. Inspection Method

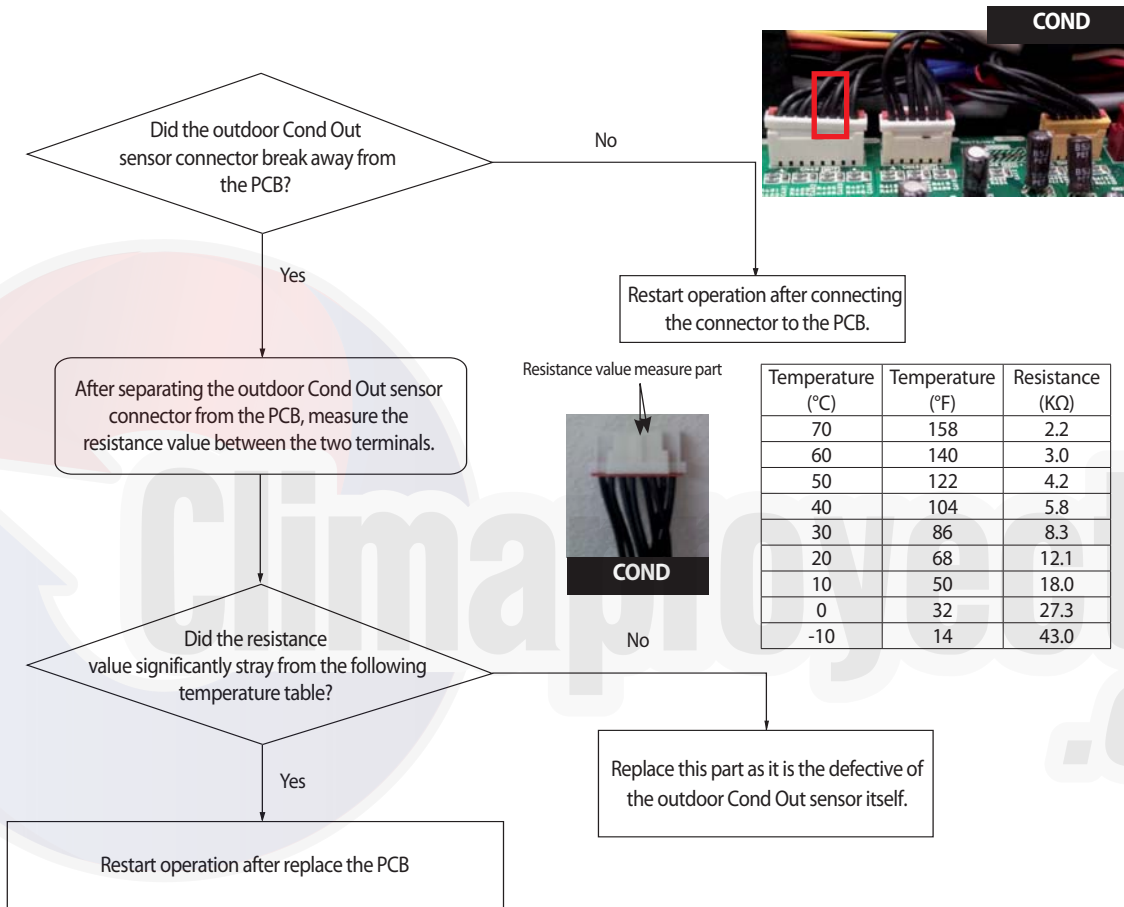

4-3-9. Outdoor unit COND OUT sensor breakaway error

Inverter / Hydro control part display	E241
Judgment Method	Refer to the inspection method below.
Cause of problem	Outdoor unit COND OUT sensor breakaway / defective / relevant path blocked.

1. Judgment Method

- 1) No inspection for Cooling operation.
- 2) For heating operation (Each of the conditions below needs to be satisfied for more than 20 minutes.)

High pressure average > 25 kgf/cm ² (355.6 psi)	OK
Low pressure average < 8.5 kgf/cm ² (120.9 psi)	OK
Teva, out - Tair, in ≥ 3°C (37.4°F)	OK
Teva, in - Tair, in ≥ 2°C (35.6°F)	OK
Tcond, out - Tair, out ≤ 0°C (32.0°F)	NO
Every compressor is in operation & indoor unit operation and Thermo On	OK
Error Content	Outdoor Cond Out sensor breakaway error

2. Cause of problem

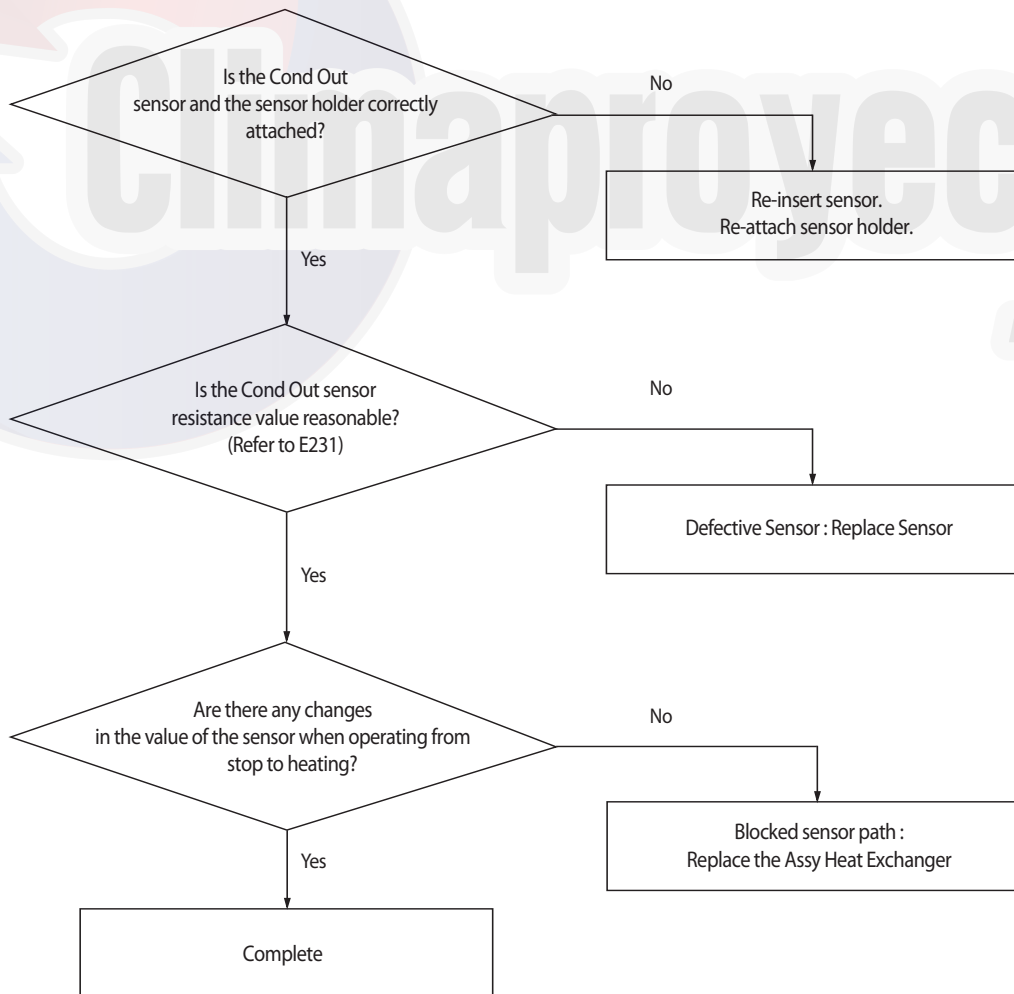

4-3-10. Compressor discharge or TOP 1/2 temperature sensor error

Inverter / Hydro control part display	<i>E251</i> (Compressor 1 Discharge) <i>E257</i> (Compressor 2 Discharge) <i>E276</i> (Compressor 1 TOP) <i>E277</i> (Compressor 2 TOP)
Judgment Method	Refer to the inspection method below.
Cause of problem	Compressor discharge or TOP temperature sensor defective. (Open / Short)

1. Inspection Method

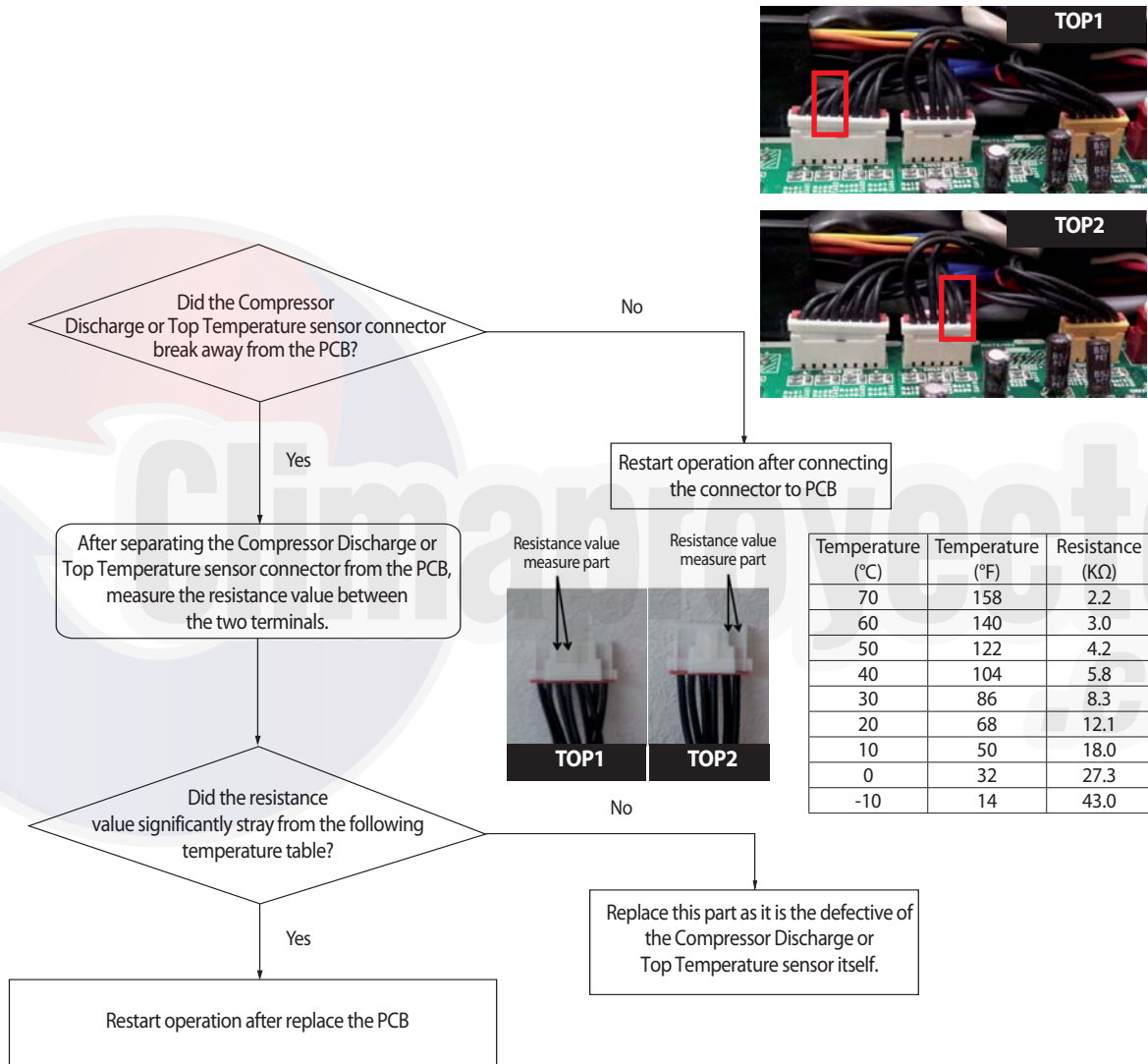

4-3-11. Compressor discharge or TOP temperature sensor breakaway error

Inverter / Hydro control part display	<i>E262</i> (Compressor 1 Discharge) <i>E263</i> (Compressor 2 Discharge) <i>E266</i> (Compressor 1 TOP) <i>E267</i> (Compressor 2 TOP)
Judgment Method	1) Relevant compressor frequency of 60Hz or higher. 2) Suction temperature > Low pressure saturation temperature + 10°C (18°F). 3) Relevant discharge or Top temperature < High pressure saturation temperature. 4) In case of keep 30 minutes in state that satisfy all above conditions (1, 2, 3).
Cause of problem	Compressor discharge or Top temperature sensor breakaway and defective / starting badness of compressor

1. Inspection Method

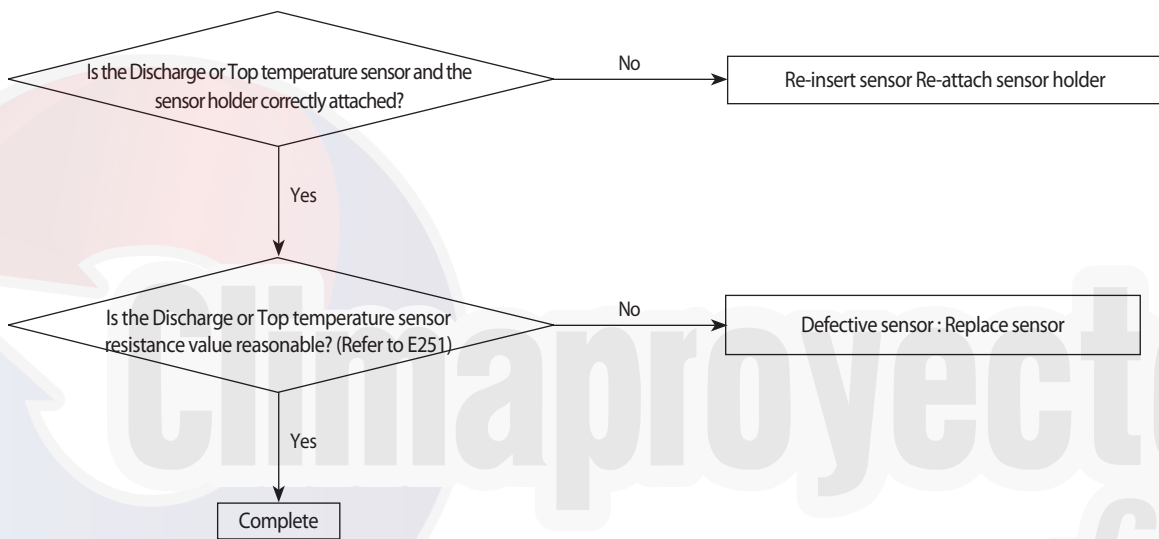

4-3-12. E269 : Suction temperature sensor breakaway error

Inverter / Hydro control part display	E269
Judgment Method	Difference of suction temperature of compressor starting verge and suction temperature that is on present operation : If less than 2°C(3.6°F) for 30 minutes to keep. (Judgment at heating operation only)
Cause of problem	Suction temperature sensor breakaway / defective.

1. Inspection Method

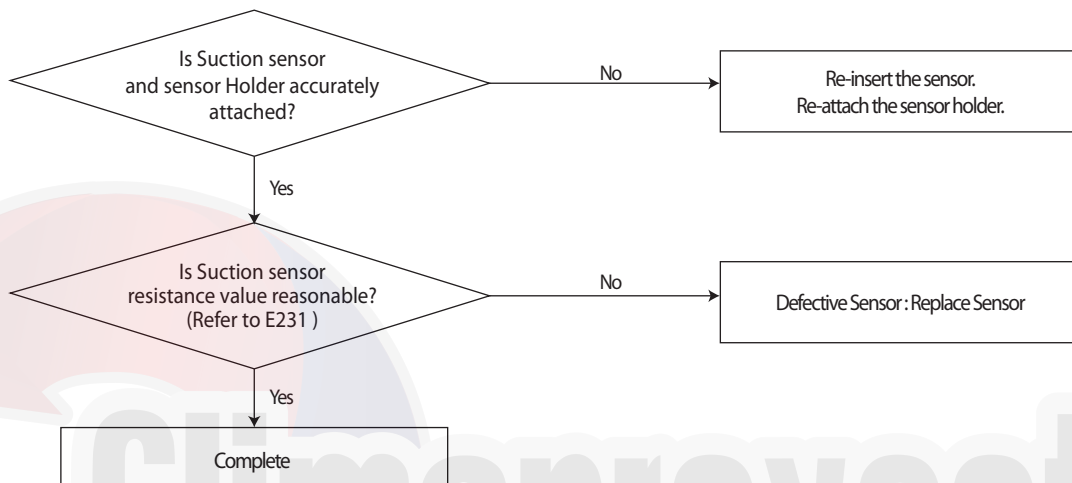

4-3-13. High pressure sensor error (Open / Short)

Inverter / Hydro control part display	<i>E291</i>
Judgment Method	Refer to the inspection method below.
Cause of problem	Disconnection or breakdown of relevant sensor.

- High Pressure sensor Open/Short error determination method
 - Identifies from when power is supplied or 2 minutes after RESET, and only when set is stopped.
 - An Open/Short error will occur if the input voltage standard range of 0.5V ~ 4.95V is exceeded.

2. Inspection Method

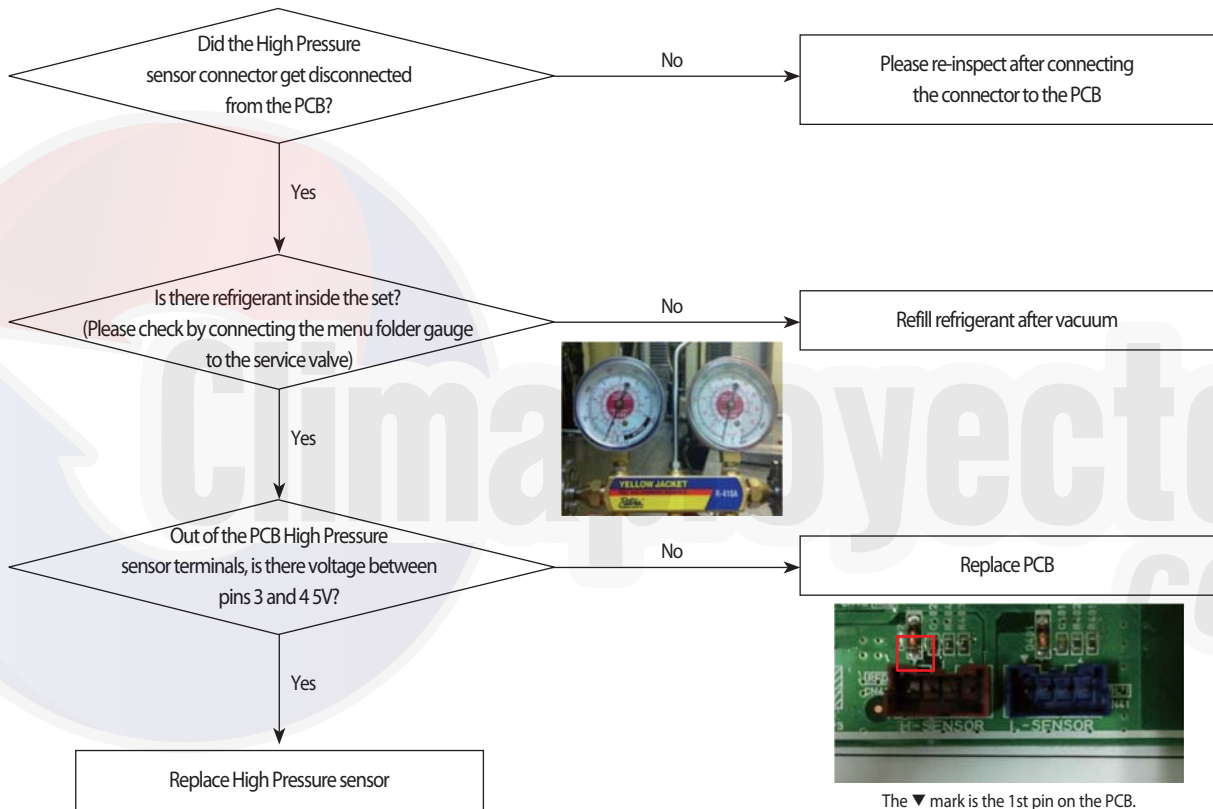

The ▼ mark is the 1st pin on the PCB.

4-3-14. Low pressure sensor error (Open / Short)

Inverter / Hydro control part display	E296
Judgment Method	Refer to the inspection method below.
Cause of problem	Disconnection or breakdown of relevant sensor.

1. Low Pressure sensor Open/Short error determination method
 - 1) Identifies from when power is supplied or 2 minutes after RESET, and only when set is stopped.
 - 2) An Open/Short error will occur if the input voltage standard range of 0.5V ~ 4.95V is exceeded.

2. Inspection Method

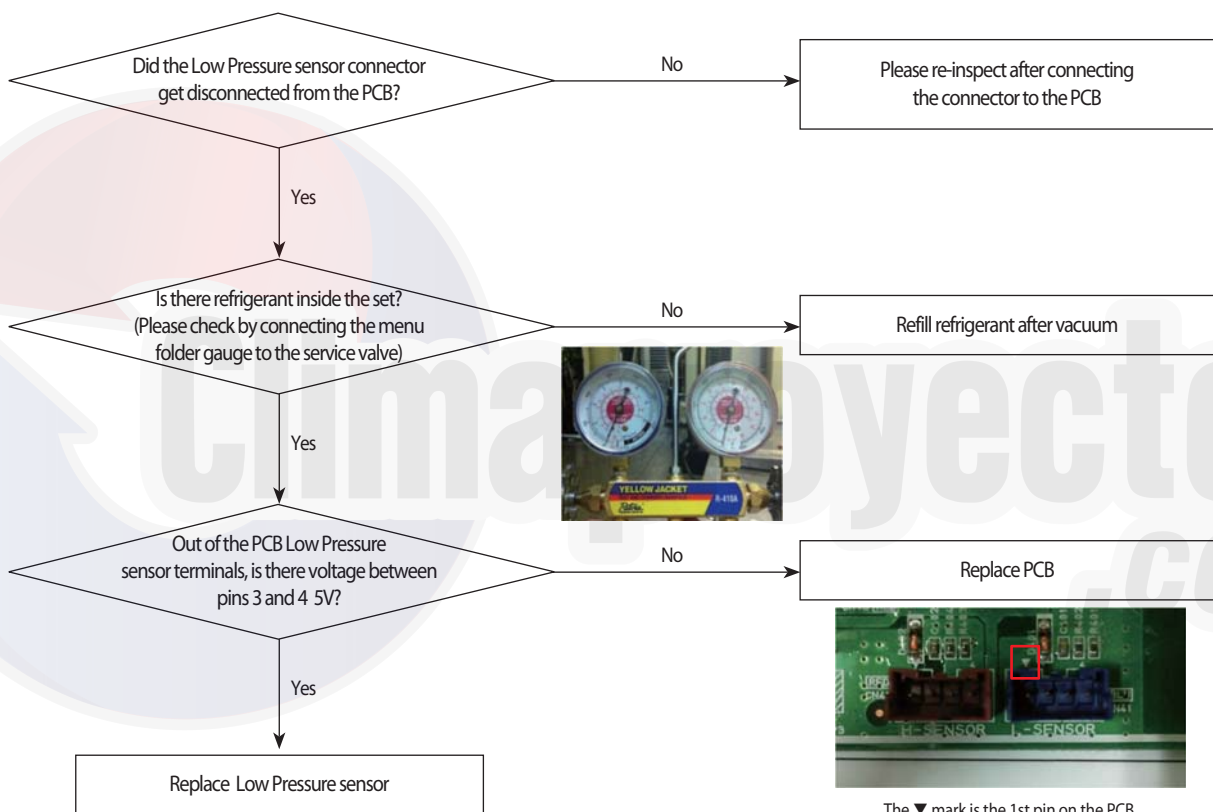

The ▼ mark is the 1st pin on the PCB.

4-3-15. Suction temperature sensor error (Open / Short)

Inverter / Hydro control part display	E308
Judgment Method	Refer to the inspection method below.
Cause of problem	Disconnection or breakdown of relevant sensor.

1. Inspection Method

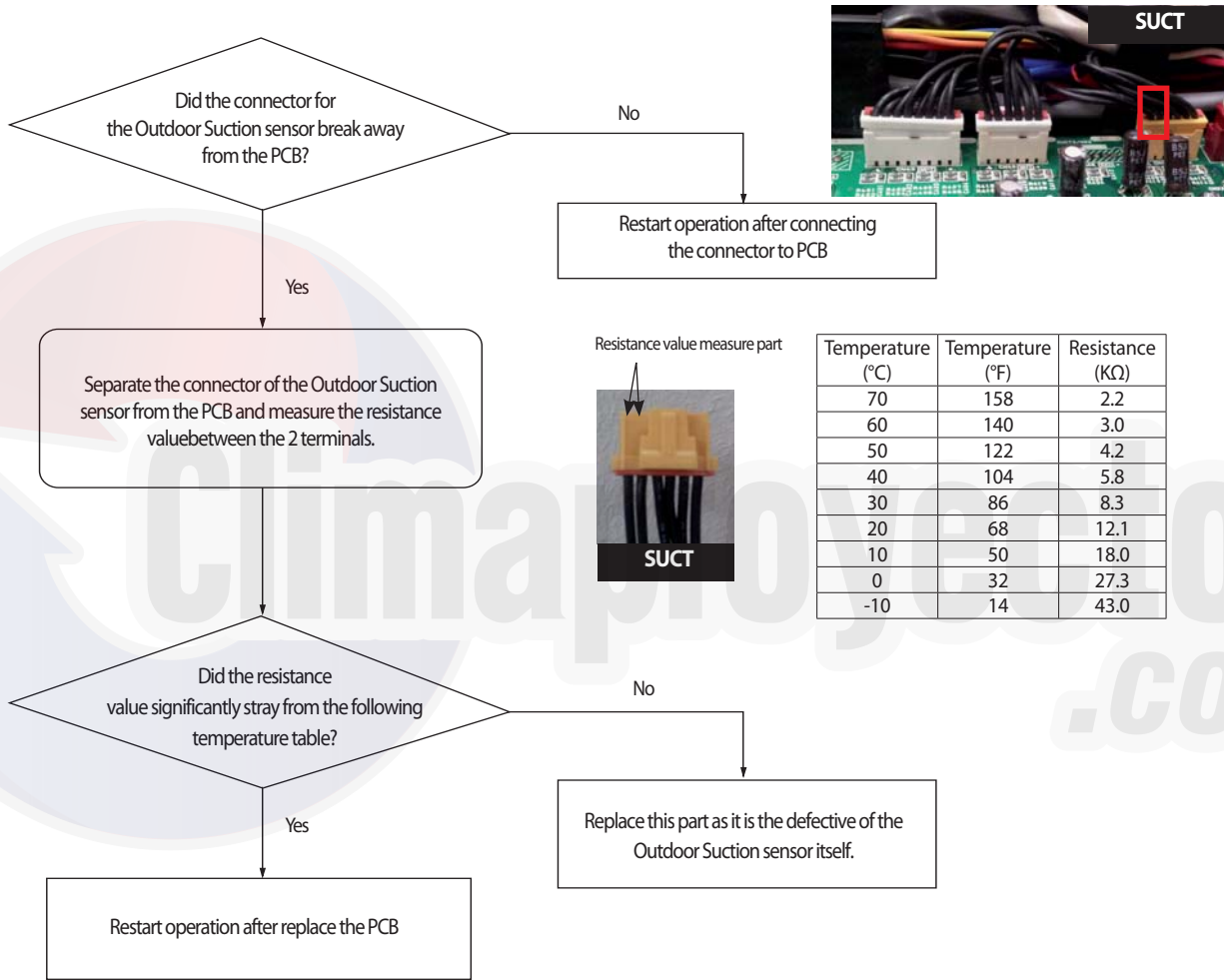

4-3-16. Liquid pipe temperature sensor error (Open / Short)

Inverter / Hydro control part display	E311
Judgment Method	Refer to the inspection method below.
Cause of problem	Disconnection or breakdown of relevant sensor.

1. Inspection Method

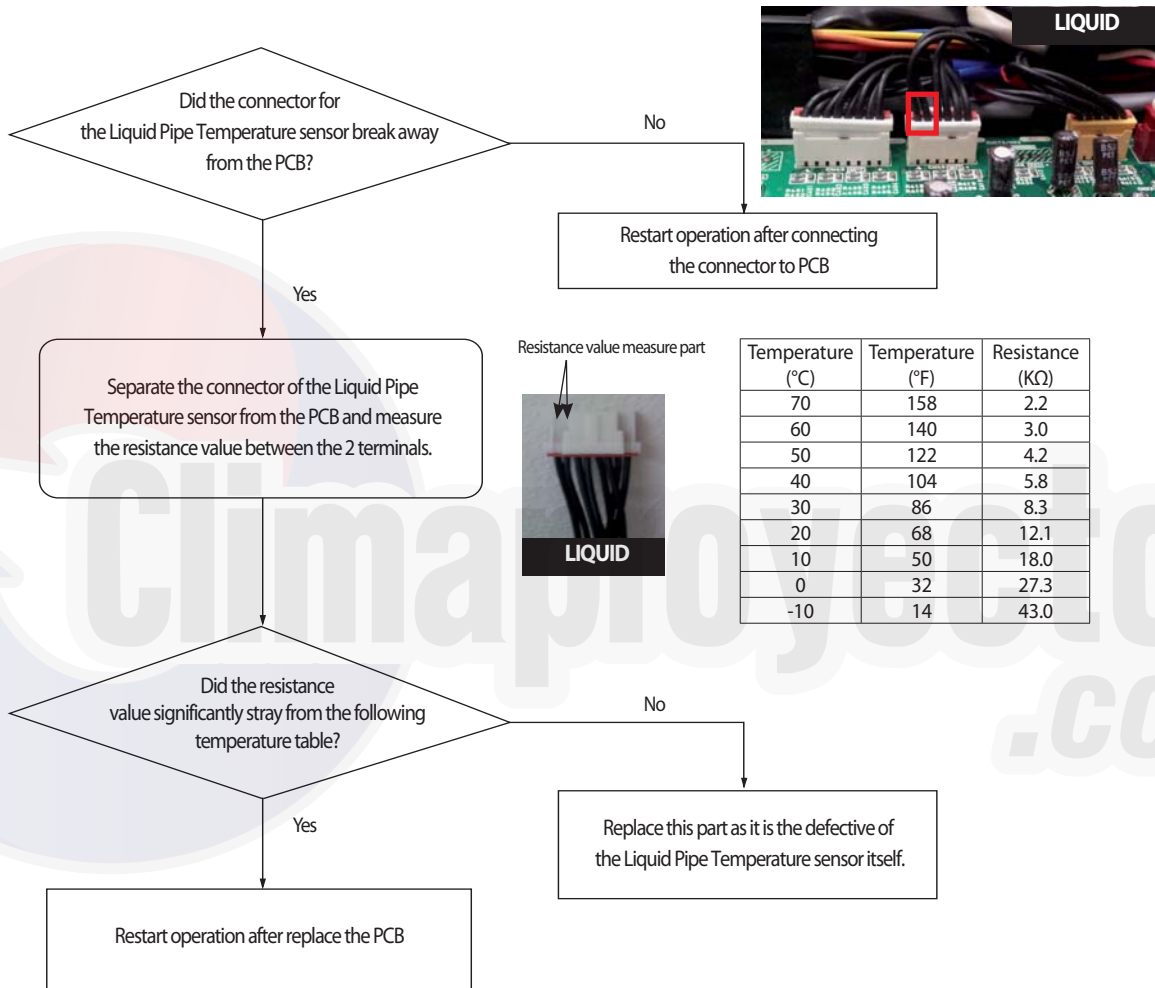

4-3-17. EVI IN temperature sensor error (Open / Short)

Inverter / Hydro control part display	E321
Judgment Method	Refer to the inspection method below.
Cause of problem	Disconnection or breakdown of relevant sensor.

1. Inspection Method

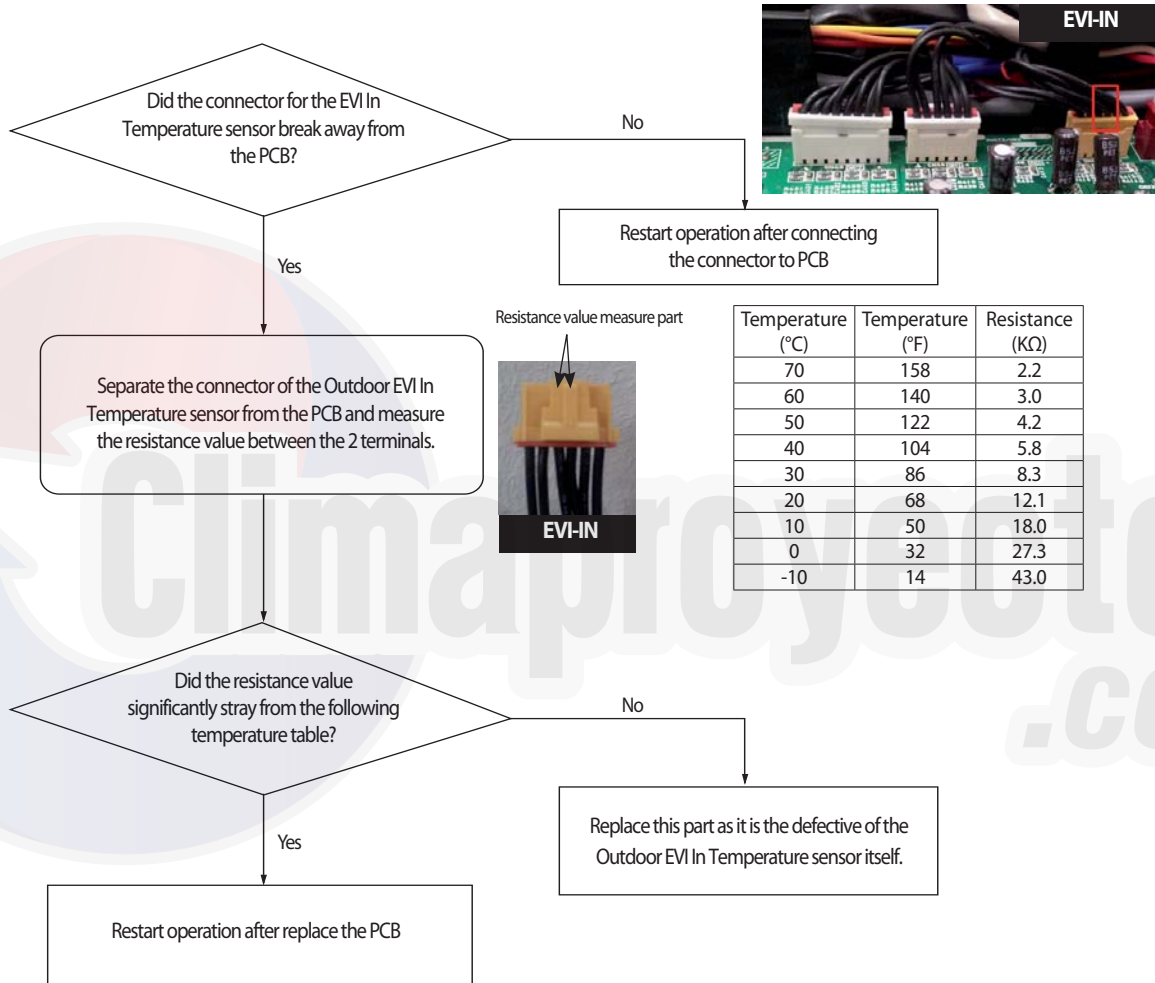

4-3-18. EVI OUT temperature sensor error (Open / Short)

Inverter / Hydro control part display	E322
Judgment Method	Refer to the inspection method below.
Cause of problem	Disconnection or breakdown of relevant sensor.

1. Inspection Method

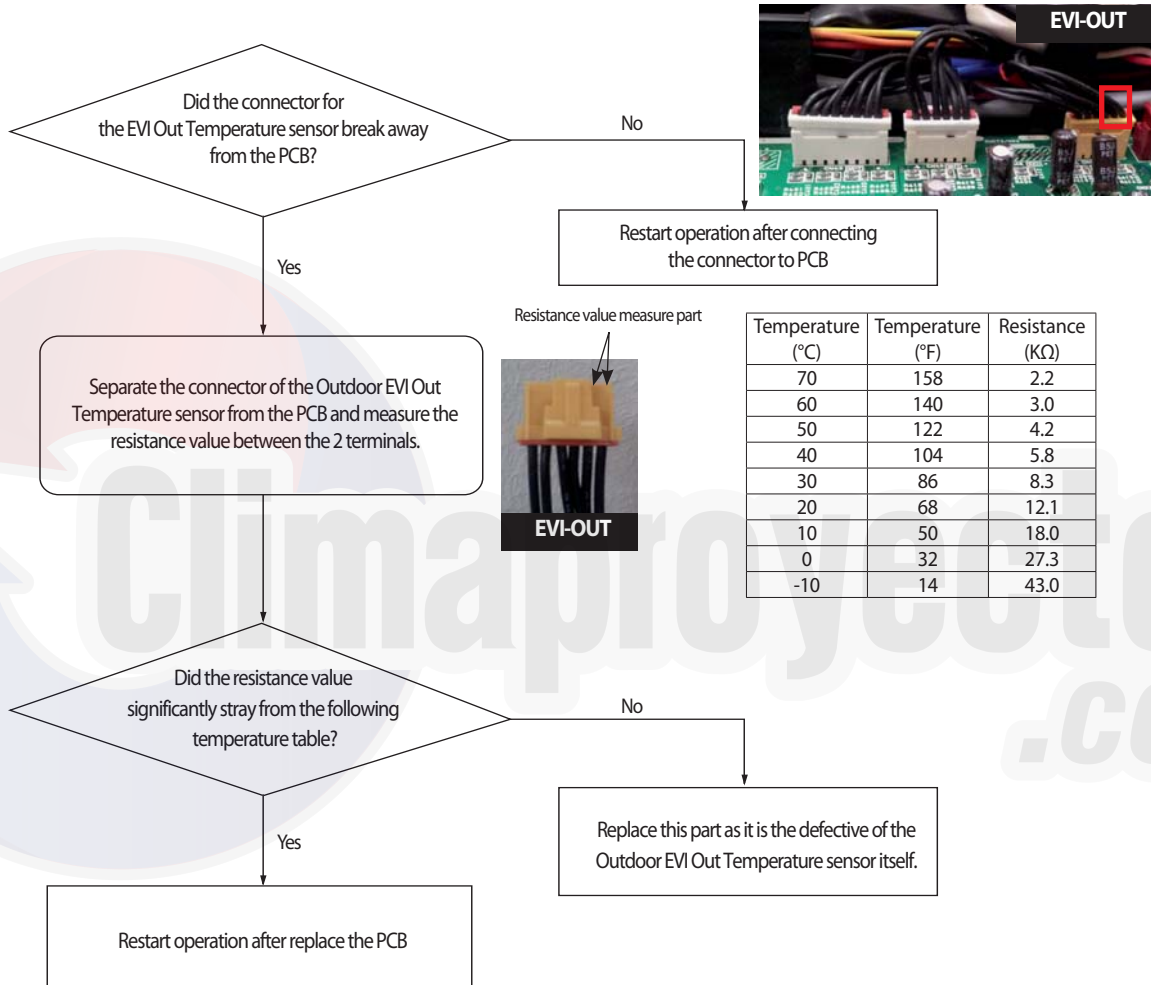

4-3-19. Suction-2 temperature sensor error (Open / Short)

Inverter / Hydro control part display	E323
Judgment Method	Refer to the inspection method below.
Cause of problem	Disconnection or breakdown of relevant sensor.

1. Inspection Method

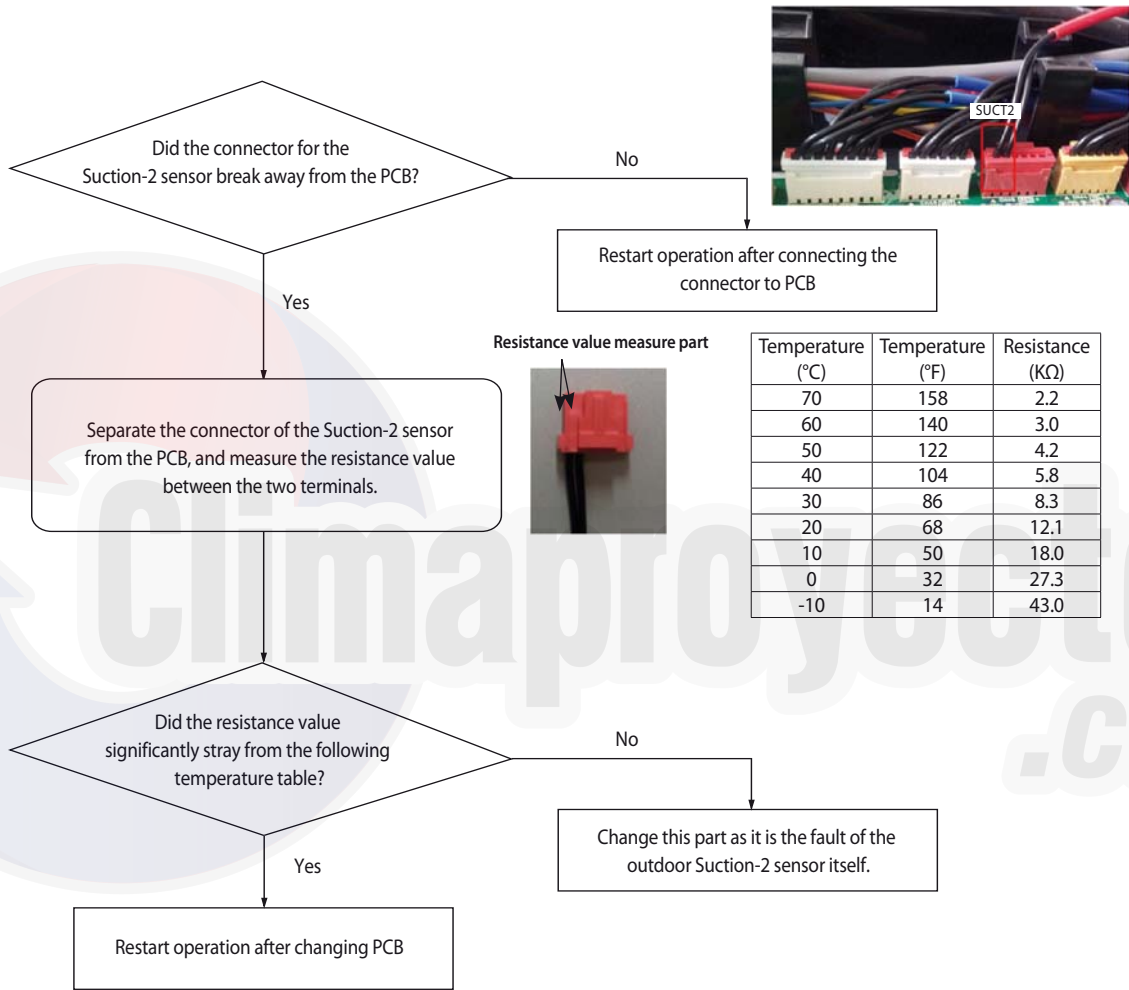

4-3-20. Measures of other outdoor unit error

Inverter / Hydro control part display	<i>E347</i>	FAN2 wire unconnected error	<i>E399</i>	FAN2 PBA IPM temperature sensor error
	<i>E447</i>	FAN1 wire unconnected error	<i>E499</i>	FAN1 PBA IPM temperature sensor error
	<i>E367</i>	COMP.2 wire unconnected error	<i>E374</i>	Inverter PBA2 IGBT temperature sensor error
	<i>E467</i>	COMP.1 wire unconnected error	<i>E474</i>	Inverter PBA1 IGBT temperature sensor error
Judgment Method	· Refer to the measures code below.			
Cause of problem	· Refer to the measures code below.			

1. Judgement by code

Code	Error	Measures
E347	FAN2 wire unconnected error	1. Check the FAN motor and PBA connection. 2. When connected Inverterr checker, if LED operates in the normality : External factors or when LED operates by abnormality, replace the FAN PBA.
E447	FAN1 wire unconnected error	1. Check the FAN motor and PBA connection. 2. When connected Inverterr checker, if LED operates in the normality : External factors or when LED operates by abnormality, replace the FAN PBA.
E367	COMP.2 wire unconnected error	1. Check the Compressor and Inverter PBA connection. 2. When connected inverter checker, if LED operates in the normality : External factors or when LED operates by abnormality, replace the Inverter PBA.
E467	COMP.1 wire unconnected error	1. Check the Compressor and Inverter PBA connection. 2. When connected inverter checker, if LED operates in the normality : External factors or when LED operates by abnormality, replace the Inverter PBA.
E399	FAN2 PBA IPM temperature sensor error	Replace FAN PBA
E499	FAN1 PBA IPM temperature sensor error	Replace FAN PBA
E374	Inverter PBA2 IGBT temperature sensor error	Replace Inverter PBA
E474	Inverter PBA1 IGBT temperature sensor error	Replace Inverter PBA

4-3-21. E407 : COMP DOWN due to high pressure protection control

Inverter / Hydro control part display	E407
Judgment Method	Value of the high pressure sensor is detected at 40kgf/cm ² (568.9 psi) or more.
Cause of problem	<p><Coolingoperation> Outdoor unit fan motor problem (constrained, defective) Motor driver defective or wire is cut Outdoor heat exchanger is contaminated. Excessive refrigerant</p> <p><Heatingoperation> Motor driver defective or wire is cut Excessive refrigerant</p>

1. Inspection Method

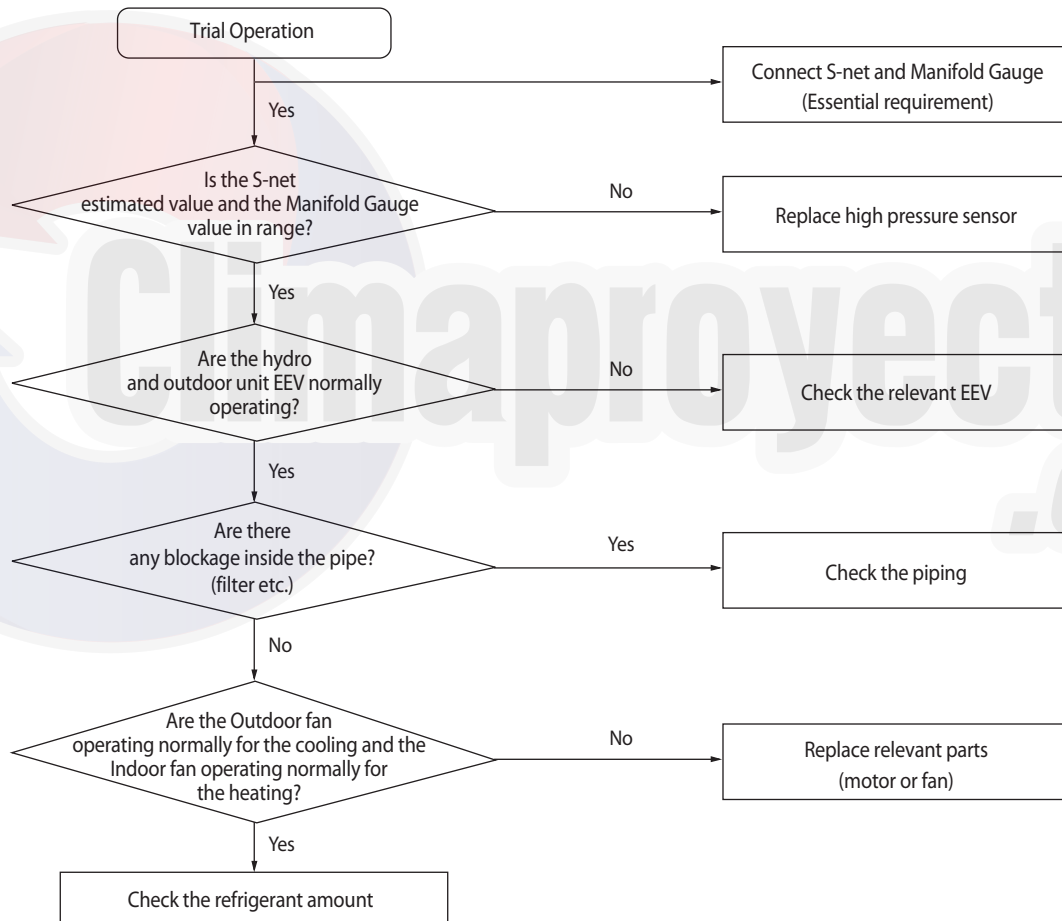

4-3-22. E4 10 : COMP DOWN due to low pressure protection control

Inverter / Hydro control part display	E4 10
Judgment Method	Inspection when the value of low pressure sensor is 1.8kg/cm ² (25.6 psi), or less for air conditioning and 0.8kg/cm ² (11.4 psi) for heating.
Cause of problem	<ul style="list-style-type: none"> · Refrigerant shortage · Electronic expansion valve blocked · Low pressure sensor defective · Leakage of compressor discharge check valve of not-go-end outdoor unit · Error may be found when used in temperature range outside the conditions of use (Operating outside temperature at -25°C (-13°F) or less for heating and operating outside temperature at -15°C (5°F) or less for Cooling)

1. Inspection Method

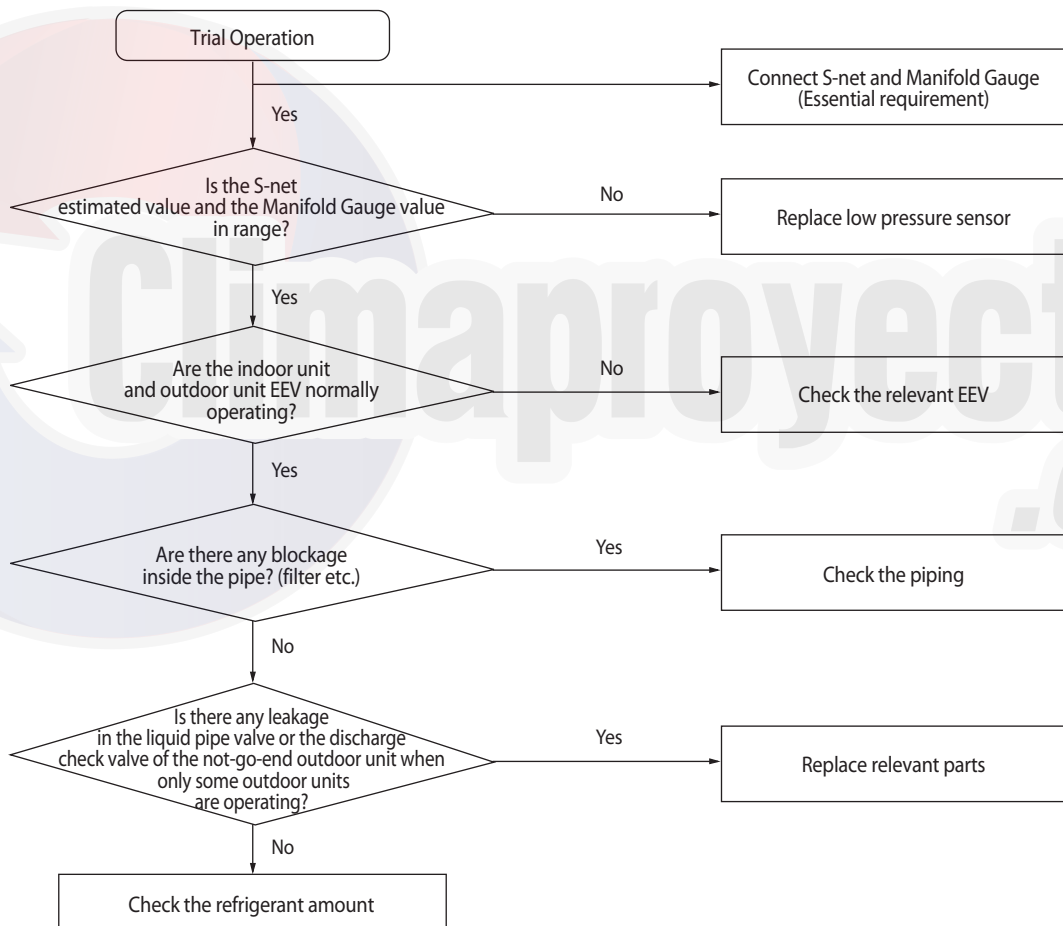

4-3-23. E4 16 : Suspension of starting due to compressor discharge temperature sensor / TOP temperature sensor

Inverter / Hydro control part display	E4 16
Judgment Method	When value of compressor discharge temperature sensor / TOP temperature sensor is checked at 120°C or more
Cause of problem	<ul style="list-style-type: none"> · Refrigerant shortage · Electronic expansion valve is blocked. · Defective discharge temperature sensor · TOP temperature sensor defective · Blocked pipe and defective · Leakage of compressor discharge check valve of not-go-end outdoor unit

1. Inspection Method

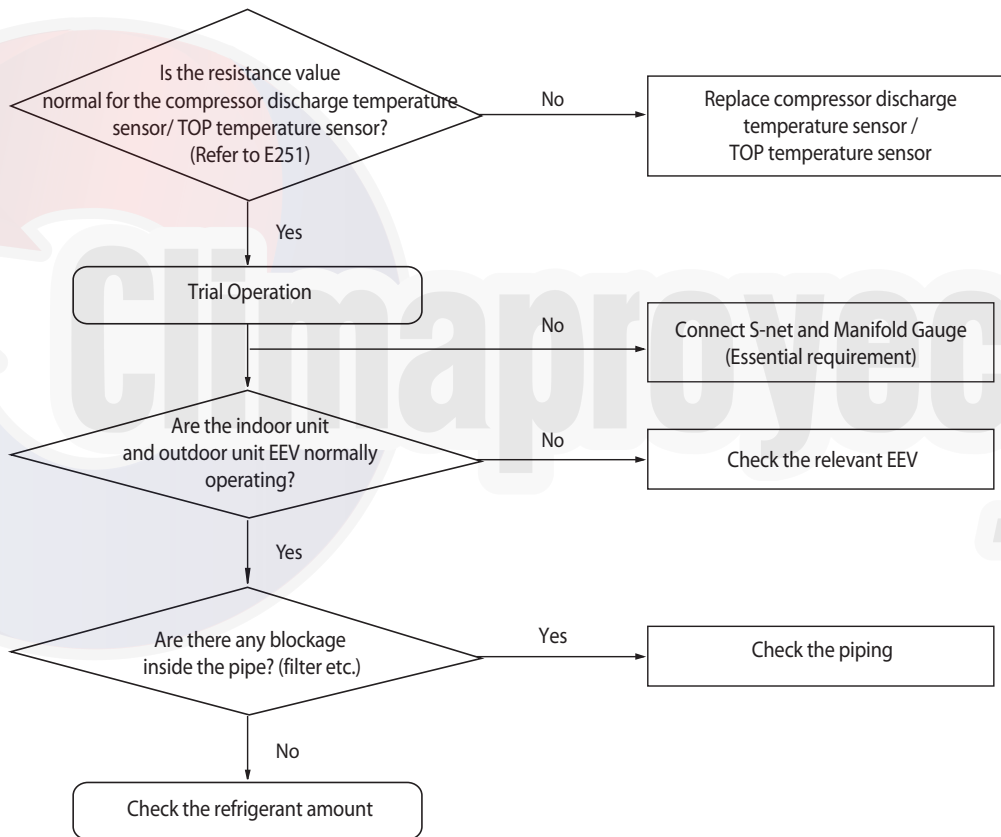

4-3-24. 3-phase Input Wiring error

Inverter / Hydro control part display	E425
Judgment Method	When turn on the power and check the status of the power from the inverter. If the phase does not connect the power(no phase) : E425 or E466 (E366) is displayed (Air conditioner to maintain the normal state.) However) N-phase must be properly connected.
Cause of problem	Check the input wiring EMI Fuse short-circuit

1. Inspection Method

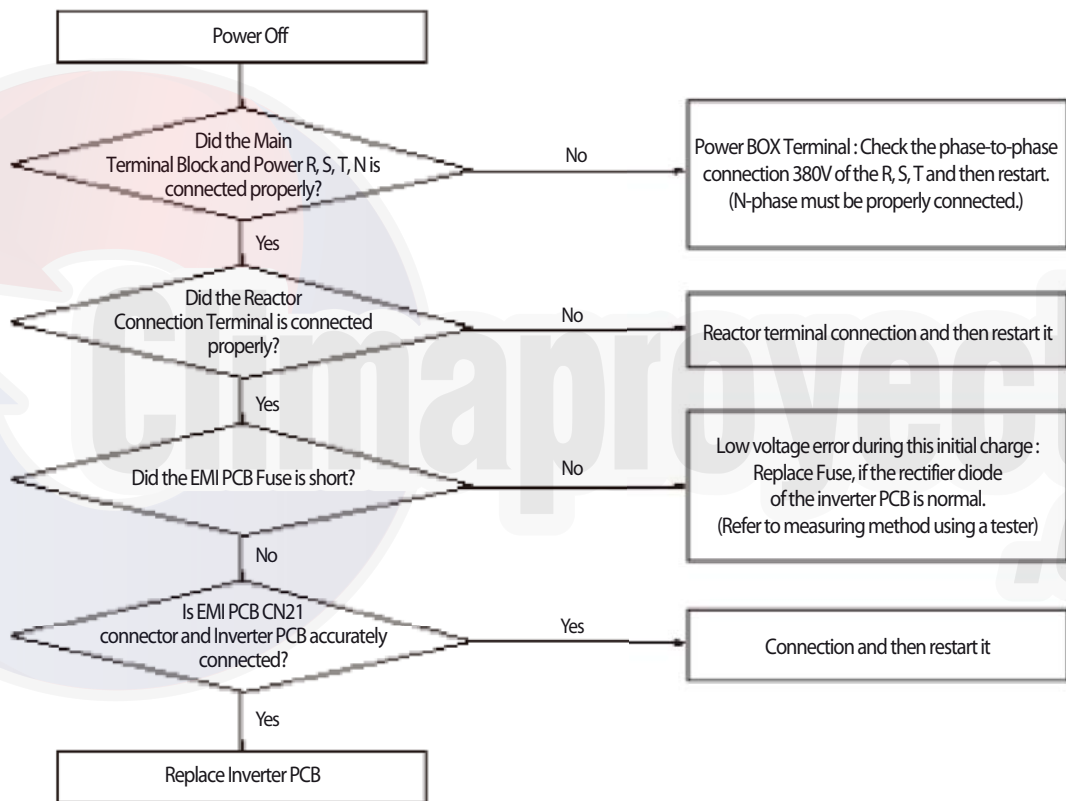

4-3-25. E428 : Suspension of starting by abnormal compression ratio

Inverter / Hydro control part display	E428
Judgment Method	<ul style="list-style-type: none"> · Compression ratio $[(\text{High pressure} + 1.03) / (\text{Low pressure} + 1.03)]$ less than 1.5 and lasts for 10 minutes or more · Differential pressure (high pressure - low pressure) less than 0.4 MPa.g and lasts for 10 minutes or more
Cause of problem	<ul style="list-style-type: none"> · Indoor and outdoor EEV breakdown · 4Way valve breakdown · High and low pressure sensor defective · Refrigerant shortage

1. Inspection Method

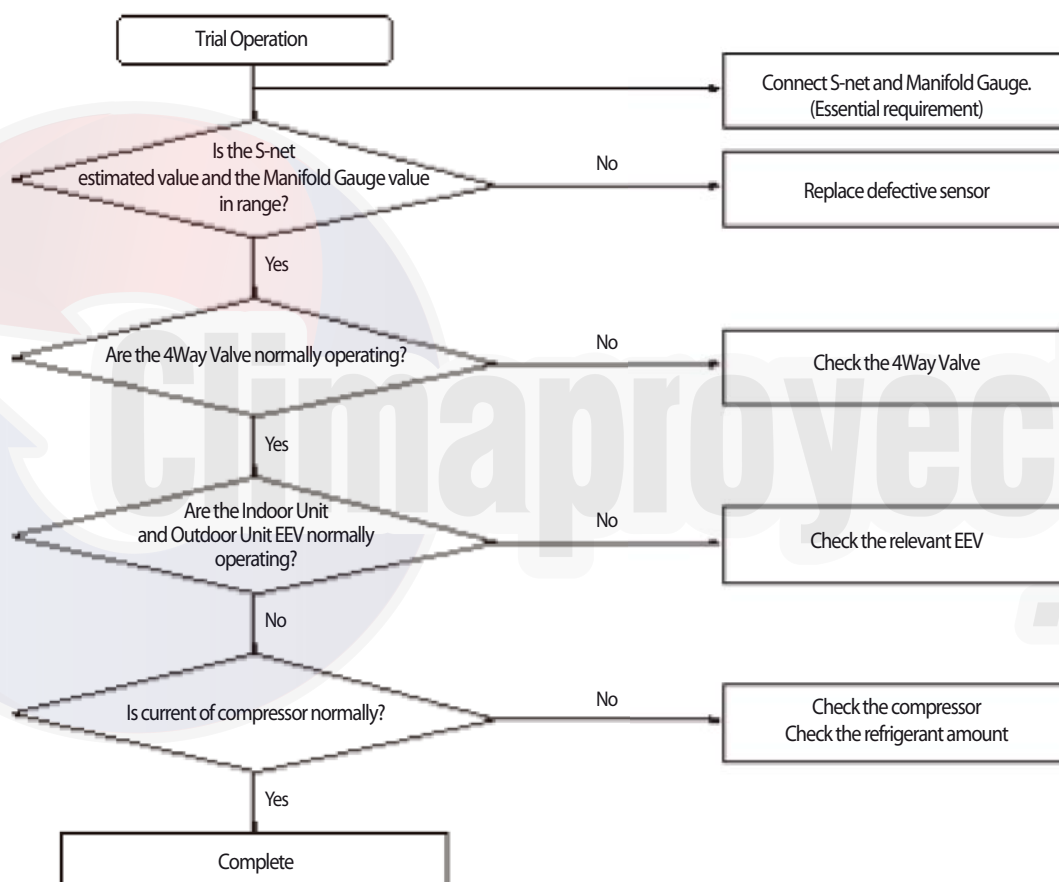

4-3-26. EVI EEV opening error

Inverter / Hydro control part display	E438
Judgment Method	· DSH < 10°C(50°F), EVI Out-in ≤ 0°C(32°F) & frequency > 65Hz 40 minutes maintaining.
Cause of problem	· EVI EEV and intercooler leakage, excessive refrigerant amount, outdoor check valve inserted opposite.

1. Inspection Method

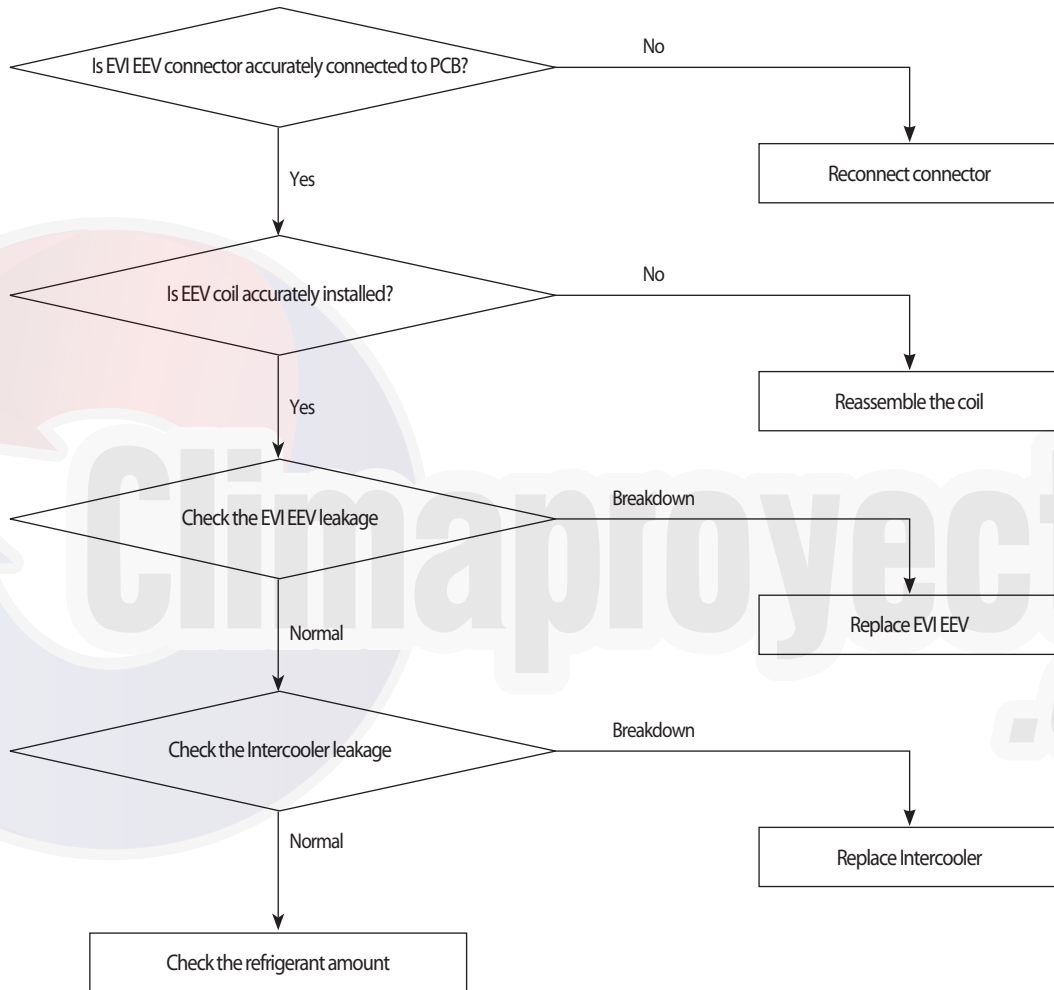

4-3-27 Refrigerant leakage error

Outdoor unit display	E439 (Refrigerant leakage judgment before starting) E443 (When start, refrigerant leakage judgment)
Judgment Method	<ul style="list-style-type: none"> · Before starting : Before compressor starting after system halt 2 minutes (High & low pressure sensor Open / Short error occurs and 1kgf/cm²(14.2psi) or less) · When start : When the high pressure sensor value(cooling 3.1kgf/cm²(44.1 psi), heating 2.2kgf/cm²(31.3psi)) is detection continuously for 3 seconds
Cause of problem	<ul style="list-style-type: none"> · Refrigerant leakage and shortage · Disconnection or breakdown of high & low pressure sensor

1. Pressure sensor Open/Short error determination method

- 1) Identifies from when power is supplied or 2 minutes after RESET, and only when set is stopped.
- 2) An Open/Short error will occur if the input voltage standard range of 0.5V ~ 4.95V is exceeded.

2. Inspection Method

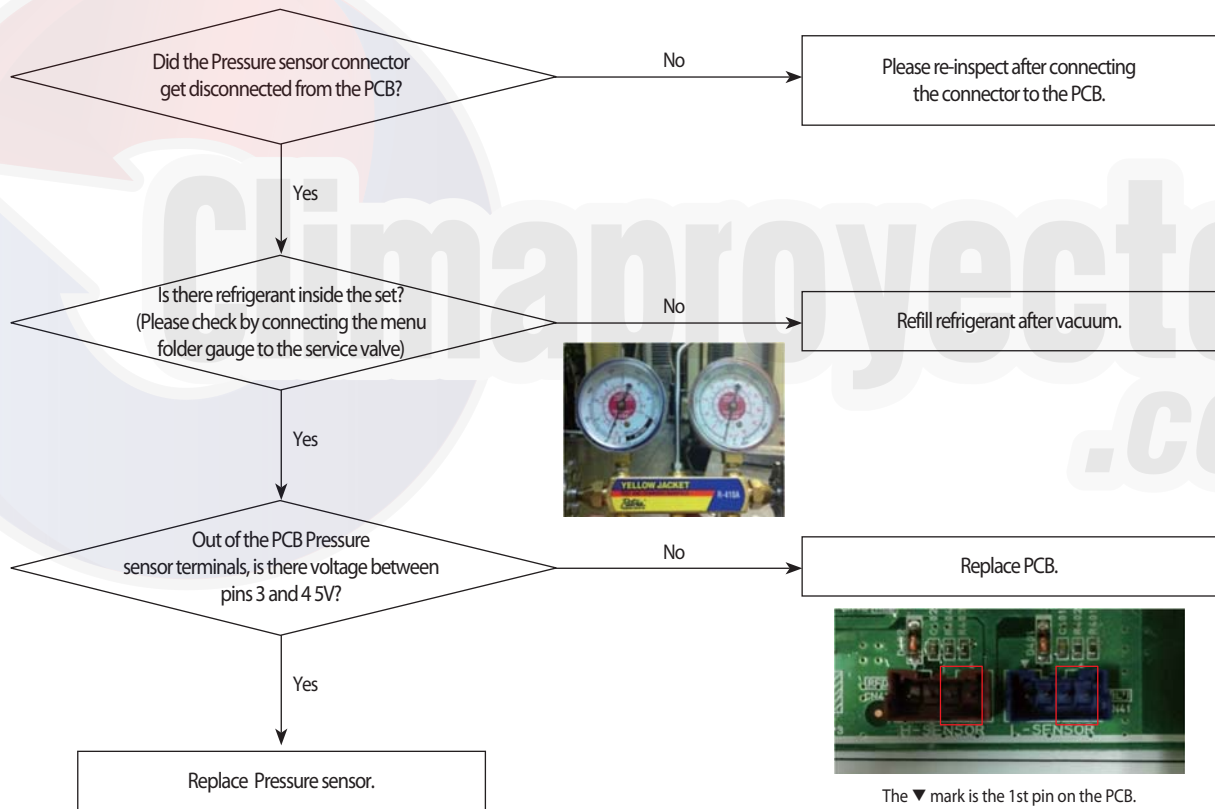

The ▼ mark is the 1st pin on the PCB.

4-3-28. Prevention of heating operation due to outdoor temperature

Inverter / Hydro control part display	E441 (Prevention of cooling operation due to low temperature of outdoor)
Judgment Method	· Cooling operation : When the outdoor temperature is less than -25°C (-13°F).
Cause of problem	· System protection operation status (Is not breakdown)



4-3-29 Fan starting error

Outdoor unit display	E446 (FAN PCB(FAN1)) E346 (FAN PCB(FAN2))
Judgment Method	<ul style="list-style-type: none"> · Startup, and then if the speed increase is not normally. · Detected by H/W or S/W
Cause of problem	<ul style="list-style-type: none"> · Compressor connection error · Defective Compressor · Defective PCB

1. Inspection Method

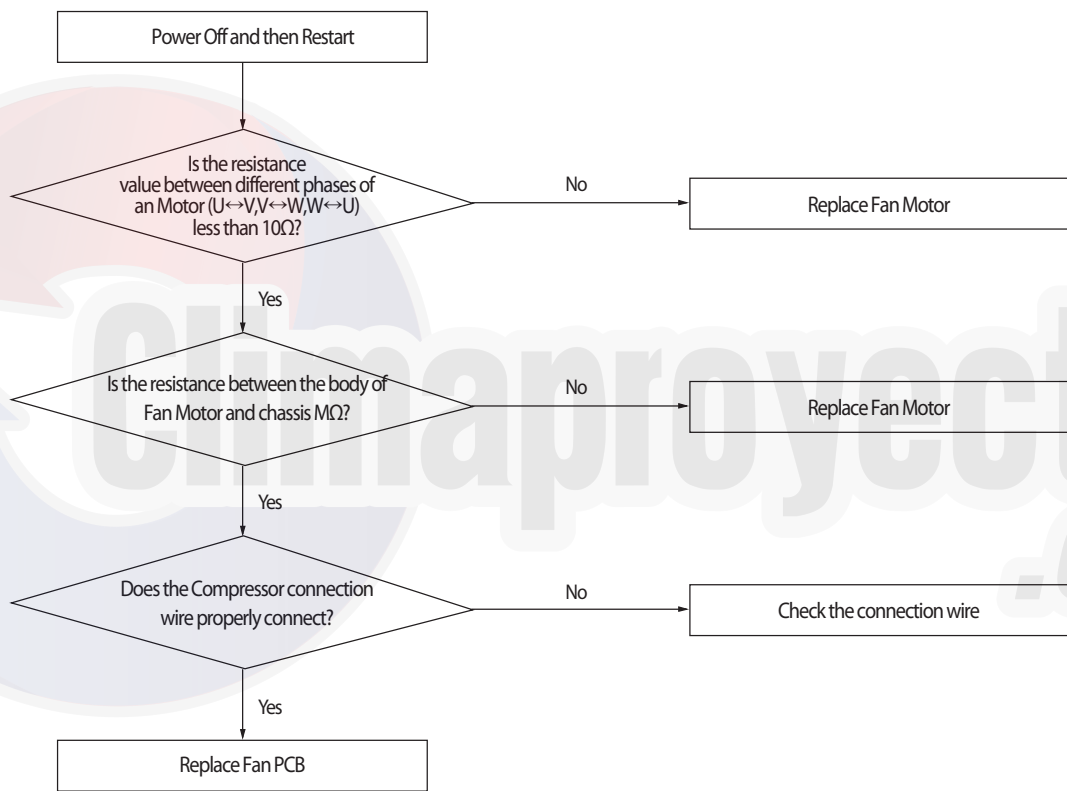

IPM breakdown diagnostics (FAN PCB)

1. Preparations before checking

- 1) Power Off
- 2) IPM failure, discharge mode may not work properly. Therefore, wait more than 15 minutes after the Power Off.
- 3) Remove all of the Fan PCB connectors. (Comp connector included)
- 4) Prepare the digital multi tester.

2. Inspection Method

- 1) Refer to Figure1 and Table1, respectively the resistance value and diode voltage value measure.
- 2) According to the criterion in Table 1 to determine whether the failure of IPM.

Division	Measured Point		Criterion	Remark
	+	-		
Measure the resistance values	40	U	More than 3MΩ	Measurement error can occur for reasons such as the initial measurement condenser discharge. Measured over at least three times.
	40	V		
	40	W		
	U	34		
	V	34		
Measure the diode voltage values	U	40	0.3~0.7V	
	V	40		
	W	40		
	34	U		
	34	V		
	34	W		

< Table 1 >

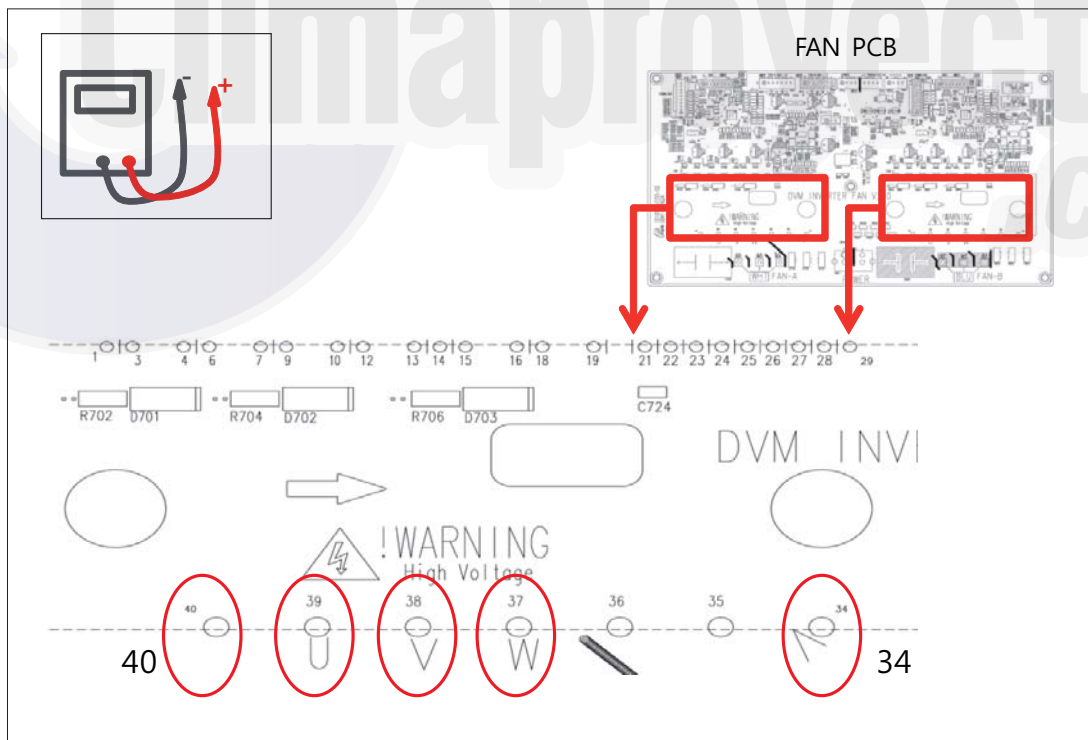

< Figure 1 >

4-3-30. Fan lock error

Inverter / Hydro control part display	E448 (FAN PCB(FAN1)) E348 (FAN PCB(FAN2))
Judgment Method	· Is checked symptoms by phase current of Fan Motor.
Cause of problem	· Fan Motor connection error. · Defective Fan · Defective PCB

1. Inspection Method

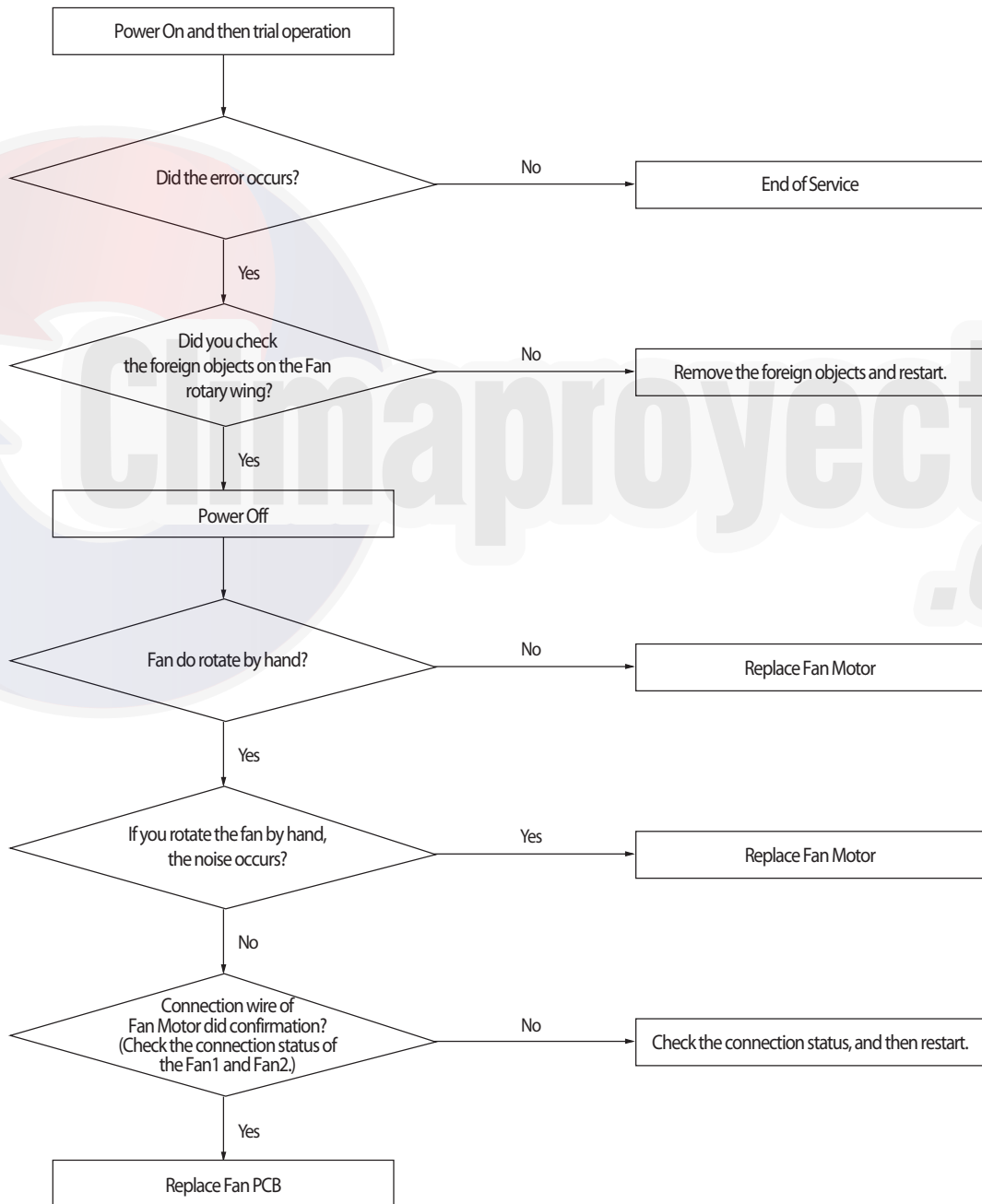

4-3-31. Momentary blackout error

Inverter / Hydro control part display	E452 (Prevention of heating operation due to high temperature of outdoor)
Judgment Method	· Momentary stop of compressor due to momentary blackout.
Cause of problem	· Momentary stop of compressor due to momentary blackout.

1. Measures : Replace Hub PCB or Main, Hub connection wire.



4-3-32. Outdoor Fan Motor overheating

Inverter / Hydro control part display	E453 (FAN PCB(FAN1)) E353 (FAN PCB(FAN2))
Judgment Method	· Overheating due to the internal sensor of the Fan Motor.
Cause of problem	· Defective connection wire · Defective Fan Motor · Defective PCB · Defective installation conditions

1. Inspection Method

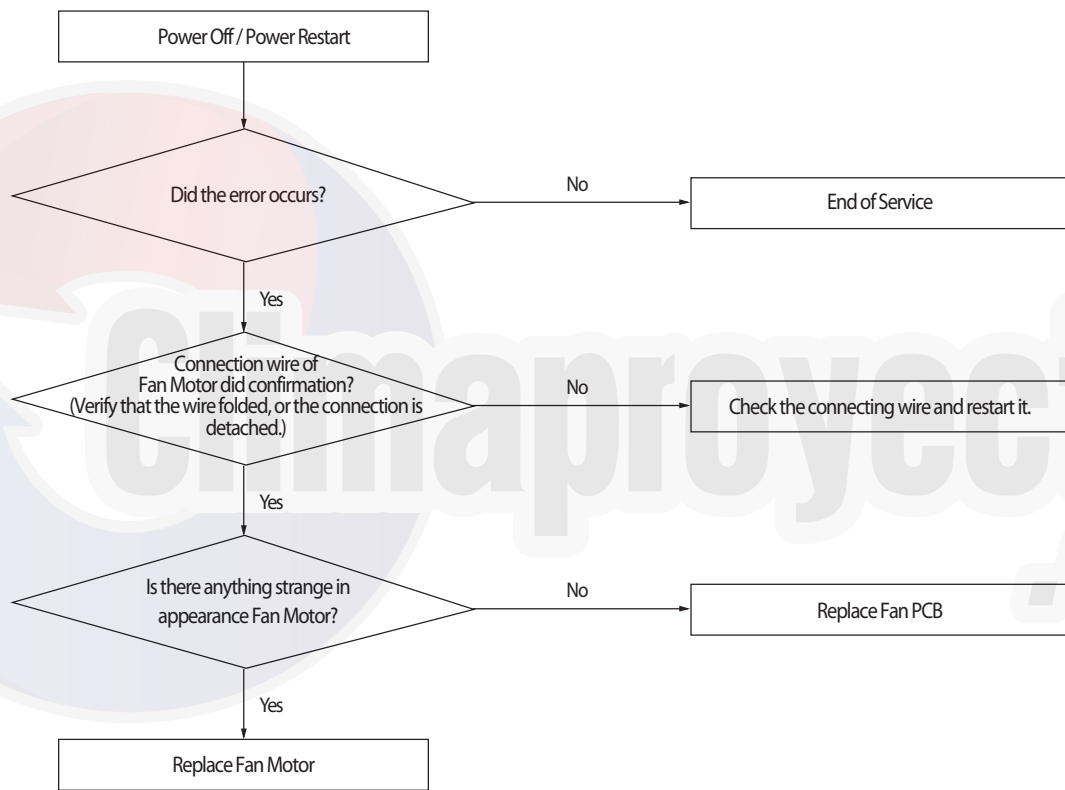

4-3-33. Fan IPM Overheat error

Inverter / Hydro control part display	E455 (FAN1 PCB) E355 (FAN2 PCB)
Judgment Method	· IPM internal temperature more than 85°C (E455, E355)
Cause of problem	· Heat sink and IPM assembly defective. · Defective heat sink cooling

1. Inspection Method

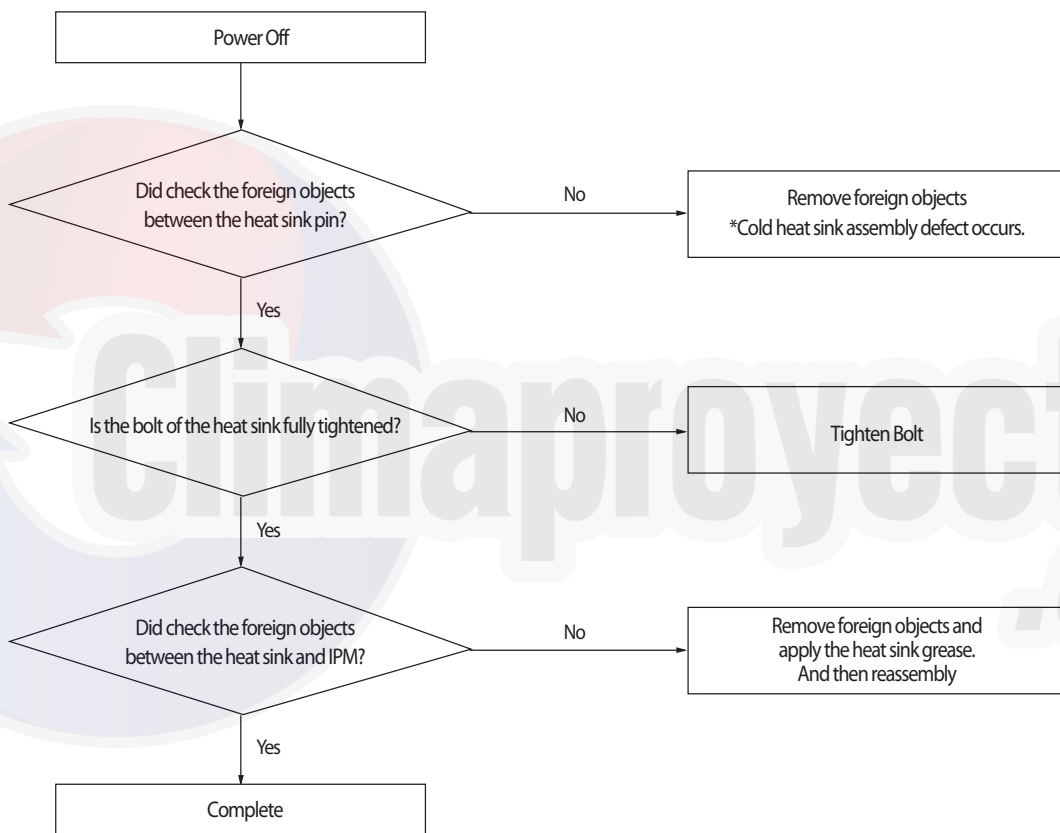

4-3-34. Compressor starting error

Inverter / Hydro control part display	E46 1 (INVERTER1 PCB) E36 1 (INVERTER2 PCB)
Judgment Method	<ul style="list-style-type: none"> · Startup, and then if the speed increase is not normally. · Detected by H/W or S/W.
Cause of problem	<ul style="list-style-type: none"> · Compressor connection error · Defective Compressor · Defective PCB

1. Inspection Method

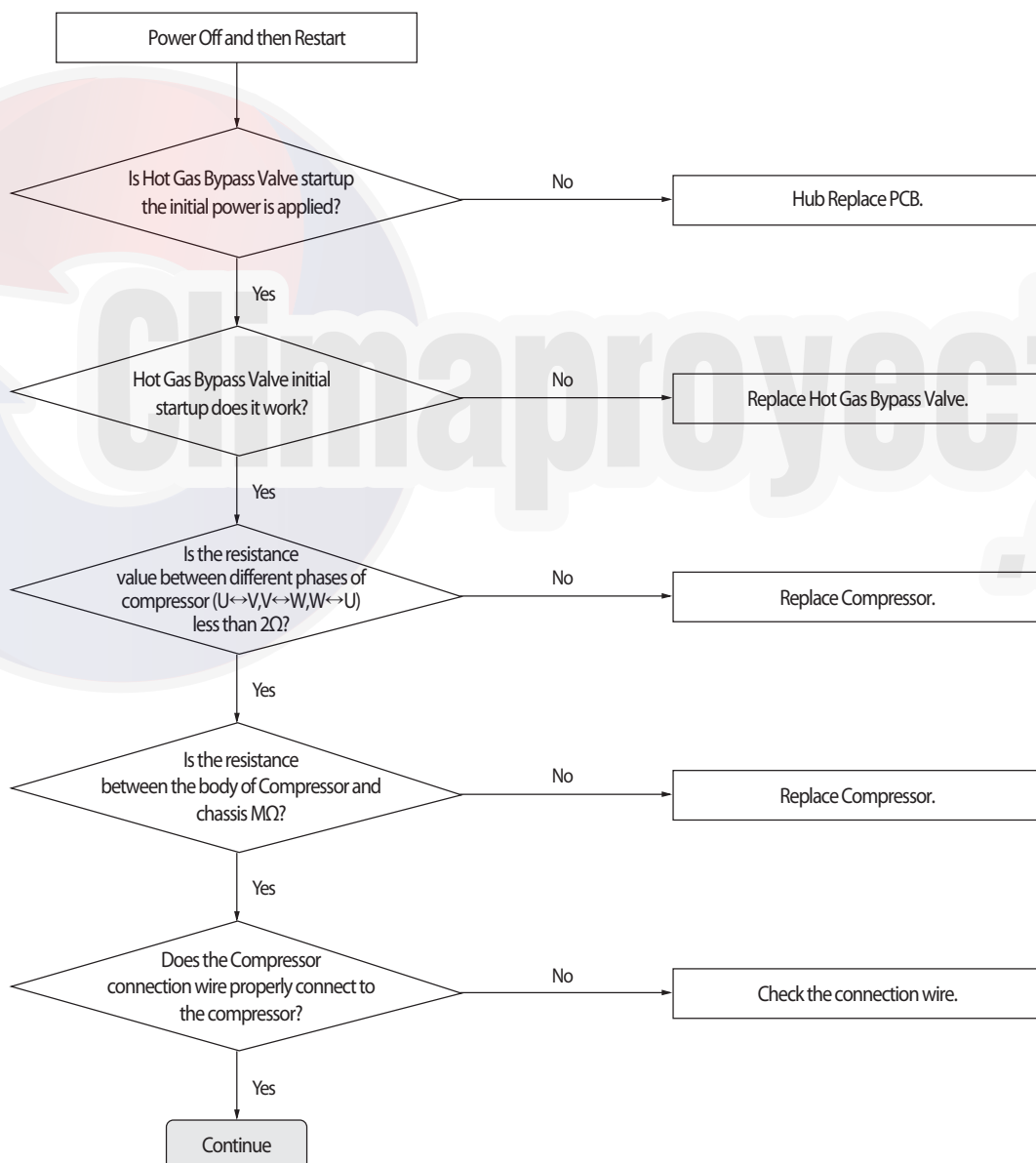

Starting error (cont.)

■ Compressor applied 2

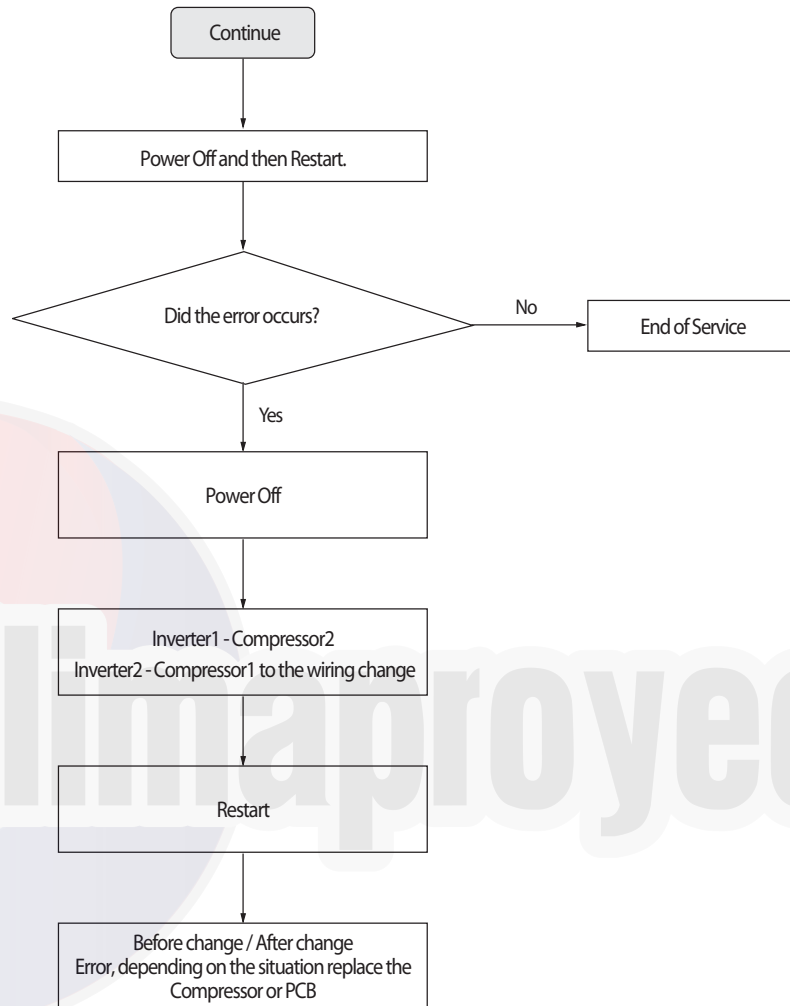

Before change	After change	Measure
Error of No.1 Compressor	Error of No.1 Compressor	Replace No.1 Compressor
Error of No.1 Compressor	Error of No.2 Compressor	Replace No.1 Inverter PCB
Error of No.2 Compressor	Error of No.2 Compressor	Replace No.2 Compressor
Error of No.2 Compressor	Error of No.1 Compressor	Replace No.2 Inverter PCB

4-3-35. Inverter Overcurrent error

Inverter / Hydro control part display	<i>E464/E465</i> (INVERTER1 PCB) <i>E364/E365</i> (INVERTER2 PCB)	
Judgment Method	<ul style="list-style-type: none"> · Will occur if the overcurrent flowing in the IPM. · Detected by H/W or S/W 	
Cause of problem	<ul style="list-style-type: none"> · Installation defective · Comp. defective · PCB defective 	<ul style="list-style-type: none"> · Connection wire error · Motor defective

1. Inspection Method

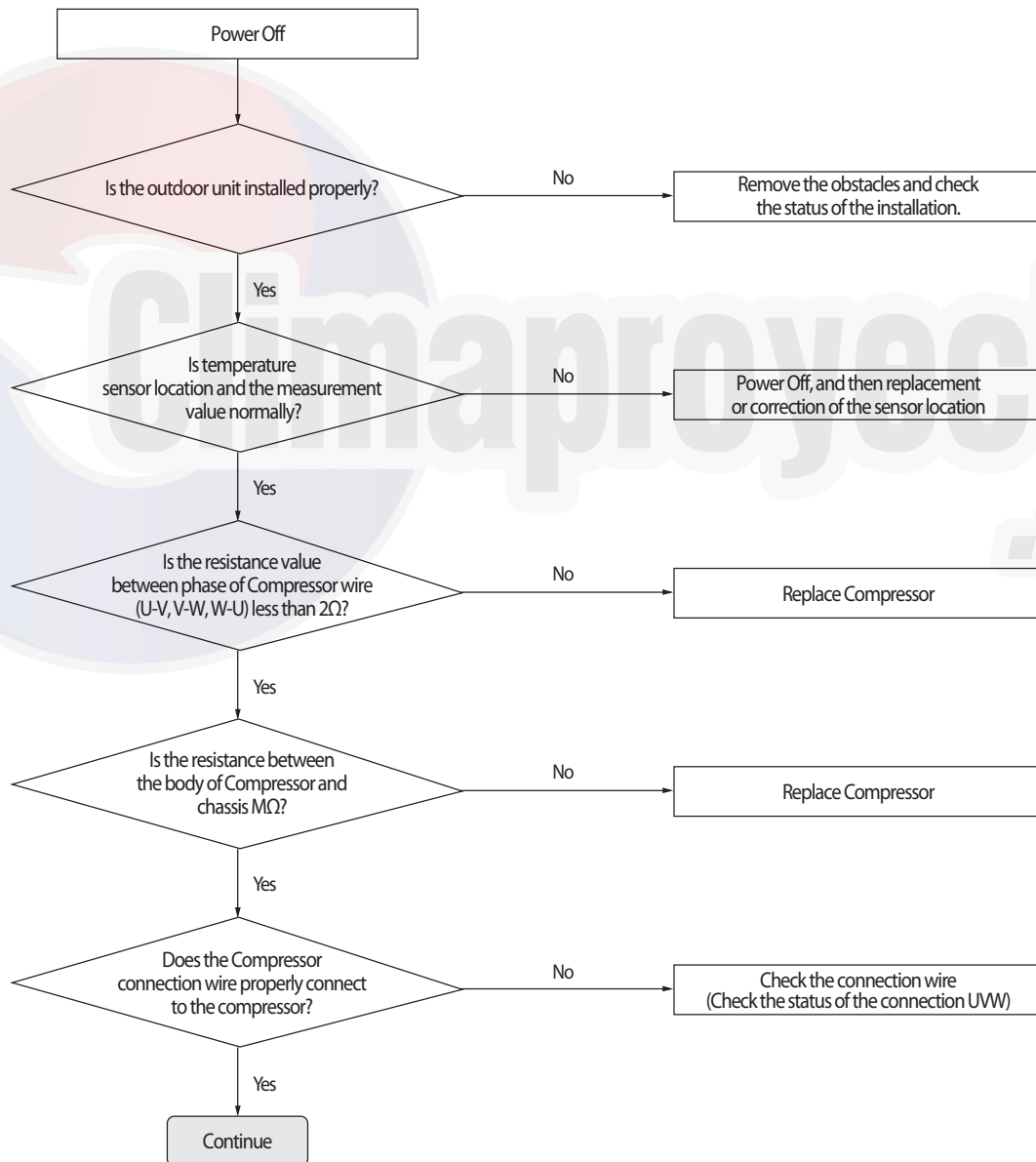

Compressor applied 2

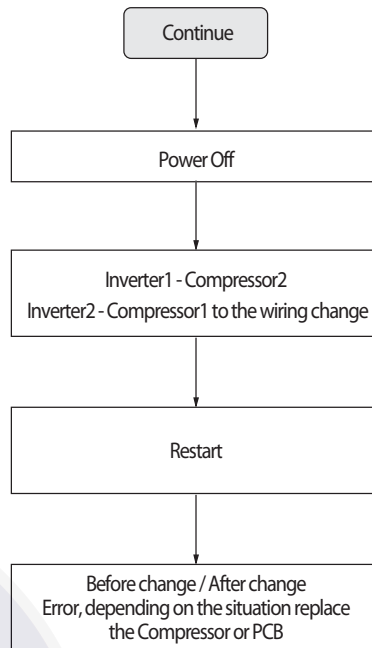

Before change	After change	Measure
Error of No.1 Compressor	Error of No.1 Compressor	Replace No.1 Compressor
Error of No.1 Compressor	Error of No.2 Compressor	Replace No.1 Inverter PCB
Error of No.2 Compressor	Error of No.2 Compressor	Replace No.2 Compressor
Error of No.2 Compressor	Error of No.1 Compressor	Replace No.2 Inverter PCB

IPM [IGBT] breakdown diagnostics (Inverter PCB)

1. Preparations before checking

- 1) Power Off.
- 2) IPM failure, discharge mode may not work properly. Therefore, wait more than 15 minutes after the Power Off.
- 3) Remove all of the Inverter PCB connectors and wire that is fixed as screw.
(Include wire that is fixed to compressor and DC Reactor.)
- 4) Prepare the digital multi tester.

2. Inspection Method

- 1) Refer to Figure1 and Table1, respectively the resistance value and diode voltage value measure.
- 2) According to the criterion in Table 1 to determine whether the failure of IPM.

Division	Measured Point		Criterion	Remark
	+	-		
Measure the resistance values	P-IGBT	U	More than 3MΩ	Measurement error can occur for reasons such as the initial measurement condenser discharge. Measured over at least three times.
	P-IGBT	V		
	P-IGBT	W		
	U	N-IGBT		
	V	N-IGBT		
	W	N-IGBT		
Measure the diode voltage values	U	P-IGBT	0.3~0.7V	
	V	P-IGBT		
	W	P-IGBT		
	N-IGBT	U		
	N-IGBT	V		
	N-IGBT	W		

< Table 1 >

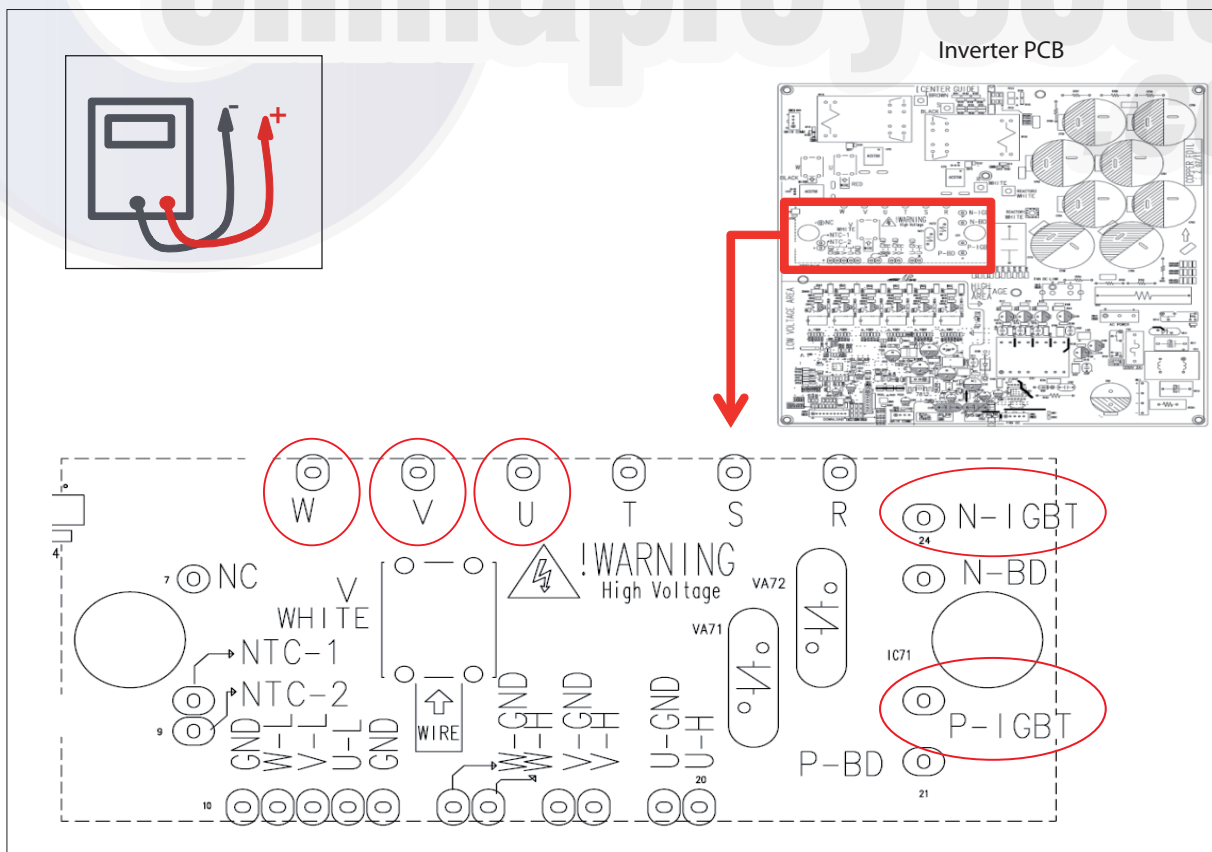

< Figure 1 >

4-3-36. Overvoltage / Low voltage error

Inverter / Hydro control part display	<i>E466</i> (INVERTER1 PCB) <i>E366</i> (INVERTER2 PCB)
Judgment Method	<ul style="list-style-type: none"> · N-phase wiring error and EMI Fuse short. · DC-Link Overvoltage / Low voltage occurs.
Cause of problem	<ul style="list-style-type: none"> · Check the input wiring · EMI Fuse short

1. Inspection Method

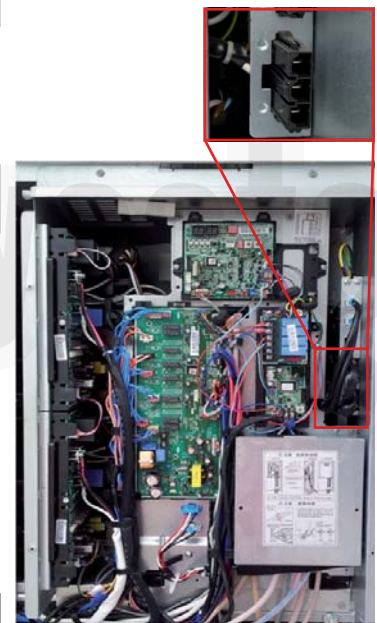
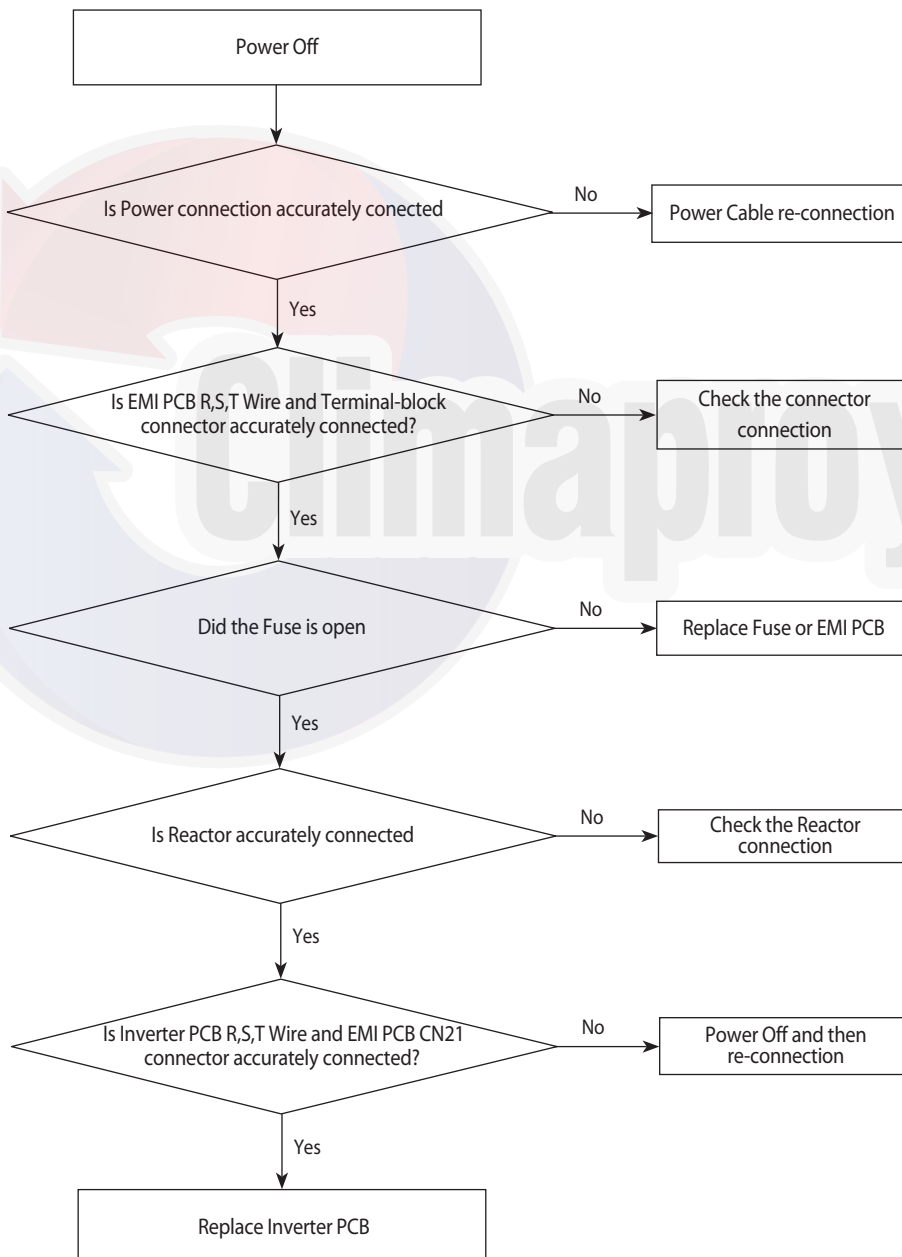

EMI PCB R,S,T Wire and Terminal-block connector

4-3-37. DC Link voltage sensor error

Outdoor unit display	E469 (INVERTER1 PCB) E369 (INVERTER2 PCB) E496 (OUTDOOR FAN 1 PCB)
Judgment Method	· DC voltage detection : Error judgment where the voltage value is more than 4.8V or less than 0.2V.
Cause of problem	· DC Link Connector disconnected · PCB voltage sensing circuit defective

1. Inspection Method

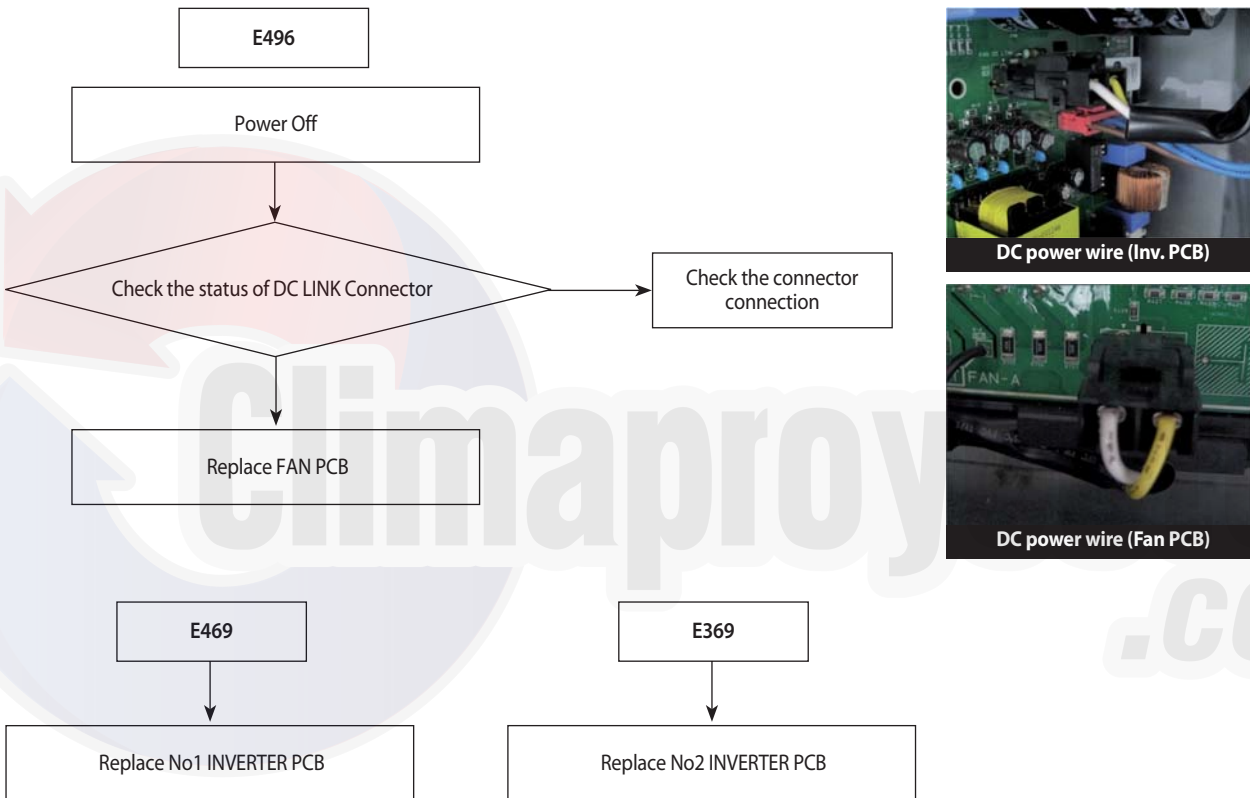

4-3-38. Fan Motor Overcurrent error

Outdoor unit display	E478/E489 (FAN PCB(FAN1)) E378/E389 (FAN PCB(FAN2))
Judgment Method	<ul style="list-style-type: none"> · Occurs when overcurrent flows in the IPM. · Detected by H/W or S/W
Cause of problem	<ul style="list-style-type: none"> · Defective FAN PCB · Connector error · Defective Motor

1. Inspection Method

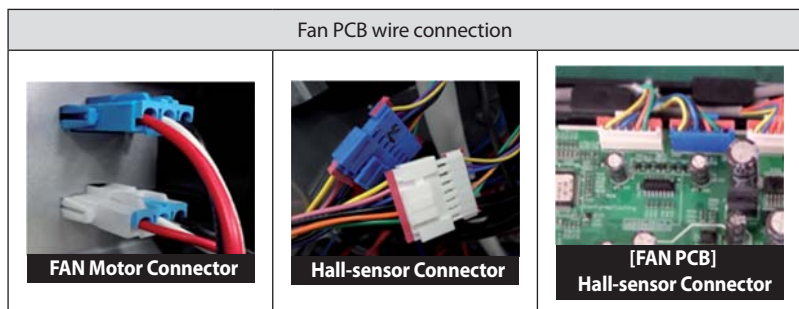
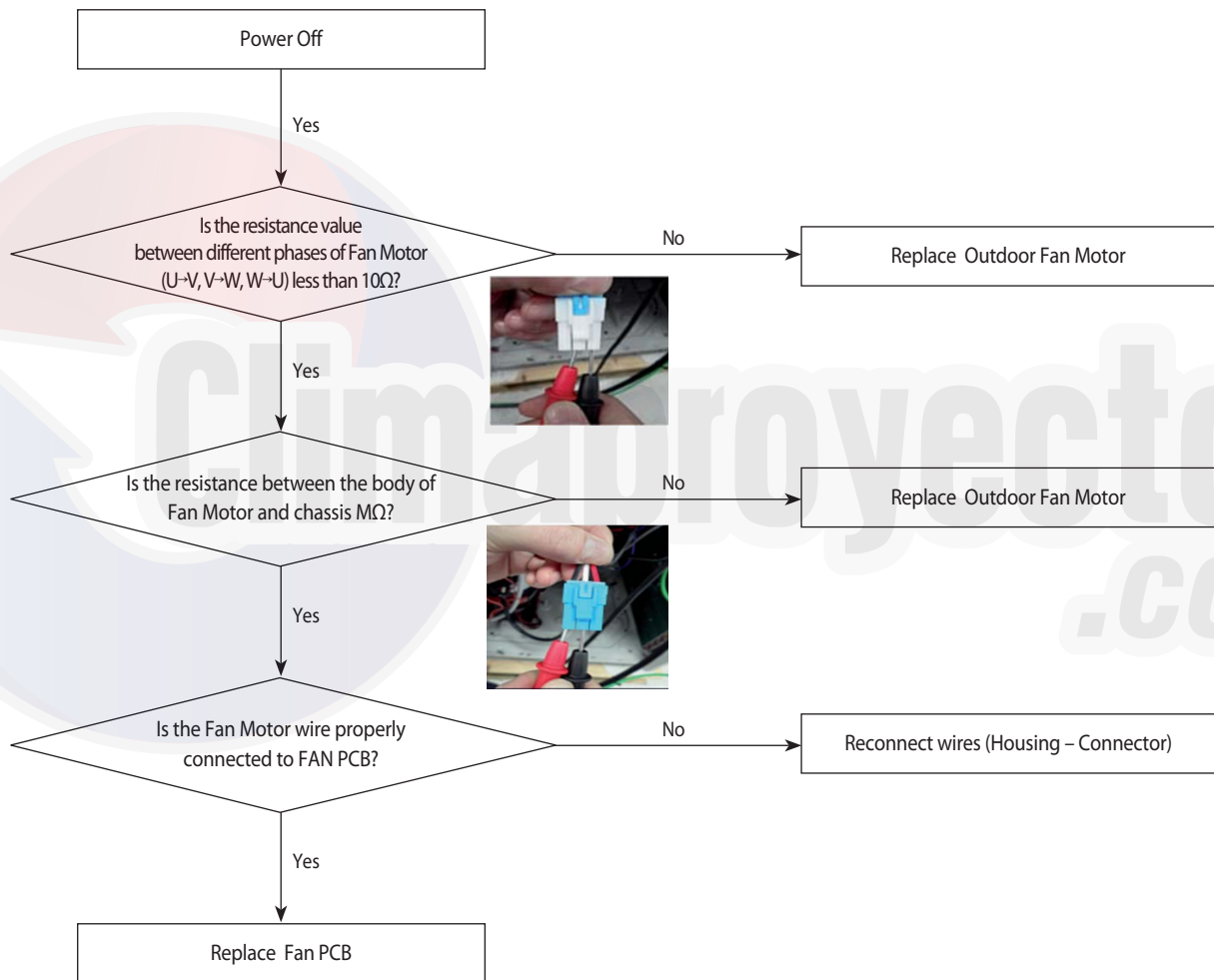

Fan Motor Overcurrent error (cont.)

Outdoor unit display	E489 (FAN PCB(FAN1)) E389 (FAN PCB(FAN2))
Judgment Method	<ul style="list-style-type: none"> · Occurs when overcurrent flows in the IPM. · Detected by H/W or S/W
Cause of problem	· Defective FAN Motor

1. Inspection Method

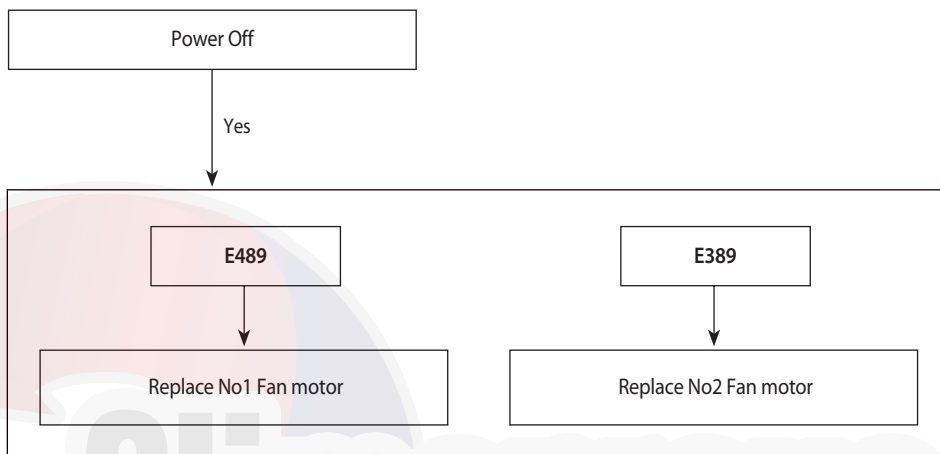

4-3-39. Input / Output Current sensor error

Outdoor unit display	<i>E485</i> INVERTER1 PCB(Input Current sensor) <i>E385</i> INVERTER2 PCB(Input Current sensor) <i>E468</i> INVERTER1 PCB(Output Current sensor) <i>E368</i> INVERTER 2 PCB(Output Current sensor) <i>E493</i> OUTDOOR FAN PCB (FAN1 Output Current sensor) <i>E393</i> OUTDOOR FAN PCB (FAN2 Output Current sensor)
Judgment Method	· Sensor Output detection : Judged as an error if the detected value is More than 4.5V or less than 0.5V
Cause of problem	· Input voltage defective · PCB voltage sensing circuit defective

1. Inspection Method

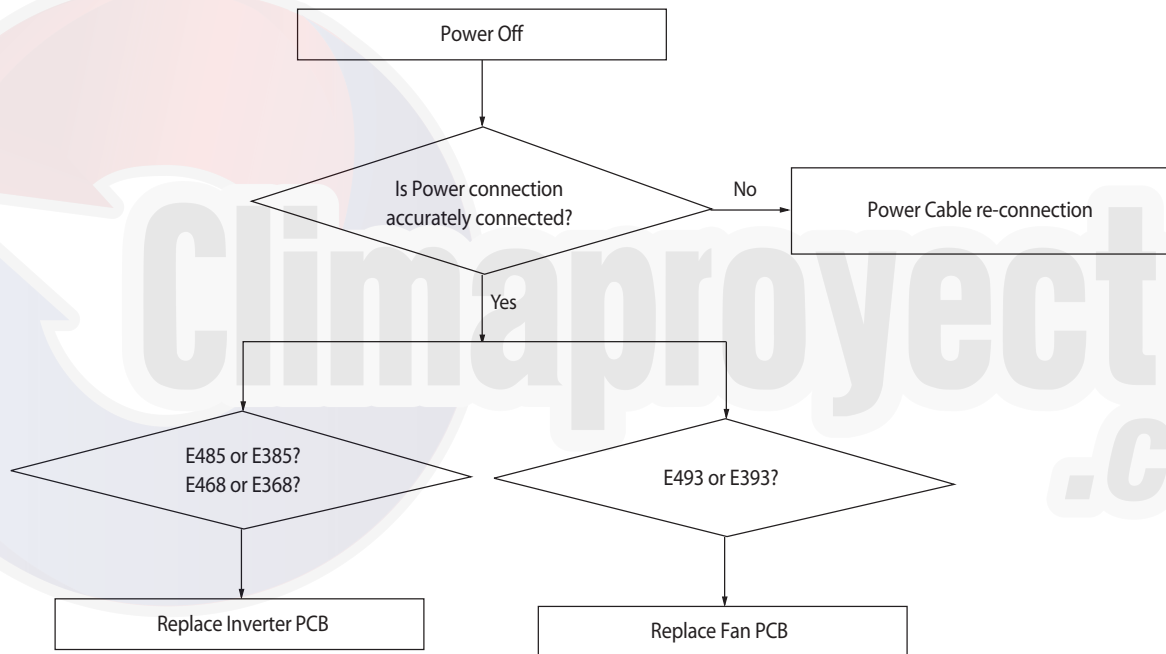

4-3-40. Outdoor Fan PCB Overvoltage / Low voltage error

Inverter / Hydro control part display	E486
Judgment Method	<ul style="list-style-type: none"> · N-phase wiring error and EMI Fuse short. · DC-Link Overvoltage / Low voltage occurs.
Cause of problem	<ul style="list-style-type: none"> · Check the input wiring · EMI Fuse short

1. Inspection Method

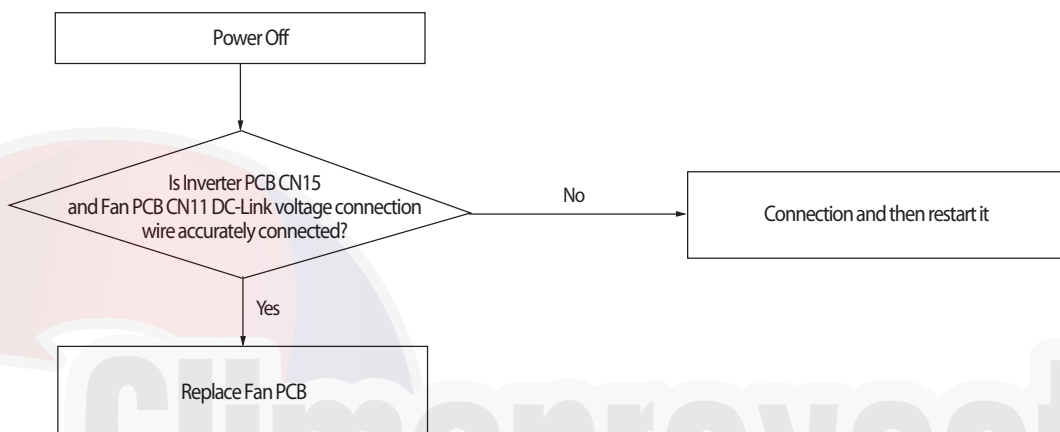

4-3-41. Hall IC (Fan) error

Inverter / Hydro control part display	<i>E487</i> (FAN PCB(FAN1)) <i>E387</i> (FAN PCB(FAN2))
Judgment Method	<ul style="list-style-type: none"> · Fan rotation defective or vibration and noise of the defective operation. · Hall IC there is no signal input.
Cause of problem	<ul style="list-style-type: none"> · Connection status error. · Hall IC wire disconnection. · Defective circuit parts and defective manufacturing. · Fan Motor defective.

1. Inspection Method

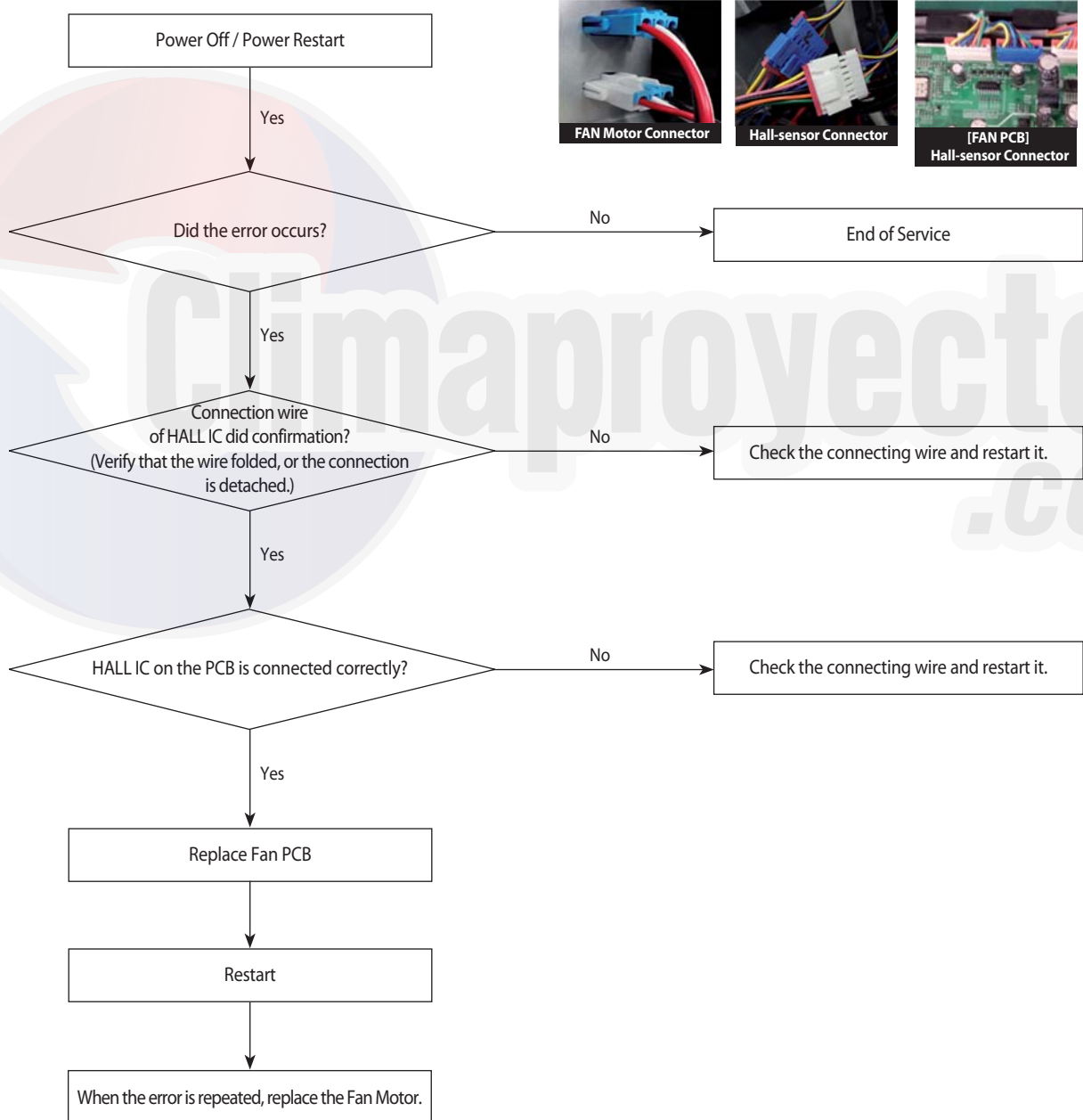

4-3-42. Inverter overheat error

Inverter / Hydro control part display	E500 (INVERTER1 PCB) E400 (INVERTER2 PCB)
Judgment Method	· IGBT module internal temperature : 105°C (221°F) more than (E500, E400)
Cause of problem	· Cooling Pin and the IGBT junction part assembly defective. · Refrigerant cooling heat sink and refrigerant piping assembly defective. · Assembled bolt defective.

Both end resistance values of IGBT module pin(8, 9 pin).

Temperature [°C]	Temperature [°F]	NTC [ohm]	AD [V]
10	50	9000	2.58
20	68	6000	2.33
30	86	4000	2.03
40	104	3000	1.80
50	122	2000	1.47
60	140	1600	1.29
70	158	1200	1.07
80	176	750	0.76
90	194	650	0.68
100	212	500	0.55
105	221	450	0.51
110	230	380	0.44
120	248	300	0.35
130	266	250	0.30
140	284	200	0.25

1. Inspection Method

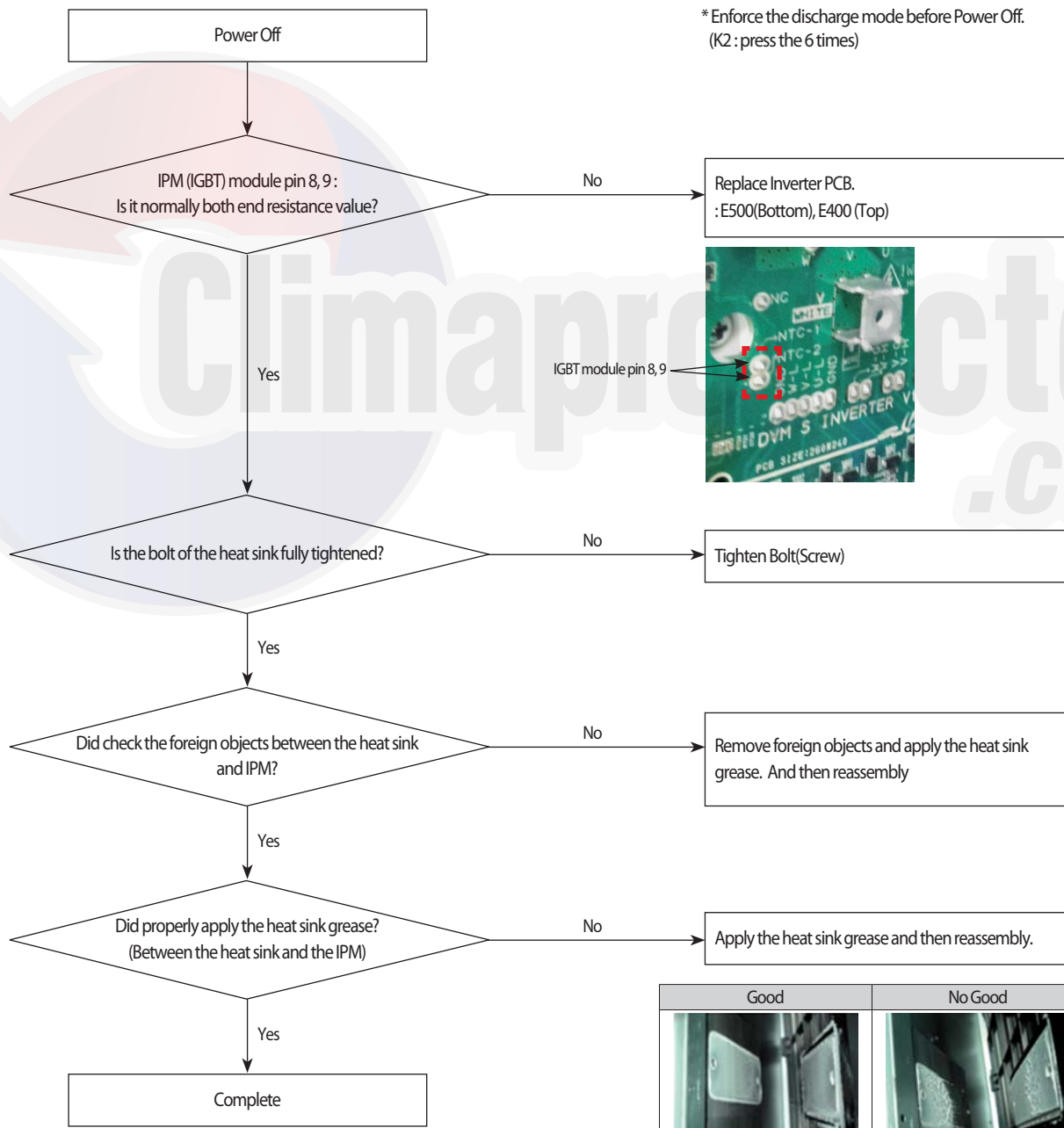

4-3-43. Option setting error of outdoor unit

Inverter / Hydro control part display	<i>E560</i>
Judgment Method	Refer to the inspection method below.
Cause of problem	Option setting error of outdoor unit. (E2P option use of other model or set of the relevant outdoor unit, compressor breakdown)

1. Inspection Method

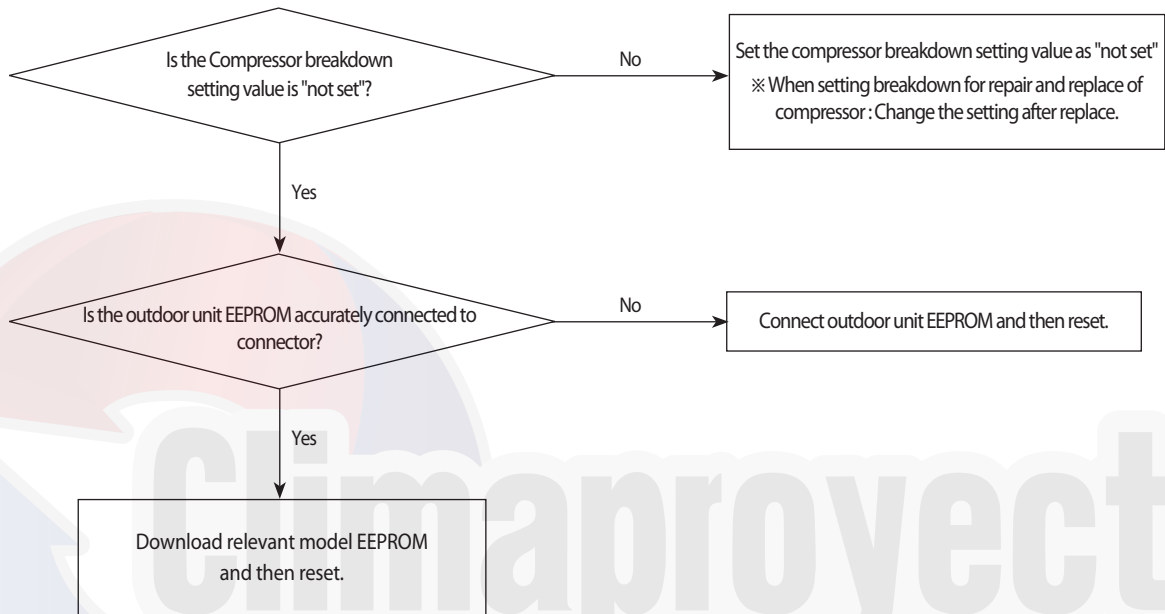

4-3-44. Hydro inlet temperature sensor (Tw1) Short/Open

Inverter / Hydro control part display	E901
Judgment Method	Refer to the inspection method below.
Cause of problem	Hydro Unit Water In Temperature Sensor Open/Short error

1. Inspection Method

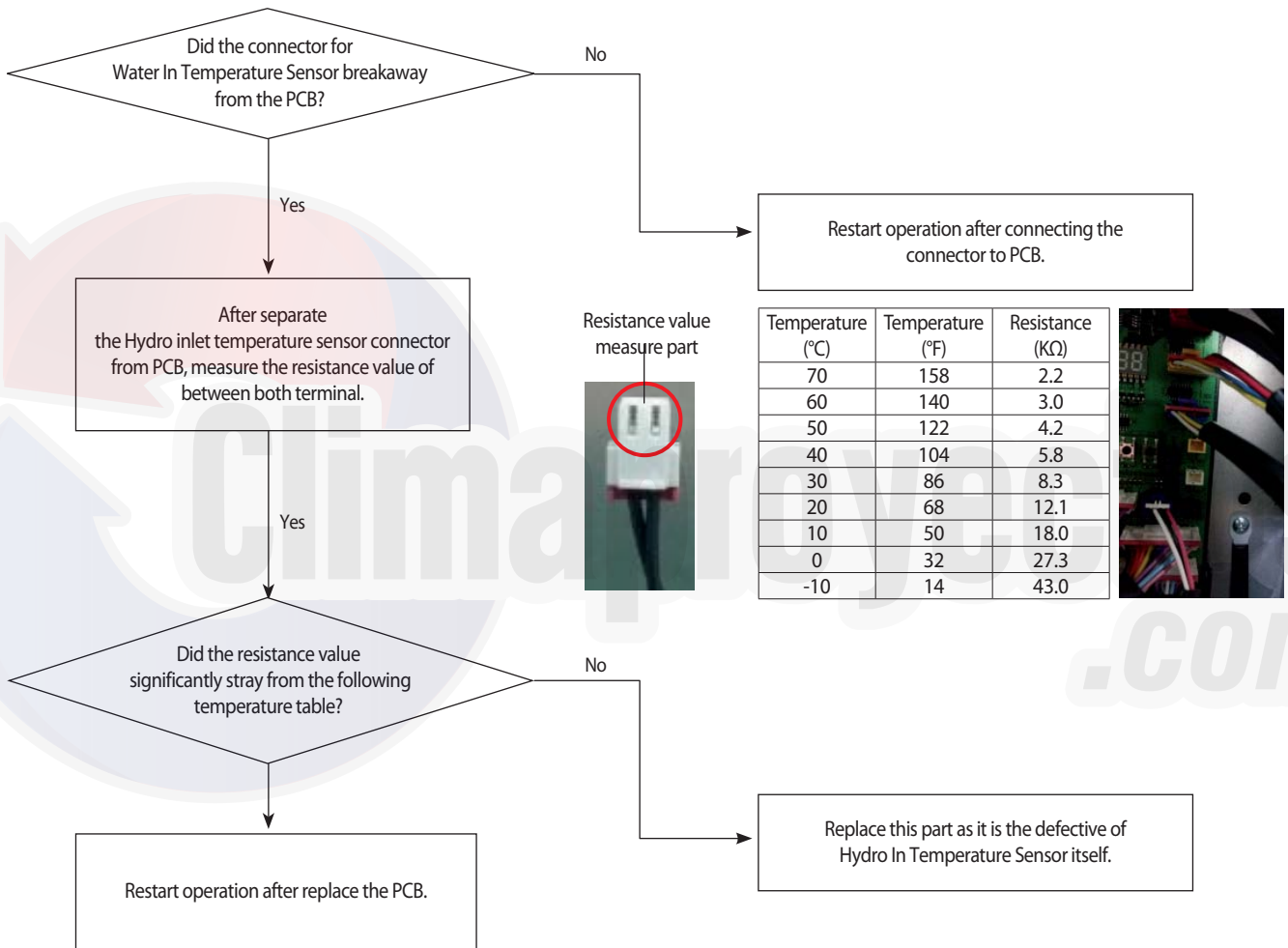

4-3-45. Hydro outlet temperature sensor (Tw2) Short/Open

Inverter / Hydro control part display	<i>E902</i>
Judgment Method	Refer to the inspection method below.
Cause of problem	Hydro Unit Water Out Temperature Sensor Open/Short error.

1. Inspection Method

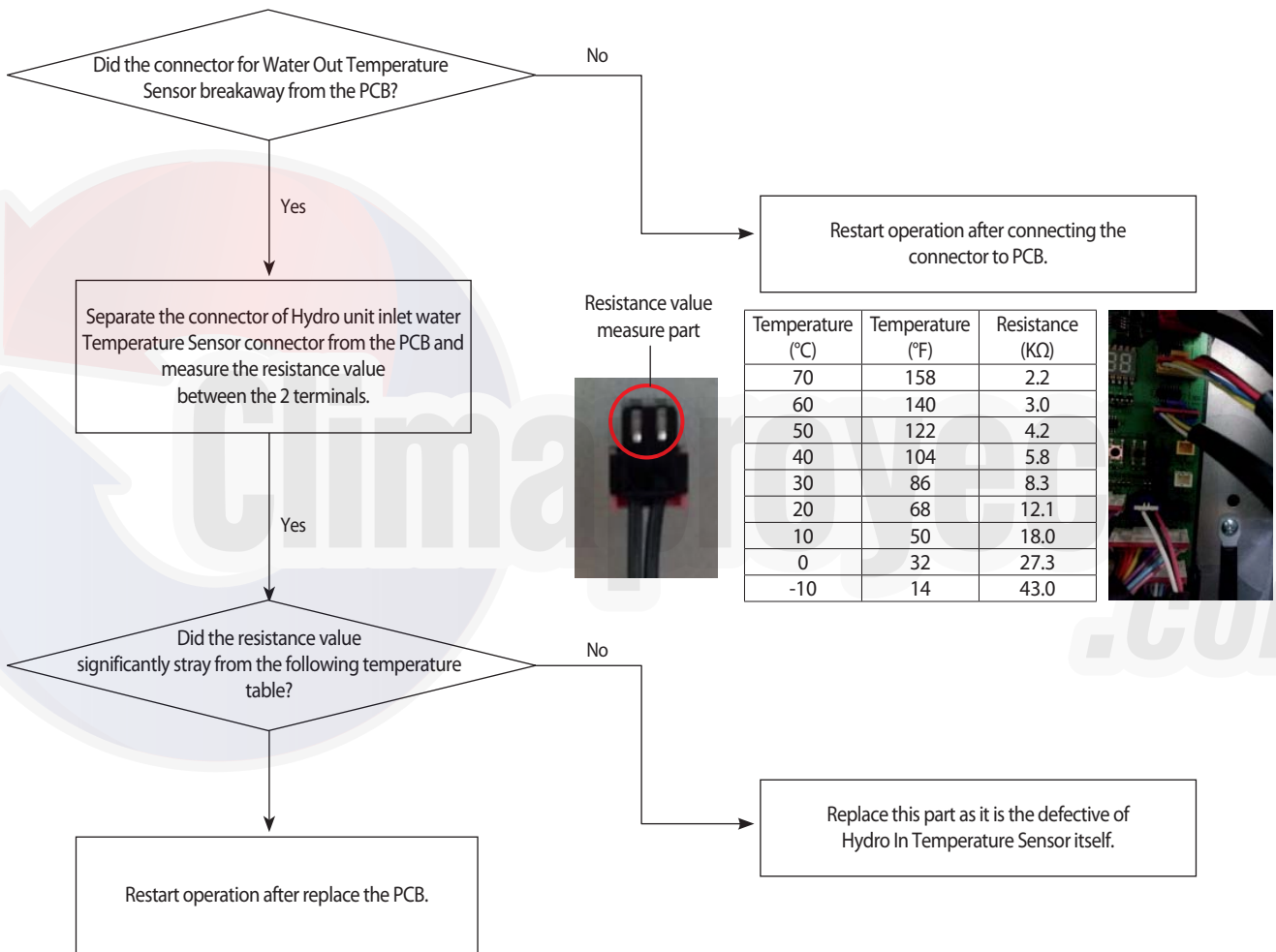

4-3-46. Frozen damage error

Inverter / Hydro control part display	E907
Judgment Method	Water outlet temperature dose not change more than 3°C (37.4°F). EVA In/Out maintains the temperature below 0°C (32.0°F).
Cause of problem	Indoor temperature of Hydro heat exchanger is low.(flow/temperature is low)

1. Inspection Method

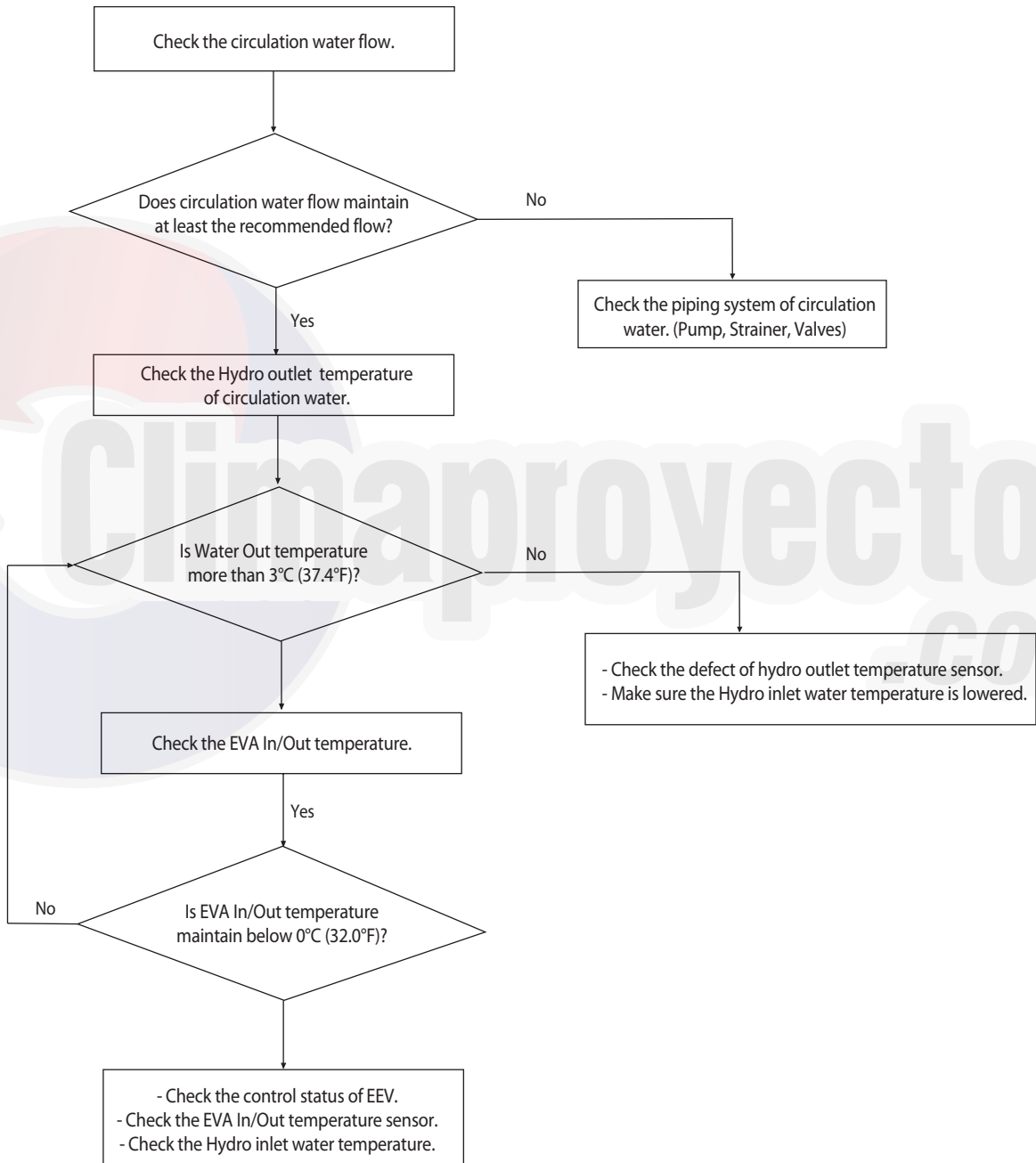

4-3-47. Error when freeze prevention Comp Off

Inverter / Hydro control part display	E908 (Possibility of restarting in once ~ 3 times) E909 (Stopping on 4 times)
Judgment Method	Water outlet temperature dose not change more than 3°C (37.4°F) EVA In/Out maintains the temperature below 0°C (32.0°F). During the cooling operation, can be detected
Cause of problem	Indoor temperature of Hydro heat exchanger is low.(flow/temperature is low)

1. Inspection Method

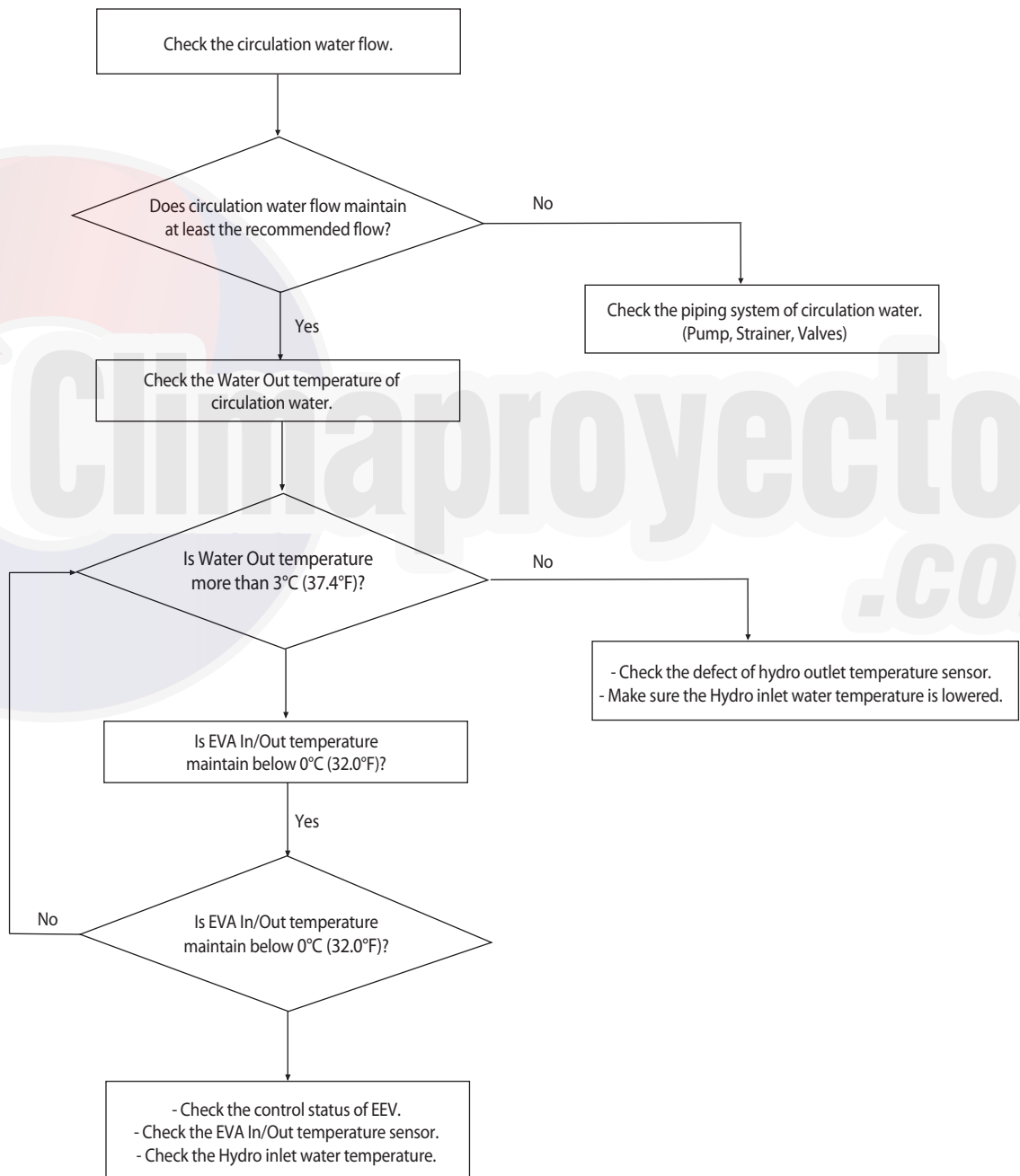

4-3-48. Hydro outlet temperature sensor Breakaway

Inverter / Hydro control part display	E9 10
Judgment Method	Water Outlet temperature before and after the operation : Temperature difference is less than 2°C (3.6°F).
Cause of problem	Breakaway of Hydro outlet temperature sensor

1. Inspection Method

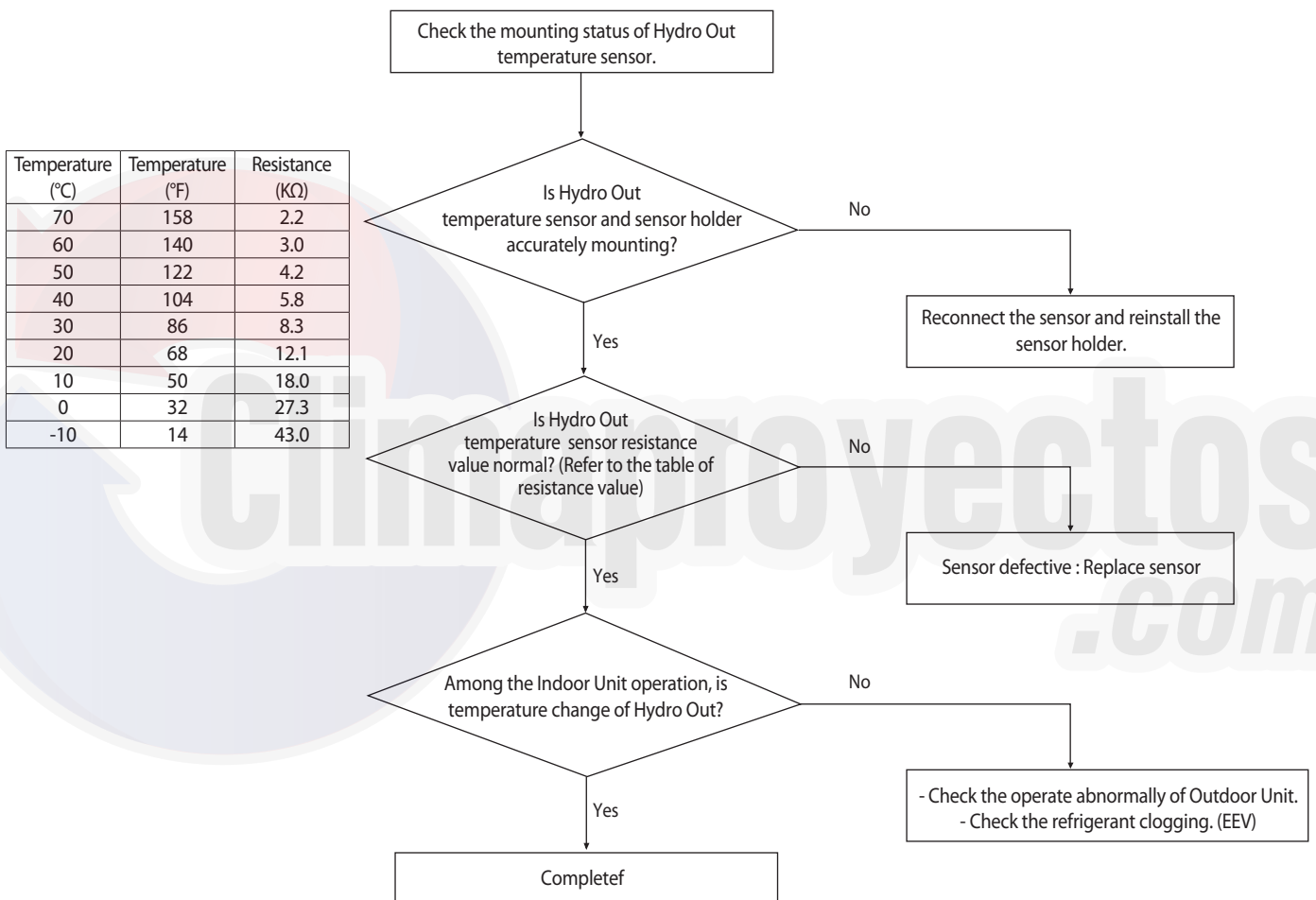

4-3-49. Water flow error (Water pressure sensor)

Inverter / Hydro control part display	<i>E911</i> (Auto-restarting in once ~ 5 times) <i>E913</i> (Stopping on 6 times)
Judgment Method	Output status from Pump signal : Does not detect the signal of Flow sensor, more than 5 seconds.
Cause of problem	Does not detect the signal of Flow sensor. (Flow shortage of Water piping system)

1. Inspection Method

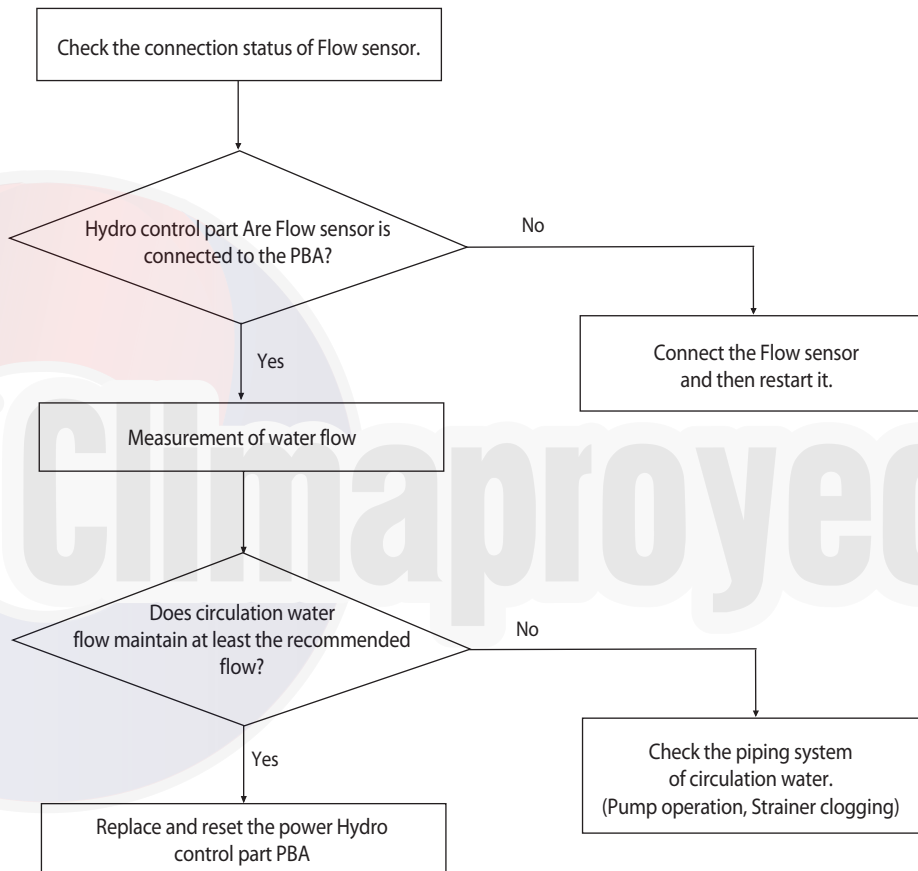

4-3-50. Error on pump magnetic switch malfunction

Inverter / Hydro control part display	<i>E9 18</i>
Judgment Method	Refer to the inspection method below.
Cause of problem	Pump Magnetic Switch Malfunction

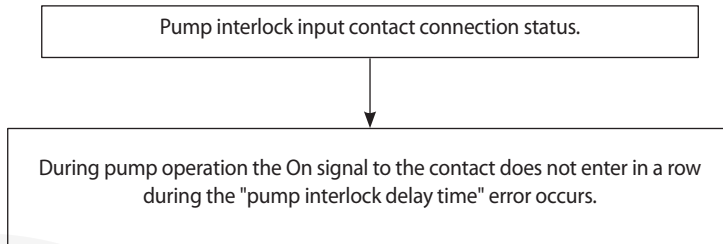

Pump interlock delay time : Setting options see Hydro

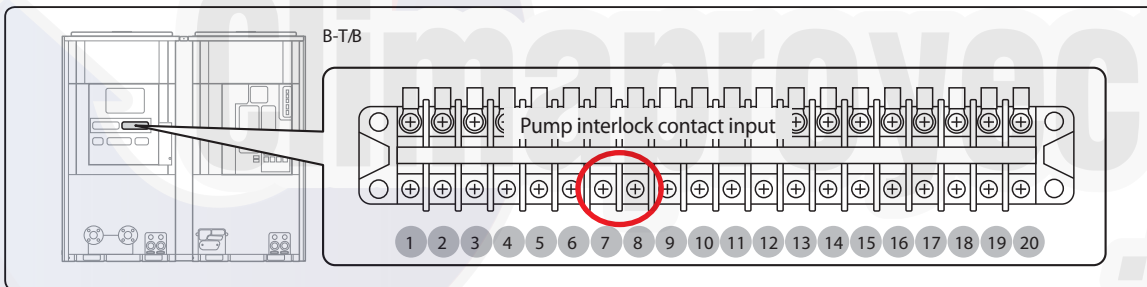

5. PCB Diagram and Parts List

5-1. ASSY PCB MAIN-HYDRO

- Model : All models name is commonness

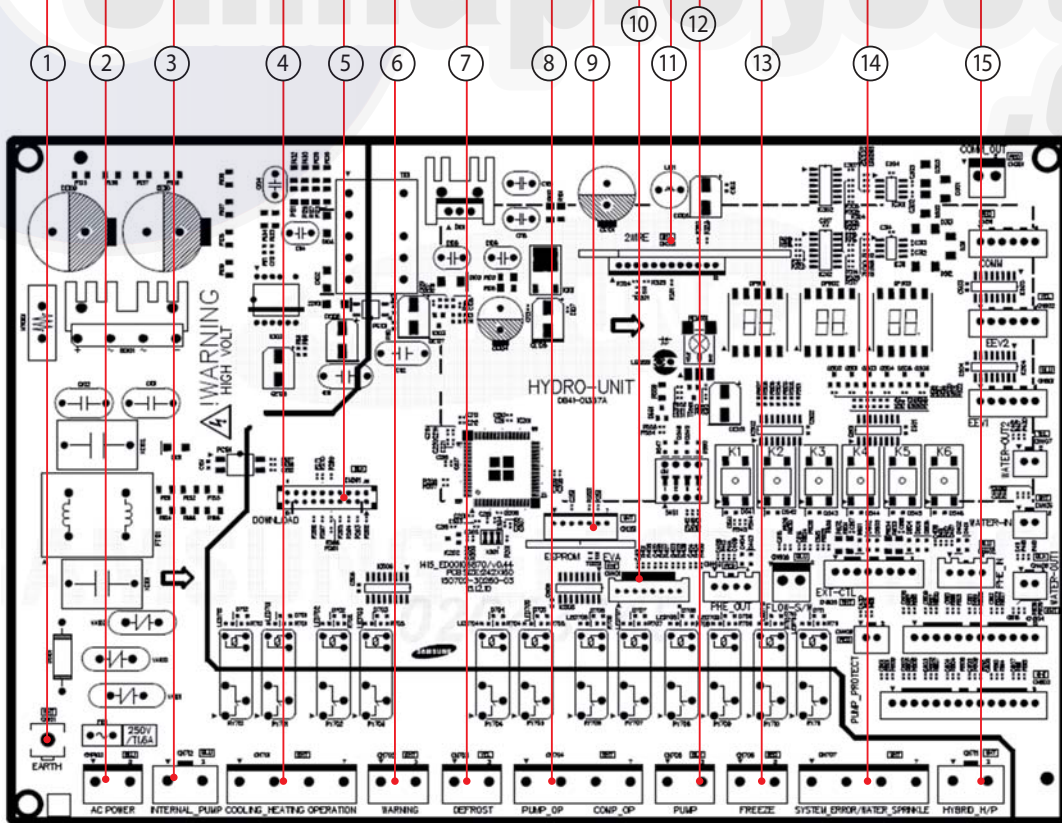
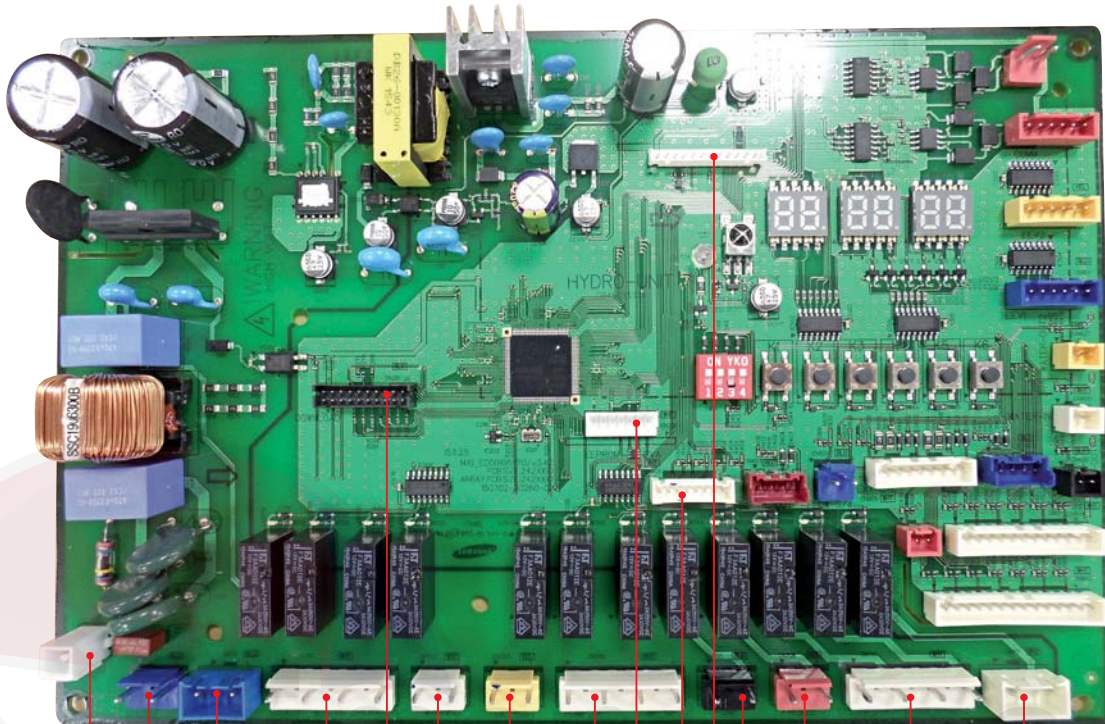

ASSY PCB MAIN-HYDRO (cont.)

- Model : All models name is commonness

<p>① CN101-EARTH</p> <p>#1 : EARTH</p>	<p>② CNP102-AC POWER</p> <p>#1 : LIVE</p> <p>#2 :</p> <p>#3 : NEUTRAL</p>	<p>③ CN712-INTERNAL PUMP</p> <p>#1 : NEUTRAL</p> <p>#2 :</p> <p>#3 : LIVE SIGNAL</p>	<p>④ CN701-OUTPUT</p> <p>#1 : COOLING_HEATING_DP SIGNAL</p> <p>#2 :</p> <p>#3 : COOLING_HEATING_DP SIGNAL</p> <p>#4 :</p> <p>#5 : OPERATION_DP SIGNAL</p> <p>#6 :</p> <p>#7 : OPERATION_DP SIGNAL</p>
<p>⑤ CN261-DOWNLOAD</p> <p>#1 : COM1_RXD</p> <p>#2 : COM1_TXD</p> <p>#3 : nTRST</p> <p>#4 : TDO</p> <p>#5 : TCK</p> <p>#6 : TDI</p> <p>#7 : TMS</p> <p>#8 : TRACE_CLK</p> <p>#9 : GND</p> <p>#10 : 5V</p> <p>#11 : 5V</p> <p>#12 : MODE0</p> <p>#13 : RESET</p> <p>#14 : TRACE 3</p> <p>#15 : DOWNLOAD</p> <p>#16 : SEGMENT_1</p> <p>#17 : GND</p> <p>#18 : TRACE 2</p> <p>#19 : TRACE 1</p> <p>#20 : TRACE 0</p>	<p>⑥ CN702-OUTPUT</p> <p>#1 : WARNING_DP SIGNAL</p> <p>#2 :</p> <p>#3 : WARNING_DP SIGNAL</p>	<p>⑦ CN703-OUTPUT</p> <p>#1 : DEFROST_OP_DP SIGNAL</p> <p>#2 :</p> <p>#3 : DEFROST_OP_DP SIGNAL</p>	<p>⑧ CN704-OUTPUT</p> <p>#1 : PUMP_OP_DP SIGNAL</p> <p>#2 :</p> <p>#3 : PUMP_OP_DP SIGNAL</p> <p>#4 :</p> <p>#5 : COMP_OP_DP SIGNAL</p> <p>#6 :</p> <p>#7 : COMP_OP_DP SIGNAL</p>
<p>⑨ CN251-EEPROM</p> <p>#1 : GND</p> <p>#2 :</p> <p>#3 : 5V</p> <p>#4 : EEPROM_SELECT</p> <p>#5 : EEPROM_SO</p> <p>#6 : EEPROM_SI</p> <p>#7 : EEPROM_CLK</p>	<p>⑩ CN401-TEMP SENSOR</p> <p>#1 : EVA1_IN_TEMP</p> <p>#2 : GND</p> <p>#3 : EVA1_OUT_TEMP</p> <p>#4 : GND</p> <p>#5 : EVA2_IN_TEMP</p> <p>#6 : GND</p> <p>#7 : EVA2_OUT_TEMP</p> <p>#8 : GND</p>	<p>⑪ CN705-OUTPUT</p> <p>#1 : PUMP_OP SIGNAL</p> <p>#2 :</p> <p>#3 : PUMP_OP SIGNAL</p>	<p>⑫ CN321-2-WIRE SUB PCB</p> <p>#1 : 12V</p> <p>#2 : COM2_PCTRL_MICOM</p> <p>#3 : COM2_VCHECK_A</p> <p>#4 : COM2_VCHECK_B</p> <p>#5 : COM2_MICOM_AD</p> <p>#6 : 5V</p> <p>#7 : COM2_ENABLE</p> <p>#8 : COM2_F3</p> <p>#9 : COM2_F4</p> <p>#10 : COM2_Tx</p> <p>#11 : COM2_Rx</p> <p>#12 : GND</p>
<p>⑬ CN251-EEPROM</p> <p>#1 : FREEZE_PROTECTION_DP SIGNAL</p> <p>#2 :</p> <p>#3 : FREEZE_PROTECTION_DP SIGNAL</p>	<p>⑭ CN401-TEMP SENSOR</p> <p>N/A</p>	<p>⑮ CN711-OUTPUT</p> <p>N/A</p>	

ASSY PCB MAIN-HYDRO (cont.)

- Model : All models name is commonness

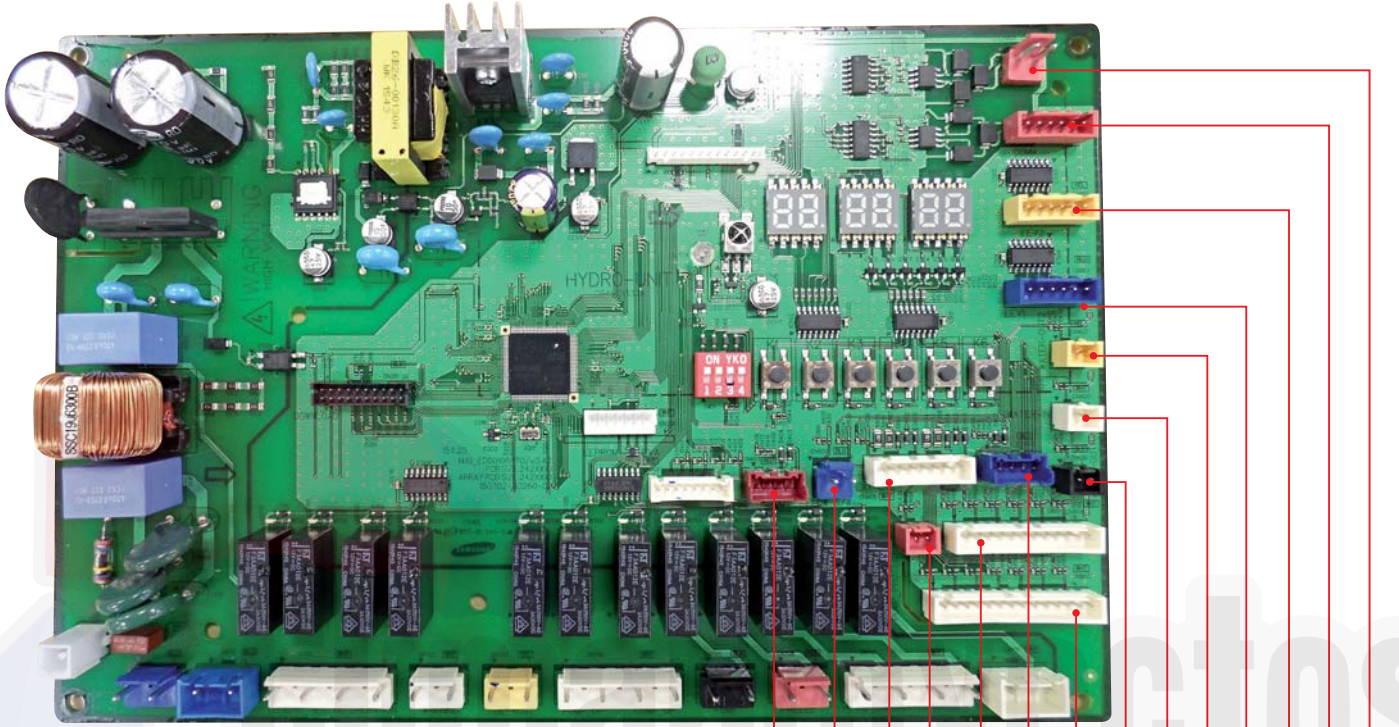

- ①
- ②
- ③
- ④
- ⑤
- ⑥
- ⑦
- ⑧
- ⑨
- ⑩
- ⑪
- ⑫
- ⑬
- ⑭

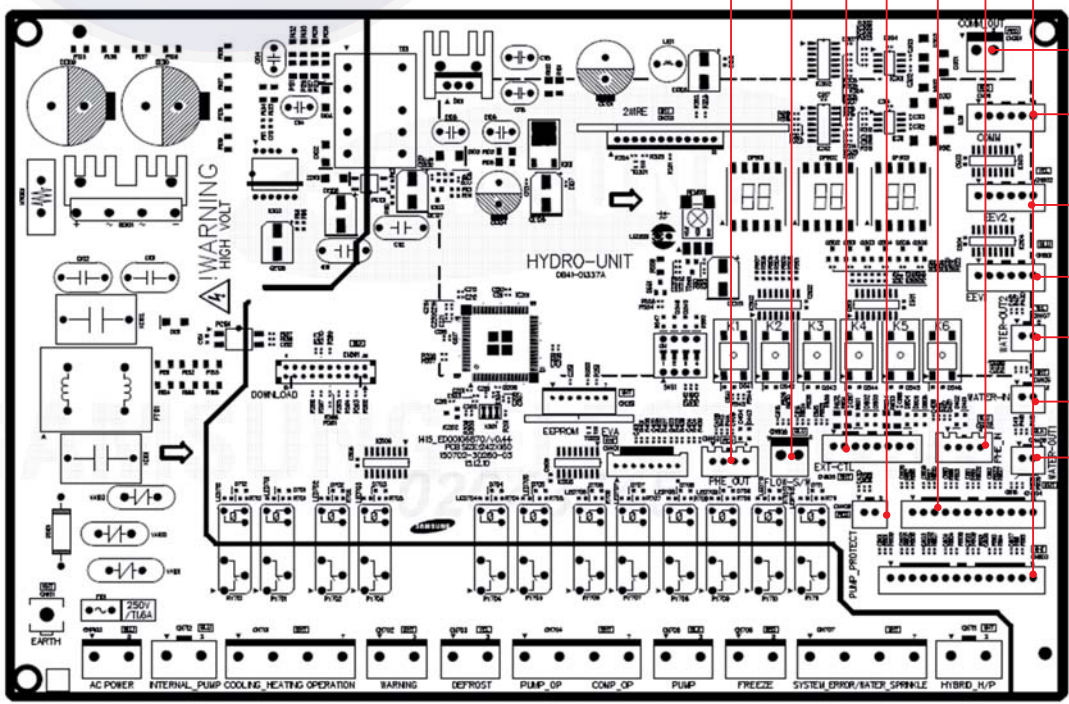

ASSY PCB MAIN-HYDRO (cont.)

- Model : All models name is commonness

<p>① CN403-PRESSURE SENSOR</p> <p>#1 : #2 : PHE_OUT SIGNAL #3 : GND #4 : 5V</p>	<p>② CN806-FLOW SWITCH</p> <p>#1 : FLOW SWITCH SIGNAL #2 : GND</p>	<p>③ CN05-INPUT</p> <p>#1 : N/A #2 : N/A #3 : N/A #4 : N/A #5 : SET TEMP #6 : GND #7 : EXT_WATER_OUT TEMP #8 : GND</p>	<p>④ CN408-INPUT</p> <p>#1 : PUMP_PROTECTION TEMP #2 : GND</p>
<p>⑤ CN804-INPUT</p> <p>#1 : NIGHT_LOW_NOISE_OP SIGNAL #2 : GND #3 : DEMAND_OP SIGNAL #4 : GND #5 : FAN_FORCE_OP SIGNAL #6 : GND #7 : UNUSUAL_CONDITION_RESET SIGNAL #8 : GND #9 : N/A #10 : N/A #11 : WATER_LAW #12 : GND</p>	<p>⑥ CN402-PRESSURE SENSOR</p> <p>#1 : #2 : PHE_IN SIGNAL #3 : GND #4 : 5V</p>	<p>⑦ CN803-INPUT</p> <p>#1 : PUMP_INTERLOCK SIGNAL #2 : GND #3 : OPERATION_ON SIGNAL #4 : GND #5 : OPERATION_OFF SIGNAL #6 : GND #7 : OPERATION_MODE SIGNAL #8 : GND #9 : THERMAL_STORAGE_OP SIGNAL #10 : GND #11 : THERMAL_STORAGE_CTRL SIGNAL #12 : GND #13 : THERMAL_STORAGE_THERMO SIGNAL #14 : GND</p>	<p>⑧ CN406-INPUT</p> <p>#1 : WATER_OUT1 TEMP #2 : GND</p>
<p>⑨ CN405-INPUT</p> <p>#1 : WATER_IN TEMP #2 : GND</p>	<p>⑩ CN407-INPUT</p> <p>#1 : WATER_OUT2 TEMP #2 : GND</p>	<p>⑪ CN801-EEV 1</p> <p>#1 : EEV1_B_bar SIGNAL #2 : EEV1_A_bar SIGNAL #3 : EEV1_B SIGNAL #4 : EEV1_A SIGNAL #5 : 12V #6 : 12V</p>	<p>⑫ CN802-EEV 2</p> <p>#1 : EEV2_B_bar SIGNAL #2 : EEV2_A_bar SIGNAL #3 : EEV2_B SIGNAL #4 : EEV2_A SIGNAL #5 : 12V #6 : 12V</p>
<p>⑬ CN311-COMM 2,3</p> <p>#1 : COM3_OF1 #2 : COM3_OF2 #3 : 12V #4 : GND #5 : COM2_F3 #6 : COM2_F4</p>	<p>⑭ CN301-COMM 1</p> <p>#1 : OUTDOOR F1 #2 : OUTDOOR F2</p>		

5-2. ASSY PCB MAIN

- Model : All models name is commonness

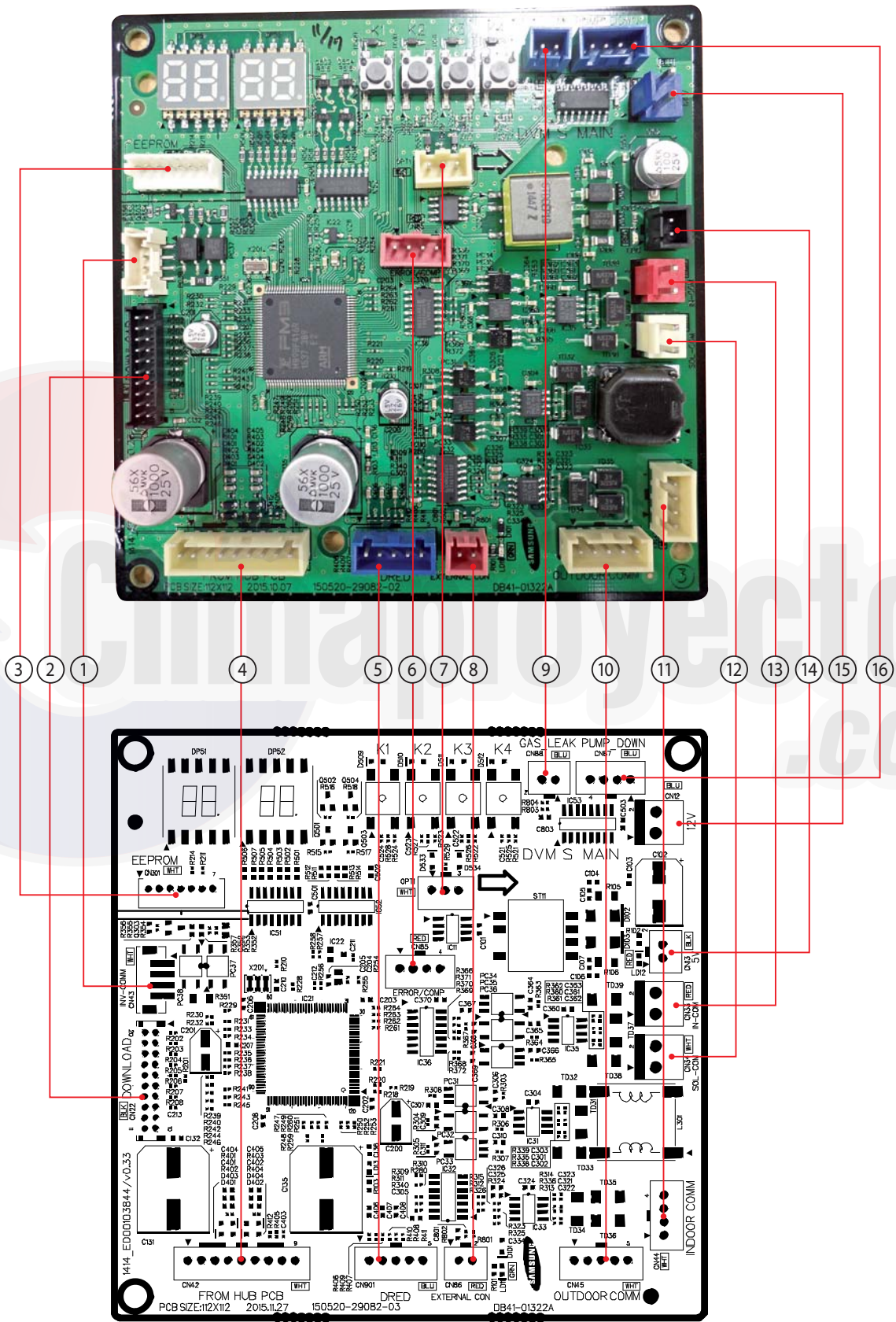

ASSY PCB MAIN (cont.)

- Model : All models name is commonness

<p>① CN43-INV COMM</p> <p>#1 : 5V #2 : RXD_INVERTER SIGNAL #3 : INV_COMM SIGNAL #4 : GND</p>	<p>② CN22-DOWNLOAD</p> <p>#1 : RXD_IN #2 : TXD_IN #3 : nTRST #4 : TDO #5 : TCK #6 : TDI #7 : TMS #8 : TRACE_CLK#9 : GND #10 : 5V #11 : 5V #12 : MODE0 #13 : RESET_MAIN #14 : TRACE 3 #15 : #16 : #17 : GND #18 : TRACE 2#19 : TRACE 1 #20 : TRACE 0</p>	<p>③ CN301-EEPROM</p> <p>#1 : GND #2 : #3 : 5V #4 : EEPROM_SELECT #5 : EEPROM_SO #6 : EEPROM_SI #7 : EEPROM_CLOCK</p>	<p>④ CN42-FROM HUB PCB</p> <p>#1 : 12V #2 : INVERTER1_INRUSH_OUT SIGNAL #3 : INV_COMM SIGNAL #4 : GND #5 : HIGH_PRESSURE_SENSOR #6 : LOW_PRESSURE_SENSOR #7 : ZERO_CROSSING SIGNAL #8 : GND #9 : 5V</p>
<p>⑤ CN901-DRED</p> <p>#1 : DRED1 SIGNAL #2 : DRED2 SIGNAL #3 : DRED3 SIGNAL #4 : GND #5 : 5V</p>	<p>⑥ CN85-ERROR/COMP</p> <p>#1 : 12V #2 : ERROR_CHECK_OUT SIGNAL #3 : 12V #4 : COMP_CHECK_OUT SIGNAL</p>	<p>⑦ OP1-OPTION SWITCH</p> <p>#1 : KEY_IN_3 SIGNAL #2 : GRID_8 SIGNAL #3 : KEY_IN_4 SIGNAL</p>	<p>⑧ CN86-EXTERNAL CONTROL</p> <p>#1 : EXTERNAL_CONTROL SIGNAL #2 : GND</p>
<p>⑨ CN88-GAS LEAK</p> <p>#1 : GAS_LEAK SIGNAL #2 : GND</p>	<p>⑩ CN45-OUTDOOR COMM</p> <p>#1 : COM_C #2 : COM_D #3 : #4 : 12V #5 : GND</p>	<p>⑪ CN44-INDOOR COMM</p> <p>#1 : COM_A #2 : COM_B #3 : 5V #4 : GND</p>	<p>⑫ CN34-SOL COM</p> <p>#1 : COM_E #2 : COM_F</p>
<p>⑬ CN33-IN COM</p> <p>#1 : COM_A #2 : COM_B</p>	<p>⑭ CN13-5V</p> <p>#1 : 5V #2 : GND</p>	<p>⑮ CN12-12V</p> <p>#1 : 12V #2 : GND</p>	<p>⑯ CN87-PUMP DOWN</p> <p>#2 : 12V #3 : PUMP_DOWN_END SIGNAL #4 : 12V</p>

5-3. ASSY PCB SUB-FAN

- Model : All models name is commonness

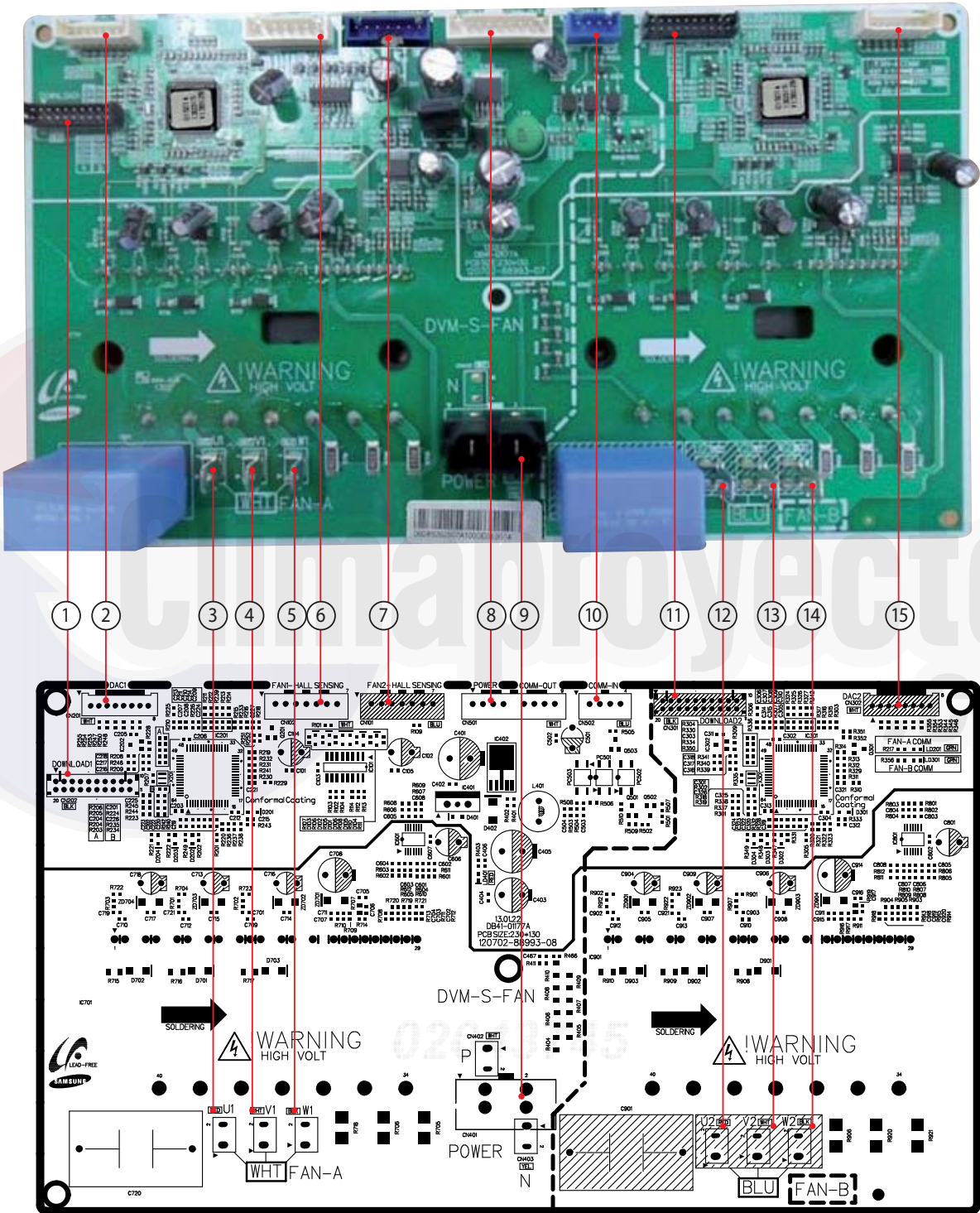

ASSY PCB SUB-FAN (cont.)

- Model : All models name is commonness

<p>① CN202-DOWNLOAD1</p> <p>#1:RXD_DEBUG1 #2:TXD_DEBUG1 #3:BOOT1 #4:TDO1 #5:TCK1 #6:TDI1 #7:TMS1 #8:#9:GND #10:5V #11: #12: #13: #14: #15: #16: #17: #18:#19: #20:</p>	<p>② CN201-DAC1</p> <p>#1:5V #2:VIEWER1_DAC1 #3:VIEWER2_DAC1 #4:VIEWER3_DAC1 #5:DATA_DAC1 #6:CS_DAC1 #7:CLK_DAC1 #8:GND</p>	<p>③ U1-FAN1 U</p> <p>#1:U</p>	<p>④ V1-FAN1 V</p> <p>#1:V</p>
<p>⑤ W1-FAN1 W</p> <p>#1:W</p>	<p>⑥ CN102-FAN1 HALL SENSING</p> <p>#1:HALL_U1 SIGNAL #2:5V #3:HALL_V1 SIGNAL #4:GND #5:HALL_W1 SIGNAL #6:MOTOR_TEMP1 #7:GND</p>	<p>⑦ CN101-FAN2 HALL SENSING</p> <p>#1:HALL_U2 SIGNAL #2:5V #3:HALL_V2 SIGNAL #4:GND #5:HALL_W2 SIGNAL #6:MOTOR_TEMP2 #7:GND</p>	<p>⑧ CN501-POWER/COMM-OUT</p> <p>#1:18V #2:GND #3: #4:GND #5: #6:12V #7:COMM SIGNAL #8:COMM_OUT SIGNAL #9:AGND</p>
<p>⑨ CN401-POWER</p> <p>#1:P_DC #2:GND</p>	<p>⑩ CN502-COMM-IN</p> <p>#1:12V #2:COMM SIGNAL #3:COMM_IN SIGNAL #4:AGND</p>	<p>⑪ CN301-DOWNLOAD2</p> <p>#1:RXD_DEBUG2 #2:TXD_DEBUG2 #3:BOOT2 #4:TDO2 #5:TCK2 #6:TDI2 #7:TMS2 #8:#9:GND #10:5V #11: #12: #13: #14: #15: #16: #17: #18: #19: #20:</p>	<p>⑫ U2-FAN2 U</p> <p>#1:U</p>
<p>⑬ V2-FAN2 V</p> <p>#1:V</p>	<p>⑭ W2-FAN2 W</p> <p>#1:W</p>	<p>⑮ CN302-DAC2</p> <p>#1:5V #2:VIEWER1_DAC2 #3:VIEWER2_DAC2 #4:VIEWER3_DAC2 #5:DATA_DAC2 #6:CS_DAC2 #7:CLK_DAC2 #8:GND</p>	

5-4. ASSY PCB SUB-EMI (F power model only)

- Model : AG010/015KSVAF* Series

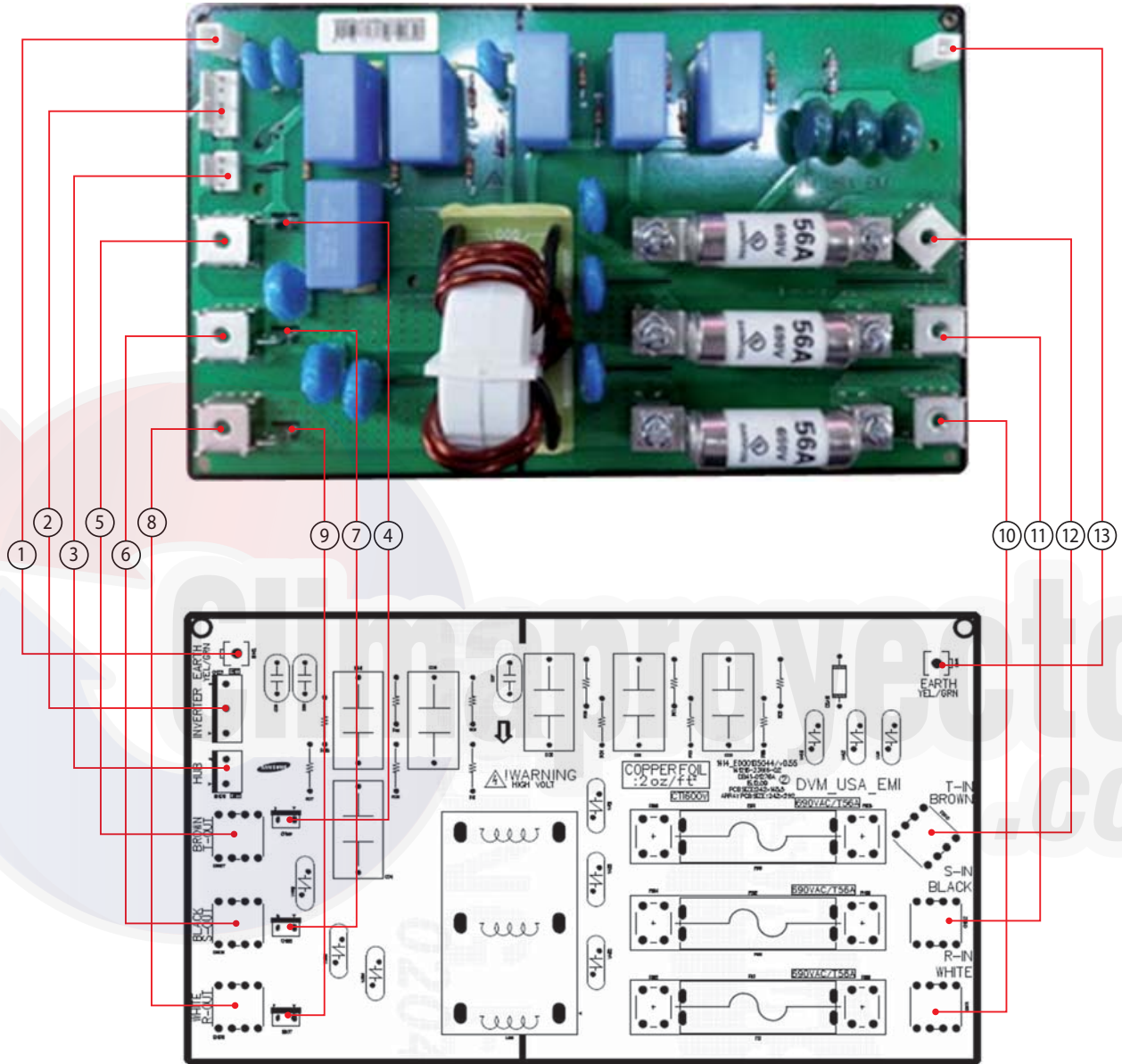

① CN42-EARTH #1 : EARTH	② CN23-CONNECT TO #1 : T #2 : #3 : S #4 : #5 : R	③ CN108-CONNECT TO HUB #1 : S #2 : #3 : T	④ CN09-T OUT #1 : T
⑤ CN107-T OUT #1 : T	⑥ CN106-S OUT #1 : S	⑦ CN08-S OUT #1 : S	⑧ CN105- R OUT #1 : R
⑨ CN07-R OUT #1 : R	⑩ CN101-R IN #1 : R	⑪ CN102-S IN #1 : S	⑫ CN103-T IN #1 : T
⑬ CN41-EARTH #1 : EARTH			

5-5. ASSY PCB SUB-EMI (J power model only)

- Model : AG010/015KSVAJ* Series

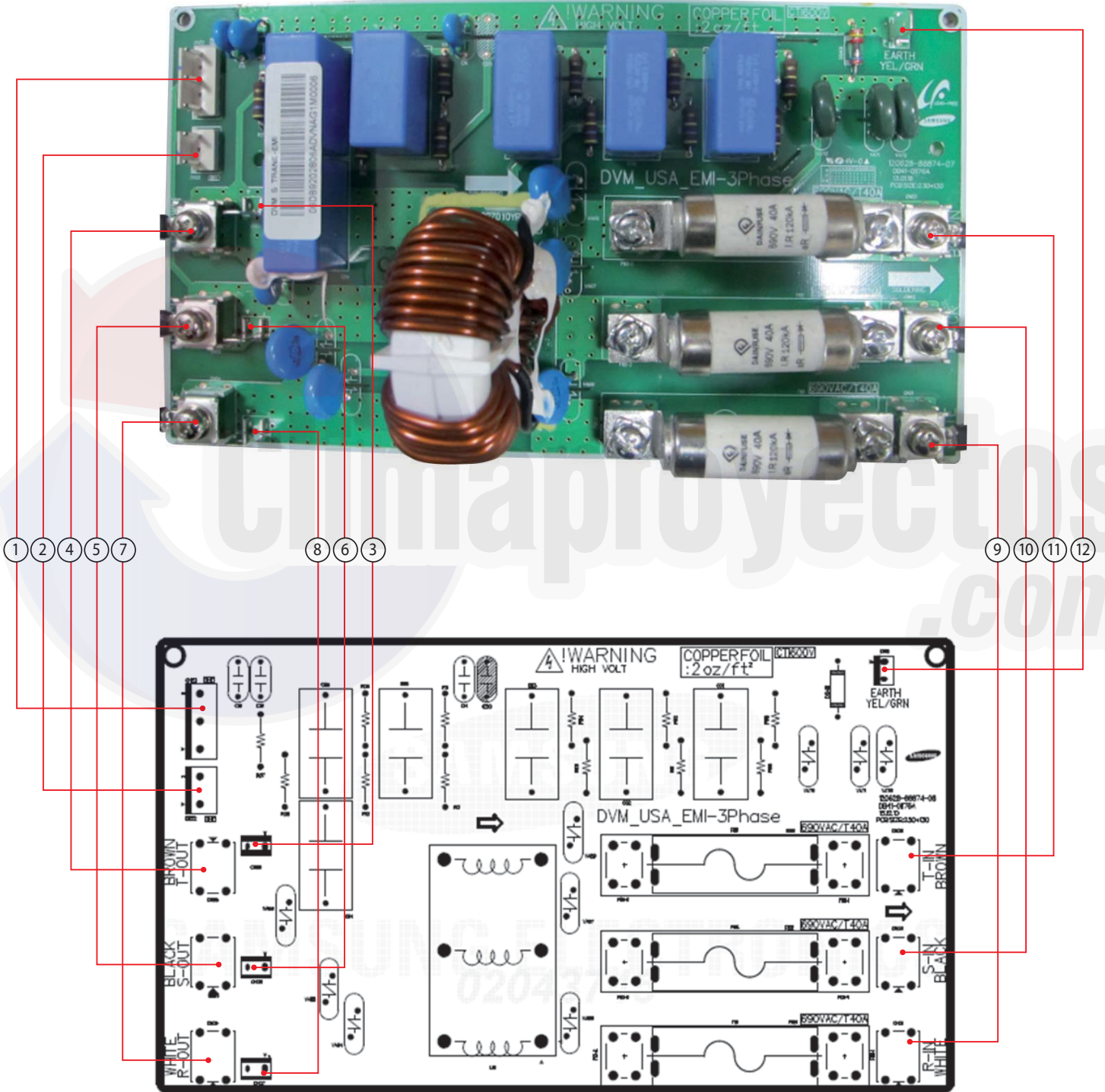

ASSY PCB SUB-EMI (J power model only) (cont.)

- Model : AG010/015KSVAJ* Series

① CN23-CONNECT TO INVERTER PCB #1:T #2: #3:S #4: #5:R	② CN22-CONNECT TO HUB #1:T #2: #3:S	③ CN09-T OUT #1:T	④ CN06-T OUT #1:T
⑤ CN05-S OUT #1:S	⑥ CN08-S OUT #1:S	⑦ CN04-R OUT #1:R	⑧ CN07-R OUT #1:R
⑨ CN01-R IN #1:R	⑩ CN02-S IN #1:S	⑪ CN03-T IN #1:T	⑫ CN10-EARTH #1:EARTH



ASSY PCB MAIN-HUB (cont.)

- Model : All models name is commonness

■ DC

<p>① CN83-EVI EEV</p> <p>#1 : EEV3_A_OUT #2 : EEV3_B_OUT #3 : EEV3_A'_OUT #4 : EEV3_B'_OUT #5 : 12V</p>	<p>② CN81-EEV1</p> <p>#1 : EEV1_B'_OUT #2 : EEV1_A'_OUT #3 : EEV1_B_OUT #4 : EEV1_A_OUT #5 : 12V #6 : 12V</p>	<p>③ CN82-EEV2</p> <p>#1 : EEV2_B'_OUT #2 : EEV2_A'_OUT #3 : EEV2_B_OUT #4 : EEV2_A_OUT #5 : 12V #6 : 12V</p>	<p>④ CN43-TEMP. SENSOR</p> <p>#1 : COMP1 DISACHRGE #2 : COMP1 DISCHARGE #3 : COMP1 TOP #4 : COMP1 TOP1 #5 : COND OUT #6 : COND OUT #7 : OUTDOOR TEMP. #8 : OUTDOOR TEMP.</p>
<p>⑤ CN45-TEMP. SENSOR</p> <p>#1 : LIQUID #2 : LIQUID #3 : COMP2 DISCHARGE #4 : COMP2 DISCHARGE #5 : COMP2 TOP #6 : COMP2 TOP</p>	<p>⑥ CN46-SUCT</p> <p>#1 : SUCTION 2 #2 : SUCTION 2 #3 : HEX2 (TOTAL SUCTION) #4 : HEX2 (TOTAL SUCTION) #5 : - #6 : GND</p>	<p>⑦ CN44 – TEMP. SENSOR</p> <p>#1 : SUCTION 1 #2 : SUCTION 1 #3 : EVI INLET #4 : ENI INLET #5 : ENI OUT #6 : EVI OUT</p>	<p>⑧ CN906 –SNOW SENSOR</p> <p>#1 : 12V #3 : GND #4 : SNOW_SENSOR #5 : PSD_POWER</p>
<p>⑨ CN42 –HIGH PRESSURE SENSOR</p> <p>#1 : HIGH PRESSURE SENSOR #3 : GND #4 : VCC</p>	<p>⑩ CN41- LOW PRESSURE SENSOR</p> <p>#2 : LOW PRESSURE SENSOR #3 : GND #4 : VCC</p>	<p>⑪ CN97- INV COMM</p> <p>#1 : 12V #2 : INV_SMPS_RELAY #3 : COMM OUT #4 : GND</p>	<p>⑫ CN96 – MAIN-HUB COMM.</p> <p>#1 : 12V #2 : INV_SMPS_RELAY #3 : COMM-MAIN #4 : GND #5 : HIGH-PRESSURE-SENSOR #6 : LOW-PRESSURE-SENSOR #7 : ZERO-CROSSING #8 : GND #9 : VCC</p>

ASSY PCB MAIN-HUB (cont.)

- Model : All models name is commonness

■ AC

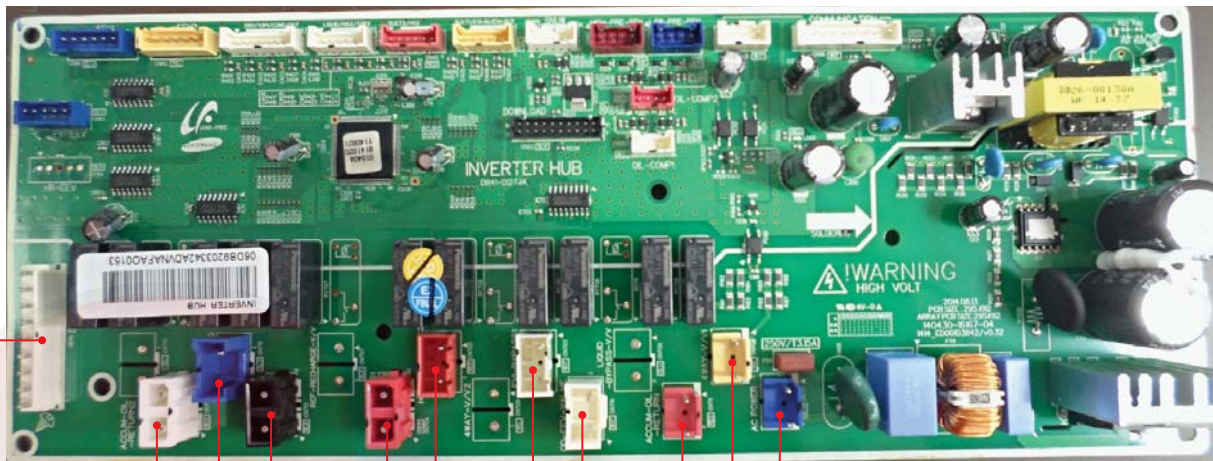

- 11
- 1
- 2
- 3
- 4
- 5
- 6
- 7
- 8
- 9
- 10

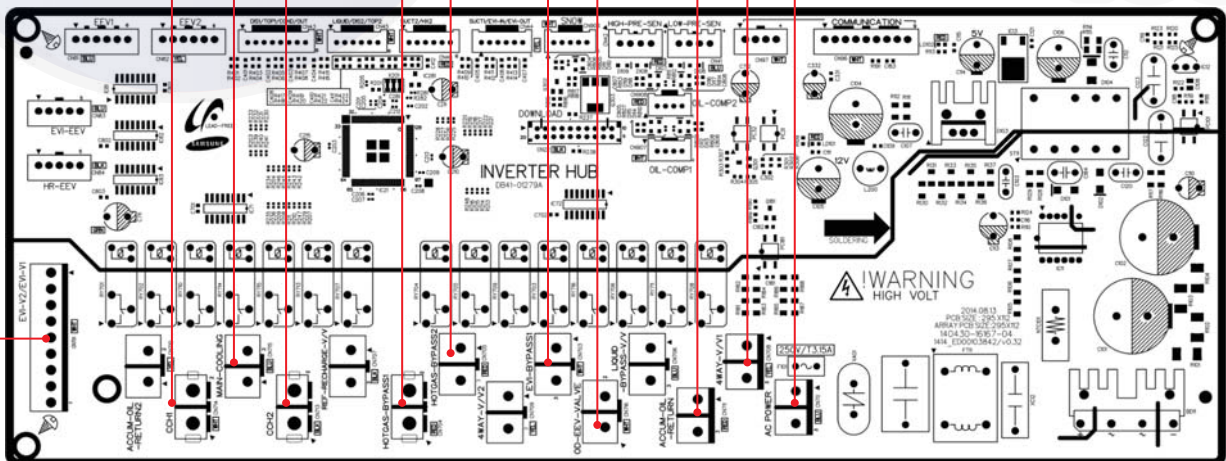

ASSY PCB MAIN-HUB (cont.)

- Model : All models name is commonness

■ AC (cont.)

<p>① CN714-CCH1</p> <p>#1 : CCH1 #2 : CCH1</p>	<p>② CN715-MAIN-COOLING</p> <p>#1 : MAIN-COOLING #2 : MAIN-COOLING</p>	<p>③ CN713-CCH2</p> <p>#1 : CCH2 #2 : CCH2</p>	<p>④ CN704-HOTGAS-VALVE1</p> <p>#1 : HOTGAS BYPASS1 #2 : HOTGAS BYPASS1</p>
<p>⑤ CN705-HOTGAS-BYPASS2</p> <p>#1 : HOTGAS BYPASS2 (OIL BYPASS VAVLE2) #2 : HOTGAS BYPASS2 (OIL BYPASS VAVLE2)</p>	<p>⑥ CN703-EVI-BYPASS</p> <p>#1 : EVI BYPASS1 #2 : EVI BYPASS1</p>	<p>⑦ CN716-OD-EEV-VALVE</p> <p>#1 : OD EEV VALVE (OIL BYPASS VAVLE1) #2 : OD EEV VALVE (OIL BYPASS VAVLE1)</p>	<p>⑧ CN711-OIL-RETURN-VALVE</p> <p>#1 : ACCUM OIL RETURN VALVE #2 : ACCUM OIL RETURN VALVE</p>
<p>⑨ CN708- 4-WAY-VALVE</p> <p>#1 : 4-WAY VALVE #2 : 4-WAY VALVE</p>	<p>⑩ CN70-AC POWER INPUT</p> <p>#1 : AC LIVE #2 : AC NEUTRAL</p>	<p>⑪ CN701 EVI VALVE 1,2</p> <p>#1 : EVI VALVE 1 #3 : EVI VALVE 2 #7 : EVI VALVE 1 #8 : EVI VALVE 2 #9 : AC NEUTRAL</p>	

Climaproyectos
.com

5-7. ASSY PCB INVERTER (F power model only)

- Model : AG010/015KSVAF* Series

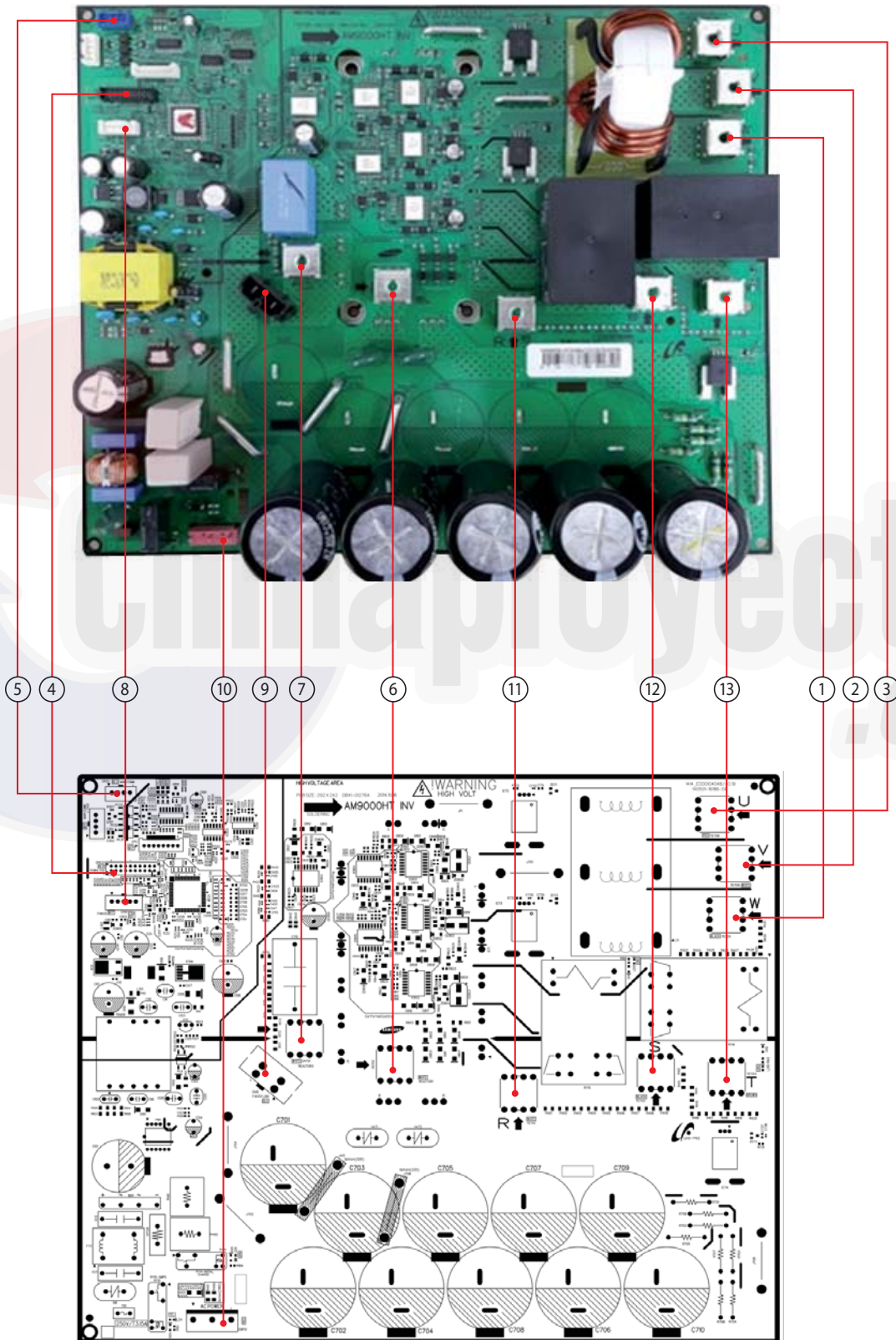

ASSY PCB INVERTER (F power model only) (cont.)

- Model : AG010/015KSVAF* Series

<p>① W-COMP W</p> <p>#1:COMP W</p>	<p>② U-COMP U</p> <p>#1:COMP U</p>	<p>③ V-COMP V</p> <p>#1:COMP V</p>	<p>④ CN22-DOWNLOAD</p> <p>#1:RX-DOWN #2:TX-DOWN #3:BOOT #4:TDO #5:TCK #6:TDI #7:TMS #9:GND #10:VCC</p>
<p>⑤ CN32-MAIN COMM</p> <p>#1:12V-MAIN #2:IN-SMPS-RELAY #3:COMM-IN #4:GND-MAIN</p>	<p>⑥ CN702-REACTOR1</p> <p>#1:REACTOR1</p>	<p>⑦ CN701-REACTOR2</p> <p>#1:REACTOR2</p>	<p>⑧ CN91-FAN DC</p> <p>#1:18V #2:GND #3:5V-FAN #4:AD-SELECT</p>
<p>⑨ CN15-FAN DCLINK</p> <p>#1:AC #2: #3:AC</p>	<p>⑩ CN13-AC POWER</p> <p>#1:AC LIVE #2:AC NEUTRAL #3:AC NEUTRAL</p>	<p>⑪ R-IN R</p> <p>#1:R-IN</p>	<p>⑫ S-IN S</p> <p>#1:S-IN</p>
<p>⑬ T-INT</p> <p>#1:T-IN</p>			

ASSY PCB INVERTER (J power model only) (cont.)

- Model : AG010/015KSVAJ* Series

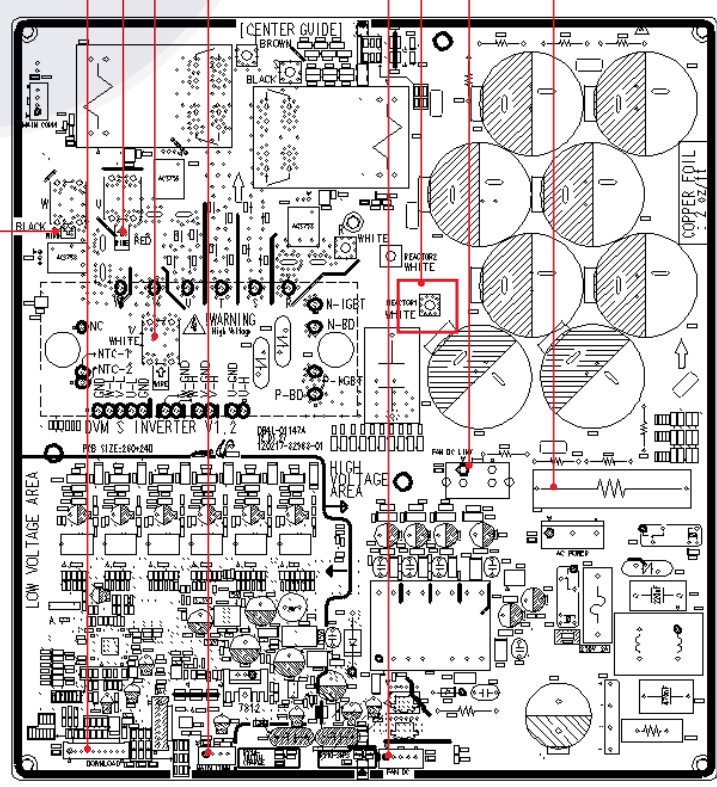
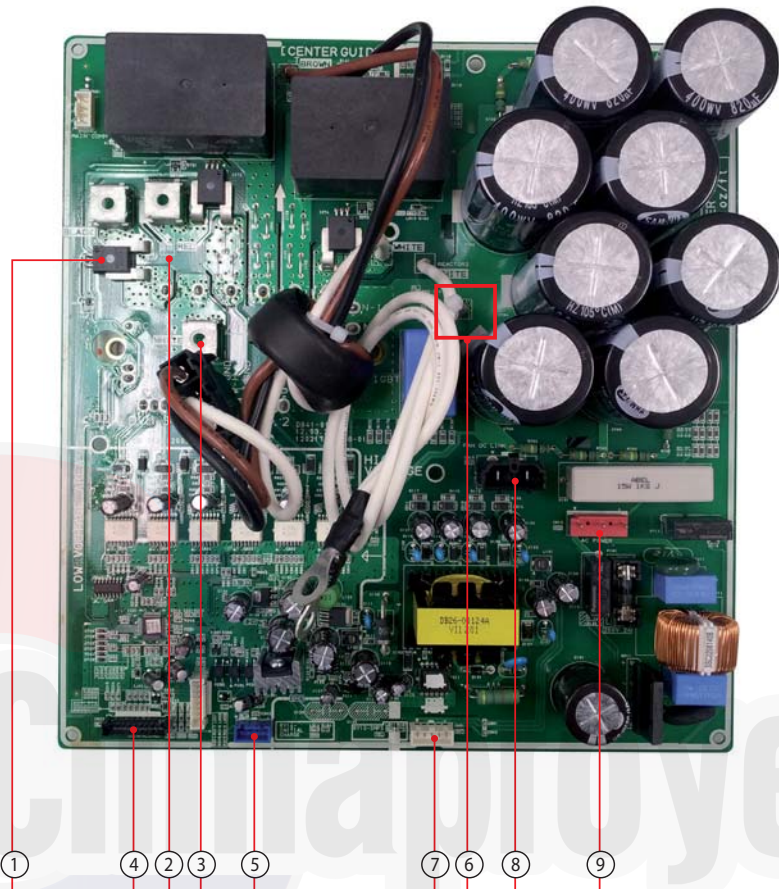

ASSY PCB INVERTER (J power model only) (cont.)

- Model : AG010/015KSVAJ* Series

<p>① W-COMPW</p> <p>#1:COMPW</p>	<p>② U-COMP U</p> <p>#1:COMP U</p>	<p>③ V-COMP V</p> <p>#1:COMPV</p>	<p>④ CN22-DOWNLOAD</p> <p>#1:RX-DOWN #2:TX-DOWN #3:N-TRST #4:TDO #5:TCK #6:TDI #7:TMS #8: #9:GND #10:VCC</p>
<p>⑤ CN32-MAIN COMM</p> <p>#1:12V-MAIN #2:IN-SMPS-RELAY #3:COMM-IN #4:GND-MAIN</p>	<p>⑥ REACTOR (WIRE CONNECTION)</p> <p>#1:REACTOR #2:REACTOR</p>	<p>⑦ CN91-FAN DC</p> <p>#1:18V #2:GND #3:5V-FAN #4:AD-SELECT</p>	<p>⑧ CN15-FAN DC LINK</p> <p>#1:500V #2:GND(500V)</p>
<p>⑨ CN13-ACPOWER</p> <p>#1:AC #2: #3:AC</p>			

5-8. ASSY PCB SUB-COMM

- Model : All models name is commonness

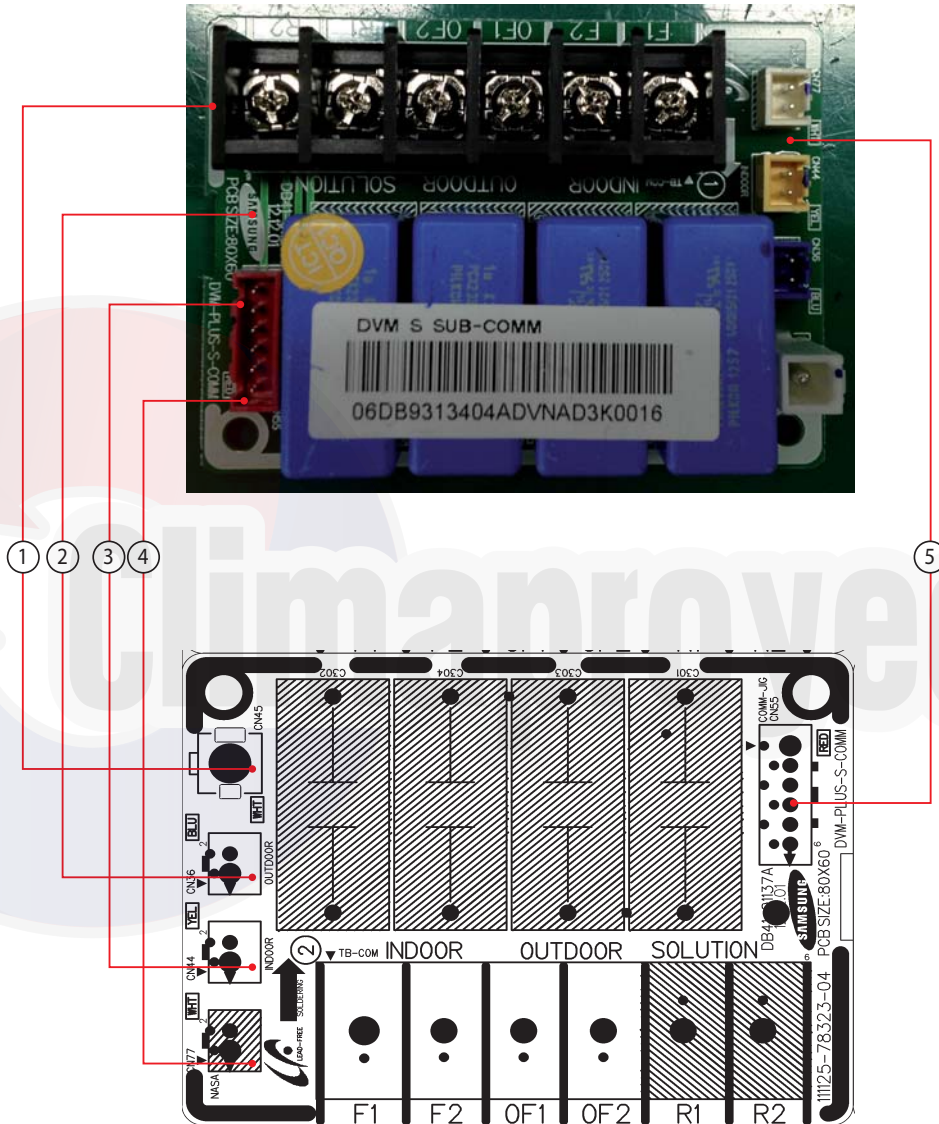

<p>① CN44</p> <p>#1:F1 #2:F2</p>	<p>② CN36</p> <p>#1:OF1 #2:OF2</p>	<p>③ CN#44</p> <p>#1:R1 #2:R2</p>	<p>④ CN45</p> <p>GND</p>	<p>⑤ CN55</p> <p>#1:F1 #2:F2 #3:OF1 #4:OF2 #5:R1 #6:R2</p>
---	---	--	---------------------------------	---

6. Wiring Diagram

6-1. DVM CHILLER hydro part wiring diagram

- Model : AG010/015KVA*** Series

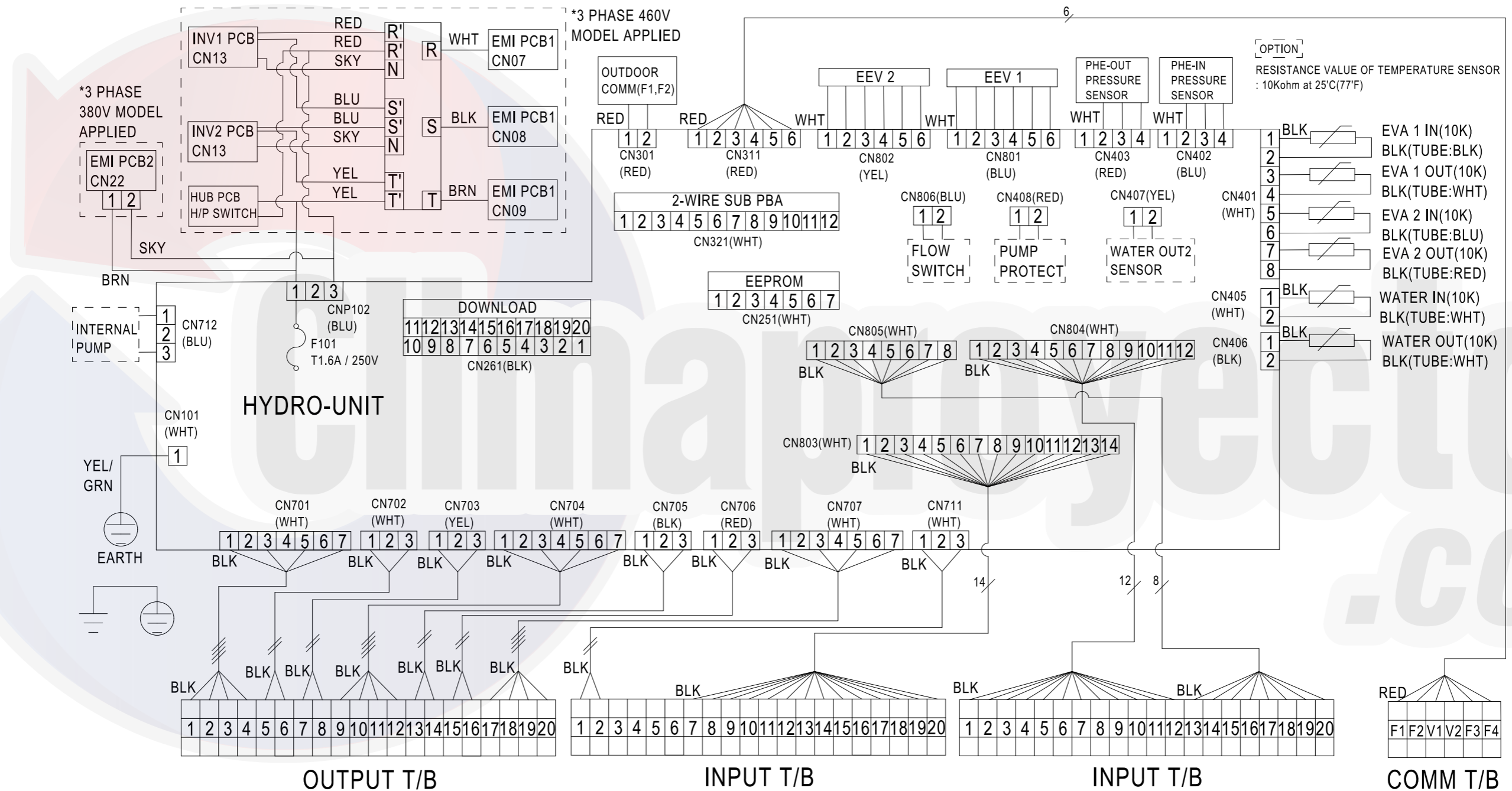

This Document can not be used without Samsung's authorization.

6-2. DVM CHILLER inverter control part wiring diagram

- Model : AG010/015KSVAF** Series

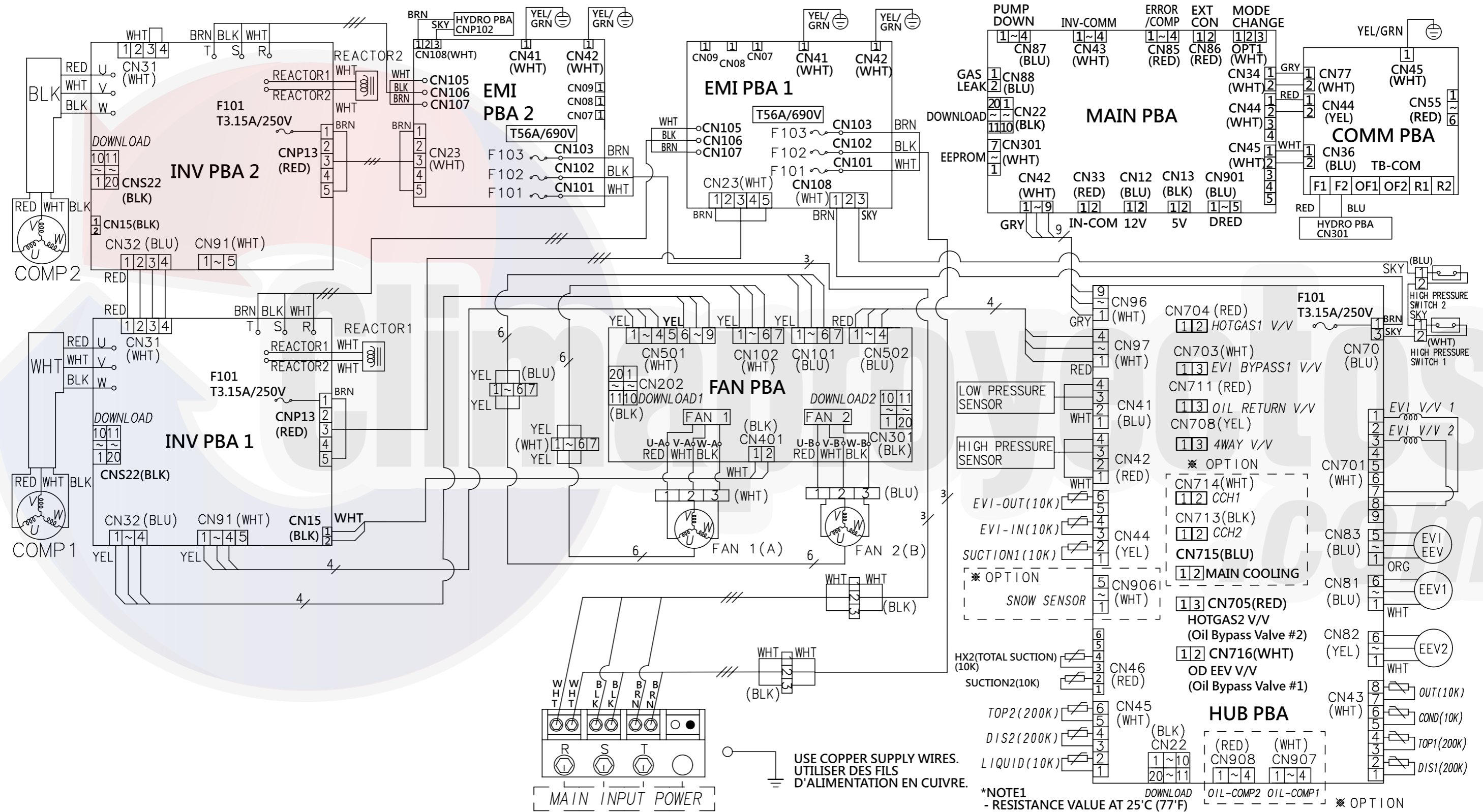

6-3. DVM CHILLER inverter control part wiring diagram

- Model : AG010/015KVAJ** Series

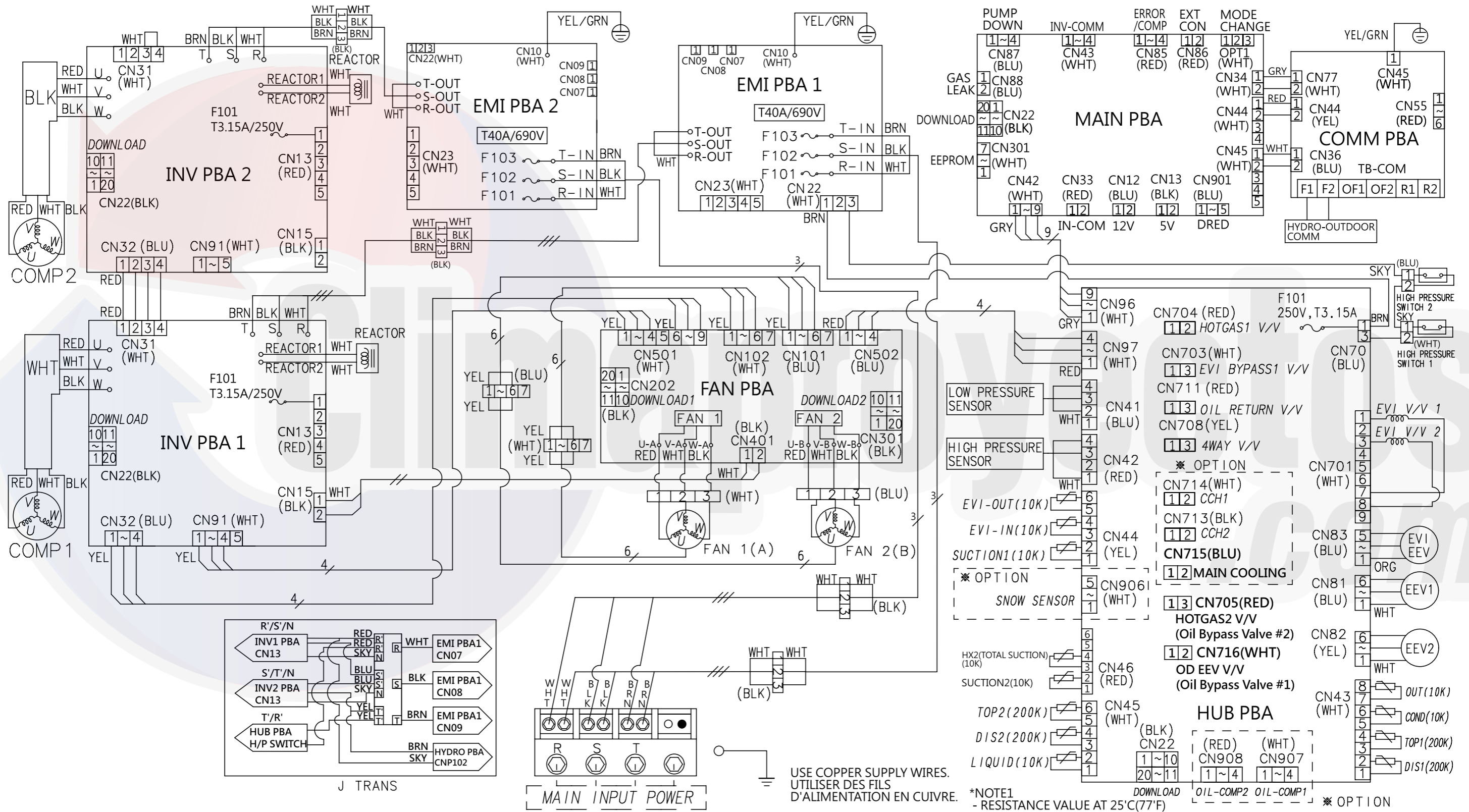

This Document can not be used without Samsung's authorization.

7. Cycle Diagram

- Model : AG010/015KSPA** Series

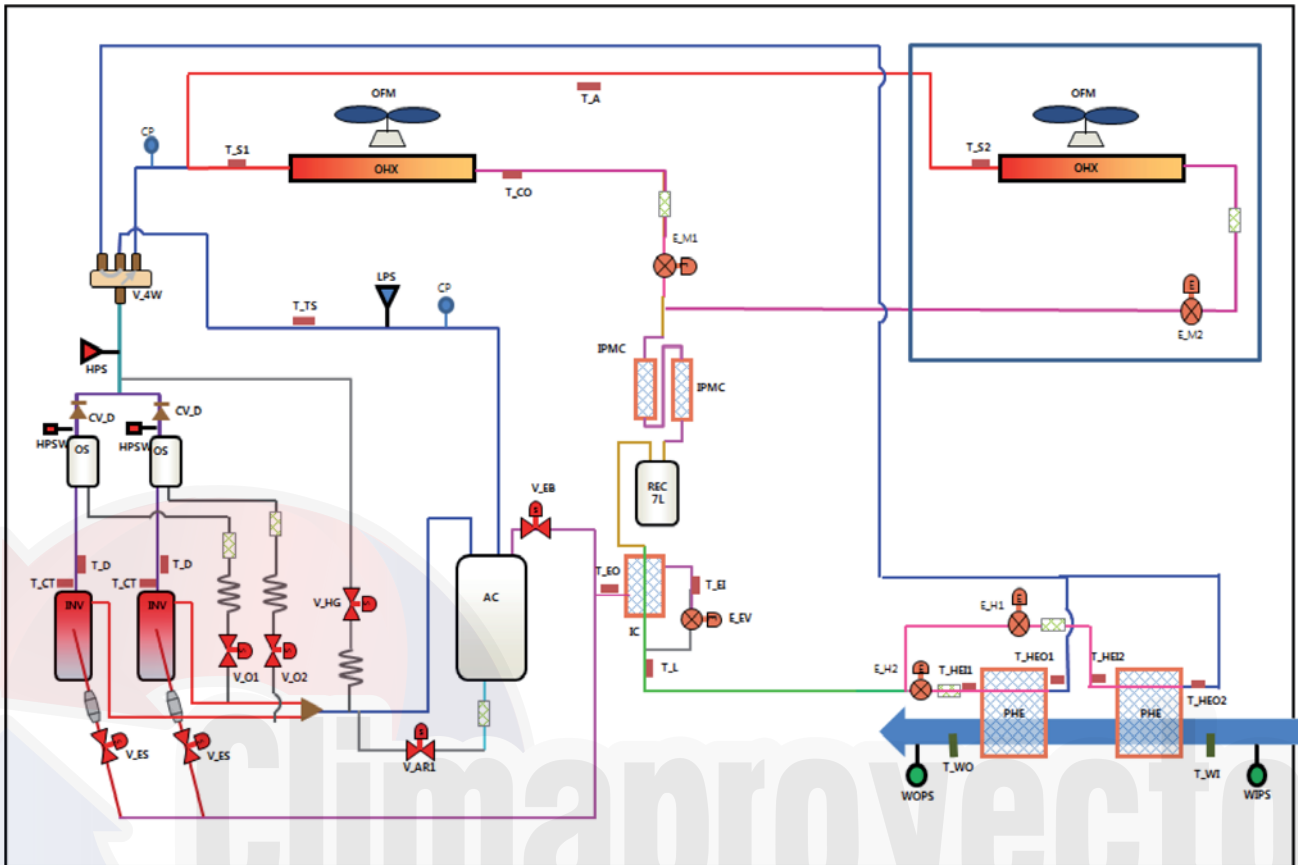

Abbreviation	Name
INV	Inverter Compressor
OFM	Outdoor Fan Motor
OHX	Outdoor Heat Exchanger
AC	Accumulator
OS	Oil Separator
IC	Intercooler
IPMC	IPM Cooler
HPS	High Pressure Sensor
LPS	Low Pressure Sensor
WIPS	Water Inlet Temperature Sensor
WOPS	Water Outlet Temperature Sensor
HPSW	High Pressure Switch
E_M1	Main EEV1
E_M2	Main EEV2
E_H1	Hydro EEV1
E_H2	Hydro EEV2
E_EV	EVI EEV
V_ES	EVI Solenoid Valve
V_EB	EVI Bypass Valve
V_O1	Oil Bypass Valve1
V_O2	Oil Bypass Valve2
PHE	Plate Heat Exchanger
REC	Receiver
CP	Charging Port
V_HG	Hot Gas Bypass Valve
V_4W	4way Valve

Abbreviation	Name
V_AR	Accumulator Oil Return Valve
CV_D	Discharge Check Valve
T_D	Discharge Temperature Sensor
T_TS	Total Suction Temperature Sensor
T_S1	Suction1 Temperature Sensor
T_S2	Suction2 Temperature Sensor
T_CO	Cond. Out Temperature Sensor
T_EI	EVI In Temperature Sensor
T_EO	EVI Out Temperature Sensor
T_L	Liquid Pipe Temperature Sensor
T_CT	Comp. Top Temperature Sensor
T_A	Ambient Temperature Sensor
T_HEI1	Hydro EVA In1 Temperature Sensor
T_HEI2	Hydro EVA In2 Temperature Sensor
T_HEO1	Hydro EVA Out1 Temperature Sensor
T_HEO2	Hydro EVA Out2 Temperature Sensor
T_WI	Water Inlet Temperature Sensor
T_WO	Water Outlet Temperature Sensor

• Cycle diagram function explanation

1. Accumulator : Separating the incoming liquid refrigerant to the compressor in order to prevent liquid refrigerant.
2. Oil Separator : Separating the oil from the refrigerant discharged from the compressor, and the separated oil is returned to the compressor.
3. Intercooler : Supercooled liquid refrigerant through the heat exchanger and makes the medium pressure gas refrigerant injected into the compressor.
4. IPM Cooler : IPM (Intelligent Power Module) by cooling to prevent overheating.
5. High/Low Pressure Sensor: Measure high/low Pressure of system.
6. High Pressure Switch : Suspend immediately for protection of system if high pressure of system exceeds setting value.
7. Outdoor EEV (Main EEV): Adjust the incoming refrigerant to the outdoor heat exchanger during heating operation.
8. EVI EEV: By adjusting the amount of refrigerant passing through the sub cooler to obtain the degree of supercooling and adjust the amount of gas refrigerant entering to the compressor.
9. 4Way Valve: Change the direction of flow of the refrigerant to the cooling / heating operation.
10. ARV (Accumulator Oil Return Valve): Remaining at the bottom of the Accumulator recovered oil to the compressor.
13. Hotgas Valve : Sending the high pressure gas to low pressure pipe in order to protect low pressure.
15. EVI SOL V : This valve opens when using the Vapor Injection.
16. EVI BYPASS V : This valve opens in the sub cooling control. It's closed when using the Vapor Injection.
17. Discharge Temp. Sensor : Measure the temperature of the refrigerant discharged from the compressor.
18. Suction Temp. Sensor : Measure the temperature of the refrigerant to the compressor suction.
19. Cond Out Temp. Sensor : Measure the temperature of the outdoor heat exchanger of the air conditioning operation.
20. EVI In/Out Temp. Sensor : Measure the temperature of the refrigerant inlet and outlet of the Sub Cooler.
21. Liquid Pipe Temperature Sensor : Measure the temperature of supercooling refrigerant in the outdoor unit of the air conditioning.
22. Comp. Top Temp. Sensor : Measure the temperature of Compressor Top Cover.
23. Ambient Temp. Sensor : Measure the outdoor temperature.
24. Receiver : Container for storing a moment before sending the liquefied refrigerant in the condenser to the expansion valve.
25. Fusible Plug : Prevent the rupture of container.
26. Water Inlet Temperature Sensor : Measuring the temperature of the water flowing into the system.
27. Water Outlet Temperature Sensor : Measuring the temperature of the water leaving the system.
28. Water Pressure Sensor : Measure the water pressure.

8. Key Options

8-1. Setting hydro controller option

Basic segment display

	SEG1	SEG2	SEG3	SEG4	SEG5	SEG6	Remarks
Water In	0	1	-	0	5	0	Ex) -5 °C

View mode display

- ▶ Press and hold K3 and K4 for 3 seconds to enter the view mode.
- ▶ Press K3 to change view mode in order of the table.
- ▶ Press K4 to change view mode in reverse order of the table.

▶ Cancelling view mode display

- Press and hold K3 for 3 seconds.

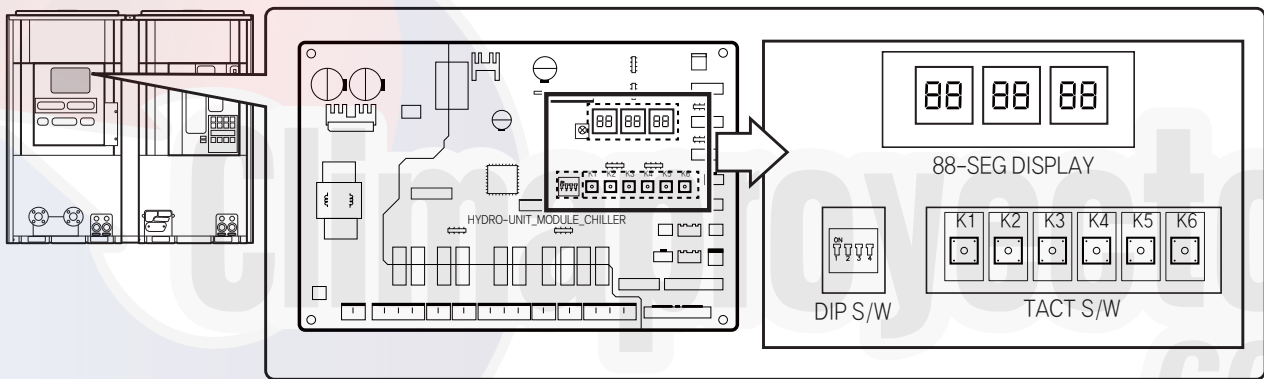

Number of press	KEY operation	SEG1	SEG2	SEG3	SEG4	SEG5	SEG6	Remarks
1 time	Water In	0	1	-	0	5	0	ex) -5 °C
2 times	Water Out	0	2	-	1	1	0	ex) -11 °C
3 times	Outdoor temperature	0	3	-	1	1	2	ex) -11.2 °C
4 times	High pressure	0	4		2	9	3	ex) 29.3 kgf/cm 2G
5 times	Low pressure	0	5		0	7	5	ex) 7.5 kgf/cm 2G
6 times	Comp 1 current frequency	0	6		1	1	0	ex) 110 Hz
7 times	Comp 2 current frequency	0	7		1	1	3	ex) 113 Hz
8 times	Discharge1 temperature	0	8		1	0	1	ex) 101.8 °C → 101(Drop)
9 times	Discharge2 temperature	0	9		1	0	1	ex) 101.8 °C → 101(Drop)
10 times	Top1 temperature	1	0		1	0	1	ex) 101.8 °C → 101(Drop)
11 times	Top2 temperature	1	1		1	0	1	ex) 101.8 °C → 101(Drop)
12 times	Total Suction temperature	1	2	-	1	1	2	ex) -11.2 °C

Number of press	KEY operation	SEG1	SEG2	SEG3	SEG4	SEG5	SEG6	Remarks
13 times	Suction1 temperature	1	3	-	1	1	2	ex) -11.2 °C
14 times	Suction2 temperature	1	4	-	1	1	2	ex) -11.2 °C
15 times	Cond out temperature	1	5	-	1	1	2	ex) -11.2 °C
16 times	Liquid temperature	1	6		3	5	0	ex) 35 °C
17 times	EVA In1 temperature	1	7		3	5	0	ex) 35 °C
18 times	EVA Out1 temperature	1	8		5	0	0	ex) 50 °C
19 times	EVA In2 temperature	1	9		3	5	0	ex) 35 °C
20 times	EVA Out2 temperature	2	0		3	5	0	ex) 35 °C
21 times	EVI In temperature	2	1		3	5	0	ex) 35 °C
22 times	EVI Out temperature	2	2		3	5	0	ex) 35 °C
23 times	IPM1 temperature	2	3		8	0	0	ex) 80 °C
24 times	IPM2 temperature	2	4		8	0	0	ex) 80 °C
25 times	CT1	2	5		1	1	0	ex) 11.0A
26 times	CT2	2	6		1	1	0	ex) 11.0A
27 times	Operation mode	2	7			Blank/S	C/H	S: Hot water/Cool storage / C: Cooling, H: Heating
28 times	Set temperature	2	8	-	0	5	0	ex) -5 °C
29 times	Pump output	2	9		0	n/F	Blank/F	On / Off
30 times	Fan Step	3	0		0	2	4	ex) 24 step
31 times	Hydro EEV1	3	1		1	0	0	ex) 1007 step → 100 (Drop "/10")
32 times	Hydro EEV2	3	2		1	0	0	ex) 1007 step → 100 (Drop "/10")
33 times	Main EEV1	3	3		1	0	0	ex) 1007 step → 100 (Drop "/10")
34 times	Main EEV2	3	4		1	0	0	ex) 1007 step → 100 (Drop "/10")
35 times	EVI EEV	3	5		4	7	3	ex) 473 step
36 times	PHE inlet pressure	3	6		0	1	2	ex) 1.2 kgf/cm ² G
37 times	PHE outlet pressure	3	7		0	0	4	ex) 0.4 kgf/cm ² G
38 times	Capacity (Cooling)	3	8		0	7	0	ex) 70 kW
39 times	(Exterior) Room temperature	3	9		2	5	5	ex) 25.5 °C
40 times	(Exterior) Water outlet temperature	4	0	-	1	1	0	ex) -11 °C
41 times	Pressure difference calibration	4	1	-	0	0	2	ex) -0.2 kgf/cm ²

8-2. How to set hydro controller option

	Option No.		Option value			
	SEG1	SEG2	SEG3	SEG4	SEG5	SEG6
Operation On/Off input method	0	1	-	-	-	0
Temperature setting input method	0	2	-	-	-	0

1. Turn on the product.
 2. Press and hold the K2 to enter the option setting.
 - In option setting, other key input (forced fan, temperature setting, etc.) is not received.
 3. Press K1 shortly to display the number for selected option.
 4. Press K2 shortly to display the number for set value of the selected option.
 5. Finish the option setting.
 - Press K2 long to finish the setting with all option values determined and saved.
 - Press K1 long to finish the setting with all option values cancelled and keep the values as before entering the setting.
- In option setting, press K4 long to initialize all option values.

No.	Option item	Option value	Factory default	Option	Definition	Setting unit	Module control setting option Note1)
1	Operation On/Off input method	0.1	0	0	Module control/DMS	Main unit of group Note2)	
				1	External contact		
2	Temperature setting input method	0.1	0	0	Module control/DMS	Main unit of group Note2)	
				1	External contact		
3	Operation mode (Cool/Heat, normal/hot water) input method	0.1	0	0	Module control/DMS	Main unit of group Note2)	
				1	External contact		
4	Demand control input method	0.1	0	0	Module control/DMS	Main unit of group Note2)	
				1	External contact		
5	Demand level	0~11	3	0	Default (100%)	Main unit of module	0
				1	95%		
				2	90%		
				3	85%		
				4	80%		
				5	75%		
				6	70%		
				7	65%		
				8	60%		
				9	55%		
				10	50%		
6	Quiet function input method	0.1	0	0	Module control/DMS	Main unit of group Note2)	
				1	External contact		
7	Forced fan function input method	0.1	0	0	Module control/DMS	Main unit of group Note2)	
				1	External contact		
8	Water law input method	0.1	0	0	Module control/DMS	Main unit of group Note2)	
				1	External contact		
9	Pump operation when thermo off	0.1	0	0	Pump OFF when thermo OFF and operation pattern is not standard control	Main unit of module	
				1	Pump ON always when thermo OFF		
10	Remote error reset input	0.1	0	0	Disuse	Main unit of module	
				1	Use		
11	Setting address of Chiller Unit - Module must be designated when it is installed. (Refer to Module-Controller Installation Manual)	0~15	0		Setting unit address	Each unit	

No.	Option item	Option value	Factory default	Option	Definition	Setting unit	Module control setting option Note1)		
12	Quiet function level	0 ~ 3	1	0	Default (100 %)	Main unit of module	0		
				1	Level1				
				2	Level2				
				3	Level3				
13	Confirm delay for unsecured flow rate when operating	10 ~ 240	30		Delay for inspecting no input for pump interlock and unsecured flow rate (by seconds)	Main unit of module			
14	Using exterior water outlet temperature sensor	0/1	0	0	Disuse	Main unit of group Note2)			
				1	Use				
15	Water law control standard	0/1	0	0	Outdoor temperature	Main unit of group Note2)			
				1	Room temperature (external room temperature sensor installation necessary)				
16	AirCool1 (For water law)	0 ~ 20	10		Standard 1 outdoor temperature for cooling	Main unit of group Note2)	0		
17	AirCool2 (For water law)	30 ~ 40	35		Standard 2 outdoor temperature for cooling				
18	RoomCool1 (For water law)	15 ~ 24	20		Standard 1 room temperature for cooling				
19	RoomCool2 (For water law)	25 ~ 35	30		Standard 2 room temperature for cooling				
20	Tcool1 (For water law)	-10 ~ 25	15		Standard 1 set temperature for cooling				
21	Tcool2 (For water law)	-10 ~ 25	7		Standard 2 set temperature for cooling				
22	AirHeat1 (For water law)	-20 ~ 5	10		Standard 1 outdoor temperature for heating				
23	AirHeat2 (For water law)	10 ~ 20	15		Standard 2 outdoor temperature for heating				
24	RoomHeat1 (For water law)	15 ~ 24	20		Standard 1 room temperature for heating				
25	RoomHeat2 (For water law)	25 ~ 35	30		Standard 2 room temperature for heating				
26	Theat1 (For water law)	35 ~ 55	45		Standard 1 set temperature for heating				
27	Theat2 (For water law)	35 ~ 55	35		Standard 2 set temperature for heating				
28	Operation ON/OFF by external contact	0/1	0	0	Recognize usual signal			Main unit of group Note2)	
				1	Recognize instant signal				
29 ~ 33	Function expansion available								
34	Using low temperature function	0/1	0	0	Disuse	Each unit			
				1	Use				
35 ~ 37	Function expansion available								

Note1) For options that can be selected by module control and main option, the option value selected for last time will be saved.

Note2) Main unit of module when group is not available

Function description

No.	Description
1	Select operation On/Off input method of module/group
2	Select temperature setting input method of module/group
3	Select operation mode (Cool/Heat, Hot water/Cool storage) input method of module/group
4	Select demand control input method of module/group
5	Select demand level • Current will be limited below the set level when "Perform" command is transmitted.
6	quiet function input method of module
7	Select forced fan function input method of module • Forced fan: Removes accumulated snow by operating the fan of stopped unit in low frequency • Snow accumulation prevention, which operates occasionally when outdoor temperature is below zero, is basic function.
8	Select water law input method of module/group
9	Select pump operation status when thermo OFF
10	Select to use error clear function by external contact
11	Setting CHILLER unit address: identical with channel address used by DMS
12	Select quiet function level • Quiet function will start in set level when "Perform" command is transmitted. • Level comparison: Level3 > Level2 > Level1
13	Confirm delay for unsecured flow rate when operating: Delay for inspecting no input for pump interlock and unsecured flow rate • Compressor will not operate until water flow is detected.
14	Set when controlling water outlet temperature by installing extra water temperature gauge on water pipe header or tank • External water outlet temperature sensor should be installed on main unit of group (or module when group is not available). • Standard for water outlet temperature depends on external water outlet temperature sensor except when operation pattern is standard control.
15	Setting water law standard • To set room temperature as standard, external room temperature sensor should be installed. • Room temperature sensor should be installed on main unit of group (or module when group is not available).
16 ~ 27	Water law control constant: Refer to water law operation graph.
28	Recognition of external control operation ON/OFF • 0 (recognizing usual signal): Constantly inspects ON/OFF status of contact and set operation ON/OFF • 1 (recognizing instant signal): Set operation ON/OFF when contact ON/OFF signal is input (when external contact is consisted of button click)
34	Select to use low temperature function • The function will operate when set simultaneously with product option of module control. (Seg23 of installation option 02 = 'E') • Low temperature function: Expands water outlet usage range in Cool/Cool storage mode. (5 ~ 25 °C (41~77 °F) → -10 ~ 25 °C (14~77 °F)) • When using low temperature function, use brine and maintain the concentration under freezing point.

Water law

This function allows water outlet temperature to change regarding demand load changes depending on outdoor temperature and room temperature. It can be set to increase energy efficiency and comfort.

- Outdoor temperature standard

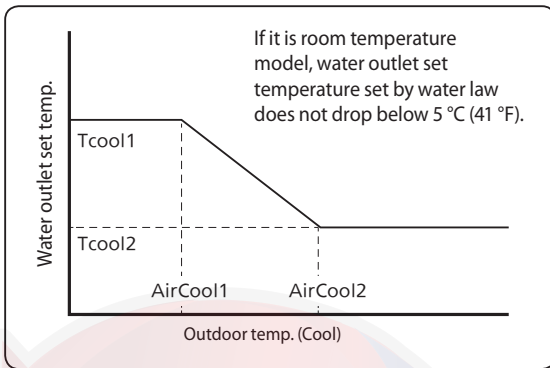

- Room temperature standard

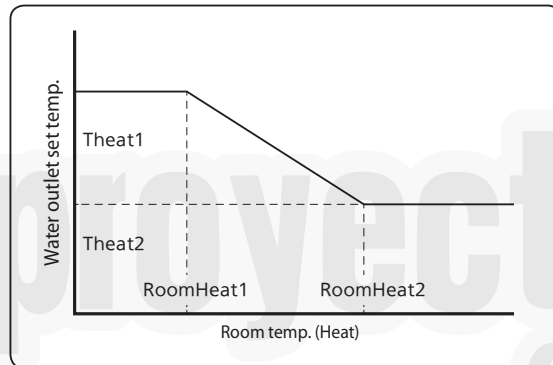
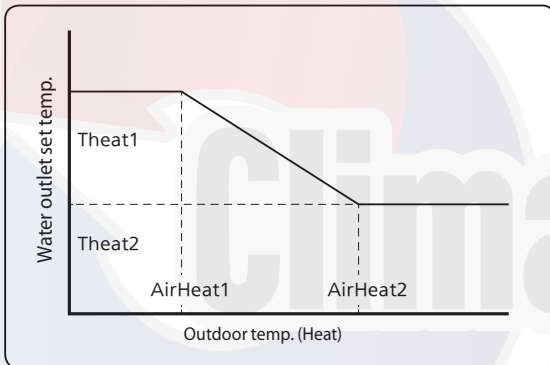
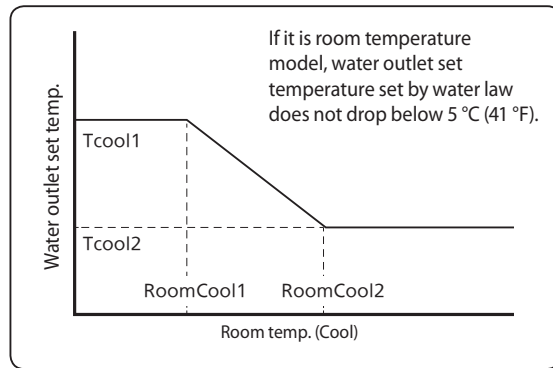

NOTE

Refer to page 125 for set values of water outlet set temperature (Tcool1, Tcool2, Theat1, Theat2), outdoor temperature (AirCool1, AirCool2, AirHeat1, AirHeat2), and room temperature (RoomCool1, RoomCool2, RoomHeat1, RoomHeat2) in the hydro controller option table No.15 ~ 27.

MICOM version display

▶ Press and hold K3 and K5 for 3 seconds to enter the view mode.

▶ Press K3 to change view mode in order of the table.

▶ Cancelling view mode display

- Press and hold K3 for 3 seconds.

	SEG1	SEG2	SEG3	SEG4	SEG5	SEG6	Remarks	Data Source
Address setting mode	0	1	0	1	1	2	Group address → 01 Module address → 01 Channel address → 12	Hydro controller
Main MICOM version	M	n	1	5	1	1	ex) ver 151101 → 1511	Inverter controller
Hub MICOM version	H	b	1	3	0	2	ex) ver 130228 → 1302	Inverter controller
Inverter 1 version	I	1	1	3	0	2	ex) ver 130228 → 1302	Inverter controller
Inverter 2	I	2	1	3	0	2	ex) ver 130228 → 1302	Inverter controller
Fan 1 version	F	1	1	3	0	2	ex) ver 130228 → 1302	Inverter controller
Fan 2 version	F	2	1	3	0	2	ex) ver 130228 → 1302	Inverter controller
EEP version	E	P	1	5	1	1	ex) ver 151101 → 1511	Inverter controller
Hydro version	H	d	1	5	1	1	ex) ver 151101 → 1511	Hydro controller

⚠ CAUTION

- Do not change settings for the unit by users.
 - Electrical wiring may be necessary. It may cause product malfunction if the option is not matching auxiliary equipment.
 - Contact the merchandise or service center to change the setting.

8-3. Setting inverter controller option

Basic segment display

Step	Display content	Display			
		SEG1	SEG2	SEG3	SEG4
At initial power input	Checking segment display	8	8	8	8
Chiller units Communicating Setting (Addressing)	-	SEG1	SEG2	SEG3, 4	SEG3, 4
		A	d	0	1
After communication setting (Usual occasion)	Transmit / Reception address	Hydro control : A	Hydro control : 0	0	0

Setting inverter controller option switch

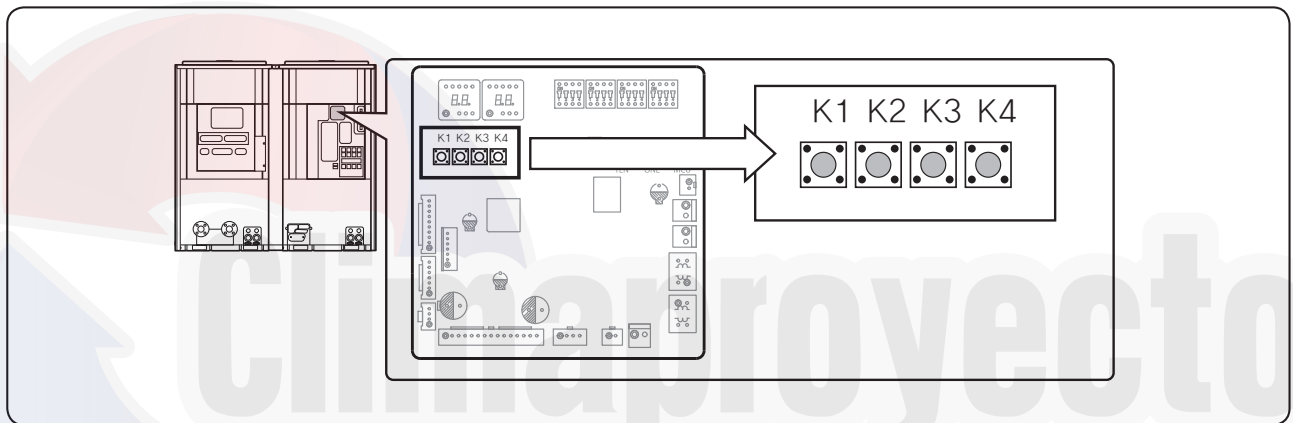

Installing and setting the option with tact switch and functions

1. Press and hold K2 for 3 seconds. (Only available when the operation is stopped)

- The display will show the following.
- If you have set the Emergency operation for compressor malfunction, 1 or 2 will be displayed on Seg 4.



- Seg 1 and Seg 2 will display the number for selected option.
- Seg 3 and Seg 4 will display the number for set value of the selected option.

2. If you have entered option setting, you can shortly press the K1 switch to change the value of the Seg 1 and Seg 2 to select desired option.

- Refer to the table for the Seg number of the function for each option.



3. If you have selected desired option, you can shortly press the K2 switch to change the value of the Seg 3 and Seg 4 to change the functional setting for the selected option.

- Refer to the table for the Seg number of the function for each option.

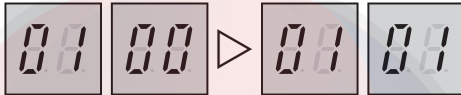

4. After selecting the function for options, press and hold the K2 switch for 2 seconds.

Entire 7-segment will blink to begin tracking mode and value of the option will be saved. If you do not end the setting mode properly, option will not be saved.

Option item	Input unit	SEG1	SEG2	SEG3	SEG4	Function of the option	Remarks
Emergency operation for compressor malfunction	Individual	0	0	0	0	Disabled	E560 will occur when all the compressors are set as malfunction state.
				0	1	Set compressor 1 as malfunction state	
				0	2	Set compressor 2 as malfunction state	
Unused option	Main	0	1	0	0	Unused option	
Unused option	Main	0	2	0	0	Unused option	
Unused option	Individual	0	3	0	0	Unused option	
Oil collection interval	Main	0	4	0	0	Factory default	
				0	1	Shorten the interval by 1/2	
Temperature to trigger defrost operation	Main	0	5	0	0	Factory default	
				0	1	Apply setting when the product is being installed in humid area such as near river or lake	
Outdoor unit fan speed correction	Individual	0	6	0	0	Factory default	
				0	1	Increase fan speed	Increase the outdoor unit fan speed to maximum value
Unused option	Main	0	7	0	0	Unused option	
Unused option	Main	0	8	0	0	Unused option	
Unused option	Main	0	9	0	0	Unused option	
Unused option	Main	1	0	0	0	Unused option	
Unused option	Main	1	1	0	0	Unused option	
Unused option	Main	1	2	0	0	Unused option	
Unused option	Main	1	3	0	0	Unused option	

Option item	Input unit	SEG1	SEG2	SEG3	SEG4	Function of the option	Remarks
Forced fan function <small>Note1)</small>	Main	1	4	0	0	Enabled (Factory default)	During snow accumulation , the fan may spin even when the unit is not in operation
				0	1	Disabled	
Unused option	Main	1	5	0	0	Unused option	
Unused option	Main	1	6	0	0	Unused option	
Unused option	Main	1	7	0	0	Unused option	
Maximum cooling capacity restriction <small>Note2)</small>	Main	1	8	0	0	Enabled	
				0	1	Disabled	
Forced fan function <small>Note1)</small>	Main	1	4	0	0	Enabled (Factory default)	During snow accumulation , the fan may spin even when the unit is not in operation
				0	1	Disabled	
Unused option	Main	1	5	0	0	Unused option	
Unused option	Main	1	6	0	0	Unused option	
Unused option	Main	1	7	0	0	Unused option	
Maximum cooling capacity restriction <small>Note2)</small>	Main	1	8	0	0	Enabled	
				0	1	Disabled	
Forced fan function <small>Note1)</small>	Main	1	4	0	0	Enabled (Factory default)	During snow accumulation , the fan may spin even when the unit is not in operation
				0	1	Disabled	
Unused option	Main	1	5	0	0	Unused option	
Unused option	Main	1	6	0	0	Unused option	
Unused option	Main	1	7	0	0	Unused option	
Maximum cooling capacity restriction <small>Note2)</small>	Main	1	8	0	0	Enabled	
				0	1	Disabled	

Note1) Forced fan function: Operates fan periodically to prevent show compiling on the fan while the product is stopped

Note2) Maximum cooling capacity restriction: Limits operation capacity of compressor according to indoor load

NOTE

- During option setting, you may press and hold the K1 for 3 seconds to reset the value to previous setting.
- If you want to restore the setting to factory default setting, press and hold the K4 for 3 seconds while you are in the option setting mode.
- If you press and hold the K4 for 3 seconds, setting will be restored to factory default setting but the setting is not saved. Press and hold the K2 for 3 seconds and when the 7-Segment enters tracking mode, setting will be saved.

How to set a special operation using tact switch and check the view mode

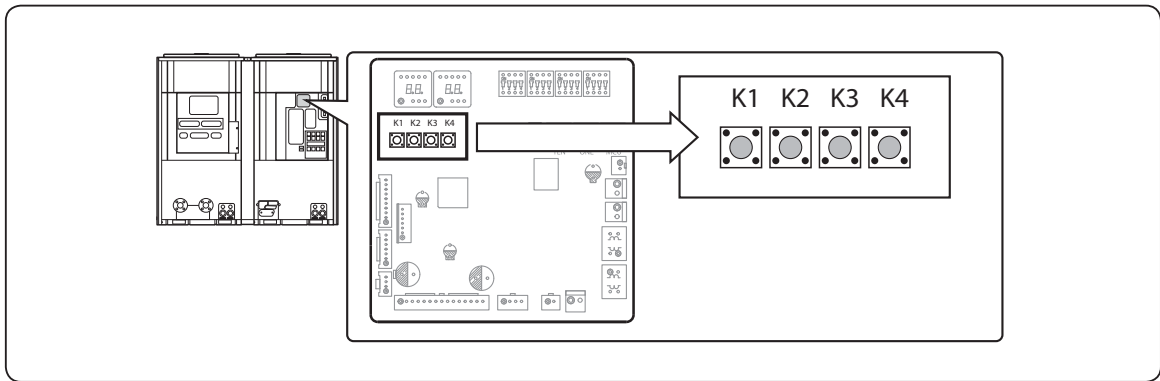

K1 (Number of press)	KEY operation	Display on 7-Segment
1times	Refrigerant charging in Heating mode	"8" "8" "8" "8"
2times	Trial operation in Heating mode	"8" "2" "8" "8"
3times	Refrigerant discharging in Heating mode	"8" "3" "8" "8"
4times	Disuse	"8" "3" "8" "2"
5times	Disuse	"8" "3" "8" "3"
6times	Disuse	"8" "3" "8" "4"
7times	Vacuum	"8" "4" "8" "8"
8times	Disuse	"8" "4" "8" "2"
9times	Disuse	"8" "4" "8" "3"
10times	Disuse	"8" "4" "8" "4"
11times	Disuse	"8" "4" "8" "8"
12times	End KEY operation	-

K2 (Number of press)	KEY operation	Display on 7-Segment
1times	Refrigerant charging in Cooling mode	"8" "5" "8" "8"
2times	Trial operation in Cooling mode	"8" "6" "8" "8"
3times	Pump down all units in Cooling mode	"8" "7" "8" "8"
4times	Auto trial operation	"8" "8" "8" "8"
5times	Checking the amount of refrigerant	"8" "5" "X" "X" (Display of last two digits may differ depending on the progress)
6times	Discharge mode of DC link voltage	"8" "8" "8" "8"
7times	Forced defrost operation	"8" "8" "8" "8"
8times	Forced oil collection	"8" "2" "8" "8"
9times	Inverter compressor 1 check	"8" "8" "8" "8"
10times	Inverter compressor 2 check	"8" "6" "8" "8"
11times	Fan 1 check	"8" "7" "8" "8"
12times	Fan 2 check	"8" "0" "8" "8"
13times	End KEY operation	-

- To use key operating function for service and maintenance when installing module/group, set as main control or cancel in module/group.
- During Discharging mode, voltage of Inv1 and Inv2 will be displayed alternately.
- Even when the power is off, it is dangerous when you come in contact with inverter PCB, fan PCB since high pressure DC voltage is charged to those parts.
- When replacing or repairing the PCB, cut-off the power and wait until the DC voltage is discharged before replacing/repairing them.
- Wait for more than 15 minutes to allow those parts to be fully discharged.
- When there is error, Discharge mode of DC link voltage may not have been effective.
Especially when E464 and E364 error is displayed, power element might be damaged so do not use the Discharge mode of DC link voltage.

K3 (Number of press)	KEY operation	Display on 7-Segment			
1 time	Intialize (Reset) operation	Same as initial state			
K4 (Number of press)	Display contents	Display			
		SEG1	SEG2, 3, 4		
1 time	Capacity depending on horsepower	1	AG010KSV*** → 0, 1, 2 AG015KSV*** → 0, 1, 8		
2 times	Order frequency (Compressor 1)	2	120 Hz → 1, 2, 0		
3 times	Order frequency (Compressor 2)	3	120 Hz → 1, 2, 0		
4 times	High pressure (MPa)	4	1.52 MPa → 1, 5, 2		
5 times	Low pressure (MPa)	5	0.43 MPa → 0, 4, 3		
6 times	Discharge temperature (Compressor 1)	6	87 °C → 0, 8, 7		
7 times	Discharge temperature (Compressor 2)	7	87 °C → 0, 8, 7		
8 times	IPM temperature (Compressor 1)	8	87 °C → 0, 8, 7		
9 times	IPM temperature (Compressor 2)	9	87 °C → 0, 8, 7		
10 times	CT sensor value (Compressor 1)	A	2 A → 0, 2, 0		
11 times	CT sensor value (Compressor 2)	B	2 A → 0, 2, 0		
12 times	Suction 1 temperature	C	-42 °C → -, 4, 2		
13 times	COND Out temperature	D	-42 °C → -, 4, 2		
14 times	Temperature of liquid pipe	E	-42 °C → -, 4, 2		
15 times	TOP temperature (Compressor 1)	F	-42 °C → -, 4, 2		
16 times	TOP temperature (Compressor 2)	G	-42 °C → -, 4, 2		
17 times	Outdoor temperature	H	-42 °C → -, 4, 2		
18 times	EVI inlet temperature	I	-42 °C → -, 4, 2		
19 times	EVI outlet temperature	J	-42 °C → -, 4, 2		
20 times	Main EEV 1 step	K	2000 steps → 2, 0, 0		
21 times	Main EEV 2 step	L	2000 steps → 2, 0, 0		
22 times	EVI EEV step	M	300 steps → 3, 0, 0		
23 times	H/R EEV step	N	300 steps → 3, 0, 0		
24 times	Fan step (SSR or BLDC)	O	13 steps → 0, 1, 3		
25 times	Current frequency (Compressor 1)	P	120 Hz → 1, 2, 0		
26 times	Current frequency (Compressor 2)	Q	120 Hz → 1, 2, 0		
27 times	Suction 2 temperature	R	-42 °C → -, 4, 2		
28 times	Master Hydro Controller address	S	Master Hydro Controller not selected → BLANK, N, D If Hydro Controller No.1 is selected as the master unit → 0, 0, 1		
29 times	Snow accumulation sensor voltage	T	1.80 V → 1, 8, 0		
30 times	Total suction temperature	U	-42 °C → -, 4, 2		
K4 (Number of press) (Press and hold the K4 for 3 seconds to enter the setting)	Display contents	Display			
		Page1	Page2		
1 time	Main version	MAIN	Version (ex.: 1412)		
2 times	Hub version	HUB	Version (ex.: 1412)		
3 times	Inverter compressor 1 check	INV1	Version (ex.: 1412)		
4 times	Inverter compressor 2 check	INV2	Version (ex.: 1412)		
5 times	Fan 1 check	FAN1	Version (ex.: 1412)		
6 times	Fan 2 check	FAN2	Version (ex.: 1412)		
7 times	EEP version	EEP	Version (ex.: 1412)		
8 times	Automatically assigned address of the units	AUTO	Seg1	Seg2	Seg3, 4
			Hydro Controller :A	Hydro Controller :0	Address (ex.: 07)
9 times	Manually assigned address of the units	MANU	Seg1	Seg2	Seg3, 4
			Hydro Controller :A	Hydro Controller :0	Address (ex.: 15)

9. Trial Operation

9-1. Trial operation for each CHILLER unit

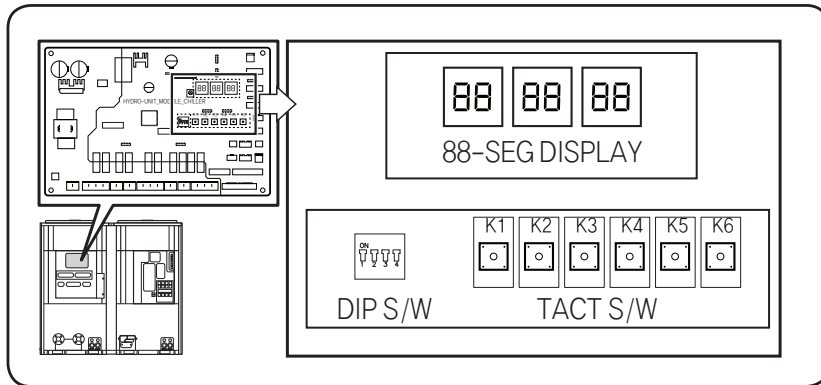

NOTE

Before a test run, check whether the power wire is disconnected or misconnected.
 If the power wire is disconnected or misconnected, error code displays or power is not supplied or major part is not operated.
 The pump built-in model is able not to operate or to be occurred trip of OCR or to reverse rotation of pump, especially if the power wire is disconnected or misconnected.

1. Turn on the product.
2. Check if DIP S/W 1 is on.

DIP S/W	No.1	
	On Main control	Off Remote control

NOTE

When set as main control, the product do not receive any control of external contact, module control, and upper controller, and any orders from module/group control.

3. Water side pressure sensor calibration

- Sensor calibration operates for more precise water rate inspection.
- It operates in main control only.
- Water flow in the system must not exist when calibrating sensor.
- Press and hold K4 and K6 for 3 seconds to start the calibration when operation of the product and the pump is off.

Seg1	Seg2	Seg3	Seg4	Seg5	Seg6
K		C	A	L	I

- The operation will finish automatically within 30 seconds.
- The product and the pump cannot be operated while calibrating the pressure difference.

4. Forced fan function removes accumulated snow on the fan. Skip this step if snow is not accumulated.

- Press and hold K6 for 3 seconds when operation is off and the fan will operate.

Seg1	Seg2	Seg3	Seg4	Seg5	Seg6
K			F	A	N

- During forced fan function, press K6 and the operation will stop.
- If the operation is on during forced fan function, the fan will stop.

5. Forced pump function checks if water flow is normal.

- Press and hold K5 for 3 seconds when operation is off and the pump will operate.

Seg1	Seg2	Seg3	Seg4	Seg5	Seg6
K		P	U	M	P

- During forced pump function, press K5 and the operation will stop.
- If the operation is on during forced pump function, the pump will stop.

6. Operation mode in main control is selected by cooling/heating switch.

DIP S/W	No.2	
	On	Off
	Cool mode	Heat mode

- Operation mode can be changed only when operation is off.

7. Change the set temperature if necessary in main control.

Default value	Cooling	Heating
	7 °C (45 °F)	45 °C (113 °F)

- Temperature can be adjusted by K3 and K4

Set temperature	K3	K4
	0.1 °C (0.18 °F) up	0.1 °C (0.18 °F) down

- Set temperature range

Set temperature range	Cooling		Heating
	On	Off	
	-10 ~ 25 °C (14~77 °F)	5 ~ 25 °C (41~77 °F)	25 ~ 55 °C (77~131 °F)

- Use brine when using in low temperature condition and maintain the concentration.

8. Operation on/off by tact switch is only possible when main control is set.

Operation mode	K1	K2
	Operation ON	Operation OFF

9. Press and hold K5 and K6 for 3 seconds to initialize hydro controller.

CAUTION

Make sure to close the top and bottom part of the product cabinet during operation.

If you operate the unit with the front cabinet open, it may cause damage to the product and you may not get the precise data from S-NET pro.

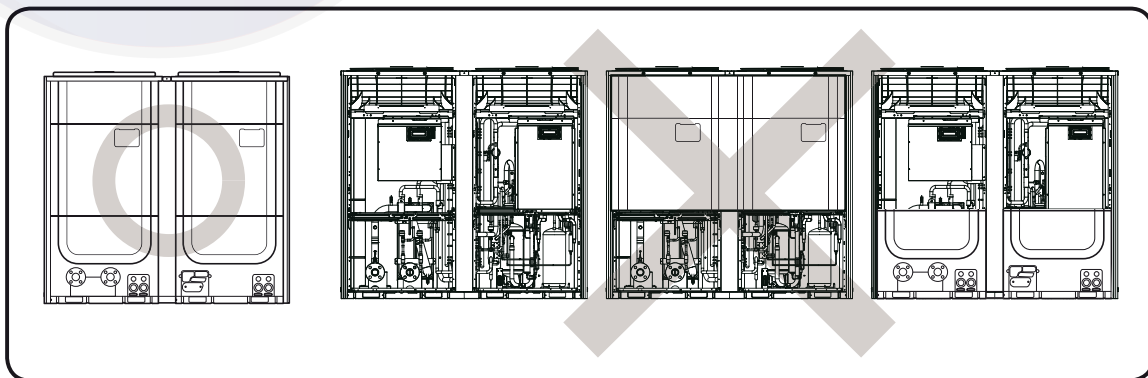

10. Reference Sheet

10-1. index of Model Name

Model Code

A	G	0	1	0	K	S	V	A	F	H	/	A	A
---	---	---	---	---	---	---	---	---	---	---	---	---	---

Capacity

Capacity	
1	BTU/H(*100)
2	CMH(*10)
3	HP(/10)
4	WATT(*100)
5	usRT

Year

Year	
E	2012
F	2013
H	2014
J	2015
K	2016
L	2017

Buyer Name

Product Type	
AM	DVM
AJ	PMA
AC	CAC (USD) / ASD
AE	EHS
AN	VTL
AK	PAK (Packaged System)
AG	CHR

Product Notation	
Code	Type
K	DVM PLUS (OUTDOOR)
V	DVM Inverter (OUTDOOR)
L	DVM SLIM (OUTDOOR)
G	DVM GHP (OUTDOOR)
M	DVM MONO (OUTDOOR)
W	DVM WATER (OUTDOOR)
C	DVM GEO (GEOTHERMAL) (OUTDOOR)
D	DVM PLUS3 (OUTDOOR)
X	DVM PLUS2 (OUTDOOR)

Power	
A	A(115V, 60hz, 1Φ)
B	B(220V, 60Hz, 1Φ)
C	C(208~230V, 60Hz)
D	D(200~220V, 50Hz)
E	E(220~240V, 50Hz)
F	F(208~230V, 60Hz, 3Φ)
G	G(380~415V, 50Hz, 3Φ)
H	H(380V, 60Hz, 3Φ)
J	J(460V, 60Hz, 3Φ)
K	K(220~240V, 50/60Hz, 1Φ)
M	M(127V, 50Hz)
N	N (380~415V, 50/60Hz, 3Φ)

Separator	
S	General Set (NASA)
N	Indoor unit (NASA)
X	Outdoor unit (NASA)
A	General Set (Non-NASA)
B	Indoor unit (Non-NASA)
C	Outdoor unit (Non-NASA)

Feature	
A	STANDARD+GENERAL Temp.+MODULE
B	STANDARD+LOW Temp.+MODULE
C	STANDARD+TROPICAL+MODULE
D	STANDARD+GENERAL Temp.+NON MODULE
E	STANDARD+LOW Temp.+NON MODULE
F	STANDARD+TROPICAL+NON MODULE
G	HIGH+GENERAL Temp.+MODULE
T	HIGH+LOW Temp.+MODULE
J	HIGH+TROPICAL+MODULE
K	HIGH+ GENERAL Temp.+NON MODULE
L	HIGH+LOW Temp.+NON MODULE
M	HIGH+TROPICAL+NON MODULE
P	STANDARD+NORDIC+MODULE
Q	HIGH+NORDIC+MODULE
N	STANDARD +PJT-BIZ+MODULE
S	FLAGSHIP+GENERAL Temp.+MODULE
H	FLAGSHIP+LOW Temp.+ MODULE
U	ULTRA+GENERAL Temp.+MODULE
R	RENEWAL+GENERAL Temp.+NON MODULE
V	PRIME+GENERAL Temp.+MODULE

Series		
C	COOLING ONLY	R410a
H	HEAT PUMP	
R	HEAT RECOVERY	
D	COOLING ONLY	R22
E	HEAT PUMP	
A	Cooling only	R134A
B	Heat Pump	
N	N/A	

※ "/" can be removed from the buyer card if there are not enough digits.



SAMSUNG

GSPN (GLOBAL SERVICE PARTNER NETWORK)

Area	Web Site
Europe, CIS, Mideast & Africa	gspn1.samsungcspportal.com
Asia	gspn2.samsungcspportal.com
North & Latin America	gspn3.samsungcspportal.com
China	china.samsungportal.com

This Service Manual is a property of Samsung Electronics Co., Ltd.
Any unauthorized use of Manual can be punished under applicable
International and/or domestic law.

© Samsung Electronics Co., Ltd. May. 2016.
Printed in Korea.
Code No. AC-00160E_1