

**38MAQ
Outdoor Unit Single Zone Ductless System
Sizes 09 to 30**



Product Data



NOTE: Image for illustration purposes only. Actual model may be slightly different.

INDUSTRY LEADING FEATURES / BENEFITS

A PERFECT BALANCE BETWEEN BUDGET LIMITS, ENERGY SAVINGS AND COMFORT.

The 38MAQ series ductless systems are a matched combination of an outdoor condensing unit and an indoor fan coil unit connected only by refrigerant tubing and wires.

The ductless system permits creative solutions to design problems such as:

- Add-ons to current space (an office or family room addition)
- Special space requirements
- When changes in the load cannot be handled by the existing system
- When adding air conditioning to spaces that are heated by hydronic or electric heat and have no ductwork
- Historical renovations or any application where preserving the look of the original structure is essential.

The ideal compliment to your ducted system when it is impractical or prohibitively expensive to use ductwork.

The compact indoor fan coil units take up very little space in the room and do not obstruct windows. The fan coils are attractively styled to blend with most room decors. Advanced system components incorporate innovative technology to provide reliable cooling performance at low sound levels.

LOW SOUND LEVELS

When noise is a concern, the ductless systems are the answer. The indoor units are whisper quiet. There are no compressors indoors, either in the conditioned space or directly over it, and there is none of the noise usually generated by air being forced through ductwork.

When sound ordinances and proximity to neighbors demand quiet operation, the 38MAQ unit is the right choice. The advanced, horizontal airflow design distributes air more evenly over the coil.

SECURE OPERATION

If security is an issue, outdoor and indoor units are connected only by refrigerant piping and wiring to prevent intruders from crawling through ductwork. In addition, since 38MAQ units can be installed close to an outside wall, coils are protected from vandals and severe weather.

FAST INSTALLATION

This compact ductless system is simple to install. A mounting bracket is standard with the indoor units and only wire and piping need to be run between the indoor and outdoor units (High Walls). These units are fast and easy to install ensuring minimal disruption to customers in the home or workplace. This makes the 38MAQ ductless systems the equipment of choice, especially in retrofit situations.

SIMPLE SERVICING AND MAINTENANCE

Removing the top panel on outdoor units provides immediate access to the control compartment, providing a service technician access to check unit operation. In addition, the draw-thru design of the outdoor section means that dirt accumulates on the outside surface of the coil. Coils can be cleaned quickly from the inside using a pressure hose and detergent.

On all indoor units, service and maintenance expense is reduced due to easy-to-use cleanable filters. In addition, these systems have extensive self-diagnostics to assist in troubleshooting.

BUILT-IN RELIABILITY

Ductless system indoor and outdoor units are designed to provide years of trouble-free operation.

The indoor units include protection against freeze-up and high evaporator temperatures on heat pumps.

The condensing units on heat pumps are protected by a three minute time delay before the compressor starts the over-current protection and the high temperature protection.

INDIVIDUAL ROOM COMFORT

Maximum comfort is provided because each space can be controlled individually based on usage pattern. The air sweep (in some indoor models) feature provided permits optimal room air mixing to eliminate hot and cold spots for occupant comfort. In addition, year-round comfort can be provided with heat pumps.

ECONOMICAL OPERATION

The ductless system design allows individual room heating or cooling when required. There is no need to run large supply-air fans or chilled water pumps to handle a few spaces with unique load patterns. In addition, because air is moved only in the space required, no energy is wasted while air moves through the ducts.

EASY-TO-USE CONTROLS

The indoor units have microprocessor-based controls to provide the ultimate in comfort and efficiency. The user friendly wireless remote control provides the interface between the user and the unit.

ACCESSORIES

Customizing these ductless systems to your application is easily accomplished.

Adding a condensate pump accessory to the indoor fan coil provides installation flexibility.

OPTIONAL WIRED CONTROLLER

AGENCY LISTINGS

All systems are listed with AHRI (Air Conditioning, Heating & Refrigeration Institute), and ETL.

MODEL NUMBER NOMENCLATURE

OUTDOOR UNIT

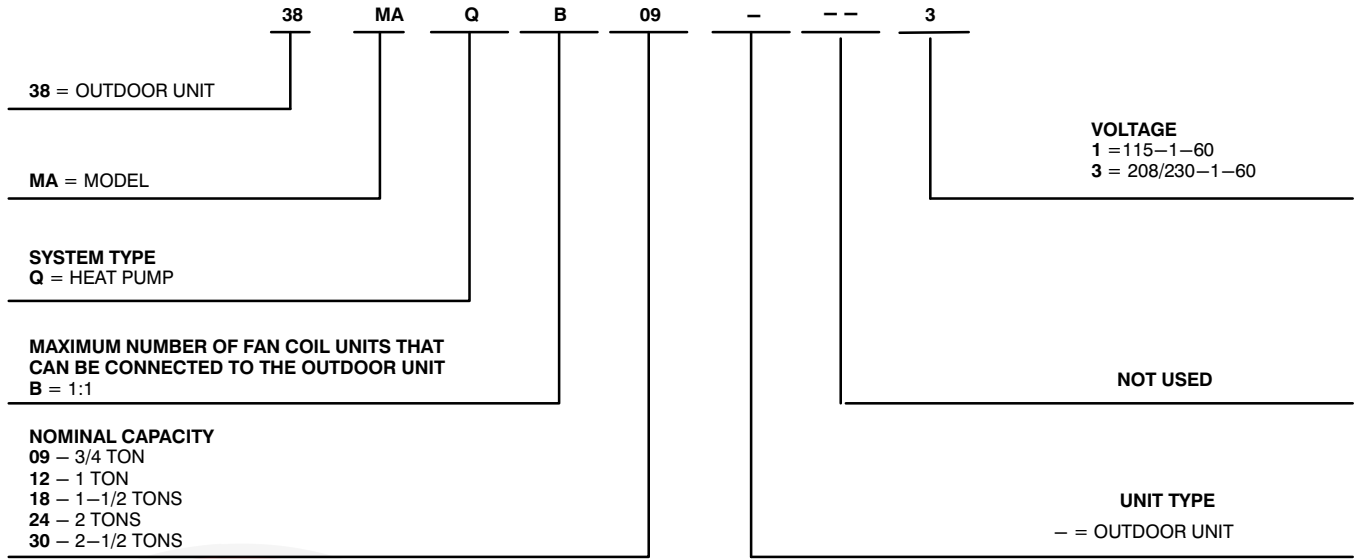

Use of the AHRI Certified TM Mark indicates a manufacturer's participation in the program. For verification of certification for individual products, go to www.ahridirectory.org.



Climaproyectos.com

STANDARD FEATURES AND ACCESSORIES

Ease Of Installation	
Low Voltage Controls	S
Energy Saving Features	
Stop/Start Timer	S
46°F Heating Mode (Heating Setback)	S
Safety And Reliability	
3 Minute Time Delay For Compressor	S
Aluminum Blue Hydrophilic pre-coated fins	S
Over Current Protection For Compressor	S
Condenser High Temp Protection in Cooling Mode	S
Ease Of Service And Maintenance	
Diagnostics	S
Liquid Line Pressure Taps	S
Application Flexibility	
Crankcase Heater	S
Base pan Heater	S

Legend

S Standard

A Accessory

OUTDOOR UNITS

Crankcase Heater

The crankcase heater is standard on all unit sizes. Heater clamps must be placed around the compressor oil stump.

Base pan Heater

The base pan heater is standard on all unit sizes.



DIMENSIONS – OUTDOOR

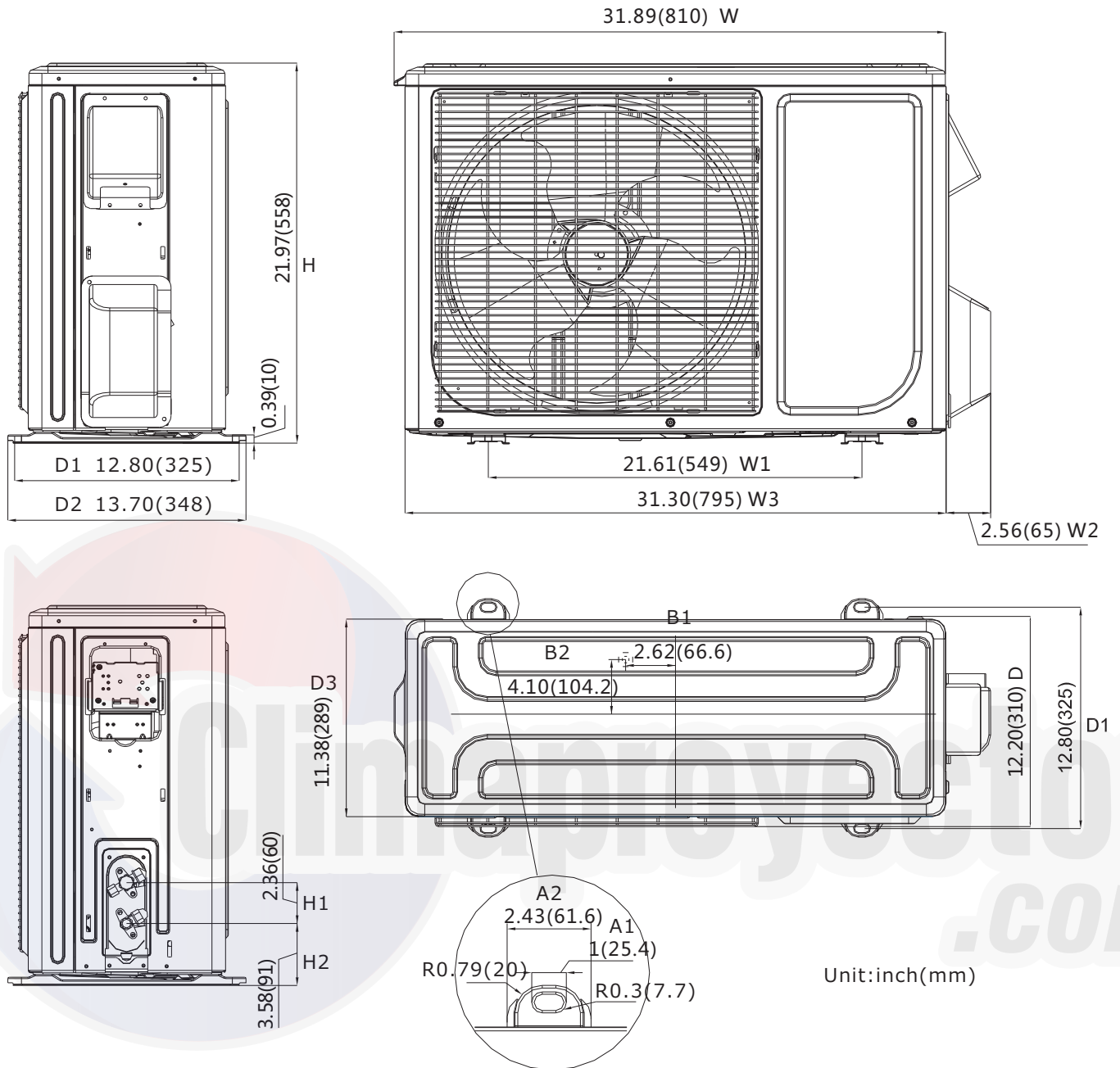

Fig. 1 – Outdoor Unit 9K and 12K

System Size		9K	12K	9K	12K
V-Ph-Hz		115-1-60		208/230-1-60	
Height (H)	in (mm)	21.97 (558)	21.97 (558)	21.97 (558)	21.97 (558)
Width (W)	in (mm)	31.89 (810)	31.89 (810)	31.89 (810)	31.89 (810)
Depth (D)	in (mm)	12.2 (310)	12.2 (310)	12.2 (310)	12.2 (310)
Weight-Net	lbs (kg)	82.45 (37.4)	82.45 (37.4)	82.45 (37.4)	82.45 (37.4)

DIMENSIONS – OUTDOOR (CONTINUED)

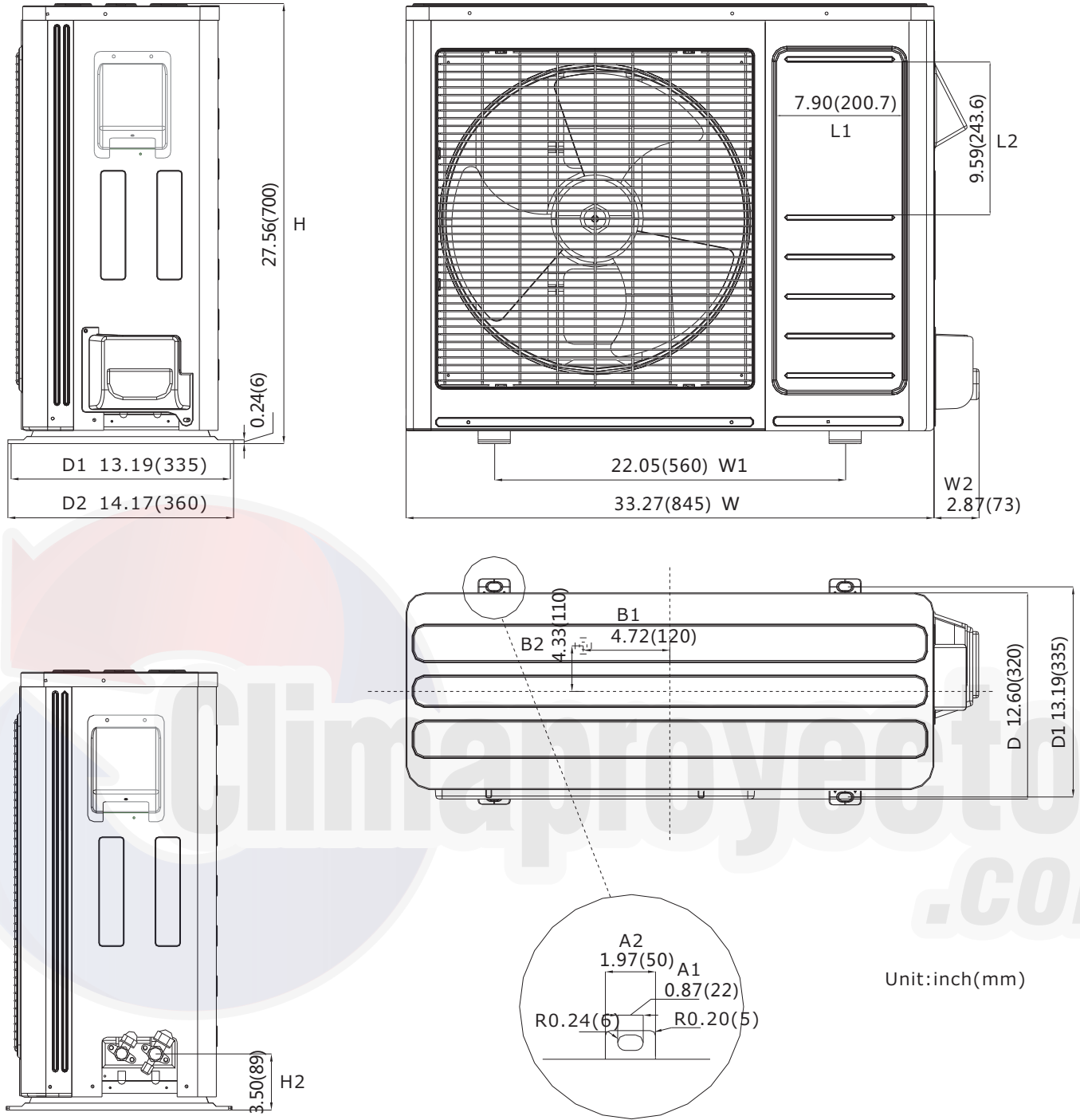

Fig. 2 – Outdoor Unit 18K

System Size		18K	
V-Ph-Hz		208/230-1-60	
Height (H)	in (mm)	27.56 (700)	
Width (W)	in (mm)	33.27 (845)	
Depth (D)	in (mm)	12.60 (320)	
Weight-Net	lbs (kg)	102.51 (46.5)	

DIMENSIONS - OUTDOOR (CONTINUED)

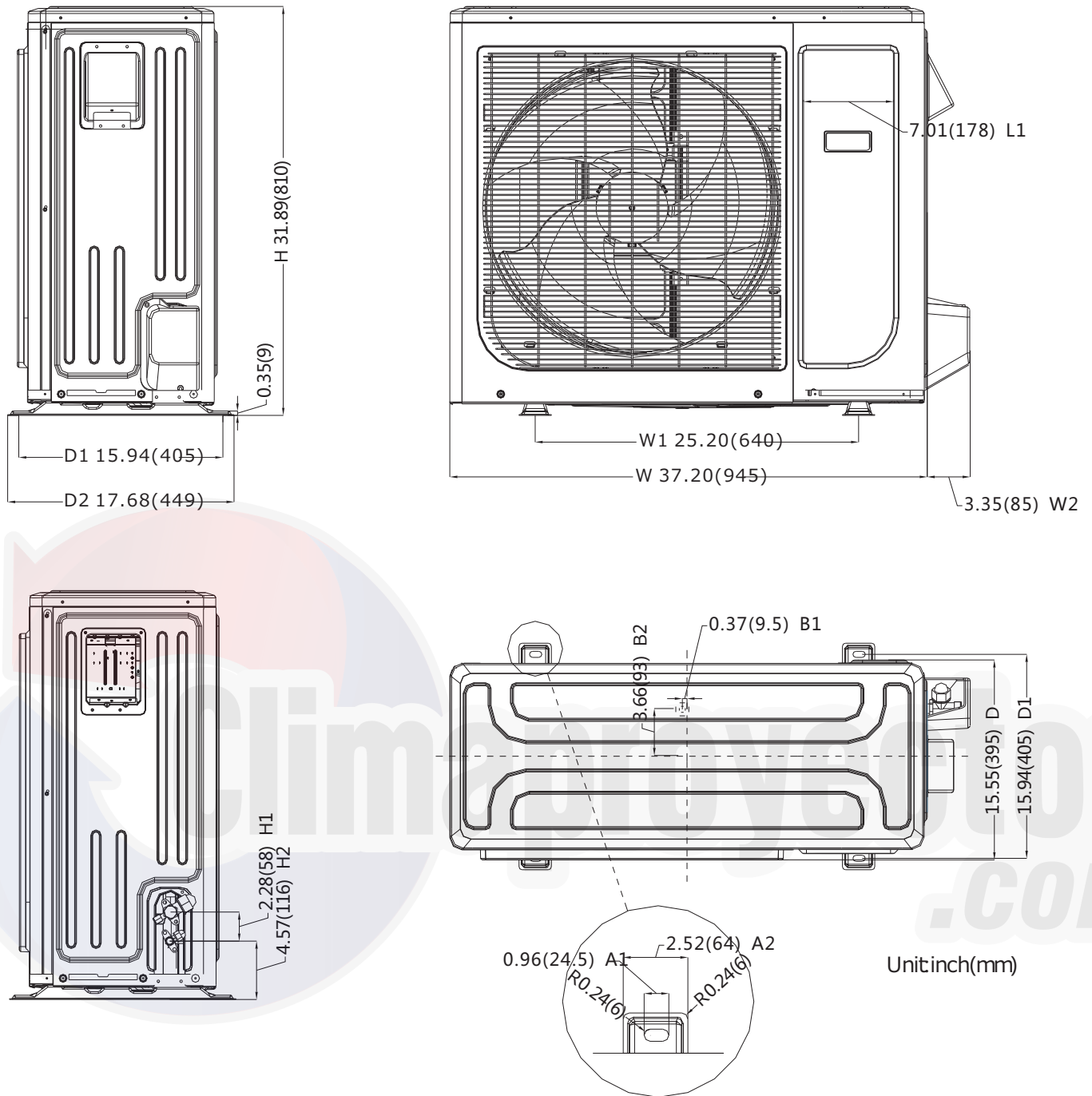

Fig. 3 – Outdoor Unit 24K & 30K

System Size		24K	30K
V-Ph-Hz		208/230-1-60	
Height (H)	in (mm)	31.89 (810)	31.89 (810)
Width (W)	in (mm)	37.20 (945)	37.20 (945)
Depth (D)	in (mm)	15.55 (395)	15.55 (395)
Weight-Net	lbs (kg)	137.57 (62.4)	157.63 (71.5)

CLEARANCES - OUTDOOR

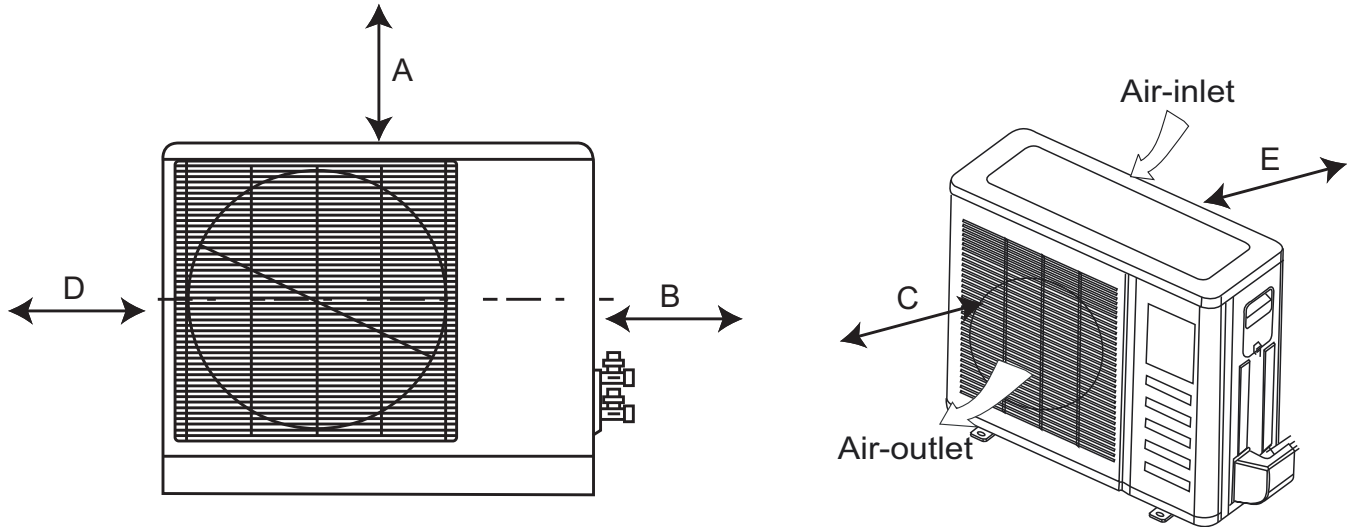
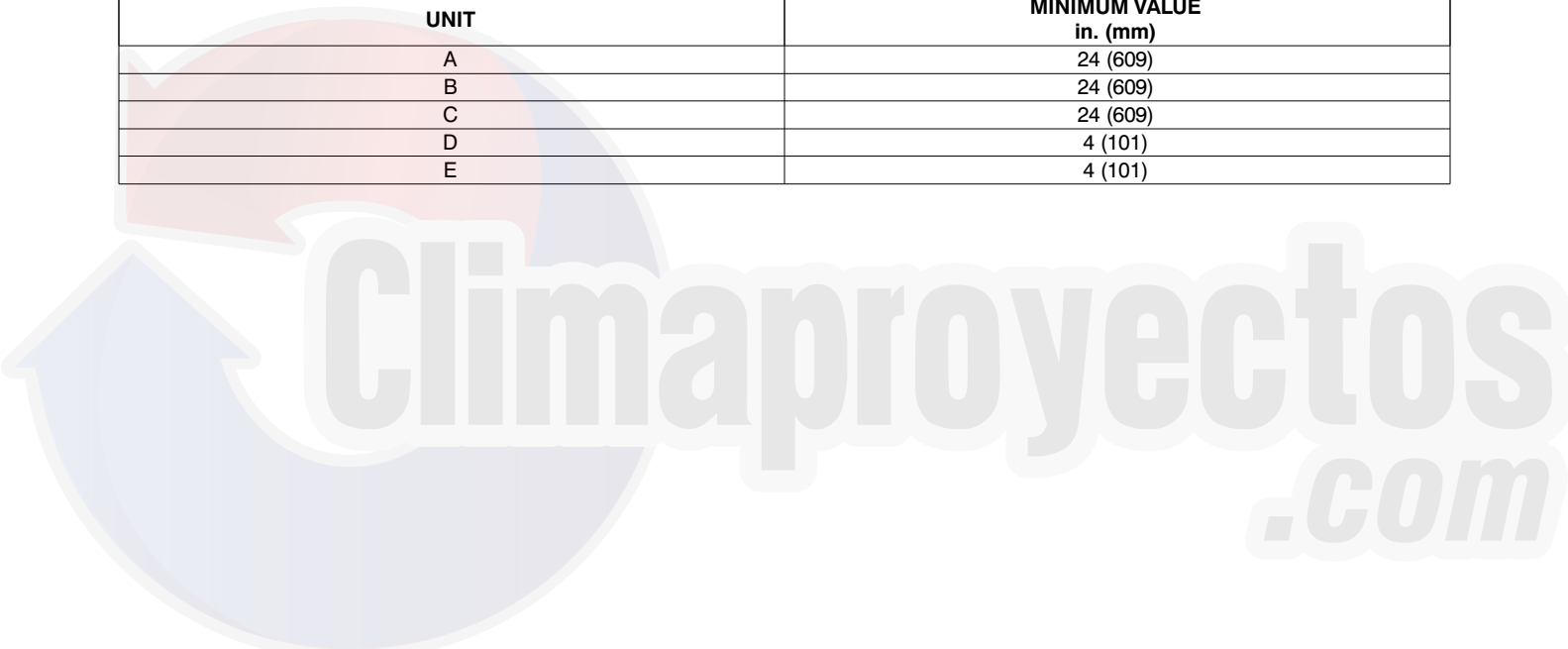

Fig. 4 - Clearances Outdoor

UNIT	MINIMUM VALUE in. (mm)
A	24 (609)
B	24 (609)
C	24 (609)
D	4 (101)
E	4 (101)



SPECIFICATIONS – OUTDOOR HEAT PUMP

System	SIZE		9	12	9	12	18	24	30
	Outdoor Model		38MAQB09---1	38MAQB12---1	38MAQB09---3	38MAQB12---3	38MAQB18---3	38MAQB24---3	38MAQB30---3
Electrical	Voltage, Phase, Cycle	V/Ph/Hz	115-1-60	115-1-60	208/230-1-60	208/230-1-60	208/230-1-60	208/230-1-60	208/230-1-60
	MCA	A.	15	15	15	15	13	15	20
	MOCP - Fuse Rating	A.	20	20	15	15	20	25	30
Operating Range	Cooling Outdoor DB Min - Max	°F (°C)	-4~122 (-20~50)	-4~122 (-20~50)	-4~122 (-20~50)	-4~122 (-20~50)	-4~122 (-20~50)	-4~122 (-20~50)	-4~122 (-20~50)
	Heating Outdoor DB Min - Max	°F (°C)	-4~86 (-20~30)	-4~86 (-20~30)	-4~86 (-20~30)	-4~86 (-20~30)	-4~86 (-20~30)	-4~86 (-20~30)	-4~86 (-20~30)
Piping	Total Piping Length	ft (m)	82 (25)	82 (25)	82 (25)	82 (25)	98 (30)	98 (30)	164 (50)
	Piping Lift	ft (m)	32 (10)	32 (10)	32 (10)	32 (10)	65 (20)	65 (20)	82 (25)
	Pipe Connection Size - Liquid	in (mm)	1/4 (6.35)	1/4 (6.35)	1/4 (6.35)	1/4 (6.35)	1/4 (6.35)	3/8 (9.52)	3/8 (9.52)
	Pipe Connection Size - Suction	in (mm)	3/8 (9.52)	1/2 (12.7)	3/8 (9.52)	1/2 (12.7)	1/2 (12.7)	5/8 (16)	5/8 (16)
Refrigerant	Type		R410A	R410A	R410A	R410A	R410A	R410A	R410A
	Charge	lbs (kg)	2.76 (1.25)	2.76 (1.25)	2.76 (1.25)	2.76 (1.25)	4.19 (1.9)	5.18 (2.35)	6.62 (3.0)
	Metering Device		EEV	EEV	EEV	EEV	EEV	Capillary Tube	Capillary Tube
Outdoor Coil	Face Area	Sq. Ft.	9.2	9.2	9.2	9.2	16.0	21.1	17.2
	No. Rows		2	2	2	2	2	3	3
	Fins per inch		21	21	21	21	18	18	17
	Circuits		4	4	4	4	6	8	6
Compressor	Type		Rotary Inverter	Rotary Inverter	Rotary Inverter	Rotary Inverter	Rotary Inverter	Rotary Inverter	Rotary Inverter
	Model		ASM98D1UFZA	ASM108D1UFZA	ASM98D1UFZA	ASM108D1UFZA	ASM135D23UFZ	DA250S2C-30MT	TNB306FPGMC-L
	Oil Type		VG74	VG74	VG74	VG74	VG74	VG74	FV50S
	Oil Charge	Fl. Oz.	12.5	12.5	12.5	12.5	15.2	27.7	36.2
	Rated Current	RLA	5.3	5.7	5.3	5.7	7.3	8.8	13.5
Outdoor	Unit Width	in (mm)	31.89 (810)	31.89 (810)	31.89 (810)	31.89 (810)	33.27 (845)	37.20 (945)	37.20 (945)
	Unit Height	in (mm)	21.97 (558)	21.97 (558)	21.97 (558)	21.97 (558)	27.56 (700)	31.89 (810)	31.89 (810)
	Unit Depth	in (mm)	12.2 (310)	12.2 (310)	12.2 (310)	12.2 (310)	12.60 (320)	15.55 (395)	15.55 (395)
	Net Weight	lbs (kg)	82.45 (37.4)	82.45 (37.4)	82.45 (37.4)	82.45 (37.4)	102.51 (46.5)	137.57 (62.4)	157.63 (71.5)
	Airflow	CFM	1,200	1,200	1,200	1,200	1,390	2,130	2,130
	Sound Pressure	dB(A)	55.5	56.0	55.5	56.0	59.0	60.0	63.0

* Condensing unit above or below indoor unit

COMPATIBILITY TABLE

INDOOR UNIT		OUTDOOR UNIT						
		38MAQB09---1	38MAQB12---1	38MAQB09---3	38MAQB12---3	38MAQB18---3	38MAQB24---3	38MAQB30---3
High Wall	40MAQB09B--1	•						
	40MAQB12B--1		•					
	40MAQB09B--3			•				
	40MAQB12B--3				•			
	40MAQB18B--3					•		
	40MAQB24B--3						•	
Cassette	40MBQB09C--3			•				
	40MBQB12C--3				•			
	40MBQB18C--3					•		
Ducted	40MBQB09D--3			•				
	40MBQB12D--3				•			
	40MBQB18D--3					•		
	40MBQB24D--3						•	
	40MBQB36D--3							•
	40MBQB48D--3							
Floor Console	40MBQB09F--3			•				
	40MBQB12F--3				•			

NOTE: Ducted Style indoor units sizes 36 and 48 NOT compatible with these outdoors.

PERFORMANCE – HIGH WALL

High Wall	Indoor Model		40MAQB09B--1	40MAQB12B--1	40MAQB09B--3	40MAQB12B--3	40MAQB18B--3	40MAQB24B--3	40MAQB30B--3
	Energy Star		YES	YES	YES	YES	YES	YES	NO
	Cooling System Tons		0.8	1.0	0.8	1.0	1.5	1.9	2.5
	Cooling Rated Capacity	Btu/h	9,000	12,000	9,000	12,000	17,500	23,000	30,000
	Cooling Cap. Range Min - Max	Btu/h	3,500~11,000	4,000~13,000	3,500~11,000	4,000~13,000	4,500~18,000	5,500~23,500	8,000~30,500
	SEER		23.5	21.5	23.5	21.5	19.5	20.0	16.5
	EER		14.5	13	14.5	13	12.5	12.5	9.5
	Heating Rated Capacity (47°F)	Btu/h	10,000	12,000	10,000	12,000	18,000	25,000	32,000
	Heating Cap. Range Min - Max	Btu/h	4,500~11,500	5,000~13,500	4,500~11,500	5,000~13,500	5,500~19,000	6,000~26,000	9,000~34,000
	HSPF		10.0	10.0	10.0	10.0	9.6	10.0	9.6
COP (47°F)		W/W	3.36	3.22	3.66	3.36	3.22	2.92	

PERFORMANCE – CASSETTE

Cassette	Indoor Model			40MBQB09C--3	40MBQB12C--3	40MBQB18C--3
	Energy Star			YES	YES	YES
	Cooling System Tons			0.8	1.0	1.3
	Cooling Rated Capacity	Btu/h		9,000	12,000	16,000
	Cooling Cap. Range Min - Max	Btu/h		3,500~11,000	4,000~13,000	4,500~18,000
	SEER			19.0	20.5	19.0
	EER			13.0	13.0	12.5
	Heating Rated Capacity (47°F)	Btu/h		10,000	12,000	18,000
	Heating Cap. Range Min - Max	Btu/h		4,500~11,500	5,000~13,500	5,500~19,000
	HSPF			10.0	10.0	9.0
COP (47°F)		W/W	3.10	3.78	3.25	

PERFORMANCE – DUCTED STYLE

Ducted	Indoor Model			40MBQB09D--3	40MBQB12D--3	40MBQB18D--3	40MBQB24D--3
	Energy Star			YES	YES	YES	YES
	Cooling System Tons			0.8	0.9	1.3	1.9
	Cooling Rated Capacity	Btu/h		9,000	11,000	16,000	23,000
	Cooling Cap. Range Min - Max	Btu/h		3,500~11,000	4,000~13,000	4,500~18,000	5,500~24,500
	SEER			19.0	18.0	18.5	19.0
	EER			13.5	12.5	12.5	12.5
	Heating Rated Capacity (47°F)	Btu/h		10,000	11,600	18,000	24,400
	Heating Cap. Range Min - Max	Btu/h		4,500~11,500	5,000~13,500	5,500~19,000	6,000~26,000
	HSPF			10.0	10.0	9.6	10.5
COP (47°F)		W/W	3.28	3.47	3.43	3.20	

PERFORMANCE – FLOOR CONSOLE

Floor Console	Indoor Model			40MBQB09F--3	40MBQB12F--3
	Energy Star			YES	YES
	Cooling System Tons			0.8	1.0
	Cooling Rated Capacity	Btu/h		9,000	12,000
	Cooling Cap. Range Min - Max	Btu/h		3,500~11,000	4,000~13,000
	SEER			20.0	20.5
	EER			12.5	12.5
	Heating Rated Capacity (47°F)	Btu/h		10,000	12,000
	Heating Cap. Range Min - Max	Btu/h		4,500~11,500	5,000~13,500
	HSPF			10	10
COP (47°F)		W/W	3.35	3.58	

COOLING PERFORMANCE DATA – HIGH WALL

MODEL	Cooling			Outdoor Conditions (DB)					
	Indoor Conditions			77F (25C)	86F (30C)	95F (35C)	104F (40C)	113F (45C)	122F (50C)
	DB	WB							
09 (115V)	69.8F(21C)	59F(15C)	TC	7.43	7.83	9.74	8.38	6.11	5.11
			SC	6.68	6.69	8.18	7.37	4.36	3.74
			Input	0.35	0.54	0.81	0.8	0.75	0.75
	75.2F(24C)	62.6F(17C)	TC	7.78	9.14	9.89	8.65	6.92	5.83
			SC	3.58	8.11	6.27	5.52	4.85	4.29
			Input	0.35	0.54	0.81	0.8	0.75	0.75
	80.6F(27C)	66.2F(19C)	TC	8.21	9.22	10.41	9.27	7.32	6
			SC	7.39	5.88	8.22	7.79	5.11	4.37
			Input	0.35	0.75	0.82	0.81	0.75	0.75
	89.6F(32C)	73.4F(23C)	TC	8.41	9.72	11.59	10.22	8.82	7.51
			SC	3.68	5.76	6.9	6.2	5.55	5
			Input	0.36	0.56	0.83	0.82	0.76	0.77
12 (115V)	69.8F(21C)	59F(15C)	TC	8.21	11.75	11.42	9	7.85	6.68
			SC	7.06	9.05	8.68	7.38	6.42	5.58
			Input	0.38	0.8	1.04	0.87	0.82	0.81
	75.2F(24C)	62.6F(17C)	TC	8.42	11.84	12.01	9.35	8.32	7.34
			SC	7.28	8.69	8.66	7.62	6.53	5.81
			Input	0.57	0.94	1.25	1.27	0.98	0.94
	80.6F(27C)	66.2F(19C)	TC	8.81	11.95	12.23	9.69	8.87	7.95
			SC	7.49	8.32	8.63	7.85	6.64	6.04
			Input	0.39	0.75	1.06	0.89	0.85	0.82
	89.6F(32C)	73.4F(23C)	TC	9.01	12.15	12.43	9.89	9.07	8.15
			SC	7.7	8.53	8.84	8.06	6.85	6.25
			Input	0.4	0.97	1.3	1.34	0.92	0.85
09 (208/230V)	69.8F(21C)	59F(15C)	TC	7.41	7.82	9.73	8.34	6.12	5.1
			SC	6.64	6.69	8.18	7.37	4.36	3.74
			Input	0.35	0.54	0.81	0.8	0.75	0.75
	75.2F(24C)	62.6F(17C)	TC	7.76	9.16	9.89	8.62	6.92	5.83
			SC	3.58	8.11	6.27	5.52	4.85	4.29
			Input	0.35	0.54	0.81	0.8	0.75	0.75
	80.6F(27C)	66.2F(19C)	TC	8.21	9.22	10.41	9.27	7.32	6
			SC	7.39	5.88	8.22	7.79	5.11	4.37
			Input	0.35	0.75	0.82	0.81	0.75	0.75
	89.6F(32C)	73.4F(23C)	TC	8.41	9.72	11.59	10.22	8.82	7.51
			SC	3.68	5.76	6.9	6.2	5.55	5
			Input	0.36	0.56	0.83	0.82	0.76	0.77
12 (208/230V)	69.8F(21C)	59F(15C)	TC	8.21	11.75	11.42	9	7.85	6.68
			SC	7.06	9.05	8.68	7.38	6.42	5.58
			Input	0.38	0.8	1.04	0.87	0.82	0.81
	75.2F(24C)	62.6F(17C)	TC	8.42	11.84	12.01	9.35	8.32	7.34
			SC	7.28	8.69	8.66	7.62	6.53	5.81
			Input	0.57	0.94	1.25	1.27	0.98	0.94
	80.6F(27C)	66.2F(19C)	TC	8.81	11.95	12.23	9.69	8.87	7.95
			SC	7.49	8.32	8.63	7.85	6.64	6.04
			Input	0.39	0.75	1.06	0.89	0.85	0.82
	89.6F(32C)	73.4F(23C)	TC	9.01	12.15	12.43	9.89	9.07	8.15
			SC	7.7	8.53	8.84	8.06	6.85	6.25
			Input	0.4	0.97	1.3	1.34	0.92	0.85
18 (208/230V)	69.8F(21C)	59F(15C)	TC	12.58	15.24	16.25	11.04	8.32	6.78
			SC	8.34	10.3	10.6	7.93	6.18	5.16
			Input	0.58	0.93	1.53	1.2	1.42	1.32
	75.2F(24C)	62.6F(17C)	TC	13.48	16.41	16.66	12.3	9.43	7.74
			SC	8.85	10.94	11.35	8.62	6.87	5.91
			Input	0.57	0.93	1.56	1.22	1.45	1.35
	80.6F(27C)	66.2F(19C)	TC	14.43	18.04	18.37	13.35	9.97	7.96
			SC	9.59	11.95	12.37	9.28	7.23	6.02
			Input	0.57	0.94	1.59	1.24	1.48	1.38
	89.6F(32C)	73.4F(23C)	TC	14.7	19.03	20.18	15.36	12.02	9.97
			SC	9.08	11.72	12.5	9.69	7.85	6.89
			Input	0.6	0.97	1.62	1.27	1.51	1.41
24 (208/230V)	69.8F(21C)	59F(15C)	TC	19.5	20.69	21.43	18.05	14.27	13.32
			SC	15.15	15.61	15.49	14.23	10.03	8.78
			Input	1.2	1.88	2.29	2.14	1.9	1.86
	75.2F(24C)	62.6F(17C)	TC	20.01	21.21	22.31	18.51	15.08	13.3
			SC	15.25	15.71	15.59	14.33	10.13	8.88
			Input	1.2	1.87	2.3	2.21	2.14	1.92
	80.6F(27C)	66.2F(19C)	TC	20.54	21.75	23.21	18.98	15.91	13.3
			SC	15.35	15.81	15.69	14.43	10.23	8.98
			Input	1.21	1.86	2.31	2.26	2.16	1.93
	89.6F(32C)	73.4F(23C)	TC	20.61	22.94	24.4	21.84	19.17	16.66
			SC	15.58	16.04	15.92	14.66	10.46	9.21
			Input	1.22	1.87	2.34	2.33	2.32	1.96
30 (208/230V)	69.8F(21C)	59F(15C)	TC	27.33	27.43	27.51	22.77	18.29	17.32
			SC	19.4	19.48	19.56	17.21	16.32	15.28
			Input	2.28	3.29	3.63	3.11	2.35	2.25
	75.2F(24C)	62.6F(17C)	TC	29.41	30.01	29.82	24.53	20.71	18.24
			SC	19.95	20.47	20.07	17.73	17.24	16.29
			Input	2.31	3.32	3.68	3.17	2.41	2.31
	80.6F(27C)	66.2F(19C)	TC	31.57	32.68	32.21	26.37	23.2	19.21
			SC	20.55	21.52	20.65	18.3	18.21	17.35
			Input	2.35	3.35	3.74	3.23	2.47	2.38
	89.6F(32C)	73.4F(23C)	TC	32.6	33.71	33.24	27.4	24.23	20.24
			SC	20.9	21.87	21	18.65	18.56	17.7
			Input	2.42	3.42	3.81	3.3	2.54	2.45

LEGEND

DB – Dry Bulb
 WB – Wet Bulb
 TC – Total Net Capacity (1000 BTU/Hr)
 SC – Sensible Capacity (1000 BTU/Hr)
 Input – Total Power (kW)

HEATING PERFORMANCE DATA – HIGH WALL

Model	Heating			Outdoor Conditions (DB)								
	Indoor Conditions DB			-4F(-20C)	0F(-17C)	5F(-15C)	17F(-8C)	19.4F(-7C)	24.8F(-4C)	32F(0C)	39.2F(4C)	44.6F(7C)
09(115V)	59F(15C)	TC	5.80	6.21	6.71	8.27	9.11	9.87	10.65	10.89	11.08	11.18
		Input	0.78	0.79	0.80	0.84	0.90	0.96	1.01	1.04	0.79	0.73
		COP	2.18	2.30	2.46	2.88	2.97	3.01	3.09	3.07	4.11	4.49
	64.4F(18C)	TC	4.60	5.02	5.46	8.01	8.84	9.63	10.54	10.65	10.82	11.06
		Input	0.80	0.81	0.82	0.90	0.94	0.98	1.03	1.08	0.80	0.78
		COP	1.69	1.82	1.95	2.61	2.76	2.88	3.00	2.89	3.96	4.15
	69F(20.5C)	TC	4.02	4.11	4.29	7.95	8.55	9.43	10.32	10.48	10.55	10.84
		Input	0.82	0.83	0.84	0.96	0.98	1.00	1.05	1.11	0.81	0.80
		COP	1.44	1.45	1.50	2.43	2.56	2.76	2.88	2.77	3.82	3.97
	71.6F(22C)	TC	3.60	3.86	4.11	7.89	8.41	9.23	10.11	10.21	10.32	10.62
		Input	0.84	0.84	0.86	0.92	1.02	1.02	1.07	1.15	0.83	0.82
		COP	1.26	1.35	1.40	2.51	2.42	2.65	2.77	2.60	3.64	3.79
12(115V)	59F(15C)	TC	4.82	5.41	5.75	8.90	9.54	10.40	11.32	12.42	12.72	11.78
		Input	0.78	0.80	0.83	0.98	1.00	1.02	1.10	1.05	1.01	0.79
		COP	1.81	1.98	2.03	2.66	2.80	2.99	3.02	3.47	3.69	4.37
	64.4F(18C)	TC	5.25	5.77	6.14	8.81	9.32	10.32	11.34	12.32	12.65	12.05
		Input	0.82	0.86	0.91	1.01	1.27	1.22	1.26	1.40	1.37	0.83
		COP	1.88	1.97	1.98	2.56	2.15	2.48	2.64	2.58	2.71	4.25
	69F(20.5C)	TC	5.45	6.05	6.49	8.43	9.12	10.21	11.32	12.12	12.60	12.27
		Input	0.86	0.92	0.98	1.03	1.25	1.19	1.19	1.12	1.10	0.83
		COP	1.86	1.93	1.94	2.40	2.14	2.51	2.79	3.17	3.36	4.33
	71.6F(22C)	TC	5.60	5.71	6.01	8.21	9.02	10.01	11.21	12.01	12.41	11.14
		Input	0.94	0.98	1.00	1.05	1.31	1.23	1.21	1.16	1.15	0.85
		COP	1.75	1.71	1.76	2.29	2.02	2.38	2.71	3.03	3.16	3.84
09 (208-230V)	59F(15C)	TC	5.80	6.21	6.71	8.27	9.11	9.87	10.65	10.89	11.08	11.18
		Input	0.78	0.79	0.80	0.84	0.90	0.96	1.01	1.04	0.79	0.73
		COP	2.18	2.30	2.46	2.88	2.97	3.01	3.09	3.07	4.11	4.49
	64.4F(18C)	TC	4.60	5.02	5.46	8.01	8.84	9.63	10.54	10.65	10.82	11.06
		Input	0.80	0.81	0.82	0.90	0.94	0.98	1.03	1.08	0.80	0.78
		COP	1.69	1.82	1.95	2.61	2.76	2.88	3.00	2.89	3.96	4.15
	69F(20.5C)	TC	4.02	4.11	4.29	7.95	8.55	9.43	10.32	10.48	10.55	10.84
		Input	0.82	0.83	0.84	0.96	0.98	1.00	1.05	1.11	0.81	0.80
		COP	1.44	1.45	1.50	2.43	2.56	2.76	2.88	2.77	3.82	3.97
	71.6F(22C)	TC	3.60	3.86	4.11	7.89	8.41	9.23	10.11	10.21	10.32	10.62
		Input	0.84	0.84	0.86	0.92	1.02	1.02	1.07	1.15	0.83	0.82
		COP	1.26	1.35	1.40	2.51	2.42	2.65	2.77	2.60	3.64	3.79
12 (208-230V)	59F(15C)	TC	4.82	5.41	5.75	8.90	9.54	10.40	11.32	12.42	12.72	11.78
		Input	0.78	0.80	0.83	0.98	1.00	1.02	1.10	1.05	1.01	0.79
		COP	1.81	1.98	2.03	2.66	2.80	2.99	3.02	3.47	3.69	4.37
	64.4F(18C)	TC	5.25	5.77	6.14	8.81	9.32	10.32	11.34	12.32	12.65	12.05
		Input	0.82	0.86	0.91	1.01	1.27	1.22	1.26	1.40	1.37	0.83
		COP	1.88	1.97	1.98	2.56	2.15	2.48	2.64	2.58	2.71	4.25
	69F(20.5C)	TC	5.45	6.05	6.49	8.43	9.12	10.21	11.32	12.12	12.60	12.27
		Input	0.86	0.92	0.98	1.03	1.25	1.19	1.19	1.12	1.10	0.83
		COP	1.86	1.93	1.94	2.40	2.14	2.51	2.79	3.17	3.36	4.33
	71.6F(22C)	TC	5.60	5.71	6.01	8.21	9.02	10.01	11.21	12.01	12.41	11.14
		Input	0.94	0.98	1.00	1.05	1.31	1.23	1.21	1.16	1.15	0.85
		COP	1.75	1.71	1.76	2.29	2.02	2.38	2.71	3.03	3.16	3.84
18 (208-230V)	59F(15C)	TC	8.02	8.73	9.39	12.08	14.28	16.52	17.56	19.42	20.54	23.16
		Input	1.16	1.19	1.21	1.35	1.40	1.46	1.58	1.48	1.49	1.58
		COP	2.03	2.15	2.27	2.62	2.99	3.32	3.26	3.84	4.04	4.29
	64.4F(18C)	TC	7.86	8.44	9.16	12.06	13.94	16.05	16.89	18.66	20.08	22.41
		Input	1.20	1.24	1.29	1.40	1.45	1.52	1.61	1.55	1.55	1.62
		COP	1.92	1.99	2.08	2.52	2.82	3.09	3.07	3.53	3.80	4.05
	69F(20.5C)	TC	7.62	8.33	8.95	12.07	13.62	15.62	16.26	17.93	19.67	21.71
		Input	1.31	1.32	1.38	1.45	1.50	1.58	1.65	1.63	1.62	1.67
		COP	1.70	1.85	1.90	2.44	2.66	2.90	2.89	3.22	3.56	3.81
	71.6F(22C)	TC	7.01	7.66	8.25	11.37	12.92	14.92	15.56	17.23	18.97	21.01
		Input	1.34	1.39	1.43	1.50	1.55	1.63	1.70	1.68	1.67	1.72
		COP	1.53	1.62	1.69	2.22	2.44	2.68	2.68	3.00	3.33	3.58
24 (208-230V)	59F(15C)	TC	15.21	17.01	18.93	23.16	23.22	23.42	23.56	25.85	27.79	28.60
		Input	2.15	2.15	2.17	2.24	2.23	2.20	2.21	2.24	2.25	2.00
		COP	2.07	2.32	2.56	3.03	3.05	3.12	3.12	3.38	3.62	4.19
	64.4F(18C)	TC	14.32	15.81	17.45	20.45	22.52	23.40	23.54	24.52	27.61	27.62
		Input	2.13	2.14	2.16	2.21	2.23	2.32	2.35	2.35	2.45	2.24
		COP	1.97	2.17	2.37	2.71	2.96	2.96	2.93	3.06	3.30	3.61
	69F(20.5C)	TC	13.21	13.77	16.38	19.61	21.85	22.98	24.63	26.75	29.25	29.09
		Input	2.16	2.16	2.18	2.20	2.25	2.42	2.58	2.64	2.74	2.39
		COP	1.79	1.87	2.20	2.61	2.85	2.78	2.80	2.97	3.13	3.57
	71.6F(22C)	TC	13.01	14.66	16.24	19.54	21.67	22.54	23.41	24.21	27.52	26.87
		Input	2.12	2.13	2.17	2.24	2.23	2.20	2.21	2.24	2.25	2.00
		COP	1.80	2.02	2.19	2.56	2.85	3.00	3.10	3.17	3.58	3.94
30 (208-230V)	59F(15C)	TC	16.25	18.44	20.51	28.84	30.65	32.32	34.65	37.52	41.17	42.96
		Input	2.51	2.53	2.61	2.82	2.96	3.20	3.43	3.69	3.99	3.79
		COP	1.90	2.14	2.30	3.00	3.03	2.96	2.96	2.98	3.02	3.32
	64.4F(18C)	TC	15.21	18.02	19.96	26.47	28.58	30.95	33.84	36.55	39.86	39.63
		Input	2.56	2.66	2.76	3.04	3.11	3.24	3.65	3.85	4.23	3.35
		COP	1.74	1.99	2.12	2.55	2.69	2.80	2.72	2.78	2.76	3.47
	69F(20.5C)	TC	14.32	16.81	19.43	24.13	26.54	29.62	33.07	35.62	38.58	36.33
		Input	2.75	2.81	2.89	3.16	3.20	3.31	3.90	4.01	4.46	3.45
		COP	1.53	1.75	1.97	2.24	2.43	2.62	2.48	2.60	2.53	3.09
	71.6F(22C)	TC	13.85	14.91	16.03	20.73	23.14	26.22	29.67	32.22	35.18	32.93
		Input	2.84	2.99	3.12	3.39	3.43	3.54	4.13	4.24	4.69	3.68
		COP	1.43	1.46	1.51	1.79	1.98	2.17	2.10	2.23	2.20	2.62

LEGEND

DB – Dry Bulb
 WB – Wet Bulb
 TC – Total Net Capacity (1000 BTU/Hr)
 COP – Coefficient of Performance (W/W)
 Input – Total Power (kW)

COOLING PERFORMANCE DATA – CASSETTE, DUCTED STYLE, FLOOR CONSOLE

Model	Cooling			Outdoor Conditions (DB)					
	Indoor Conditions DB			77F(25C)	86F(30C)	95F(35C)	104F(40C)	113F(45C)	122F(50C)
	DB	WB							
9	69.8F(21C)	59F(15C)	TC	7.41	7.82	9.73	8.34	6.12	5.10
			SC	6.64	6.69	8.18	7.37	4.36	3.74
			Input	0.35	0.54	0.81	0.80	0.75	0.75
	75.2F(24C)	62.6F(17C)	TC	7.76	9.16	9.89	8.62	6.92	5.83
			SC	3.58	8.11	6.27	5.52	4.85	4.29
			Input	0.35	0.54	0.81	0.80	0.75	0.75
	80.6F(27C)	66.2F(19C)	TC	8.21	9.22	10.41	9.27	7.32	6.00
			SC	7.39	5.88	8.22	7.79	5.11	4.37
			Input	0.35	0.75	0.82	0.81	0.75	0.75
	89.6F(32C)	73.4F(23C)	TC	8.41	9.72	11.59	10.22	8.82	7.51
			SC	3.68	5.76	6.90	6.20	5.55	5.00
			Input	0.36	0.56	0.83	0.82	0.76	0.77
12	69.8F(21C)	59F(15C)	TC	8.21	11.75	11.42	9.00	7.85	6.68
			SC	7.06	9.05	8.68	7.38	6.42	5.58
			Input	0.38	0.80	1.04	0.87	0.82	0.81
	75.2F(24C)	62.6F(17C)	TC	8.42	11.84	12.01	9.35	8.32	7.34
			SC	7.28	8.69	8.66	7.62	6.53	5.81
			Input	0.57	0.94	1.25	1.27	0.98	0.94
	80.6F(27C)	66.2F(19C)	TC	8.81	11.95	12.23	9.69	8.87	7.95
			SC	7.49	8.32	8.63	7.85	6.64	6.04
			Input	0.39	0.75	1.06	0.89	0.85	0.82
	89.6F(32C)	73.4F(23C)	TC	9.01	12.15	12.43	9.89	9.07	8.15
			SC	7.70	8.53	8.84	8.06	6.85	6.25
			Input	0.40	0.97	1.30	1.34	0.92	0.85
18	69.8F(21C)	59F(15C)	TC	12.58	15.24	16.25	11.04	8.32	6.78
			SC	8.34	10.30	10.60	7.93	6.18	5.16
			Input	0.58	0.93	1.53	1.20	1.42	1.32
	75.2F(24C)	62.6F(17C)	TC	13.48	16.41	16.66	12.30	9.43	7.74
			SC	8.85	10.94	11.35	8.62	6.87	5.91
			Input	0.57	0.93	1.56	1.22	1.45	1.35
	80.6F(27C)	66.2F(19C)	TC	14.43	18.04	18.37	13.35	9.97	7.96
			SC	9.59	11.95	12.37	9.28	7.23	6.02
			Input	0.57	0.94	1.59	1.24	1.48	1.38
	89.6F(32C)	73.4F(23C)	TC	14.70	19.03	20.18	15.36	12.02	9.97
			SC	9.08	11.72	12.50	9.69	7.85	6.89
			Input	0.60	0.97	1.62	1.27	1.51	1.41
24	69.8F(21C)	59F(15C)	TC	19.50	20.69	21.43	18.05	14.27	13.32
			SC	15.15	15.61	15.49	14.23	10.03	8.78
			Input	1.20	1.88	2.29	2.14	1.90	1.86
	75.2F(24C)	62.6F(17C)	TC	20.01	21.21	22.31	18.51	15.08	13.30
			SC	15.25	15.71	15.59	14.33	10.13	8.88
			Input	1.20	1.87	2.30	2.21	2.14	1.92
	80.6F(27C)	66.2F(19C)	TC	20.54	21.75	23.21	18.98	15.91	13.30
			SC	15.35	15.81	15.69	14.43	10.23	8.98
			Input	1.21	1.86	2.31	2.26	2.16	1.93
	89.6F(32C)	73.4F(23C)	TC	20.61	22.94	24.40	21.84	19.17	16.66
			SC	15.58	16.04	15.92	14.66	10.46	9.21
			Input	1.22	1.87	2.34	2.33	2.32	1.96

LEGEND

DB – Dry Bulb
 WB – Wet Bulb
 TC – Total Net Capacity (1000 Btu/hour)
 SC – Sensible Capacity (1000 Btu/hour)
 Input – Total Power (kW)

HEATING PERFORMANCE DATA – CASSETTE, DUCTED STYLE, FLOOR CONSOLE

Model	Heating			Outdoor Conditions (DB)								
	Indoor Conditions (DB)	-4F(-20C)	0F(-17C)	5F(-15C)	17F(-8C)	19.4F(-7C)	24.8F(-4C)	32F(0C)	39.2F(4C)	44.6F(7C)	53.6F(12C)	
9	59F(15C)	TC	5.80	6.21	6.71	8.27	9.11	9.87	10.65	10.89	11.08	11.18
		Input	0.78	0.79	0.80	0.84	0.90	0.96	1.01	1.04	0.79	0.73
		COP	2.18	2.30	2.46	2.88	2.97	3.01	3.09	3.07	4.11	4.49
	64.4F(18C)	TC	4.60	5.02	5.46	8.01	8.84	9.63	10.54	10.65	10.82	11.06
		Input	0.80	0.81	0.82	0.90	0.94	0.98	1.03	1.08	0.80	0.78
		COP	1.69	1.82	1.95	2.61	2.76	2.88	3.00	2.89	3.96	4.15
	69F(20.5C)	TC	4.02	4.11	4.29	7.95	8.55	9.43	10.32	10.48	10.55	10.84
		Input	0.82	0.83	0.84	0.96	0.98	1.00	1.05	1.11	0.81	0.80
		COP	1.44	1.45	1.50	2.43	2.56	2.76	2.88	2.77	3.82	3.97
	71.6F(22C)	TC	3.60	3.86	4.11	7.89	8.41	9.23	10.11	10.21	10.32	10.62
		Input	0.84	0.84	0.86	0.92	1.02	1.02	1.07	1.15	0.83	0.82
		COP	1.26	1.35	1.40	2.51	2.42	2.65	2.77	2.60	3.64	3.79
12	59F(15C)	TC	4.82	5.41	5.75	8.90	9.54	10.40	11.32	12.42	12.72	11.78
		Input	0.78	0.80	0.83	0.98	1.00	1.02	1.10	1.05	1.01	0.79
		COP	1.81	1.98	2.03	2.66	2.80	2.99	3.02	3.47	3.69	4.37
	64.4F(18C)	TC	5.25	5.77	6.14	8.81	9.32	10.32	11.34	12.32	12.65	12.05
		Input	0.82	0.86	0.91	1.01	1.27	1.22	1.26	1.40	1.37	0.83
		COP	1.88	1.97	1.98	2.56	2.15	2.48	2.64	2.58	2.71	4.25
	69F(20.5C)	TC	5.45	6.05	6.49	8.43	9.12	10.21	11.32	12.12	12.60	12.27
		Input	0.86	0.92	0.98	1.03	1.25	1.19	1.19	1.12	1.10	0.83
		COP	1.86	1.93	1.94	2.40	2.14	2.51	2.79	3.17	3.36	4.33
	71.6F(22C)	TC	5.60	5.71	6.01	8.21	9.02	10.01	11.21	12.01	12.41	11.14
		Input	0.94	0.98	1.00	1.05	1.31	1.23	1.21	1.16	1.15	0.85
		COP	1.75	1.71	1.76	2.29	2.02	2.38	2.71	3.03	3.16	3.84
18	59F(15C)	TC	8.02	8.73	9.39	12.08	14.28	16.52	17.56	19.42	20.54	23.16
		Input	1.16	1.19	1.21	1.35	1.40	1.46	1.58	1.48	1.49	1.58
		COP	2.03	2.15	2.27	2.62	2.99	3.32	3.26	3.84	4.04	4.29
	64.4F(18C)	TC	7.86	8.44	9.16	12.06	13.94	16.05	16.89	18.66	20.08	22.41
		Input	1.20	1.24	1.29	1.40	1.45	1.52	1.61	1.55	1.55	1.62
		COP	1.92	1.99	2.08	2.52	2.82	3.09	3.07	3.53	3.80	4.05
	69F(20.5C)	TC	7.62	8.33	8.95	12.07	13.62	15.62	16.26	17.93	19.67	21.71
		Input	1.31	1.32	1.38	1.45	1.50	1.58	1.65	1.63	1.62	1.67
		COP	1.70	1.85	1.90	2.44	2.66	2.90	2.89	3.22	3.56	3.81
	71.6F(22C)	TC	7.01	7.66	8.25	11.37	12.92	14.92	15.56	17.23	18.97	21.01
		Input	1.34	1.39	1.43	1.50	1.55	1.63	1.70	1.68	1.67	1.72
		COP	1.53	1.62	1.69	2.22	2.44	2.68	2.68	3.00	3.33	3.58
24	59F(15C)	TC	15.21	17.01	18.93	23.16	23.22	23.42	23.56	25.85	27.79	28.60
		Input	2.15	2.15	2.17	2.24	2.23	2.20	2.21	2.24	2.25	2.00
		COP	2.07	2.32	2.56	3.03	3.05	3.12	3.12	3.38	3.62	4.19
	64.4F(18C)	TC	14.32	15.81	17.45	20.45	22.52	23.40	23.54	24.52	27.61	27.62
		Input	2.13	2.14	2.16	2.21	2.23	2.32	2.35	2.35	2.45	2.24
		COP	1.97	2.17	2.37	2.71	2.96	2.96	2.93	3.06	3.30	3.61
	69F(20.5C)	TC	13.21	13.77	16.38	19.61	21.85	22.98	24.63	26.75	29.25	29.09
		Input	2.16	2.16	2.18	2.20	2.25	2.42	2.58	2.64	2.74	2.39
		COP	1.79	1.87	2.20	2.61	2.85	2.78	2.80	2.97	3.13	3.57
	71.6F(22C)	TC	13.01	14.66	16.24	19.54	21.67	22.54	23.41	24.21	27.52	26.87
		Input	2.12	2.13	2.17	2.24	2.23	2.20	2.21	2.24	2.25	2.00
		COP	1.80	2.02	2.19	2.56	2.85	3.00	3.10	3.17	3.58	3.94

LEGEND

DB – Dry Bulb
 TC – Total Net Capacity (1000 Btu/hour)
 COP – Coefficient of Performance (W/W)
 Input – Total Power (1000 W)

APPLICATION DATA

UNIT SELECTION

Select equipment that either matches or supports slightly more than the anticipated peak load. This provides better humidity control, fewer unit cycles, and less part-load operation.

For units used in spaces with high sensible loads, base equipment selection on unit sensible load, not on total anticipated load. Adjust for anticipated room wet bulb temperature to avoid undersizing the equipment.

UNIT MOUNTING (OUTDOOR)

Refer to the unit's installation instructions for further details.

Unit leveling – For reliable operation, units should be level in all planes.

Clearance – Minimum clearance (see Fig. 4) must be provided for airflow. The condensing units are designed for free-flow application. Air inlets and outlets should not be restricted.

Unit location – A location which is convenient to installation and not exposed to strong winds. A location that can bear the weight of the outdoor unit and where the outdoor unit can be mounted in a level position.

Do not install the indoor or outdoor units in a location with special environmental conditions. For those applications, contact your sales representative.

SYSTEM OPERATING CONDITIONS

OPERATING RANGE MIN / MAX °F (°C)		
	COOLING	HEATING
Outdoor DB	-4 / 122 (-20 / 50)	-4 / 86 (-20 / 30)

NOTE: Reference the product installation instructions for more information.

PIPING and REFRIGERANT INFORMATION									
System Size			9K	12K	9K	12K	18K	24K	30K
V-Ph-Hz			115-1-60		208/230-1-60				
Piping	Min. Piping Length	ft(m)	10(3)	10(3)	10(3)	10(3)	10(3)	10(3)	10(3)
	Standard Piping Length	ft(m)	25(7.5)	25(7.5)	25(7.5)	25(7.5)	25(7.5)	25(7.5)	25(7.5)
	Max. outdoor-indoor height difference	ft(m)	32(10)	32(10)	32(10)	32(10)	65(20)	65(20)	82(25)
	Max. Piping Length with no additional refrigerant charge	ft(m)	26(8)	26(8)	26(8)	26(8)	26(8)	26(8)	26(8)
	Max. Piping Length	ft(m)	82(25)	82(25)	82(25)	82(25)	98(30)	98(30)	164(50)
	Additional refrigerant charge (between Standard - Max piping length)	Oz/ft(g/m)	0.16(15)	0.16(15)	0.16(15)	0.16(15)	0.16(15)	0.32(30)	0.32(30)
	Gas Pipe (size - connection type)	in(mm)	3/8(9.52)	1/2(12.7)	3/8(9.52)	1/2(12.7)	1/2(12.7)	5/8(16)	5/8(16)
Liquid Pipe (size - connection type)	in(mm)	1/4(6.35)	1/4(6.35)	1/4(6.35)	1/4(6.35)	1/4(6.35)	3/8(9.52)	3/8(9.52)	
Refrigerant	Refrigerant Type	--	R410A	R410A	R410A	R410A	R410A	R410A	R410A
	Charge Amount	Lbs(kg)	2.76(1.25)	2.76(1.25)	2.76(1.25)	2.76(1.25)	4.19(1.90)	5.18(2.35)	6.62(3.00)

METERING DEVICES

The outdoor unit has an electronic expansion valve to manage the refrigerant flow of the connected fan coil.

DRAIN CONNECTIONS

Install drains to meet the local sanitation codes.

REFRIGERANT LINES

General refrigerant line sizing:

1. The outdoor units are shipped with a full charge of R410A refrigerant. All charges, line sizing, and capacities are based on runs of 25 ft. (7.6 m). For runs over 25 ft. (7.6 m), review the *Long Line Applications* section for the proper charge adjustments.
2. Refrigerant lines should not be buried in the ground. If it is necessary to bury the lines, do not bury more than 36-in (914 mm). Provide a minimum 6-in (152 mm) vertical rise to the service valves to prevent refrigerant migration.
3. Both lines must be insulated. Use a minimum of 1/2-in. (12.7 mm) thick insulation. Closed-cell insulation is recommended in all long-line applications.
4. Special consideration should be given to isolating the interconnecting tubing from the building structure. Isolate the tubing so vibration or noise is not transmitted into the structure.

Long Line Applications:

1. No change in line sizing is required.
2. Add refrigerant per the following table.

ADDITIONAL CHARGE TABLE

UNIT SIZE	TOTAL LINE LENGTH ft		ADDITIONAL CHARGE, oz/ft. ft (m)		
	Min	Max	10 – 25 (3 – 8)	>25 – 82 (8 – 25)	>82 – 164 (25 – 50)
9	10	82	None	0.16	0.32
12		98			
18				164	
24					
30					

WIRING

All wires must be sized per NEC (National Electrical Code) or CEC (Canadian Electrical Code) and local codes. Use the Electrical Data table MCA (minimum circuit amps) and MOCP (maximum over current protection) to correctly size the wires and the disconnect fuse or breakers respectively. Per the caution note, only stranded copper conductors with a 600 volt rating and double insulated copper wire must be used.

The use of BX cable is not recommended.

Recommended Connection Method for Power and Communication Wiring

Power and Communication Wiring:

The main power is supplied to the outdoor unit. The field supplied 14/3 power/communication wiring from the outdoor unit to the indoor unit consists of four (4) wires and provides the power for the indoor unit. Two wires are high voltage AC power, one is communication wiring and the other is a ground wire.

Recommended Connection Method for Power and Communication Wiring (To minimize communication wiring interference)

Power Wiring:

The main power is supplied to the outdoor unit. The field supplied power wiring from the outdoor unit to the indoor unit consists of three (3) wires and provides the power for the indoor unit. Two wires are high voltage AC power and one is a ground wire.

To minimize voltage drop, the factory recommended wire size is 14/2 stranded with a ground.

Communication Wiring:

A separate shielded Stranded copper conductor only, with a 600 volt rating and double insulated copper wire, must be used as the communication wire from the outdoor unit to the indoor unit. Please use a separate shielded 16GA stranded control wire.



CAUTION

EQUIPMENT DAMAGE HAZARD

Failure to follow this caution may result in equipment damage or improper operation.

- Wires should be sized based on NEC and local codes.
- Use copper conductors only with a 600 volt rating and double insulated copper wire.



CAUTION

EQUIPMENT DAMAGE HAZARD

Failure to follow this caution may result in equipment damage or improper operation.

- Be sure to comply with local codes while running wire from the indoor unit to the outdoor unit.
- Every wire must be connected firmly. Loose wiring may cause the terminal to overheat or result in unit malfunction. A fire hazard may also exist. Ensure all wiring is tightly connected.
- No wire should touch the refrigerant tubing, compressor or any moving parts.
- Disconnecting means must be provided and shall be located within sight and readily accessible from the air conditioner.
- Connecting cable with conduit shall be routed through the hole in the conduit panel.

AIR FLOW DATA

System Size		9K	12K	9K	12K	18K	24K	30K
V-Ph-Hz		115-1-60			208/230-1-60			
Outdoor Unit	CFM	1,200	1,200	1,200	1,200	1,390	2,130	2,130

FAN AND MOTOR SPECIFICATIONS

System Size		9K	12K	9K	12K	18K	24K	30K	
V-Ph-Hz		115-1-60			208/230-1-60				
Outdoor Fan Propeller	Material	AS		AS		AS		AS	
	Type	ZL-421*117*8-3K		ZL-421*117*8-3K		ZL-421*117*8-3K		ZL-460*180*10-3N	
	Diameter	16.6		16.6		16.6		18.1	
	Height	4.6		4.6		4.6		7.1	
Outdoor Fan Motor	Model	WZDK40-38G-1	WZDK40-38G-1	WZDK40-38G-W-1	WZDK40-38G-W-1	ZKFN-50-8-2	WZDK120-38G-1	WZDK120-38G-W	
	Phase	3		3		3		3	
	FLA	0.14	0.14	0.42	0.42	0.95	0.47	1.21	
	Type	DC		DC		DC		DC	
	Insulation Class	E		E		E		E	
	Safe Class	IPX0		IPX0		IPX0		IPX0	
	Input Power	42	42	46	46	116	145	150	
	Output Power	40	40	40	40	50	120	120	
	Range of Current	0.14±10%	0.14±10%	0.42±10%	0.42±10%	0.95±10%	0.47±10%	1.21±10%	
	Rated Current	0.14	0.14	0.42	0.42	0.95	0.47	1.21	
	Rated HP	0.053	0.053	0.053	0.053	0.067	0.16	0.16	
	Speed	800/700/600		800/700/600		800/700/600		850/750/700	850/800/750
	Rated RPM	900		900		900		1050	1050
	Max. Input Power	42	42	46	46	116	145	150	

SOUND PRESSURE

System Size		9K	12K	9K	12K	18K	24K	30K
V-Ph-Hz		115-1-60			208/230-1-60			
Outdoor Sound Pressure Level	dB(A)	55.5	56	55.5	56	59	60	63
Outdoor Sound Power Level	dB(A)	65	66	65	66	69	70	73

OUTDOOR UNIT SOUND PRESSURE TEST CONDITIONS

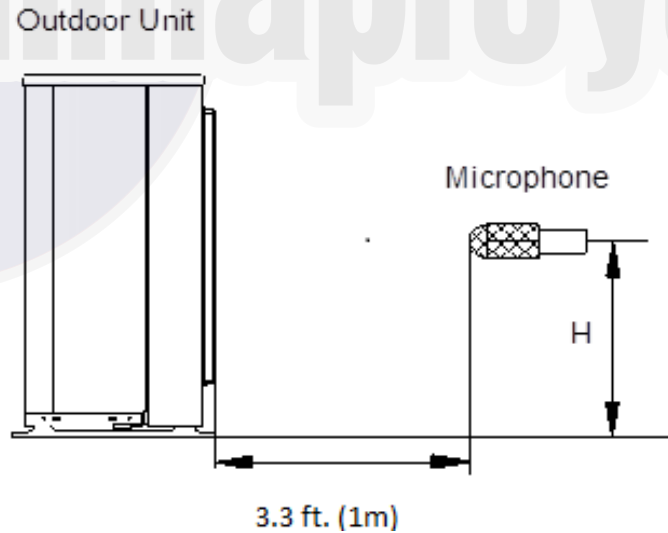

NOTE: H=0.5 x Height of outdoor unit

	INDOOR CONDITION		OUTDOOR CONDITION	
	DB	WB	DB	WB
Cooling	80.6F (27C)	66.2F (19C)	95F (35C)	75.2F (24C)
Heating	68F (20C)	59F (15C)	44.6F (7C)	42.8F (6C)

ELECTRICAL DATA

MAQ OUTDOOR UNIT SIZE		9K	12K	9K	12K	18K	24K	30K
Power Supply	Volts-PH-Hz	115-1-60	115-1-60	208/230-1-60	208/230-1-60	208/230-1-60	208/230-1-60	208/230-1-60
	Max - Min* Oper. Voltage	126-104	126-104	253-187	253-187	253-187	253-187	253-187
	MCA	15	15	15	15	13	15	20
	Max Fuse/ CB AMP	20	20	15	15	20	25	30
Compressor	Volts-PH-Hz	115-1-60	115-1-60	208/230-1-60	208/230-1-60	208/230-1-60	208/230-1-60	208/230-1-60
	RLA	5.3	5.7	5.3	5.7	7.3	8.8	13.5
Outdoor Fan Motor	Volts-PH-Hz	115-1-60	115-1-60	208/230-1-60	208/230-1-60	208/230-1-60	208/230-1-60	208/230-1-60
	FLA	0.14	0.14	0.42	0.42	0.95	0.47	1.21
	Rated HP	0.053	0.053	0.053	0.053	0.067	0.16	0.16
	Output	40	40	40	40	50	120	120

*Permissible limits of the voltage range at which the unit will operate satisfactorily.

LEGEND

- FLA – Full Load Amps
- MCA – Minimum Circuit Amps
- RLA – Rated Load Amps



WIRING DIAGRAMS

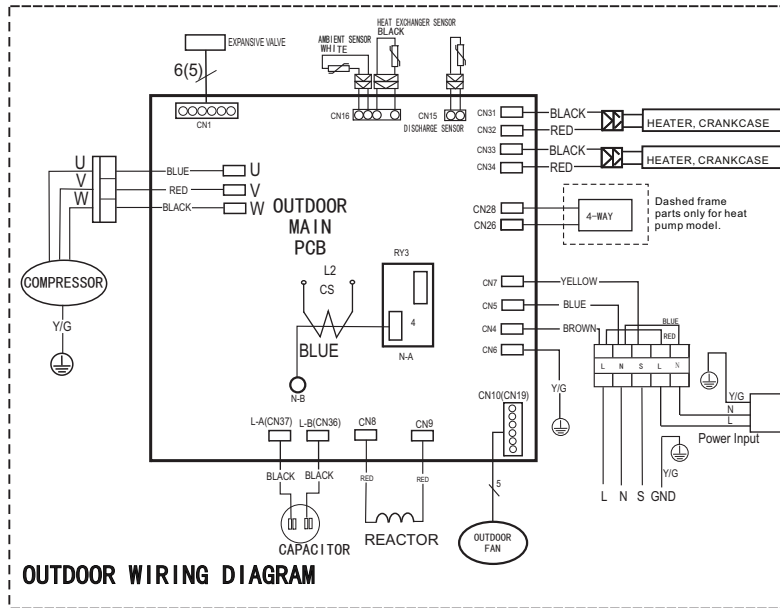

Fig. 5 – Wiring Diagram for 9K & 12K 115V

CODE	PART NAME
CN1	Output: Pin 5&6 (12V) Pin 1–Pin 4: Pulse waveform, (0–12V)
CN15	Input: Pin 1–Pin 2 (0–1.8V)
CN16	Input: Pin1,Pin3 ,Pin4,Pin5 (0–1.8V)
CN19	Output: Pin 1–Pin 5 (0–115V High voltage)
CN31,CN33	Output: 115VAC High voltage
CN32,CN34	Output: 115 VAC High voltage
CN26,CN28	Output: 115 VAC for 4–way control
CN4	Input: 115 VAC High voltage
CN5	Input: 115 VAC High voltage
CN6	Connection to the earth
CN7	Output: Connection of the high voltage
CN8,CN9	Output: High voltage
CN36,CN37	Output: High voltage
N–B	Output: High voltage
U V W	Output: Pulse (0–320VDC)

WIRING DIAGRAMS (CONTINUED)

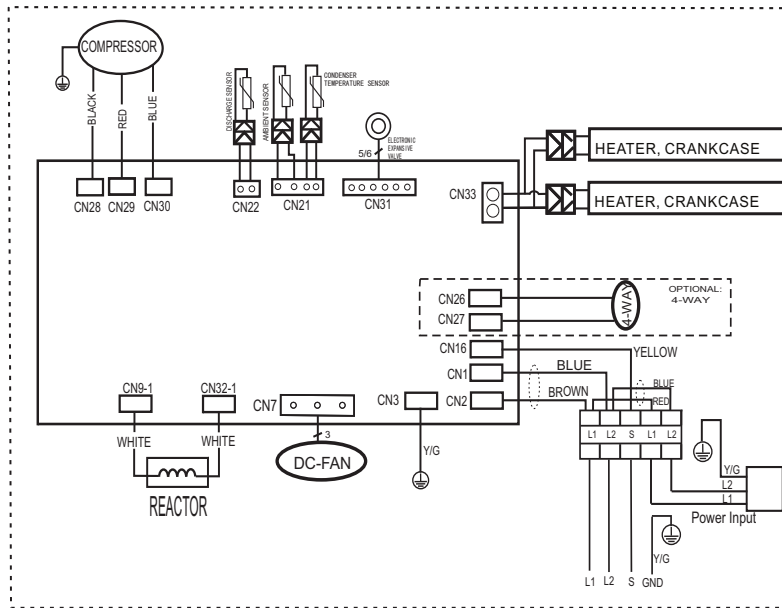

Fig. 6 – Wiring Diagram for 9K & 12K 208/230V

CODE	INPUT or OUTPUT VALUE
CN31	Output: Pin 5&6 (12V) Pin 1–Pin 4:Pulse waveform,(0–12V)
CN21	Input: Pin3–4 (3.3V) Pin 2 (0V),Pin 1,Pin 5 (0–3.3V)
CN22	Input: Pin1 (3.3V) Pin 2 (0–3.3V)
CN37	Output: 230 VAC High voltage
CN9–1,CN32–1	Output: Connection of the high voltage
CN1	Input: 230 VAC High voltage
CN2	Input: 230 VAC High voltage
CN3	Connection to the earth
CN16	Output: Connection of the high voltage
CN26,CN27	Output: High voltage for 4–way control
CN7	Output: Pulse (0–320 VDC) for DC FAN
U V W	Output: Pulse (0–320 VDC) for COMPRESSOR

WIRING DIAGRAMS (CONTINUED)

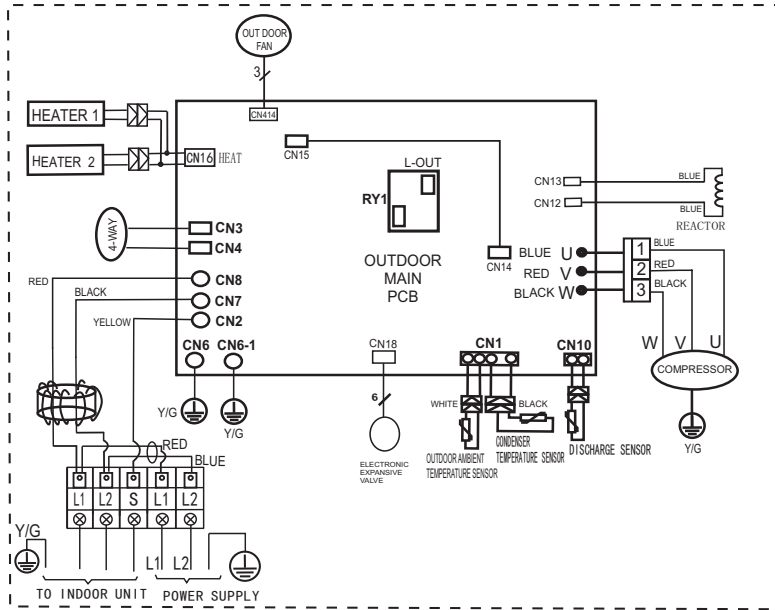

Fig. 7 – Wiring Diagram for 18K 208/230V

CODE	INPUT or OUTPUT VALUE
CN7、CN8	Input: 230V High voltage
CN2	Output: Connection of the high voltage
CN3、CN4	Output: High voltage for 4-way control
CN11、CN16	Output: 230V High voltage for HEATER
CN5	Output: Pulse (0–320V) for DC FAN
CN12、CN13	Output: Connection of the high voltage
U V W	Output: Pulse (0–320V) for compressor
CN10	Input: Pin 1 (5V) Pin 2 (0–5V)
CN1	Input: Pin 3–4 (5V) Pin 2 (0V), Pin 1, Pin 5 (0–5V)
CN18	Output: Pin 5&6 (12V) Pin 1–Pin 4: Pulse waveform, (0–12V)

WIRING DIAGRAMS (CONTINUED)

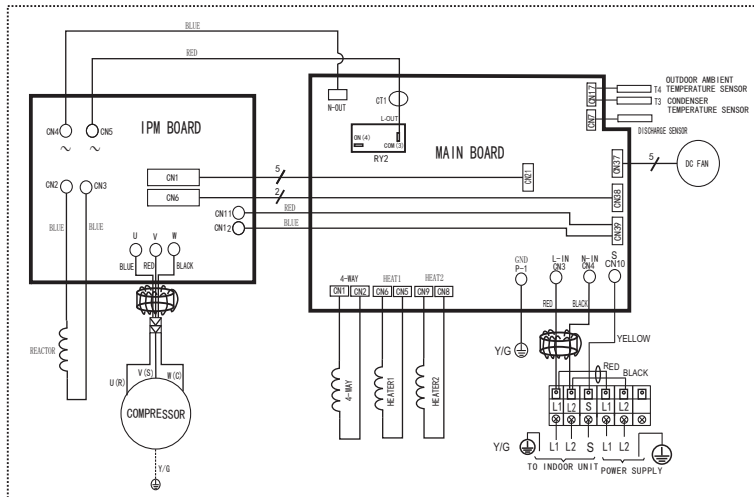

Fig. 8 – Wiring Diagram for 24K 208/230V

CODE	INPUT or OUTPUT VALUE
L_IN	Power Voltage: AC 230V
CN11	Power Voltage: AC 230V
CN16	Relative to the N terminal voltage: DC24V
CN15	Maximum voltage: DC 5V
CN6	Maximum output voltage: AC230V
CN4	Indoor fan interface, Maximum voltage: DC310V
CN5	Stepper motor interface, Maximum voltage between the lines: DC12V
P_1	Ground
CN8	Room temperature sensor interface, maximum voltage: DC 5V
CN9	Pipe temperature sensor interface, maximum voltage: DC 5V
CN10A	Display interface, maximum voltage between the lines DC5V
CN14	Stepper motor interface (optional), maximum voltage between the lines: DC12V

WIRING DIAGRAMS (CONTINUED)

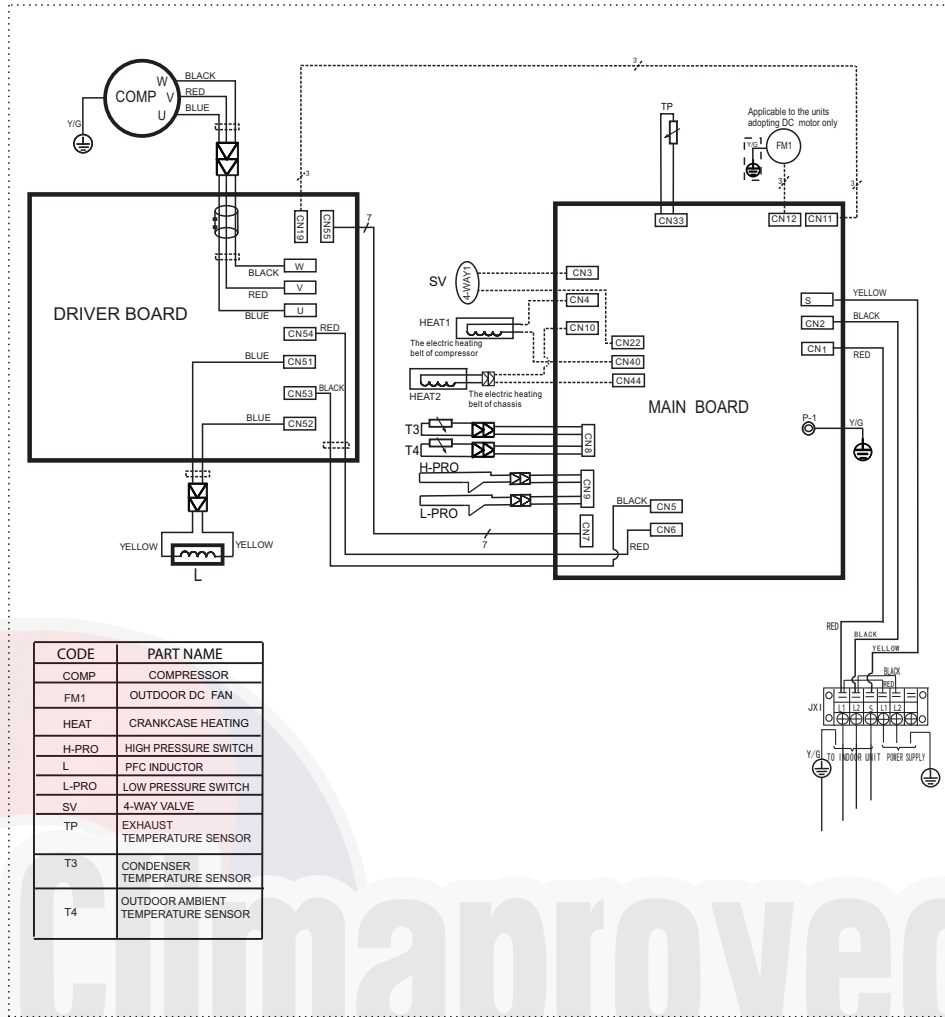

Fig. 9 – Wiring Diagram for 30K 208/230V

CODE	INPUT or OUTPUT VALUE
CN1, CN2	Input: 230V High voltage
S	Output: Connection of the high voltage
CN11, CN12	Output: Pulse (0–320V) for DC FAN
CN33	Input: Pin 1 (5V) Pin 2 (0–5V)
CN3, CN22	Output: High voltage for 4–way control
CN4, CN40	Output: 230V High voltage for HEATER 1
CN10, CN44	Output: 230V High voltage for HEATER 2
CN8	Input: Pin 3–4 (5V) Pin 2 (0V), Pin 1, Pin 5 (0–5V)
CN9	Input: Pin 1–3 (0V) Pin 2–4 (0–5V)
CN51 CN52	Output: Connection of the high voltage
U V W	Output: Pulse (0–380V) for compressor

GUIDE SPECIFICATIONS

HORIZONTAL DISCHARGE OUTDOOR UNITS

Size Range: 3/4 to 2 1/2 Ton Nominal Cooling and Heating Capacity
Carrier Model Number: 38MAQ

PART 1 – GENERAL

1.01 System Description

- A. Outdoor air-cooled system compressor sections suitable for on-the-ground, rooftop, wall hung or balcony mounting. Units consist of a rotary compressor, an air-cooled coil, propeller-type draw-through outdoor fan, reversing valve (HP), accumulator (HP units), metering device(s), and a control box. Units discharge air horizontally as shown on the contract drawings. Units function as the outdoor component of an air-to-air heat pump system.
- B. Units are to be used in a refrigeration circuit matched to ductless heat pump fan coil units.

1.02 Agency Listings

- A. Unit construction complies with ANSI/ASHRAE 15, latest revision, and with the NEC.
- B. Units are evaluated in accordance with UL standard 1995.
- C. Units are listed in the CEC directory.
- D. Unit cabinet is capable of withstanding a 500-hour salt spray test per Federal Test Standard No. 141 (method 6061).
- E. Air-cooled condenser coils are leak tested at 550 psig.

1.03 Delivery, Storage, And Handling

Units are shipped in one piece and are stored and handled per the unit manufacturer's recommendations.

1.04 Warranty (For Inclusion By Specifying Engineer)

PART 2 – PRODUCTS

2.01 Equipment

A. General:

Factory assembled, single piece, air-cooled outdoor unit. Contained within the unit enclosure is all the factory wiring, piping, controls, and the compressor.

B. Unit Cabinet:

1. Unit cabinet is constructed of galvanized steel, bonderized and coated with a baked-enamel finish on the inside and outside.
2. Unit access panels are removable with minimal screws and provides full access to the compressor, fan, and control components.
3. The outdoor compartment is isolated and has an acoustic lining to assure quiet operation.

C. Fans:

1. Outdoor fans are the direct drive propeller type, and discharge air horizontally. Fans draw air through the outdoor coil.
2. Outdoor fan motors are totally enclosed, single phase motors with class E insulation and permanently lubricated ball bearings. Motor is protected by internal thermal overload protection.
3. The shaft has inherent corrosion resistance.
4. Fan blades are non-metallic and statically and dynamically balanced.
5. Outdoor fan openings are equipped with a PVC metal/mesh coated protection grille over the fan.

D. Compressor:

1. Compressor is the fully hermetic rotary type.
2. Compressor is equipped with an oil system, operating oil charge, and a motor.
3. Motor is NEMA rated class E, suitable for operation in a refrigerant atmosphere.
4. Compressor assembly is installed on rubber vibration isolators.

E. Outdoor Coil:

The coil is constructed of aluminum blue hydrophilic pre-coated fins mechanically bonded to seamless copper tubes, which are cleaned, dehydrated, and sealed.

F. Refrigeration Components:

Refrigerant circuit components include a brass external liquid line service valve with service gage port connections, a suction line service valve with a service gage connection port, service gage port connections on a compressor suction and discharge lines with Schrader type fittings with brass caps, accumulator, reversing valve.

G. Controls and Safeties:

Operating controls and safeties are factory selected, assembled, and tested. The minimum control functions include the following:

1. Controls:
 - a. A time delay control sequence is provided standard through the fan coil board
 - b. Automatic outdoor fan motor protection.
2. Safeties:
 - a. System diagnostics
 - b. Compressor motor current and temperature overload protection
 - c. Outdoor fan failure protection.

H. Electrical Requirements:

1. Unit operates on single-phase, 60 Hz power at 115V for unit sizes 09-12 and 208/230V for unit sizes 09, 12, 18, 24 and 30 as specified.
2. Unit electrical power has a single point connection.
3. Unit Control voltage to the indoor fan coil is 0-15V DC.
4. All power and control wiring must be installed per NEC and all local electrical codes.
5. The unit has both high and low voltage terminal block connections.