

INSTALLATION INSTRUCTIONS

OUTDOOR SPLIT SYSTEM COOLING (3 to 7.5 TONS)

Supersedes: Nothing

550.46-N1U (999)

035-15272-001

3 PHASE 10 SEER

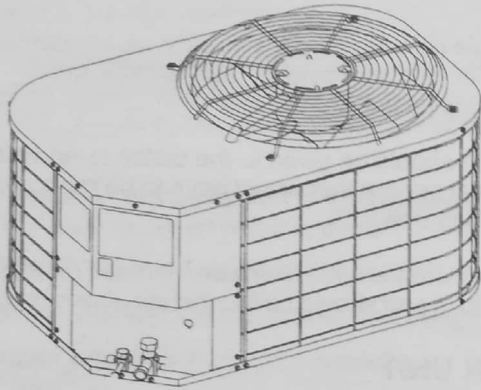

GENERAL

These outdoor units are designed to be connected to a matching UPG indoor coil with sweat connection lines. These units are factory charged with refrigerant for a matching indoor coil plus 15 feet of field supplied line. The outside unit is designed to be placed alongside or at the back of the home, remote from the indoor coil. The outdoor unit has been factory run-tested and all components of the system are ready for easy, immediate installation.

INSPECTION

Check the unit thoroughly for shipping damage. Unusually rough handling during shipment may loosen fan motors, compressors, or other components. Be sure that the unit is ready to operate before installing it. If there is damage, file a claim with the shipper.

REFERENCE

Use this instruction in conjunction with the instructions for the appropriate indoor unit, air moving system and accessories.

Installer should pay particular attention to the words NOTE, CAUTION and WARNING.

NOTES are intended to clarify or make the installation easier.

CAUTIONS identify procedures which, if not followed carefully, could result in personal injury, property damage or equipment damage.

WARNINGS are given to alert the installer that severe personal injury, death or equipment damage may result if installation procedures are not followed properly.

LIMITATIONS

CAUTION

The manufacturer is not responsible for the performance of a mismatched system. The outdoor unit must be installed with a compatible indoor unit as designated in the specification data or in the Directory of Certified Unitary Air Conditioners published by the Air Conditioning and Refrigeration Institute. Using unmatched components may not only affect the performance of the system, but may also void the warranty of the equipment.

Do not install any coil in a furnace which is to be operated during the heating season without attaching the refrigerant lines to the coil. Allowing the coil charge to enter the refrigerant lines prevents excessive refrigerant pressure build-up and possible coil damage.

The unit should be installed in accordance with all national and local codes and regulations which govern the installation of this type of equipment. In lieu of local codes, the equipment should be installed in accordance with National Electric Code, and in accordance with the recommendations made by the National Board of Fire Underwriters.

Limitations for the indoor unit, coil and appropriate accessories must also be observed.

The outdoor unit must not be installed with any duct work in the air stream. The outdoor fan is the propeller type and is not designed to operate against any additional external static pressure.

The maximum and minimum conditions for operation must be observed to assure a system that will give maximum performance with minimum service.

Table 1 - Application Limitations

Ambient Air Temperature on Outdoor Coil		Air Temperature on Indoor Coil	
Min. DB	Max. DB	Min. WB	Max. WB
50	120	57	72

CHECK ELECTRICAL POWER SUPPLY

The electrical power should be checked to determine if adequate power is available, and near constant voltage can be maintained. If there is any question concerning the power supply, contact the local power company for corrections; otherwise, unsatisfactory performance may result.

SELECTING EQUIPMENT LOCATIONS

Several important factors must be considered before selecting the best site for the air conditioning outside unit:

- D Distance to indoor coil
- D Proximity to the structure
- D Proximity to vents and exhaust systems
- D Ability to service
- D Sound transmission
- D Air circulation
- D Wind direction
- D Relationship between structure, sun, and unit
- D Distance from power source
- D Water drainage
- D Local codes

Locate the outside unit near enough to the indoor coil vicinity to eliminate lengthy refrigerant line runs. Do not locate the outside unit so it discharges air under eaves or gutters. Rain or snow melt-off should not be able to run off a roof and down upon the unit. Be sure vents are not located upwind from the outside unit.

A minimum clearance of 18 inches is required for service at the control panel and compressor compartments access. A 10 inch clearance is required for the air inlet to the outdoor coil around the perimeter of the unit. The air discharge of the unit requires a 60 inch clearance between the top of the unit and any obstruction. See Figure 1.

The length of the refrigerant tubing, between the outdoor unit and indoor coil, should be as short as possible to avoid capacity and efficiency loss. Excessive spacing of the outside unit from the home can lead to the refrigerant lines being restricted by trampling or by being punctured by lawn mowers. Locate unit away from bedroom windows or other rooms where sound might be objectionable.

Adverse effects of prevailing winds, blowing snow or sleet on the outdoor coil can be eliminated by placing the outside unit where the wind does not blow across the unit. Trees, shrubs, corners of buildings and fences standing off from the coil can reduce capacity loss due to wind chill effect.

Provide ample clearance from shrubs to allow adequate air to pass across the outdoor coil without leaves or branches being pulled into the coil.

Consideration should be given to the distance and routing of electrical service that would have to be run to connect the outside unit.

It is recommended the outside unit be mounted on a concrete pad. Top of pad should be two inches above grade.

OUTDOOR UNIT

After the site has been selected a concrete base pad should be provided. The concrete pad should not come in contact with the foundation or side of the structure because sound may be transmitted to the residence. The concrete pad need not be any larger than the outside dimensions of the outdoor unit. The concrete pad should be located far enough away from the structure so the outside unit is not closer than its minimum distances. See Figure 1. Set the outside unit upon the pad with care to avoid damage.

CAUTION

Do not remove the protective caps or plugs from the unit refrigerant connections until the refrigerant lines are run and ready for final connection. If this procedure is not observed, dirt and other particles will get into the system and plug various orifices and small tubes.

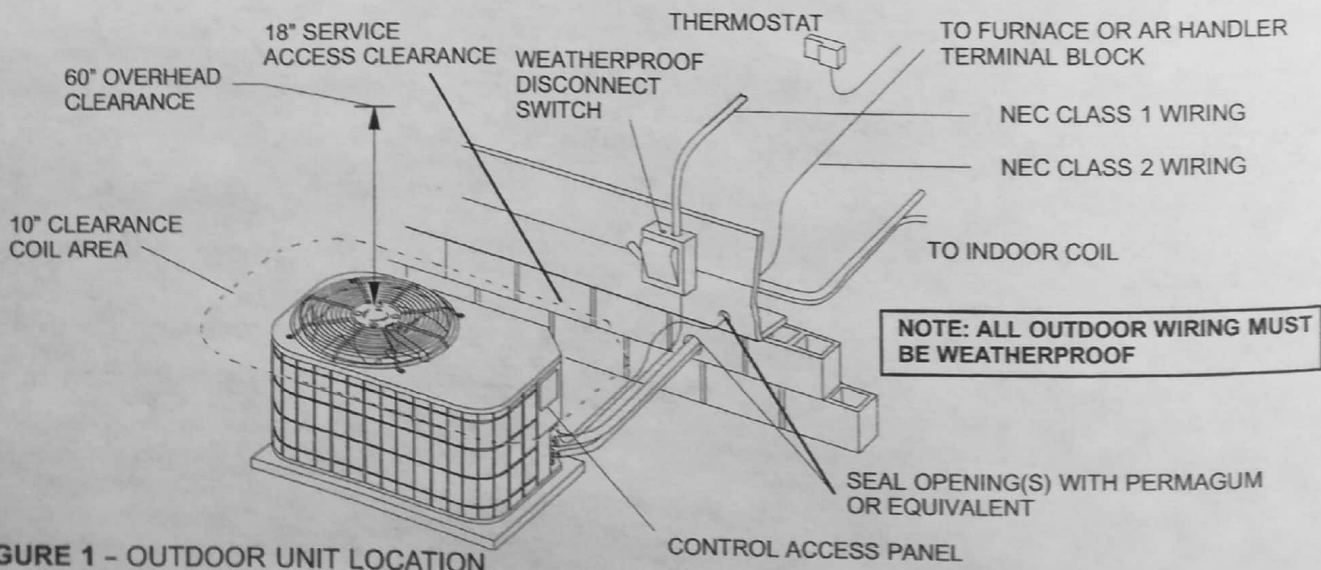

FIGURE 1 - OUTDOOR UNIT LOCATION

INDOOR UNITS

Install the indoor coil in the furnace or air handler according to the installation instructions packed with each component.

REFRIGERANT LINES

The following steps are very important when setting up a refrigerant system and need to be followed completely to ensure that a strong, flexible and leak tight system is obtained.

The installation of the copper refrigerant tubing must be done with care to obtain reliable, trouble-free operation.

1. Selecting of proper refrigerant tubing grade and size.
2. Refrigerant line routing, cutting and fitting.
3. Proper preparation of joint connections.
4. Reassembling, cleaning and brazing the joint connections.
5. Insulating the vapor line.
6. Connecting the refrigerant lines to the indoor coil and outdoor unit.
7. Pressure leak test all joints.
8. Evacuate refrigerant lines and indoor coil.
9. Charging refrigeration system (if the line length is other than 15 feet.) See Table 2.

Table 2 - Refrigerant Line Charges

Liquid OD	Vapor OD	R-22 Charge, OZ/FT
3/8"	5/8"	0.66
3/8"	3/4"	0.68
3/8"	7/8"	0.70
3/8"	1-1/8"	0.76
1/2"	1-1/8"	1.26

Use only ACR grade copper tubing and keep ends sealed until joints are made.

The correct diameters of the refrigerant lines are listed on the unit nameplate.

For best performance, select routing of refrigerant lines for minimum distance and fewest number of bends.

Determine the path that the refrigerant lines will follow.

Starting at either the indoor coil or the outdoor unit refrigerant line connections, carefully measure, cut, de-burr, and fit copper refrigerant lines along the path previously determined.

NOTE: If it is necessary for bends to be formed in the vapor line, the radius should not be less than 12 inches.

Cut ends of the copper tubing square.

Remove all burrs from tubing with a reamer, file or deburring tool.

Slope tubing towards the outdoor unit.

When the indoor coil is above the outdoor unit the vapor line should be sloped toward the outdoor unit with a fall of least 1/4 inch per 5 FT.

When the outdoor unit is above the indoor coil the horizontal runs should be sloped toward the outdoor unit as described above.

RE-ASSEMBLING, BRAZING AND CLEANING OF JOINT CONNECTIONS

CAUTION

When using hard solder, an inert gas such as dry nitrogen must be introduced and permitted to flow through tubing during brazing to displace air and prevent oxidation.

Remove the Schrader valve cores from the service valves. Remove the plugs from the service valve field tubing connections. Clean the joints to be brazed.

NOTE: Do not overheat the connection to be brazed as this can cause improper flow of solder, resulting in a weak and leaking joint. Never apply heat directly to face of fitting. Do not heat solder by direct contact with flame of the torch.

When brazing copper tubing it is very important to pre-heat the entire joint before applying the solder. This is done by sweeping the flame steadily and evenly around the fitting, to bring both fitting and tubing up to equal temperature before applying the solder.

Reassemble groups of tubing and fittings, brazing several joints instead of one joint at a time. This reduces the chance for error in the alignment of the assembly. Replace schrader valve cores. **DO NOT OPEN SERVICE VALVES AT THIS TIME.**

INSULATION OF VAPOR LINE

Insulate vapor line with 3/8" (or that required by local code) closed cell insulation.

Slide tubing insulation onto the vapor line so that it is covered completely from the indoor coil to the outdoor unit. Be sure that the tubing is capped before sliding on insulation.

It is not necessary to insulate the liquid line.

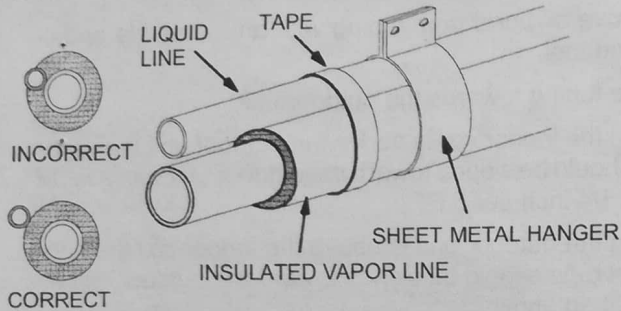

FIGURE 2 - INSULATION OF VAPOR LINE

NOTE: In areas of extreme temperatures and humidity, additional insulation may be required to prevent excessive condensation and loss of capacity.

Do not insulate liquid line and vapor line together. Liquid line should not be in contact with the vapor line. See Figure 2.

REFRIGERANT LINE SUPPORT

Refrigerant lines should be supported in a way that no dips or sags occur. We recommend four feet between supports. If refrigerant lines are to be attached to the home structure, care should be taken to eliminate the transmission of vibrations. Attach the refrigerant lines to the indoor coil first. Remove plugs from the indoor coil, then clean joints to be brazed. Braze refrigerant lines to the indoor coil. Attach refrigerant lines to the outdoor unit.

CHARGING AND LEAK TESTING

On systems with or without service valves the refrigerant should be recovered or recycled in accordance with EPA regulations. In some cases this may require putting piercing valves on both the high and low sides of the system.

WARNING

DO NOT vent refrigerant to the outdoors.

When recovering refrigerant from a system, with a burn-out, follow a safe procedure due to possible contamination.

CAUTION

Avoid getting the refrigerant in the eyes or on the skin.

Contaminated refrigerant must be recovered and returned to the local refrigeration supply house for proper disposition.

TOTAL LINE LENGTH

Units should be installed only with approved system combination (indoor/outdoor) as specified in the Technical Guide.

For systems with total line length exceeding 50 feet, see APPLICATION DATA, 690.01-AD1V(1296) and worksheet 690.01-AD1.1V(791) "General Piping Recommendations and Refrigerant Line Length" for vapor and liquid line sizing, calibration of liquid line pressure loss or gain, determination of vapor line velocity, elevation limitations, orifice connections, system charging, traps, etc.

System with liquid line pressure loss or gain greater than 11 psi must be provided with corrected orifice size as noted in Form 690.01 - AD1V (1296).

ORIFICE SELECTION

NOTE: The proper orifice must be installed in the indoor coil liquid line connection prior to the connection of the refrigerant lines.

WARNING

The indoor coil is under 35 psig (inert gas) pressure.

Each coil has an orifice installed in the fitting between the liquid line connection and distributor. The orifice is identified on a label next to the liquid line connection.

The orifice shipped with the outdoor unit is based on the "most sold" combination, but it may be changed, depending on the capacity and efficiency of the outdoor unit, elevation differences, and/or long total line lengths. An additional orifice(s) is shipped with most outdoor units for the most commonly required replacement combinations. Other sizes must be ordered from Source 1 Parts if required.

See the appropriate Tabular Data Sheet for the correct orifice size and charge adder. If the orifice size matches, nothing further is required and the refrigerant lines may be connected per the outdoor unit instruction. However, if another orifice should be used, see the coil instruction for details to change the orifice in the coil.

OPENING BASE VALVES

All models in this series have brass service valves. These valves are not back seating. Opening or closing valve does not close service port. Service ports have Schrader valves for gauge connections. Use back-up wrench on valve body when removing cap to open or close the valve. To open, insert hex wrench into stem and back out counter clockwise until stem just touches retaining ring.

CAUTION

If the valve stem is backed out beyond the retaining ring, system pressure could force the stem out of the valve body and possibly cause personal injury. In the event that the retaining ring is missing do not attempt to open the valve.

All caps must be replaced to prevent leaks.

Some units may have factory installed 1-1/8" ball valves. To open the valve, remove the brass valve stem cap, located on the side of the valve, with an adjustable wrench. Next, turn the valve stem 1/4 turn CCW (away from unit).

Replace valve cap finger tight, then tighten an additional 1/6 of a turn with a wrench, using a back-up wrench on the valve body.

OIL TRAPPING

When the outdoor unit is above the indoor coil oil trapping is necessary. Please refer to APPLICATION DATA, 690.01-AD1V (1296) and worksheet 690.01-AD1.1V (791) "General Piping Recommendations and Refrigerant Line length".

Check the system for correct charge after all components of the system have been installed, connected and wired correctly.

Connect service gauges to low pressure port and discharge service ports.

Allow unit to operate until system pressures and temperatures have stabilized, making sure that the pressure and temperature align with unit service data. If not, check system charge and adjust if necessary.

ELECTRICAL WIRING

WARNING

To prevent electrical shock, open remote disconnect so electrical supply to outdoor unit is shut off. Contactor does not open both sides of the 208/230 or 460 volt electrical circuit.

POWER SUPPLY

All wiring must comply with N.E.C. and local codes. See rating plate and product data sheet for volts, frequency, phase, maximum fuse size and minimum branch circuit ampacity. Refer to the wiring diagram inside the unit control box cover before connecting to power supply.

1. The line voltage service wiring for the outdoor unit must include a disconnect switch located within sight of the outdoor unit.
2. Use the correct size fuse or circuit breaker as listed on the unit rating plate and data sheet. See Tabular Data Sheet for minimum recommended wire size. If using nonmetallic-sheathed cable (NM or NM-B) ampacities shall be that of 60° C conductors per NEC 336-26.
3. Wiring connections. — Two are provided in the control box:
 - a. One for low voltage wiring.
 - b. One entrance for high voltage.

The reversible High Voltage Conduit Plate is factory installed for 1/2" conduit connections. For 3/4" conduit, remove the screw holding the plate in place and reverse the location of the holes. For 1" conduit, remove the conduit plate and discard. Re-install screw to maintain the integrity of the unit structure, regardless of the conduit being used. See Figure 3.

4. Power connection to the unit is facilitated by screw terminals on the outdoor unit contactor. See Figure 3.
5. Ground the outdoor unit using the ground lug provided. Unless the outdoor unit is grounded through proper wiring to the service entrance ground, a suitable separate ground should be provided at the outdoor unit.

CAUTION

Casing or cabinet must be permanently grounded in accordance with National Electric Code or other applicable local codes.



FIGURE 3 - OUTDOOR UNIT CONTROL BOX (036, 048 & 060 MODELS)

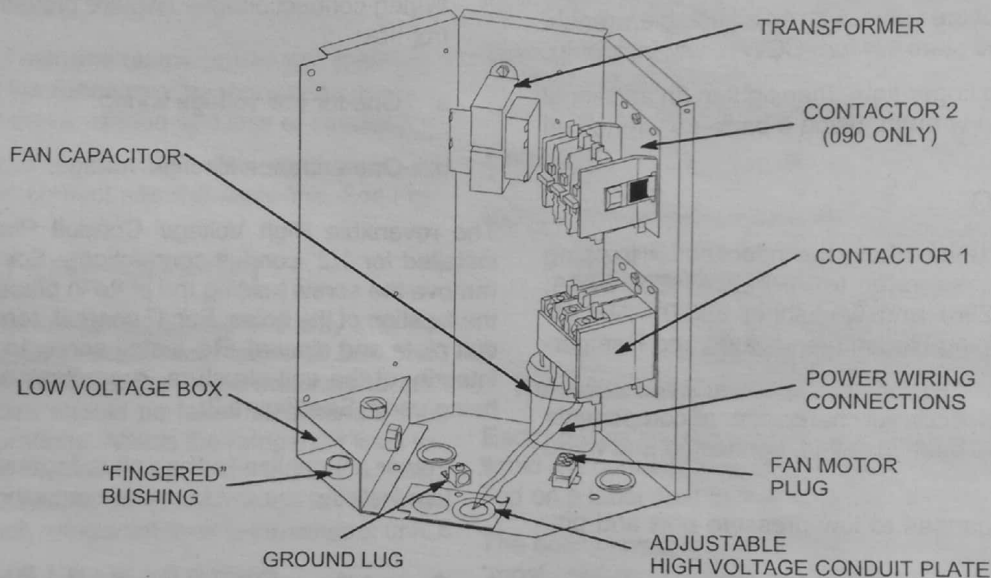

FIGURE 4 - OUTDOOR UNIT CONTROL BOX (076 & 090 MODELS)

LOW VOLTAGE

Control wiring may vary, depending upon the type of thermostat, furnace or air handler being connected.

Low voltage wiring diagrams can be found with the furnace or air conditioning blower package installation instructions.

Pig-tail connector wires are provided from the low voltage pull-in coil on the contractor to a section of the control box. A "fingered" bushing is provided in the low voltage knockout hole. If 1/2" conduit is used for the low voltage wiring, the bushing is to be removed.

1. Route the low voltage cable through the fingered bushing in the low voltage junction box. See Figure 3 or 4.
2. Using wire nuts, connect the low voltage wiring as shown in Figure 5, 6 & 7.
3. A minimum of 18 AWG wire gauge for total lengths not exceeding 130 feet must be used in connecting the low voltage control wiring between the outdoor unit, furnace and thermostat. For longer low voltage control wiring lengths, consult the N.E.C.

Connect thermostat and control package wiring as shown in Figure 5-7 and per the instructions packed with those pieces.

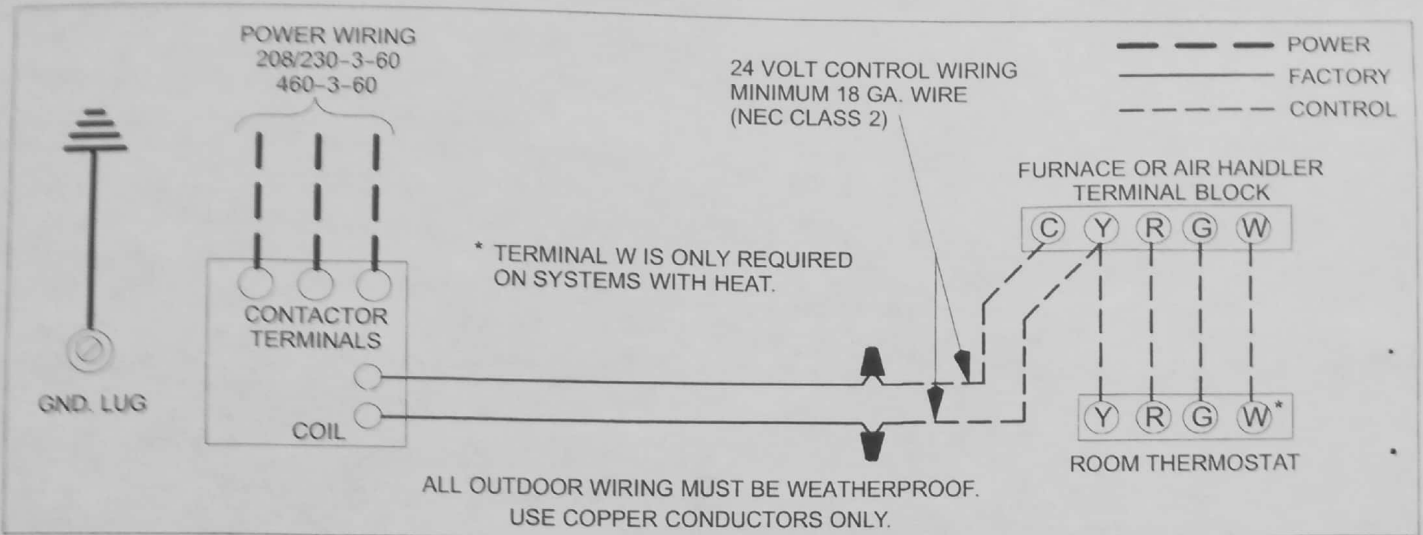

FIGURE 5 - TYPICAL FIELD WIRING FOR 036 - 060 MODELS

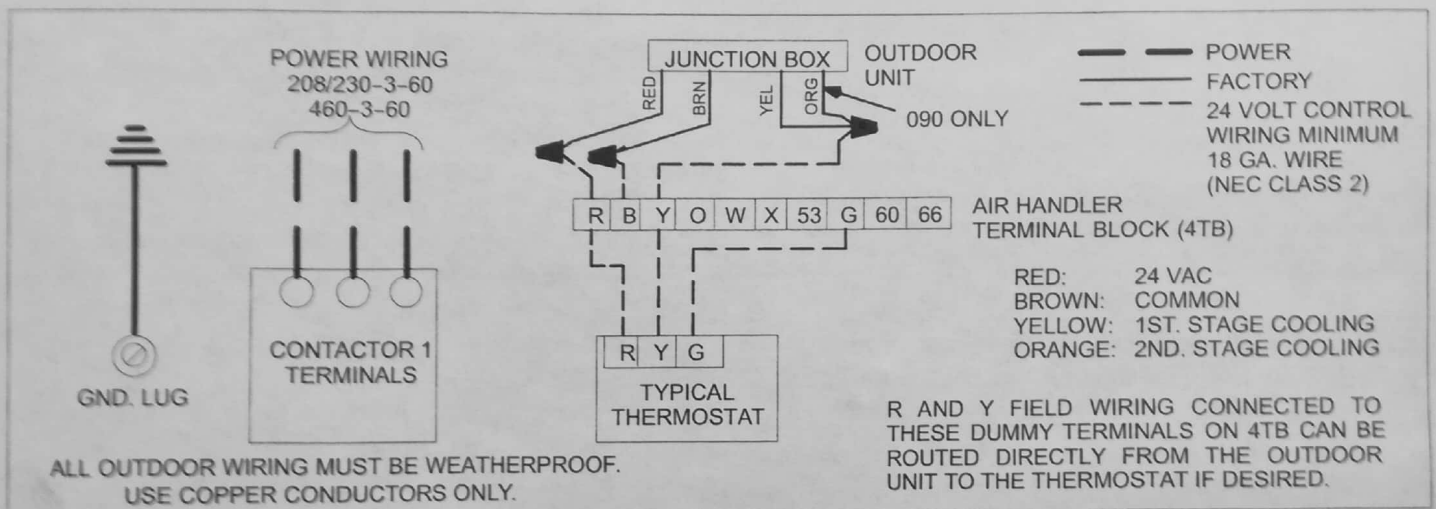

FIGURE 6 - TYPICAL FIELD WIRING FOR 076 & 090 MODELS WITH AIR HANDLER

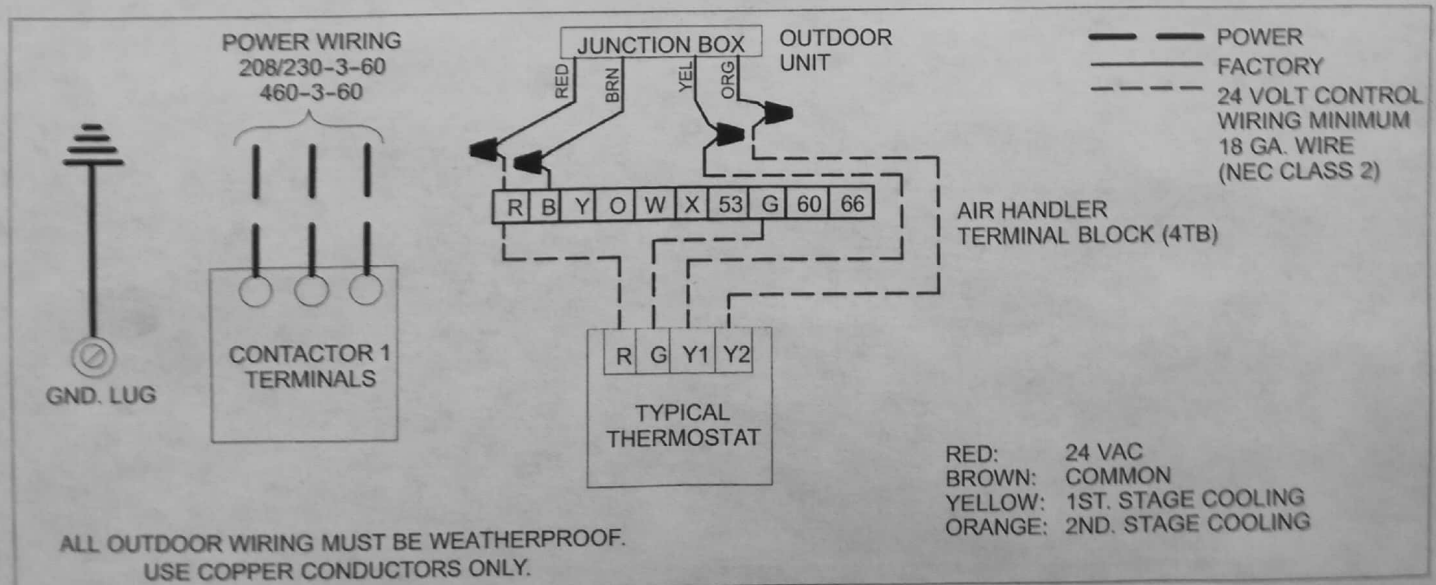

FIGURE 7 - TYPICAL FIELD WIRING FOR TWO STAGE 090 MODEL WITH AIR HANDLER

SYSTEM CHARGE

The factory charge in the outdoor unit includes enough charge for the unit and a most sold matched evaporator. Some indoor coil matches may require some additional charge.

Sweat connect units also include sufficient charge for 15 feet of lines. Pre-charged line lengths are factory charged with the correct amount of refrigerant required. Table 2 lists the refrigerant line charges.

The "TOTAL SYSTEM CHARGE" must be permanently stamped on the unit data plate.

Total system charge is determined as follows:

1. Determine outdoor unit charge from tabular data sheet.
2. Determine indoor coil adjustment from tabular data sheet.
3. Calculate the line charge using Table 2 factors. Calculate over 15 feet of sweat lines for sweat connect units.

NOTE: For sweat connect lines, the line charge over 15 feet should be included on the data plate and must be added to the system.

4. Total system charge = 1 + item 2 + item 3.
5. Permanently stamp the unit plate with the total amount of refrigerant in the system.

CHECKOUT PROCEDURE

Use the following list to see that nothing was over looked.

- Have all braze joints on refrigerant lines been leaked checked?
- Have base valves been opened?
- Have all refrigerant lines been secured and isolated properly?
- Is the indoor coil drain hooked up and draining freely? Pour water in drain pan.
- Is air filter installed and clean?
- Is blower motor speed set correctly?

SYSTEM OPERATION CHECK-OUT

Step 1 - With thermostat set to the OFF position, close disconnect switch or switches to complete circuits to condensing unit, furnace or air handler. Set thermostat to call for cooling.

Step 2 - After the system starts, check the voltage and amperage at the condensing unit contactor.

Step 3 - If voltage is not within 10% of rated voltage, or amperage greatly exceeds nameplate amperage, shut down the system and contact the local power company for corrections; otherwise unsatisfactory performance may result.

Step 4 - With the system in operation, check the condensing unit for unusual noises and undue vibration.

Step 5 - Allow the system to operate until it is balanced or stabilized (approximately 30 minutes), before making further check.

Remove manifold gage hoses and install cap on Schrader valves.

INSTALLER

After installation is complete, place unit data sheet and installation instructions in customer packet and give to home owner.

Subject to change without notice. Printed in U.S.A.
Copyright © by Unitary Products Group 1999. All rights reserved.

035-15272-001 (999)
550.46-N1U

Unitary	5005	Norman
Products	York	OK
Group	Drive	73069