



Carrier Technology  
turn to the experts 

# WIRED REMOTE CONTROLLER

---

## INSTALLATION MANUAL

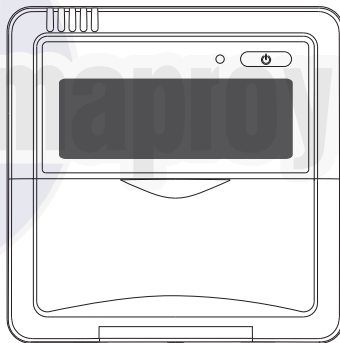

ClimateDirectors.com

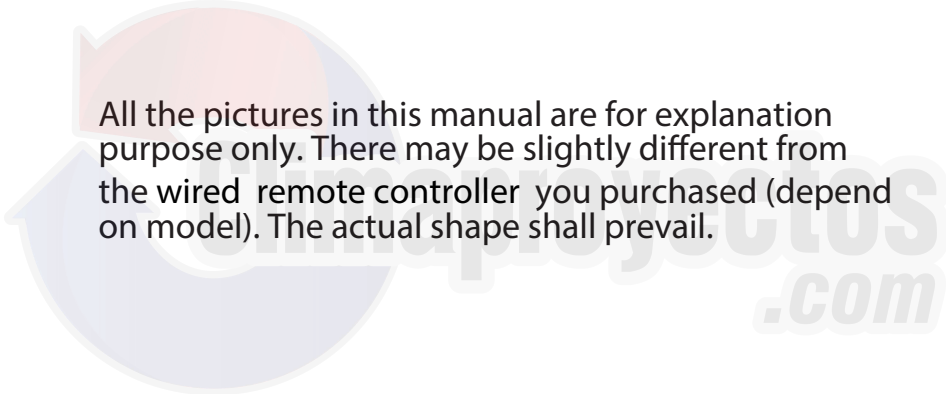

All the pictures in this manual are for explanation purpose only. There may be slightly different from the wired remote controller you purchased (depend on model). The actual shape shall prevail.

# Table of Contents

Wall-Mounted Remote Control Wiring.....	1
Wall-Mounted Remote Control Installation .....	6
Constant Air Volume Testing.....	13

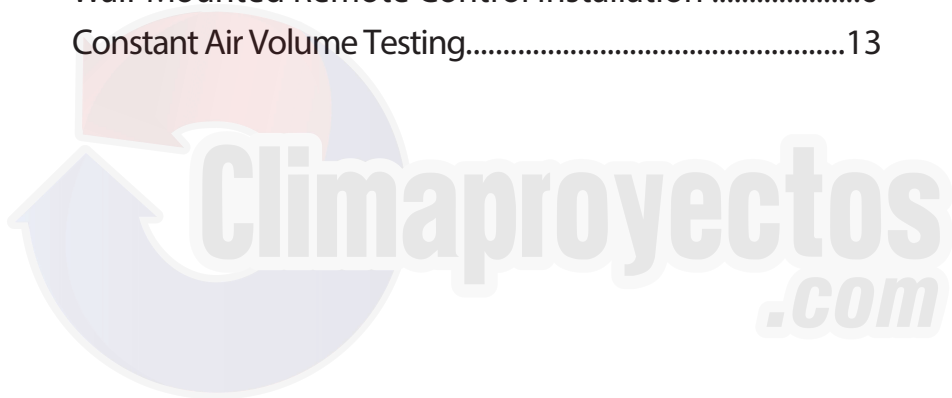

## Wall-Mounted Remote Control Wiring



### WARNING

- The wiring should adapt to the wire control current. Otherwise, electric leakage or overheating may occur and result in fire.
- The specified cables shall be used in the wiring. No external force may be applied to the terminal. Otherwise, the wire may be damaged and heating may occur and result in fire.



### CAUTION

- The shielded wire must be grounded.
- The connecting cable should not be longer than 20m (65.5').
- The remote control operates on a low voltage circuit loops. **DO NOT** connect a 220V or 380V cable to the circuit loop.
- Make sure that configured tubes are 30-50cm (12-20") or more apart.
- **DO NOT** employ an ohmmeter to detect the insulation after wiring the remote control.

# An overview of the wall-mounted remote control wire outlet

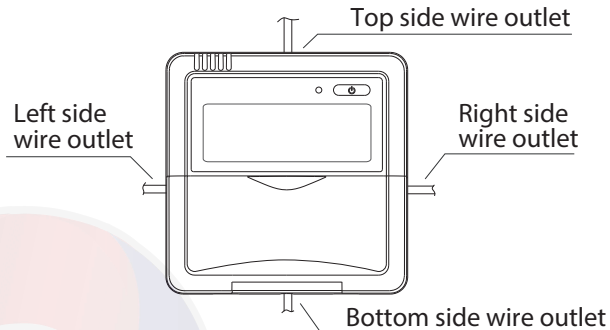

Fig. 1

## 1. Wiring diagram

Refer to the following diagram to wire the wall-mounted remote control to the indoor unit.

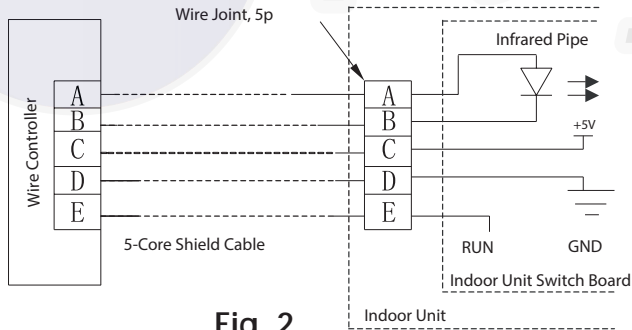

Fig. 2

## 2. Installation Diagram

Connect the wire from the display panel of the indoor unit to a connecting cable. Then connect the other side of the connecting cable to the remote control.

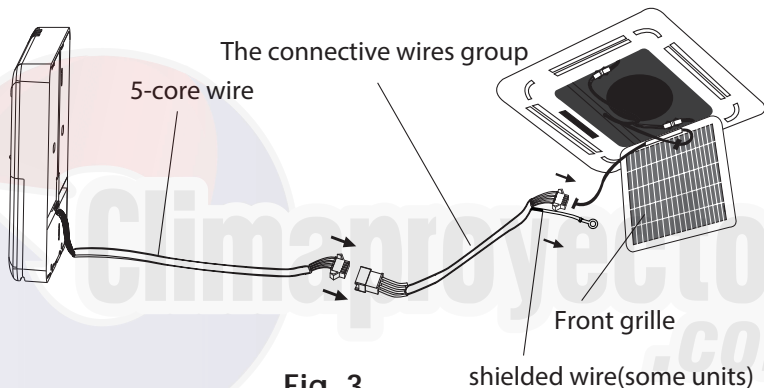
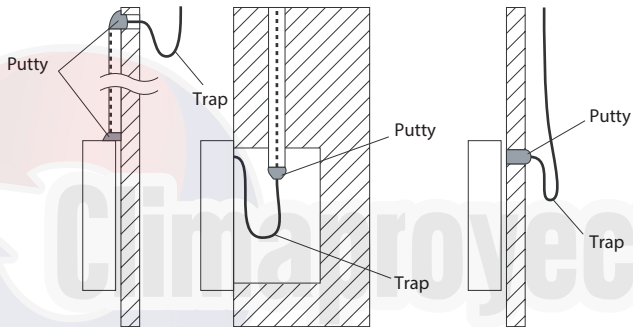

Fig. 3

**NOTE:** Be sure to reserve a length of the connecting wire for periodic maintenance. If there is a connection lug at the end of shielded wire, the connection lug should be properly grounded.

**NOTE: DO NOT** allow water to enter the remote control.  
Use the trap and putty to seal the wires.



**Fig. 4**

- For exposed mounting, cut holes on four of the sides according to Fig. 5.
- For shielded wiring, please refer to Fig. 6.

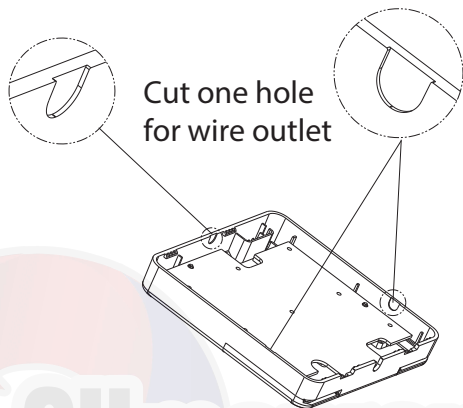
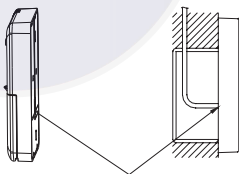

Fig. 5

Embedded switch box wiring

Wiring through the wall



Wiring hole

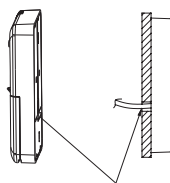

Wall hole and wiring hole  
Diameter of wall hole:  $\Phi$  2cm

Fig. 6



## Wall-Mounted Remote Control Installation

### **WARNING**

**DO NOT** operate the unit with wet hands, as this could lead to electrical shock.

### Remote Control Dimensions

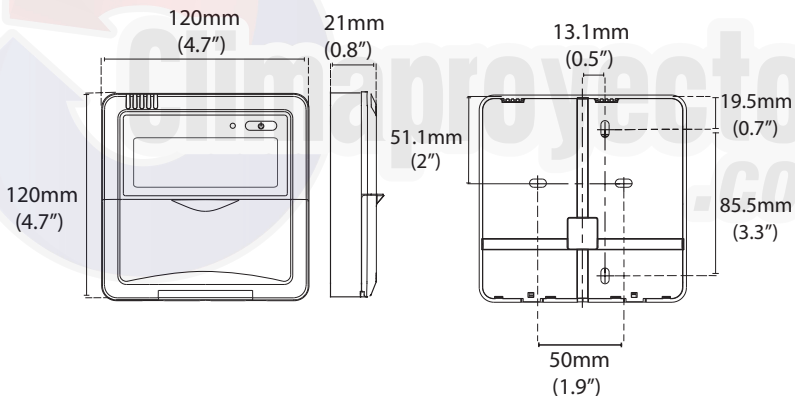

MODEL A  
Fig. 7a

## Remote Control Dimensions

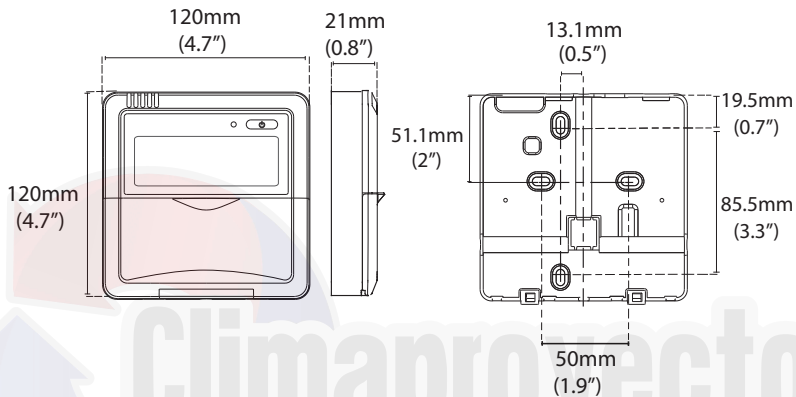

MODEL B

Fig. 7b

## Preparation Before Installation

1. Ensure you have the following parts

Table 1

No	Name	Quantity	Remarks
1	Remote Control	1	
2	Screws	3	M4X20 (For mounting on the wall)
3	Anchors	3	For mounting on the wall
4	Screws	2	M4X25 (For mounting on switch box)
5	Plastic screw bars	2	For fixing on switch box
6	The connective wires group	1	Optional

2. Prepare the following tools

Table 2

No	Name	Quantity
1	Switch box	1
2	Wiring tube (insulating sleeve and tightening screw)	1

3. Select installation location

**DO NOT** install the remote control near flammable liquids or gases such as gasoline or hydrogen sulfide. Doing so creates a fire hazard.

## Installation Method

1. Remove the top panel of remote control  
Insert a screwdriver into the two slots at the bottom of the remote control to pop off the top panel.

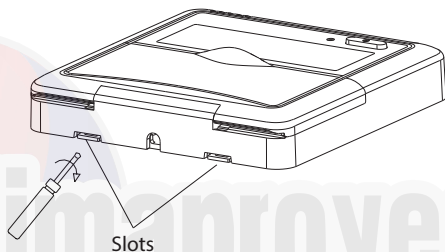
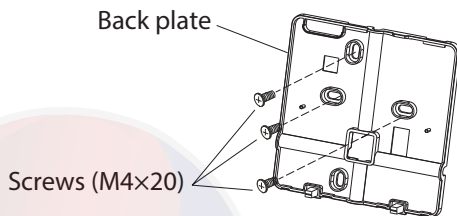

Fig. 8

**NOTE:** The Printed Circuit Board (PCB) is mounted in the upper part of the remote control. Be careful not to damage the board with the screwdriver.

2. Mount the back plate of the remote control
- a. For exposed mounting, fasten the back plate to the wall with 3 screws (M4×20) and anchors.



MODEL A

Fig. 9a

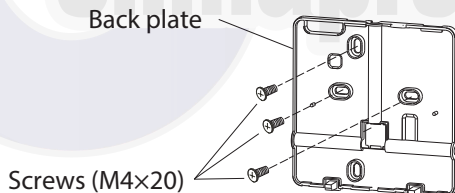

MODEL B

Fig. 9b

- b. For flush mounting, fasten the back plate to the switch box with 2 screws (M4×25), and fasten the back plate to the wall with 1 screw (M4×20).

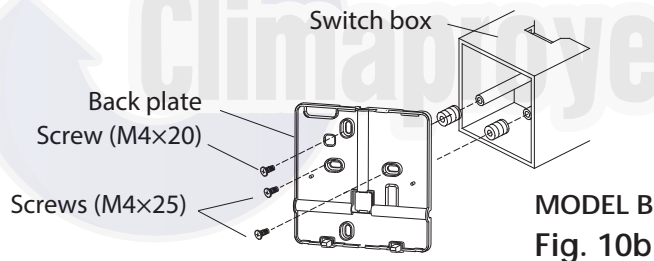
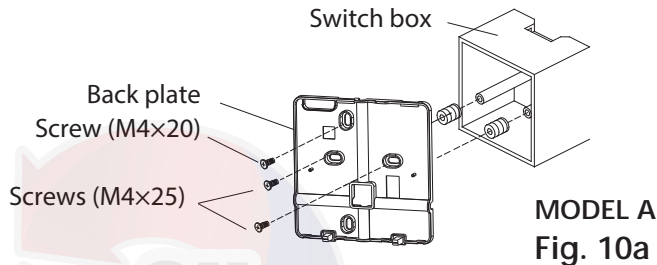

**NOTE:** Place the unit on a flat surface. Be careful not to distort the back plate of the remote control by over tightening the screws.

### 3. Set the time and date

The remote control has a small, built-in battery that allows the time and date to be set. That way the remote control can keep time even during a power outage. When the unit displays an incorrect time and date the batteries need to be replaced.

### 4. Reattach the top panel of the remote control

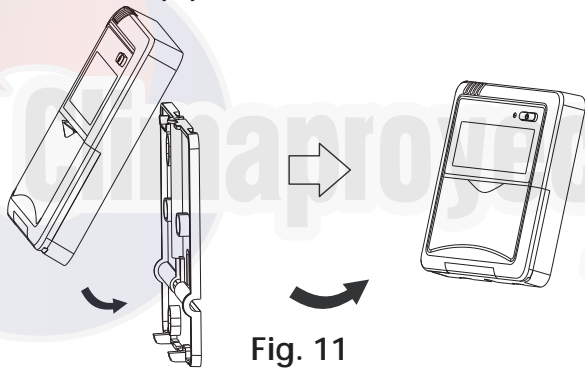

Fig. 11

## ! CAUTION

**DO NOT** clamp the wires when reattaching the top panel.

## Constant air volume testing

### (To set external static pressure) (some models)

- You can use the unit's automatic airflow adjustment function to set external static pressure.
- Automatic airflow adjustment is the volume of blow-off air that has been automatically adjusted to the quantity rated.

1. Make sure the test run is done with a dry coil. If the coil is not dry, run the unit for 2 hours in FAN ONLY mode to dry the coil.

2. Check that both power supply wiring and duct installation have been completed. Check that any closing dampers are open. Check that the air filter is properly attached to the air suction side passage of the unit.

3. Set the parameters for automatic airflow adjustment. When the air conditioning unit is off, perform the following steps:



① When the unit is turned off, hold the MODE button and FAN button down together for three seconds.

("AF" indicator flashes for 3 times.)

② Press "△" or "▽" to select the AF.

③ Press "MODE". The air conditioning unit will then start the fan for airflow automatic adjustment.

After 6 minutes, the air conditioning unit stops operating once automatic airflow adjustment has finished.

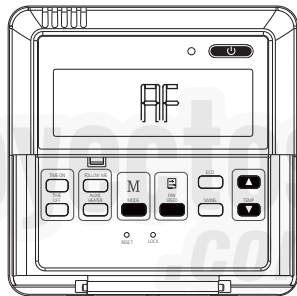

## ! CAUTION

- **DO NOT** adjust the dampers when automatic airflow adjustment is active.

## Using the wire controller to set airflow rate (some models)

When the air conditioning unit is off, perform the following steps:

- ① Press "MODE" and "FAN" for three seconds.
- ② Press "△" or "▽" to select the SP.
- ③ Press "MODE" to set the airflow rate in the range of 0~4.

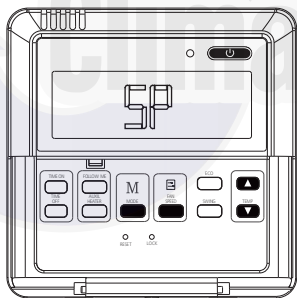

"0": No airflow change  
"1"~"4": Airflow increase progressively

- ④ Press "ON/OFF" to finish the airflow setting.

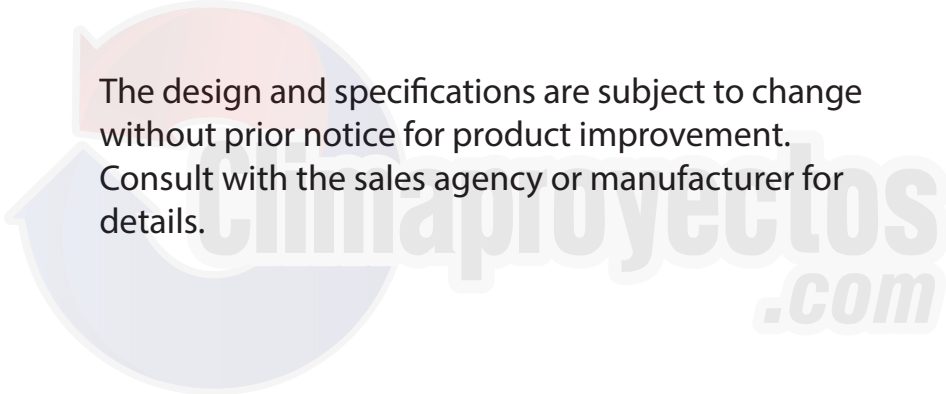

The design and specifications are subject to change without prior notice for product improvement. Consult with the sales agency or manufacturer for details.



 United Technologies  
turn to the experts 

Climaproyectos  
.com