

## 2. Specifications

Model			MDV-D22Q4/VN1-A3	MDV-D28Q4/VN1-A3
Power supply		V-ph-Hz	220-240V~1Ph~60Hz	220-240V~1Ph~60Hz
Cooling	Capacity	kW	2.2	2.8
		Btu/h	7500	9600
	Input	W	51	52
	Rated current	A	0.175	0.175
Heating	Capacity	kW	2.4	3.2
		Btu/h	8200	10900
	Input	W	43	44
Rated current	A	0.175	0.175	
Indoor fan motor	Model		YDK15-6P-4	YDK15-6P-4
	Type		AC Motor	AC Motor
	Input	W	37.8	37.8
	Capacitor	uF	0.8uF/450V	0.8uF/450V
	Speed(h/m/l)	r/min	658/586/485	658/586/485
Indoor coil	Number of rows		1	1
	Tube pitch(a)x row pitch(b)		in.(mm) 13/16×17/32(21×13.37)	13/16×17/32(21×13.37)
	Fin spacing		in.(mm) 1/16(1.5)	1/16(1.5)
	Fin type (code)		Hydrophilic aluminium	
	Tube outside dia. and type		in.(mm) 1/4(Φ6.35)	1/4(Φ6.35)
			Inner groove tube	
	Coil length x height x width		in.(mm) 51-9/16×8-9/32×17/32(1310×210×13.37)	
Number of circuits		2	2	
Indoor air flow (H/M/L)	m3/h		397/292/215	408/310/231
	CFM		234/172/127	240/182/136
Sound level (sound pressure)		dB(A)	35.8/33.4/23.4	35.8/33.4/23.4
Indoor unit	Dimension (W×H×D)		in.(mm) 22-7/16×10-15/64×22-7/16(570×265×570)	
	Packing (W×H×D)		in.(mm) 26-9/16×11-7/32×26-9/16(675×285×675)	
	Net/Gross weight		lbs. (kg) 35.3/44.1(16/20)	
Panel	Dimension (W×H×D)		in.(mm) 25-15/32×1-31/32×25-15/32 (647×50×647)	
	Packing (W×H×D)		in.(mm) 28-5/32×4-27/32×28-5/32(715×113×715)	
	Net/Gross weight		lbs. (kg) 5.5/9.9(2.5/4.5)	
Refrigerant	Type		R410a	R410a
Throttle		Electronic expansion valve		
Design pressure(H/L)		MPa	4.4/2.6	4.4/2.6
Refrigerant piping	Liquid side	in.(mm)	1/4(Φ6.35)	1/4(Φ6.35)
	Gas side	in.(mm)	1/2(Φ12.7)	1/2(Φ12.7)
Connection wiring	Power wiring	mm2	3×2.0	
	Signal wiring	mm2	3×0.5 (3-core shielded wire)	
Drainage water pipe diameter		in.(mm)	OD 63/64 (Φ25)	OD 63/64 (Φ25)
Controller		Wireless remote controller		

### Notes:

- Nominal cooling capacities are based on the following conditions: return air temperature: 80.6°F(27°C)DB,66.2°F(19°C)WB, and outdoor temperature: 95°F(35°C)DB, equivalent ref. piping: 26.25ft(8m) (horizontal)
- Nominal heating capacities are based on the following conditions: return air temperature: 68°F(20°C)DB, outdoor temperature: 44.6°F(7°C)DB,42.8°F(6°C)WB, and equivalent ref. Piping: 26.25ft(8m)(horizontal)

Model			MDV-D36Q4/VN1-A3	MDV-D45Q4/VN1-A3
Power supply		V-ph-Hz	220-240V~1Ph~60Hz	220-240V~1Ph~60Hz
Cooling	Capacity	kW	3.6	4.5
		Btu/h	12300	15400
	Input	W	58	58
	Rated current	A	0.21	0.21
Heating	Capacity	kW	4.0	5.0
		Btu/h	13600	17100
	Input	W	50	51
	Rated current	A	0.21	0.21
Indoor fan motor	Model		YDK15-6P-4	YDK15-6P-4
	Type		AC MOTOR	AC MOTOR
	Input	W	44	44
	Capacitor	uF	1.2uF/450V	1.2uF/450V
	Speed(h/m/l)	r/min	780/670/540	780/675/560
Indoor coil	Number of rows		2	2
	Tube pitch(a)x row pitch(b)	in.(mm)	13/16×17/32(21×13.37)	13/16×17/32(21×13.37)
	Fin spacing	in.(mm)	1/16(1.5)	1/16(1.5)
	Fin type (code)		Hydrophilic aluminium	
	Tube outside dia. and type	in.(mm)	1/4(Φ6.35)	1/4(Φ6.35)
			Inner groove tube	
	Coil length x height x width	in.(mm)	51-9/16×8-9/32×1-1/16(1310×210×26.74)	
Number of circuits		4	4	
Indoor air flow (H/M/L)	m3/h		496/359/263	496/359/263
	CFM		292/211/155	292/211/155
Sound level (sound pressure)		dB(A)	41.5/35.6/28.8	41.5/35.6/28.8
Indoor unit	Dimension (W× H×D)	in.(mm)	22-7/16×10-15/64×22-7/16(570×260×570)	
	Packing (W×H ×D)	in.(mm)	26-9/16×11-7/32×26-9/16(675×285×675)	
	Net/Gross weight	lbs.(kg)	39.7/48.5(18/22)	39.7/48.5(18/22)
Panel	Dimension (W× H× D)	in.(mm)	25-15/32×1-31/32×25-15/32(647×50×647)	
	Packing (W× H× D)	in.(mm)	28-5/32×4-27/32×28-5/32(715×113×715)	
	Net/Gross weight	lbs.(kg)	5.5/9.9(2.5/4.5)	
Refrigerant	Type		R410a	R410a
Throttle		Electronic expansion valve		
Design pressure(H/L)		MPa	4.4/2.6	4.4/2.6
Refrigerant piping	Liquid side	in.(mm)	1/4(Φ6.35)	1/4(Φ6.35)
	Gas side	in.(mm)	1/2(Φ12.7)	1/2(Φ12.7)
Connection wiring	Power wiring	mm <sup>2</sup>	3×2.0	3×2.0
	Signal wiring	mm <sup>2</sup>	3×0.5 (3-core shielded wire)	
Drainage water pipe diameter		in.(mm)	OD 63/64 (Φ25)	OD 63/64 (Φ25)
Controller		Wireless remote controller		

**Notes:**

- Nominal cooling capacities are based on the following conditions: return air temperature: 80.6°F(27°C)DB,66.2°F(19°C)WB, and outdoor temperature: 95°F(35°C)DB, equivalent ref. piping: 26.25ft(8m) (horizontal)
- Nominal heating capacities are based on the following conditions: return air temperature: 68°F(20°C)DB, outdoor temperature: 44.6°F(7°C)DB,42.8°F(6°C)WB, and equivalent ref. Piping: 26.25ft(8m)(horizontal)

### 3. Dimensions

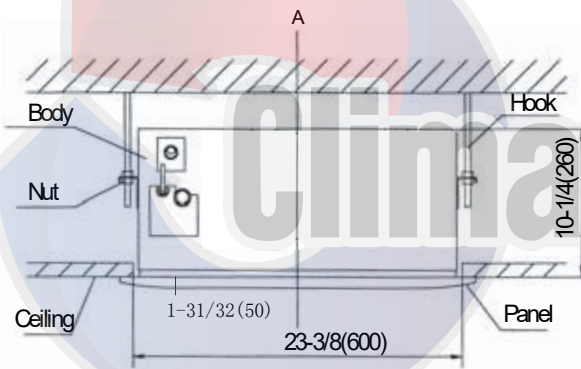
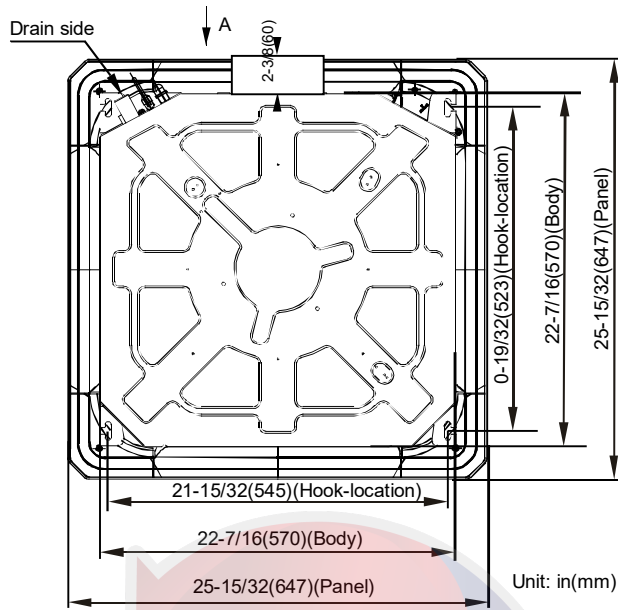

Clima proyectos