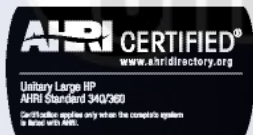
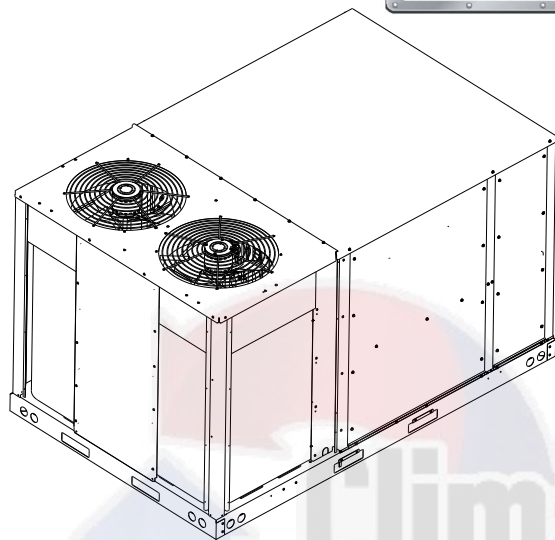

DBC/DBH SERIES LIGHT COMMERCIAL PACKAGED HEATING AND COOLING UNIT 7.5T TO 12.5T

INSTALLATION INSTRUCTIONS

**WARNING**

ONLY PERSONNEL THAT HAVE BEEN TRAINED TO INSTALL, ADJUST, SERVICE OR REPAIR (HEREINAFTER, "SERVICE") THE EQUIPMENT SPECIFIED IN THIS MANUAL SHOULD SERVICE THE EQUIPMENT. THE MANUFACTURER WILL NOT BE RESPONSIBLE FOR ANY INJURY OR PROPERTY DAMAGE ARISING FROM IMPROPER SERVICE OR SERVICE PROCEDURES. IF YOU SERVICE THIS UNIT, YOU ASSUME RESPONSIBILITY FOR ANY INJURY OR PROPERTY DAMAGE WHICH MAY RESULT. IN ADDITION, IN JURISDICTIONS THAT REQUIRE ONE OR MORE LICENSES TO SERVICE THE EQUIPMENT SPECIFIED IN THIS MANUAL, ONLY LICENSED PERSONNEL SHOULD SERVICE THE EQUIPMENT. IMPROPER INSTALLATION, ADJUSTMENT, SERVICING OR REPAIR OF THE EQUIPMENT SPECIFIED IN THIS MANUAL, OR ATTEMPTING TO INSTALL, ADJUST, SERVICE OR REPAIR THE EQUIPMENT SPECIFIED IN THIS MANUAL WITHOUT PROPER TRAINING MAY RESULT IN PRODUCT DAMAGE, PROPERTY DAMAGE, PERSONAL INJURY OR DEATH.

**PROP 65 WARNING
FOR CALIFORNIA CONSUMERS****WARNING**

Cancer and Reproductive Harm -
www.P65Warnings.ca.gov

0140M00517-A

Our continuing commitment to quality products may mean a change in specifications without notice.

©2020 **DAIKIN MANUFACTURING COMPANY, L.P.**

19001 Kermier Rd., Waller, TX 77484

www.daikincomfort.com



INDEX

REPLACEMENT PARTS	2
SAFETY INSTRUCTIONS	2
GENERAL INFORMATION	3
CLEARANCES	5
ROOF CURB POST-INSTALLATION CHECKS	5
ROOF TOP DUCT CONNECTIONS	5
RIGGING DETAILS	6
WEIGHTS AND CENTER OF GRAVITY	7
ELECTRICAL WIRING	8
CIRCULATING AIR AND FILTERS	10
CONDENSATE DRAIN CONNECTION	10
STARTUP, ADJUSTMENTS, AND CHECKS	10
AIR FLOW ADJUSTMENTS	12
BELT DRIVE MODELS ONLY	12
MOTOR SHEAVE ADJUSTMENTS	13
HEAT PUMP OPERATION	16
MAINTENANCE	17
TROUBLESHOOTING	18
APPENDIX A BLOWER PERFORMANCE DATA	19
APPENDIX B ELECTRICAL DATA	27
APPENDIX C UNIT DIMENSIONS	40
APPENDIX D MIN-MAX AIRFLOW	41
WIRING DIAGRAM	42
START-UP CHECKLIST	44

REPLACEMENT PARTS

ORDERING PARTS

When reporting shortages or damages, or ordering repair parts, give the complete unit model and serial numbers as stamped on the unit's nameplate.

Replacement parts for this appliance are available through your contractor or local distributor. Your nearest distributor can be located online at www.daikinac.com or by contacting:

EQUIPMENT SUPPORT
Daikin North America LLC
 19001 Kermier Road
 Waller, Texas 77484
 855-770-5678

SAFETY INSTRUCTIONS



RECOGNIZE THIS SYMBOL AS A SAFETY PRECAUTION.

These installation instructions cover the outdoor installation of single package heating and cooling units. See the Specification Sheet applicable to your model for information regarding accessories.

***NOTE: PLEASE CONTACT YOUR DISTRIBUTOR OR OUR WEBSITE FOR THE APPLICABLE SPECIFICATION SHEET REFERRED TO IN THIS MANUAL.**

TO THE INSTALLER

Before installing this unit, please read this manual to familiarize yourself on the specific items which must be adhered to, including maximum external static pressure to unit, air temperature rise, minimum or maximum CFM and motor speed connections.

Keep this literature in a safe place for future reference.



WARNING

TO PREVENT THE RISK OF PROPERTY DAMAGE, PERSONAL INJURY, OR DEATH, DO NOT STORE COMBUSTIBLE MATERIALS OR USE GASOLINE OR OTHER FLAMMABLE LIQUIDS OR VAPORS IN THE VICINITY OF THIS APPLIANCE.



CAUTION

SHEET METAL PARTS, SCREWS, CLIPS AND SIMILAR ITEMS INHERENTLY HAVE SHARP EDGES, AND IT IS NECESSARY THAT THE INSTALLER AND SERVICE PERSONNEL EXERCISE CAUTION.



WARNING

DO NOT CONNECT TO OR USE ANY DEVICE THAT IS NOT DESIGN CERTIFIED BY THE MANUFACTURER FOR USE WITH THIS UNIT. SERIOUS PROPERTY DAMAGE, PERSONAL INJURY, REDUCED UNIT PERFORMANCE AND/OR HAZARDOUS CONDITIONS MAY RESULT FROM THE USE OF SUCH NON-APPROVED DEVICES.



WARNING

THIS UNIT MUST NOT BE USED AS A "CONSTRUCTION HEATER" DURING THE FINISHING PHASES OF CONSTRUCTION ON A NEW STRUCTURE. THIS TYPE OF USE MAY RESULT IN PREMATURE FAILURE OF THE UNIT DUE TO EXTREMELY LOW RETURN AIR TEMPERATURE AND EXPOSURE TO CORROSIVE OR VERY DIRTY ATMOSPHERES.



WARNING

HIGH VOLTAGE! DISCONNECT ALL POWER BEFORE SERVICING OR INSTALLING THIS UNIT. MULTIPLE POWER SOURCES MAY BE PRESENT. FAILURE TO DO SO MAY CAUSE PROPERTY DAMAGE, PERSONAL INJURY OR DEATH.



GENERAL INFORMATION



WARNING

TO PREVENT PROPERTY DAMAGE, PERSONAL INJURY OR DEATH, DUE TO FIRE, EXPLOSIONS, SMOKE, SOOT, CONDENSATION, ELECTRIC SHOCK OR CARBON MONOXIDE, THIS UNIT MUST BE PROPERLY INSTALLED, REPAIRED, OPERATED, AND MAINTAINED.

This unit is approved for outdoor installation ONLY.

Rated performance is achieved after 20 hours of operation. Rated performance is delivered at the specified airflow. See outdoor unit specification sheet for split system models or product specification sheet for packaged and light commercial models. Specification sheets can be found at www.daikinac.com for Daikin brand products. Within the website, please select the residential or commercial products menu and then select the submenu for the type of product to be installed, such as air conditioners or heat pumps, to access a list of product pages that each contain links to that model's specification sheet.

EPA REGULATIONS

IMPORTANT: THE UNITED STATES ENVIRONMENTAL PROTECTION AGENCY (EPA) HAS ISSUED VARIOUS REGULATIONS REGARDING THE INTRODUCTION AND DISPOSAL OF REFRIGERANTS IN THIS UNIT. FAILURE TO FOLLOW THESE REGULATIONS MAY HARM THE ENVIRONMENT AND CAN LEAD TO THE IMPOSITION OF SUBSTANTIAL FINES. BECAUSE REGULATIONS MAY VARY DUE TO PASSAGE OF NEW LAWS, WE SUGGEST A CERTIFIED TECHNICIAN PERFORM ANY WORK DONE ON THIS UNIT. SHOULD YOU HAVE ANY QUESTIONS PLEASE CONTACT THE LOCAL OFFICE OF THE EPA.

NATIONAL CODES

This product is designed and manufactured to permit installation in accordance with National Codes. It is the installer's responsibility to install the product in accordance with National Codes and/or prevailing local codes and regulations.

The heating and cooling capacities of the unit should be greater than or equal to the design heating and cooling loads of the area to be conditioned. The loads should be calculated by an approved method or in accordance with ASHRAE Guide or Manual J - Load Calculations published by the Air Conditioning Contractors of America.

Obtain from:

American National Standards Institute
www.ansi.org

System design and installation should also, where applicable, follow information presented in accepted industry guides such as the ASHRAE Handbooks. The manufacturer assumes no responsibility for equipment installed in violation of any code or regulation. The mechanical installation of the packaged roof top units consists of making final connections between the unit and building services; supply and return duct connections; and drain connections (if required). The internal systems of the unit are completely factory-installed and tested prior to shipment.

Units are generally installed on a steel roof mounting curb assembly which has been shipped to the job site for installation on the roof structure prior to the arrival of the unit. The model number shown on the unit's identification plate identifies the various components of the unit such as refrigeration tonnage, heating input and voltage.

Carefully inspect the unit for damage including damage to the cabinetry. Any bolts or screws which may have loosened in transit must be re-tightened.

In the event of damage, the receiver should:

1. Make notation on delivery receipt of any visible damage to shipment or container.
2. Notify carrier promptly and request an inspection.
3. In case of concealed damage, carrier should be notified as soon as possible-preferably within 5 days.
4. File the claim with the following supporting documents:
 - a. Original Bill of Lading, certified copy, or indemnity bond.
 - b. Original paid freight bill or indemnity in lieu thereof.
 - c. Original invoice or certified copy thereof, showing trade and other discounts or reductions.
 - d. Copy of the inspection report issued by carrier representative at the time damage is reported to the carrier. The carrier is responsible for making prompt inspection of damage and for a thorough investigation of each claim. The distributor or manufacturer will not accept claims from dealers for transportation damage.

NOTE: WHEN INSPECTING THE UNIT FOR TRANSPORTATION DAMAGE, REMOVE ALL PACKAGING MATERIALS. RECYCLE OR DISPOSE OF THE PACKAGING MATERIAL ACCORDING TO LOCAL CODES.

PRE-INSTALLATION CHECKS

Carefully read all instructions for the installation prior to installing unit. Ensure each step or procedure is understood and any special considerations are taken into account before starting installation. Assemble all tools, hardware and supplies needed to complete the installation. Some items may need to be purchased locally.



WARNING

TO PREVENT POSSIBLE EQUIPMENT DAMAGE, PROPERTY DAMAGE, PERSONAL INJURY OR DEATH, THE FOLLOWING BULLET POINTS MUST BE OBSERVED WHEN INSTALLING THE UNIT.

IMPORTANT NOTE: REMOVE WOOD SHIPPING RAILS PRIOR TO INSTALLATION OF THE UNIT.

ALL INSTALLATIONS:

IMPORTANT NOTE: UNIT SHOULD BE ENERGIZED 24 HOURS PRIOR TO COMPRESSOR START UP TO ENSURE CRANKCASE HEATER HAS SUFFICIENTLY WARMED THE COMPRESSORS. COMPRESSOR DAMAGE MAY OCCUR IF THIS STEP IS NOT FOLLOWED.

NOTE: APPLIANCE IS SHIPPED FROM FACTORY FOR VERTICAL DUCT APPLICATION.

Proper installation of the unit ensures trouble-free operation. Improper installation can result in problems ranging from noisy operation to property or equipment damages, dangerous conditions that could result in injury or personal property damage and that are not covered by the warranty. Give this booklet to the user and explain it's provisions. The user should retain these instructions for future reference.

- To avoid possible illness or death of the building occupants, do NOT locate outside air intake device (economizer, manual fresh air intake, motorized fresh air intake) too close to an exhaust outlet, gas vent termination, or plumbing vent outlet. For specific distances required, consult local codes.
- Allow minimum clearances from the enclosure for fire protection, proper operation, and service access (see unit clearances). These clearances must be permanently maintained.
- When the unit is heating, the temperature of the return air entering the unit must be a minimum of 55° F.

GROUND LEVEL INSTALLATIONS ONLY:

- When the unit is installed on the ground adjacent to the building, a level concrete (or equal) base is recommended. Prepare a base that is 3" larger than the package unit footprint and a minimum of 3" thick.
- The base should also be located where no runoff of water from higher ground can collect in the unit.

ROOF TOP INSTALLATIONS ONLY:

- To avoid possible property damage or personal injury, the roof must have sufficient structural strength to carry the weight of the unit(s) and snow or water loads as required by local codes. Consult a structural engineer to determine the weight capabilities of the roof.
- The unit may be installed directly on wood floors or on Class A, Class B, or Class C roof covering material.

- To avoid possible personal injury, a safe, flat surface for service personnel should be provided.
- As indicated on the unit data plate, a minimum clearance of 36" to any combustible material is required on the furnace access side of the unit. All combustible materials must be kept out of this area.
- This 36" clearance must also be maintained to insure proper combustion air and flue gas flow. The combustion air intake and furnace flue discharge must not be blocked for any reason, including blockage by snow.
- Adequate clearances from the furnace flue discharge to any adjacent public walkways, adjacent buildings, building openings or openable windows must be maintained in accordance with the latest edition of the National Fuel Gas Code ANSI Z223.1/NFPA 54.
- Minimum horizontal clearance of 48" from the furnace flue discharge to any electric meters, gas meters, regulators and relief equipment is required.

UNIT PRECAUTIONS

- Do not stand or walk on the unit.
- Do not drill holes anywhere in panels or in the base frame of the unit except where indicated. Unit access panels provide structural support.
- Do not remove any access panels until unit has been installed on roof curb or field supplied structure.
- Do not roll unit across finished roof without prior approval of owner or architect.
- Do not skid or slide on any surface as this may damage unit base. The unit must be stored on a flat, level surface. Protect the condenser coil because it is easily damaged.

ROOF CURB INSTALLATIONS ONLY:

Curb installations must comply with local codes and should be done in accordance with the established guidelines of the National Roofing Contractors Association.

Proper unit installation requires that the roof curb be firmly and permanently attached to the roof structure. Check for adequate fastening method prior to setting the unit on the curb.

Full perimeter roof curbs are available from the factory and are shipped unassembled. Field assembly, squaring, leveling and mounting on the roof structure are the responsibility of the installing contractor. All required hardware necessary for the assembly of the sheet metal curb is included in the curb accessory.



WARNING

TO PREVENT POSSIBLE EQUIPMENT DAMAGE, PROPERTY DAMAGE, PERSONAL INJURY OR DEATH, THE FOLLOWING BULLET POINTS MUST BE OBSERVED WHEN INSTALLING THE UNIT.

- Sufficient structural support must be determined prior to locating and mounting the curb and package unit.
- Ductwork must be constructed using industry guidelines. The duct work must be placed into the roof curb before mounting the package unit. Our full perimeter curbs include duct connection frames to be assembled with the curb. Cantilevered type curbs are not available from the factory.
- Curb insulation, cant strips, flashing and general roofing material are furnished by the contractor.
- The curbs must be supported on parallel sides by roof members.
- The roof members must not penetrate supply and return duct opening areas as damage to the unit might occur.

made to deflect the warm discharge air out from the overhang. The unit should be installed remote from all building exhausts to inhibit ingestion of exhaust air into the unit fresh air intake.

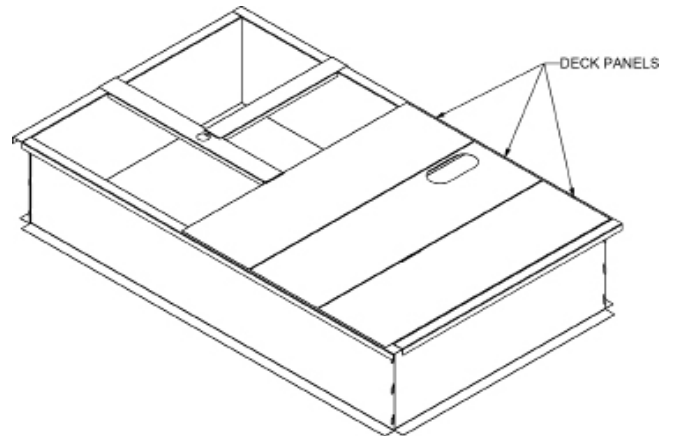

ROOF CURB INSTALLATION

NOTE: THE UNIT AND CURB ACCESSORIES ARE DESIGNED TO ALLOW VERTICAL DUCT INSTALLATION BEFORE UNIT PLACEMENT. DUCT INSTALLATION AFTER UNIT PLACEMENT IS NOT RECOMMENDED.

CAUTION

ALL CURBS LOOK SIMILAR. TO AVOID INCORRECT CURB POSITIONING, CHECK JOB PLANS CAREFULLY AND VERIFY MARKINGS ON CURB ASSEMBLY. INSTRUCTIONS MAY VARY IN CURB STYLES AND SUPERSEDES INFORMATION SHOWN.

See the manual shipped with the roof curb for assembly and installation instructions.

CLEARANCES

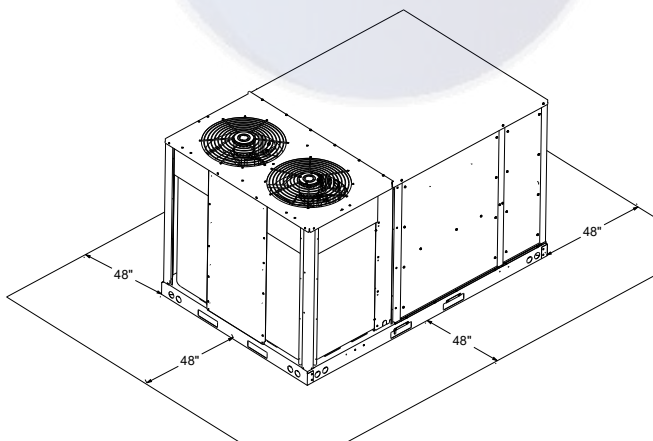

UNIT CLEARANCES

**In situations that have multiple units, a 48" minimum clearance is required between the condenser coils.* Adequate clearance around the unit should be kept for safety, service, maintenance, and proper unit operation. A clearance of 48" is recommended on all sides of the unit to facilitate possible parts replacement, to allow service access and to insure proper ventilation and condenser airflow. The top of the unit should be completely unobstructed. If units are to be located under an overhang, there should be a minimum of 48" clearance and provisions

ROOF CURB POST-INSTALLATION CHECKS

After installation, check the top of the curb, duct connection frame and duct flanges to make sure gasket has been applied properly. Gasket should be firmly applied to the top of the curb perimeter, duct flanges and any exposed duct connection frame. If gasket is loose, re-apply using strong weather resistant adhesive.

Knocked Down Roof Curbs		
UNIT TONNAGE	DESCRIPTION	PART NUMBER
7.5 to 12.5	Curb 14" Tall	0270L01153
	Curb 24" Tall	0270L01154

PROTRUSION

Inspect curb to ensure that none of the utility services (electric) routed through the curb protrude above the curb.

CAUTION

IF PROTRUSIONS EXIST, DO NOT ATTEMPT TO SET UNIT ON CURB.

ROOF TOP DUCT CONNECTIONS

Install all duct connections on the unit before placing the unit on rooftop.

HORIZONTAL DISCHARGE

Refer to IOD-7082 included in the literature pack for installing horizontal duct covers.

Flexible duct connectors between the unit and ducts are recommended. Insulate and weatherproof all external ductwork and joints as required and in accordance with local codes.

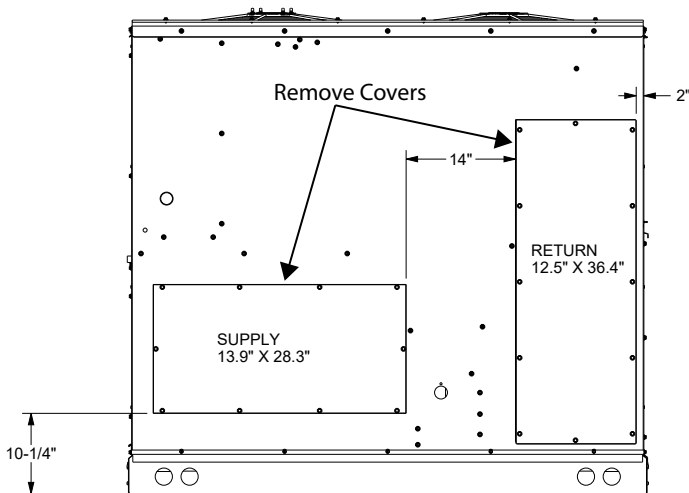

HORIZONTAL DISCHARGE DUCT CONNECTIONS

RIGGING DETAILS

- Two spreader bars must span over the unit to prevent damage to the cabinet by the lift cables. Spreader bars must be of sufficient length so that cables do not come in contact with the unit during transport. Remove wood struts mounted beneath unit base frame before setting unit on roof curb. These struts are intended to protect unit base frame from fork lift damage. Removal is accomplished by extracting the sheet metal retainers and pulling the struts through the base of the unit. Refer to rigging label on the unit.
- Your unit may be equipped with a steel shipping brace located underneath the unit (under compressors). If installing on a roof curb, the brace **MUST** be removed. Follow the following instructions for removal.

	CAUTION
<p>WHEN UNIT IS SUSPENDED, BOARDS AND SHIPPING BRACE WILL DROP WHEN SCREWS ARE REMOVED. TO PREVENT PERSONAL INJURY, STAND CLEAR. REMOVE FORK HOLE BRACKETS, BOARDS AND SHIPPING BRACE FROM BOTTOM OF UNIT BEFORE PLACING UNIT ONTO CURB.</p>	

BEFORE INSTALLING THIS UNIT ON A ROOF CURB:

1. Remove wooden struts per installation instructions. *These are the struts that are located in the fork holes and are used to protect the unit from damage while lifting with forks.*
2. Locate and remove the four (4) screws that attach the shipping brace to the side rails. There will be two (2) screws on each side of the unit. *See following figure.*

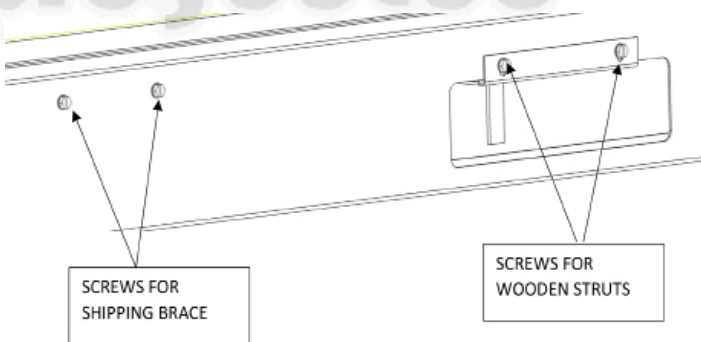

3. Lift unit per the "Rigging Details" section of the installation instructions, observing all warnings and cautions. Lift the unit high enough off the ground to reach under and grasp the shipping brace.
4. Rotate the brace by tapping the ends until the brace falls free from the unit.
5. Dispose of the brace appropriately.

IMPORTANT: IF USING BOTTOM DISCHARGE WITH ROOF CURB, DUCTWORK SHOULD BE ATTACHED TO THE CURB PRIOR TO INSTALLING THE UNIT. DUCTWORK DIMENSIONS ARE SHOWN IN ROOF CURB INSTALLATION INSTRUCTIONS.

	WARNING
<p>TO PREVENT PROPERTY DAMAGE, THE UNIT SHOULD REMAIN IN AN UPRIGHT POSITION DURING ALL RIGGING AND MOVING OPERATIONS. TO FACILITATE LIFTING AND MOVING WHEN A CRANE IS USED, PLACE THE UNIT IN AN ADEQUATE CABLE SLING.</p>	

	CAUTION
<p>DO NOT LIFT UNITS TWO AT A TIME. PROVISIONS FOR FORKS HAVE BEEN INCLUDED IN THE UNIT BASE FRAME. MINIMUM FORK LENGTH IS 72" TO PREVENT DAMAGE TO THE UNIT.</p>	

PROVISIONS FOR FORKS HAVE BEEN INCLUDED IN THE UNIT BASE FRAME. NO OTHER FORK LOCATIONS ARE APPROVED.

	WARNING
<p>TO PREVENT POSSIBLE EQUIPMENT DAMAGE, PROPERTY DAMAGE, PERSONAL INJURY OR DEATH, THE FOLLOWING BULLET POINTS MUST BE OBSERVED WHEN INSTALLING THE UNIT.</p>	

- Unit must be lifted by the four lifting holes located at the base frame corners.
- Lifting cables should be attached to the unit with shackles.
- The distance between the crane hook and the top of the unit must not be less than 60".

Refer to the Roof Curb Installation Instructions for proper curb installation. Curbing must be installed in compliance with the National Roofing Contractors Association Manual.

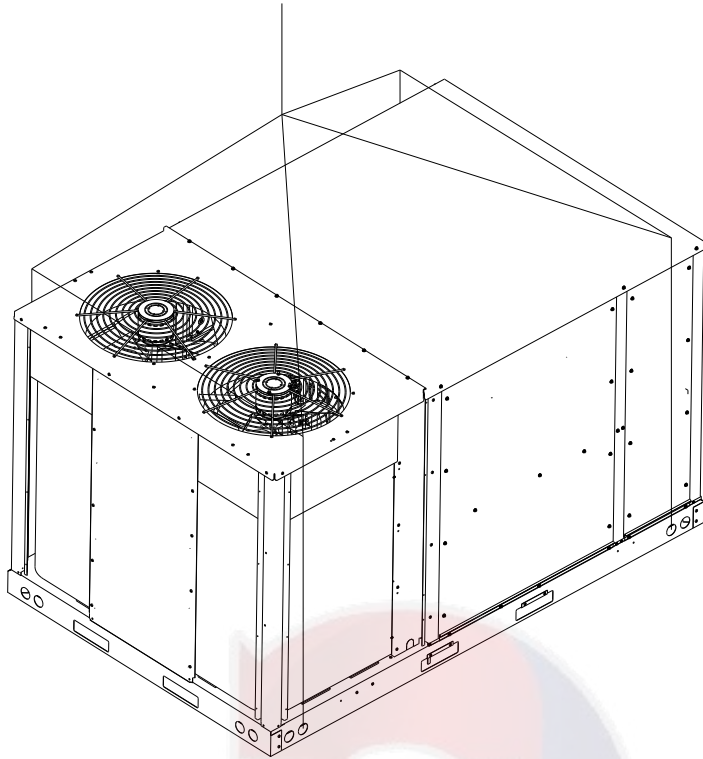

Data	DBC Weights (lbs)			
	090	102	120	150
Corner Weight- A	154	205	166	211
Corner Weight- B	339	315	331	381
Corner Weight- C	229	273	224	289
Corner Weight- D	373	313	349	327
Unit Shipping Weight	1095	1106	1150	1288
Unit Operating Weight	1015	1026	1070	1208
X (Inches)	44	49	45	41
Y (Inches)	27	28	30	28

Data	DBH Weights (lbs)			
	090	102	120	150
Corner Weight - A	224	254	265	302
Corner Weight - B	359	347	344	401
Corner Weight - C	267	300	317	312
Corner Weight - D	302	311	290	379
Unit Shipping Weight	1227	1287	1291	1394
Unit Operating Weight	1152	1212	1216	1314
X (inches)	43	44	43	42
Y (inches)	31	30	30	29

THE NUMBERS MAY SLIGHTLY VARY DEPENDING ON INSTALLED OPTIONS. THESE WEIGHTS ARE WITHOUT ACCESSORIES INSTALLED.

To assist in determining rigging requirements, unit weights and center of gravity are shown as follows:

WEIGHTS AND CENTER OF GRAVITY

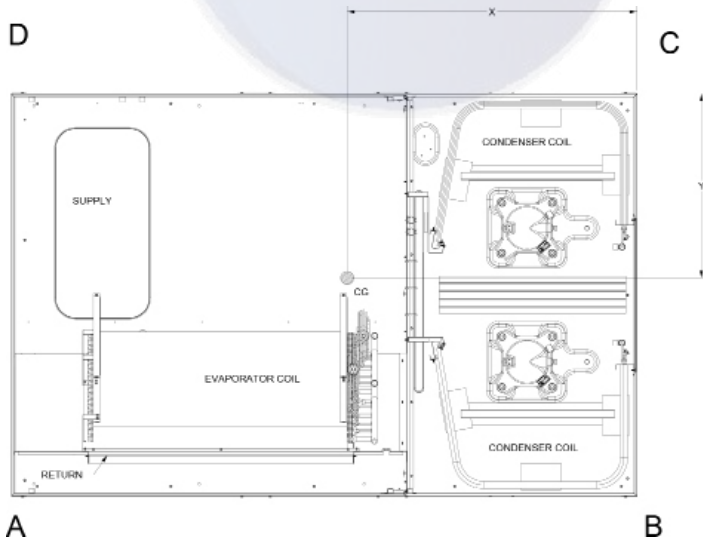

CORNER AND CENTER OF GRAVITY LOCATIONS

NOTE: UNIT SHOULD BE LIFTED AT A POINT ABOVE CENTER OF GRAVITY.

CAUTION

TO PREVENT SEVERE DAMAGE TO THE BOTTOM OF THE UNIT, DO NOT FORK LIFT UNIT AFTER WOOD STRUTS HAVE BEEN REMOVED.

Bring condenser end of unit into alignment with the curb first. Lower unit carefully onto roof mounting curb. When a rectangular cantilever curb is used, care should be taken to center the unit. Check for proper alignment and orientation of supply and return openings with duct.



RIGGING REMOVAL



CAUTION

TO PREVENT DAMAGE TO THE UNIT, DO NOT ALLOW CRANE HOOKS AND SPREADER BARS TO REST ON THE ROOF OF THE UNIT.

Remove spreader bars, lifting cables and other rigging equipment.

ELECTRICAL WIRING

 WARNING	
HIGH VOLTAGE! DISCONNECT ALL POWER BEFORE SERVICING OR INSTALLING THIS UNIT. MULTIPLE POWER SOURCES MAY BE PRESENT. FAILURE TO DO SO MAY CAUSE PROPERTY DAMAGE, PERSONAL INJURY OR DEATH.	

 WARNING	
HIGH VOLTAGE! TO AVOID PERSONAL INJURY OR DEATH DUE TO ELECTRICAL SHOCK, DO NOT TAMPER WITH FACTORY WIRING. THE INTERNAL POWER AND CONTROL WIRING OF THESE UNITS ARE FACTORY-INSTALLED AND HAVE BEEN THOROUGHLY TESTED PRIOR TO SHIPMENT. CONTACT YOUR LOCAL REPRESENTATIVE IF ASSISTANCE IS REQUIRED.	

 CAUTION
TO PREVENT DAMAGE TO THE WIRING, PROTECT WIRING FROM SHARP EDGES. FOLLOW NATIONAL ELECTRICAL CODE AND ALL LOCAL CODES AND ORDINANCES. DO NOT ROUTE WIRES THROUGH REMOVABLE ACCESS PANELS.

 CAUTION
CONDUIT AND FITTINGS MUST BE WEATHER-TIGHT TO PREVENT WATER ENTRY INTO THE BUILDING.

For unit protection, use a fuse or HACR circuit breaker that is in excess of the circuit ampacity, but less than or equal to the maximum overcurrent protection device. DO NOT EXCEED THE MAXIMUM OVERCURRENT DEVICE SIZE SHOWN ON UNIT DATA PLATE.

All line voltage connections must be made through weatherproof fittings. All exterior power supply and ground wiring must be in approved weatherproof conduit.

The main power supply wiring to the unit and low voltage wiring to accessory controls must be done in accordance with these instructions, the latest edition of the National Electrical Code (ANSI/NFPA 70), and all local codes and ordinances.

The main power supply shall be three-phase, three wire.

The unit is factory wired for the voltage shown on the unit's data plate.

NOTE: IF SUPPLY VOLTAGE IS 208V, LEAD ON PRIMARY OF TRANSFORMER(S) MUST BE MOVED FROM THE 230V TO THE 208V TAP. REFER TO WIRING DIAGRAM ON UNIT FOR DETAILS.

Main power wiring should be sized for the minimum circuit ampacity shown on the unit's database. Size wires in accordance with the ampacity tables in Article 310 of the National Electrical Code. If long wires are required, it may be necessary to increase the wire size to prevent excessive voltage drop. Wires should be sized for a maximum of 3% voltage drop.

 CAUTION
TO AVOID RISK OF PROPERTY DAMAGE, PERSONAL INJURY OR FIRE, USE ONLY COPPER CONDUCTORS.

 CAUTION
TO PREVENT IMPROPER AND DANGEROUS OPERATION DUE TO WIRING ERRORS, LABEL ALL WIRES PRIOR TO DISCONNECTION WHEN SERVICING CONTROLS. VERIFY PROPER OPERATION AFTER SERVICING.

NOTE: A WEATHER-TIGHT DISCONNECT SWITCH, PROPERLY SIZED FOR THE UNIT TOTAL LOAD, MUST BE FIELD OR FACTORY INSTALLED. AN EXTERNAL FIELD SUPPLIED DISCONNECT MAY BE MOUNTED ON THE EXTERIOR PANEL.

Ensure the data plate is not covered by the field-supplied disconnect switch.

- Some disconnect switches are not fused. Protect the power leads at the point of distribution in accordance with the unit data plate.
- The unit must be electrically grounded in accordance with local codes or, in the absence of local codes, with the latest edition of the National Electrical Code ANSI/NFPA 70, and/or the Canadian Electrical Code, CSA C22.1, Part 1. A ground lug is provided for this purpose. Do not use the ground lug for connecting a neutral conductor.
- Connect power wiring to the electrical power block located within the main control box.

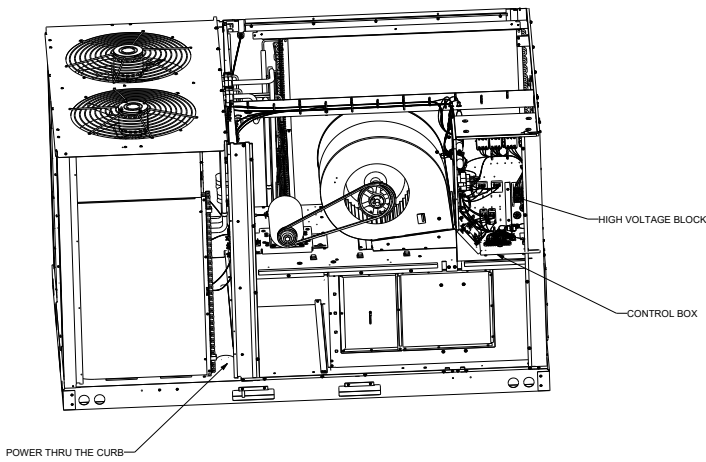

UNITS INSTALLED ON ROOF TOPS

Main power and low voltage wiring may enter the unit through the condenser end of unit or through the roof curb. Install conduit connectors at the desired entrance locations. External connectors must be weatherproof. All holes in the unit base must be sealed (including those around conduit nuts) to prevent water leakage into building. All required conduit and fittings are to be field supplied.

Supply voltage to roof top unit must not vary by more than 10% of the value indicated on the unit data plate. Phase voltage unbalance must not exceed 2%. Contact your local power company for correction of improper voltage or phase unbalance.

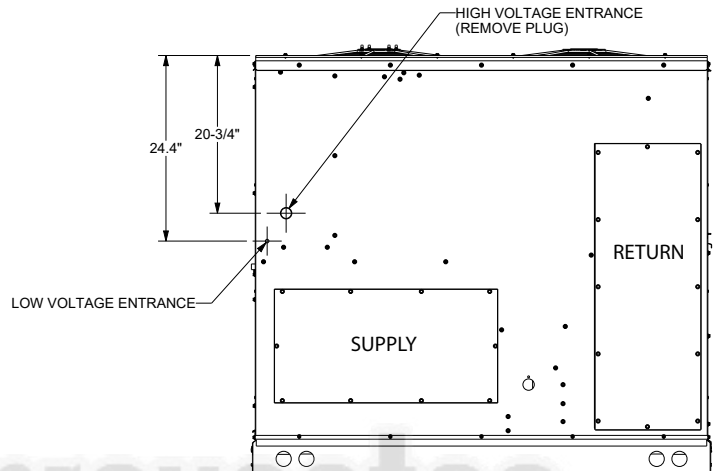
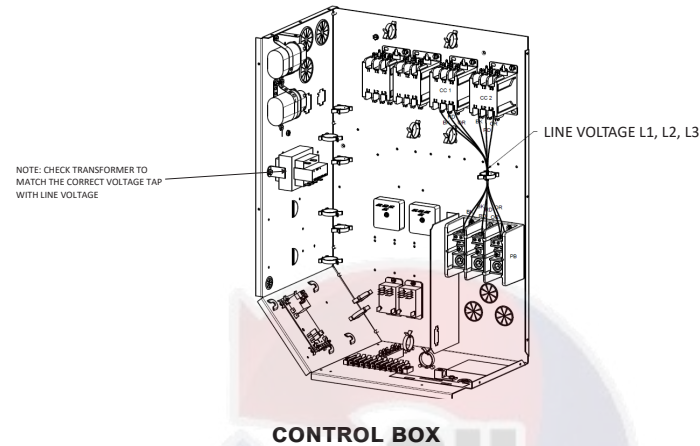

NOTE: DEPENDING ON THE OPTIONS INSTALLED, THE LOCATION OF THE COMPONENTS MAY VARY IN SOME MODELS.

WARNING

FAILURE OF UNIT DUE TO OPERATION ON IMPROPER LINE VOLTAGE OR WITH EXCESSIVE PHASE UNBALANCE CONSTITUTES PRODUCT ABUSE AND WILL VOID YOUR WARRANTY AND MAY CAUSE SEVERE DAMAGE TO THE UNIT ELECTRICAL COMPONENTS.

AREAS WITHOUT CONVENIENCE OUTLET

It is recommended that an independent 115V power source be brought to the vicinity of the roof top unit for portable lights and tools used by the service mechanic.

NOTE: REFER TO LOCAL CODES FOR REQUIREMENTS. THESE OUTLETS CAN ALSO BE FACTORY INSTALLED.

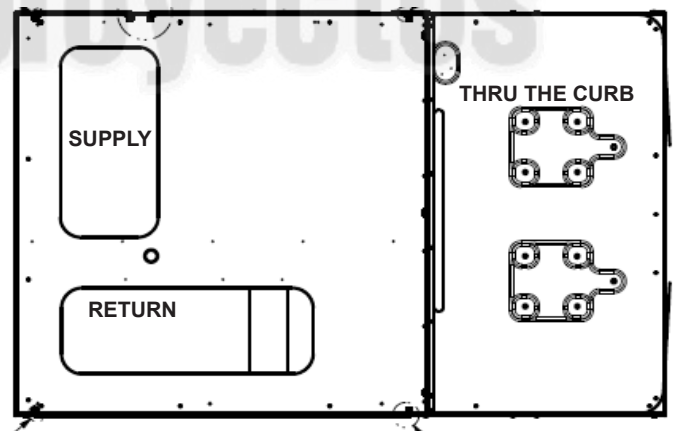

ELECTRICAL ENTRANCE AND THRU CURB

LOW VOLTAGE CONTROL WIRING

1. A 24V thermostat must be installed for unit operation.
2. Locate thermostat or remote sensor in the conditioned space where it will sense average temperature. Do not locate the device where it may be directly exposed to supply air, sunlight or other sources of heat. Follow installation instructions packaged with the thermostat.
3. Use #18 AWG wire for 24V control wiring runs not exceeding 75 feet. Use #16 AWG wire for 24V control wiring runs not exceeding 125 feet. Use #14 AWG wire for 24V control wiring runs not exceeding 200 feet. Low voltage wiring may be National Electrical Code (NEC) Class 2 where permitted by local codes.

- Route thermostat wires from sub-base terminals to the unit. Control wiring should enter through the condenser panel opening or through curb indicated in "Electrical Entrance" figure. Connect thermostat and any accessory wiring to low voltage terminal block TB1 in the main control box.

NOTE: FIELD-SUPPLIED CONDUIT MAY NEED TO BE INSTALLED DEPENDING ON UNIT/CURB CONFIGURATION. USE #18 AWG SOLID CONDUCTOR WIRE WHENEVER CONNECTING THERMOSTAT WIRES TO TERMINALS ON SUB-BASE. DO NOT USE LARGER THAN #18 AWG WIRE. A TRANSITION TO #18 AWG WIRE MAY BE REQUIRED BEFORE ENTERING THERMOSTAT SUB-BASE.

NOTE: REFER TO UNIT WIRING DIAGRAMS FOR THERMOSTAT OR REMOTE SENSOR CONNECTIONS.

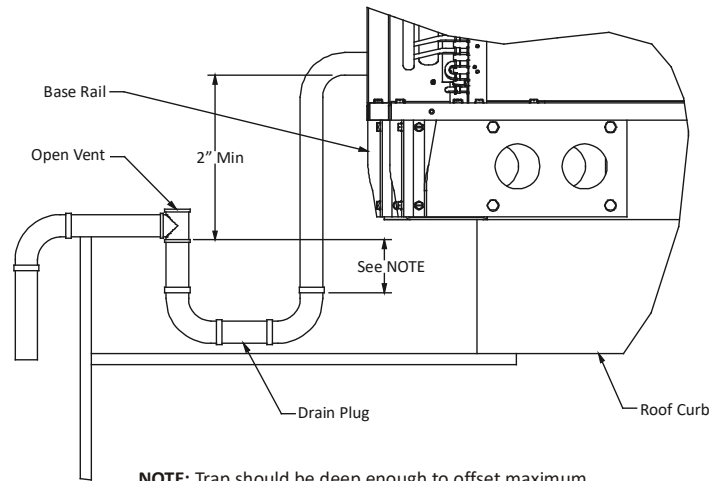

NOTE: Trap should be deep enough to offset maximum unit static difference. A minimum 4" trap is recommended.

DRAIN CONNECTION

CIRCULATING AIR AND FILTERS

DUCTWORK

The supply duct from the unit through a wall may be installed without clearance. However, minimum unit clearances must be maintained (see "Clearances" section). The supply duct should be provided with an access panel large enough to inspect the air chamber downstream of the heat exchanger. A cover should be tightly attached to prevent air leaks.

Ductwork dimensions are shown in the roof curb installation manual.

If desired, supply and return duct connections to the unit may be made with flexible connections to reduce possible unit operating sound transmission.

Install condensate drain trap as shown. Use 3/4" drain line and fittings or larger. Do not operate without trap.

HORIZONTAL DRAIN

Drainage of condensate directly onto the roof may be acceptable; refer to local code. It is recommended that a small drip pad of either stone, mortar, wood or metal be provided to prevent any possible damage to the roof.

VERTICAL DRAIN

To use the bottom drain connection, remove the drain plug from the bottom connection and install it in the horizontal connection.

CLEANING

Due to the fact that drain pans in any air conditioning unit will have some moisture in them, algae and fungus will grow due to airborne bacteria and spores. Periodic cleaning is necessary to prevent this build-up from plugging the drain. A non-chlorine cleaning agent must be used.

CONDENSATE DRAIN CONNECTION

CONDENSATE DRAIN CONNECTION

A 3/4" female NPT drain connection is supplied on the end of the unit and bottom of the drain pan for condensate piping. An external trap must be installed for proper condensate drainage. Hand tighten drain fitting to the drain connection.

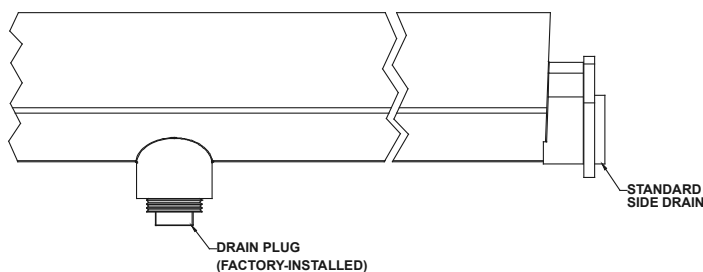

DRAIN PAN (SIDE VIEW)

STARTUP, ADJUSTMENTS, AND CHECKS

WARNING

HIGH VOLTAGE!
TO AVOID PERSONAL INJURY OR DEATH DUE TO ELECTRICAL SHOCK, BOND THE FRAME OF THIS UNIT TO THE BUILDING ELECTRICAL GROUND BY USE OF THE GROUNDING TERMINAL PROVIDED OR OTHER ACCEPTABLE MEANS. DISCONNECT ALL POWER BEFORE SERVICING OR INSTALLING THIS UNIT.

PRE-STARTUP INSTRUCTIONS - GENERAL



CAUTION

TO PREVENT PROPERTY DAMAGE OR PERSONAL INJURY, DO NOT START THE UNIT UNTIL ALL NECESSARY PRE-CHECKS AND TESTS HAVE BEEN PERFORMED.

Prior to the beginning of Startup, Adjustments, and Checks procedures, the following steps should be completed in the building.



WARNING

**MOVING MACHINERY HAZARD!
TO PREVENT POSSIBLE PERSONAL INJURY OR DEATH, DISCONNECT POWER TO THE UNIT AND PADLOCK IN THE "OFF" POSITION BEFORE SERVICING FANS.**

On new installations, or if a major component has been replaced, the operation of the unit must be checked.

Check unit operation as outlined in the following instructions. If any sparking, odors, or unusual sounds are encountered, shut off electrical power and recheck for wiring errors, or obstructions in or near the blower motors.
Duct covers must be removed before operating unit.

The Startup, Adjustments, and Checks procedure provides a step-by-step sequence which, if followed, will assure the proper startup of the equipment in the minimum amount of time. Air balancing of duct system is not considered part of this procedure. However, it is an important phase of any air conditioning system startup and should be performed upon completion of the Startup, Adjustments, and Checks procedure. The Startup, Adjustments, and Checks procedure at outside ambients below 55°F should be limited to a readiness check of the refrigeration system with the required final check and calibration left to be completed when the outside ambient rises above 55°F.

TEMPORARY HEATING OR COOLING

If the unit is to be used for temporary heating or cooling, a "Startup, Adjustments, and Checks" must first be performed in accordance with this manual. Damage or repairs due to failure to comply with these requirements are not covered under the warranty. **After** the machines are used for temporary heating or cooling, inspect the coils, fans, and motors for unacceptable levels of construction dust and dirt and install new filters.

CONTRACTOR RESPONSIBILITY

The installing contractor must be certain that:

- All supply and return air ductwork is in place, properly sealed, and corresponds with installation instructions.
- All thermostats are mounted and wired in accordance with installation instructions.

- All electric power, all gas, hot water or steam line connections, and the condensate drain installation have been made to each unit on the job. These main supply lines must be functional and capable of operating all units simultaneously.
- Air filters are in place.

ROOF CURB INSTALLATION CHECK

Inspect the roof curb for correct installation. The unit and curb assembly should be level. Inspect the flashing of the roof mounting curb to the roof, especially at the corners, for good workmanship. Also check for leaks around gaskets. Note any deficiencies in a separate report and forward to the contractor.

OBSTRUCTIONS, FAN CLEARANCE AND WIRING

Remove any extraneous construction and shipping materials that may be found during this procedure. Rotate all fans manually to check for proper clearances and that they rotate freely. Check for bolts and screws that may have jarred loose during shipment to the job site. Re-tighten if necessary. Re-tighten all electrical connections.

FIELD DUCT CONNECTIONS

Verify that all duct connections are tight and that there is no air bypass between supply and return.

FILTER SECTION CHECK

Remove filter section access panels and check that filters are properly installed. Note airflow arrows on filter frames.

PRE-STARTUP PRECAUTIONS

It is important for your safety that the unit has been properly grounded during installation. Check ground lug connection in main control box for tightness prior to closing circuit breaker or disconnect switch. Verify that supply voltage on line side of disconnect agrees with voltage on unit identification plate and is within the utilization voltage range as indicated in Appendix B Electrical Data.

System Voltage - The nominal voltage value assigned to a circuit or system for the purpose of designating its voltage class.

Nameplate Voltage - The voltage assigned to a piece of equipment for the purpose of designating its voltage class and for the purpose of defining the minimum and maximum voltage at which the equipment will operate.

Utilization Voltage - The voltage of the line terminals of the equipment at which the equipment must give fully satisfactory performance. Once it is established that supply voltage will be maintained within the utilization range under all system conditions, check and calculate if an unbalanced condition exists between phases. Calculate percent voltage unbalance as follows.

THREE PHASE MODELS ONLY

$$3) \text{ PERCENT VOLTAGE UNBALANCE} = 100 \times \frac{2) \text{ MAXIMUM VOLTAGE DEVIATIONS FROM AVERAGE VOLTAGE}}{1) \text{ AVERAGE VOLTAGE}}$$

HOW TO USE THE FORMULA:

EXAMPLE: Line to Neutral Voltage of 220, 216, and 213

1) Average Voltage = $220+216+213=649 / 3 = 216$

2) Maximum Voltage Deviations from Average Voltage = $220 - 216 = 4$

3) Percent Voltage Unbalance = $100 \times \frac{4}{216} = \frac{400}{216} = 1.8\%$

Percent voltage unbalance MUST NOT exceed 2%.

CONTROL VOLTAGE CHECK

Close the disconnect switch to energize control transformer. Check primary and secondary (24V) of control transformer.

AIR FLOW ADJUSTMENTS

NOTE: FOR 2 SPEED MODELS, AIRFLOW ADJUSTMENTS MUST BE MADE ON HIGH SPEED, I.E., 2ND STAGE COOLING OR IN HEAT MODE.

The drive on the supply fan is typically set in the middle of the RPM range. The drive motor sheave pitch diameter is field adjustable for the required airflow. Upon completion of the air flow balancing, we recommend replacing the variable pitched motor sheave with a properly-sized fixed sheave. A matching fixed sheave will provide longer belt and bearing life and vibration free operation. Initially, it is best to have a variable pitched motor sheave for the purpose of airflow balancing, but once the balance has been achieved, fixed sheaves maintain alignment and minimize vibration more effectively. Refer to the following "Drive Adjustments" section.

When the final adjustments are complete, the current draw of the motor should be checked and compared to the full load current rating of the motor. The amperage must not exceed the service factor stamped on the motor nameplate.

If an economizer is installed, check the unit operating balance with the economizer at full outside air and at minimum outside air. Upon completion of the air flow balancing, we recommend replacing the variable pitched motor sheave with a properly-sized fixed sheave. A matching fixed sheave will provide longer belt and bearing life and vibration free operation. Initially, it is best to have a variable pitched motor sheave for the purpose of airflow balancing, but once the balance has been achieved, fixed sheaves maintain alignment and minimize vibration more effectively.

NOTE: NEVER RUN HIGH STAGE CFM BELOW 300 CFM PER TON, EVAPORATOR FREEZING OR POOR UNIT PERFORMANCE IS POSSIBLE.

EVAPORATOR FAN ROTATION CHECK

Check that fan rotates clockwise when viewed from the drive side of unit and in accordance with rotation arrow shown on blower housing. If it does not, reverse any two incoming power cables at Single Point Power Block. In this case, repeat bearing check.

Do not attempt to change load side wiring. Internal wiring assures all motors and compressors will rotate in correct direction once evaporator fan motor rotation check has been made.

ELECTRICAL INPUT CHECK

Make preliminary check of evaporator fan ampere draw and verify that motor nameplate amps are not exceeded. A final check of amp draw should be made upon completion of air balancing of the duct system.

SET EVAPORATOR FAN RPM

Actual RPM's must be set and verified with a tachometer or strobe light. Refer to Appendix A for basic unit fan RPM. Refer also to "Airflow" section of this manual. With disconnect switch open, disconnect thermostat wires from terminals Y and W. This will prevent heating and mechanical cooling from coming on. Place a jumper wire across terminals R and G at TB1 terminal block. Close disconnect switch; evaporator fan motor will operate so RPM can be checked.

BELT DRIVE MODELS ONLY

Refer to "Motor Sheave Adjustments" section.

BEARING CHECK

Prior to energizing any fans, check and make sure that all setscrews are tight so that bearings are properly secured to shafts.

TENSION AND ALIGNMENT ADJUSTMENT

Correct belt tension is very important to the life of your belt. Too loose a belt will shorten its life; too tight, premature motor and bearing failure will occur. Check your belt drive for adequate "run-in" belt tension by measuring the force required to deflect the belt at the midpoint of the span length. Belt tension force can be measured using a belt tension gauge, available through most belt drive manufacturers.

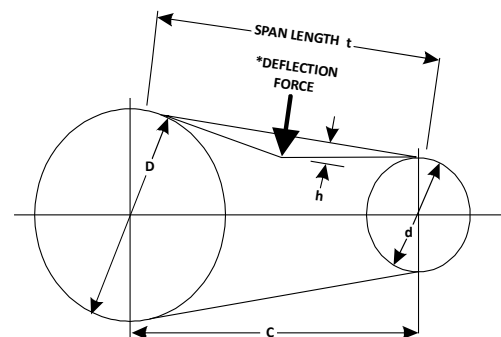

***APPLY FORCE TO THE CENTER OF THE SPAN.**

- t = Span length, inches
- C = Center distance, inches
- D = Larger sheave diameter, inches
- d = Smaller sheave diameter, inches
- h = Deflection height, inches

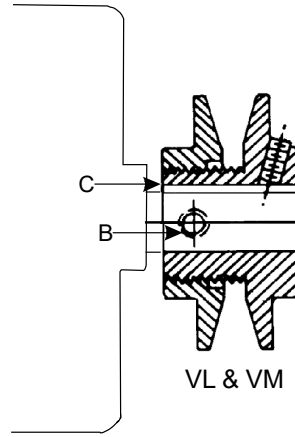

DRIVE BELT TENSION ADJUSTMENT

MODEL	TYPE		SHEAVE DIAMETER (d) (in)	DEFLECTION FORCE (lbs)		DEFLECTION (in)
	BELT	DRIVE		Used	New	
DBH/DBC090*V	A	Standard	2.6 to 3.6	4.5+/- .5	5.5+/- .5	1/4+/- 1/16
DBH/DBC090*S			3.0 to 4.0	4.5+/- .5	5.5+/- .5	1/4+/- 1/16
DBH/DBC102*V			2.6 to 3.6	4.5+/- .5	5.5+/- .5	1/4+/- 1/16
DBH/DBC102*S			3.0 to 4.0	4.5+/- .5	5.5+/- .5	1/4+/- 1/16
DBH/DBC120*V			2.6 to 3.6	4.5+/- .5	5.5+/- .5	1/4+/- 1/16
DBH/DBC120*S			3.0 to 4.0	4.5+/- .5	5.5+/- .5	1/4+/- 1/16
DBC150*V			3.0 to 4.0	4.5+/- .5	5.5+/- .5	1/4+/- 1/16
DBC150*S			4.2 to 5.2	4.5+/- .5	5.5+/- .5	1/4+/- 1/16

RECOMMENDED POUNDS OF FORCE PER BELT

When new V-belts are installed on a drive the initial tension will drop rapidly during the first few hours. Check tension frequently during the first 24 hours of operation. Subsequent re-tensioning should fall between the minimum and maximum force. To determine the deflection distance from the normal position, use a straightedge or stretch a cord from sheave to sheave to use as a reference line. On multiple belt drives, an adjacent undeflected belt can be used as a reference.

MOTOR SHEAVE ADJUSTMENTS

VL, VM & 2VP VARIABLE PITCH KEY TYPE MOTOR SHEAVES

The driving and driven sheaves should be in alignment with each other and the shafts parallel.

VL & VM SHEAVES ADJUSTMENT

1. Loosen set screw "B" using a 5/32" Allen key.
2. Making half or full turns from closed position, adjust sheave pitch diameter for desired speed. **DO NOT OPEN MORE THAN SIX FULL TURNS.**
3. Tighten set screw "B" securely over flat.
4. Carefully put on belts and adjust belt tension. **DO NOT FORCE BELTS OVER GROOVES.**
5. Ensure all keys are in place and the set screws tight before starting drive. Recheck set screws and belt tension after 24 hours service.

NOTE: FUTURE ADJUSTMENTS SHOULD BE MADE BY LOOSENING THE BELT TENSION AND INCREASING OR DECREASING THE PITCH DIAMETER OF THE SHEAVE BY HALF OR FULL TURNS AS REQUIRED. READJUST BELT TENSION BEFORE STARTING DRIVE.

NOTE: DO NOT OPERATE SHEAVE WITH FLANGE PROJECTING BEYOND THE HUB END.

ELECTRICAL INPUT CHECK

Make preliminary check of evaporator fan ampere draw and verify that motor nameplate amps are not exceeded. A final check of amp draw should be made upon completion of air balancing of the duct system (see Appendix B).

REFRIGERATION SYSTEM CHECKS

Heat pump units are equipped with thermal expansion valves.

Ensure the hold-down bolts on the compressor are secure and have not vibrated loose during shipment. Check that the vibration grommets have been installed and visually check all piping for damage and leaks and repair if necessary. The entire system has been factory charged and tested, making it unnecessary to field charge. Factory refrigerant charge is shown on the unit's nameplate. To confirm charge levels or, if a leak occurs and charge needs to be added to the system, it is recommended to evacuate the system and recharge refrigerant to the unit's nameplate specifications. This unit has been rated in the cooling mode at the AHRI rated conditions of: indoor (80°F db/67°F wb) and outdoor (95°F db). While operating at this condition, the superheat (measured at the suction service port located near the compressor) or the subcool (measured at the outdoor liquid line port) should be within the range given in the following table.

Unit	Subcool (°F)	Superheat (°F)
DBC090*	N/A	11 to 15
DBC102*		10 to 14
DBC120*		10 to 14
DBC150*		11 to 17
DBH090*	3 to 7	10 to 15
DBH102*	13 to 17	
DBH120*	9 to 13	
DBH150*	10 to 14	



AIR CONDITIONING START-UP PROCEDURE AND CHECKLIST

Begin with power turned off at all disconnects.

1. Turn thermostat system switch to "Cool," and fan switch to "Auto" and turn temperature setting as high as it will go.
2. Inspect all registers and set them to the normal open position.
3. Turn on the electrical supply at the disconnect.
4. Turn the fan switch to the "ON" position. The blower should operate after a 7 second delay.
5. Turn the fan switch to "Auto" position. The blower should stop after a 60 second delay.
6. Slowly lower the cooling temperature until first stage COOL (LOW COOL) starts. The blower, both fans, and first stage compressor should now be operating. Allow the unit to run 10 minutes, make sure cool air is being supplied by the unit.
7. Lower the cooling temperature further until second stage COOL (HIGH COOL) starts. The blower, both fans, and both compressors should now be operating. Allow the unit to run 10 minutes, make sure cool air is being supplied by the unit.
8. Turn the temperature setting to the highest position, stopping the unit. The indoor blower will continue to run for 60 seconds.
9. Turn the thermostat system switch to "OFF" and disconnect all power when servicing the unit.

heated air.

4. If the outdoor ambient is above 80°F, the unit may trip on its high pressure cut out when on heating. The compressor should stop. The heating cycle must be thoroughly checked, so postpone the test to another day when conditions are more suitable but-DO NOT FAIL TO TEST.
If the outdoor ambient is low and the unit operates properly on the heating cycle, you may check the pressure cutout operation by blocking off the indoor return air until the unit trips.
5. If unit operates properly in the heating cycle, raise the temperature setting until the heating second stage makes contact. Supplemental resistance heat, if installed should now come on. Make sure it operates properly.
NOTE: If outdoor thermostats are installed the outdoor ambient must be below the set point of these thermostats for the heaters to operate. It may be necessary to jumper these thermostats to check heater operation if outdoor ambient is mild.
6. For thermostats with emergency heat switch, return to step 11. The emergency heat switch is located at the bottom of the thermostat. Move the switch to emergency heat. The heat pump will stop, the blower will continue to run, all heaters will come on and the thermostat emergency heat light will come on.
7. If checking the unit in the wintertime, when the outdoor coil is cold enough to actuate the defrost control, observe at least one defrost cycle to make sure the unit defrosts completely.

	WARNING
HIGH VOLTAGE! DISCONNECT ALL POWER BEFORE SERVICING OR INSTALLING THIS UNIT. MULTIPLE POWER SOURCES MAY BE PRESENT. FAILURE TO DO SO MAY CAUSE PROPERTY DAMAGE, PERSONAL INJURY OR DEATH.	
	

REFRIGERATION SEQUENCE CHECK

With the disconnect switch open, remove the field connected thermostat wire from terminal R on TB1 terminal block. Place a jumper across terminals R and G, and across R and Y on TB1 terminal block. Close the disconnect switch. The following operational sequence should be observed:

1. Current through primary winding of transformer TRANS1 energizes the 24-volt control circuit.
2. To simulate a mechanical call for cooling from the wall thermostat, place a jumper across terminals R and Y1 of terminal block TB1.
3. **UNIT WITH ECONOMIZER OPTION:** The compressor circuit is interlocked through terminals 3 and 4 of the economizer module. If the outdoor air enthalpy (temperature and humidity) is not suitable for cooling, the economizer terminals will be closed permitting compressor to be energized.
4. The belt drive blower contractor closes its contacts L1, L2 and L3 to T1, T2 and T3 to provide power to the supply fan motor.
5. Check supply fan rotation. If the supply fan is rotating in the wrong direction, disconnect and lock off Single Point Power Block. Do not attempt to change load side wiring. Internal wiring is set at the factory to assure that the supply fan and compressors all rotate in the proper direction. Verification of correct supply fan rotation at initial startup will also indicate correct compressor rotation. Reconnect power and check for

HEAT PUMP START-UP PROCEDURE

1. Check the cooling mode for the heat pump in the same manner as above. The reversing valve is energized when the thermostat is placed in the cooling position. A clicking sound should be noticeable from the reversing valve. By lowering the temperature setting to call for cooling, the contractor is energized. The compressor, blower and fan should then be running. After the cooling mode is checked out, turn the thermostat system switch to "OFF".
2. Turn the thermostat system switch to "HEAT" and fan switch to "AUTO".
3. Slowly raise the heating temperature setting. When the heating first stage makes contact, stop raising the temperature setting. The compressor, blower and fan should now be running with the reversing valve in the de-energized (heating) position. After giving the unit time to settle out, make sure the unit is supplying

proper operation.

6. Compressor contractor closes its contacts L1, L2 and L3 to T1, T2 and T3 to provide power to the compressor motor COMP 1; COMP 2, if conditions are correct. In addition, contractor C1 closes its contact L3 to T3, energizing the condenser fan motor.

 WARNING
BURN HAZARD! DO NOT TOUCH! DISCHARGE LINE MAY BE HOT!

7. Check that each compressor is operating correctly. The scroll compressors in these units MUST operate in the proper rotation. To ensure the compressors are operating in the correct direction, check the compressor discharge line pressure or temperature after each compressor is started. The discharge pressure and discharge line temperature should increase. If this does not occur and the compressor is producing an exceptional amount of noise, perform the following checks.
 - Ensure all compressors and the supply fan motor are operating in the proper direction. If a single motor is operating backwards, check the power wiring for that motor and correct any leads that have been interchanged at the contractor or at the motor.
 - If all of the motors are operating backward, disconnect the unit power supply and lock it in the "OFF" position. Switch two leads of the power supply at the unit Single Point Power Block. Reconnect power and check for compressor and supply fan motor operation.
8. With all safety devices closed, the system will continue cooling operation until the thermostat is satisfied.
9. Disconnecting the jumper wire between R and Y1 and Y2 and between R and G on TB1 terminal block will simulate a satisfied thermostat. The compressors will cycle off and IIC (pin 12) will initiate its time delay cycle. The compressor and the supply fan will cycle off.
10. After a time delay of approximately 3 minutes, the compressor control circuits will be ready to respond to a subsequent call for cooling from the wall thermostat.
11. Open disconnect switch. Reconnect the field thermostat wire at terminal R on terminal block TB1.

START-UP PROCEDURE AND CHECKLIST FOR 2 SPEED MODELS:



Models with V or S in the 8th position of the model number.

For 2 speed models, the indoor blower will operate on low speed when in "Fan Only" mode or while in first stage "Cooling" mode. Unit will operate on high speed in "Heating" mode and while in second stage "Cooling"

mode.

The same start-up procedure should be followed as in Start-Up Procedure and Checklist with the understanding that in Step 6 the indoor blower will run at low speed and in Step 7 the indoor blower will operate at high speed.

NOTE: WHILE IN THE COOLING MODE, TO PREVENT FROST FROM FORMING ON THE EVAPORATOR WHILE THE UNIT IS OPERATING IN OUTDOOR TEMPERATURES OF 65°F OR LOWER, IT IS RECOMMENDED THAT A LOW AMBIENT KIT (LAKT.*) IS USED. THIS IS STRONGLY RECOMMENDED FOR 2 SPEED MODELS DUE TO THE LOWER AIRFLOW WHILE IN THE FIRST STAGE COOLING. TO FURTHER PROTECT THE COMPRESSOR FROM DAMAGE DURING LOW AMBIENT CONDITIONS, A FREEZESTAT KIT (FSK01) CAN BE ADDED THAT TURNS THE COMPRESSOR OFF WHEN THE EVAPORATOR TEMPERATURE DROPS TOO LOW.**

 WARNING	
HIGH VOLTAGE! DISCONNECT ALL POWER BEFORE SERVICING OR INSTALLING THIS UNIT. MULTIPLE POWER SOURCES MAY BE PRESENT. FAILURE TO DO SO MAY CAUSE PROPERTY DAMAGE, PERSONAL INJURY OR DEATH.	

REFRIGERATION PERFORMANCE CHECK

Check that compressor RLA corresponds to values shown in Appendix B. RLA draw can be much lower than values listed at low load conditions and low ambient condensing temperatures. Values in Appendix B can slightly exceed at high load conditions and high ambient condensing temperatures.

FINAL SYSTEM CHECKS

1. Check to see if all supply and return air grilles are adjusted and the air distribution system is balanced for the best compromise between heating and cooling.
2. Check for air leaks in the ductwork. See Sections on Air Flow Adjustments.
3. Make sure the unit is free of "rattles", and the tubing in the unit is free from excessive vibration. Also make sure tubes or lines are not rubbing against each other or sheet metal surfaces or edges. If so, correct the trouble.
4. Set the thermostat at the appropriate setting for cooling and heating or automatic changeover for normal use.
5. Be sure the Owner is instructed on the unit operation, filter, servicing, correct thermostat operation, etc.

HEAT PUMP OPERATION

COOLING CYCLE

When the heat pump is in the cooling cycle, it operates exactly as a Summer Air Conditioner unit. In this mode, all the charts and data for service that apply to summer air conditioning apply to the heat pump. Most apply on the heating cycle except that “condenser” becomes “evaporator”, “evaporator” becomes “condenser”, “cooling” becomes “heating”.

HEATING CYCLE

The heat pump operates in the heating cycle by redirecting refrigerant flow through the refrigerant circuit external to the compressor. This is accomplished with through the reversing valve. Hot discharge vapor from the compressor is directed to the indoor coil (evaporator on the cooling cycle) where the heat is removed, and the vapor condenses to liquid. It then goes through the expansion device to the outdoor coil (condenser on the cooling cycle) where the liquid is evaporated, and the vapor goes to the compressor.

When the solenoid valve coil is operated either from heating to cooling or vice versa, the piston in the reversing valve to the low pressure (high pressure) reverse positions in the reversing valve.

The following figures show a schematic of a heat pump on the cooling cycle and the heating cycle. In addition to a reversing valve, a heat pump is equipped with an expansion device and check valve for the indoor coil, and similar equipment for the outdoor coil. It is also provided with a defrost control system.

The expansion devices are flowrator distributors and perform the same function on the heating cycle as on the cooling cycle. The flowrator distributors also act as check valves to allow for the reverse of refrigerant flow.

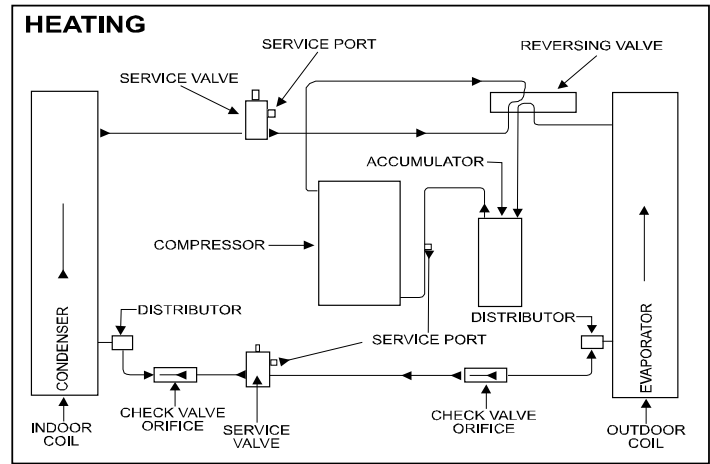

When the heat pump is on the heating cycle, the outdoor coil is functioning as an evaporator. The temperature of the refrigerant in the outdoor coil must be below the temperature of the outdoor air in order to extract heat from the air. Thus, the greater the difference in the outdoor temperature and the outdoor coil temperature, the greater the heating capacity of the heat pump. This phenomenon is a characteristic of a heat pump. It is a good practice to provide supplementary heat for all heat pump installations in areas where the temperature drops below 45° F. It is also a good practice to provide sufficient supplementary heat to handle the entire heating requirement should there be a component failure of the heat pump, such as a compressor, or refrigerant leak, etc.

Since the temperature of the refrigerant in the outdoor coil on the heating cycle is generally below freezing point, frost forms on the surfaces of the outdoor coil under certain weather conditions of temperature and relative humidity. Therefore, it is necessary to reverse the flow of the refrigerant to provide hot gas in the outdoor coil to melt the frost accumulation. This is accomplished by reversing the heat pump to the cooling cycle. At the same time, the outdoor fan stops to hasten the temperature rise of the outdoor coil and lessen the time required for defrosting. The indoor blower continues to run and the supplementary heaters are energized.

DEFROST CONTROL

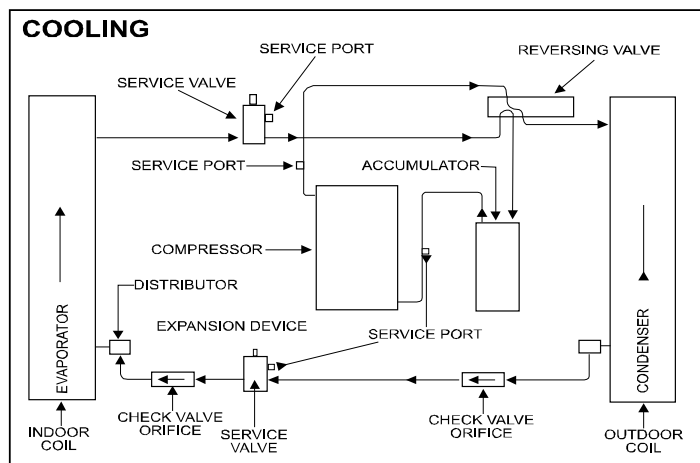

Note: DBH models have one stage of mechanical heating. The defrost accumulation period will start when either first or second stage defrost thermostat closes. Defrost termination occurs when both thermostats open or the 10 minute cycle has completed.



During operation the power to the circuit board is controlled by a temperature sensor, which is clamped to a feeder tube entering the outdoor coil. Defrost timing periods of 30,60 and 90 minutes may be selected by connecting the circuit board jumper to 30, 60 and 90 respectively. Accumulation of time for the timing period selected starts when the sensor closes (approximately 31° F), and when the wall thermostat calls for heat. At the end of the timing period, the unit's defrost cycle will be initiated provided the sensor remains closed. When the sensor opens (approximately 75° F), the defrost cycle is terminated and the timing period is reset. If the defrost cycle is not terminated due to the sensor temperature, a ten minute override interrupts the unit's defrost period.

MAINTENANCE

	WARNING
<p>ELECTRICAL SHOCK, FIRE OR EXPLOSION HAZARD FAILURE TO FOLLOW SAFETY WARNINGS EXACTLY COULD RESULT IN DANGEROUS OPERATION, SERIOUS INJURY, DEATH OR PROPERTY DAMAGE. IMPROPER SERVICING COULD RESULT IN DANGEROUS OPERATION, SERIOUS INJURY, DEATH OR PROPERTY DAMAGE.</p> <ul style="list-style-type: none"> • BEFORE SERVICING, DISCONNECT ALL ELECTRICAL POWER TO FURNACE. • WHEN SERVICING CONTROLS, LABEL ALL WIRES PRIOR TO DISCONNECTING. RECONNECT WIRES CORRECTLY. • VERIFY PROPER OPERATION AFTER SERVICING. 	

	WARNING
<p>HIGH VOLTAGE! DISCONNECT ALL POWER BEFORE SERVICING OR INSTALLING THIS UNIT. MULTIPLE POWER SOURCES MAY BE PRESENT. FAILURE TO DO SO MAY CAUSE PROPERTY DAMAGE, PERSONAL INJURY OR DEATH.</p>	

	WARNING
<p>TO PREVENT PERSONAL INJURY OR DEATH DUE TO IMPROPER INSTALLATION, ADJUSTMENT, ALTERATION, SERVICE OR MAINTENANCE, REFER TO THIS MANUAL. FOR ADDITIONAL ASSISTANCE OR INFORMATION, CONSULT A QUALIFIED INSTALLER, SERVICER AGENCY OR THE GAS SUPPLIER.</p>	

	CAUTION
<p>SHEET METAL PARTS, SCREWS, CLIPS AND SIMILAR ITEMS INHERENTLY HAVE SHARP EDGES, AND IT IS NECESSARY THAT THE INSTALLER AND SERVICE PERSONNEL EXERCISE CAUTION.</p>	

Preventive maintenance is the best way to avoid unnecessary expense and inconvenience. Have this system inspected at regular intervals by qualified service personnel, at least twice a year. Routine maintenance should cover the following items:

1. Tighten all belts, set screws, and wire connections.
2. Clean evaporator and condenser coils mechanically or with cold water, if necessary. Usually any fouling is only matted on the entering air face of the coil and can be removed by brushing.
3. Lubricate motor bearings.
4. Align or replace belts as needed.
5. Replace filters as needed (see Filters section).
6. Check for blockage of condensate drain.
7. Check power and control voltages.
8. Check running amperage.
9. Check operating temperatures and pressures.
10. Check and adjust temperature and pressure controls.
11. Check and adjust damper linkages.
12. Check operation of all safety controls.
13. Check condenser fans and tighten set screws.

FILTERS

	CAUTION
<p>TO PREVENT PROPERTY DAMAGE DUE TO FIRE AND LOSS OF EQUIPMENT EFFICIENCY OR EQUIPMENT DAMAGE DUE TO DUST AND LINT BUILD UP ON INTERNAL PARTS, NEVER OPERATE UNIT WITHOUT AN AIR FILTER INSTALLED IN THE RETURN AIR SYSTEM.</p>	

Every application may require a different frequency of replacement of dirty filters. Filters must be replaced at least every three (3) months during operating seasons.

Dirty filters are the most common cause of inadequate heating or cooling performance. Filter inspection should be made at least every two months; more often if necessary because of local conditions and usage.

Dirty throwaway filters should be discarded and replaced with a new, clean filter.

Disposable return air filters are supplied with this unit. See the unit Specification Sheet or Technical Manual for the correct size and part number. To remove the filters, remove the filter access panel on return side of the unit.

CABINET FINISH MAINTENANCE

Use a fine grade automotive wax on the cabinet finish to maintain the finish's original high luster. This is especially important in installations with extended periods of direct sunlight.

CLEAN OUTSIDE COIL (QUALIFIED SERVICER ONLY)

The coil with the outside air flowing over it should be inspected annually and cleaned as frequently as necessary to keep the finned areas free of lint, hair and debris.

CONDENSER AND INDUCED DRAFT MOTORS

Bearings on the condenser fan motors and the combustion fan motor are permanently lubricated. No additional oiling is required.

LUBRICATION

The fan shaft bearings, the supply fan motors, the condenser fan motors and compressors are permanently lubricated.

FUNCTIONAL PARTS

Refer to the unit Parts Catalog for a list of functional parts. Parts are available from your distributor.

TROUBLESHOOTING

THE FOLLOWING INFORMATION IS FOR USE BY QUALIFIED SERVICE AGENCY ONLY: OTHERS SHOULD NOT ATTEMPT TO SERVICE THIS EQUIPMENT.

Common Causes of Unsatisfactory Operation of Heat Pump on the Heating Cycle.

INADEQUATE AIR VOLUME THROUGH INDOOR COIL

When a heat pump is in the heating cycle, the indoor coil is functioning as a condenser. The return air filter must always be clean, and sufficient air volume must pass through the indoor coil to prevent excessive discharge pressure, and high pressure cut out.

OUTSIDE AIR INTO RETURN DUCT

Do not introduce cold outside air into the return duct of a heat pump installation. For units with 2-speed motors, do not allow air entering the indoor coil to drop below 65°F. Air below this temperature will cause low discharge pressure, thus low suction pressure, and excessive defrost cycling resulting in low heating output. It may also cause false defrosting.

UNDERCHARGE

An undercharged heat pump on the heating cycle will cause low discharge pressure resulting in low suction pressure and frost accumulation on the outdoor coil.

POOR "TERMINATING" SENSOR CONTACT

The unit's defrost terminating sensor must make good thermal contact with the outdoor coil tubing. Poor contact may not terminate the unit's defrost cycle quickly enough to prevent the unit from cutting out on high discharge pressure.

MALFUNCTIONING REVERSING VALVE - THIS MAY BE DUE TO:

- 1. Solenoid not energized** - In order to determine if the solenoid is energized, touch the nut that holds the solenoid cover in place with a screwdriver. If the nut magnetically holds the screwdriver, the solenoid is energized and the unit is in the cooling cycle.
- 2. No voltage at unit's solenoid** - Check unit voltage. If no voltage, check wiring circuit.
- 3. Valve will not shift:**
 - a. Undercharged** - check for leaks;
 - b. Valve Body Damaged** - Replace valve;
 - c. Unit Properly Charged** - If it is on the heating cycle, raise the discharge pressure by restricting airflow through the indoor coil. If the valve does not shift, tap it lightly on both ends with a screwdriver handle. **DO NOT TAP THE VALVE BODY.** If the unit is on the cooling cycle, raise the discharge pressure by restricting airflow through the outdoor coil. If the valve does not shift after the above attempts, cut the unit off and wait until the discharge and suction pressure equalize, and repeat above steps. If the valve does not shift, replace it.

APPENDIX A BLOWER PERFORMANCE DATA

7.5 TON AC

DBC090°V STANDARD STATIC HORIZONTAL

ESP, In H ₂ O	TURNS OPEN																	
	0			1			2			3			4			5		
	CFM	RPM	BHP	CFM	RPM	BHP	CFM	RPM	BHP	CFM	RPM	BHP	CFM	RPM	BHP	CFM	RPM	BHP
0.1										3636	652	1.11	3403	613	0.95	3165	600	0.74
0.2										3532	652	1.06	3193	613	0.87	2907	600	0.66
0.3							3654	692	1.17	3373	652	0.99	2983	613	0.78	2650	600	0.58
0.4				3748	732	1.24	3477	692	1.09	3161	652	0.90	2773	613	0.71	2392	600	0.51
0.5				3563	732	1.16	3251	692	0.99	2893	652	0.80	2563	613	0.63			
0.6	3678	770	1.37	3345	732	1.06	2977	692	0.88	2572	652	0.68	2353	613	0.57			
0.7	3465	770	1.26	3096	732	0.95	2656	692	0.76									
0.8	3228	770	1.14	2815	732	0.84	2287	692	0.63									

DBC090°S HIGH STATIC HORIZONTAL¹

ESP, In H ₂ O	TURNS OPEN																	
	0			1			2			3			4			5		
	CFM	RPM	BHP	CFM	RPM	BHP	CFM	RPM	BHP	CFM	RPM	BHP	CFM	RPM	BHP	CFM	RPM	BHP
0.8																3444	838	1.26
0.9													3678	889	1.80	3228	840	1.16
1.0													3434	891	1.65	2984	842	1.04
1.1										3702	943	1.86	3162	895	1.49	2712	845	0.92
1.2										3467	944	1.71	2862	899	1.32	2412	849	0.80
1.3							3773	993	2.10	3216	945	1.56	2534	905	1.15			
1.4							3542	996	1.94	2950	946	1.41						
1.5				3737	1050	2.14	3297	1000	1.77	2668	947	1.26						
1.6				3444	1053	1.93	3039	1003	1.61	2371	947	1.11						
1.7				3125	1050	1.72	2767	1000	1.44									
1.8	3732	1096	2.32	2781	1053	1.51	2481	1003	1.28									

¹To operate below 0.8" H₂O external static pressure, motor and blower sheave must be changed to VL40 and AK84H respectively, or equivalents

DBC090°V STANDARD STATIC DOWNSHOT

ESP, In H ₂ O	TURNS OPEN																	
	0			1			2			3			4			5		
	CFM	RPM	BHP	CFM	RPM	BHP	CFM	RPM	BHP	CFM	RPM	BHP	CFM	RPM	BHP	CFM	RPM	BHP
0.1																3681	600	0.93
0.2													3708	613	0.94	3349	600	0.81
0.3										3773	652	1.17	3391	613	0.83	2986	600	0.69
0.4										3455	652	1.02	3037	613	0.71	2593	600	0.57
0.5							3574	692	1.13	3116	652	0.88	2645	613	0.59			
0.6				3715	732	1.23	3236	692	0.98	2757	652	0.74						
0.7				3403	732	1.08	2867	692	0.83	2376	652	0.61						
0.8	3550	770	1.30	3068	732	0.94	2467	692	0.69									

DBC090°S HIGH STATIC DOWNSHOT¹

ESP, In H ₂ O	TURNS OPEN																	
	0			1			2			3			4			5		
	CFM	RPM	BHP	CFM	RPM	BHP	CFM	RPM	BHP	CFM	RPM	BHP	CFM	RPM	BHP	CFM	RPM	BHP
0.8																3676	1077	1.38
0.9																3391	1078	1.23
1.0													3708	1078	1.82	3017	1079	1.05
1.1													3347	1079	1.59	2556	1080	0.85
1.2										3586	1079	1.78	2908	1080	1.34			
1.3										3287	1080	1.60	2391	1081	1.07			
1.4							3539	1080	1.93	2973	1081	1.42						
1.5							3175	1081	1.69	2645	1082	1.24						
1.6				3690	1081	2.09	2777	1082	1.44	2302	1083	1.07						
1.7				3426	1082	1.90	2347	1083	1.20									
1.8	3745	1082	2.19	3152	1083	1.72												

¹To operate below 0.8" H₂O external static pressure, motor and blower sheave must be changed to VL40 and AK84H respectively, or equivalents

APPENDIX A BLOWER PERFORMANCE DATA

8.5 TON AC

DBC102*V STANDARD STATIC HORIZONTAL

ESP, In H ₂ O	TURNS OPEN																	
	0			1			2			3			4			5		
	CFM	RPM	BHP	CFM	RPM	BHP	CFM	RPM	BHP	CFM	RPM	BHP	CFM	RPM	BHP	CFM	RPM	BHP
0.1				4111	732	1.42	3866	692	1.27	3636	652	1.11	3403	613	0.95	3165	600	0.74
0.2				4022	732	1.38	3784	692	1.23	3532	652	1.06	3193	613	0.87	2907	600	0.66
0.3	4176	770	1.66	3901	732	1.32	3654	692	1.17	3373	652	0.99	2983	613	0.78	2650	600	0.58
0.4	4033	770	1.57	3748	732	1.24	3477	692	1.09	3161	652	0.90	2773	613	0.71			
0.5	3867	770	1.48	3563	732	1.16	3251	692	0.99	2893	652	0.80	2563	613	0.63			
0.6	3678	770	1.37	3345	732	1.06	2977	692	0.88	2572	652	0.68						
0.7	3465	770	1.26	3096	732	0.95	2656	692	0.76									
0.8	3228	770	1.14	2815	732	0.84												

DBC102*S HIGH STATIC HORIZONTAL¹

ESP, In H ₂ O	TURNS OPEN																	
	0			1			2			3			4			5		
	CFM	RPM	BHP	CFM	RPM	BHP	CFM	RPM	BHP	CFM	RPM	BHP	CFM	RPM	BHP	CFM	RPM	BHP
0.8													3894	888	1.94	3444	838	1.26
0.9										4126	940	2.15	3678	889	1.80	3228	840	1.16
1.0										3922	942	2.01	3434	891	1.65	2984	842	1.04
1.1							4194	987	2.42	3702	943	1.86	3162	895	1.49	2712	845	0.92
1.2							3990	990	2.26	3467	944	1.71	2862	899	1.32			
1.3				4245	1044	2.52	3773	993	2.10	3216	945	1.56	2534	905	1.15			
1.4				4004	1047	2.33	3542	996	1.94	2950	946	1.41						
1.5				3737	1050	2.14	3297	1000	1.77	2668	947	1.26						
1.6	4139	1096	2.66	3444	1053	1.93	3039	1003	1.61									
1.7	3939	1093	2.49	3125	1050	1.72	2767	1000	1.44									
1.8	3732	1096	2.32	2781	1053	1.51												

¹To operate below 0.8" H₂O external static pressure, motor and blower sheave must be changed to VL40 and AK84H respectively, or equivalents

DBC102*V STANDARD STATIC DOWNSHOT¹

ESP, In H ₂ O	TURNS OPEN																	
	0			1			2			3			4			5		
	CFM	RPM	BHP	CFM	RPM	BHP	CFM	RPM	BHP	CFM	RPM	BHP	CFM	RPM	BHP	CFM	RPM	BHP
0.1													3988	613	1.05	3681	600	0.93
0.2										4070	652	1.31	3708	613	0.94	3349	600	0.81
0.3							4160	692	1.42	3773	652	1.17	3391	613	0.83	2986	600	0.69
0.4				4269	732	1.50	3882	692	1.28	3455	652	1.02	3037	613	0.71	2593	600	0.57
0.5				4004	732	1.37	3574	692	1.13	3116	652	0.88	2645	613	0.59			
0.6	4106	770	1.61	3715	732	1.23	3236	692	0.98	2757	652	0.74						
0.7	3836	770	1.46	3403	732	1.08	2867	692	0.83									
0.8	3550	770	1.30	3068	732	0.94												

DBC102*S HIGH STATIC DOWNSHOT

ESP, In H ₂ O	TURNS OPEN																	
	0			1			2			3			4			5		
	CFM	RPM	BHP	CFM	RPM	BHP	CFM	RPM	BHP	CFM	RPM	BHP	CFM	RPM	BHP	CFM	RPM	BHP
0.8													4197	1076	2.15	3676	1077	1.38
0.9													3991	1077	2.00	3391	1078	1.23
1.0										4141	1077	2.15	3708	1078	1.82	3017	1079	1.05
1.1										3871	1078	1.97	3347	1079	1.59	2556	1080	0.85
1.2							4170	1078	2.40	3586	1079	1.78	2908	1080	1.34			
1.3							3871	1079	2.17	3287	1080	1.60						
1.4				4193	1079	2.47	3539	1080	1.93	2973	1081	1.42						
1.5				3946	1080	2.28	3175	1081	1.69	2645	1082	1.24						
1.6	4235	1080	2.56	3690	1081	2.09	2777	1082	1.44									
1.7	3995	1081	2.37	3426	1082	1.90												
1.8	3745	1082	2.19	3152	1083	1.72												

¹To operate below 0.8" H₂O external static pressure, motor and blower sheave must be changed to VL40 and AK84H respectively, or equivalents

APPENDIX A BLOWER PERFORMANCE DATA

10 TON AC

DBC120*V STANDARD STATIC HORIZONTAL

ESP, In H ₂ O	TURNS OPEN																	
	0			1			2			3			4			5		
	CFM	RPM	BHP	CFM	RPM	BHP	CFM	RPM	BHP	CFM	RPM	BHP	CFM	RPM	BHP	CFM	RPM	BHP
0.1							4575	790	1.72	4308	743	1.54	4035	697	1.20	3740	651	1.05
0.2							4454	790	1.65	4167	743	1.46	3860	697	1.13	3553	651	0.98
0.3							4300	790	1.57	3987	743	1.37	3645	697	1.04	3301	651	0.88
0.4							4114	790	1.47	3767	743	1.26	3389	697	0.95	2985	651	0.77
0.5				4264	840	2.02	3895	790	1.36	3508	743	1.14	3092	697	0.84			
0.6				4023	840	1.87	3644	790	1.24	3210	743	1.01						
0.7				3764	840	1.72	3361	790	1.11									
0.8				3484	840	1.56	3045	790	0.98									

DBC120*S HIGH STATIC HORIZONTAL¹

ESP, In H ₂ O	TURNS OPEN																	
	0			1			2			3			4			5		
	CFM	RPM	BHP	CFM	RPM	BHP	CFM	RPM	BHP	CFM	RPM	BHP	CFM	RPM	BHP	CFM	RPM	BHP
0.8							4922	984	2.85	4477	931	2.45	4010	882	2.06	3432	830	1.52
0.9							4722	984	2.70	4248	931	2.28	3744	882	1.89	3106	830	1.35
1.0							4507	984	2.54	3998	931	2.11	3440	882	1.70			
1.1				4607	1031	2.88	4277	984	2.37	3727	931	1.93	3099	882	1.49			
1.2				4388	1031	2.70	4032	984	2.20	3436	931	1.74						
1.3				4169	1031	2.52	3772	984	2.02	3124	931	1.56						
1.4				3950	1031	2.36	3497	984	1.85									
1.5				3731	1031	2.19	3208	984	1.67									
1.6	4078	1069	2.94	3511	1031	2.04	2904	984	1.50									
1.7	3828	1069	2.72	3290	1031	1.89												
1.8	3567	1069	2.51	3070	1031	1.75												

¹To operate below 0.8" H₂O external static pressure, motor and blower sheave must be changed to VL40 and AK74H respectively, or equivalents

DBC120*V STANDARD STATIC DOWNSHOT¹

ESP, In H ₂ O	TURNS OPEN																	
	0			1			2			3			4			5		
	CFM	RPM	BHP	CFM	RPM	BHP	CFM	RPM	BHP	CFM	RPM	BHP	CFM	RPM	BHP	CFM	RPM	BHP
0.1										4783	743	1.80	4468	697	1.39	4123	651	1.21
0.2							4939	790	1.93	4594	743	1.69	4242	697	1.29	3873	651	1.11
0.3							4733	790	1.81	4376	743	1.57	3987	697	1.18	3585	651	0.99
0.4							4510	790	1.68	4128	743	1.44	3701	697	1.06	3257	651	0.87
0.5							4268	790	1.55	3851	743	1.30	3385	697	0.94			
0.6							4009	790	1.42	3545	743	1.16	3038	697	0.82			
0.7				4195	840	1.98	3731	790	1.28	3210	743	1.01						
0.8				3935	840	1.82	3435	790	1.15									

DBC120*S HIGH STATIC DOWNSHOT

ESP, In H ₂ O	TURNS OPEN																	
	0			1			2			3			4			5		
	CFM	RPM	BHP	CFM	RPM	BHP	CFM	RPM	BHP	CFM	RPM	BHP	CFM	RPM	BHP	CFM	RPM	BHP
0.8										4867	931	2.74	4322	882	2.28	3922	830	1.80
0.9										4619	931	2.55	4074	882	2.11	3674	830	1.66
1.0							4894	984	2.83	4371	931	2.37	3743	882	1.89	3343	830	1.48
1.1							4646	984	2.64	4123	931	2.19	3326	882	1.63			
1.2							4364	984	2.43	3875	931	2.02						
1.3				4705	1031	2.96	4049	984	2.21	3627	931	1.86						
1.4				4434	1031	2.74	3700	984	1.98	3379	931	1.71						
1.5				4138	1031	2.50	3317	984	1.74	3131	931	1.56						
1.6				3817	1031	2.26												
1.7				3472	1031	2.01												
1.8	4058	1069	2.90	3102	1031	1.77												

¹To operate below 0.8" H₂O external static pressure, motor and blower sheave must be changed to VL40 and AK74H respectively, or equivalents

APPENDIX A BLOWER PERFORMANCE DATA

12.5 TON AC

DBC150°V STANDARD STATIC HORIZONTAL

ESP, In H ₂ O	TURNS OPEN																	
	0			1			2			3			4			5		
	CFM	RPM	BHP	CFM	RPM	BHP	CFM	RPM	BHP	CFM	RPM	BHP	CFM	RPM	BHP	CFM	RPM	BHP
0.1				5229	865	2.69	4949	822	2.46	4665	777	1.76	4384	732	1.57	4080	686	1.21
0.2				5101	865	2.60	4809	822	2.36	4515	777	1.67	4218	732	1.48	3896	686	1.14
0.3	5254	905	3.03	4959	865	2.50	4652	822	2.25	4345	777	1.58	4028	732	1.38			
0.4	5105	905	2.91	4803	865	2.40	4478	822	2.14	4154	777	1.48	3812	732	1.28			
0.5	4949	905	2.78	4634	865	2.28	4288	822	2.02	3943	777	1.37						
0.6	4784	905	2.65	4451	865	2.16	4080	822	1.89									
0.7	4610	905	2.52	4254	865	2.04	3856	822	1.76									
0.8	4429	905	2.39	4043	865	1.91												

DBC150°S HIGH STATIC HORIZONTAL¹

ESP, In H ₂ O	TURNS OPEN																	
	0			1			2			3			4			5		
	CFM	RPM	BHP	CFM	RPM	BHP	CFM	RPM	BHP	CFM	RPM	BHP	CFM	RPM	BHP	CFM	RPM	BHP
0.8							6164	1068	5.04	5873	1030	4.06	5526	990	3.36	5160	948	3.00
0.9							6051	1068	4.91	5736	1030	3.92	5379	990	3.23	4977	948	2.85
1.0							5925	1068	4.76	5582	1030	3.77	5205	990	3.09	4770	948	2.69
1.1							5783	1068	4.61	5412	1030	3.61	5004	990	2.92	4539	948	2.51
1.2				6017	1106	4.93	5628	1068	4.43	5225	1030	3.43	4778	990	2.75	4285	948	2.33
1.3				5858	1106	4.75	5457	1068	4.25	5023	1030	3.24	4525	990	2.55	4007	948	2.13
1.4	6019	1144	4.99	5691	1106	4.56	5273	1068	4.06	4803	1030	3.05	4246	990	2.35			
1.5	5864	1144	4.81	5514	1106	4.37	5074	1068	3.85	4568	1030	2.85	3940	990	2.14			
1.6	5700	1144	4.63	5328	1106	4.17	4860	1068	3.64	4316	1030	2.64						
1.7	5528	1144	4.45	5133	1106	3.97	4632	1068	3.42	4047	1030	2.43						
1.8	5348	1144	4.26	4928	1106	3.77	4389	1068	3.19	3762	1030	2.22						

¹To operate below 0.8" H₂O external static pressure, motor and blower sheave must be changed to VP44 and AK79H respectively, or equivalents

DBC150°V STANDARD STATIC DOWNSHOT

ESP, In H ₂ O	TURNS OPEN																	
	0			1			2			3			4			5		
	CFM	RPM	BHP	CFM	RPM	BHP	CFM	RPM	BHP	CFM	RPM	BHP	CFM	RPM	BHP	CFM	RPM	BHP
0.1										5638	777	2.36	5275	732	2.09	4903	686	1.59
0.2										5432	777	2.22	5059	732	1.95	4676	686	1.48
0.3																		
0.4				5760	865	3.09	5392	822	2.77	4979	777	1.94	4562	732	1.67	4112	686	1.23
0.5				5555	865	2.94	5164	822	2.61	4733	777	1.80	4282	732	1.51	3775	686	1.09
0.6				5342	865	2.78	4931	822	2.44	4472	777	1.65	3981	732	1.36			
0.7				5123	865	2.62	4691	822	2.28	4199	777	1.50						
0.8				4897	865	2.46	4446	822	2.12	3912	777	1.36						

DBC150°S HIGH STATIC DOWNSHOT¹

ESP, In H ₂ O	TURNS OPEN																	
	0			1			2			3			4			5		
	CFM	RPM	BHP	CFM	RPM	BHP	CFM	RPM	BHP	CFM	RPM	BHP	CFM	RPM	BHP	CFM	RPM	BHP
0.8													6028	990	3.81	5535	948	3.31
0.9													5810	990	3.61	5306	948	3.12
1.0													6254	1030	4.46	5577	990	3.91
1.1													6054	1030	4.25	5328	990	3.70
1.2													5844	1030	4.03	5063	990	3.48
1.3							6028	1068	4.88	5624	1030	3.81	4783	990	2.75	4174	948	2.25
1.4							5803	1068	4.63	5394	1030	3.59	4487	990	2.53	3837	948	2.02
1.5				6145	1106	5.07	5568	1068	4.37	5155	1030	3.37	4175	990	2.30			
1.6				5939	1106	4.84	5323	1068	4.11	4905	1030	3.14	3848	990	2.08			
1.7				5725	1106	4.60	5068	1068	3.85	4646	1030	2.91						
1.8	5969	1144	4.93	5505	1106	4.36	4803	1068	3.58	4377	1030	2.69						

¹To operate below 0.8" H₂O external static pressure, motor and blower sheave must be changed to VP44 and AK79H respectively, or equivalents

APPENDIX A BLOWER PERFORMANCE DATA

7.5 TON HP

DBH090°V STANDARD STATIC HORIZONTAL

ESP, In H ₂ O	TURNS OPEN																	
	0			1			2			3			4			5		
	CFM	RPM	BHP	CFM	RPM	BHP	CFM	RPM	BHP	CFM	RPM	BHP	CFM	RPM	BHP	CFM	RPM	BHP
0.1							3758	707	1.23	3479	663	1.07	3170	620	0.86	3000	600	0.69
0.2							3612	707	1.16	3356	663	1.02	3004	620	0.79	2685	600	0.59
0.3				3714	748	1.24	3415	707	1.07	3115	663	0.92	2736	620	0.69			
0.4	3776	786	1.43	3499	748	1.14	3169	707	0.97	2756	663	0.78						
0.5	3560	786	1.32	3225	748	1.02	2872	707	0.85									
0.6	3306	786	1.19	2891	748	0.88	2526	707	0.72									
0.7	3014	786	1.05	2498	748	0.74												
0.8	2685	786	0.90															

DBH090°S HIGH STATIC HORIZONTAL¹

ESP, In H ₂ O	TURNS OPEN																	
	0			1			2			3			4			5		
	CFM	RPM	BHP	CFM	RPM	BHP	CFM	RPM	BHP	CFM	RPM	BHP	CFM	RPM	BHP	CFM	RPM	BHP
0.8													3582	889	1.78	2926	836	1.34
0.9													3144	888	1.52	2659	837	1.20
1.0										3582	939	1.96	2797	888	1.32	2391	828	1.07
1.1							3727	983	2.12	3282	940	1.75	2540	889	1.19			
1.2							3469	985	1.94	2952	942	1.55						
1.3				3779	1038	2.37	3209	987	1.77	2593	943	1.33						
1.4				3520	1041	2.17	2948	990	1.60									
1.5				3249	1044	1.97	2686	993	1.45									
1.6	3590	1090	2.65	2965	1047	1.77	2422	996	1.30									
1.7	3328	1093	2.42	2668	1050	1.58												
1.8	3052	1096	2.20															

¹To operate below 0.8" H₂O external static pressure, motor and blower sheave must be changed to 1VL40 and AK74H respectively, or equivalents

DBH090°V STANDARD STATIC DOWNSHOT

ESP, In H ₂ O	TURNS OPEN																	
	0			1			2			3			4			5		
	CFM	RPM	BHP	CFM	RPM	BHP	CFM	RPM	BHP	CFM	RPM	BHP	CFM	RPM	BHP	CFM	RPM	BHP
0.1													3532	620	1.05	3276	600	0.78
0.2										3601	663	1.13	3264	620	0.93	2947	600	0.67
0.3							3654	707	1.18	3323	663	1.00	2955	620	0.81	2617	600	0.57
0.4				3728	748	1.24	3377	707	1.05	3011	663	0.87	2606	620	0.68			
0.5	3791	786	1.44	3456	748	1.11	3072	707	0.92	2664	663	0.74						
0.6	3519	786	1.29	3159	748	0.98	2740	707	0.79									
0.7	3228	786	1.14	2839	748	0.86												
0.8	2917	786	1.00	2496	748	0.73												

DBH090°S HIGH STATIC DOWNSHOT¹

ESP, In H ₂ O	TURNS OPEN																	
	0			1			2			3			4			5		
	CFM	RPM	BHP	CFM	RPM	BHP	CFM	RPM	BHP	CFM	RPM	BHP	CFM	RPM	BHP	CFM	RPM	BHP
0.8													3726	889	1.87	3347	836	1.59
0.9													3575	888	1.78	3078	837	1.43
1.0										3782	939	2.10	3345	888	1.64	2808	838	1.28
1.1										3549	940	1.94	3035	889	1.46	2539	840	1.14
1.2										3310	942	1.77	2645	891	1.25			
1.3							3631	987	2.05	3064	943	1.62						
1.4							3398	990	1.89	2811	944	1.46						
1.5				3727	1044	2.32	3152	993	1.73	2552	945	1.31						
1.6				3506	1047	2.15	2896	996	1.57									
1.7	3796	1093	2.82	3276	1050	1.98	2628	1000	1.41									
1.8	3574	1096	2.62	3038	1053	1.81												

¹To operate below 0.8" H₂O external static pressure, motor and blower sheave must be changed to 1VL40 and AK74H respectively, or equivalents

APPENDIX A BLOWER PERFORMANCE DATA

8.5 TON HP

DBH102°V STANDARD STATIC HORIZONTAL

ESP, In H ₂ O	TURNS OPEN																	
	0			1			2			3			4			5		
	CFM	RPM	BHP	CFM	RPM	BHP	CFM	RPM	BHP	CFM	RPM	BHP	CFM	RPM	BHP	CFM	RPM	BHP
0.1										4038	699	1.63	3759	656	1.37	3485	615	1.16
0.2							4161	743	1.83	3846	699	1.54	3559	655	1.29	3269	617	1.09
0.3							3969	743	1.74	3631	699	1.45	3334	659	1.20	3018	617	1.01
0.4				4075	788	1.94	3775	745	1.63	3428	704	1.35	3095	661	1.11			
0.5				3883	788	1.83	3571	749	1.54	3194	704	1.26	2784	661	1.01			
0.6	4017	832	2.08	3682	789	1.73	3340	749	1.43	2877	704	1.13						
0.7	3806	832	1.96	3462	793	1.61	3039	749	1.30									
0.8	3589	835	1.82	3170	793	1.47												

DBH102°S HIGH STATIC HORIZONTAL¹

ESP, In H ₂ O	TURNS OPEN																	
	0			1			2			3			4			5		
	CFM	RPM	BHP	CFM	RPM	BHP	CFM	RPM	BHP	CFM	RPM	BHP	CFM	RPM	BHP	CFM	RPM	BHP
0.8										4012	943	2.53	3592	893	2.05	3125	842	1.62
0.9										3832	945	2.40	3366	895	1.93			
1.0							4035	997	2.80	3645	948	2.27	3155	897	1.80			
1.1							3833	998	2.65	3399	948	2.13	2881	897	1.68			
1.2				4067	1044	3.06	3663	998	2.51	3235	950	2.01						
1.3				3866	1047	2.90	3469	1001	2.38	2966	952	1.86						
1.4				3720	1051	2.77	3273	1003	2.24									
1.5				3527	1051	2.61												
1.6	3826	1107	3.14	3320	1052	2.45												
1.7	3664	1110	2.98	3188	1055	2.31												
1.8	3471	1110	2.83	2797	1058	2.10												

¹To operate below 0.8" H₂O external static pressure, motor and blower sheave must be changed to 1VL40 and AK794H respectively, or equivalents

DBH102°V STANDARD STATIC DOWNSHOT¹

ESP, In H ₂ O	TURNS OPEN																	
	0			1			2			3			4			5		
	CFM	RPM	BHP	CFM	RPM	BHP	CFM	RPM	BHP	CFM	RPM	BHP	CFM	RPM	BHP	CFM	RPM	BHP
0.1																3933	610	1.29
0.2													4039	655	1.46	3658	611	1.20
0.3										4172	693	1.66	3763	655	1.35	3355	611	1.10
0.4										3914	698	1.54	3473	655	1.24	3006	612	0.99
0.5							4032	742	1.73	3629	698	1.42	3138	657	1.12			
0.6				4169	787	1.95	3740	743	1.60	3287	699	1.28						
0.7				3908	787	1.81	3428	743	1.46	2875	704	1.14						
0.8	4038	832	2.05	3597	792	1.66	3071	748	1.32									

DBH102°S HIGH STATIC DOWNSHOT

ESP, In H ₂ O	TURNS OPEN																	
	0			1			2			3			4			5		
	CFM	RPM	BHP	CFM	RPM	BHP	CFM	RPM	BHP	CFM	RPM	BHP	CFM	RPM	BHP	CFM	RPM	BHP
0.8																3841	837	1.98
0.9													4060	890	2.33	3532	840	1.82
1.0													3846	893	2.19	3253	843	1.67
1.1										4128	941	2.61	3521	893	2.00			
1.2										3903	942	2.44	3223	895	1.83			
1.3										3611	945	2.25						
1.4							3904	994	2.67	3320	948	2.07						
1.5							3643	998	2.48									
1.6				3943	1042	2.94	3356	1002	2.28									
1.7				3685	1046	2.74	3175	1004	2.11									
1.8	4151	1102	3.49	3444	1053	2.56												

¹To operate below 0.8" H₂O external static pressure, motor and blower sheave must be changed to 1VL40 and AK794H respectively, or equivalents

APPENDIX A BLOWER PERFORMANCE DATA

10 TON HP

DBHC120°V STANDARD STATIC HORIZONTAL

ESP, In H ₂ O	TURNS OPEN																	
	0			1			2			3			4			5		
	CFM	RPM	BHP	CFM	RPM	BHP	CFM	RPM	BHP	CFM	RPM	BHP	CFM	RPM	BHP	CFM	RPM	BHP
0.1							4870	736	2.07	4582	697	1.77	4265	654	1.46	3926	610	1.24
0.2							4671	738	1.96	4368	698	1.66	4037	654	1.37	3666	610	1.17
0.3							4464	739	1.86	4129	698	1.56	3781	657	1.27			
0.4				4639	781	2.13	4311	742	1.76	3941	698	1.46	3553	658	1.18			
0.5				4400	784	2.01	4013	743	1.64	3654	701	1.35	3268	660	1.08			
0.6				4246	786	1.90	3858	744	1.55	3387	703	1.24						
0.7				3997	789	1.78	3561	746	1.42									
0.8	4152	830	2.02	3746	791	1.65	3256	747	1.29									

DBH120°S HIGH STATIC HORIZONTAL¹

ESP, In H ₂ O	TURNS OPEN																	
	0			1			2			3			4			5		
	CFM	RPM	BHP	CFM	RPM	BHP	CFM	RPM	BHP	CFM	RPM	BHP	CFM	RPM	BHP	CFM	RPM	BHP
0.8										4964	881	2.76	4421	832	2.16	3857	781	1.72
0.9										4728	882	2.57	4180	832	2.03	3455	781	1.54
1.0										4505	882	2.43	3879	833	1.86			
1.1							4800	931	2.85	4080	885	2.17						
1.2							4573	932	2.68	3932	887	2.08						
1.3				4847	977	3.15	4305	936	2.51									
1.4				4636	981	2.97	3962	937	2.27									
1.5				4369	985	2.77												
1.6	4747	1030	3.35	4045	989	2.54												
1.7	4472	1035	3.12															
1.8	3785	1041	2.60															

¹To operate below 0.8" H₂O external static pressure, motor and blower sheave must be changed to 1VL40 and AK79H respectively, or equivalents

DBH120°V STANDARD STATIC DOWNSHOT¹

ESP, In H ₂ O	TURNS OPEN																	
	0			1			2			3			4			5		
	CFM	RPM	BHP	CFM	RPM	BHP	CFM	RPM	BHP	CFM	RPM	BHP	CFM	RPM	BHP	CFM	RPM	BHP
0.1													4836	649	1.73	4463	610	1.41
0.2										4976	692	1.97	4557	650	1.60	4177	610	1.30
0.3										4641	693	1.82	4213	653	1.47	3783	610	1.17
0.4							4818	736	2.08	4382	694	1.68	3947	655	1.34	3447	610	1.05
0.5							4521	739	1.93	4017	696	1.53	3553	656	1.20			
0.6				4673	780	2.17	4232	741	1.77	3747	698	1.40						
0.7				4393	784	2.01	3835	745	1.59	3329	699	1.24						
0.8	4614	823	2.32	4105	786	1.86												

DBH120°S HIGH STATIC DOWNSHOT

ESP, In H ₂ O	TURNS OPEN																	
	0			1			2			3			4			5		
	CFM	RPM	BHP	CFM	RPM	BHP	CFM	RPM	BHP	CFM	RPM	BHP	CFM	RPM	BHP	CFM	RPM	BHP
0.8													4605	836	2.37	3999	786	1.82
0.9													4290	837	2.19	3624	787	1.64
1.0										4689	887	2.60	3975	837	2.01			
1.1							4880	930	2.94	4292	887	2.29						
1.2							4728	936	2.88	3942	887	2.08						
1.3							4384	940	2.62									
1.4				4773	986	3.20	4077	942	2.42									
1.5				4424	989	2.92												
1.6				4065	992	2.65												
1.7	4446	1035	3.16															
1.8	4169	1040	2.94															

¹To operate below 0.8" H₂O external static pressure, motor and blower sheave must be changed to 1VL40 and AK79H respectively, or equivalents

APPENDIX A BLOWER PERFORMANCE DATA

12.5 TON HP

DBH150*V STANDARD STATIC HORIZONTAL

ESP, In H ₂ O	TURNS OPEN																	
	0			1			2			3			4			5		
	CFM	RPM	BHP	CFM	RPM	BHP	CFM	RPM	BHP	CFM	RPM	BHP	CFM	RPM	BHP	CFM	RPM	BHP
0.1				5717	814	3.01	5458	774	2.24	5117	731	1.99	4780	690	1.54	4440	645	1.35
0.2				5580	814	2.91	5261	774	2.11	4885	731	1.85	4538	690	1.42	4181	645	1.23
0.3				5409	814	2.78	5042	774	1.98	4640	731	1.71	4276	690	1.30	3892	645	1.11
0.4	5541	856	2.91	5204	814	2.63	4801	774	1.83	4383	731	1.57	3994	690	1.18			
0.5	5331	856	2.76	4964	814	2.46	4538	774	1.68	4114	731	1.43						
0.6	5108	856	2.60	4690	814	2.27	4254	774	1.53	3831	731	1.29						
0.7	4872	856	2.43	4382	814	2.07	3948	774	1.37									
0.8	4622	856	2.26	4039	814	1.86												

DBH150*S HIGH STATIC HORIZONTAL

ESP, In H ₂ O	TURNS OPEN																	
	0			1			2			3			4			5		
	CFM	RPM	BHP	CFM	RPM	BHP	CFM	RPM	BHP	CFM	RPM	BHP	CFM	RPM	BHP	CFM	RPM	BHP
0.8							6109	1013	4.29	5785	975	3.57	5443	933	3.22	4992	895	2.81
0.9							5944	1013	4.11	5361	975	3.20	5092	933	2.93	4751	895	2.62
1.0				6149	1052	4.99	5761	1013	3.93	4989	975	2.89	4747	933	2.65	4472	895	2.41
1.1				5961	1052	4.78	5559	1013	3.73	4669	975	2.64	4407	933	2.40	4154	895	2.18
1.2	6126	1088	5.02	5759	1052	4.55	5338	1013	3.51	4402	975	2.45	4072	933	2.16	3798	895	1.94
1.3	5936	1088	4.81	5544	1052	4.32	5099	1013	3.29	4188	975	2.29	3742	933	1.94			
1.4	5738	1088	4.58	5316	1052	4.08	4840	1013	3.06	4025	975	2.18						
1.5	5531	1088	4.36	5074	1052	3.83	4563	1013	2.82	3915	975	2.10						
1.6	5317	1088	4.13	4819	1052	3.57	4266	1013	2.58									
1.7	5094	1088	3.90	4550	1052	3.32	3951	1013	2.33									
1.8	4863	1088	3.67	4269	1052	3.06												

¹To operate below 0.8" H₂O external static pressure, motor and blower sheave must be changed to VP44 and AK84H respectively, or equivalents

DBH150*V STANDARD STATIC DOWNSHOT

ESP, In H ₂ O	TURNS OPEN																	
	0			1			2			3			4			5		
	CFM	RPM	BHP	CFM	RPM	BHP	CFM	RPM	BHP	CFM	RPM	BHP	CFM	RPM	BHP	CFM	RPM	BHP
0.1							6178	762	2.72	5793	721	2.42	5400	681	1.84	4957	642	1.59
0.2							5963	762	2.57	5529	721	2.24	5102	681	1.69	4625	642	1.43
0.3							5716	762	2.40	5241	721	2.06	4778	681	1.53	4276	642	1.27
0.4							5439	762	2.22	4929	721	1.87	4429	681	1.36	3910	642	1.12
0.5				5581	805	2.90	5131	762	2.02	4593	721	1.68	4053	681	1.20			
0.6				5289	805	2.68	4793	762	1.82	4233	721	1.48						
0.7				4980	805	2.46	4423	762	1.61	3848	721	1.29						
0.8	5141	840	2.87	4655	805	2.24	4023	762	1.40									

DBH150*S HIGH STATIC DOWNSHOT

ESP, In H ₂ O	TURNS OPEN																	
	0			1			2			3			4			5		
	CFM	RPM	BHP	CFM	RPM	BHP	CFM	RPM	BHP	CFM	RPM	BHP	CFM	RPM	BHP	CFM	RPM	BHP
0.8													6078	935	3.79	5656	895	3.36
0.9										6269	972	4.01	5819	935	3.55	5379	895	3.12
1.0										6022	972	3.78	5545	935	3.31	5082	895	2.88
1.1							6226	1011	5.03	5760	972	3.54	5255	935	3.06	4765	895	2.63
1.2							5970	1011	4.73	5482	972	3.30	4950	935	2.82	4428	895	2.37
1.3				6118	1047	4.95	5711	1011	4.45	5189	972	3.05	4629	935	2.57	4070	895	2.12
1.4				5870	1047	4.67	5451	1011	4.16	4880	972	2.80	4293	935	2.32			
1.5	6096	1083	4.98	5624	1047	4.40	5190	1011	3.89	4556	972	2.56	3942	935	2.08			
1.6	5861	1083	4.71	5377	1047	4.14	4926	1011	3.63	4216	972	2.31						
1.7	5624	1083	4.45	5131	1047	3.88	4661	1011	3.37	3861	972	2.07						
1.8	5385	1083	4.20	4886	1047	3.64	4393	1011	3.12									

¹To operate below 0.8" H₂O external static pressure, motor and blower sheave must be changed to VP44 and AK84H respectively, or equivalents

APPENDIX B ELECTRICAL DATA

ELECTRICAL DATA

Model Number	Electrical Rating	Compressor			Outdoor Fan Motor			Indoor Fan Motor			Optional Electric Heat			Optional Powered Convenience	Optional Power	Power Supply	
		QTY	RLA	LRA	QTY	HP	FLA	Type	HP	FLA	Part #	KW*	FLA	FLA	FLA	MCA	MOP
DBC0903S	208/230/3/60	2	13.1	83.1	2	0.33	2	2 speed Belt Drive High Static	3	9.1	-	-	-	-	-	42.7/42.7	50/50
											-	-	-	9.6/8.7	-	52.3/51.4	60/60
											-	-	-	-	3.3/3.0	46.0/45.7	50/50
											-	-	-	9.6/8.7	3.3/3.0	55.6/54.4	60/60
											-	-	-	-	-	50.5/56.5	60/60
											EH*B-3M15	11.3/15.0	31.3/36.1	9.6/8.7	-	62.5/67.4	70/70
														-	3.3/3.0	54.6/60.2	60/70
														9.6/8.7	3.3/3.0	66.6/71.1	70/80
											EH*B-3M30	22.5/30.0	62.5/72.2	-	-	89.6/102	90/110
														9.6/8.7	-	102/112	110/125
														-	3.3/3.0	93.7/105	100/110
											EH*B-3M45	33.8/45.0	93.8/108	9.6/8.7	-	106/116	110/125
-	-	129/147	150/150														
-	3.3/3.0	141/158	150/175														
-	-	-	9.6/8.7	3.3/3.0	133/150	150/175											
-	-	-	9.6/8.7	3.3/3.0	145/161	150/175											
DBC0903V	208/230/3/60	2	13.1	83.1	2	0.33	2	2 speed Belt Drive Standard Static	2	6	-	-	-	-	-	39.6/39.6	50/50
											-	-	-	9.6/8.7	-	49.2/48.3	60/60
											-	-	-	-	3.3/3.0	42.9/42.6	50/50
											-	-	-	9.6/8.7	3.3/3.0	52.5/51.3	60/60
											-	-	-	-	-	46.6/52.6	50/60
											EH*B-3M15	11.3/15.0	31.3/36.1	9.6/8.7	-	58.6/63.5	60/70
														-	3.3/3.0	50.7/56.4	60/60
														9.6/8.7	3.3/3.0	62.7/67.2	70/70
											EH*B-3M30	22.5/30.0	62.5/72.2	-	-	85.7/97.7	90/100
														9.6/8.7	-	97.7/109	100/110
														-	3.3/3.0	89.8/101	90/110
											EH*B-3M45	33.8/45.0	93.8/108	9.6/8.7	-	102/112	110/125
-	-	125/143	125/150														
-	3.3/3.0	137/154	150/175														
-	-	-	9.6/8.7	3.3/3.0	129/147	150/150											
-	-	-	9.6/8.7	3.3/3.0	141/157	150/175											
DBC0904S	460/3/60	2	6.1	41	2	0.33	0.85	2 speed Belt Drive High Static	3	4.3	-	-	-	-	-	19.7	25
											-	-	-	4.3	-	24	30
											-	-	-	-	1	20.7	25
											-	-	-	4.3	1	25	30
											-	-	-	-	-	27.9	30
											EH*B-4M15	15	18	4.3	-	33.3	35
														-	1	29.2	30
														4.3	1	34.6	35
											EH*B-4M30	30	36.1	-	-	50.5	60
														4.3	-	55.9	60
														-	1	51.7	60
											EH*B-4M45	45	54.1	4.3	-	57.1	60
-	-	73	80														
-	1	78.4	80														
-	-	-	4.3	1	74.3	80											
-	-	-	4.3	1	79.7	80											
DBC0904V	460/3/60	2	6.1	41	2	0.33	0.85	2 speed Belt Drive Standard Static	2	2.9	-	-	-	-	-	18.3	20
											-	-	-	4.3	-	22.6	25
											-	-	-	-	1	19.3	20
											-	-	-	4.3	1	23.6	25
											-	-	-	-	-	26.2	30
											EH*B-4M15	15	18	4.3	-	31.6	35
														-	1	27.4	30
														4.3	1	32.8	35
											EH*B-4M30	30	36.1	-	-	48.7	50
														4.3	-	54.1	60
														-	1	50	50
											EH*B-4M45	45	54.1	4.3	-	55.4	60
-	-	71.3	80														
-	1	76.7	80														
-	-	-	4.3	1	72.5	80											
-	-	-	4.3	1	77.9	80											

APPENDIX B ELECTRICAL DATA

ELECTRICAL DATA

Model Number	Electrical Rating	Compressor			Outdoor Fan Motor			Indoor Fan Motor			Optional Electric Heat			Optional Powered Convenience Outlet	Optional Power Exhaust	Power Supply	
		QTY	RLA	LRA	QTY	HP	FLA	Type	HP	FLA	Part #	KW*	FLA	FLA	FLA	MCA	MOP
DBC0907S	575/3/60	2	4.4	33	2	0.33	0.67	2 speed Belt Drive High Static	3	3.5	-	-	-	-	-	14.6	15
											-	-	-	3.5	-	18.1	20
											-	-	-	-	1.2	15.8	20
											-	-	-	3.5	1.2	19.3	20
											-	-	-	-	-	22.4	25
											EH*B-7M15	15	14.4	3.5	-	26.8	30
														-	1.2	23.9	25
														3.5	1.2	28.3	30
											EH*B-7M30	30	28.9	-	-	40.5	45
														3.5	-	44.8	45
														-	1.2	42	45
											EH*B-7M45	45	43.3	3.5	-	46.3	50
														-	-	58.5	60
														3.5	-	62.9	70
														-	1.2	60	70
-	-	-	3.5	1.2	64.4	70											
DBC0907V	575/3/60	2	4.4	33	2	0.33	0.67	2 speed Belt Drive Standard Static	2	2.4	-	-	-	-	-	13.5	15
											-	-	-	3.5	-	17	20
											-	-	-	-	1.2	14.7	15
											-	-	-	3.5	1.2	18.2	20
											-	-	-	-	-	21	25
											EH*B-7M15	15	14.4	3.5	-	25.4	30
														-	1.2	22.5	25
														3.5	1.2	26.9	30
											EH*B-7M30	30	28.9	-	-	39.1	40
														3.5	-	43.5	45
														-	1.2	40.6	45
											EH*B-7M45	45	43.3	3.5	-	45	45
														-	-	57.1	60
														3.5	-	61.5	70
														-	1.2	58.6	60
-	-	-	3.5	1.2	63	70											
DBC1023S	208/230/3/60	2	14.5	98	2	0.33	2	2 speed Belt Drive High Static	3	9.1	-	-	-	-	-	45.7/45.7	60/60
											-	-	-	9.6/8.7	-	55.3/54.4	60/60
											-	-	-	-	3.3/3.0	49.0/48.7	60/60
											-	-	-	9.6/8.7	3.3/3.0	58.6/57.4	60/60
											-	-	-	-	-	50.5/56.5	60/60
											EH*B-3M15	11.3/15.0	31.3/36.1	9.6/8.7	-	62.5/67.4	70/70
														-	3.3/3.0	54.6/60.2	60/70
														9.6/8.7	3.3/3.0	66.6/71.1	70/80
											EH*B-3M30	22.5/30.0	62.5/72.2	-	-	89.6/102	90/110
														9.6/8.7	-	102/112	110/125
														-	3.3/3.0	93.7/105	100/110
											EH*B-3M45	33.8/45.0	93.8/108	9.6/8.7	-	106/116	110/125
														-	-	129/147	150/150
														-	3.3/3.0	141/158	150/175
														9.6/8.7	3.3/3.0	133/150	150/175
-	-	-	9.6/8.7	3.3/3.0	145/161	150/175											
DBC1023V	208/230/3/60	2	14.5	98	2	0.33	2	2 speed Belt Drive Standard Static	2	6	-	-	-	-	-	42.6/42.6	50/50
											-	-	-	9.6/8.7	-	52.2/51.3	60/60
											-	-	-	-	3.3/3.0	45.9/45.6	50/50
											-	-	-	9.6/8.7	3.3/3.0	55.5/54.3	60/60
											-	-	-	-	-	46.6/52.6	50/60
											EH*B-3M15	11.3/15.0	31.3/36.1	9.6/8.7	-	58.6/63.5	60/70
														-	3.3/3.0	50.7/56.4	60/60
														9.6/8.7	3.3/3.0	62.7/67.2	70/70
											EH*B-3M30	22.5/30.0	62.5/72.2	-	-	85.7/97.7	90/100
														9.6/8.7	-	97.7/109	100/110
														-	3.3/3.0	89.8/101	90/110
											EH*B-3M45	33.8/45.0	93.8/108	9.6/8.7	-	102/112	110/125
														-	-	125/143	125/150
														-	3.3/3.0	137/154	150/175
														9.6/8.7	3.3/3.0	129/147	150/150
-	-	-	9.6/8.7	3.3/3.0	141/157	150/175											

APPENDIX B ELECTRICAL DATA

ELECTRICAL DATA

Model Number	Electrical Rating	Compressor			Outdoor Fan Motor			Indoor Fan Motor			Optional Electric Heat			Optional Powered Convenience Outlet	Optional Power Exhaust	Power Supply	
		QTY	RLA	LRA	QTY	HP	FLA	Type	HP	FLA	Part #	KW*	FLA	FLA	FLA	MCA	MOP
DBC1024S	460/3/60	2	6.3	55	2	0.33	0.85	2 speed Belt Drive High Static	3	4.3	-	-	-	-	-	20.3	25
											-	-	-	4.3	-	24.6	30
											-	-	-	-	1	21.3	25
											-	-	-	4.3	1	25.6	30
											-	-	-	-	-	27.9	30
											EH*B-4M15	15	18	4.3	-	33.3	35
														-	1	29.2	30
														4.3	1	34.6	35
											EH*B-4M30	30	36.1	-	-	50.5	60
														4.3	-	55.9	60
														-	1	51.7	60
											EH*B-4M45	45	54.1	4.3	1	57.1	60
														-	-	73	80
														4.3	-	78.4	80
														-	1	74.3	80
-	-	-	4.3	1	79.7	80											
DBC1024V	460/3/60	2	6.3	55	2	0.33	0.85	2 speed Belt Drive Standard Static	2	2.9	-	-	-	-	-	18.9	25
											-	-	-	4.3	-	23.2	25
											-	-	-	-	1	19.9	25
											-	-	-	4.3	1	24.2	25
											-	-	-	-	-	26.2	30
											EH*B-4M15	15	18	4.3	-	31.6	35
														-	1	27.4	30
														4.3	1	32.8	35
											EH*B-4M30	30	36.1	-	-	48.7	50
														4.3	-	54.1	60
														-	1	50	50
											EH*B-4M45	45	54.1	4.3	1	55.4	60
														-	-	71.3	80
														4.3	-	76.7	80
														-	1	72.5	80
-	-	-	4.3	1	77.9	80											
DBC1027S	575/3/60	2	6	41	2	0.33	0.67	2 speed Belt Drive High Static	3	3.5	-	-	-	-	-	18.4	20
											-	-	-	3.5	-	21.9	25
											-	-	-	-	1.2	19.6	20
											-	-	-	3.5	1.2	23.1	25
											-	-	-	-	-	22.4	25
											EH*B-7M15	15	14.4	3.5	-	26.8	30
														-	1.2	23.9	25
														3.5	1.2	28.3	30
											EH*B-7M30	30	28.9	-	-	40.5	45
														3.5	-	44.8	45
														-	1.2	42	45
											EH*B-7M45	45	43.3	3.5	1.2	46.3	50
														-	-	58.5	60
														3.5	-	62.9	70
														-	1.2	60	70
-	-	-	3.5	1.2	64.4	70											
DBC1027V	575/3/60	2	6	41	2	0.33	0.67	2 speed Belt Drive Standard Static	2	2.4	-	-	-	-	-	17.3	20
											-	-	-	3.5	-	20.8	25
											-	-	-	-	1.2	18.5	20
											-	-	-	3.5	1.2	22	25
											-	-	-	-	-	21	25
											EH*B-7M15	15	14.4	3.5	-	25.4	30
														-	1.2	22.5	25
														3.5	1.2	26.9	30
											EH*B-7M30	30	28.9	-	-	39.1	40
														3.5	-	43.5	45
														-	1.2	40.6	45
											EH*B-7M45	45	43.3	3.5	1.2	45	45
														-	-	57.1	60
														3.5	-	61.5	70
														-	1.2	58.6	60
-	-	-	3.5	1.2	63	70											

APPENDIX B ELECTRICAL DATA

ELECTRICAL DATA

Model Number	Electrical Rating	Compressor			Outdoor Fan Motor			Indoor Fan Motor			Optional Electric Heat			Optional Powered Convenience Outlet	Optional Power Exhaust	Power Supply	
		QTY	RLA	LRA	QTY	HP	FLA	Type	HP	FLA	Part #	KW*	FLA	FLA	FLA	MCA	MOP
DBC1203S	208/230/3/60	2	16	110	2	0.33	2	2 speed Belt Drive High Static	3	9.1	-	-	-	-	-	49.0/49.0	60/60
											-	-	-	9.6/8.7	-	58.6/57.7	70/70
											-	-	-	-	3.3/3.0	52.3/52.0	60/60
											-	-	-	9.6/8.7	3.3/3.0	61.9/60.7	70/70
											-	-	-	-	-	50.5/56.5	60/60
											EH*B-3M16	11.3/15.0	31.3/36.1	9.6/8.7	-	62.5/67.4	70/70
														-	3.3/3.0	54.6/60.2	60/70
														9.6/8.7	3.3/3.0	66.6/71.1	70/80
											EH*B-3M31	22.5/30.0	62.5/72.2	-	-	89.6/102	90/110
														9.6/8.7	-	102/112	110/125
														-	3.3/3.0	93.7/105	100/110
											EH*B-3M46	33.8/45.0	93.8/108	9.6/8.7	-	106/116	110/125
														-	3.3/3.0	129/147	150/150
														9.6/8.7	-	141/158	150/175
											-	-	-	-	3.3/3.0	133/150	150/175
-	-	-	9.6/8.7	3.3/3.0	145/161	150/175											
DBC1203V	208/230/3/60	2	16	110	2	0.33	2	2 speed Belt Drive Standard Static	2	6	-	-	-	-	-	45.9/45.9	60/60
											-	-	-	9.6/8.7	-	55.5/54.6	70/70
											-	-	-	-	3.3/3.0	49.2/48.9	60/60
											-	-	-	9.6/8.7	3.3/3.0	58.8/57.6	70/70
											-	-	-	-	-	46.6/52.6	60/60
											EH*B-3M16	11.3/15.0	31.3/36.1	9.6/8.7	-	58.6/63.5	70/70
														-	3.3/3.0	50.7/56.4	60/60
														9.6/8.7	3.3/3.0	62.7/67.2	70/70
											EH*B-3M31	22.5/30.0	62.5/72.2	-	-	85.7/97.7	90/100
														9.6/8.7	-	97.7/109	100/110
														-	3.3/3.0	89.8/101	90/110
											EH*B-3M46	33.8/45.0	93.8/108	9.6/8.7	-	102/112	110/125
														-	3.3/3.0	125/143	125/150
														9.6/8.7	-	125/143	125/150
											-	-	-	9.6/8.7	-	137/154	150/175
-	-	-	-	3.3/3.0	129/147	150/150											
-	-	-	9.6/8.7	3.3/3.0	141/157	150/175											
DBC1204S	460/3/60	2	7.8	52	2	0.33	0.85	2 speed Belt Drive High Static	3	4.3	-	-	-	-	-	23.5	30
											-	-	-	4.3	-	27.8	35
											-	-	-	-	1	24.5	30
											-	-	-	4.3	1	28.8	35
											-	-	-	-	-	27.9	30
											EH*B-4M16	15	18	4.3	-	33.3	35
														-	1	29.2	30
														4.3	1	34.6	35
											EH*B-4M31	30	36.1	-	-	50.5	60
														4.3	-	55.9	60
														-	1	51.7	60
											EH*B-4M46	45	54.1	4.3	-	57.1	60
														-	-	73	80
														4.3	-	78.4	80
											-	-	-	-	1	74.3	80
-	-	-	4.3	1	79.7	80											
DBC1204V	460/3/60	2	7.8	52	2	0.33	0.85	2 speed Belt Drive Standard Static	2	2.9	-	-	-	-	-	22.1	25
											-	-	-	4.3	-	26.4	30
											-	-	-	-	1	23.1	25
											-	-	-	4.3	1	27.4	30
											-	-	-	-	-	26.2	30
											EH*B-4M16	15	18	4.3	-	31.6	35
														-	1	27.4	30
														4.3	1	32.8	35
											EH*B-4M31	30	36.1	-	-	48.7	50
														4.3	-	54.1	60
														-	1	50	50
											EH*B-4M46	45	54.1	4.3	-	55.4	60
														-	-	71.3	80
														4.3	-	76.7	80
											-	-	-	-	1	72.5	80
-	-	-	4.3	1	77.9	80											

APPENDIX B ELECTRICAL DATA

ELECTRICAL DATA

Model Number	Electrical Rating	Compressor			Outdoor Fan Motor			Indoor Fan Motor			Optional Electric Heat			Optional Powered Convenience Outlet	Optional Power Exhaust	Power Supply	
		QTY	RLA	LRA	QTY	HP	FLA	Type	HP	FLA	Part #	KW*	FLA	FLA	FLA	MCA	MOP
DBC1207S	575/3/60	2	5.7	38.9	2	0.33	0.67	2 speed Belt Drive High Static	3	3.5	-	-	-	-	-	17.7	20
											-	-	-	3.5	-	21.2	25
											-	-	-	-	1.2	18.9	20
											-	-	-	3.5	1.2	22.4	25
											-	-	-	-	-	22.4	25
											EH*B-7M16	15	14.4	3.5	-	26.8	30
														-	1.2	23.9	25
														3.5	1.2	28.3	30
											EH*B-7M31	30	28.9	-	-	40.5	45
														3.5	-	44.8	45
														-	1.2	42	45
											EH*B-7M46	45	43.3	3.5	1.2	46.3	50
-	-	58.5	60														
3.5	-	62.9	70														
-	1.2	60	70														
-	-	-	3.5	1.2	64.4	70											
DBC1207V	575/3/60	2	5.7	38.9	2	0.33	0.67	2 speed Belt Drive Standard Static	2	2.4	-	-	-	-	-	16.6	20
											-	-	-	3.5	-	20.1	25
											-	-	-	-	1.2	17.8	20
											-	-	-	3.5	1.2	21.3	25
											-	-	-	-	-	21	25
											EH*B-7M16	15	14.4	3.5	-	25.4	30
														-	1.2	22.5	25
														3.5	1.2	26.9	30
											EH*B-7M31	30	28.9	-	-	39.1	40
														3.5	-	43.5	45
														-	1.2	40.6	45
											EH*B-7M46	45	43.3	3.5	1.2	45	45
-	-	57.1	60														
3.5	-	61.5	70														
-	1.2	58.6	60														
-	-	-	3.5	1.2	63	70											
DBC1503S	208/230/3/60	2	19	123	2	0.5	2.7	2 speed Belt Drive High Static	5	14	-	-	-	-	-	62.2/62.2	80/80
											-	-	-	9.6/8.7	-	71.8/70.9	90/80
											-	-	-	-	3.3/3.0	65.5/65.2	80/80
											-	-	-	9.6/8.7	3.3/3.0	75.1/73.9	90/80
											-	-	-	-	-	62.2/62.6	80/80
											EH*B-3M16	11.3/15.0	31.3/36.1	9.6/8.7	-	71.8/73.5	90/80
														-	3.3/3.0	65.5/66.4	80/80
														9.6/8.7	3.3/3.0	75.1/77.2	90/80
											EH*B-3M31	22.5/30.0	62.5/72.2	-	-	95.7/108	100/110
														9.6/8.7	-	108/119	110/125
														-	3.3/3.0	99.8/111	100/125
											EH*B-3M46	33.8/45.0	93.8/108	9.6/8.7	3.3/3.0	112/122	125/125
-	-	135/153	150/175														
9.6/8.7	-	147/164	150/175														
-	3.3/3.0	139/157	150/175														
-	-	-	9.6/8.7	3.3/3.0	151/167	175/175											
DBC1503V	208/230/3/60	2	19	123	2	0.5	2.7	2 speed Belt Drive Standard Static	3	9.1	-	-	-	-	-	57.3/57.3	70/70
											-	-	-	9.6/8.7	-	66.9/66.0	80/80
											-	-	-	-	3.3/3.0	60.6/60.3	70/70
											-	-	-	9.6/8.7	3.3/3.0	70.2/69.0	80/80
											-	-	-	-	-	57.3/57.3	70/70
											EH*B-3M16	11.3/15.0	31.3/36.1	9.6/8.7	-	66.9/67.4	80/80
														-	3.3/3.0	60.6/60.3	70/70
														9.6/8.7	3.3/3.0	70.2/71.1	80/80
											EH*B-3M31	22.5/30.0	62.5/72.2	-	-	89.6/102	90/110
														9.6/8.7	-	102/112	110/125
														-	3.3/3.0	93.7/105	100/110
											EH*B-3M46	33.8/45.0	93.8/108	9.6/8.7	3.3/3.0	106/116	110/125
-	-	129/147	150/150														
9.6/8.7	-	141/158	150/175														
-	3.3/3.0	133/150	150/175														
-	-	-	9.6/8.7	3.3/3.0	145/161	150/175											

APPENDIX B ELECTRICAL DATA

ELECTRICAL DATA

Model Number	Electrical Rating	Compressor			Outdoor Fan Motor			Indoor Fan Motor			Optional Electric Heat			Optional Powered Convenience Outlet	Optional Power Exhaust	Power Supply	
		QTY	RLA	LRA	QTY	HP	FLA	Type	HP	FLA	Part #	KW*	FLA	FLA	FLA	MCA	MOP
DBC1504S	460/3/60	2	9.7	62	2	0.5	1.4	2 speed Belt Drive High Static	5	6.6	-	-	-	-	-	31.3	40
											-	-	-	4.3	-	35.6	45
											-	-	-	-	1	32.3	40
											-	-	-	4.3	1	36.6	45
											-	-	-	-	-	31.3	40
											-	-	-	4.3	-	36.2	45
											-	-	-	-	1	32.3	40
											-	-	-	4.3	1	37.4	45
											-	-	-	-	-	53.4	60
											-	-	-	4.3	-	58.7	60
											-	-	-	-	1	54.6	60
											-	-	-	4.3	1	60	60
											-	-	-	-	-	75.9	80
											-	-	-	4.3	-	81.3	90
											-	-	-	-	1	77.2	80
-	-	-	4.3	1	82.5	90											
DBC1504V	460/3/60	2	9.7	62	2	0.5	1.4	2 speed Belt Drive Standard Static	3	4.3	-	-	-	-	-	29	35
											-	-	-	4.3	-	33.3	40
											-	-	-	-	1	30	35
											-	-	-	4.3	1	34.3	40
											-	-	-	-	-	29	35
											-	-	-	4.3	-	33.3	40
											-	-	-	-	1	30	35
											-	-	-	4.3	1	34.6	40
											-	-	-	-	-	50.5	60
											-	-	-	4.3	-	55.9	60
											-	-	-	-	1	51.7	60
											-	-	-	4.3	1	57.1	60
											-	-	-	-	-	73	80
											-	-	-	4.3	-	78.4	80
											-	-	-	-	1	74.3	80
-	-	-	4.3	1	79.7	80											
DBC1507S	575/3/60	2	7.4	50	2	0.5	1	2 speed Belt Drive High Static	5	5.2	-	-	-	-	-	23.9	30
											-	-	-	3.5	-	27.4	30
											-	-	-	-	1.2	25.1	30
											-	-	-	3.5	1.2	28.6	30
											-	-	-	-	-	24.5	30
											-	-	-	3.5	-	28.9	30
											-	-	-	-	1.2	26	30
											-	-	-	3.5	1.2	30.4	35
											-	-	-	-	-	42.6	45
											-	-	-	3.5	-	47	50
											-	-	-	-	1.2	44.1	45
											-	-	-	3.5	1.2	48.5	50
											-	-	-	-	-	60.6	70
											-	-	-	3.5	-	65	70
											-	-	-	-	1.2	62.1	70
-	-	-	3.5	1.2	66.5	70											
DBC1507V	575/3/60	2	7.4	50	2	0.5	1	2 speed Belt Drive Standard Static	3	3.5	-	-	-	-	-	22.2	25
											-	-	-	3.5	-	25.7	30
											-	-	-	-	1.2	23.4	25
											-	-	-	3.5	1.2	26.9	30
											-	-	-	-	-	22.4	25
											-	-	-	3.5	-	26.8	30
											-	-	-	-	1.2	23.9	25
											-	-	-	3.5	1.2	28.3	30
											-	-	-	-	-	40.5	45
											-	-	-	3.5	-	44.8	45
											-	-	-	-	1.2	42	45
											-	-	-	3.5	1.2	46.3	50
											-	-	-	-	-	58.5	60
											-	-	-	3.5	-	62.9	70
											-	-	-	-	1.2	60	70
-	-	-	3.5	1.2	64.4	70											

APPENDIX B ELECTRICAL DATA

ELECTRICAL DATA

Model Number	Electrical Rating	Compressor			Outdoor Fan Motor			Indoor Fan Motor			Optional Electric Heat			Optional Powered Convenience Outlet	Optional Power Exhaust	Power Supply	
		QTY	RLA	LRA	QTY	HP	FLA	Type	HP	FLA	Part #	KW*	FLA	FLA	FLA	MCA	MOP
DBH0903S	208/230/3/60	2	13.1	83.1	2	0.33	3.5	2 speed Belt Drive High Static	3	9.1	-	-	-	-	-	45.7/45.7	50/50
											-	-	-	9.6/8.7	-	55.3/54.4	60/60
											-	-	-	-	3.3/3.0	49.0/48.7	50/50
											-	-	-	9.6/8.7	3.3/3.0	58.6/57.4	60/60
											-	-	-	-	-	84.8/90.8	90/100
											EH*B-3M15	11.3/15.0	31.3/36.1	9.6/8.7	-	94.4/99.5	100/100
														-	3.3/3.0	88.1/93.8	90/100
														9.6/8.7	3.3/3.0	97.7/102	100/110
											EH*B-3M30	22.5/30.0	62.5/72.2	-	-	124/136	125/150
														9.6/8.7	-	133/145	150/150
														-	3.3/3.0	127/139	150/150
											EH*B-3M45	33.8/45.0	93.8/108	-	-	163/181	175/200
														9.6/8.7	-	173/190	175/200
														-	3.3/3.0	166/184	175/200
											-	-	-	9.6/8.7	3.3/3.0	176/193	200/200
DBH0903V	208/230/3/60	2	13.1	83.1	2	0.33	3.5	2 speed Belt Drive Standard Static	2	6	-	-	-	-	-	42.6/42.6	50/50
											-	-	-	9.6/8.7	-	52.2/51.3	60/60
											-	-	-	-	3.3/3.0	45.9/45.6	50/50
											-	-	-	9.6/8.7	3.3/3.0	55.5/54.3	60/60
											-	-	-	-	-	81.7/87.7	90/90
											EH*B-3M15	11.3/15.0	31.3/36.1	9.6/8.7	-	91.3/96.4	100/100
														-	3.3/3.0	85.0/90.7	90/100
														9.6/8.7	3.3/3.0	94.6/99.4	100/100
											EH*B-3M30	22.5/30.0	62.5/72.2	-	-	121/133	125/150
														9.6/8.7	-	130/141	150/150
														-	3.3/3.0	124/136	125/150
											EH*B-3M45	33.8/45.0	93.8/108	-	-	160/178	175/200
														9.6/8.7	-	169/187	175/200
														-	3.3/3.0	163/181	175/200
											-	-	-	9.6/8.7	3.3/3.0	173/190	175/200
DBH0904S	460/3/60	2	6.1	41	2	0.33	1.6	2 speed Belt Drive High Static	3	4.3	-	-	-	-	-	21.2	25
											-	-	-	4.3	-	25.5	30
											-	-	-	-	1	22.2	25
											-	-	-	4.3	1	26.5	30
											-	-	-	-	-	43.8	45
											EH*B-4M15	15	18	4.3	-	48.1	50
														-	1	44.8	45
														4.3	1	49.1	50
											EH*B-4M30	30	36.1	-	-	66.3	70
														4.3	-	70.6	80
														-	1	67.3	70
											EH*B-4M45	45	54.1	-	-	88.9	90
														4.3	-	93.2	100
														-	1	89.9	90
											-	-	-	4.3	1	94.2	100
DBH0904V	460/3/60	2	6.1	41	2	0.33	1.6	2 speed Belt Drive Standard Static	2	2.9	-	-	-	-	-	19.8	25
											-	-	-	4.3	-	24.1	30
											-	-	-	-	1	20.8	25
											-	-	-	4.3	1	25.1	30
											-	-	-	-	-	42.4	45
											EH*B-4M15	15	18	4.3	-	46.7	50
														-	1	43.4	45
														4.3	1	47.7	50
											EH*B-4M30	30	36.1	-	-	64.9	70
														4.3	-	69.2	70
														-	1	65.9	70
											EH*B-4M45	45	54.1	-	-	87.5	90
														4.3	-	91.8	100
														-	1	88.5	90
											-	-	-	4.3	1	92.8	100

APPENDIX B ELECTRICAL DATA

ELECTRICAL DATA

Model Number	Electrical Rating	Compressor			Outdoor Fan Motor			Indoor Fan Motor			Optional Electric Heat			Optional Powered Convenience Outlet	Optional Power Exhaust	Power Supply	
		QTY	RLA	LRA	QTY	HP	FLA	Type	HP	FLA	Part #	KW*	FLA	FLA	FLA	MCA	MOP
DBH0907S	575/3/60	2	4.4	33	2	0.33	3.5	2 speed Belt Drive High Static	3	3.5	-	-	-	-	-	20.3	25
											-	-	-	3.5	-	23.8	25
											-	-	-	-	1.2	21.5	25
											-	-	-	3.5	1.2	25	30
											-	-	-	-	-	38.3	40
											EH*B-7M15	15	14.4	3.5	-	41.8	45
														-	1.2	39.5	40
														3.5	1.2	43	45
											EH*B-7M30	30	28.9	-	-	56.4	60
														3.5	-	59.9	60
														-	1.2	57.6	60
											EH*B-7M45	45	43.3	3.5	-	61.1	70
														-	-	74.4	80
														3.5	-	77.9	80
											-	-	-	-	1.2	75.6	80
-	-	-	3.5	1.2	79.1	80											
DBH0907V	575/3/60	2	4.4	33	2	0.33	3.5	2 speed Belt Drive Standard Static	2	2.4	-	-	-	-	-	19.2	20
											-	-	-	3.5	-	22.7	25
											-	-	-	-	1.2	20.4	25
											-	-	-	3.5	1.2	23.9	25
											-	-	-	-	-	37.2	40
											EH*B-7M15	15	14.4	3.5	-	40.7	45
														-	1.2	38.4	40
														3.5	1.2	41.9	45
											EH*B-7M30	30	28.9	-	-	55.3	60
														3.5	-	58.8	60
														-	1.2	56.5	60
											EH*B-7M45	45	43.3	3.5	-	60	60
														-	-	73.3	80
														3.5	-	76.8	80
											-	-	-	-	1.2	74.5	80
-	-	-	3.5	1.2	78	80											
DBH1023S	208/230/3/60	2	14.5	98	2	0.33	3.5	2 speed Belt Drive High Static	3	9.1	-	-	-	-	-	48.7/48.7	60/60
											-	-	-	9.6/8.7	-	58.3/57.4	70/70
											-	-	-	-	3.3/3.0	52.0/51.7	60/60
											-	-	-	9.6/8.7	3.3/3.0	61.6/60.4	70/70
											-	-	-	-	-	87.8/93.8	90/100
											EH*B-3M15	11.3/15.0	31.3/36.1	9.6/8.7	-	97.4/103	100/110
														-	3.3/3.0	91.1/96.8	100/100
														9.6/8.7	3.3/3.0	101/106	110/110
											EH*B-3M30	22.5/30.0	62.5/72.2	-	-	127/139	150/150
														9.6/8.7	-	136/148	150/150
														-	3.3/3.0	130/142	150/150
											EH*B-3M45	33.8/45.0	93.8/108	9.6/8.7	-	140/151	150/175
														-	-	166/184	175/200
														9.6/8.7	-	176/193	200/200
											-	-	-	-	3.3/3.0	169/187	175/200
-	-	-	9.6/8.7	3.3/3.0	179/196	200/200											
DBH1023V	208/230/3/60	2	14.5	98	2	0.33	3.5	2 speed Belt Drive Standard Static	2	6	-	-	-	-	-	45.6/45.6	60/60
											-	-	-	9.6/8.7	-	55.2/54.3	60/60
											-	-	-	-	3.3/3.0	48.9/48.6	60/60
											-	-	-	9.6/8.7	3.3/3.0	58.5/57.3	60/60
											-	-	-	-	-	84.7/90.7	90/100
											EH*B-3M15	11.3/15.0	31.3/36.1	9.6/8.7	-	94.3/99.4	100/100
														-	3.3/3.0	88.0/93.7	90/100
														9.6/8.7	3.3/3.0	97.6/102	100/110
											EH*B-3M30	22.5/30.0	62.5/72.2	-	-	124/136	125/150
														9.6/8.7	-	133/145	150/150
														-	3.3/3.0	127/139	150/150
											EH*B-3M45	33.8/45.0	93.8/108	9.6/8.7	-	137/148	150/150
														-	-	163/181	175/200
														9.6/8.7	-	172/190	175/200
											-	-	-	-	3.3/3.0	166/184	175/200
-	-	-	9.6/8.7	3.3/3.0	176/193	200/200											

APPENDIX B ELECTRICAL DATA

ELECTRICAL DATA

Model Number	Electrical Rating	Compressor			Outdoor Fan Motor			Indoor Fan Motor			Optional Electric Heat			Optional Powered Convenience Outlet	Optional Power Exhaust	Power Supply	
		QTY	RLA	LRA	QTY	HP	FLA	Type	HP	FLA	Part #	KW*	FLA	FLA	FLA	MCA	MOP
DBH1024S	460/3/60	2	6.3	55	2	0.33	1.6	2 speed Belt Drive High Static	3	4.3	-	-	-	-	-	21.8	25
											-	-	-	4.3	-	26.1	30
											-	-	-	-	1	22.8	25
											-	-	-	4.3	1	27.1	30
											-	-	-	-	-	44.3	45
											EH*B-4M15	15	18	4.3	-	48.6	50
														-	1	45.3	50
														4.3	1	49.6	50
											EH*B-4M30	30	36.1	-	-	66.9	70
														4.3	-	71.2	80
														-	1	67.9	70
											EH*B-4M45	45	54.1	4.3	1	72.2	80
														-	-	89.4	90
														4.3	-	93.7	100
														-	1	90.4	100
-	-	-	4.3	1	94.7	100											
DBH1024V	460/3/60	2	6.3	55	2	0.33	1.6	2 speed Belt Drive Standard Static	2	2.9	-	-	-	-	-	20.4	25
											-	-	-	4.3	-	24.7	30
											-	-	-	-	1	21.4	25
											-	-	-	4.3	1	25.7	30
											-	-	-	-	-	42.9	45
											EH*B-4M15	15	18	4.3	-	47.2	50
														-	1	43.9	45
														4.3	1	48.2	50
											EH*B-4M30	30	36.1	-	-	65.5	70
														4.3	-	69.8	70
														-	1	66.5	70
											EH*B-4M45	45	54.1	4.3	1	70.8	80
														-	-	88	90
														4.3	-	92.3	100
														-	1	89	90
-	-	-	4.3	1	93.3	100											
DBH1027S	575/3/60	2	6	41	2	0.33	3.5	2 speed Belt Drive High Static	3	3.5	-	-	-	-	-	24.1	30
											-	-	-	3.5	-	27.6	30
											-	-	-	-	1.2	25.3	30
											-	-	-	3.5	1.2	28.8	30
											-	-	-	-	-	42.1	45
											EH*B-7M15	15	14.4	3.5	-	45.6	50
														-	1.2	43.3	45
														3.5	1.2	46.8	50
											EH*B-7M30	30	28.9	-	-	60.1	70
														3.5	-	63.6	70
														-	1.2	61.3	70
											EH*B-7M45	45	43.3	3.5	1.2	64.8	70
														-	-	78.2	80
														3.5	-	81.7	90
														-	1.2	79.4	80
-	-	-	3.5	1.2	82.9	90											
DBH1027V	575/3/60	2	6	41	2	0.33	3.5	2 speed Belt Drive Standard Static	2	2.4	-	-	-	-	-	23	25
											-	-	-	3.5	-	26.5	30
											-	-	-	-	1.2	24.2	25
											-	-	-	3.5	1.2	27.7	30
											-	-	-	-	-	41	45
											EH*B-7M15	15	14.4	3.5	-	44.5	45
														-	1.2	42.2	45
														3.5	1.2	45.7	50
											EH*B-7M30	30	28.9	-	-	59	60
														3.5	-	62.5	70
														-	1.2	60.2	70
											EH*B-7M45	45	43.3	3.5	1.2	63.7	70
														-	-	77.1	80
														3.5	-	80.6	90
														-	1.2	78.3	80
-	-	-	3.5	1.2	81.8	90											

APPENDIX B ELECTRICAL DATA

ELECTRICAL DATA

Model Number	Electrical Rating	Compressor			Outdoor Fan Motor			Indoor Fan Motor			Optional Electric Heat			Optional Powered Convenience Outlet	Optional Power Exhaust	Power Supply	
		QTY	RLA	LRA	QTY	HP	FLA	Type	HP	FLA	Part #	KW*	FLA	FLA	FLA	MCA	MOP
DBH1203S	208/230/3/60	2	15.9	110	2	0.33	3.5	2 speed Belt Drive High Static	3	9.1	-	-	-	-	-	51.9/51.9	60/60
											-	-	-	9.6/8.7	-	61.5/60.6	70/70
											-	-	-	-	3.3/3.0	55.2/54.9	60/60
											-	-	-	9.6/8.7	3.3/3.0	64.8/63.6	70/70
											-	-	-	-	-	91.0/97.0	100/100
											EH*B-3M16	11.3/15.0	31.3/36.1	9.6/8.7	-	101/106	110/110
														-	3.3/3.0	94.3/100.0	100/100
														9.6/8.7	3.3/3.0	104/109	110/110
											EH*B-3M31	22.5/30.0	62.5/72.2	-	-	130/142	150/150
														9.6/8.7	-	140/151	150/175
														-	3.3/3.0	133/145	150/150
											EH*B-3M46	33.8/45.0	93.8/108	9.6/8.7	-	143/154	150/175
														-	-	169/187	175/200
														-	3.3/3.0	179/196	200/200
											-	-	-	9.6/8.7	3.3/3.0	172/190	175/200
-	-	-	9.6/8.7	3.3/3.0	182/199	200/200											
DBH1203V	208/230/3/60	2	15.9	110	2	0.33	3.5	2 speed Belt Drive Standard Static	2	6	-	-	-	-	-	48.8/48.8	60/60
											-	-	-	9.6/8.7	-	58.4/57.5	70/70
											-	-	-	-	3.3/3.0	52.1/51.8	60/60
											-	-	-	9.6/8.7	3.3/3.0	61.7/60.5	70/70
											-	-	-	-	-	87.9/93.9	90/100
											EH*B-3M16	11.3/15.0	31.3/36.1	9.6/8.7	-	97.5/103	100/110
														-	3.3/3.0	91.2/96.9	100/100
														9.6/8.7	3.3/3.0	101/106	110/110
											EH*B-3M31	22.5/30.0	62.5/72.2	-	-	127/139	150/150
														9.6/8.7	-	137/148	150/150
														-	3.3/3.0	130/142	150/150
											EH*B-3M46	33.8/45.0	93.8/108	9.6/8.7	-	140/151	150/175
														-	-	166/184	175/200
														-	3.3/3.0	176/193	200/200
											-	-	-	9.6/8.7	3.3/3.0	169/187	175/200
-	-	-	9.6/8.7	3.3/3.0	179/196	200/200											
DBH1204S	460/3/60	2	7.1	52	2	0.33	1.6	2 speed Belt Drive High Static	3	4.3	-	-	-	-	-	23.4	30
											-	-	-	4.3	-	27.7	30
											-	-	-	-	1	24.4	30
											-	-	-	4.3	1	28.7	30
											-	-	-	-	-	45.9	50
											EH*B-4M16	15	18	4.3	-	50.2	60
														-	1	46.9	50
														4.3	1	51.2	60
											EH*B-4M31	30	36.1	-	-	68.5	70
														4.3	-	72.8	80
														-	1	69.5	70
											EH*B-4M46	45	54.1	4.3	1	73.8	80
														-	-	91	100
														-	-	95.3	100
											-	-	-	4.3	1	92	100
-	-	-	4.3	1	96.3	100											
DBH1204V	460/3/60	2	7.1	52	2	0.33	1.6	2 speed Belt Drive Standard Static	2	2.9	-	-	-	-	-	22	25
											-	-	-	4.3	-	26.3	30
											-	-	-	-	1	23	25
											-	-	-	4.3	1	27.3	30
											-	-	-	-	-	44.5	45
											EH*B-4M16	15	18	4.3	-	48.8	50
														-	1	45.5	50
														4.3	1	49.8	50
											EH*B-4M31	30	36.1	-	-	67.1	70
														4.3	-	71.4	80
														-	1	68.1	70
											EH*B-4M46	45	54.1	4.3	1	72.4	80
														-	-	89.6	90
														-	-	93.9	100
											-	-	-	4.3	1	90.6	100
-	-	-	4.3	1	94.9	100											

APPENDIX B ELECTRICAL DATA

Model Number	Electrical Rating	Compressor			Outdoor Fan Motor			Indoor Fan Motor			Optional Electric Heat			Optional Powered Convenience Outlet	Optional Power Exhaust	Power Supply	
		QTY	RLA	LRA	QTY	HP	FLA	Type	HP	FLA	Part #	KW*	FLA	FLA	FLA	MCA	MOP
DBH1207S	575/3/60	2	5.1	39.5	2	0.33	3.5	2 speed Belt Drive High Static	3	3.5	-	-	-	-	-	22	25
											-	-	-	3.5	-	25.5	30
											-	-	-	-	1.2	23.2	25
											-	-	-	3.5	1.2	26.7	30
											-	-	-	-	-	40.1	45
											EH*B-7M16	15	14.4	3.5	-	43.6	45
														-	1.2	41.3	45
														3.5	1.2	44.8	45
											EH*B-7M31	30	28.9	-	-	58.1	60
														3.5	-	61.6	70
														-	1.2	59.3	60
											EH*B-7M46	45	43.3	3.5	1.2	62.8	70
														-	-	76.2	80
														3.5	-	79.7	80
											-	-	-	-	1.2	77.4	80
-	-	-	3.5	1.2	80.9	90											
DBH1207V	575/3/60	2	5.1	39.5	2	0.33	3.5	2 speed Belt Drive Standard Static	2	2.4	-	-	-	-	-	20.9	25
											-	-	-	3.5	-	24.4	25
											-	-	-	-	1.2	22.1	25
											-	-	-	3.5	1.2	25.6	30
											-	-	-	-	-	39	40
											EH*B-7M16	15	14.4	3.5	-	42.5	45
														-	1.2	40.2	45
														3.5	1.2	43.7	45
											EH*B-7M31	30	28.9	-	-	57	60
														3.5	-	60.5	70
														-	1.2	58.2	60
											EH*B-7M46	45	43.3	3.5	1.2	61.7	70
														-	-	75.1	80
														3.5	-	78.6	80
											-	-	-	-	1.2	76.3	80
-	-	-	3.5	1.2	79.8	80											



APPENDIX B ELECTRICAL DATA

Model Number	Electrical Rating	Compressor			Outdoor Fan Motor			Indoor Fan Motor			Optional Electric Heat			Optional Powered Convenience	Optional Power Exhaust	Power Supply	
		QTY	RLA	LRA	QTY	HP	FLA	Type	HP	FLA	Part #	KW*	FLA	FLA	FLA	MCA	MOP
DBH1503S	208/230/3/60	2	22.4	149	2	0.5	2.7	2 speed Belt Drive High Static	5	14	-	-	-	-	-	69.9/69.9	90/90
											-	-	-	9.6/8.7	-	79.5/78.6	100/100
											-	-	-	-	-	73.2/72.9	90/90
											-	-	-	9.6/8.7	3.3/3.0	82.8/81.6	100/100
											-	-	-	-	-	109/115	110/125
											EH*B-3M16	11.3/15.0	31.3/36.1	9.6/8.7	-	119/124	125/125
														-	-	112/118	125/125
														9.6/8.7	3.3/3.0	122/127	125/150
											EH*B-3M31	22.5/30.0	62.5/72.2	-	-	148/160	150/175
														9.6/8.7	-	158/169	175/175
														-	3.3/3.0	151/163	175/175
														9.6/8.7	3.3/3.0	161/172	175/175
														-	-	187/205	200/225
														9.6/8.7	-	197/214	200/225
											EH*B-3M46	33.8/45.0	93.8/108	-	-	190/208	200/225
9.6/8.7	3.3/3.0	200/217	225/225														
-	-	-	-														
DBH1503V	208/230/3/60	2	22.4	149	2	0.5	2.7	2 speed Belt Drive Standard Static	3	9.1	-	-	-	-	-	65.0/65.0	80/80
											-	-	-	9.6/8.7	-	74.6/73.7	90/90
											-	-	-	-	-	68.3/68.0	80/80
											-	-	-	9.6/8.7	3.3/3.0	77.9/76.7	90/90
											-	-	-	-	-	104/110	110/125
											EH*B-3M16	11.3/15.0	31.3/36.1	9.6/8.7	-	114/119	125/125
														-	3.3/3.0	107/113	110/125
														9.6/8.7	3.3/3.0	117/122	125/125
											EH*B-3M31	22.5/30.0	62.5/72.2	-	-	143/155	150/175
														9.6/8.7	-	153/164	175/175
														-	3.3/3.0	146/158	150/175
														9.6/8.7	3.3/3.0	156/167	175/175
														-	-	182/200	200/225
														9.6/8.7	-	192/209	200/225
											EH*B-3M46	33.8/45.0	93.8/108	-	-	186/203	200/225
9.6/8.7	3.3/3.0	195/212	200/225														
-	-	-	-														
DBH1504S	460/3/60	2	10.6	75	2	0.5	1.4	2 speed Belt Drive High Static	5	6.6	-	-	-	-	-	33.2	40
											-	-	-	4.3	-	37.5	45
											-	-	-	-	-	34.2	40
											-	-	-	4.3	1	38.5	45
											-	-	-	-	-	55.7	60
											EH*B-4M16	15	18	4.3	-	60	70
														-	1	56.7	60
														4.3	1	61	70
											EH*B-4M31	30	36.1	-	-	78.3	80
														4.3	-	82.6	90
														-	1	79.3	80
														4.3	1	83.6	90
														-	-	101	110
														4.3	-	105	110
											EH*B-4M46	45	54.1	-	-	102	110
4.3	1	106	110														
-	-	-	-														

APPENDIX B ELECTRICAL DATA

Model Number	Electrical Rating	Compressor			Outdoor Fan Motor			Indoor Fan Motor			Optional Electric Heat			Optional Powered Convenience	Optional Power Exhaust	Power Supply		
		QTY	RLA	LRA	QTY	HP	FLA	Type	HP	FLA	Part #	KW*	FLA	FLA	FLA	MCA	MOP	
DBH1504V	460/3/60	2	10.6	75	2	0.5	1.4	2 speed Belt Drive Standard Static	3	4.3	-	-	-	-	-	30.9	40	
											-	-	-	4.3	-	-	35.2	45
											-	-	-	-	1	-	31.9	40
											-	-	-	4.3	1	-	36.2	45
											-	-	-	-	-	-	53.4	60
											EH*B-4M16	15	18	4.3	-	-	57.7	60
														-	1	-	54.4	60
														4.3	1	-	58.7	60
											EH*B-4M31	30	36.1	-	-	-	76	80
														4.3	-	-	80.3	90
														-	1	-	77	80
											EH*B-4M46	45	54.1	4.3	1	-	81.3	90
														-	-	-	98.6	100
														4.3	-	-	103	110
														-	1	-	99.6	100
4.3	1	-	104	110														
DBH1507S	575/3/60	2	7.7	54	2	0.5	1	2 speed Belt Drive High Static	5	5.2	-	-	-	-	-	24.5	30	
											-	-	-	3.5	-	-	28	35
											-	-	-	-	1.2	-	25.7	30
											-	-	-	3.5	1.2	-	29.2	35
											-	-	-	-	-	-	42.5	45
											EH*B-7M16	15	14.4	3.5	-	-	46	50
														-	1.2	-	43.7	45
														3.5	1.2	-	47.2	50
											EH*B-7M31	30	28.9	-	-	-	60.6	70
														3.5	-	-	64.1	70
														-	1.2	-	61.8	70
											EH*B-7M46	45	43.3	3.5	1.2	-	65.3	70
														-	-	-	78.6	80
														3.5	-	-	82.1	90
														-	1.2	-	79.8	80
3.5	1.2	-	83.3	90														
DBH1507V	575/3/60	2	7.7	54	2	0.5	1	2 speed Belt Drive Standard Static	3	3.5	-	-	-	-	-	22.8	30	
											-	-	-	3.5	-	-	26.3	30
											-	-	-	-	1.2	-	24	30
											-	-	-	3.5	1.2	-	27.5	30
											-	-	-	-	-	-	40.8	45
											EH*B-7M16	15	14.4	3.5	-	-	44.3	45
														-	1.2	-	42	45
														3.5	1.2	-	45.5	50
											EH*B-7M31	30	28.9	-	-	-	58.9	60
														3.5	-	-	62.4	70
														-	1.2	-	60.1	70
											EH*B-7M46	45	43.3	3.5	1.2	-	63.6	70
														-	-	-	76.9	80
														3.5	-	-	80.4	90
														-	1.2	-	78.1	80
3.5	1.2	-	81.6	90														

APPENDIX C UNIT DIMENSIONS

Models	Dimension "A" in.
DBC/DBH090-120	54-9/20
DBC150	54-9/20
DBH150	58-3/5

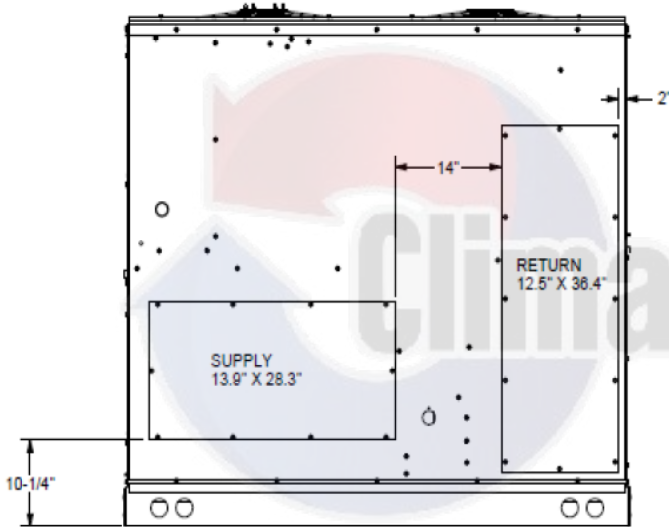
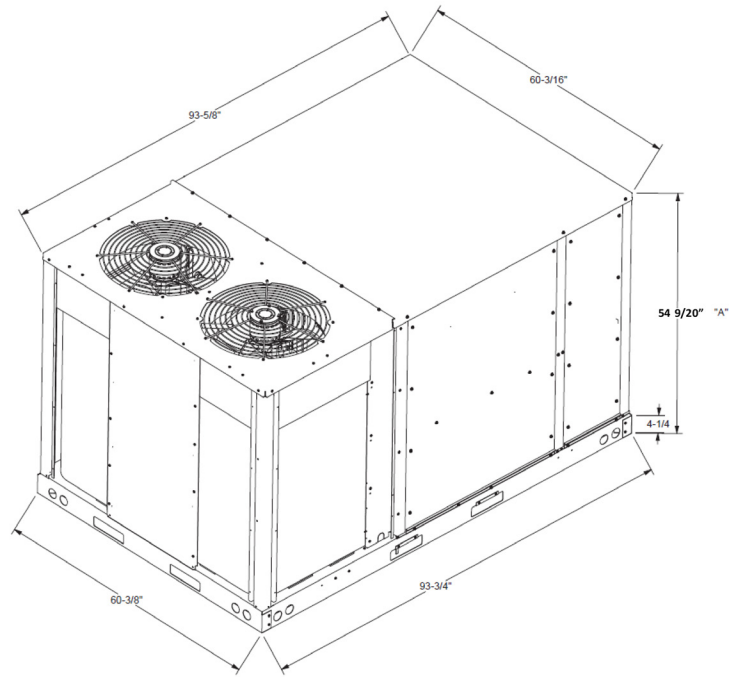

HORIZONTAL DISCHARGE

NOTE

For horizontal discharge, remove supply and return duct cover panels from the end of the unit. Save all washed screws. According to the model size, remove (6 or 8) factory supplied panel clips that are secured to the base pan, behind the filter access panel. With the insulated side of the panel facing up, attach the clips. Place the provided gasket material completely around the perimeter of the clip side on both panels. Place the assembled panels over the supply and return duct openings in the base pan and push down to snap panels into place. Ensure the panel is evenly seated on the flanges around the duct openings and the gasket is creating a good seal.

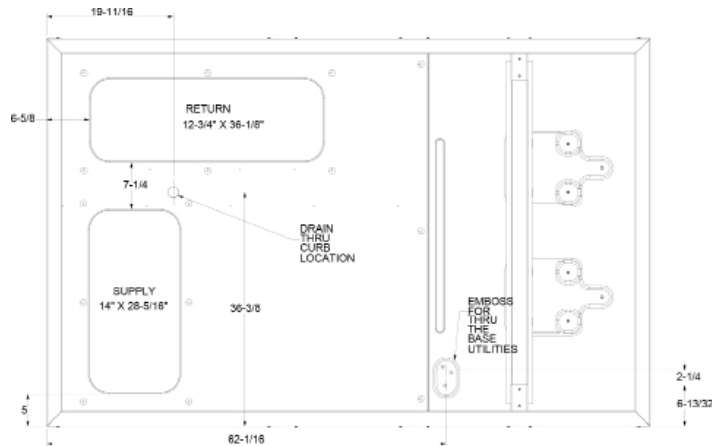

VERTICAL DISCHARGE (BOTTOM OF UNIT)

NOTE: REFER TO IOD-7082 INCLUDED IN THE LITERATURE PACK FOR INSTALLING HORIZONTAL DUCT COVERS.

APPENDIX D MIN-MAX AIRFLOW

	Model #	Min Airflow	EHB-3M15	EHB-3M16	EHB-3M30	EHB-3M31	EHB-3M45	EHB-3M46	EHSB-3M15	EHSB-3M16	EHSB-3M30	EHSB-3M31	EHSB-3M45	EHSB-3M46	EHB-4M15	EHB-4M16	EHB-4M30	EHB-4M31	EHB-4M45	EHB-4M46	EHSB-4M15	EHSB-4M16	EHSB-4M30	EHSB-4M31	EHSB-4M45	EHSB-4M46	EHB-7M15	EHB-7M16	EHB-7M30	EHB-7M31	EHB-7M45	EHB-7M46	EHSB-7M15	EHSB-7M16	EHSB-7M30	EHSB-7M31	EHSB-7M45	EHSB-7M46											
			BELC AC BELT DRIVE STANDARD STATIC	DBC0903V	2400	X		X		X		X		X		X																																	
DBC0904V	2400														X	X	X	X	X	X	X																												
DBC0907V	2400																													X	X	X	X	X	X	X	X	X	X	X	X	X	X	X	X	X			
DBC1023V	2750	X			X		X		X		X		X																																				
DBC1024V	2750														X	X	X	X	X	X	X	X																											
DBC1027V	2750																													X	X	X	X	X	X	X	X	X	X	X	X	X	X	X	X				
DBC1203V	3250			X		X		X		X		X		X																X	X	X	X	X	X	X	X	X	X	X	X	X	X	X	X	X			
DBC1204V	3250															X	X	X	X	X	X	X																											
DBC1207V	3250																													X	X	X	X	X	X	X	X	X	X	X	X	X	X	X	X	X			
DBC1503V	3750			X		X		X		X		X		X																X	X	X	X	X	X	X	X	X	X	X	X	X	X	X	X	X	X		
DBC1504V	3750															X	X	X	X	X	X	X																											
DBC1507V	3750																													X	X	X	X	X	X	X	X	X	X	X	X	X	X	X	X	X	X		
BELC AC BELT DRIVE HIGH STATIC	DBC0903S	2400	X		X		X		X		X		X																																				
	DBC0904S	2400													X	X	X	X	X	X	X																												
	DBC0907S	2400																												X	X	X	X	X	X	X	X	X	X	X	X	X	X	X	X	X	X	X	
	DBC1023S	2750	X		X		X		X		X		X																																				
	DBC1024S	2750													X	X	X	X	X	X	X	X																											
	DBC1027S	2750																												X	X	X	X	X	X	X	X	X	X	X	X	X	X	X	X	X	X		
	DBC1203S	3250		X		X		X		X		X		X																X	X	X	X	X	X	X	X	X	X	X	X	X	X	X	X	X	X	X	
	DBC1204S	3250														X	X	X	X	X	X	X																											
	DBC1207S	3250																												X	X	X	X	X	X	X	X	X	X	X	X	X	X	X	X	X	X	X	
	DBC1503S	3750		X		X		X		X		X		X																X	X	X	X	X	X	X	X	X	X	X	X	X	X	X	X	X	X	X	
	DBC1504S	3750														X	X	X	X	X	X	X																											
	DBC1507S	3750																												X	X	X	X	X	X	X	X	X	X	X	X	X	X	X	X	X	X	X	
BELC HP BELT DRIVE STANDARD STATIC	DBH0903V	2400	X		X		X		X		X		X																																				
	DBH0904V	2400													X	X	X	X	X	X	X																												
	DBH0907V	2400																												X	X	X	X	X	X	X	X	X	X	X	X	X	X	X	X	X	X	X	
	DBH1023V	2750	X		X		X		X		X		X																																				
	DBH1024V	2750													X	X	X	X	X	X	X	X																											
	DBH1027V	2750																												X	X	X	X	X	X	X	X	X	X	X	X	X	X	X	X	X	X		
	DBH1203V	3250		X		X		X		X		X		X																																			
	DBH1204V	3250														X	X	X	X	X	X	X																											
	DBH1207V	3250																												X	X	X	X	X	X	X	X	X	X	X	X	X	X	X	X	X	X	X	
	DBH1503V	3750		X		X		X		X		X		X																																			
	DBH1504V	3750														X	X	X	X	X	X	X																											
	DBH1507V	3750																													X	X	X	X	X	X	X	X	X	X	X	X	X	X	X	X	X	X	
BELC HP BELT DRIVE HIGH STATIC	DBH0903S	2400	X		X		X		X		X		X																																				
	DBH0904S	2400													X	X	X	X	X	X	X																												
	DBH0907S	2400																												X	X	X	X	X	X	X	X	X	X	X	X	X	X	X	X	X	X	X	
	DBH1023S	2750	X		X		X		X		X		X																																				
	DBH1024S	2750													X	X	X	X	X	X	X	X																											
	DBH1027S	2750																												X	X	X	X	X	X	X	X	X	X	X	X	X	X	X	X	X	X	X	
	DBH1203S	3250		X		X		X		X		X		X																																			
	DBH1204S	3250														X	X	X	X	X	X	X																											
	DBH1207S	3250																												X	X	X	X	X	X	X	X	X	X	X	X	X	X	X	X	X	X	X	
	DBH1503S	3750		X		X		X		X		X		X																X	X	X	X	X	X	X	X	X	X	X	X	X	X	X	X	X	X	X	X
	DBH1504S	3750														X	X	X	X	X	X	X																											
	DBH1507S	3750																												X	X	X	X	X	X	X	X	X	X	X	X	X	X	X	X	X	X	X	X

MODELS	COOLING MINIMUM SCFM	COOLING MAXIMUM SCFM
DBC/DBH090	2500	3375
DBC/DBH102	2850	3825
DBC/DBH120	3150	4500
DBC/DBH150	3750	5625

WIRING DIAGRAM

WARNING

HIGH VOLTAGE!
DISCONNECT ALL POWER BEFORE SERVICING OR INSTALLING THIS UNIT. MULTIPLE POWER SOURCES MAY BE PRESENT. FAILURE TO DO SO MAY CAUSE PROPERTY DAMAGE, PERSONAL INJURY OR DEATH.

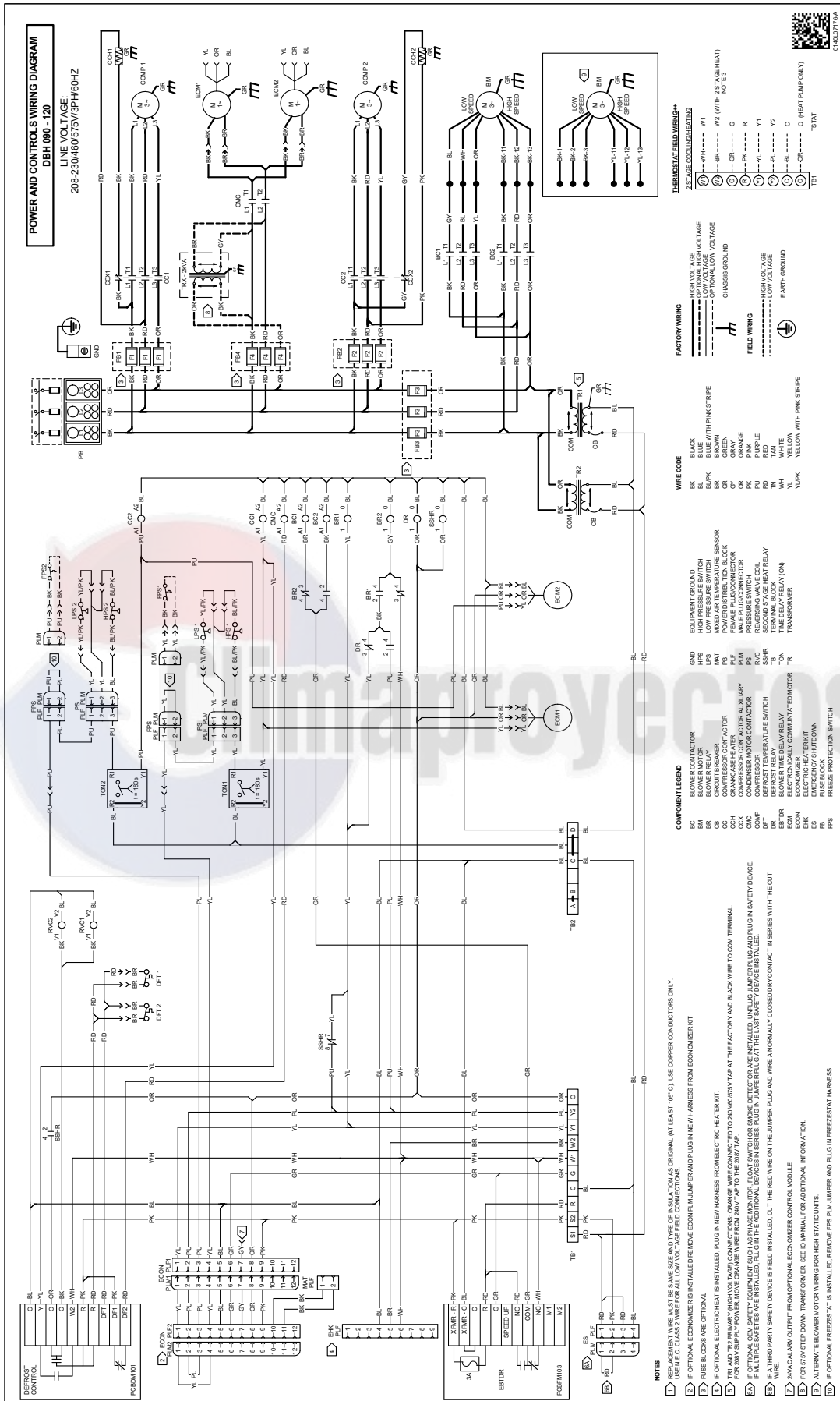

- POWER AND CONTROLS WIRING DIAGRAM**
DBH 880 - 120
LINE VOLTAGE:
208-230/460V/5/3PH/60HZ
- FACTORY WIRING**
HIGH VOLTAGE
LOW VOLTAGE
OPTIONAL LOW VOLTAGE
CHASSIS GROUND
- FIELD WIRING**
HIGH VOLTAGE
LOW VOLTAGE
OPTIONAL LOW VOLTAGE
EARTH GROUND
- WIRE CODE**
BLACK
BLUE
BROWN
GREEN
ORANGE
PINK
RED
TAN
YELLOW
YELLOW WITH PINK STRIPE
- COMPONENT LEGEND**
BC BLOWER MOTOR
BM BLOWER MOTOR
CB CIRCUIT BREAKER
CC COMPRESSOR CONTACTOR
CCX COMPRESSOR CONTACTOR AUXILIARY
CNC CONDENSER MOTOR CONTACTOR
DEF DEFROST RELAY
DFT DEFROST RELAY RELAY
ECON ECONOMIZER
ES EMERGENCY SHUTDOWN
FPS FREEZE PROTECTION SWITCH
- LEGEND**
GND EQUIPMENT GROUND
HPS HIGH PRESSURE SWITCH
MAT MIXED AIR TEMPERATURE SENSOR
PMS POWER DISTRIBUTION BLOCK
PLM MALE PLOUGH CONNECTOR
PS PRESSURE SWITCH
SSHR SECOND STAGE HEAT RELAY
TB TERMINAL BLOCK
TR TRANSFORMER
- NOTES**
1. WIRE INSULATION MUST BE SAME SIZE AND TYPE OF INSULATION AS ORIGINAL. AT LEAST 18 AWG. USE COPPER CONDUCTORS ONLY.
2. IF OPTIONAL ECONOMIZER IS INSTALLED REMOVE ECONOMIZER JUMPER AND PLUS IN NEW HARNESS FROM ECONOMIZER KIT.
3. FUSE BLOCKS ARE OPTIONAL.
4. IF OPTIONAL ELECTRIC HEAT IS INSTALLED, PLUG IN NEW HARNESS FROM ELECTRIC HEATER KIT.
5. TR1 AND TR2 PRIMARY POWER, ORANGE WIRE FROM 80V TAP TO THE 80V TAP.
6. IF OPTIONAL OEM SAFETY EQUIPMENT (SM) AS PHASE MONITOR, FLOAT SWITCH OR SMOKE DETECTOR ARE INSTALLED, UNPLUG JUMPER PLUG AND PLUG IN SAFETY DEVICE.
7. FOR 380V PRIMARY POWER, MOVE ORANGE WIRE FROM 80V TAP TO THE 380V TAP.
8. A THIRDPARTY SAFETY DEVICE IS FIELD INSTALLED. CUT THE RED WIRE ON THE JUMPER PLUG AND WIRE A NORMALLY CLOSED DRY CONTACT IN SERIES WITH THE CUT WIRE.
9. 3WV AC ARMATURE FROM OPTIONAL ECONOMIZER CONTROL MODULE.
10. FOR 975V STEP-DOWN TRANSFORMER, SEE TO MANUAL FOR ADDITIONAL INFORMATION.
11. ALTERNATE BLOWER MOTOR WIRING FOR HIGH STATIC UNITS.
12. IF OPTIONAL FREEZE STAT IS INSTALLED, REMOVE FPS JUMPER AND PLUG IN FREEZE/STAT HARNESS.
- THERMOSTAT FIELD WIRING**
2-STAGE COOLING/HEATING
W1
W2 (WITH 2 STAGE HEAT)
NOTE 3
- WIRE CODE**
BK BLACK
BL BLUE
BRN BROWN
GRN GREEN
ORNG ORANGE
PK PINK
RD RED
TAN TAN
YL YELLOW
YLPK YELLOW WITH PINK STRIPE
- COMPONENT LEGEND**
GND EQUIPMENT GROUND
HPS HIGH PRESSURE SWITCH
MAT MIXED AIR TEMPERATURE SENSOR
PMS POWER DISTRIBUTION BLOCK
PLM MALE PLOUGH CONNECTOR
PS PRESSURE SWITCH
SSHR SECOND STAGE HEAT RELAY
TB TERMINAL BLOCK
TR TRANSFORMER
- LEGEND**
GND EQUIPMENT GROUND
HPS HIGH PRESSURE SWITCH
MAT MIXED AIR TEMPERATURE SENSOR
PMS POWER DISTRIBUTION BLOCK
PLM MALE PLOUGH CONNECTOR
PS PRESSURE SWITCH
SSHR SECOND STAGE HEAT RELAY
TB TERMINAL BLOCK
TR TRANSFORMER

Wiring is subject to change. Always refer to the wiring diagram on the unit for the most up-to-date wiring.

WIRING DIAGRAM



WARNING
 HIGH VOLTAGE!
 DISCONNECT ALL POWER BEFORE SERVICING OR INSTALLING THIS UNIT. MULTIPLE POWER SOURCES MAY BE PRESENT. FAILURE TO DO SO MAY CAUSE PROPERTY DAMAGE, PERSONAL INJURY OR DEATH.

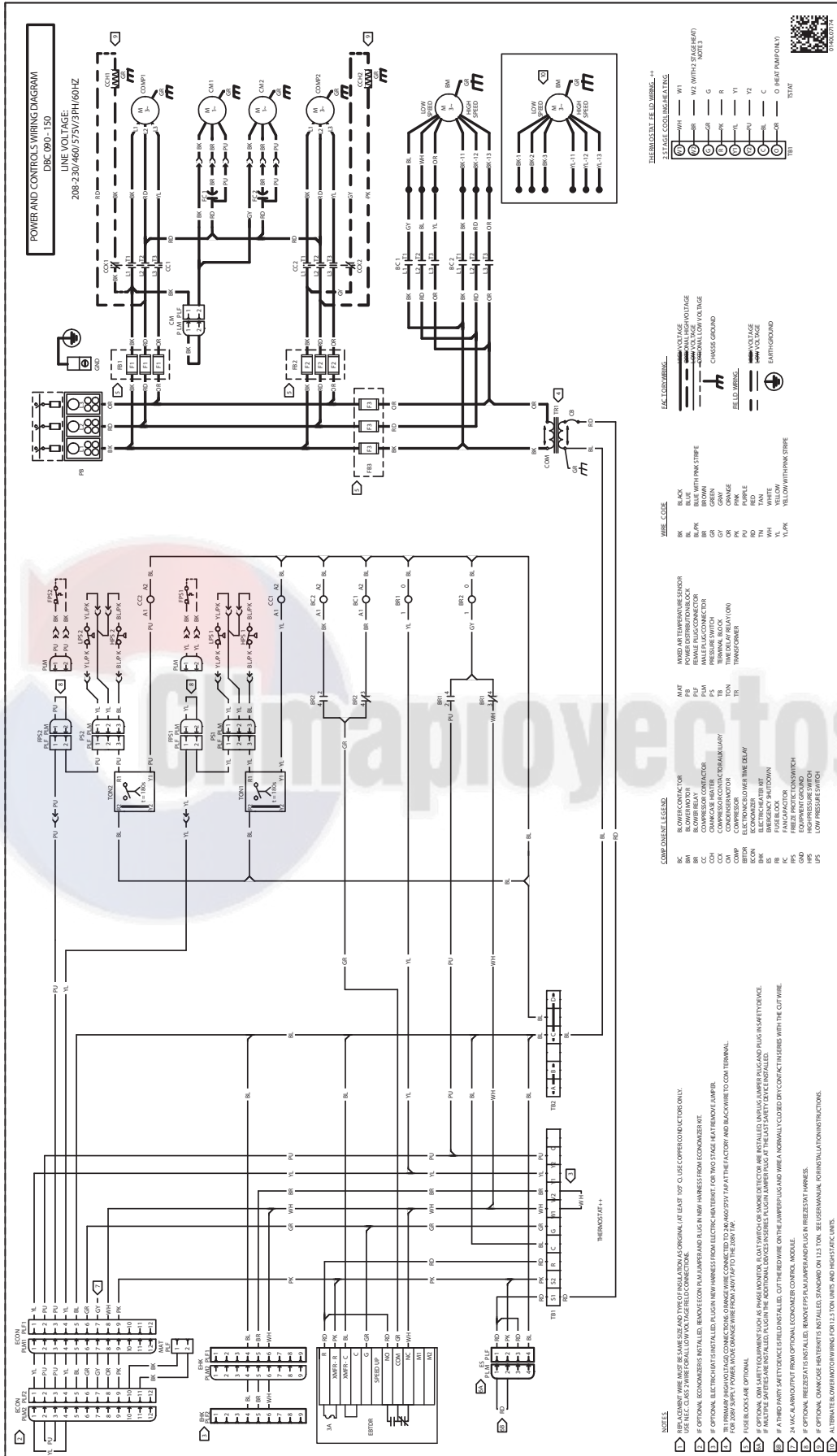

Wiring is subject to change. Always refer to the wiring diagram on the unit for the most up-to-date wiring.



Start-up Checklist

**Store in job file*

Date: _____ Location: _____
Model Number: _____
Serial Number: _____
Technician: _____ Unit #: _____

Pre Start-Up

(Check each item as completed)

- Verify all packaging material has been removed.
- Remove all shipping brackets per installation instructions.
- Verify the job site voltage agrees with the unit serial plate.
- Verify condensate connection is installed per installation instructions.
- Verify proper clearance around the unit for safety, service, maintenance and proper unit operation.
- Verify proper weatherproofing of all ductwork, roof curbs and electrical connections.
- Check that the flue screen is in place.
- Check gas piping for leaks.
- Verify gas pressure to the unit is within the range specified on the serial plate.
- Check to ensure that all fans, pulleys and wheels are secure.
- Check for proper belt tension and alignment per installation instructions.
- Check refrigerant piping for rubbing and leaks. *Repair if necessary.*
- Check unit wiring to ensure it is not in contact with refrigerant piping or sharp metal edges.
- Check all electrical connections and terminals. *Tighten as needed.*
- Verify that the crankcase heaters have been energized for 24 hours.
- Verify the scroll compressor(s) are rotating in the right direction.
- Verify all accessories are installed and operating correctly.
- Check filters and replace if necessary.
- Verify the installation of the thermostat.



Start-up Checklist

Start-Up
(Insert the values as each item is completed.)

ELECTRICAL

Supply Voltage	L1 - L2	_____	L2 - L3	_____	L3 - L1	_____
Circuit 1 Compressor Amps	L1	_____	L2	_____	L3	_____
Circuit 2 Compressor Amps	L1	_____	L2	_____	L3	_____
Blower Amps	L1	_____	L2	_____	L3	_____
Condenser Fan Amps	Fan 1	_____	Fan 2	_____	Fan 3	_____

BLOWER EXTERNAL STATIC PRESSURE

Return Air Static Pressure	_____	IN. W.C.
Supply Air Static Pressure	_____	IN. W.C.
Total External Static Pressure	_____	IN. W.C.
Blower Wheel RPM	_____	RPM

TEMPERATURES

Outdoor Air Temperature	_____	DB	_____	WB
Return Air Temperature	_____	DB	_____	WB
Cooling Supply Air Temperature	_____	DB	_____	WB
Heating Supply Air Temperature	_____	DB		

PRESSURES

Gas Inlet Pressure	_____	IN. W.C.		
Gas Manifold Pressure	_____	IN. W.C. (Low Fire)	_____	IN. W.C. (High Fire)
Suction Circuit 1	_____	PSIG	_____	°F
Superheat (Orifice System)			_____	°F
Suction Circuit 2	_____	PSIG	_____	°F
Superheat (Orifice System)			_____	°F
Discharge Circuit 1	_____	PSIG	_____	°F
Subcooling (TXV System)			_____	°F
Discharge Circuit 2	_____	PSIG	_____	°F
Subcooling (TXV System)			_____	°F

(HEAT PUMP ONLY)

Suction Circuit 1	_____	PSIG	_____	°F
Suction Circuit 2	_____	PSIG	_____	°F
Discharge Circuit 1	_____	PSIG	_____	°F
Discharge Circuit 2	_____	PSIG	_____	°F

THIS PAGE IS INTENTIONALLY LEFT BLANK



THIS PAGE IS INTENTIONALLY LEFT BLANK



CUSTOMER FEEDBACK

Daikin is very interested in all product comments.

Please fill out the feedback form on the following link:

<https://daikincomfort.com/contact-us>

You can also scan the QR code on the right to be directed to the feedback page.



Our continuing commitment to quality products may mean a change in specifications without notice.

©2020 **DAIKIN MANUFACTURING COMPANY, L.P.**

19001 Kermier Rd., Waller, TX 77484

www.daikincomfort.com