

Project Name: New Project

Tag Name: RCAE150HA22

Unit Information

Chiller Model..... RCAE150HA22	Chiller Series..... RCAE
Shipping Weight..... 8598.03 lb	Length 15.42 ft
Running Weight..... 9038.95 lb	Width 7.55 ft
Refrigerant Type..... R410A	Height..... 8.202 ft
Refrigerant Charge..... 83.8 83.8 lb	Sound 77.51 dBA
Controller MicroComputer Controller	Frequency..... 60 Hz
Voltage..... 460 V	Operating Range T1
Capacity Control Stage Control	Starter Type Direct OnLine

***Due to additional options and manufacturing deviation, the weight data in this report is for reference only, and the actual weight of the unit is subject to the actual product.**

Sound								
3m Noise			5m Noise			10m Noise		
73.02			70.08			65.39		
Octave sound pressure noise spectrum of 100% load								
63Hz	125Hz	250Hz	500Hz	1KHz	2KHz	4KHz	8KHz	Total
56.65	61.90	67.58	73.12	72.23	69.71	62.48	54.55	77.51

Sound Pressure (dB) measured in accordance with ANSI/AHRI Standard 575-2017(A-weighted)

TOLERANCES: The sound level of identical unit selections can vary due to manufacturing tolerance and test repeatability. Variations of ± 3 dBA on the Acoustic Data is possible. When Ultra Low Noise Option is selected, please consult the factory for specific sound level.

Barometric Information

Altitude..... 0 m Barometric Pressure..... 101.3 kPa

Performance Information

Cooling Condition

Ambient Temperature(DB) 95.0 °F	Leaving Fluid Temperature..... 44.00 °F
Entering Fluid Temperature 54.00 °F	Fluid Flow Rate..... 361.1 US gpm
Cooling Capacity..... 151.3 RT	Input Power 178.8 kW
COP.R..... 2.974 kW/kW	Water Pressure Drop..... 22.5 ftH2O
IPLV.IP..... 4.130 kW/kW	

Compressor Information

Type..... Fixed-frequency	Model scroll
Brand..... Danfoss	Number of Compressors 4
Oil Model..... P.O.E.160SZ	Oil Charge 13.4 13.4 L
Motor Configuration Power..... 55.00 kW	

Water Side Information

Heat Exchanger Type..... Shell-and-Tube Heat Exchanger Code DX

Project Name: New Project

Tag Name: RCAE150HA22

Fluid Type.....FreshWater	Concentration.....0.00%
Length..... 8.79 ft	Fouling Factor..... 0.000100 h*ft2*°F/Btu
Diameter.....14.84 inch	Connection Type..... Victaulic
Connection Size DN125	Water Volume..... 0.18 m3

Air Side Data

Heat Exchanger Type.....Fin-Coil	Air Flow 11771.56 cfm
Number of Fans.....8	Rows.....4
Power Input of Fan(Each)..... 2.400 kW	FLA of Fan (Each) 4.5 A

Electrical Information

Starting Amps 673.0 A	Cooling Full Load Amps..... 263.7 A
Maximum Operating Amps 344.0 A	

When Hydraulic Module Option is selected, the related current and operating power do not include the parameters of water pump of the hydraulic module, please consult the factory for details.

Recommended cable specifications and circuit breakers:

Cable specification (3P+PE)	1.05 times margin	Circuit breaker long delay Ir current range (When the cable ambient temperature is 35°C)
1*(4x2.5)	29	I ≤ 29
1*(4x4)	38	29 < I ≤ 38
1*(4x6)	49	38 < I ≤ 49
1*(4x10)	68	49 < I ≤ 68
1*(4x16)	91	68 < I ≤ 91
1*(3x25+16)	116	91 < I ≤ 116
1*(3x35+16)	144	116 < I ≤ 144
1*(3x50+25)	175	144 < I ≤ 175
1*(3x70+35)	224	175 < I ≤ 224
1*(3x95+50)	272	224 < I ≤ 272
1*(3x120+70)	316	272 < I ≤ 316
1*(3x150+95)	364	316 < I ≤ 364
1*(3x185+95)	416	364 < I ≤ 416
1*(3x240+120)	491	416 < I ≤ 491
1*(3x300+150)	567	491 < I ≤ 567
2*(3x95+50)	479	Reserved
2*(3x120+70)	556	Reserved
2*(3x150+95)	642	567 < I ≤ 642
2*(3x185+95)	733	642 < I ≤ 733
2*(3x240+120)	865	733 < I ≤ 865

Project Name: New Project

Tag Name: RCAE150HA22

2*(3x300+150)	999	865 < I ≤ 999
3*(3x120+70)	778	Reserved
3*(3x150+95)	897	Reserved
3*(3x185+95)	1025	999 < I ≤ 1025
3*(3x240+120)	1210	1025 < I ≤ 1210
3*(3x300+150)	1396	1210 < I ≤ 1396
4*(3x120+70)	999	Reserved
4*(3x150+95)	1152	Reserved
4*(3x185+95)	1317	Reserved
4*(3x240+120)	1554	1396 < I ≤ 1554
4*(3x300+150)	1794	1554 < I ≤ 1794

The recommended cable and circuit breaker should be selected according to the maximum operating current of the unit. Considering the three-phase voltage imbalance, it is recommended to configure the circuit breaker according to 1.1 times of the maximum operating current.

Note:

1. For low-voltage wiring, refer to GB/T 16895.6 Low-voltage Electrical Installations - Part 5-52: Selection and Erection of Electrical Equipment - Wiring Systems. If the customer has local laws and regulations, the local laws and regulations shall prevail. YJV-0.6/1KV routing conditions: ambient temperature: 35°C, tray bridge with holes, single layer contact laying, cable type: XLPE insulation & copper core. The number of cables for the same layer bridge shall be calculated according to the sum of the three phases of cables listed in the table.
2. If the cable insulation material, laying method, the number of cables on the same layer bridge is inconsistent with the recommendation (such as multi-layer bridge, pipe threading, high temperature), or the line voltage drop is > 2% due to distance, please select a new type according to the maximum operating current of the unit. When using other types of cables, pay attention to the size of wiring lugs to ensure that the electrical clearance meets the standards.
3. In the area where the temperature exceeds 45°C, check the circuit breaker model according to the high temperature capacity reduction curve of the selected brand circuit breaker to prevent misoperation or insufficient capacity.
4. When multiple cables are connected in parallel, each cable should be of equal length and laid in the same way. Conductors of the same material and section should be used.
5. The recommended cable is the minimum allowable wire diameter of the unit, and the cable is provided by the customer.

Option Information

Communication Protocol.....	Modbus	Anticorrosive Selection.....	Normal
Flow Switch.....	No	Insulation Thickness.....	20mm
Spring Isolator.....	No	Screen.....	Yes
Ultra Low Noise.....	No	WaterBox Pressure.....	1.0MPa

Certified in accordance with the AHRI Air-Cooled Water-Chilling Packages Certification Program, which is based on AHRI Standard 550/590 (I-P) and AHRI Standard 551/591 (SI). Certified units may be found in the AHRI Directory at www.ahridirectory.org

Project Name: New Project

Tag Name: RCAE150HA22

Calculation:IPLV.IP

Percentage of full load		100%	75%	50%	25%
Cooling Capacity	RT	151.2	113.4	75.64	37.82
Power Input	kW	178.8	108.3	60.06	28.47
Power Input per Capacity	kW/Ton	1.182	0.954	0.794	0.752
COP	kW/kW	2.974	3.683	4.428	4.671
Water Side Data					
EEFT	°F	54.00	51.47	48.98	46.49
ELFT	°F	44.00	44.00	44.00	44.00
Flow	US gpm	361.1	361.1	361.1	361.1
Air Side Data					
CEFT	°F	95.0	80.0	65.0	55.0
Weighting Factor		0.01	0.42	0.45	0.12
IPLV.IP	kW/Ton	0.8514 kW/Ton			
	kW/kW	4.130 kW/kW			

Project Name: New Project

Tag Name: RCAE150HA22

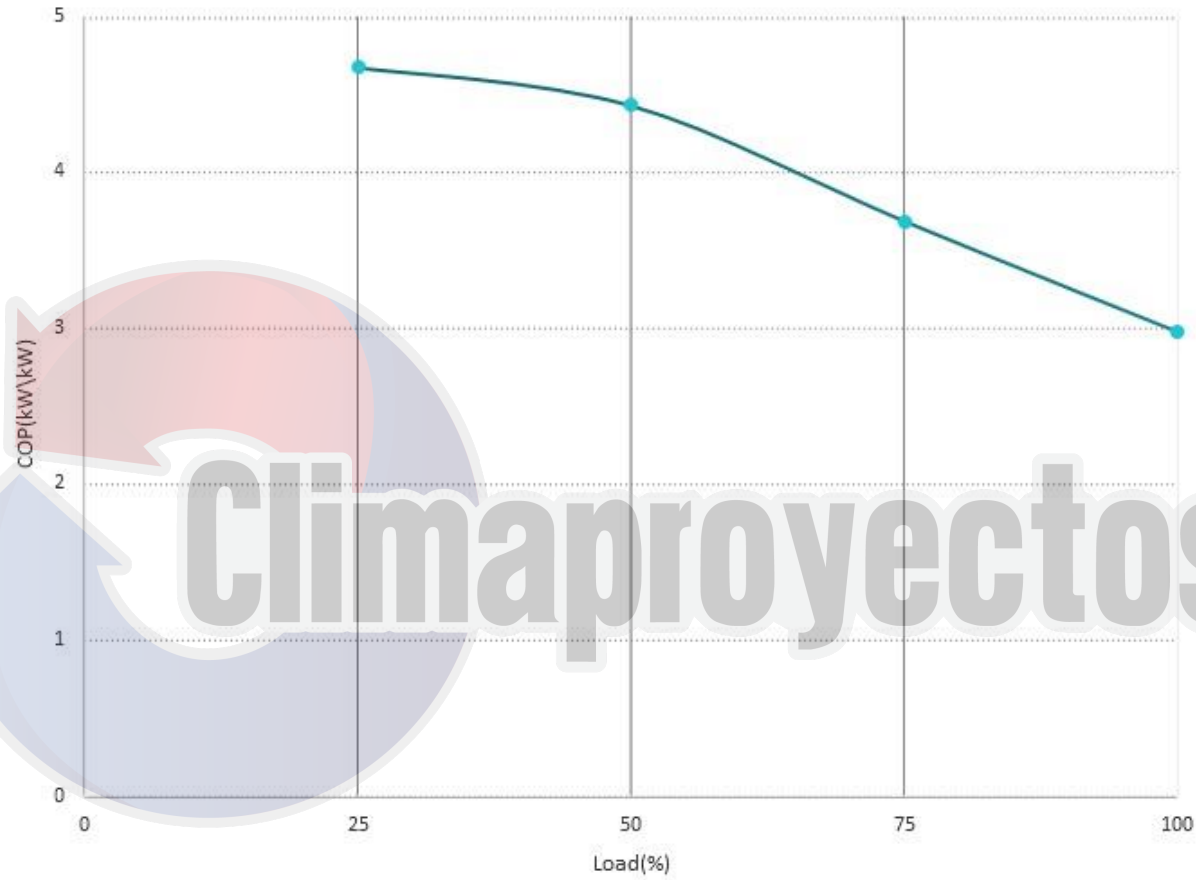

Project Name: New Project

Tag Name: RCAE150HA22

Calculation:Loadline1

Percentage of full load		100%	90%	80%	70%	60%	50%	40%	30%	20%	10%
Cooling Capacity	RT	151.2	136.1	121.0	105.8	90.76	75.64	60.51	45.38	NA	NA
Power Input	kW	178.8	161.5	144.2	127.2	110.4	93.64	75.11	56.28	NA	NA
Power Input per Capacity	kW/Ton	1.182	1.186	1.191	1.201	1.216	1.238	1.241	1.240	NA	NA
COP	kW/kW	2.974	2.963	2.950	2.926	2.890	2.840	2.833	2.835	NA	NA
Water Side Data											
EEFT	°F	53.96	52.97	51.97	50.97	49.98	48.98	47.99	46.99	NA	NA
ELFT	°F	44.00	44.00	44.00	44.00	44.00	44.00	44.00	44.00	44.00	44.00
Flow	US gpm	361.1	361.1	361.1	361.1	361.1	361.1	361.1	361.1	NA	NA
Air Side Data											
CEFT	°F	95.0	95.0	95.0	95.0	95.0	95.0	95.0	95.0	95.0	95.0
Weighting Factor		NA	NA	NA	NA	NA	NA	NA	NA	NA	NA
IPLV/NPLV/CPLV	kW/kW										

Project Name: New Project

Tag Name: RCAE150HA22

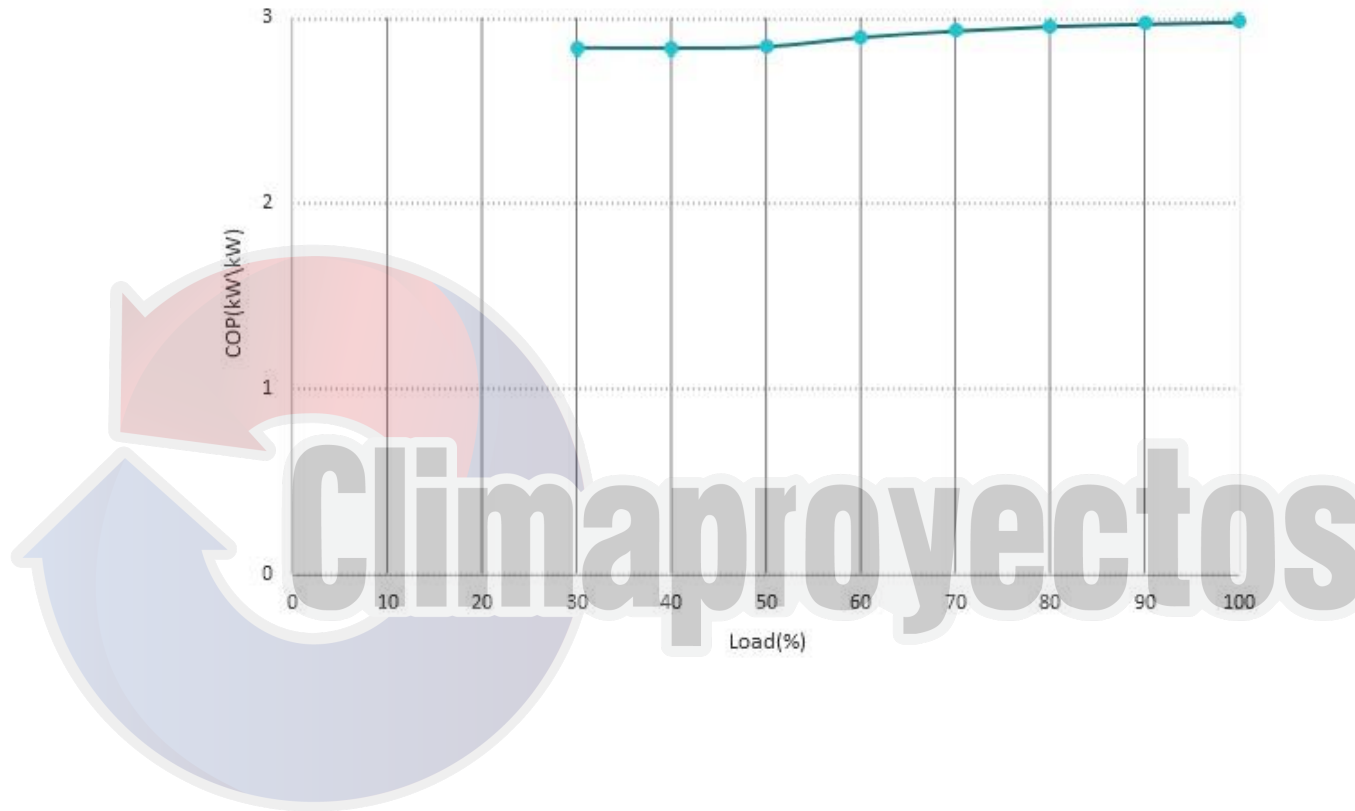

Project Name: New Project

Tag Name: RCAE150HA22

Fluid Pressure Drop Map

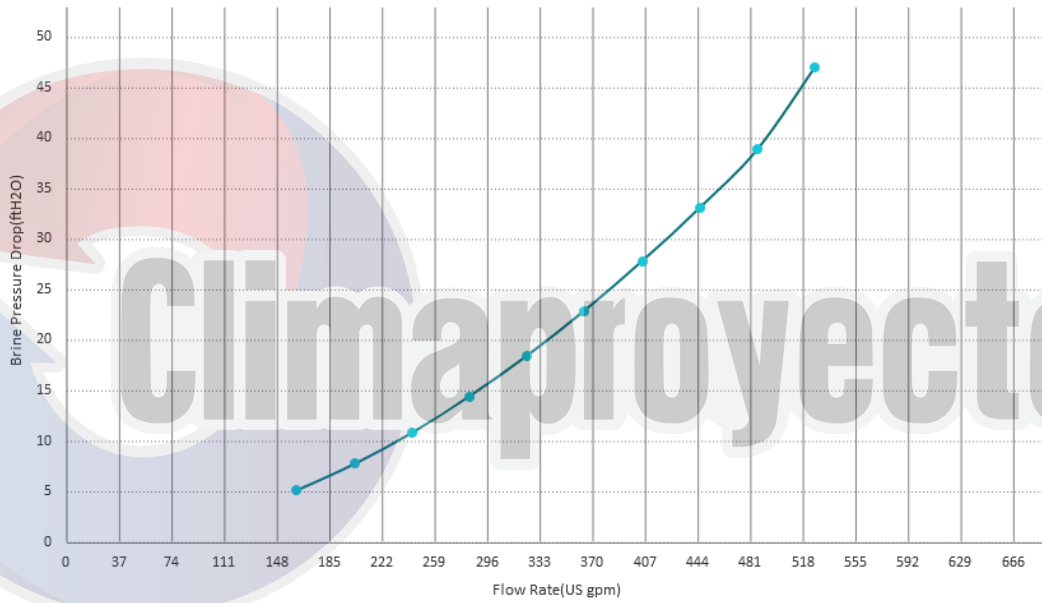

Project Name: New Project

Tag Name: RCAE150HA22

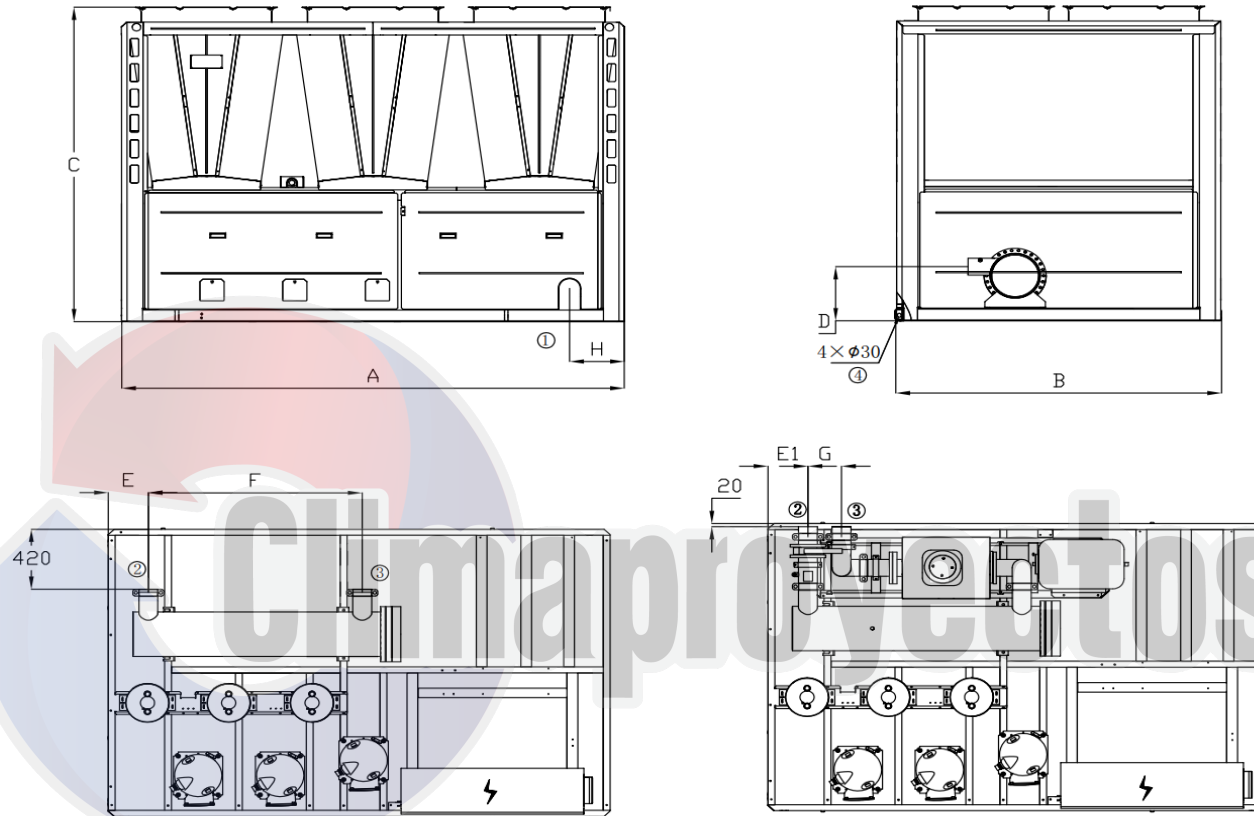

Location points of outline drawing (unit: mm)

A	B	C	D	E	F	G	H
4700	2300	2500	430	515	2390	825	1825

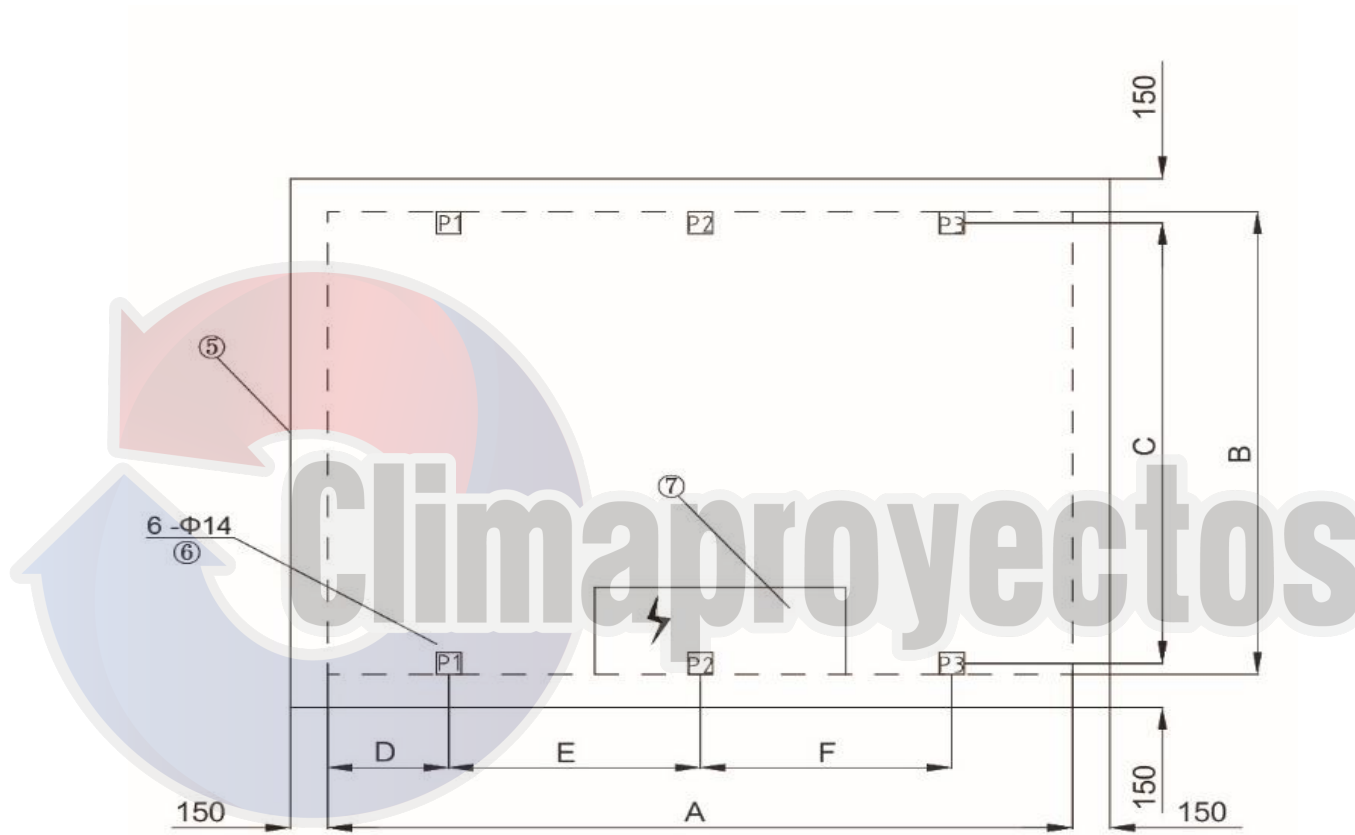

Location point of foundation map (unit: mm)					
A	B	C	D	E	F
4700	2300	2220	844	1412	1600

Project Name: New Project

Tag Name: RCAE150HA22

Load bearing position point of spring isolator		
P1	P2	P3
MHD-850	MHD-850	MHD-850

Explanation			
1	2	3	4
Power incoming line	Chilled water outlet-Victaulic connection	Chilled water inlet-Victaulic connection	Lifting point

Explanation		
5	6	7
Installation foundation	Spring isolator mounting hole	Electric control box