



Product Data

Commercial Split Systems Air Conditioning Condensing Units 6 to 25 Tons



38AUZ07,08,12,14 Shown

38AUZ, AUD 07-28 Single and Dual Circuit Condensing Units
with Puron® R-410A Refrigerant

These dependable outdoor air cooled condensing units match Carrier's indoor-air handlers to meet a wide selection of cooling solutions.

Carrier's air-cooled air conditioning split systems:

- Provide a logical solution for commercial needs
- Have rugged, dependable construction
- Available with single or dual refrigerant circuits
- Have cooling capability up to 125°F (52°C) ambient and down to 35°F (2°C) ambient standard

Constructed for long life

The 38AUZ single circuit and 38AUD dual circuit, air cooled condensing units are designed and built to last. The high efficient designed outdoor coil construction allows for a more efficient design in a smaller cabinet size that utilizes an overall reduction in refrigerant charge. Where conditions require, special coil coating coil protection option is available. Cabinets are constructed of pre-painted galvanized steel, delivering unparalleled protection from the environment. Inside and outside surfaces are protected to ensure long life, good looks, and reliable operation. Safety controls are used for enhanced system protection and reliability. Each unit utilizes the Comfort Alert™ diagnostic and troubleshooting control system. This protects the units operation and provides valuable diagnostic information when required.

Factory-installed options (FIOPs)

Certified and pre-engineered factory-installed options (FIOPs) allow units to be installed in less time, thereby reducing installed cost.

FIOPs include:

- low ambient controls which provide cooling operation down to -20°F (-29°C) ambient temperatures
- non-fused disconnect
- special coil coating coil protection
- louvered hail guard

Efficient operation

These air cooled condensing units will provide EERs up to 12.0 (tested in accordance with AHRI standard 340/360).

This high efficiency operation will help reduce overall operating cost and energy consumption.

Controls for performance dependability

The 38AU condensing units offer operating controls and components designed for performance dependability. The high efficiency hermetic scroll compressor is engineered for long life and durability. The compressors include vibration isolation for quiet operation. The high-pressure switch protects the entire refrigeration system from abnormally high operating pressures. A low-pressure switch protects the system from loss of charge. These units also include anti-short-cycling protection, which helps to protect the units against compressor failure.

All units include a crankcase heater to eliminate liquid slugging at start-up. Each unit comes standard with the Comfort Alert control system. This provides:

- System Go LED indicator
- Fault LED indicator
- Compressor fault LED indicator
- Phase loss protection
- Phase reversal protection
- Safety pressure indicator
- Anti-short cycle protection

Innovative Carrier 40RFA/RUA packaged air handlers are custom matched to 38AUZ/D condensing units.

Information on matching 40RFA/RUA DX packaged air handler follows for convenience. See separate product data for more details. The 40RFA/RUA Series has excellent fan performance, efficient direct-expansion (DX) coils, a unique combination of indoor-air quality features, and is easy to install. Its versatility and state-of-the-art features help to ensure economical performance of the split system both now and in the future.

Indoor-air quality (IAQ) features

The unique combination of features in the 40RFA/RUA air handlers ensures that clean, fresh, conditioned air is delivered to the occupied space.

Cooling coils prevent the build-up of humidity in the room, even during part-load conditions. Unit sizes 10 tons and above feature dual-circuit face-split coils.

Two-inch (51 mm) disposable filters remove dust and airborne particles from the occupied space.

Pitched drain pan can be adjusted for a right-hand or left-hand connection to provide positive drainage and prevent standing condensate.

Economizer accessory precisely controls the blend of outdoor air and room air to achieve comfort levels. When the outside air is suitable, outside air dampers can fully open to provide "free" cooling. Economizer is an Ultra Low Leak design that includes return and outside air damper leakage that meets California Title 24 section 140.4 requirements. Controller meets California Title 24 Section 120.2 Fault Detection and Diagnostic (FDD) requirements.

Economy

The 40RFA/RUA Series packaged air handlers have low initial costs, and they continue to save money by providing reduced installation expense and energy-efficient performance.

Quick installation is ensured by the multi-position design. Units can be installed in either the horizontal or vertical (upflow) configuration without modifications. All units have drain-pan connections on both sides, and pans can be pitched for right-hand or left hand operation with a simple adjustment.

Fan motors and contactors are pre-wired and TXVs are factory-installed on 40RFA/40RUAm models.

High-efficiency, precision balanced fans minimize air turbulence, surging, and unbalanced operation, thereby cutting operating expenses.

Table of contents

Features/Benefits	2
Model Number Nomenclature	3
AHRI Capacity Ratings	4
Physical Data	5
Base Unit Dimensions	9
38AU, 40RF/UA Options and Accessories	13
Typical Piping and Wiring Diagrams	16
Performance Data	30
Electrical Data	63
Application Data	66
Guide Specifications	67

Features/Benefits (cont)



Rugged dependability

The 40RFA/RUA series units are made to last. Die-formed galvanized steel panels ensure structural integrity under all operating conditions. Mechanically bonded coil fins provide improved heat transfer.

For 40RUA units, galvanized steel fan housings are securely mounted to a die-formed galvanized steel deck.

Rugged pillow-block bearings (40RUA sizes 14-30) are securely fastened to the solid steel fan shaft with split collets and clamp locking devices. 40RFA units (sizes 07-12) have spider-type bearings.

The accompanying air handling unit has thermal insulation containing an

immobilized anti-microbial agent to inhibit the growth of bacteria and fungi on the insulation.

Coil flexibility

Model 40RFA/RUA air handling units have galvanized steel casings; inlet and outlet connections are on the same end.

Chilled water coils have 1/2 in. (12.7 mm) diameter copper tubes mechanically bonded to aluminum sine-wave fins. All chilled water coils have non-ferrous headers.

Direct-expansion (DX) coils are designed for use with Puron® R-410A refrigerant and have copper tubes mechanically bonded to aluminum sine-wave fins.

Direct-expansion coils include matched, factory-installed thermostatic expansion valves (TXVs) with matching distributor nozzles.

Easier installation and service

The multipoise design and component layout ensures quick unit installation and operation. Units can be converted from horizontal to vertical operation by simply repositioning the unit. Drain pan connections are duplicated on both sides of the unit. The filters, motor, drive, TXVs, and coil connections are all easily accessed by removing a single side panel.

Model number nomenclature

1	2	3	4	5	6	7	8	9	10	11	12	13	14	15	16	17	18
3	8	A	U	D	T	1	2	A	0	A	6	-	0	A	0	A	0

Model Type

38AU = Carrier Condensing Unit
Puron® R-410A Refrigerant

Type of Coil

Z = Single Circuit, A/C Scroll Compressor
D = Dual Circuit, A/C Scroll Compressor

Refrigerant Options

A = None¹
B = Low Ambient¹
D = Single Circuit / 2-Stage²
E = Single Circuit / 2-Stage with Low Ambient²
M = Single Circuit / 2-Stage³
N = Single Circuit / 2-Stage with Low Ambient³
T = Dual Circuit / Three Cooling Stages⁴
U = Dual Circuit / Three Cooling Stages with Low Ambient⁴

Nominal Tonnage

07 = 6 Tons
08 = 7.5 Tons
12 = 10 Tons
14 = 12.5 Tons
16 = 15 Tons
25 = 20 Tons
28 = 25 Tons⁴

Not Used

A = Not Used

Not Used

0 = Not Used

NOTE(S):

- ¹ 38AUZ 16 and 25 units only.
- ² 38AUZ 07/08 models only.
- ³ 38AUZ 12/14 models only.
- ⁴ 38AUD models only.

Packaging

0 = Standard
1 = LTL

Electrical Options

A = None
C = Non-Fused Disconnect

Service Options

0 = None
1 = Un-powered Convenience Outlet
2 = Powered Convenience Outlet

Not Used

A = Place Holder

Base Unit Controls

0 = Electro-Mechanical Controls

Design Rev

- = Factory Specified

Voltage

1 = 575/3/60
5 = 208/230/3/60
6 = 460/3/60

Coil Options (RTPF)

A = Cu/Al
B = Precoat (Cu/Al)
C = E-Coat (Cu/Al)
E = Cu/Cu
M = Cu/Al with Louvered Hail Guard
N = Precoat (Cu/Al) with Louvered Hail Guard
P = E-Coat (Cu/Al) with Louvered Hail Guard
R = Cu/Cu with Louvered Hail Guard

AHRI Capacity Ratings^{a,b}

UNIT	COOLING STAGES	NOMINAL CAPACITY (tons)	NET COOLING CAPACITY (MBH)	TOTAL POWER (kW)	EER	IEER WITH 2-SPEED VFD
38AUZ(D,E)07/40RF07	2	6	70.0	5.8	12.0	15.5
38AUZ(D,E)08/40RF08	2	7.5	92.0	8.2	11.2	15.5
38AUZ(M,N)12/40RF12	2	10	117.0	10.4	11.2	15.5
38AUZ(M,N)14/40RU14	2	12.5	135.0	12.3	11.0	15.5
38AUZ(A,B)16/40RU16	2	15	184.0	16.4	11.2	14.3
38AUZ(A,B)25/40RU25	2	20	240.0	21.8	11.0	13.6
38AUD(T,U)12/40RF12	3	10	117.0	10.4	11.2	14.9
38AUD(T,U)14/40RU14	3	12.5	135.0	12.3	11.0	14.2
38AUD(T,U)16/40RU16	3	15	184.0	16.7	11.0	14.2
38AUD(T,U)25/40RU25	3	20	240.0	22.6	10.6	13.5
38AUD(T,U)28/40RU28	3	25	278.0	26.2	10.6	13.2

NOTE(S):

- a. Rated in accordance with AHRI Standard 340/360, as appropriate.
- b. Ratings are based on:
Cooling Standard: 80°F (27°C) db, 67°F (19°C) wb indoor air temp and 95°F (35°C) db outdoor air temp.

LEGEND

- AHRI — Air Conditioning, Heating, and Refrigeration
- ASHRAE — American Society of Heating, Refrigeration, and Air-Conditioning, Inc.
- EER — Energy Efficiency Ratio
- IEER — Integrated Energy Efficiency Ratio



Sound Power Levels, dB

UNIT	COOLING STAGES	A-WEIGHT OCTAVE OUTDOOR SOUND (dB) ^a								
		TOTAL	63	125	250	500	1000	2000	4000	8000
38AUZ07	2	84.6	63.1	68.9	73.4	79.5	80.2	76.4	72.0	64.9
38AUZ08	2	84.6	63.1	68.9	73.4	79.5	80.2	76.4	72.0	64.9
38AUZ12	2	83.2	60.4	65.8	77.1	76.8	77.1	75.8	70.2	64.7
38AUD12	3	83.8	62.9	69.6	74.4	77.9	79.3	76.1	70.7	61.1
38AUZ14	2	82.6	60.5	65.1	70.3	77.2	78.0	75.4	71.2	63.9
38AUD14	3	85.2	64.8	68.9	71.4	82.8	79.0	74.2	69.0	61.9
38AUZ16	2	84.2	60.1	69.7	72.8	78.7	79.5	76.3	72.9	67.8
38AUD16	3	82.8	55.5	64.8	73.6	77.2	78.2	74.8	70.7	64.3
38AUZ25	2	82.6	60.5	65.1	70.3	77.2	78.0	75.4	71.2	63.9
38AUD25	3	85.2	64.8	68.9	71.4	82.8	79.0	74.2	69.0	61.8
38AUD28	3	88.2	67.8	71.9	74.4	85.8	82.0	77.2	72.0	64.8

NOTE(S):

- a. Outdoor sound data is measured in accordance with AHRI standard 270-2008.

LEGEND

- dB — Decibel

38AUZ*07-12 Single Circuit Models – Physical Data

UNIT	38AUZ(D,E)07	38AUZ(D,E)08	38AUZ(M,N)12	38AUZ(M,N)14
NOMINAL CAPACITY (tons)	6	7.5	10	12.5
OPERATING WEIGHT (lb)	389	430	490	598
Refrigeration System				
No. Circuits / No. Comp. / Type	1 / 1 / Scroll	1 / 1 / Scroll	1 / 1 / Scroll	1 / 2 / Scroll
Refrigerant Type	Puron® R-410A	Puron R-410A	Puron R-410A	Puron R-410A
R-410A Shipping Charge A/B (lb)	9.0	9.0	9.0	9.0
System Charge w/ Fan Coil^a	14.0	19.0	22.0	34.2
Metering Device	TXV	TXV	TXV	TXV
High-Press. Trip / Reset (psig)	630 / 505	630 / 505	630 / 505	630 / 505
Low-Press. Trip / Reset (psig)	54 / 117	54 / 117	54 / 117	54 / 117
Compressor				
Oil Charge A/B (oz)	56	58	85	84
Speed (rpm, 60 Hz)	3500	3500	3500	3500
Condenser Coil				
Material	Al/Cu	Al/Cu	Al/Cu	Al/Cu
Coil type	RTPF	RTPF	RTPF	RTPF
Rows / FPI	2 / 17	2 / 17	2 / 17	3 / 17
Total Face Area (ft²)	17.5	23.0	25.1	31.8
Condenser Fan / Motor				
Qty / Motor Drive Type	2 / direct	2 / direct	2 / direct	2 / direct
Motor HP / RPM	1/4 / 1100	1/4 / 1100	1/4 / 1100	1/4 / 1100
Fan Diameter (in.)	22	22	22	22
Nominal Airflow (cfm)	6,000	6,000	6,000	6,000
Watts (total)	610	610	610	610
Piping Connections				
Qty / Suction (in. ODS)	1 / 1-1/8	1 / 1-1/8	1 / 1-3/8	1 / 1-3/8
Qty / Liquid (in. ODS)	1 / 3/8	1 / 1/2	1 / 1/2	1 / 5/8

NOTE(S):

- a. Approximate system charge with about 25 ft piping of sizes indicated with matched 40RFA or 40RUA.

38AUD*12-14 Two Circuit Models – Physical Data

UNIT	38AUD(T,U)12	38AUD(T,U)14
NOMINAL CAPACITY (tons)	10	12.5
OPERATING WEIGHT (lb)	516	654
Refrigeration System		
No. Circuits / No. Comp. / Type	2 / 2 / Scroll	2 / 2 / Scroll
Refrigerant Type	Puron R-410A	Puron R-410A
R-410A Shipping Charge A/B (lb)	9.0 / 9.0	9.0 / 9.0
System Charge w/ Fan Coil^a	11.9 / 13.1	16.2 / 16.1
Metering Device	TXV	TXV
High-Press. Trip / Reset (psig)	630 / 505	630 / 505
Low-Press. Trip / Reset (psig)	54 / 117	54 / 117
Compressor		
Oil Charge A/B (oz)	42 / 42	56 / 56
Speed (rpm, 60 Hz)	3500	3500
Condenser Coil		
Material	Al/Cu	Al/Cu
Coil type	RTPF	RTPF
Rows / FPI	2 / 17	3 / 17
Total Face Area (ft²)	31.8	31.8
Condenser Fan / Motor		
Qty / Motor Drive Type	2 / direct	2 / direct
Motor HP / RPM	1/4 / 1100	1/4 / 1100
Fan Diameter (in.)	22	22
Nominal Airflow (cfm)	6,000	6,000
Watts (total)	610	610
Piping Connections		
Qty / Suction (in. ODS)	2 / 1-1/8	2 / 1-3/8
Qty / Liquid (in. ODS)	2 / 3/8	2 / 1/2

NOTE(S):

- a. Approximate system charge with about 25 ft piping of sizes indicated with matched 40RFA or 40RUA.

38AUZ*16-25 Physical Data

UNIT	38AUZ(A,B)16	38AUZ(A,B)25
NOMINAL CAPACITY (tons)	15	20
OPERATING WEIGHT (lb)	731	978
Refrigeration System		
No. Circuits / No. Comp. / Type	1 / 2 / Scroll	1 / 2 / Scroll
Refrigerant Type	Puron R-410A	Puron R-410A
R-410A Shipping Charge A/B (lbs)	9.0	9.0
System Charge w/ Fan Coil^a	43.0	38.0
Metering Device	TXV	TXV
High-Press. Trip / Reset (psig)	630 / 505	630 / 505
Low-Press. Trip / Reset (psig)	54 / 117	54 / 117
Compressor		
Oil Charge A/B (oz)	60 / 60	110 / 110
Speed (rpm, 60 Hz)	3500	3500
Condenser Coil		
Material	Al/Cu	Al/Cu
Coil type	RTPF	RTPF
Rows / FPI	2 / 17	2 / 17
Total Face Area (ft²)	23.5 x 2	25.0 x 2
Condenser Fan / Motor		
Qty / Motor Drive Type	3 / direct	4 / direct
Motor HP / RPM	1/4 / 1100	1/4 / 1100
Fan Diameter (in.)	22	22
Nominal Airflow (cfm)	9,000	12,000
Watts (total)	970	1150
Piping Connections		
Qty / Suction (in. ODS)	1 / 1-3/8	1 / 1-5/8
Qty / Liquid (in. ODS)	1 / 5/8	1 / 5/8

NOTE(S):

- a. Approximate system charge with about 25 ft piping of sizes indicated with matched 40RUA.

38AUD*16-28 Physical Data

UNIT	38AUD(T,U)16	38AUD(T,U)25	38AUD(T,U)28
NOMINAL CAPACITY (tons)	15	20	25
OPERATING WEIGHT (lb)	731	978	978
Refrigeration System			
No. Circuits / No. Comp. / Type	2 / 2 / Scroll	2 / 2 / Scroll	2 / 2 / Scroll
Refrigerant Type	Puron R-410A	Puron R-410A	Puron R-410A
R-410A Shipping Charge A/B (lbs)	9.0 / 9.0	9.0 / 9.0	9.0 / 9.0
System Charge w/ Fan Coil^a	20.4 / 22.4	20.90 / 20.55	24.17 / 25.80
Metering Device	TXV	TXV	TXV
High-Press. Trip / Reset (psig)	630 / 505	630 / 505	630 / 505
Low-Press. Trip / Reset (psig)	54 / 117	54 / 117	54 / 117
Compressor			
Oil Charge A/B (oz)	60 / 60	110 / 110	110 / 110
Speed (rpm, 60 Hz)	3500 / 2900	3500 / 2900	3500 / 2900
Condenser Coil			
Material	Al/Cu	Al/Cu	Al/Cu
Coil type	RTPF	RTPF	RTPF
Rows / FPI	2 / 17	2 / 17	2 / 17
Total Face Area (ft²)	23.5 x 2	25.0 x 2	25.0 x 2
Condenser fan / motor			
Qty / Motor Drive Type	3 / direct	4 / direct	4 / direct
Motor HP / RPM	1/4 / 1100	1/4 / 1100	1/4 / 1100
Fan Diameter (in.)	22	22	22
Nominal Airflow (cfm)	9,000	12,000	12,000
Watts (total)	970	1150	1150
Piping Connections			
Qty / Suction (in. ODS)	2 / 1-3/8	2 / 1-3/8	2 / 1-3/8
Qty / Liquid (in. ODS)	2 / 1/2	2 / 1/2	2 / 1/2

NOTE(S):

- a. Approximate system charge with about 25 ft piping of sizes indicated with matched 40RUA.

38AUZ Piping Recommendations (Single-Circuit)

MODEL & NOMINAL CAPACITY	LINEAR LINE (FT)	0 - 24		25 - 49		50 - 74		75 - 99		100 - 124		125 - 149		150 - 174		175 - 200		
	EQUIV. LINE (FT)	0 - 37		38 - 74		75 - 112		113 - 149		150 - 187		188 - 224		225 - 262		263 - 300		
38AUZ_07 TC 68.5, SC 5.57°F	Liquid Line Size (in.)	3/8	3/8	1/2	1/2	5/8	1/2	5/8	1/2	5/8	1/2	5/8	1/2	5/8	1/2	5/8	1/2	5/8
	Liquid PD (F)	2.0	4.0	0.7	1.1	0.3	1.4	0.4	1.8	0.5	2.1	0.6	2.5	0.7	2.8	0.8		
	Max Lift (ft)	18	7	34	31	39	44	57	41	57	35	54	31	53	27	52		
	Max Lift PD (F)	3.5	4.6	3.5	3.5	3.5	5.0	5.0	5.0	5.0	4.9	5.0	5.0	5.0	5.0	5.0		
	Suction Line Size (in.)	7/8	7/8	1-1/8	7/8	1-1/8	7/8	1-1/8	7/8	1-1/8	1-1/8		1-1/8		1-1/8			
	Suction Ln PD (F)	0.9	1.8	0.5	2.7	0.8	3.6	1.0	4.5	1.3	1.6		1.8		2.1			
	Charge (lb)	10.8	11.8	13.7	15.2	18.5	16.9	21.3	18.7	24.2	21.4	27.1	23.4	30.0	25.3	32.8		
	#/TR	1.90	2.07	2.41	2.67	3.25	2.97	3.74	3.28	4.25	3.8	4.75	4.1	5.26	4.4	5.75		
38AUZ(D,E) 08 TC 92.0, SC 11.3°F	Liquid Line Size (in.)	1/2	1/2	5/8	1/2	5/8	1/2	5/8	1/2	5/8	1/2	5/8	1/2	5/8	1/2	5/8	1/2	5/8
	Liquid PD (F)	0.6	1.3	0.3	1.9	0.5	2.5	0.7	3.2	0.9	3.8	1.0	4.4	1.2	5.1	1.4		
	Max Lift (ft)	25	50	50	75	75	100	100	97	97	90	90	82	121	74	119		
	Max Lift PD (F)	2.7	5.4	4.5	8.1	6.7	10.8	9.0	11.2	8.9	11.2	8.5	11.2	11.2	11.2	11.2		
	Suction Line Size (in.)	7/8	7/8	1-1/8	7/8	1-1/8	1-1/8		1-1/8	1-3/8	1-1/8	1-3/8	1-1/8	1-3/8	1-1/8	1-3/8	1-1/8	1-3/8
	Suction Ln PD (F)	1.5	3.1	0.8	4.6	1.2	1.6		2.1	0.7	2.5	0.8	2.9	1.0	3.3	1.1		
	Charge (lb)	15.6	19.0	19.7	20.8	24.1	23.1	26.9	25.1	30.7	26.0	32.8	27.0	34.8	27.9	37.1		
	#/TR	2.08	2.53	2.63	2.77	3.21	3.08	3.59	3.35	4.09	3.47	4.37	3.60	4.64	3.73	4.95		
38AUZ_12 TC 113.1, SC 7.1°F	Liquid Line Size (in.)	1/2	1/2	5/8	1/2	5/8	1/2	5/8	1/2	5/8	1/2	5/8	5/8		5/8			
	Liquid PD (F)	0.9	1.9	0.5	2.8	0.8	3.8	1.0	4.7	1.3	5.7	1.6	1.8		2.1			
	Max Lift (ft)	25	40	50	28	54	34	68	22	65	11	63	59		55			
	Max Lift PD (F)	2.9	5.0	4.5	5.0	5.0	6.5	6.4	6.5	6.4	6.5	6.5	6.4		6.4			
	Suction Line Size (in.)	7/8	1-3/8	1-3/8	1-1/8	1-3/8	1-1/8	1-3/8	1-1/8	1-3/8	1-1/8	1-3/8	1-1/8	1-3/8	1-1/8	1-3/8	1-1/8	1-3/8
	Suction Ln PD (F)	2.4	1.2	1.2	1.8	0.6	2.4	0.9	3.1	1.1	3.7	1.3	4.3	1.5	4.9	1.7		
	Charge (lb)	15.7	18.0	20.0	19.8	23.1	21.6	26.1	23.6	29.2	25.5	32.3	34.1	35.3	36.9	38.4		
	#/TR	1.67	1.89	2.09	2.10	2.45	2.29	2.77	2.50	3.10	2.71	3.43	3.62	3.75	3.92	4.08		
38AUZ_14 TC 146.1, SC 3.9°F	Liquid Line Size (in.)	5/8	5/8	3/4	5/8	3/4	5/8	3/4	5/8	3/4	5/8	3/4	5/8	3/4	5/8	3/4	5/8	3/4
	Liquid PD (F)	0.4	0.8	0.4	1.2	0.6	1.6	0.8	2.0	1.1	2.4	1.1	2.8	1.5	1.7	0.6		
	Max Lift (ft)	23	16	23	10	18	28	38	21	36	14	35	9	30	25	43		
	Max Lift PD (F)	1.8	1.84	1.84	1.8	1.8	3.3	3.3	3.3	3.3	3.3	3.3	3.3	3.3	3.3	3.3		
	Suction Line Size (in.)	1-5/8	1-5/8	1-5/8	1-1/8	1-3/8	1-3/8		1-3/8	1-5/8	1-3/8	1-5/8	1-3/8	1-5/8	1-3/8	1-5/8	1-3/8	1-5/8
	Suction Ln PD (F) (Cap Red)	0.1	0.2	0.2	3.3 (-2.3%)	1.2	1.6		2.0	0.8	2.4 (-0.7%)	1.0	2.8 (-1.4%)	1.2	3.2 (-2.1%)	1.3		
	Charge (lb)	35.1	38.4	40.9	37.6	41.8	41.1	46.1	44.2	51.6	47.3	56.1	50.3	60.6	63.4	76.9		
	#/TR	3.10	3.99	3.62	3.09	3.44	3.38	3.79	3.64	4.24	3.89	4.61	4.14	4.98	5.21	6.32		
38AUZ_16 TC 185.7, SC 18.4°F	Liquid Line Size (in.)	5/8	5/8		5/8		5/8		5/8		5/8		5/8	3/4	5/8	3/4		
	Liquid PD (F)	0.7	1.3		2.0		2.7		3.4		4.0		4.7	2.5	5.4	2.8		
	Max Lift (ft)	25	50		75		100		125		150		153	175	145	175		
	Max Lift PD (F)	2.8	5.65		8.5		11.3		14.1		16.9		17.9	17.5	17.9	17.9		
	Suction Line Size (in.)	1-3/8	1-3/8		1-3/8		1-3/8		1-3/8	1-5/8	1-3/8	1-5/8	1-3/8	1-5/8	1-3/8	1-5/8	1-3/8	1-5/8
	Suction Ln PD (F) (Cap Red)	1.4	1.0		1.5		2.0		2.5 (-0.9%)	1.1	3 (-1.8%)	1.3	3.5 (-2.7%)	1.5	4 (-3.6%)	1.7		
	Charge (lb)	35.1	38.1	41.2	44.2	47.3	48.4	50.4	51.7	53.4	63.7	63.7	56.5	68.3	68.3			
	#/TR	2.9	3.11	3.36	3.61	3.86	3.95	4.11	4.22	4.36	5.20	4.61	5.57					
38AUZ_25 TC 233.3, SC 13.0°F	Liquid Line Size (in.)	5/8	5/8		5/8		5/8		5/8	3/4	5/8	3/4	5/8	3/4	5/8	3/4	5/8	3/4
	Liquid PD (F)	1.1	2.1		3.2		4.3		5.4	2.8	6.4	3.3	7.5	3.9	8.6	4.4		
	Max Lift (ft)	25	50		93		98		85	116	71	108	59	102	46	95		
	Max Lift PD (F)	3.2	6.4		9.6		12.5		12.5	12.5	12.4	12.5	12.5	12.5	12.5	12.5		
	Suction Line Size (in.)	1-3/8	1-3/8		1-3/8	1-5/8	1-3/8	1-5/8	1-3/8	1-5/8	1-5/8	2-1/8	1-5/8	2-1/8	1-5/8	2-1/8	1-5/8	2-1/8
	Suction Ln PD (F) (Cap Red)	0.8	1.6		2.4 (-0.8%)	1.0	3.3 (-2.2%)	1.4	4 (-3.6%)	1.7	2.0	0.4	2.4 (-0.7%)	0.5	2.7 (-1.2%)	0.6		
	Charge (lb)	31.1	34.1	37.2	37.9	40.2	41.1	43.3	50.7	47.7	58.5	51.0	63.6	54.3	68.7			
	#/TR	2.52	2.77	3.02	3.07	3.26	3.34	3.51	4.11	3.87	4.75	4.13	5.16	4.40	5.57			

LEGEND

- #/TR — Charge to unit capacity ratio, lbs per ton (at 45°F SST, 95°F ODA)
- Cap Red — Capacity reduction caused by suction line pressure drop GT 2°F
- Liquid PD (F) — Liquid line pressure drop, saturated temperature, °F
- Max Lift — Maximum liquid lift (Indoor unit ABOVE outdoor unit only), at maximum permitted pressure drop.
- Max Lift PD (F) — Pressure drop including Maximum liquid lift value
- SC — Sub-cooling, °F (at liquid line valve)
- TC — Total Capacity, MBH (at 45°F saturated suction, 95°F outdoor air temp)

38AUD Piping Recommendations (Dual-Circuit)^a

MODEL & NOMINAL CAPACITY	LINEAR LINE (FT)	0 - 24	25 - 49	50 - 74	75 - 99	100 - 124	125 - 149	150 - 174	175 - 200							
	EQUIV. LINE (FT)	0 - 37	38 - 74	75 - 112	113 - 149	150 - 187	188 - 224	225 - 262	263 - 300							
38AUD_12 TC 55.9 Each, SC 12.7°F	Liquid Line Size (in.)	3/8	3/8	3/8	3/8	1/2	3/8	1/2	3/8	1/2	5/8	1/2	5/8			
	Liquid PD (F)	1.4	2.7	5.5	5.5	0.9	6.9	1.1	8.2	1.4	1.6	0.5	1.8	0.5		
	Max Lift (ft)	25	50	75	82	100	66	125	49	133	130	144	128	144		
	Max Lift PD (F)	3.4	6.8	10.2	12.1	9.0	12.1	11.2	12.1	12.1	12.1	12.1	12.1	12.1		
	Suction Line Size (in.)	3/4	7/8	7/8	7/8	1-1/8	7/8	1-1/8	1-1/8	1-1/8	1-1/8	1-1/8	1-1/8	1-1/8		
	Suction Ln PD (F) (Cap Red)	1.4	1.2	1.8	2.5 (-0.8%)	0.8	3.1 (-1.9%)	0.9	1.1	1.3	1.5					
	Charge (lb)	9.0	10.0	11.0	12.1	15.7	13.1	17.7	14.9	19.6	21.5	28.2	23.5	31.0		
#/TR	0.73	0.81	0.89	0.97	1.27	1.05	1.42	1.20	1.58	1.74	2.27	1.89	2.50			
38AUD_14 TC 69.8 Each, SC 14.2°F	Liquid Line Size (in.)	3/8	3/8	3/8	3/8	1/2	3/8	1/2	1/2	1/2	5/8	1/2	5/8			
	Liquid PD (F)	2.1	4.1	6.2	8.2	1.5	10.3	1.8	2.2	2.6	0.7	2.9	0.8			
	Max Lift (ft)	25	50	75	69	155	42	125	145	140	163	135	162			
	Max Lift PD (F)	4.0	8.1	12.1	13.6	9.4	13.6	11.7	13.6	13.6	13.6	13.6	13.6			
	Suction Line Size (in.)	1-3/8	1-3/8	7/8	1-1/8	1-1/8	1-1/8	1-1/8	1-1/8	1-1/8	1-1/8	1-1/8	1-1/8			
	Suction Ln PD (F) (Cap Red)	0.3	0.6	2.9 (-1.5%)	0.8	1.1	1.4	1.6	1.9	2.2 (-0.3%)	0.7					
	Charge (lb)	16.5	17.9	19.0	19.5	20.6	23.7	21.8	25.7	27.6	29.5	36.2	31.5	39.0		
#/TR	1.44	1.56	1.52	1.56	1.65	1.90	1.74	2.05	2.21	2.36	2.89	2.52	3.12			
38AUD_16 TC 92.9 Each, SC 15.1°F	Liquid Line size	3/8	3/8	3/8	1/2	1/2	1/2	1/2	5/8	1/2	5/8	1/2	5/8			
	Liquid PD (F)	3.4	6.9	10.3	1.9	2.6	3.2	3.9	1.0	4.5	1.2	5.1	1.4			
	Max Lift	25	50	32	75	144	125	127	150	121	159	112	157			
	Max Lift PD (F)	5.5	11.1	13.0	8.2	10.9	13.7	14.5	13.6	14.5	14.5	14.5	14.5			
	Suction Line size	1-3/8	1-3/8	1-1/8	1-1/8	1-1/8	1-1/8	1-3/8	1-1/8	1-3/8	1-1/8	1-3/8	1-1/8			
	Suction Ln PD(F) (Cap Red)	0.5	1.0	1.2	1.6	2 (-0.1%)	0.7	2.5 (-0.8%)	0.8	2.9 (-1.5%)	1.0	3.3 (-2.2%)	1.1			
	Charge	22.6	23.9	19.5	21.8	23.7	25.7	26.6	27.6	34.4	29.5	37.4	31.5	40.5		
#/TR	1.42	1.50	1.55	1.73	1.89	2.04	2.11	2.19	2.73	2.35	2.97	2.50	3.22			
38AUD_25 TC 121.2 Each, SC 10.6°F	Liquid Line size	3/8	1/2	1/2	5/8	1/2	5/8	1/2	5/8	5/8	5/8	5/8	3/4			
	Liquid PD (F)	5.6	2.2	3.3	0.9	4.3	1.2	5.4	1.5	6.5	1.8	2.1	2.4	1.3		
	Max Lift	25	50	64	75	70	108	55	104	42	100	97	92	107		
	Max Lift PD (F)	7.7	6.3	8.5	7.1	10.0	9.4	9.9	10.0	10.0	10.0	10.0	9.9	10.0		
	Suction Line size	1-1/8	1-1/8	1-1/8	1-3/8	1-1/8	1-3/8	1-1/8	1-3/8	1-3/8	1-3/8	1-3/8	1-3/8			
	Suction Line PD(F) (Cap Red)	0.7	1.3	2.0	0.7	2.7 (-1.2%)	1.0	3.4 (-2.4%)	1.2	1.4	1.7	1.9	1.9			
	Charge	15.2	17.9	19.8	23.2	21.7	26.2	23.7	29.3	26.7	32.4	35.4	38.5	48.5		
#/TR	1.20	1.41	1.56	1.83	1.72	2.07	1.87	2.31	2.11	2.56	2.80	3.04	3.83			
38AUD_28 TC 281.9 Each, SC 13.9°F	Liquid Line size	1/2	1/2	5/8	5/8	3/4	5/8	3/4	5/8	3/4	7/8	3/4	7/8	3/4	7/8	
	Liquid PD (F)	4.2	8.5	3.0	4.6	2.4	6.1	3.2	7.7	4.0	4.8	1.5	5.6	1.8	6.4	2.1
	Max Lift	25	14	50	48	75	42	79	23	69	59	99	49	96	39	93
	Max Lift PD (F)	6.3	9.6	7.1	8.4	8.4	9.5	9.5	9.5	9.5	9.5	9.5	9.5	9.5	9.5	9.5
	Suction Line size	1-1/8	1-3/8	1-5/8	1-3/8	1-5/8	1-5/8	1-5/8	1-5/8	1-5/8	1-5/8	1-5/8	1-5/8	2-1/8		
	Suction Line PD(F) (Cap Red)	4.2 (-4.0%)	2.8 (-1.6%)	1.2	4.3 (-4.2%)	1.8	2.4	3.0 (-1.9%)	3.6 (-2.9%)	4.2 (-4.0%)	1.9					
	Charge	25.8	28.1	30.4	33.7	39.1	39.2	44.2	43.1	49.3	54.4	63.3	59.5	69.8	64.6	76.4
#/TR	1.10	1.20	1.30	1.44	1.67	1.67	1.88	1.83	2.10	2.32	2.69	2.53	2.97	2.75	3.25	

NOTE(S):

a. 38AUD units require TWO sets of refrigeration piping.

LEGEND

- #/TR — Charge to unit capacity ratio, lbs per ton (at 45°F SST, 95°F ODA)
- Cap Red — Capacity reduction caused by suction line pressure drop GT 2°F
- Liquid PD (F) — Liquid line pressure drop, saturated temperature, °F
- Max Lift — Maximum liquid lift (Indoor unit ABOVE outdoor unit only), at maximum permitted pressure drop.
- Max Lift PD (F) — Pressure drop including Maximum liquid lift value
- SC — Sub-cooling, °F (at liquid line valve)
- TC — Total Capacity, MBH (at 45°F saturated suction, 95°F outdoor air temp)

Base unit dimensions



38AUD/Z 07-14 Base Unit Dimensions

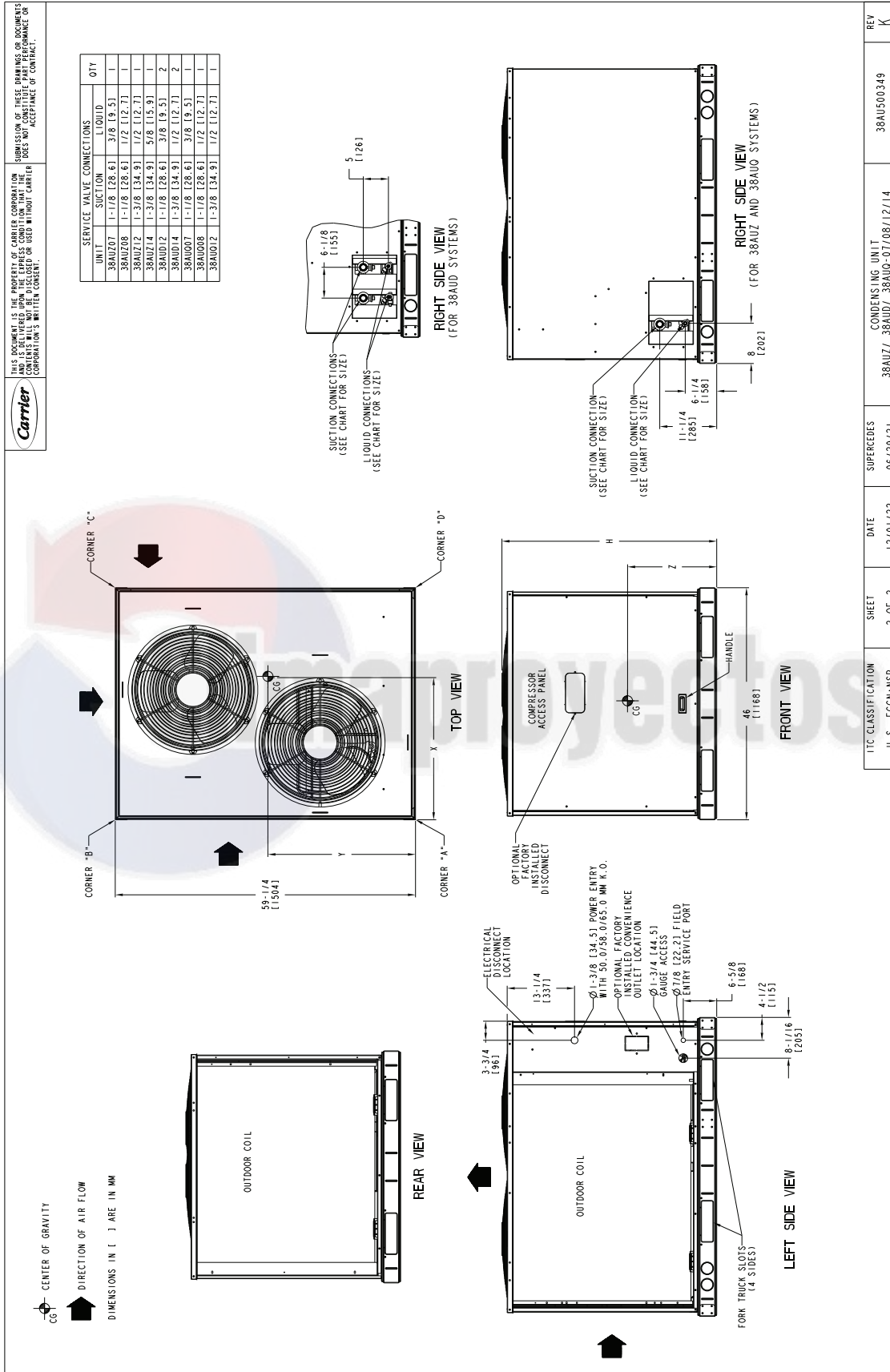

Base unit dimensions (cont)



38AU 07-14 Corner Weights

UNIT	STD. UNIT WT.		CORNER A		CORNER B		CORNER C		CORNER D		CENTER OF GRAVITY ^a			UNIT HEIGHT ^a
	lb	kg	lb	kg	lb	kg	lb	kg	lb	kg	X	Y	Z	H
38AUZ*07	389	176	141	64	96	44	62	28	91	41	18 [457.2]	24 [609.6]	21 [533.4]	42 3/8 [1076.0]
38AUZ*08	430	195	142	64	96	44	76	34	111	50	18 [457.2]	24 [609.6]	21 [533.4]	42 3/8 [1076.0]
38AUZ*12	490	222	177	80	120	54	78	35	114	52	18 [457.2]	24 [609.6]	24 [609.6]	50 3/8 [1279.2]
38AUZ*14	598	271	195	88	142	64	110	50	151	68	20 [508.0]	25 [635.0]	24 [609.6]	50 3/8 [1279.2]
38AUD*12	516	234	185	84	117	53	83	38	131	59	19 [482.6]	23 [584.2]	24 [609.6]	50 3/8 [1279.2]
38AUD*14	654	297	214	97	155	70	120	54	165	75	20 [508.0]	25 [635.0]	24 [609.6]	50 3/8 [1279.2]

NOTE(S):

a. Dimensions are in inches [mm].



Base unit dimensions (cont)



38AUD/Z 16 Base Unit Dimensions

UNIT	ELECTRICAL CHARACTERISTICS		STD. UNIT WT. LBS.	CORNER A LBS.	CORNER B LBS.	CORNER C LBS.	CORNER D LBS.	CENTER OF GRAVITY			UNIT HEIGHT				
	208/230-3-60-460-3-60-575-3-60	231/107/172/18						332/237/107/172/18	135/61/186/84	38/196/5.2/1	19/148/2.6/1	17/143/1.8/1	50-21/8	112/9-2/1	
38AUZ16 (RTPF)	208/230-3-60-460-3-60-575-3-60	231/107/172/18	332	135	61	186	84	38	196	5.2	19	143	1.8	50-21/8	112/9-2/1
38AUD16 (RTPF)	208/230-3-60-460-3-60-575-3-60	231/107/172/18	332	135	61	186	84	38	196	5.2	19	143	1.8	50-21/8	112/9-2/1



THIS DOCUMENT IS THE PROPERTY OF CARRIER CORPORATION AND IS DELIVERED UNDER THE EXPRESS CONDITION THAT THE USER SHALL NOT REPRODUCE, COPIY, OR TRANSMIT IN ANY MANNER WITHOUT CARRIER'S WRITTEN CONSENT.

- NOTES:
- MINIMUM CLEARANCE (LOCAL CODES OR JURISDICTION MAY PREVAIL):
 - A. COMBUSTIBLE SURFACES: 0 INCHES.
 - B. OUTDOOR COILS FOR PROPER AIR FLOW: 36 INCHES ONE SIDE, 12 INCHES THE OTHER. THE SIDE GETTING THE GREATER CLEARANCE IS OPTIONAL.
 - C. OVERHEAD: 60 INCHES. TO ASSURE PROPER OUTDOOR FAN OPERATION.
 - D. BETWEEN UNITS: CONTROL BOX SIDE, 42 INCHES PER NEC. SIDE, 36 INCHES PER NEC. CONCRETE WALLS AND OTHER GROUNDED SURFACES; CONTROL BOX SIDE, 42 INCHES PER NEC. WITH EXCEPTION OF THE CLEARANCE FOR THE OUTDOOR COIL AS STATED IN NOTE 1B. A REMOVABLE FENCE OR BARRIER REQUIRE NO CLEARANCE.
 - E. FROM WOOD OR CLASS A, B OR C ROOF COVERING MATERIAL.

UNIT	SERVICE VALVE CONNECTIONS		QTY
	SUCTION	LIQUID	
38AUZ16	1-3/8 (34.9)	5/8 (12.7)	1 EA
38AUD16	1-3/8 (34.9)	1/2 (12.7)	2 EA

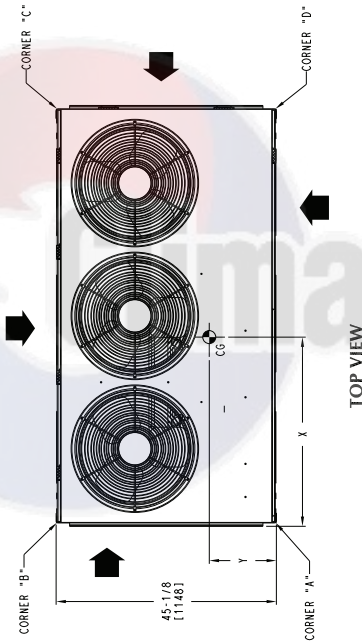
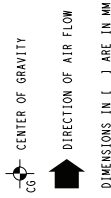

TOP VIEW

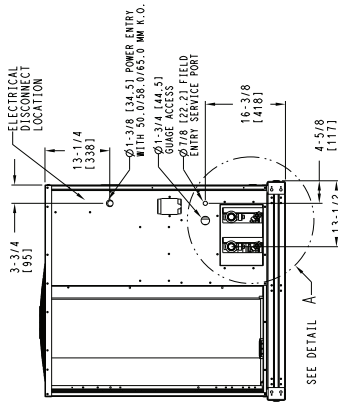

LEFT SIDE VIEW FOR 38AUD SYSTEMS

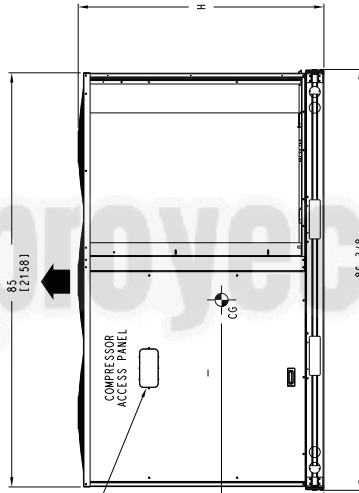

FRONT VIEW

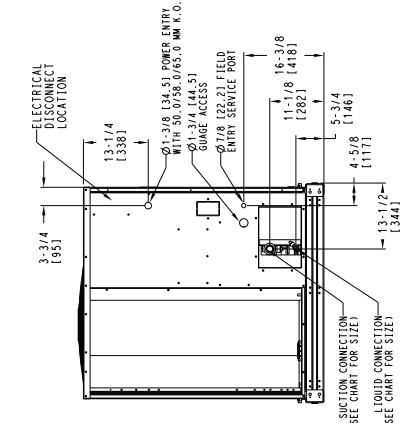

LEFT SIDE VIEW

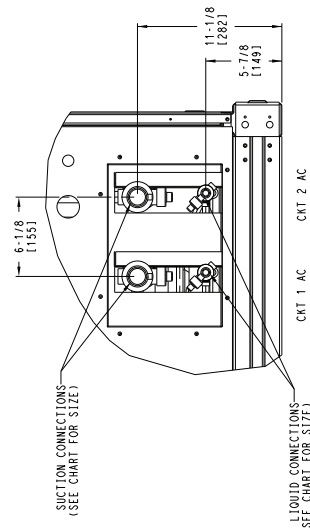

REV	DESCRIPTION	DATE	SHEET	TIC CLASSIFICATION	SUPERCEDES	DATE	U.S. ECCN/NSR
H	38AUZ, 38AUD CONDENSING UNIT	02/07/22	1 OF 1	U.S. ECCN: NSR	05/08/19	02/07/22	
	38AU500503						

Base unit dimensions (cont)



38AUZ 25 / 38AUD 25-28 Base Unit Dimensions

THIS DRAWING IS THE PROPERTY OF CARRIER CORPORATION AND IS DELIVERED UNDER THE EXPRESS CONDITION THAT THE CONTENTS WILL NOT BE DISCLOSED OR USED WITHOUT CARRIER CORPORATION'S WRITTEN CONSENT.

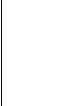

SUBMISSION OF THESE DRAWINGS OR DOCUMENTS DOES NOT CONSTITUTE AN ACCEPTANCE OF CONTRACT.

- NOTES:
- MINIMUM CLEARANCE (LOCAL CODES OR JURISDICTION MAY PREVAIL) TO COMBUSTIBLE SURFACES: 0 INCHES OUTDOOR COIL FOR PROPER AIR FLOW: 36 INCHES ONE SIDE, 12 INCHES THE OTHER, THE SIDE GETTING THE GREATER CLEARANCE IS OPTIONAL.
 - OPERATION: 60 INCHES, TO ASSURE PROPER OUTDOOR FAN OPERATION.
 - BETWEEN UNITS: CONTROL BOX SIDE, 42 INCHES PER NEC. SIDE 36 INCHES PER NEC. CONCRETE WALLS AND OTHER GROUNDED SURFACES: CONTROL BOX SIDE, 42 INCHES PER NEC. WITH EXCEPTION OF THE CLEARANCE FOR THE OUTDOOR COIL AS STATED IN NOTE 1B, A REMOVABLE FENCE OR BARICADE REQUIRED TO CLIMB UP ON THE UNIT FROM WOOD OR CLASS A, B OR C ROOF COVERING MATERIAL.

UNIT	SUCTION	LIQUID	QTY
38AUZ25	1-3/8 [41.31]	5/8 [15.9]	1 EA
38AUD25	1-3/8 [34.9]	1/2 [12.7]	2 EA
38AUD28	1-3/8 [34.9]	1/2 [12.7]	2 EA

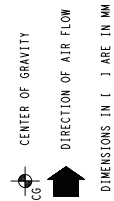
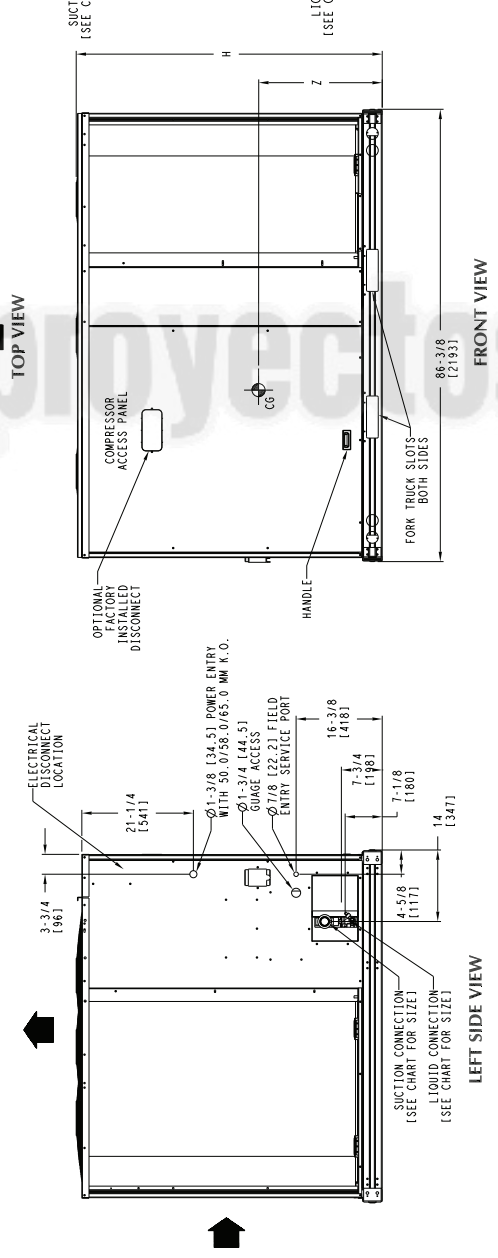
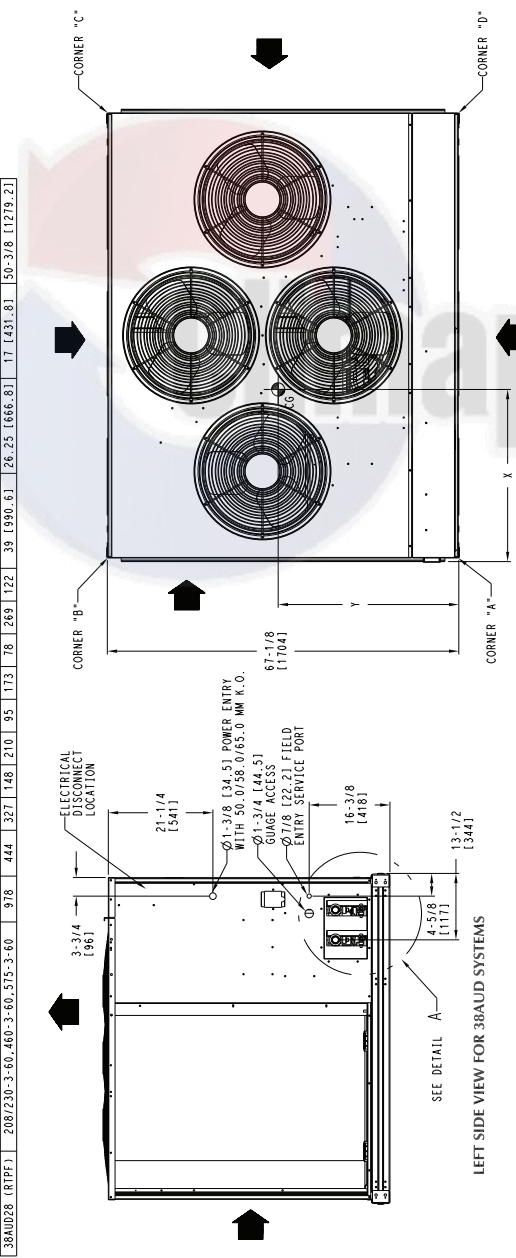

DIMENSIONS IN () ARE IN MM

DATE	SUPERCEDES	38AUZ , 38AUD CONDENSING UNIT	38AU500370	G
4/6/23	9/1/22			

ITEM	FACTORY-INSTALLED OPTION	FIELD-INSTALLED ACCESSORY
Condenser Coil Grille		X
E-Coated Aluminum-Fin Coils	X	
Louvered Hail Guard	X	X
Low-Ambient Temperature Kit	X	X
Non-Fused Disconnect Switch ^a	X	
Powered Convenience Outlet	X	
Pre-Coated Coils	X	
Staged Air Volume (SAV)	X ^b	
Thermostats		X
Unpowered Convenience Outlet	X	

NOTE(S):

- a. Non-fused disconnect switch cannot be used when unit MOCP electrical rating exceeds 80 amps.
- b. Requires pairing with 40RFA/40RUA series packaged air handler.

38AUZ/38AUD Factory-Installed Options

E-Coated Aluminum-Fin Coils

These coils have a flexible and durable epoxy coating uniformly applied to all coil surfaces. Unlike brittle phenolic dip and bake coatings, E-coating provides superior protection with unmatched flexibility, edge coverage, metal adhesion, thermal performance, and most importantly, corrosion resistance.

Pre-Coated Coils

These coils provide protection in mild coastal environments.

Staged Air Volume (SAV™) System

Our SAV units will automatically adjust the indoor fan motor speed in sequence with the unit's cooling operation. Per ASHRAE 90.1 2010 standard section 6.4.3.10.b, during the first stage of cooling operation the fan motor (either ECM or controlled by VFD) will adjust to provide two-thirds of the total cfm established for the unit. When a call for the second stage of cooling is required, the fan motor will allow the total cfm (100%) established for the unit. During the

heating mode the fan motor will allow total design cfm (100%) operation and during the ventilation mode the fan motor will allow operation to two-thirds of total cfm.

Low-Ambient Temperature Kit (-20°F [-29°C])

This kit controls outdoor-fan motor operation to maintain the correct head pressure at low outdoor ambient temperatures.

Louvered Hail Guard

This guard protects coils against damage from flying debris and hail.

Non-Fused Disconnect Switch

This switch is used to remove power locally at the condensing unit. This switch also includes a power lockout capability to protect the service person. This lockout switch saves the service person time and effort because there is no need to access a distant disconnect switch while servicing the unit.

NOTE: Non-fused disconnect switch cannot be used when unit MOCP electrical rating exceeds 80 amps.

38AUZ/D Field-Installed Accessories

Low-Ambient Temperature Kit (-20°F [-29°C])

This accessory controls outdoor-fan motor operation to maintain the correct head pressure at low outdoor ambient temperatures.

Louvered Hail Guard

This guard protects coils against damage from flying debris and hail.

Condenser Coil Grille

This grille protects the condensing unit coil from impact by large objects and vandalism.

Thermostats

These accessories provide both programmable and non-programmable capability with the new Carrier line of commercial programmable thermostats. The Commercial Electronic thermostats provide 7-day programmable capability for economical applications.

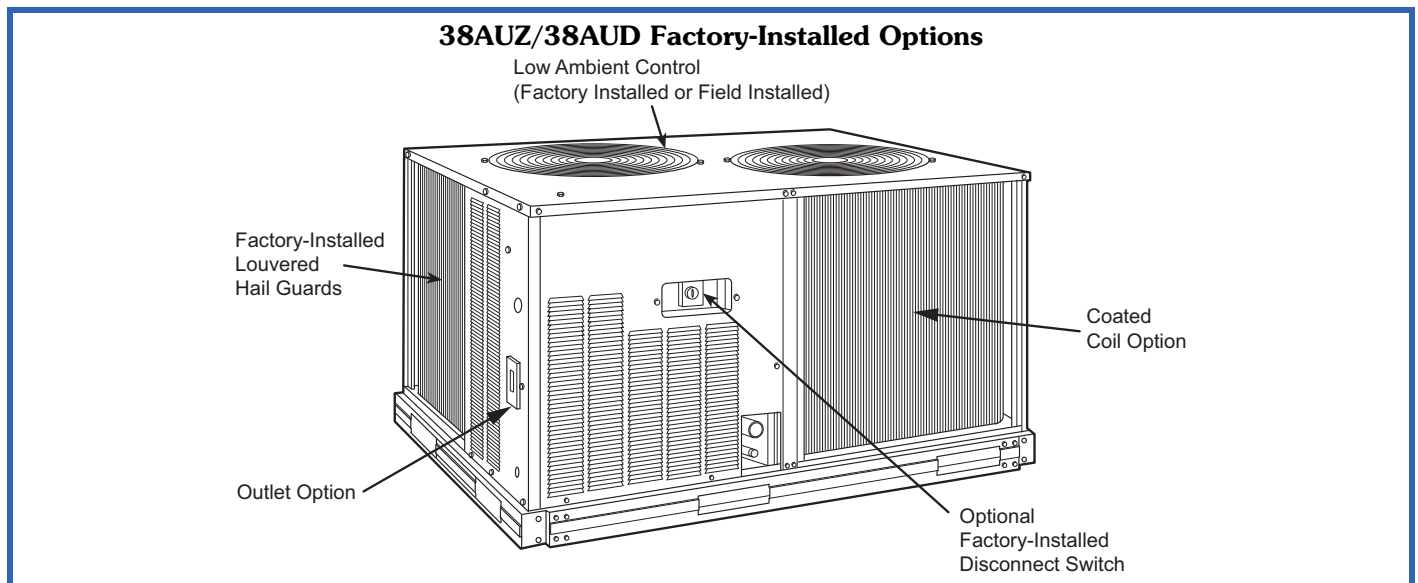

ITEM	FACTORY-INSTALLED OPTION	FIELD-INSTALLED ACCESSORY
Alternate Fan Motors (40RUA only)	X	
Alternate Drives (40RUA only)	X	
CO ₂ Sensors		X
Condensate Drain Trap		X
Discharge Duct Adapter (40RFA only)		X
Discharge Plenum		X
Economizer		X
Electric Heater		X
Hot Water Heating Coils (2 row)		X
Optional VFD Display Kit (40RUA only)		X
Overhead Suspension Package		X
Pre-painted Units	X	
Programmable Thermostats		X
Return Air Grille		X
Steam Heating Coil (1 row)		X

40RFA/RUA Factory-Installed Options

Alternate Fan Motors and Drives (40RUA only)

Alternate fan motors and drives are available to provide the widest possible range of performance.

Pre-painted Steel Constructed Units

Pre-painted units are available from the factory for applications that require painted units. Units are painted with American Sterling Gray color.

40RFA/RUA Field-Installed Accessories

Optional VFD display Kit (40RUAonly)

There is an optional VFD display kit offered (as an accessory) for 40RUA units to allow the user to troubleshoot any VFD faults in the field after start-up.

NOTE: Do not use the VFD display kit to adjust the frequency and voltage in the VFD to required performance requirements. This could lead to decreased life of the motor and VFD.

Two-Row Hot Water Coils

Two-row hot water coils have copper tubes mechanically bonded to aluminum plate fins and non-ferrous headers.

One-Row Steam Coil

One-row steam coils have copper tubes and aluminum fins. The Inner Distributing Tube (IDT) design provides uniform temperatures across the coil face. The steam coil has a broad operating pressure range; up to 20 psi (138 kPag) at 260°F (126°C). The IDT steam coils are especially suited to applications where sub-freezing air enters the unit.

Electric heater

Electric heaters are available as factory-supplied, field-installed accessories for nominal 240v, 480v, and 575v, 3-phase, 60 Hz units. Electric heaters are ETL (U.S.A.) and ETL, Canada, agency-approved. They have single-point power wiring. The heater assembly includes contactors with 24-v coils, power wiring, 24-v control wiring terminal blocks, and a hinged access panel. Electric heaters should not be used with an air discharge plenum.

Economizer

Provides ventilation air and provides “free” cooling if the outside ambient temperature and humidity are suitable. The economizer can also be used in conjunction with Carrier Comfort System thermostats and CO₂ sensors to help meet indoor air quality requirements. The economizer can be used in both vertical and horizontal positions.

Discharge Plenum

Discharge plenum directs the air discharge directly into the occupied space; integral horizontal and vertical louvers enable redirection of airflow. This accessory is available unpainted or painted. Field assembly is required (only applicable for vertical application).

Return-Air Grille

The return-air grille provides a protective barrier over the return-air opening and gives a finished appearance to units installed in the occupied space. This accessory is available unpainted or painted.

Overhead suspension package

The overhead suspension package includes necessary brackets to support units in horizontal ceiling installations.

CO₂ sensors

CO₂ sensors can be used in conjunction with the economizer accessory to help meet indoor air quality requirements. The sensor signals the economizer to open when the CO₂ level in the space exceeds the set point. A Carrier Comfort System programmable thermostat can be used to override the sensor if the outside-air temperature is too high or too low.

Condensate drain trap

The condensate drain trap includes an overflow shutoff switch that can be wired to turn off the unit if the trap becomes plugged. Kit also includes a wire harness that can be connected to an alarm if desired. The transparent trap is designed for easy service and maintenance.

Discharge duct adapter

This accessory is required for replacements using 40RFA units with or without electric heat. It is not required for new installations or when using steam coil, hot water coil, or discharge plenum accessories.

40RFA/RUA with Discharge Plenum Return-Air Grille and Subbase

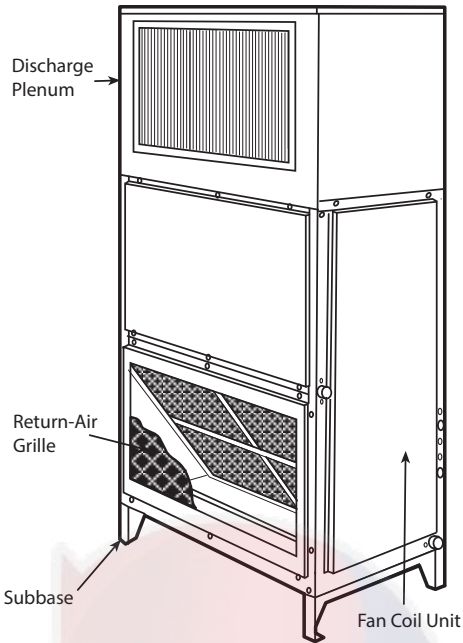

40RFA/RUA with Hot Water or Steam Coil

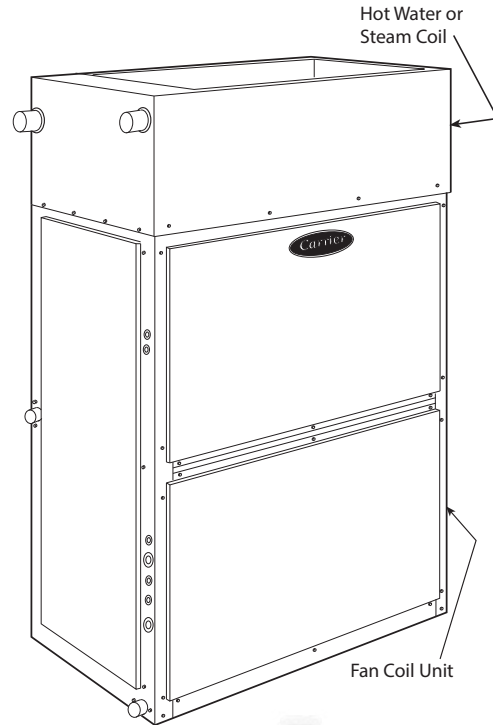

40RFA/RUA with Economizer

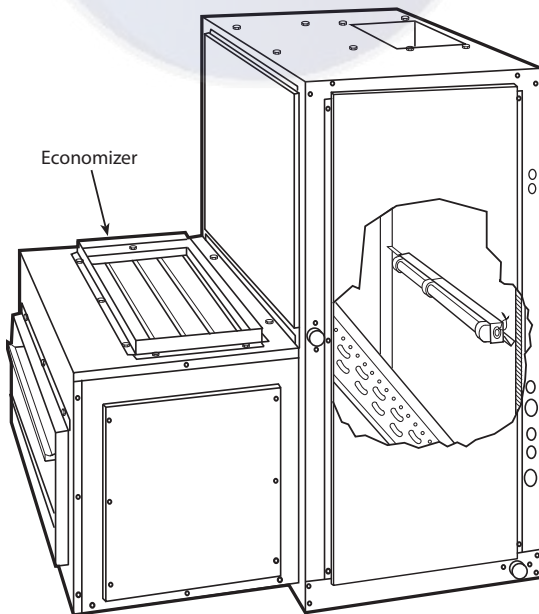

40RFA/RUA with Condensate Trap

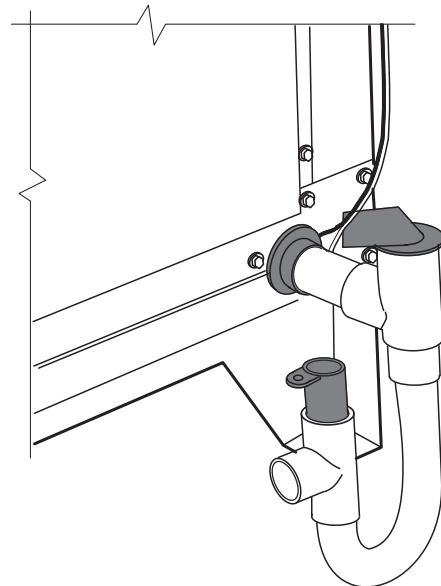

Climaproyectos

Typical Single Circuit/Two-Stage Wiring Diagram, 6 Ton — 460-3-60 Units

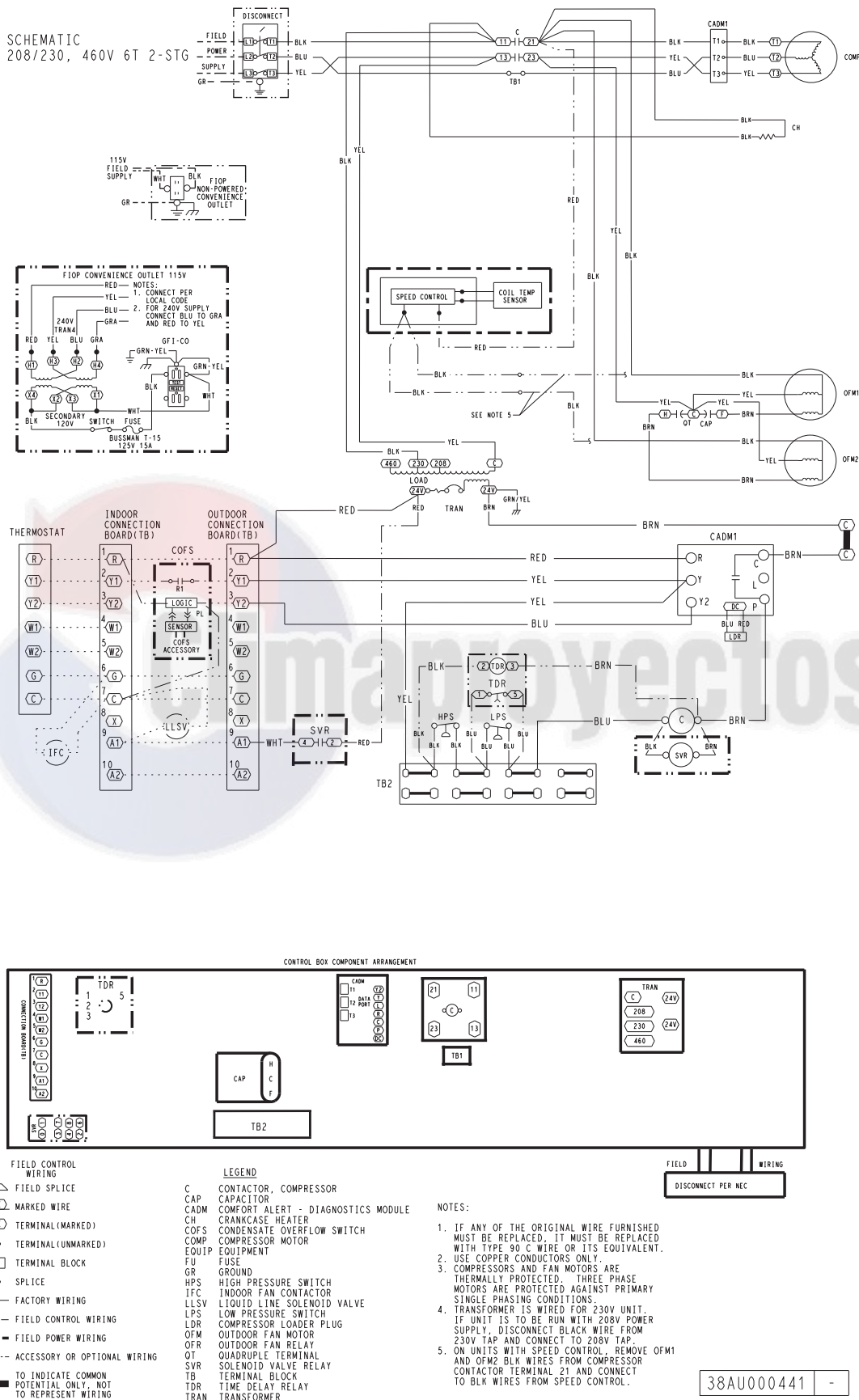

Typical Single Circuit/Two-Stage Wiring Diagram, 7.5 Ton — 460-3-60 Units

SCHEMATIC
460V 7.5T SNGL, 2 STG

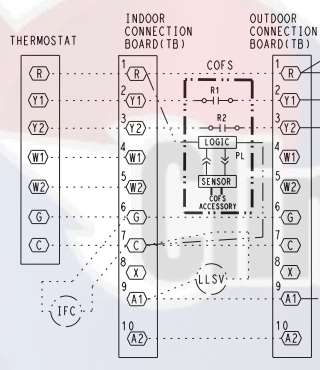
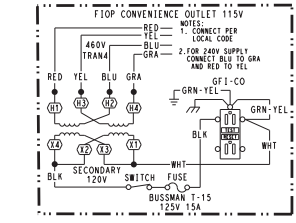
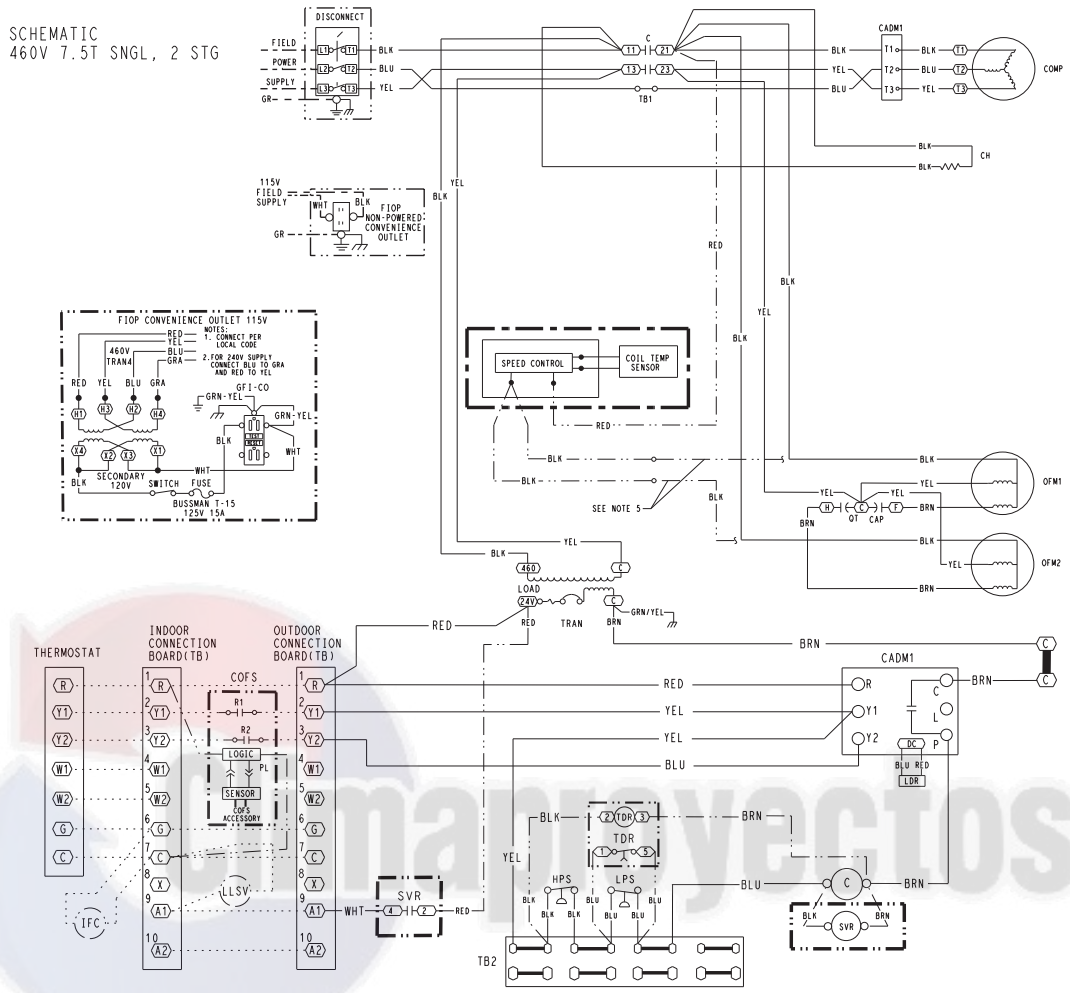

CONTROL BOX COMPONENT ARRANGEMENT

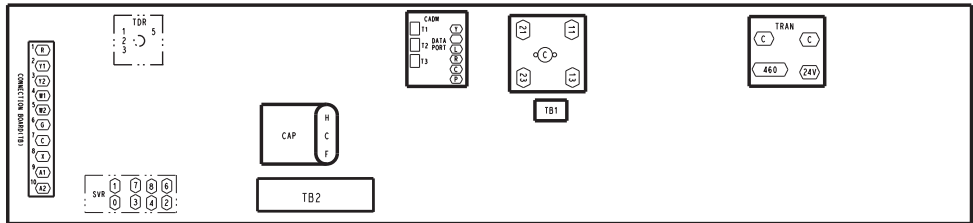

- | | |
|--|--|
| <p>FIELD CONTROL WIRING</p> <p>△ FIELD SPLICE</p> <p>(X) MARKED WIRE</p> <p>(X) TERMINAL (MARKED)</p> <p>○ TERMINAL (UNMARKED)</p> <p>(X) TERMINAL BLOCK</p> <p>• SPLICE</p> <p>— FACTORY WIRING</p> <p>- - - FIELD CONTROL WIRING</p> <p>--- FIELD POWER WIRING</p> <p>--- ACCESSORY OR OPTIONAL WIRING</p> <p>— TO INDICATE COMMON POTENTIAL ONLY, NOT TO REPRESENT WIRING</p> | <p>LEGEND</p> <p>C CONTACTOR, COMPRESSOR</p> <p>CAP CAPACITOR</p> <p>CADM COMFORT ALERT - DIAGNOSTICS MODULE</p> <p>CH CRANKCASE HEATER</p> <p>COFS CONDENSATE OVERFLOW SWITCH</p> <p>COMP COMPRESSOR MOTOR</p> <p>CTD CYCLE TIMER DEVICE</p> <p>CTR COMPRESSOR TIMERR RELAY</p> <p>DCS DIGITAL COMPRESSOR SOLENOID EQUIP</p> <p>FU FUSE</p> <p>GR GROUND</p> <p>HPS HIGH PRESSURE SWITCH</p> <p>IFC INDOOR FAN CONTACTOR</p> <p>LDR COMPRESSOR LOADER PLUG</p> <p>LLSV LIQUID LINE SOLENOID VALVE</p> <p>LPS LOW PRESSURE SWITCH</p> <p>OFM OUTDOOR FAN MOTOR</p> <p>OFR OUTDOOR FAN RELAY</p> <p>OT QUADRUPLE TERMINAL</p> <p>SVR SOLENOID VALVE RELAY</p> <p>TB TERMINAL BLOCK</p> <p>TDR TIME DELAY RELAY</p> <p>TRAN TRANSFORMER</p> |
|--|--|

- NOTES:**
1. IF ANY OF THE ORIGINAL WIRE FURNISHED MUST BE REPLACED, IT MUST BE REPLACED WITH TYPE 90 C WIRE OR ITS EQUIVALENT.
 2. USE COPPER CONDUCTORS ONLY.
 3. COMPRESSORS AND FAN MOTORS ARE THERMALLY PROTECTED. THREE PHASE MOTORS ARE PROTECTED AGAINST PRIMARY SINGLE PHASING CONDITIONS.
 4. TRANSFORMER IS WIRED FOR 230V UNIT. IF THE UNIT IS TO BE RUN WITH 208V POWER SUPPLY, DISCONNECT BLACK WIRE FROM 230V TAP AND CONNECT TO 208V TAP.
 5. ON UNITS WITH SPEED CONTROL, REMOVE OFM1 AND OFM2 BLK WIRES FROM COMPRESSOR CONTACTOR TERMINAL 21 AND CONNECT TO BLK WIRES FROM SPEED CONTROL.

38AU000760 -

Typical Single Circuit/Two-Stage Wiring Diagram, 10 Ton — 460-3-60 Units

SCHEMATIC
10T 460V SNGL

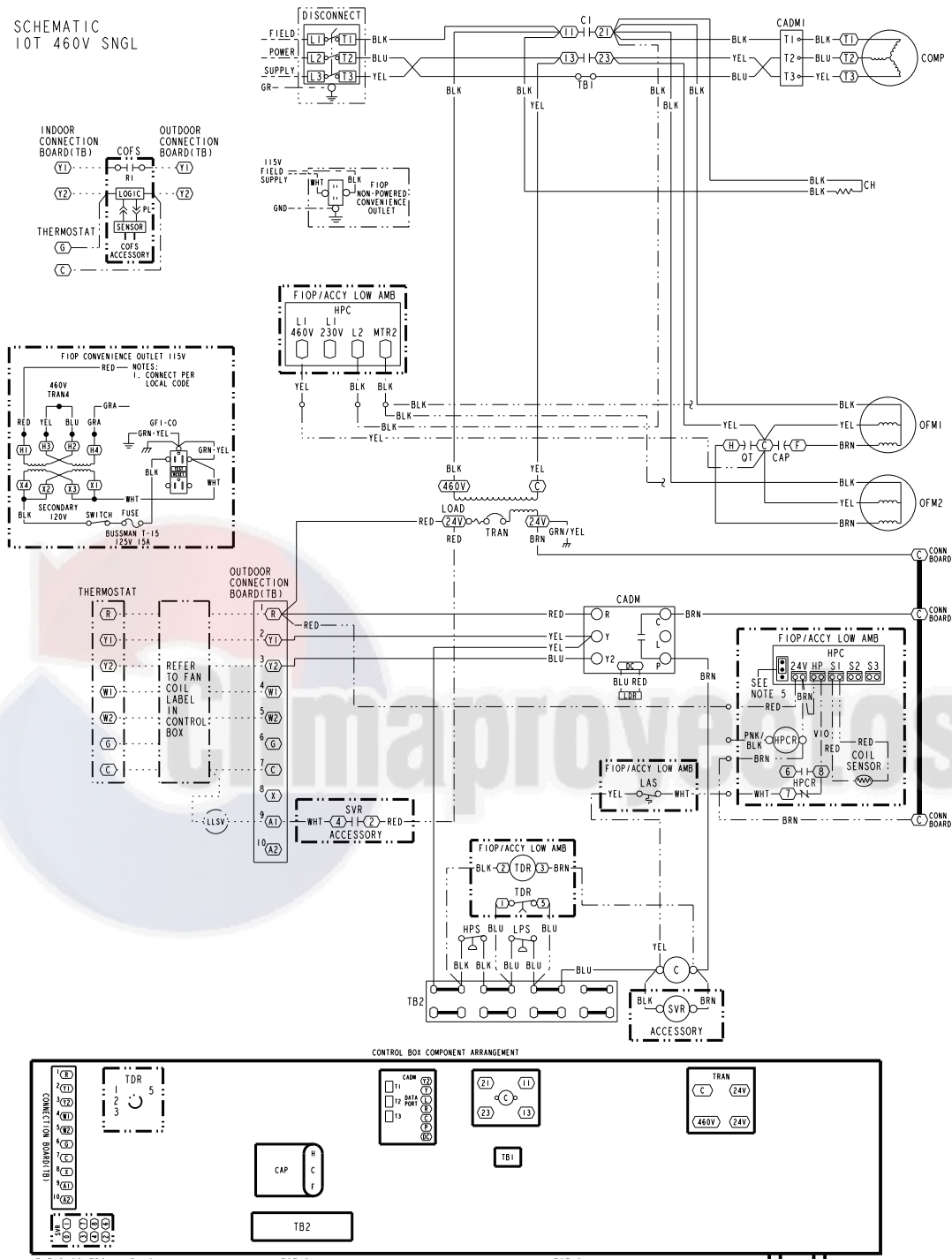

- FIELD CONTROL WIRING**
- △ FIELD SPLICE
 - (X) MARKED WIRE
 - (X) TERMINAL (MARKED)
 - () TERMINAL (UNMARKED)
 - TERMINAL BLOCK
 - SPLICE
 - FACTORY WIRING
 - - - FIELD CONTROL WIRING
 - - - FIELD POWER WIRING
 - - - ACCESSORY OR OPTIONAL WIRING
 - TO INDICATE COMMON POTENTIAL ONLY, NOT TO REPRESENT WIRING

- LEGEND**
- C CONTACTOR, COMPRESSOR
 - CAP CAPACITOR
 - CADM COMFORT ALERT - DIAGNOSTICS MODULE
 - CH CRANKCASE HEATER
 - CLR COMPRESSOR LOCK-OUT RELAY
 - COFS CONDENSATE OVERFLOW SWITCH
 - COMP COMPRESSOR MOTOR
 - EQUIP EQUIPMENT
 - FU FUSE
 - GR GROUND
 - HPC HEAD PRESSURE CONTROL
 - HPCR HEAD PRESSURE CONTROL RELAY
 - HPS HIGH PRESSURE SWITCH
 - IFC INDOOR FAN CONTACTOR
 - LAR LOW AMBIENT RELAY
 - LAS LOW AMBIENT TEMP SWITCH
 - LDR COMPRESSOR LOADER PLUG
 - LLSV LIQUID LINE SOLENOID VALVE
 - LPS LOW PRESSURE SWITCH
 - OFM OUTDOOR FAN MOTOR
 - OFR OUTDOOR FAN RELAY
 - OT QUADRUPLE TERMINAL

- LEGEND**
- SVR SOLENOID VALVE RELAY
 - TB TERMINAL BLOCK
 - TDR TIME DELAY RELAY
 - TRAN TRANSFORMER

- NOTES:**
1. IF ANY OF THE ORIGINAL WIRE FURNISHED MUST BE REPLACED, IT MUST BE REPLACED WITH TYPE 90 C WIRE OR ITS EQUIVALENT.
 2. USE COPPER CONDUCTORS ONLY.
 3. COMPRESSORS AND FAN MOTORS ARE THERMALLY PROTECTED. THREE PHASE MOTORS ARE PROTECTED AGAINST PRIMARY SINGLE PHASING CONDITIONS.
 4. TRANSFORMER IS WIRED FOR 460V UNIT.
 5. HARDSTART AND CUTOFF SET TO "MIN". JUMPER PIN ON TOP 2-PINS AS SHOWN.

38AU501322 A

Typical piping and wiring (cont)



Typical Single Circuit/Two-Stage Wiring Diagram, 12.5 Ton — 460-3-60 Units

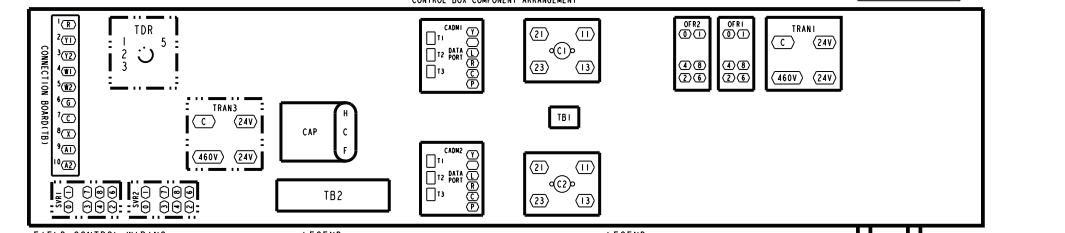
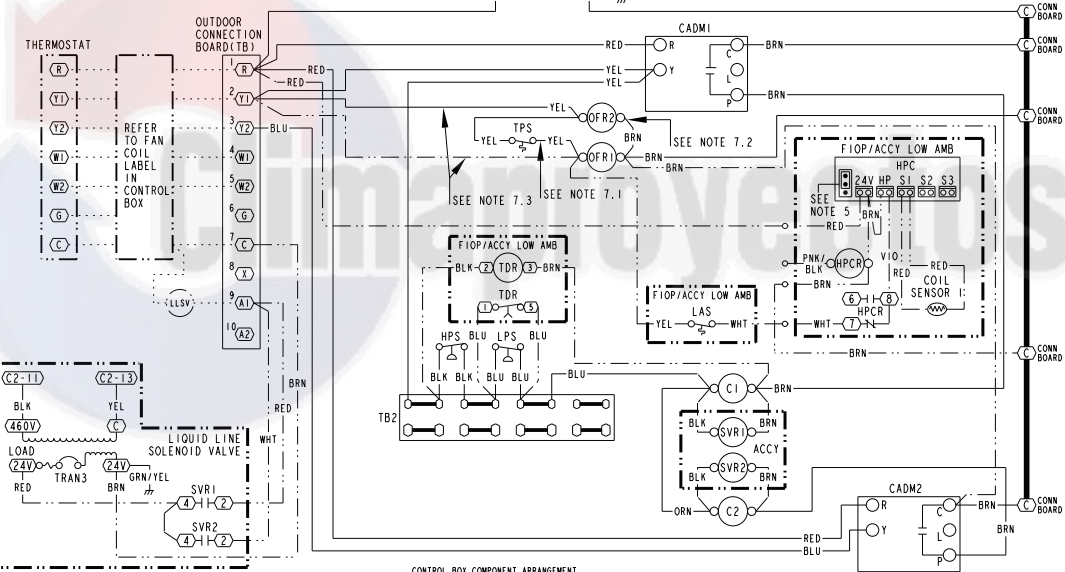
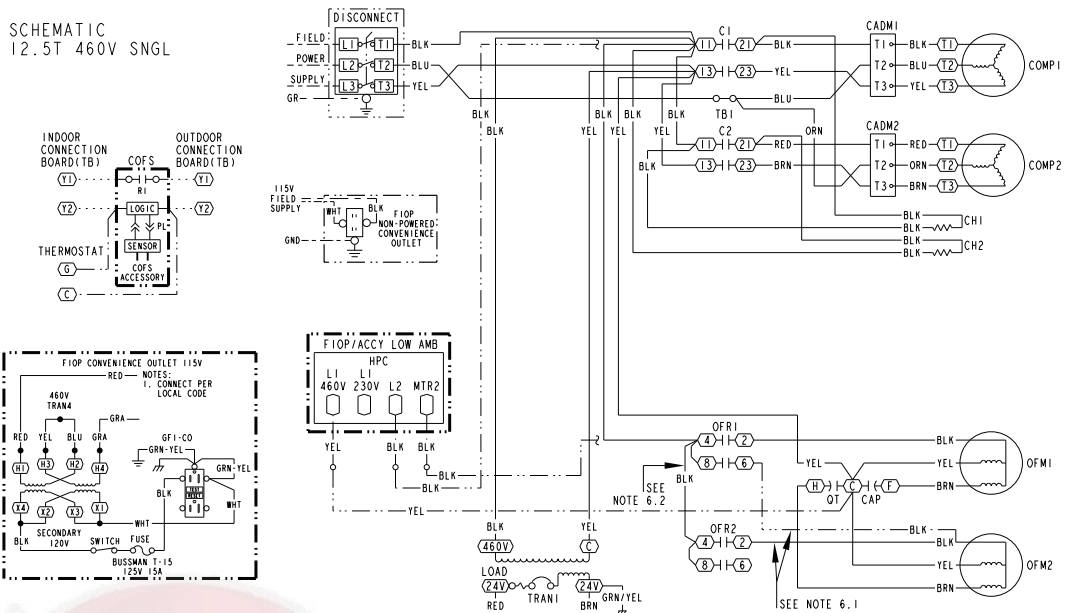

- | | | | |
|--|---|---|--|
| <p>FIELD CONTROL WIRING</p> <ul style="list-style-type: none"> △ FIELD SPLICE ⓧ MARKED WIRE ⓧ TERMINAL (MARKED) ○ TERMINAL (UNMARKED) ⓧ TERMINAL BLOCK • SPLICE — FACTORY WIRING - - - FIELD CONTROL WIRING - - - FIELD POWER WIRING - - - ACCESSORY OR OPTIONAL WIRING — TO INDICATE COMMON POTENTIAL ONLY, NOT TO REPRESENT WIRING | <p>LEGEND</p> <ul style="list-style-type: none"> C CONTACTOR, COMPRESSOR CAP CAPACITOR CADM COMFORT ALERT - DIAGNOSTICS MODULE CH CRANKCASE HEATER CLR COMPRESSOR LOCK-OUT RELAY COFS CONDENSATE OVERFLOW SWITCH COMP COMPRESSOR MOTOR EQUIP EQUIPMENT FU FUSE GR GROUND HPC HEAD PRESSURE CONTROL HPCR HEAD PRESSURE CONTROL RELAY HPS HIGH PRESSURE SWITCH IFC INDOOR FAN CONTACTOR LAR LOW AMBIENT RELAY LAS LOW AMBIENT TEMP SWITCH LDR COMPRESSOR LOADER PLUG LLSV LIQUID LINE SOLENOID VALVE LPS LOW PRESSURE SWITCH OFM OUTDOOR FAN MOTOR OFR OUTDOOR FAN RELAY OT QUADRUPLE TERMINAL | <p>LEGEND</p> <ul style="list-style-type: none"> SVR SOLENOID VALVE RELAY TB TERMINAL BLOCK TDR TIME DELAY RELAY TRAN TRANSFORMER <p>NOTES:</p> <ol style="list-style-type: none"> 1. IF ANY OF THE ORIGINAL WIRE FURNISHED MUST BE REPLACED, IT MUST BE REPLACED WITH TYPE 90 C WIRE OR ITS EQUIVALENT. USE COPPER CONDUCTORS ONLY. 2. USE COPPER CONDUCTORS ONLY. 3. COMPRESSORS AND FAN MOTORS ARE THERMALLY PROTECTED. THREE PHASE MOTORS ARE PROTECTED AGAINST PRIMARY SINGLE PHASING CONDITIONS. 4. TRANSFORMER IS WIRED FOR 460V UNIT. HARDSTART AND CUTOFF SET TO 'MIN'. 5. JUMPER PIN ON TOP 2-PINS AS SHOWN. | <p>FIELD WIRING</p> <p>DISCONNECT PER NEC</p> <p>6. FOR LOW AMBIENT UNITS ONLY:
1. MOVE BLACK WIRE FROM OFR2-2 TO OFR1-6.
2. REMOVE BLACK WIRE FROM OFR1-4 TO OFR2-4.</p> <p>7. FOR LOW AMBIENT UNITS ONLY:
1. DISCONNECT YELLOW WIRES FROM TPS TO OFR1-1 AND FROM TPS TO OFR2-1.
2. DISCONNECT BROWN WIRE FROM OFR2-0 TO OFR1-0.
3. MOVE YELLOW WIRE FROM OFR2-1 TO OFR1-1</p> |
|--|---|---|--|

38AU501325 A

Typical Dual Circuit/Three Stage Wiring Diagram, 15 Ton — 460-3-60 Unit

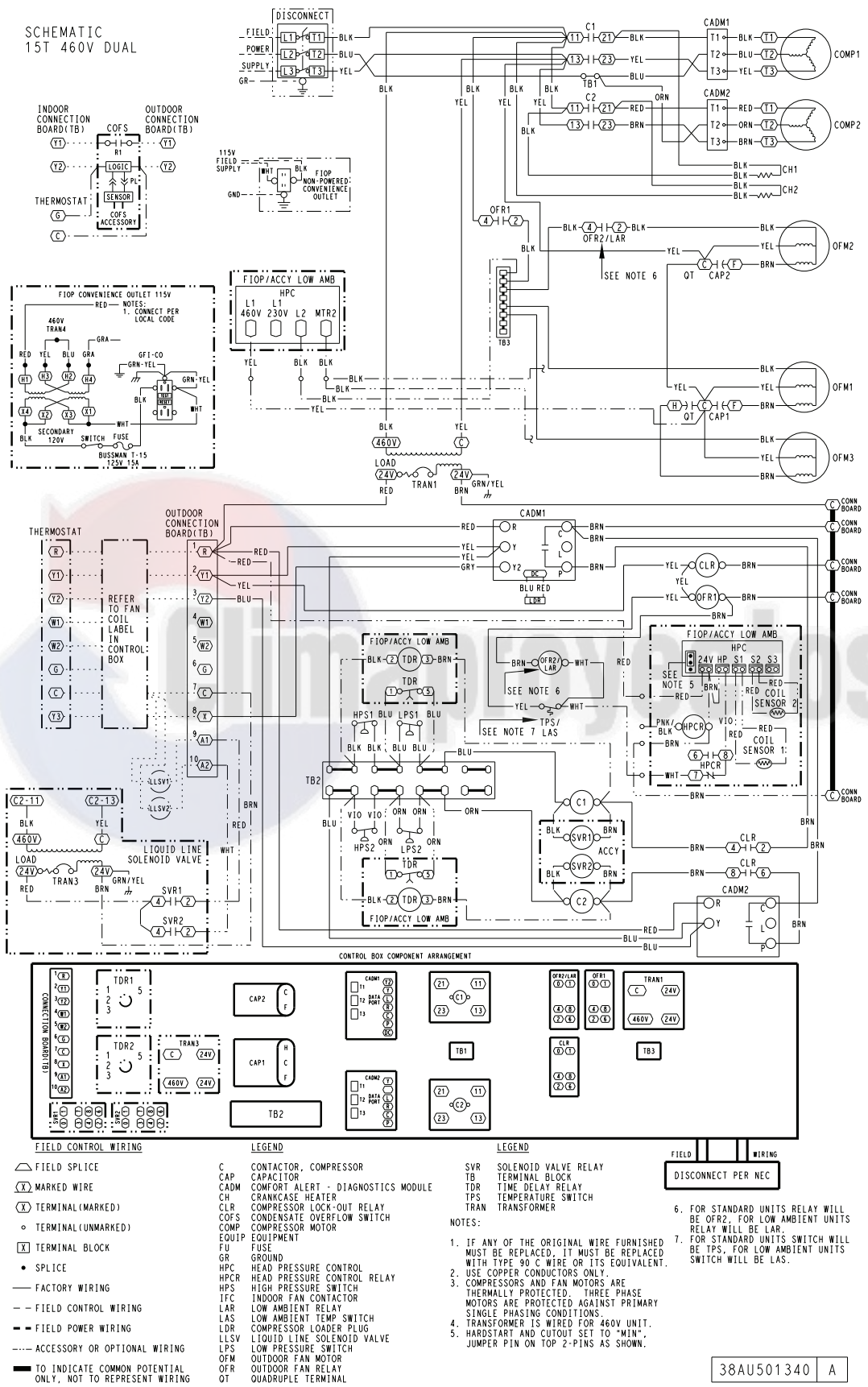

Typical Dual Circuit/Three Stage Wiring Diagram, 20 Ton (460-3-60 Unit Shown)

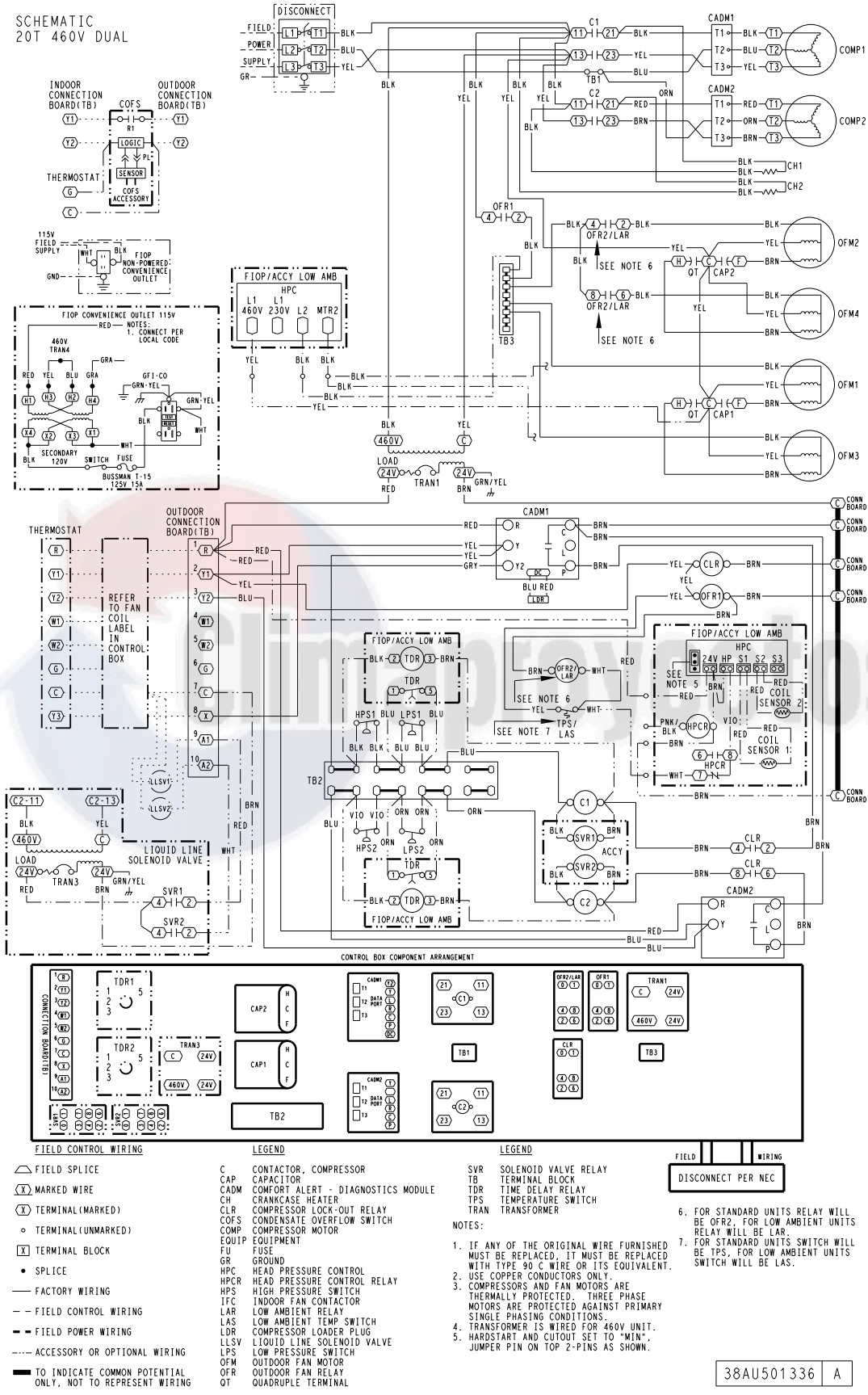

Typical Dual Circuit/Three Stage Wiring Diagram, 25 Ton (460-3-60 Unit Shown)

SCHEMATIC
25T 460V DUAL

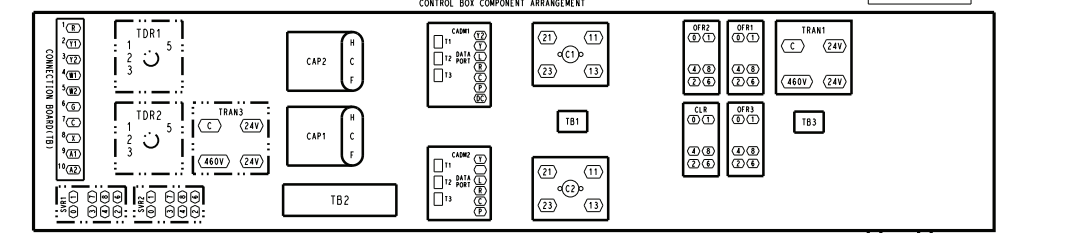
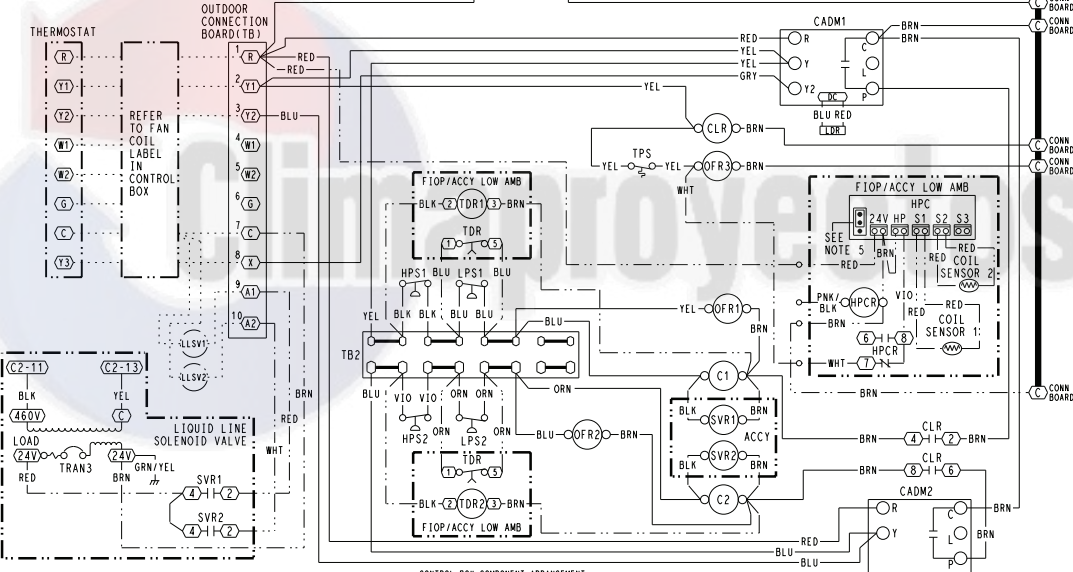
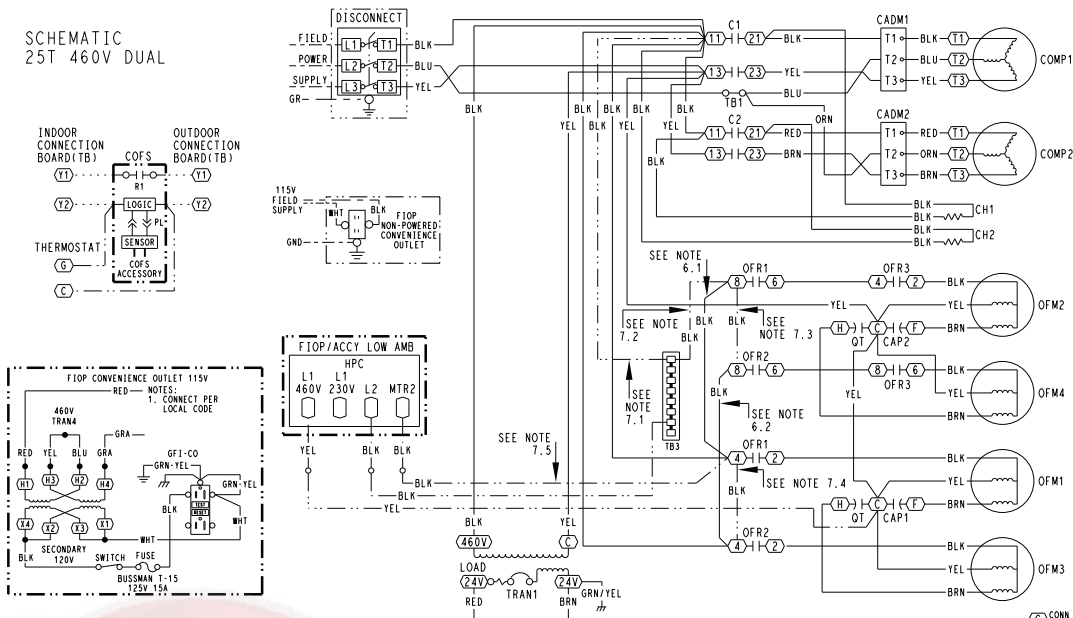

- FIELD CONTROL WIRING**
- △ FIELD SPLICE
 - (X) MARKED WIRE
 - (X) TERMINAL (MARKED)
 - TERMINAL (UNMARKED)
 - [] TERMINAL BLOCK
 - SPLICE
 - FACTORY WIRING
 - - - FIELD CONTROL WIRING
 - - - FIELD POWER WIRING
 - - - ACCESSORY OR OPTIONAL WIRING
 - TO INDICATE COMMON POTENTIAL ONLY, NOT TO REPRESENT WIRING
- LEGEND**
- C CONTACTOR, COMPRESSOR
 - CAP CAPACITOR
 - CADM COMFORT ALERT - DIAGNOSTICS MODULE
 - CH CRANKCASE HEATER
 - CLR COMPRESSOR LOCK-OUT RELAY
 - COFS CONDENSATE OVERFLOW SWITCH
 - COMP COMPRESSOR MOTOR
 - EQUIP EQUIPMENT
 - FU FUSE
 - GR GROUND
 - HPC HEAD PRESSURE CONTROL
 - HPSR HEAD PRESSURE SWITCH RELAY
 - HPS HIGH PRESSURE SWITCH
 - IFC INDOOR FAN CONTACTOR
 - LAR LOW AMBIENT RELAY
 - LAS LOW AMBIENT TEMP SWITCH
 - LDR COMPRESSOR LOADER PLUG
 - LLSV LIQUID LINE SOLENOID VALVE
 - LPS LOW PRESSURE SWITCH
 - OFM OUTDOOR FAN MOTOR
 - OFR OUTDOOR FAN RELAY
 - OT QUADRUPLE TERMINAL
- LEGEND**
- SVR SOLENOID VALVE RELAY
 - TB TERMINAL BLOCK
 - TDR TIME DELAY RELAY
 - TPS TEMPERATURE SWITCH
 - TRAN TRANSFORMER
- NOTES:**
1. IF ANY OF THE ORIGINAL WIRE FURNISHED MUST BE REPLACED, IT MUST BE REPLACED WITH TYPE 90 C WIRE OR ITS EQUIVALENT.
 2. USE COPPER CONDUCTORS ONLY.
 3. COMPRESSORS AND FAN MOTORS ARE THERMALLY PROTECTED. THREE PHASE MOTORS ARE PROTECTED AGAINST PRIMARY SINGLE PHASING CONDITIONS.
 4. TRANSFORMER IS WIRED FOR 460V UNIT.
 5. HARDSTART AND CUTOFF SET TO "MIN". JUMPER PIN ON TOP 2-PINS AS SHOWN.
- NOTES:**
6. ON STANDARD UNITS:
 1. OFR1-4 CONNECTS TO OFR1-8 AND C1-11
 2. OFR2-4 CONNECTS TO OFR2-8 AND C1-11
 7. ON LOW AMBIENT UNITS:
 1. C1-11 CONNECTS TO TB3
 2. TB3 CONNECTS TO OFR1-8 AND HPC-L2
 3. OFR1-8 CONNECTS TO OFR2-8
 4. OFR1-4 CONNECTS TO OFR2-4
 5. HPC-M2 CONNECTS TO OFR1-4

38AU501344 A

Typical Single Circuit/Two Stage Wiring Diagram, 15 Ton (460-3-60 Unit Shown)

SCHMATIC
15T 460V TANDEM

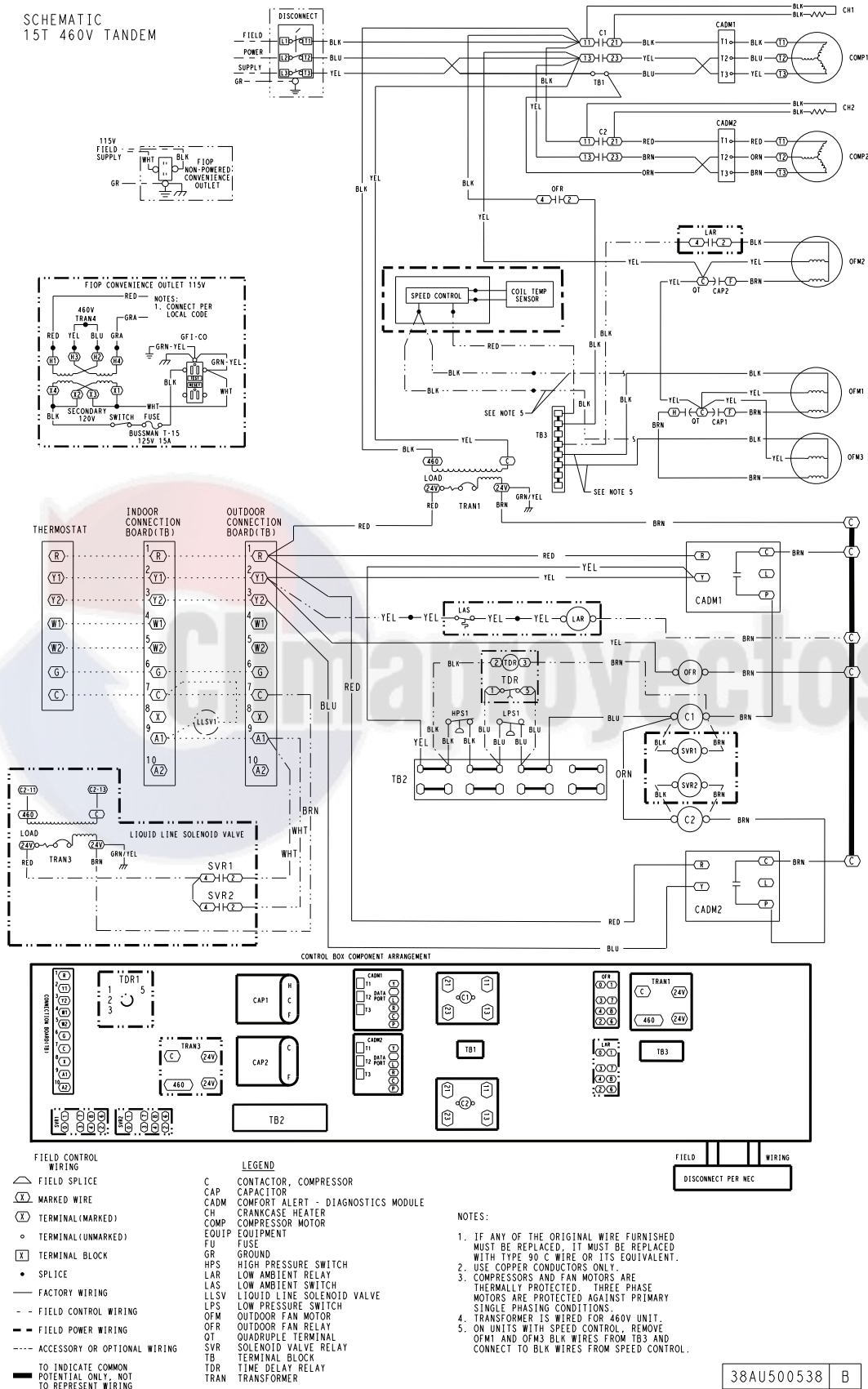

38AU500538 B

Typical Single Circuit/Two Stage Wiring Diagram, 20 Ton (460-3-60 Unit Shown)

SCHEMATIC
20T 460V TANDEM

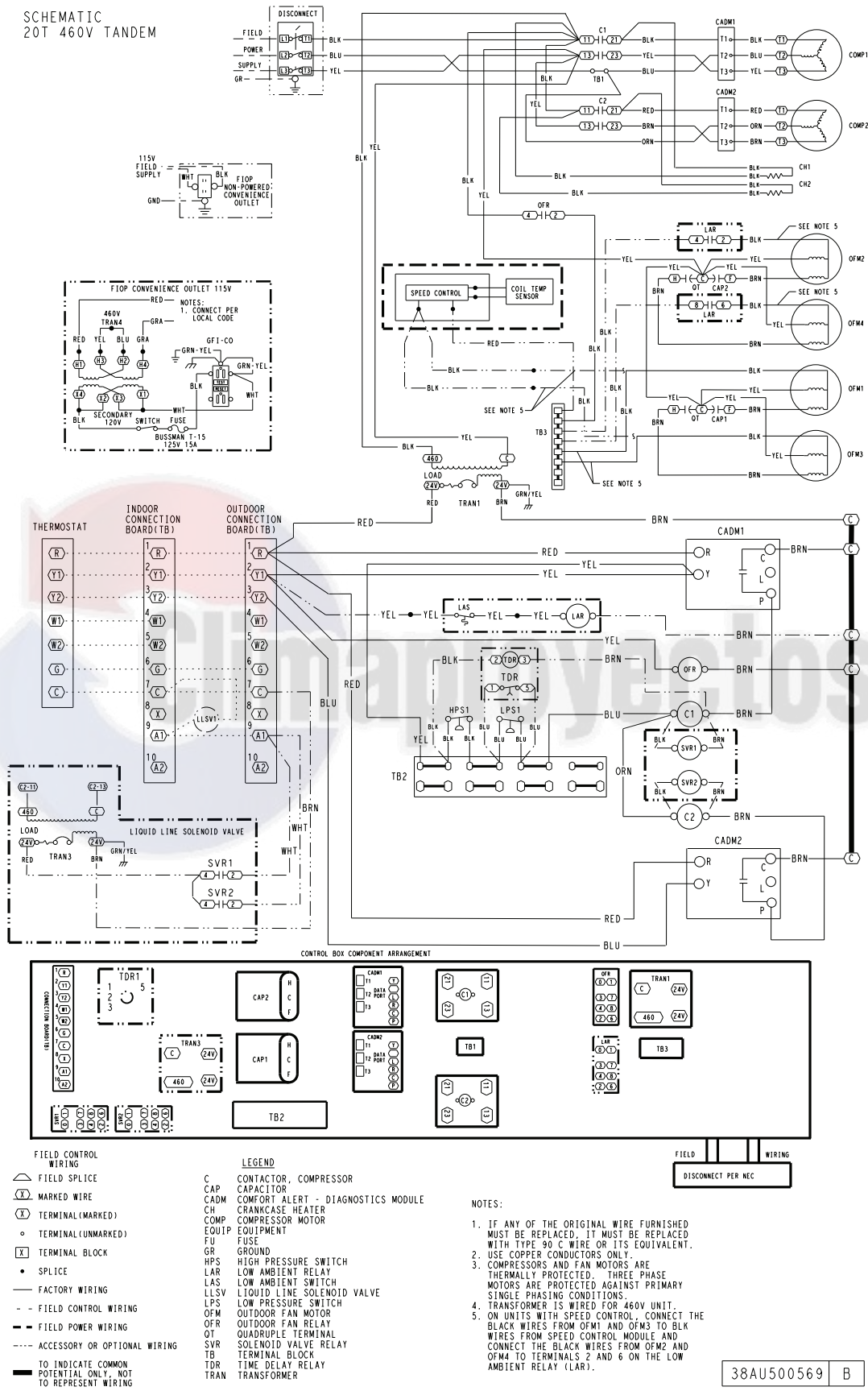

38AU500569 B

Roof Installation and Ceiling-Mounted Fan Coil

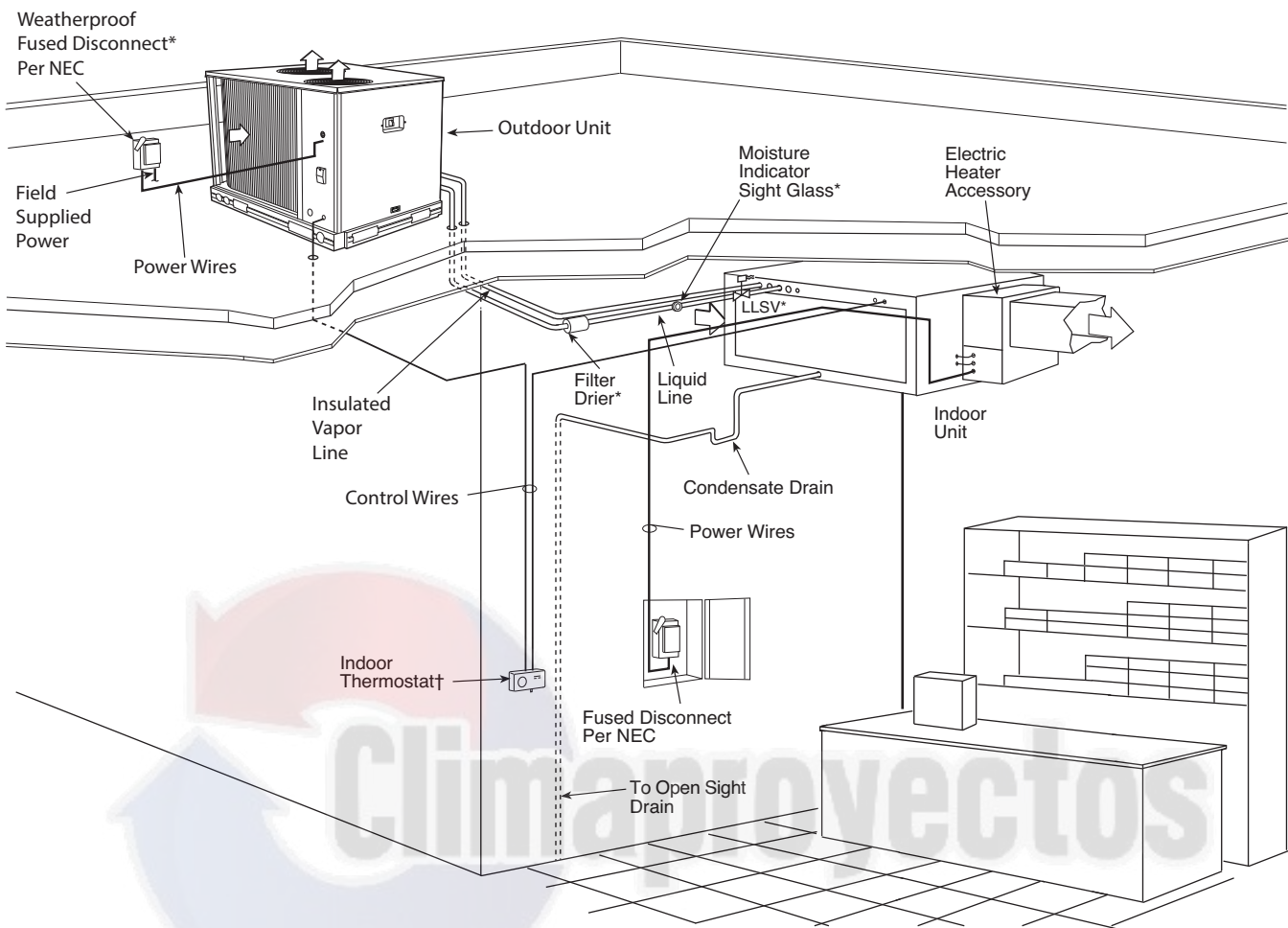

LEGEND

- LLSV** — Liquid Line Solenoid Valve
- NEC** — National Electrical Code
- TXV** — Thermostatic Expansion Valve

* Field-supplied.

† Double riser may be required. Consult condensing unit product data catalog for details.

NOTE(S):

1. All piping must follow standard refrigerant piping techniques. Refer to Carrier System Design Manual for details.
2. All wiring must comply with the applicable local and national codes.
3. Wiring and piping shown are general points-of-connection guides only and are not intended for, or to include all details for, a specific installation.
4. Liquid line solenoid valve (solenoid drop control) is recommended to prevent refrigerant migration to the compressor.
5. Internal factory-supplied TXVs not shown.

Roof Installation and a Vertical Discharge Fan Coil

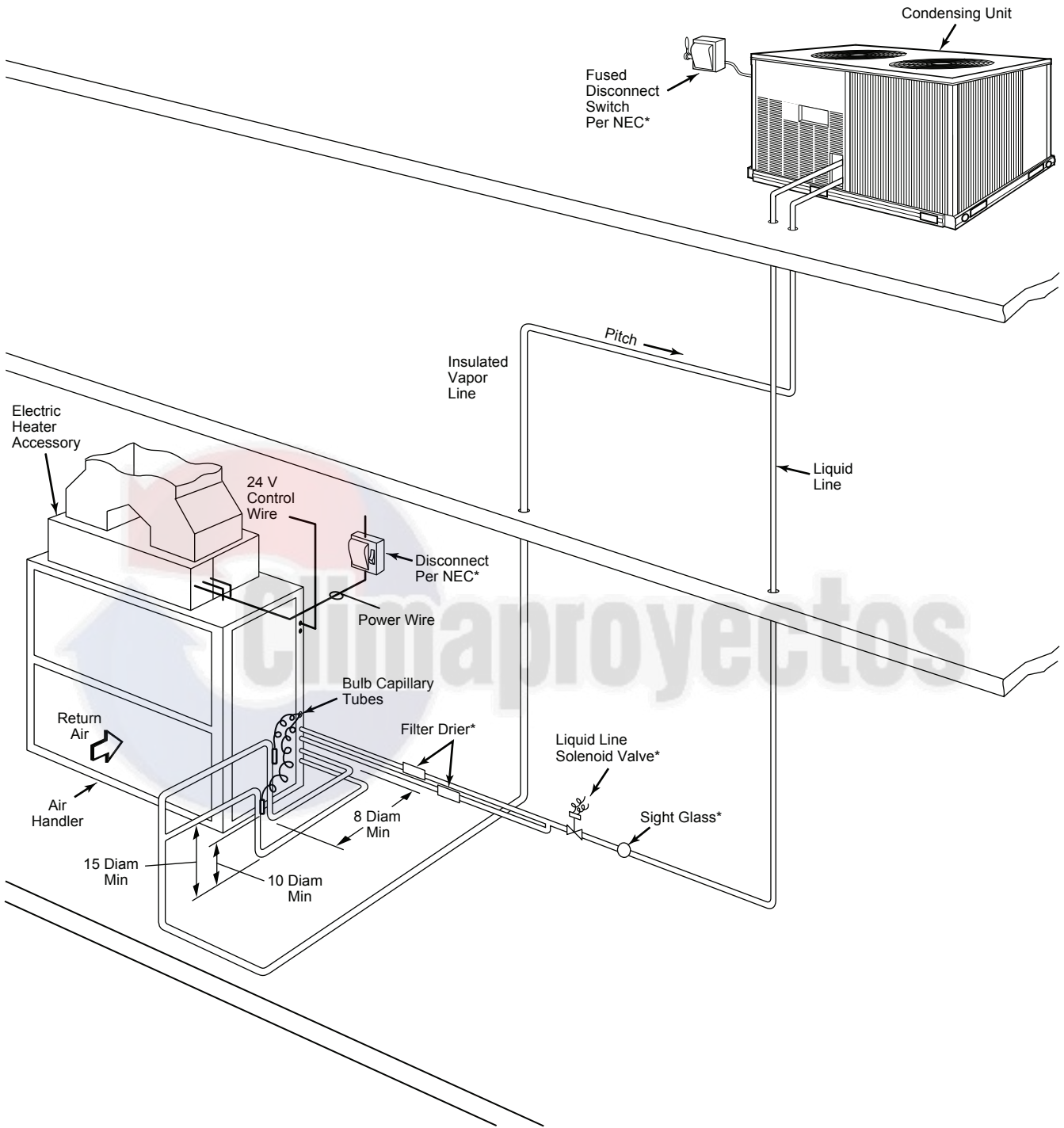

LEGEND

- DIAM** — Diameter
- NEC** — National Electrical Code
- TXV** — Thermostatic Expansion Valve
- Piping

*Field supplied.

NOTE(S):

1. All piping must follow standard refrigerant piping techniques. Refer to System Design Manual for details.
2. All wiring must comply with applicable local and national codes.
3. Wiring and piping shown are general points-of-connection guides only and are not intended for, or to include all details for, a specific installation.
4. Liquid line solenoid valve (solenoid drop control) is recommended to prevent refrigerant migration to the compressor on line links above 75 feet (23 meters).
5. Internal factory-supplied TXVs and check valves not shown.

Ground Installation and Vertical Discharge Fan Coil

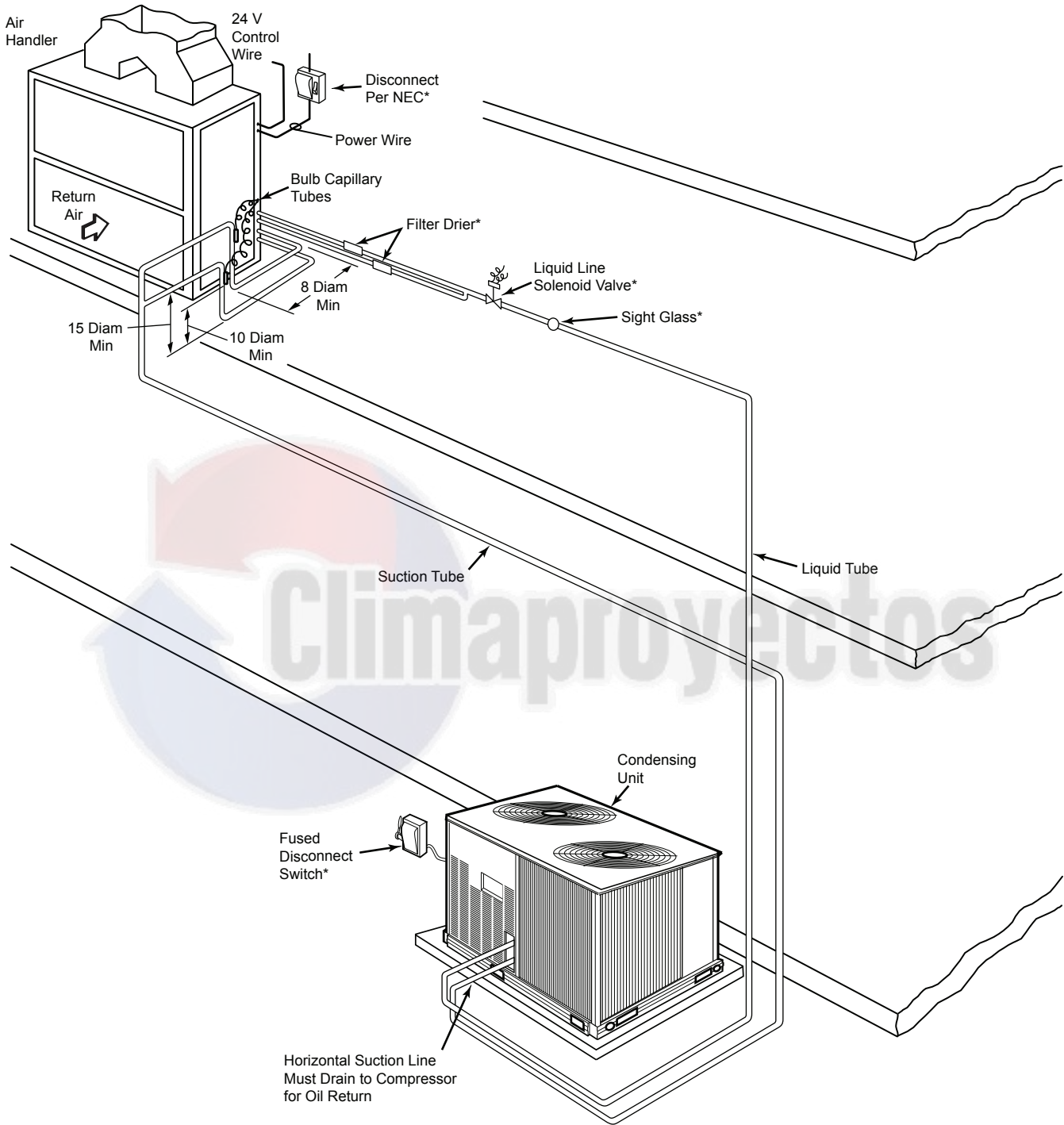

LEGEND

- DIAM** — Diameter
- NEC** — National Electrical Code
- TXV** — Thermostatic Expansion Valve
- Piping

*Field supplied.

NOTE(S):

1. All piping must follow standard refrigerant piping techniques. Refer to System Design Manual for details.
2. All wiring must comply with applicable local and national codes.
3. Wiring and piping shown are general points-of-connection guides only and are not intended for, or to include all details for, a specific installation.
4. Liquid line solenoid valve (solenoid drop control) is recommended to prevent refrigerant migration to the compressor on line links above 75 feet (23 meters).
5. Internal factory-supplied TXVs and check valves not shown.

Dual Condensing Units and a Dual Circuit Fan Coil

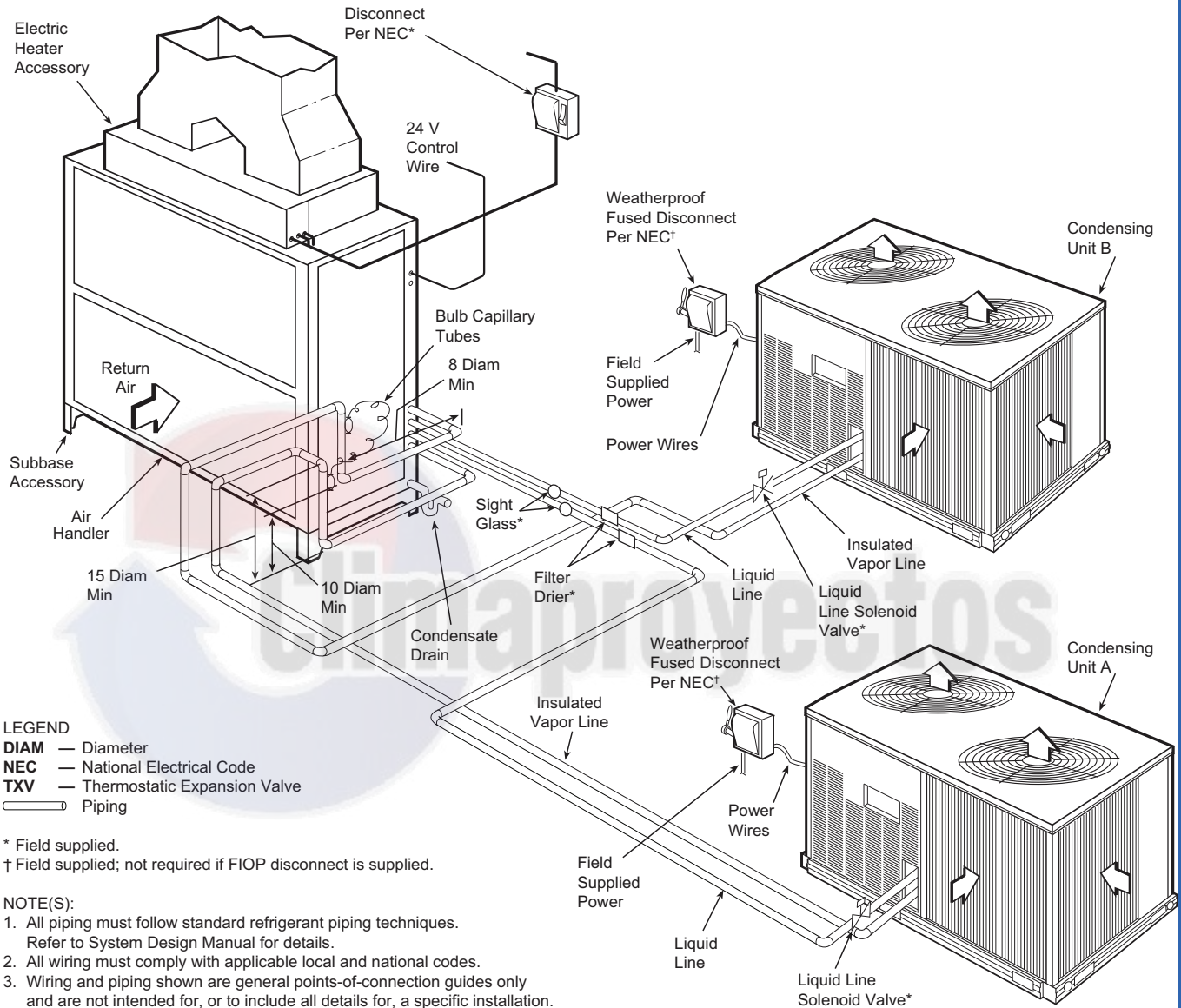

LEGEND
DIAM — Diameter
NEC — National Electrical Code
TXV — Thermostatic Expansion Valve
 Piping

* Field supplied.
 † Field supplied; not required if FIOP disconnect is supplied.

- NOTE(S):**
1. All piping must follow standard refrigerant piping techniques. Refer to System Design Manual for details.
 2. All wiring must comply with applicable local and national codes.
 3. Wiring and piping shown are general points-of-connection guides only and are not intended for, or to include all details for, a specific installation.
 4. Liquid line solenoid valve (solenoid drop control) is recommended to prevent refrigerant migration to the compressor on line links above 75 feet (23 meters).
 5. Condensing Unit A should be the first on, last off and be connected to the lower half of the coil.
 6. Internal factory-supplied TXVs and check valves not shown.

38AUZD07 Total Unit — Condenser Only Ratings — 60 Hz

SST (°F)		38AUZD07					
		Air Temperature Entering Condenser (°F)					
		85	95	100	105	115	125
20	TC	45.9	42.9	41.3	39.7	36.3	32.6
	kW	4.1	4.7	5.1	5.4	6.3	7.3
	SDT	103.5	113.2	118.1	123.0	132.9	142.7
25	TC	50.7	47.5	45.8	44.1	40.5	36.6
	kW	4.2	4.8	5.1	5.5	6.3	7.3
	SDT	104.9	114.6	119.5	124.3	134.2	143.9
30	TC	56.0	52.5	50.7	48.9	45.0	40.9
	kW	4.2	4.8	5.2	5.5	6.4	7.3
	SDT	106.4	116.0	120.9	125.7	135.4	145.0
35	TC	61.6	57.9	56.0	54.0	49.9	45.5
	kW	4.3	4.9	5.2	5.6	6.4	7.4
	SDT	108.1	117.6	122.4	127.1	136.7	146.2
40	TC	67.7	63.7	61.6	59.5	55.1	50.5
	kW	4.3	4.9	5.3	5.6	6.5	7.4
	SDT	109.7	119.1	123.9	128.6	138.0	147.3
45	TC	74.3	69.9	67.7	65.4	60.7	55.8
	kW	4.4	5.0	5.3	5.7	6.5	7.4
	SDT	111.5	120.8	125.5	130.2	139.4	148.5
50	TC	81.3	76.6	74.2	71.8	66.8	61.6
	kW	4.5	5.1	5.4	5.8	6.6	7.5
	SDT	113.4	122.6	127.2	131.8	140.8	149.7

38AUZD08 Total Unit — Condenser Only Ratings — 60 Hz

SST (°F)		38AUZD08					
		Air Temperature Entering Condenser (°F)					
		85	95	100	105	115	125
20	TC	60.3	56.3	54.2	52.1	47.7	43.2
	kW	5.4	6.0	6.4	6.8	7.6	8.5
	SDT	99.4	108.5	113.0	117.5	126.4	135.2
25	TC	67.0	62.6	60.3	57.9	53.1	48.1
	kW	5.5	6.1	6.5	6.9	7.7	8.6
	SDT	100.8	109.8	114.2	118.7	127.5	136.2
30	TC	74.2	69.3	66.8	64.2	58.9	53.4
	kW	5.6	6.2	6.6	7.0	7.8	8.7
	SDT	102.3	111.2	115.6	120.0	128.7	137.3
35	TC	81.8	76.5	73.7	70.9	65.1	59.0
	kW	5.7	6.3	6.7	7.1	7.9	8.8
	SDT	103.9	112.7	117.0	121.4	130.0	138.4
40	TC	90.0	84.1	81.1	78.0	71.7	65.0
	kW	5.8	6.5	6.8	7.2	8.0	9.0
	SDT	105.6	114.2	118.5	122.8	131.3	139.6
45	TC	98.6	92.2	88.9	85.6	78.6	71.3
	kW	5.9	6.6	7.0	7.3	8.2	9.1
	SDT	107.4	115.9	120.1	124.3	132.7	140.8
50	TC	107.8	100.8	97.2	93.5	86.0	78.1
	kW	6.1	6.7	7.1	7.5	8.3	9.2
	SDT	109.2	117.6	121.8	125.9	134.1	142.1

LEGEND

- kW — Compressor Motor Power Input
- SDT — Saturated Discharge Temperature (°F)
- SST — Saturated Suction Temperature
- TC — Total Capacity (1000 Btuh) gross

38AUZM12 Total Unit — Condenser Only Ratings — 60 Hz

SST (°F)		38AUZM12					
		Air Temperature Entering Condenser (°F)					
		85	95	100	105	115	125
20	TC	75.6	69.3	66.1	63.0	57.1	52.0
	kW	7.2	8.0	8.4	8.9	10.0	11.1
	SDT	106.0	114.6	118.8	123.0	131.6	140.1
25	TC	84.0	77.3	73.9	70.5	64.1	58.3
	kW	7.3	8.1	8.6	9.0	10.1	11.2
	SDT	108.0	116.4	120.6	124.8	133.2	141.6
30	TC	92.8	85.8	82.1	78.5	71.4	65.0
	kW	7.5	8.3	8.7	9.2	10.2	11.3
	SDT	110.0	118.4	122.5	126.6	134.9	143.0
35	TC	102.2	94.7	90.8	86.9	79.2	72.0
	kW	7.7	8.5	8.9	9.4	10.4	11.5
	SDT	112.1	120.4	124.5	128.5	136.6	144.5
40	TC	112.1	104.0	99.8	95.6	87.3	79.3
	kW	7.9	8.7	9.1	9.5	10.5	11.6
	SDT	114.3	122.4	126.4	130.4	138.3	146.0
45	TC	122.5	113.8	109.3	104.8	95.8	87.0
	kW	8.1	8.9	9.3	9.8	10.7	11.8
	SDT	116.6	124.6	128.5	132.4	140.1	147.6
50	TC	133.4	124.0	119.2	114.3	104.5	94.9
	kW	8.3	9.1	9.5	10.0	10.9	11.9
	SDT	118.9	126.7	130.6	134.4	141.8	149.1

38AUDT12 Circuit A and B Unit — Condenser Only Ratings — 60 Hz

SST (°F)		38AUDT12 Total Unit					
		Air Temperature Entering Condenser (°F)					
		85	95	100	105	115	125
20	TC	76.8	71.7	69.1	66.4	60.9	55.2
	kW	6.9	7.7	8.2	8.7	9.8	11.0
	SDT	100.8	109.8	114.3	118.8	127.5	136.3
25	TC	84.9	79.5	76.7	73.8	67.8	61.6
	kW	7.0	7.9	8.4	8.9	9.9	11.1
	SDT	102.5	111.4	115.8	120.2	129.0	137.5
30	TC	93.7	87.8	84.7	81.6	75.2	68.5
	kW	7.2	8.0	8.5	9.0	10.1	11.3
	SDT	104.2	113.0	117.4	121.8	130.4	138.9
35	TC	103.0	96.6	93.2	89.8	82.8	75.5
	kW	7.3	8.2	8.7	9.2	10.3	11.4
	SDT	106.1	114.8	119.1	123.3	131.8	140.1
40	TC	113.0	105.9	102.3	98.6	90.9	83.0
	kW	7.5	8.4	8.9	9.4	10.4	11.6
	SDT	108.1	116.6	120.9	125.1	133.4	141.5
45	TC	123.5	115.7	111.8	107.8	99.6	90.9
	kW	7.7	8.6	9.0	9.6	10.6	11.8
	SDT	110.2	118.6	122.8	126.9	135.2	143.1
50	TC	134.5	126.0	121.7	117.4	108.1	98.7
	kW	7.9	8.8	9.2	9.8	10.8	12.0
	SDT	112.4	120.6	124.7	128.8	136.7	144.5

LEGEND

kW — Compressor Motor Power Input
SDT — Saturated Discharge Temperature (°F)
SST — Saturated Suction Temperature
TC — Total Capacity (1000 Btuh) gross

38AUZM14 Total Unit — Condenser Only Ratings — 60 Hz

SST (°F)		38AUZM14					
		Air Temperature Entering Condenser (°F)					
		85	95	100	105	115	125
20	TC	88.6	81.9	78.4	74.8	67.3	59.4
	kW	8.3	9.4	10.0	10.6	11.9	13.3
	SDT	103.8	112.6	116.9	121.2	129.6	137.7
25	TC	98.7	91.6	87.9	84.1	76.2	67.8
	kW	8.4	9.6	10.2	10.8	12.2	13.6
	SDT	105.8	114.5	118.8	123.0	131.3	139.4
30	TC	109.4	101.9	98.0	93.9	85.5	76.6
	kW	8.6	9.8	10.4	11.1	12.4	13.8
	SDT	107.9	116.5	120.8	124.9	133.1	141.0
35	TC	120.8	112.8	108.6	104.3	95.3	85.9
	kW	8.8	10.0	10.6	11.3	12.7	14.1
	SDT	110.2	118.7	122.8	126.9	135.0	142.7
40	TC	132.9	124.3	119.8	115.2	105.6	95.5
	kW	9.1	10.3	10.9	11.5	12.9	14.3
	SDT	112.5	120.9	125.0	129.1	136.9	144.5
45	TC	145.6	136.4	131.6	126.6	116.4	105.6
	kW	9.4	10.5	11.2	11.8	13.2	14.6
	SDT	115.0	123.2	127.3	131.2	138.9	146.3
50	TC	158.9	149.0	143.8	138.5	127.5	116.0
	kW	9.7	10.8	11.5	12.1	13.5	14.9
	SDT	117.6	125.6	129.6	133.5	141.0	148.1

38AUDT14 Circuit A and B Unit — Condenser Only Ratings — 60 Hz

SST (°F)		38AUDT14 Total Unit					
		Air Temperature Entering Condenser (°F)					
		85	95	100	105	115	125
20	TC	88.2	82.0	78.7	75.1	68.0	60.4
	kW	8.4	9.6	10.2	10.9	12.3	13.9
	SDT	101.5	110.5	115.0	119.4	128.1	136.6
25	TC	98.0	91.2	87.7	84.0	76.5	68.4
	kW	8.5	9.7	10.3	11.0	12.5	14.1
	SDT	103.2	112.1	116.5	120.9	129.5	137.9
30	TC	108.3	101.1	97.3	93.5	85.4	76.8
	kW	8.7	9.8	10.5	11.2	12.6	14.2
	SDT	104.9	113.8	118.2	122.5	131.0	139.3
35	TC	119.4	111.6	107.5	103.4	94.9	85.9
	kW	8.8	10.0	10.6	11.3	12.8	14.4
	SDT	106.8	115.5	119.9	124.2	132.6	140.8
40	TC	131.1	122.8	118.4	114.0	105.0	95.1
	kW	9.0	10.2	10.8	11.5	13.0	14.5
	SDT	108.7	117.4	121.7	125.9	134.2	142.2
45	TC	143.6	134.6	129.8	125.1	115.4	104.7
	kW	9.2	10.4	11.0	11.7	13.1	14.7
	SDT	110.8	119.3	123.5	127.7	135.9	143.7
50	TC	156.5	146.8	141.8	136.6	126.1	114.8
	kW	9.4	10.6	11.2	11.9	13.3	14.9
	SDT	112.9	121.3	125.5	129.5	137.6	145.2

LEGEND

kW — Compressor Motor Power Input
SDT — Saturated Discharge Temperature (°F)
SST — Saturated Suction Temperature
TC — Total Capacity (1000 Btuh) gross

38AUZA16 Total Unit — Condenser Only Ratings — 60 Hz

SST (°F)		38AUZA16					
		Air Temperature Entering Condenser (°F)					
		80	85	95	105	115	125
20	TC	125.5	121.8	114.2	106.6	99.7	79.7
	kW	10.5	11.2	12.6	14.2	16.0	17.5
	SDT	98.6	103.4	113.0	122.7	134.9	136.0
25	TC	138.7	134.7	126.5	118.1	109.3	98.5
	kW	10.7	11.4	12.8	14.3	16.0	17.9
	SDT	100.0	104.7	114.2	123.6	132.9	140.5
30	TC	152.9	148.6	139.8	130.7	120.9	104.9
	kW	10.9	11.6	13.0	14.6	16.2	17.8
	SDT	101.4	106.2	115.5	125.0	133.6	139.4
35	TC	168.2	163.5	154.1	144.2	133.6	121.2
	kW	11.2	11.8	13.2	14.8	16.5	18.1
	SDT	102.9	107.5	117.0	126.2	134.8	142.1
40	TC	184.9	179.4	169.3	158.7	147.6	135.1
	kW	11.5	12.0	13.5	15.1	16.8	18.5
	SDT	105.2	108.9	118.5	127.7	136.7	144.5
45	TC	202.1	196.7	185.7	174.3	162.5	150.4
	kW	11.7	12.4	13.9	15.6	17.5	19.6
	SDT	106.4	111.2	120.9	130.7	140.4	150.2
50	TC	220.6	214.7	202.1	190.0	174.6	159.6
	kW	11.9	12.6	13.9	15.4	16.9	18.5
	SDT	107.2	111.7	120.4	129.4	136.9	144.9

38AUDT16 Circuit A and B Unit — Condenser Only Ratings — 60 Hz

SST (°F)		38AUDT16 Total Unit					
		Air Temperature Entering Condenser (°F)					
		85	95	100	105	115	125
20	TC	126.1	118.2	114.1	110.0	101.6	93.1
	kW	11.2	12.5	13.3	14.1	15.8	17.7
	SDT	102.2	111.3	115.9	120.4	129.4	138.3
25	TC	138.7	130.1	125.7	121.3	112.1	102.8
	kW	11.4	12.8	13.5	14.3	16.0	18.0
	SDT	103.9	113.0	117.5	122.0	130.9	139.6
30	TC	152.3	143.0	138.2	133.3	123.4	113.2
	kW	11.7	13.1	13.8	14.6	16.3	18.3
	SDT	105.7	114.7	119.2	123.6	132.4	141.0
35	TC	166.9	156.7	151.5	146.2	135.3	124.3
	kW	12.0	13.4	14.1	14.9	16.7	18.6
	SDT	107.6	116.5	120.9	125.3	134.0	142.5
40	TC	182.4	171.3	165.6	159.9	148.1	136.0
	kW	12.3	13.7	14.5	15.3	17.0	18.9
	SDT	109.7	118.5	122.8	127.2	135.7	144.1
45	TC	199.0	186.9	180.7	174.4	161.6	148.4
	kW	12.7	14.1	14.8	15.6	17.4	19.3
	SDT	111.8	120.5	124.8	129.1	137.5	145.7
50	TC	216.6	203.3	196.6	189.7	175.7	161.3
	kW	13.1	14.5	15.2	16.1	17.8	19.7
	SDT	114.1	122.7	126.9	131.2	139.4	147.3

LEGEND

- kW — Compressor Motor Power Input
- SDT — Saturated Discharge Temperature (°F)
- SST — Saturated Suction Temperature
- TC — Total Capacity (1000 Btuh) gross

38AUZA25 Total Unit — Condenser Only Ratings — 60 Hz

SST (°F)		38AUZA25					
		Air Temperature Entering Condenser (°F)					
		80	85	95	105	115	125
20	TC	159.2	154.5	144.5	133.9	122.5	110.2
	kW	13.0	13.7	15.3	17.1	19.2	21.5
	SDT	97.3	101.8	110.6	119.3	127.9	136.5
25	TC	176.1	171.0	160.2	148.8	136.5	123.2
	kW	13.2	14.0	15.6	17.4	19.5	21.8
	SDT	98.9	103.3	112.0	120.7	129.2	137.6
30	TC	194.2	188.6	176.9	164.5	151.3	136.9
	kW	13.5	14.3	15.9	17.7	19.7	22.0
	SDT	100.6	104.9	113.6	122.1	130.5	138.8
35	TC	213.5	207.4	194.7	181.2	166.8	151.2
	kW	13.8	14.6	16.2	18.0	20.0	22.3
	SDT	102.4	106.7	115.2	123.6	131.9	140.1
40	TC	234.1	227.4	213.5	198.8	183.1	166.1
	kW	14.2	14.9	16.5	18.3	20.3	22.6
	SDT	104.3	108.5	116.9	125.2	133.3	141.4
45	TC	255.9	248.6	233.3	217.3	200.1	181.7
	kW	14.6	15.3	16.9	18.7	20.7	22.9
	SDT	106.3	110.5	118.7	126.8	134.9	142.7
50	TC	279.0	270.9	254.2	236.7	218.1	197.8
	kW	15.1	15.8	17.3	19.1	21.1	23.2
	SDT	108.5	112.5	120.6	128.6	136.5	144.1

38AUDT25 Circuit A and B Unit — Condenser Only Ratings — 60 Hz

SST (°F)		38AUDT25 Total Unit					
		Air Temperature Entering Condenser (°F)					
		85	95	100	105	115	125
20	TC	161.4	150.4	144.6	138.7	127.0	115.4
	kW	13.6	15.2	16.0	16.9	18.9	21.1
	SDT	100.8	109.7	114.1	118.4	127.2	135.9
25	TC	178.1	166.4	160.2	153.9	141.1	128.4
	kW	13.9	15.5	16.3	17.2	19.1	21.3
	SDT	102.5	111.3	115.6	119.9	128.5	137.1
30	TC	195.8	183.2	176.5	169.7	155.8	141.9
	kW	14.2	15.8	16.6	17.5	19.4	21.6
	SDT	104.2	112.8	117.2	121.5	130.0	138.4
35	TC	214.5	200.8	193.6	186.3	171.2	155.9
	kW	14.6	16.1	16.9	17.8	19.7	21.9
	SDT	106.1	114.6	118.9	123.1	131.5	139.7
40	TC	233.9	219.3	211.5	203.5	187.1	170.3
	kW	14.9	16.5	17.3	18.2	20.1	22.2
	SDT	108.0	116.5	120.7	124.8	133.1	141.1
45	TC	254.5	238.5	230.0	221.3	203.4	184.9
	kW	15.4	16.9	17.7	18.6	20.5	22.5
	SDT	110.1	118.4	122.6	126.6	134.7	142.6
50	TC	275.8	258.3	249.0	239.5	219.8	199.4
	kW	15.8	17.3	18.2	19.0	20.9	22.9
	SDT	112.3	120.5	124.5	128.5	136.4	144.0

LEGEND

kW — Compressor Motor Power Input
SDT — Saturated Discharge Temperature (°F)
SST — Saturated Suction Temperature
TC — Total Capacity (1000 Btuh) gross

38AUDT28 Circuit A and B Unit — Condenser Only Ratings — 60 Hz

SST (°F)		38AUDT28 Total Unit					
		Air Temperature Entering Condenser (°F)					
		85	95	100	105	115	125
20	TC	193.2	180.1	173.1	165.9	150.5	134.0
	kW	17.6	19.5	20.5	21.6	24.0	26.6
	SDT	104.0	112.6	116.9	121.2	129.6	137.7
25	TC	212.9	198.9	191.5	183.8	167.6	150.3
	kW	18.0	19.9	21.0	22.1	24.5	27.1
	SDT	106.0	114.5	118.8	123.0	131.3	139.3
30	TC	233.6	218.6	210.7	202.5	185.3	166.9
	kW	18.5	20.4	21.5	22.6	25.0	27.6
	SDT	108.1	116.5	120.7	124.9	133.0	140.9
35	TC	255.4	239.1	230.6	221.8	203.3	183.7
	kW	19.0	21.0	22.1	23.2	25.6	28.2
	SDT	110.3	118.6	122.7	126.8	134.8	142.6
40	TC	278.0	260.3	251.1	241.5	221.7	200.6
	kW	19.6	21.6	22.6	23.8	26.2	28.8
	SDT	112.7	120.8	124.9	128.8	136.7	144.2
45	TC	301.4	282.0	271.9	261.6	240.0	217.2
	kW	20.2	22.2	23.3	24.4	26.8	29.4
	SDT	115.1	123.1	127.0	130.9	138.6	145.9
50	TC	325.3	304.0	292.9	281.6	258.1	233.3
	kW	20.9	22.9	23.9	25.1	27.4	30.0
	SDT	117.7	125.4	129.3	133.1	140.5	147.6

LEGEND

- kW — Compressor Motor Power Input
- SDT — Saturated Discharge Temperature (°F)
- SST — Saturated Suction Temperature
- TC — Total Capacity (1000 Btuh) gross



38AUZ07/40RFA07 Stage 2 Combination Ratings — 60 Hz

38AUZ07/40RFA07			AMBIENT TEMPERATURE (°F)																
			85			95			105			115			125				
			EA (db)			EA (db)			EA (db)			EA (db)			EA (db)				
			75	80	85	75	80	85	75	80	85	75	80	85	75	80	85		
1800 cfm	EA (wb)	58	TC	61.4	61.4	67.0	58.8	58.8	66.4	57.3	57.3	61.7	54.2	54.2	61.2	51.5	51.5	58.3	
			SHC	52.1	59.5	67.0	51.1	58.8	66.4	48.1	54.9	61.7	47.1	54.2	61.2	44.8	51.5	58.3	
		62	TC	64.9	64.9	64.9	62.3	62.3	62.3	59.4	59.4	60.4	56.3	56.3	58.9	52.9	52.9	57.1	
			SHC	46.8	54.9	62.9	45.5	53.6	61.7	44.2	52.3	60.4	42.8	50.8	58.9	41.1	49.1	57.1	
		67	TC	70.7	70.7	70.7	67.8	67.8	67.8	64.7	64.7	64.7	61.4	61.4	61.4	57.8	57.8	57.8	
			SHC	38.4	46.4	54.3	37.2	45.2	53.2	35.9	43.9	51.9	34.6	42.6	50.7	33.1	41.1	49.2	
	72	TC	77.3	77.3	77.3	74.3	74.3	74.3	70.9	70.9	70.9	67.1	67.1	67.1	63.2	63.2	63.2		
		SHC	30.5	38.0	45.5	29.2	36.9	44.6	27.9	35.6	43.4	26.4	34.3	42.2	25.0	32.9	40.9		
	76	TC	—	83.3	83.3	—	79.6	79.6	—	76.1	76.1	—	72.2	72.2	—	67.9	67.9		
		SHC	—	31.0	40.9	—	29.9	39.8	—	28.5	38.4	—	27.5	37.4	—	26.2	33.7		
	2100 cfm	EA (wb)	58	TC	65.3	65.3	68.4	61.8	61.8	69.8	59.3	59.3	67.0	56.7	56.7	64.1	53.8	53.8	60.9
				SHC	53.8	61.1	68.4	53.7	61.8	69.8	51.6	59.3	67.0	49.3	56.7	64.1	46.8	53.8	60.9
62			TC	66.8	66.8	68.4	64.0	64.0	67.0	61.0	61.0	65.5	57.8	57.8	63.7	54.5	54.5	61.6	
			SHC	50.0	59.2	68.4	48.6	57.8	67.0	47.2	56.3	65.5	45.6	54.7	63.7	43.8	52.7	61.6	
67			TC	72.5	72.5	72.5	69.6	69.6	69.6	66.4	66.4	66.4	63.0	63.0	63.0	59.2	59.2	59.2	
			SHC	40.4	49.5	58.6	39.2	48.3	57.5	37.9	47.1	56.3	36.5	45.7	54.9	35.0	44.3	53.5	
72		TC	79.3	79.3	79.3	75.9	75.9	75.9	72.4	72.4	72.4	68.7	68.7	68.7	64.6	64.6	64.6		
		SHC	31.1	39.9	48.7	29.9	38.8	47.7	28.5	37.5	46.6	27.1	36.2	45.3	25.6	34.8	43.9		
76		TC	—	85.3	85.3	—	81.7	81.7	—	77.7	77.7	—	73.7	73.7	—	69.1	69.1		
		SHC	—	31.8	43.4	—	30.9	42.5	—	29.7	37.7	—	28.5	37.1	—	27.1	36.1		
2400 cfm		EA (wb)	58	TC	66.4	66.4	75.1	64.1	64.1	72.4	61.5	61.5	69.5	58.8	58.8	66.4	55.8	55.8	63.1
				SHC	57.8	66.4	75.1	55.7	64.1	72.4	53.5	61.5	69.5	51.1	58.8	66.4	48.6	55.8	63.1
	62		TC	68.3	68.3	73.3	65.4	65.4	71.8	62.4	62.4	69.9	59.1	59.1	67.5	56.3	56.3	64.1	
			SHC	52.8	63.1	73.3	51.4	61.6	71.8	49.8	59.9	69.9	47.8	57.6	67.5	45.4	54.7	64.1	
	67		TC	74.1	74.1	74.1	71.0	71.0	71.0	67.7	67.7	67.7	64.1	64.1	64.1	60.2	60.2	60.2	
			SHC	42.3	52.5	62.7	41.0	51.3	61.5	39.8	50.0	60.3	38.3	48.5	58.8	36.9	47.2	57.5	
	72	TC	80.8	80.8	80.8	77.3	77.3	77.3	73.8	73.8	73.8	69.9	69.9	69.9	65.7	65.7	65.7		
		SHC	31.7	41.8	51.8	30.5	40.6	50.7	29.1	39.3	49.5	27.7	37.9	48.1	26.2	36.5	46.7		
	76	TC	—	86.7	86.7	—	83.0	83.0	—	79.0	79.0	—	74.7	74.7	—	70.1	70.1		
		SHC	—	33.0	41.4	—	31.9	41.2	—	30.6	40.3	—	29.3	39.3	—	27.9	38.1		
	2700 cfm	EA (wb)	58	TC	68.5	68.5	77.4	66.0	66.0	74.6	63.3	63.3	71.6	60.5	60.5	68.4	57.5	57.5	65.0
				SHC	59.6	68.5	77.4	57.4	66.0	74.6	55.1	63.3	71.6	52.7	60.5	68.4	50.0	57.5	65.0
62			TC	69.6	69.6	77.6	66.8	66.8	75.6	63.6	63.6	73.6	60.6	60.6	71.0	57.8	57.8	66.3	
			SHC	55.4	66.5	77.6	53.7	64.6	75.6	52.0	62.8	73.6	50.0	60.5	71.0	47.0	56.6	66.3	
67			TC	75.3	75.3	75.3	72.1	72.1	72.1	68.8	68.8	68.8	65.1	65.1	65.1	61.1	61.1	61.3	
			SHC	44.0	55.3	66.6	42.8	54.1	65.5	41.5	52.9	64.2	40.1	51.5	62.8	38.6	49.9	61.3	
72		TC	82.2	82.2	82.2	78.6	78.6	78.6	74.8	74.8	74.8	70.8	70.8	70.8	66.5	66.5	66.5		
		SHC	32.3	43.5	54.6	31.0	42.2	53.5	29.7	41.0	52.2	28.3	39.6	50.9	26.8	38.1	49.4		
76		TC	—	88.1	88.1	—	84.1	84.1	—	80.0	80.0	—	75.6	75.6	—	70.9	70.9		
		SHC	—	33.9	44.3	—	32.6	43.4	—	31.4	42.4	—	30.0	41.2	—	28.6	39.9		
3000 cfm		EA (wb)	58	TC	70.3	70.3	79.4	67.8	67.8	76.6	65.0	65.0	73.4	62.1	62.1	70.2	58.9	58.9	66.6
				SHC	61.2	70.3	79.4	59.0	67.8	76.6	56.5	65.0	73.4	54.0	62.1	70.2	51.3	58.9	66.6
	62		TC	70.9	70.9	80.6	67.8	67.8	79.6	65.0	65.0	76.3	62.2	62.2	72.4	59.6	59.6	66.0	
			SHC	57.3	69.0	80.6	56.1	67.8	79.6	53.7	65.0	76.3	51.1	61.7	72.4	47.2	56.6	66.0	
	67		TC	76.4	76.4	76.4	73.1	73.1	73.1	69.6	69.6	69.6	65.9	65.9	66.5	61.8	61.8	64.8	
			SHC	45.7	58.1	70.4	44.5	56.9	69.2	43.2	55.6	68.0	41.8	54.1	66.5	40.2	52.5	64.8	
	72	TC	83.1	83.1	83.1	79.5	79.5	79.5	75.7	75.7	75.7	71.6	71.6	71.6	67.2	67.2	67.2		
		SHC	32.8	45.0	57.3	31.5	43.8	56.1	30.2	42.5	54.8	28.8	41.1	53.4	27.3	39.6	51.9		
	76	TC	—	88.9	88.9	—	85.0	85.0	—	80.8	80.8	—	76.4	76.4	—	71.5	71.5		
		SHC	—	34.5	46.2	—	33.3	45.3	—	32.0	44.2	—	30.7	43.0	—	29.2	41.6		

LEGEND

- db — dry bulb
- EA — Entering Air Temperature (°F)
- SHC — Sensible Heat Capacity (1000 Btuh) gross
- TC — Total Capacity (1000 Btuh) gross
- wb — wet bulb

38AUZ07/40RFA07 Stage 1 Combination Ratings — 60 Hz

38AUZ07/40RFA07			AMBIENT TEMPERATURE (°F)															
			85			95			105			115			125			
			EA (db)			EA (db)			EA (db)			EA (db)			EA (db)			
			75	80	85	75	80	85	75	80	85	75	80	85	75	80	85	
1500 cfm	EA (wb)	58	TC	47.0	47.0	53.1	45.4	45.4	51.3	43.5	43.5	49.2	41.4	41.4	46.7	39.0	39.0	44.0
			SHC	41.0	47.0	53.1	39.5	45.4	51.3	37.9	43.5	49.2	36.0	41.4	46.7	33.9	39.0	44.0
		62	TC	49.4	49.4	50.7	47.3	47.3	49.6	44.9	44.9	48.4	42.2	42.2	47.0	39.4	39.4	45.0
			SHC	37.1	43.9	50.7	36.1	42.8	49.6	34.9	41.7	48.4	33.6	40.3	47.0	31.9	38.5	45.0
		67	TC	54.4	54.4	54.4	52.1	52.1	52.1	49.4	49.4	49.4	46.5	46.5	46.5	43.2	43.2	43.2
	SHC		30.4	37.0	43.7	29.4	36.1	42.8	28.3	35.1	41.8	27.1	33.9	40.6	25.8	32.6	39.4	
	72	TC	60.0	60.0	60.0	57.4	57.4	57.4	54.4	54.4	54.4	51.2	51.2	51.2	47.7	47.7	47.7	
		SHC	23.9	30.3	36.7	22.8	29.3	35.8	21.7	28.3	34.9	20.5	27.1	33.8	19.2	25.9	32.5	
	76	TC	—	64.9	64.9	—	61.9	61.9	—	58.7	58.7	—	55.3	55.3	—	51.4	51.4	
		SHC	—	24.4	32.6	—	23.6	31.8	—	22.7	30.9	—	21.6	27.7	—	20.4	26.9	
1800 cfm	EA (wb)	58	TC	49.9	49.9	56.4	48.2	48.2	54.4	46.1	46.1	52.1	43.8	43.8	49.5	41.2	41.2	46.5
			SHC	43.4	49.9	56.4	41.9	48.2	54.4	40.1	46.1	52.1	38.1	43.8	49.5	35.9	41.2	46.5
		62	TC	51.2	51.2	56.0	49.0	49.0	54.7	46.6	46.6	53.0	44.2	44.2	50.5	41.4	41.4	47.4
			SHC	40.2	48.1	56.0	39.1	46.9	54.7	37.7	45.3	53.0	35.8	43.2	50.5	33.6	40.5	47.4
		67	TC	56.2	56.2	56.2	53.7	53.7	53.7	50.9	50.9	50.9	47.8	47.8	47.8	44.4	44.4	44.4
	SHC		32.4	40.3	48.1	31.4	39.3	47.1	30.3	38.2	46.1	29.1	37.0	44.9	27.8	35.7	43.6	
	72	TC	61.7	61.7	61.7	59.0	59.0	59.0	56.0	56.0	56.0	52.5	52.5	52.5	48.8	48.8	48.8	
		SHC	24.6	32.2	39.9	23.5	31.3	39.0	22.4	30.2	38.0	21.2	29.0	36.8	19.9	27.7	35.5	
	76	TC	—	66.5	66.5	—	63.5	63.5	—	60.2	60.2	—	56.5	56.5	—	52.5	52.5	
		SHC	—	25.6	31.9	—	24.7	31.7	—	23.7	31.1	—	22.6	30.2	—	21.3	29.1	
2100 cfm	EA (wb)	58	TC	52.2	52.2	59.0	50.3	50.3	56.9	48.2	48.2	54.5	45.7	45.7	51.6	42.9	42.9	48.5
			SHC	45.5	52.2	59.0	43.8	50.3	56.9	42.0	48.2	54.5	39.8	45.7	51.6	37.4	42.9	48.5
		62	TC	52.8	52.8	60.1	50.4	50.4	59.1	48.8	48.8	55.2	46.2	46.2	52.3	43.0	43.0	50.4
			SHC	42.7	51.4	60.1	41.7	50.4	59.1	39.3	47.3	55.2	37.2	44.7	52.3	35.5	43.0	50.4
		67	TC	57.5	57.5	57.5	54.9	54.9	54.9	52.0	52.0	52.0	48.8	48.8	48.8	45.3	45.3	47.5
	SHC		34.2	43.2	52.1	33.2	42.2	51.2	32.1	41.1	50.1	30.9	39.8	48.8	29.5	38.5	47.5	
	72	TC	63.0	63.0	63.0	60.2	60.2	60.2	57.0	57.0	57.0	53.5	53.5	53.5	49.7	49.7	49.7	
		SHC	25.2	34.0	42.8	24.1	33.0	41.9	23.0	31.9	40.8	21.8	30.7	39.6	20.5	29.4	38.3	
	76	TC	—	67.8	67.8	—	64.7	64.7	—	61.3	61.3	—	57.5	57.5	—	53.3	53.3	
		SHC	—	26.5	34.8	—	25.6	34.1	—	24.5	33.2	—	23.4	32.2	—	22.1	31.0	
2400 cfm	EA (wb)	58	TC	54.2	54.2	61.2	52.2	52.2	58.9	49.9	49.9	56.4	47.3	47.3	53.4	44.4	44.4	50.1
			SHC	47.2	54.2	61.2	45.4	52.2	58.9	43.4	49.9	56.4	41.1	47.3	53.4	38.6	44.4	50.1
		62	TC	54.2	54.2	63.6	52.4	52.4	60.6	50.5	50.5	56.5	47.3	47.3	55.5	44.4	44.4	52.0
			SHC	44.8	54.2	63.6	42.9	51.8	60.6	40.3	48.4	56.5	39.1	47.3	55.5	36.7	44.4	52.0
		67	TC	58.5	58.5	58.5	55.9	55.9	55.9	52.9	52.9	53.9	49.6	49.6	52.6	45.9	45.9	51.0
	SHC		36.0	46.0	56.0	35.0	45.0	55.1	33.8	43.8	53.9	32.6	42.6	52.6	31.1	41.1	51.0	
	72	TC	64.0	64.0	64.0	61.1	61.1	61.1	57.8	57.8	57.8	54.3	54.3	54.3	50.3	50.3	50.3	
		SHC	25.7	35.7	45.6	24.7	34.6	44.6	23.6	33.5	43.5	22.3	32.3	42.3	21.0	31.0	40.9	
	76	TC	—	68.8	68.8	—	65.6	65.6	—	62.1	62.1	—	58.2	58.2	—	53.9	53.9	
		SHC	—	27.3	36.8	—	26.3	36.0	—	25.3	35.1	—	24.0	34.0	—	22.7	32.7	
2700 cfm	EA (wb)	58	TC	55.8	55.8	63.0	53.7	53.7	60.6	51.3	51.3	57.9	48.5	48.5	54.8	45.5	45.5	51.3
			SHC	48.5	55.8	63.0	46.7	53.7	60.6	44.6	51.3	57.9	42.2	48.5	54.8	39.6	45.5	51.3
		62	TC	55.8	55.8	65.5	54.3	54.3	61.1	51.3	51.3	60.2	48.6	48.6	57.0	45.5	45.5	53.4
			SHC	46.2	55.8	65.5	43.5	52.3	61.1	42.4	51.3	60.2	40.2	48.6	57.0	37.6	45.5	53.4
		67	TC	59.4	59.4	59.7	56.7	56.7	58.6	53.6	53.6	57.6	50.1	50.1	56.0	46.5	46.5	54.2
	SHC		37.6	48.7	59.7	36.6	47.6	58.6	35.5	46.5	57.6	34.1	45.0	56.0	32.6	43.4	54.2	
	72	TC	64.9	64.9	64.9	61.8	61.8	61.8	58.6	58.6	58.6	54.9	54.9	54.9	50.9	50.9	50.9	
		SHC	26.2	37.2	48.1	25.2	36.1	47.1	24.1	35.0	46.0	22.8	33.8	44.8	21.5	32.4	43.4	
	76	TC	—	69.5	69.5	—	66.3	66.3	—	62.7	62.7	—	58.8	58.8	—	54.3	54.3	
		SHC	—	27.9	38.6	—	27.0	37.8	—	25.8	36.8	—	24.6	35.6	—	23.3	34.3	

LEGEND

- db — dry bulb
- EA — Entering Air Temperature (°F)
- SHC — Sensible Heat Capacity (1000 Btuh) gross
- TC — Total Capacity (1000 Btuh) gross
- wb — wet bulb

38AUZ08/40RFA08 Stage 2 Combination Ratings — 60 Hz

38AUZ08/40RFA08			AMBIENT TEMPERATURE (°F)																
			85			95			105			115			125				
			EA (db)			EA (db)			EA (db)			EA (db)			EA (db)				
			75	80	85	75	80	85	75	80	85	75	80	85	75	80	85		
2250 cfm	EA (wb)	58	TC	81.8	81.8	88.9	77.8	77.8	88.1	74.6	74.6	84.5	71.2	71.2	80.7	67.3	67.3	76.3	
			SHC	68.8	78.9	88.9	67.5	77.8	88.1	64.7	74.6	84.5	61.8	71.2	80.7	58.4	67.3	76.3	
		62	TC	86.3	86.3	86.3	82.9	82.9	82.9	78.3	78.3	80.2	74.3	74.3	78.1	69.1	69.1	75.9	
			SHC	61.9	72.9	83.9	60.0	70.8	81.5	58.1	69.2	80.2	56.2	67.2	78.1	54.0	64.9	75.9	
		67	TC	94.9	94.9	94.9	90.6	90.6	90.6	86.0	86.0	86.0	81.1	81.1	81.1	75.9	75.9	75.9	
			SHC	50.7	61.6	72.5	48.9	59.8	70.7	47.0	58.0	69.0	45.0	56.0	67.0	42.9	53.9	64.9	
	72	TC	104.3	104.3	104.3	99.8	99.8	99.8	94.6	94.6	94.6	89.3	89.3	89.3	83.3	83.3	83.3		
		SHC	39.8	50.2	60.6	38.0	48.5	59.1	35.9	46.6	57.3	33.9	44.7	55.5	31.7	42.6	53.4		
	76	TC	—	112.3	112.3	—	107.3	107.3	—	101.8	101.8	—	95.8	95.8	—	89.1	89.1		
		SHC	—	41.2	53.6	—	39.2	51.5	—	37.3	49.6	—	35.4	45.3	—	33.3	43.8		
	2625 cfm	EA (wb)	58	TC	85.6	85.6	96.9	82.4	82.4	93.3	78.9	78.9	89.3	75.1	75.1	85.0	71.0	71.0	80.4
				SHC	74.3	85.6	96.9	71.5	82.4	93.3	68.5	78.9	89.3	65.1	75.1	85.0	61.6	71.0	80.4
62			TC	89.4	89.4	92.4	87.6	87.6	87.6	80.9	80.9	88.3	76.3	76.3	85.8	71.4	71.4	82.4	
			SHC	66.9	79.7	92.4	63.3	74.7	86.1	63.0	75.6	88.3	60.7	73.2	85.8	58.0	70.2	82.4	
67			TC	98.2	98.2	98.2	93.5	93.5	93.5	88.8	88.8	88.8	83.4	83.4	83.4	77.9	77.9	77.9	
			SHC	53.9	66.6	79.2	52.1	64.7	77.4	50.2	62.9	75.6	48.1	60.8	73.5	45.9	58.6	71.3	
72		TC	107.5	107.5	107.5	102.7	102.7	102.7	97.2	97.2	97.2	91.5	91.5	91.5	85.3	85.3	85.3		
		SHC	40.9	53.2	65.5	39.1	51.5	63.9	37.0	49.5	62.0	35.0	47.5	60.0	32.7	45.3	57.8		
76		TC	—	115.6	115.6	—	110.1	110.1	—	104.2	104.2	—	97.5	97.5	—	91.0	91.0		
		SHC	—	42.3	56.8	—	40.6	51.5	—	38.7	50.5	—	36.6	48.8	—	34.5	46.9		
3000 cfm		EA (wb)	58	TC	89.1	89.1	100.8	85.7	85.7	97.0	81.9	81.9	92.7	78.1	78.1	88.4	73.7	73.7	83.4
				SHC	77.3	89.1	100.8	74.4	85.7	97.0	71.1	81.9	92.7	67.8	78.1	88.4	64.0	73.7	83.4
	62		TC	92.9	92.9	96.1	87.3	87.3	97.0	82.9	82.9	94.5	78.0	78.0	91.7	75.0	75.0	83.0	
			SHC	69.4	82.8	96.1	69.0	83.0	97.0	66.8	80.7	94.5	64.3	78.0	91.7	59.0	71.0	83.0	
	67		TC	100.2	100.2	100.2	95.7	95.7	95.7	90.5	90.5	90.5	85.2	85.2	85.2	79.3	79.3	79.3	
			SHC	56.5	70.7	84.8	54.7	68.9	83.1	52.7	66.8	81.0	50.6	64.8	79.0	48.4	62.5	76.7	
	72	TC	109.7	109.7	109.7	104.5	104.5	104.5	98.9	98.9	98.9	93.0	93.0	93.0	86.6	86.6	86.6		
		SHC	41.7	55.6	69.4	39.8	53.7	67.6	37.8	51.8	65.7	35.7	49.7	63.7	33.5	47.5	61.5		
	76	TC	—	117.4	117.4	—	111.8	111.8	—	105.7	105.7	—	99.1	99.1	—	91.8	91.8		
		SHC	—	43.4	56.1	—	41.6	54.8	—	39.7	53.2	—	37.6	51.3	—	35.3	49.1		
	3375 cfm	EA (wb)	58	TC	92.5	92.5	104.6	88.9	88.9	100.6	85.1	85.1	96.3	80.7	80.7	91.3	76.2	76.2	86.2
				SHC	80.4	92.5	104.6	77.3	88.9	100.6	73.9	85.1	96.3	70.1	80.7	91.3	66.2	76.2	86.2
62			TC	93.8	93.8	106.2	89.5	89.5	103.1	85.3	85.3	99.4	81.8	81.8	92.2	76.3	76.3	89.6	
			SHC	75.2	90.7	106.2	72.7	87.9	103.1	69.9	84.6	99.4	65.3	78.8	92.2	62.9	76.3	89.6	
67			TC	102.4	102.4	102.4	97.3	97.3	97.3	92.1	92.1	92.1	86.6	86.6	86.6	80.5	80.5	82.5	
			SHC	59.4	75.2	91.0	57.4	73.3	89.1	55.4	71.2	87.0	53.3	69.1	84.8	51.1	66.8	82.5	
72		TC	111.7	111.7	111.7	106.6	106.6	106.6	100.4	100.4	100.4	94.2	94.2	94.2	87.8	87.8	87.8		
		SHC	42.6	58.1	73.6	40.8	56.3	71.9	38.6	54.2	69.8	36.4	52.0	67.6	34.2	49.8	65.3		
76		TC	—	119.3	119.3	—	113.2	113.2	—	106.9	106.9	—	100.1	100.1	—	92.8	92.8		
		SHC	—	44.4	59.2	—	42.5	57.6	—	40.5	55.8	—	38.3	53.7	—	36.1	51.4		
3750 cfm		EA (wb)	58	TC	95.1	95.1	107.6	91.5	91.5	103.5	87.3	87.3	98.8	82.8	82.8	93.6	78.0	78.0	88.3
				SHC	82.7	95.1	107.6	79.5	91.5	103.5	75.9	87.3	98.8	71.9	82.8	93.6	67.8	78.0	88.3
	62		TC	96.5	96.5	108.5	91.5	91.5	107.5	90.1	90.1	94.0	82.9	82.9	97.2	78.1	78.1	91.7	
			SHC	77.0	92.8	108.5	75.5	91.5	107.5	68.0	81.0	94.0	68.3	82.8	97.2	64.4	78.1	91.7	
	67		TC	103.7	103.7	103.7	98.7	98.7	98.7	93.2	93.2	93.2	87.5	87.5	89.8	82.0	82.0	85.8	
			SHC	61.7	78.9	96.1	59.8	76.9	94.1	57.7	74.9	92.1	55.6	72.7	89.8	52.6	69.2	85.8	
	72	TC	113.0	113.0	113.0	107.4	107.4	107.4	101.6	101.6	101.6	95.3	95.3	95.3	88.6	88.6	88.6		
		SHC	43.2	60.1	77.0	41.2	58.2	75.2	39.2	56.2	73.1	37.1	54.0	70.9	34.8	51.7	68.6		
	76	TC	—	120.5	120.5	—	114.3	114.3	—	108.1	108.1	—	100.9	100.9	—	93.6	93.6		
		SHC	—	45.1	61.4	—	43.1	59.7	—	41.2	57.8	—	38.9	55.6	—	36.6	53.2		

LEGEND

- db — dry bulb
- EA — Entering Air Temperature (°F)
- SHC — Sensible Heat Capacity (1000 Btuh) gross
- TC — Total Capacity (1000 Btuh) gross
- wb — wet bulb

38AUZ08/40RFA08 Stage 1 Combination Ratings — 60 Hz

38AUZ08/40RFA08			AMBIENT TEMPERATURE (°F)																
			85			95			105			115			125				
			EA (db)			EA (db)			EA (db)			EA (db)			EA (db)				
			75	80	85	75	80	85	75	80	85	75	80	85	75	80	85		
1900 cfm	EA (wb)	58	TC	58.3	58.3	65.9	55.2	55.2	62.4	51.8	51.8	58.6	48.1	48.1	54.4	44.2	44.2	50.0	
			SHC	50.6	58.3	65.9	48.0	55.2	62.4	45.0	51.8	58.6	41.8	48.1	54.4	38.4	44.2	50.0	
		62	TC	60.1	60.1	65.1	56.1	56.1	63.1	52.1	52.1	60.0	48.7	48.7	55.1	44.2	44.2	52.0	
			SHC	46.7	55.9	65.1	44.8	53.9	63.1	42.3	51.2	60.0	39.0	47.0	55.1	36.5	44.2	52.0	
		67	TC	66.6	66.6	66.6	62.4	62.4	62.4	57.7	57.7	57.7	52.6	52.6	52.6	47.3	47.3	48.7	
			SHC	37.7	46.9	56.1	36.0	45.3	54.5	34.2	43.4	52.7	32.2	41.5	50.7	30.2	39.5	48.7	
	72	TC	73.6	73.6	73.6	69.2	69.2	69.2	64.2	64.2	64.2	58.8	58.8	58.8	53.1	53.1	53.1		
		SHC	28.5	37.5	46.5	26.9	35.9	45.0	25.1	34.2	43.2	23.2	32.3	41.4	21.2	30.4	39.5		
	76	TC	—	79.6	79.6	—	75.1	75.1	—	69.8	69.8	—	64.0	64.0	—	58.1	58.1		
		SHC	—	29.8	40.2	—	28.4	36.4	—	26.7	35.2	—	24.9	33.7	—	23.0	31.9		
	2250 cfm	EA (wb)	58	TC	61.8	61.8	69.9	58.5	58.5	66.2	54.8	54.8	62.0	50.9	50.9	57.5	46.6	46.6	52.8
				SHC	53.8	61.8	69.9	50.9	58.5	66.2	47.7	54.8	62.0	44.2	50.9	57.5	40.5	46.6	52.8
62			TC	62.4	62.4	71.4	58.9	58.9	67.7	54.1	54.1	64.2	50.9	50.9	59.8	46.7	46.7	54.8	
			SHC	50.5	61.0	71.4	47.8	57.8	67.7	43.9	54.1	64.2	42.0	50.9	59.8	38.5	46.7	54.8	
67			TC	68.6	68.6	68.6	64.2	64.2	64.2	59.3	59.3	59.3	54.0	54.0	56.4	48.5	48.5	54.2	
			SHC	40.4	51.1	61.9	38.7	49.4	60.2	36.8	47.6	58.4	34.9	45.6	56.4	32.8	43.5	54.2	
72		TC	75.6	75.6	75.6	71.0	71.0	71.0	65.9	65.9	65.9	60.2	60.2	60.2	54.3	54.3	54.3		
		SHC	29.5	40.0	50.5	27.9	38.4	49.0	26.0	36.7	47.3	24.1	34.8	45.4	22.1	32.8	43.4		
76		TC	—	81.6	81.6	—	76.9	76.9	—	71.4	71.4	—	65.5	65.5	—	59.2	59.2		
		SHC	—	31.1	40.8	—	29.6	39.6	—	27.9	38.1	—	26.0	36.4	—	24.1	34.5		
2650 cfm		EA (wb)	58	TC	65.0	65.0	73.5	61.5	61.5	69.5	57.6	57.6	65.1	53.3	53.3	60.3	48.8	48.8	55.2
				SHC	56.6	65.0	73.5	53.5	61.5	69.5	50.1	57.6	65.1	46.4	53.3	60.3	42.4	48.8	55.2
	62		TC	65.1	65.1	76.4	61.6	61.6	72.3	57.6	57.6	67.7	53.4	53.4	62.7	48.9	48.9	57.4	
			SHC	53.8	65.1	76.4	50.9	61.6	72.3	47.6	57.6	67.7	44.1	53.4	62.7	40.3	48.9	57.4	
	67		TC	70.3	70.3	70.3	65.7	65.7	66.4	60.7	60.7	64.4	55.2	55.2	62.3	49.6	49.6	59.6	
			SHC	43.2	55.7	68.1	41.5	54.0	66.4	39.7	52.0	64.4	37.6	50.0	62.3	35.4	47.5	59.6	
	72	TC	77.3	77.3	77.3	72.6	72.6	72.6	67.2	67.2	67.2	61.4	61.4	61.4	55.3	55.3	55.3		
		SHC	30.4	42.6	54.8	28.8	41.0	53.3	27.0	39.3	51.6	25.1	37.4	49.7	23.0	35.3	47.6		
	76	TC	—	83.3	83.3	—	78.4	78.4	—	72.8	72.8	—	66.7	66.7	—	60.1	60.1		
		SHC	—	32.2	43.9	—	30.7	42.6	—	29.0	41.0	—	27.1	39.2	—	25.1	37.2		
	3000 cfm	EA (wb)	58	TC	67.3	67.3	76.1	63.7	63.7	72.0	59.6	59.6	67.3	55.1	55.1	62.3	50.4	50.4	56.9
				SHC	58.6	67.3	76.1	55.4	63.7	72.0	51.8	59.6	67.3	47.9	55.1	62.3	43.8	50.4	56.9
62			TC	66.8	66.8	79.1	63.7	63.7	74.8	59.6	59.6	70.0	55.2	55.2	64.8	50.5	50.5	59.3	
			SHC	54.5	66.8	79.1	52.7	63.7	74.8	49.3	59.6	70.0	45.6	55.2	64.8	41.7	50.5	59.3	
67			TC	71.4	71.4	73.3	66.7	66.7	71.5	61.6	61.6	69.4	56.0	56.0	66.7	51.1	51.1	63.0	
			SHC	45.6	59.5	73.3	43.9	57.7	71.5	42.0	55.7	69.4	39.7	53.2	66.7	37.2	50.1	63.0	
72		TC	78.4	78.4	78.4	73.6	73.6	73.6	68.1	68.1	68.1	62.2	62.2	62.2	56.0	56.0	56.0		
		SHC	31.1	44.8	58.4	29.5	43.2	56.9	27.7	41.4	55.1	25.8	39.5	53.2	23.8	37.4	51.1		
76		TC	—	84.4	84.4	—	79.5	79.5	—	73.7	73.7	—	67.4	67.4	—	60.8	60.8		
		SHC	—	33.0	46.3	—	31.5	44.9	—	29.8	43.2	—	27.9	41.3	—	25.9	39.3		
3400 cfm		EA (wb)	58	TC	69.5	69.5	78.5	65.8	65.8	74.3	61.4	61.4	69.4	56.8	56.8	64.2	51.9	51.9	58.6
				SHC	60.5	69.5	78.5	57.3	65.8	74.3	53.5	61.4	69.4	49.4	56.8	64.2	45.1	51.9	58.6
	62		TC	69.6	69.6	81.6	65.8	65.8	77.2	61.5	61.5	72.1	56.8	56.8	66.7	51.9	51.9	60.9	
			SHC	57.5	69.6	81.6	54.4	65.8	77.2	50.8	61.5	72.1	47.0	56.8	66.7	42.9	51.9	60.9	
	67		TC	72.4	72.4	78.7	67.7	67.7	76.9	62.5	62.5	74.5	57.2	57.2	70.9	52.1	52.1	64.7	
			SHC	48.1	63.4	78.7	46.4	61.6	76.9	44.4	59.4	74.5	41.8	56.4	70.9	38.1	51.4	64.7	
	72	TC	79.4	79.4	79.4	74.5	74.5	74.5	69.0	69.0	69.0	62.9	62.9	62.9	56.6	56.6	56.6		
		SHC	31.8	47.0	62.3	30.2	45.5	60.7	28.5	43.7	59.0	26.6	41.8	57.0	24.6	39.7	54.9		
	76	TC	—	85.5	85.5	—	80.4	80.4	—	74.6	74.6	—	68.2	68.2	—	61.3	61.3		
		SHC	—	33.8	48.7	—	32.2	47.2	—	30.5	45.5	—	28.6	43.6	—	26.5	41.5		

LEGEND

- db — dry bulb
- EA — Entering Air Temperature (°F)
- SHC — Sensible Heat Capacity (1000 Btuh) gross
- TC — Total Capacity (1000 Btuh) gross
- wb — wet bulb

38AUZ12/40RFA12 Stage 2 Combination Ratings — 60 Hz

38AUZ12/40RFA12			AMBIENT TEMPERATURE (°F)																
			85			95			105			115			125				
			EA (db)			EA (db)			EA (db)			EA (db)			EA (db)				
			75	80	85	75	80	85	75	80	85	75	80	85	75	80	85		
3000 cfm	EA (wb)	58	TC	107.1	107.1	118.6	102.2	102.2	115.5	97.6	97.6	110.3	92.6	92.6	104.7	87.4	87.4	98.8	
			SHC	91.8	105.2	118.6	88.9	102.2	115.5	84.9	97.6	110.3	80.5	92.6	104.7	76.0	87.4	98.8	
		62	TC	112.1	112.1	112.9	106.7	106.7	110.3	100.7	100.7	107.4	94.6	94.6	104.3	88.3	88.3	100.9	
			SHC	82.9	97.9	112.9	80.4	95.4	110.3	77.6	92.5	107.4	74.6	89.5	104.3	71.5	86.2	100.9	
		67	TC	122.5	122.5	122.5	116.8	116.8	116.8	110.2	110.2	110.2	103.3	103.3	103.3	96.1	96.1	96.1	
			SHC	68.0	82.8	97.7	65.6	80.5	95.4	62.9	77.8	92.8	60.0	75.0	90.0	57.2	72.2	87.2	
	72	TC	134.5	134.5	134.5	127.7	127.7	127.7	120.7	120.7	120.7	113.0	113.0	113.0	105.1	105.1	105.1		
		SHC	53.2	67.5	81.9	50.6	65.1	79.6	47.9	62.5	77.2	45.0	59.8	74.5	42.1	56.9	71.7		
	76	TC	—	144.5	144.5	—	137.3	137.3	—	129.5	129.5	—	121.4	121.4	—	112.8	112.8		
		SHC	—	54.4	70.9	—	52.2	68.7	—	49.8	61.2	—	47.3	60.8	—	44.5	58.7		
	3500 cfm	EA (wb)	58	TC	111.9	111.9	126.5	107.4	107.4	121.3	102.4	102.4	115.7	97.0	97.0	109.7	91.4	91.4	103.3
				SHC	97.3	111.9	126.5	93.4	107.4	121.3	89.0	102.4	115.7	84.4	97.0	109.7	79.5	91.4	103.3
62			TC	115.3	115.3	123.1	109.9	109.9	120.3	103.7	103.7	117.0	98.2	98.2	110.2	92.3	92.3	104.5	
			SHC	88.9	106.0	123.1	86.3	103.3	120.3	83.2	100.1	117.0	78.5	94.4	110.2	74.2	89.4	104.5	
67			TC	125.9	125.9	125.9	119.9	119.9	119.9	112.8	112.8	112.8	105.5	105.5	105.5	98.1	98.1	98.1	
			SHC	71.8	89.0	106.2	69.4	86.6	103.8	66.6	83.8	101.1	63.7	81.0	98.3	60.8	78.1	95.3	
72		TC	137.9	137.9	137.9	130.7	130.7	130.7	123.2	123.2	123.2	115.2	115.2	115.2	107.0	107.0	107.0		
		SHC	54.6	71.3	88.1	51.9	68.8	85.7	49.1	66.1	83.1	46.2	63.3	80.4	43.3	60.5	77.6		
76		TC	—	147.8	147.8	—	140.3	140.3	—	132.2	132.2	—	123.8	123.8	—	—	—		
		SHC	—	56.6	75.9	—	54.3	69.3	—	51.7	67.5	—	49.1	65.4	—	—	—		
4000 cfm		EA (wb)	58	TC	116.5	116.5	131.7	111.7	111.7	126.2	106.4	106.4	120.2	100.6	100.6	113.7	94.6	94.6	106.9
				SHC	101.4	116.5	131.7	97.1	111.7	126.2	92.5	106.4	120.2	87.5	100.6	113.7	82.3	94.6	106.9
	62		TC	118.2	118.2	132.2	112.6	112.6	129.0	107.2	107.2	121.7	101.5	101.5	114.9	94.7	94.7	111.1	
			SHC	94.3	113.2	132.2	91.4	110.2	129.0	86.4	104.1	121.7	81.6	98.2	114.9	78.3	94.7	111.1	
	67		TC	128.6	128.6	128.6	122.0	122.0	122.0	114.9	114.9	114.9	107.4	107.4	107.4	99.6	99.6	103.2	
			SHC	75.6	95.0	114.4	73.0	92.4	111.9	70.2	89.6	109.1	67.3	86.7	106.2	64.3	83.7	103.2	
	72	TC	140.1	140.1	140.1	133.0	133.0	133.0	125.2	125.2	125.2	117.0	117.0	117.0	108.6	108.6	108.6		
		SHC	55.7	74.7	93.8	53.1	72.3	91.4	50.3	69.5	88.8	47.4	66.7	86.0	44.5	63.9	83.2		
	76	TC	—	150.5	150.5	—	142.9	142.9	—	134.6	134.6	—	—	—	—	—	—		
		SHC	—	58.5	75.9	—	56.1	74.1	—	53.5	71.9	—	—	—	—	—	—		
	4500 cfm	EA (wb)	58	TC	120.3	120.3	136	115.4	115.4	130.4	109.6	109.6	123.8	103.6	103.6	117.1	97.3	97.3	109.9
				SHC	104.7	120.3	136	100.4	115.4	130.4	95.3	109.6	123.8	90.2	103.6	117.1	84.6	97.3	109.9
62			TC	121.6	121.6	138.7	116.5	116.5	131.3	110.4	110.4	125.9	103.6	103.6	121.6	97.3	97.3	114.2	
			SHC	98.4	118.5	138.7	93.4	112.3	131.3	89.3	107.6	125.9	85.6	103.6	121.6	80.4	97.3	114.2	
67			TC	130.4	130.4	130.4	123.8	123.8	123.8	116.7	116.7	116.9	108.6	108.6	113.6	100.8	100.8	110.4	
			SHC	78.9	100.5	122.1	76.4	98.0	119.6	73.7	95.3	116.9	70.6	92.1	113.6	67.5	89.0	110.4	
72		TC	142.0	142.0	142.0	134.8	134.8	134.8	126.8	126.8	126.8	118.4	118.4	118.4	109.8	109.8	109.8		
		SHC	56.8	78.1	99.3	54.2	75.6	96.9	51.4	72.8	94.3	48.6	70.0	91.5	45.6	67.1	88.6		
76		TC	—	152.2	152.2	—	144.5	144.5	—	135.9	135.9	—	—	—	—	—	—		
		SHC	—	59.9	80.0	—	57.5	78.0	—	54.9	75.7	—	—	—	—	—	—		
5000 cfm		EA (wb)	58	TC	123.6	123.6	139.7	118.5	118.5	133.9	112.4	112.4	127.0	106.2	106.2	120.0	99.5	99.5	112.5
				SHC	107.6	123.6	139.7	103.1	118.5	133.9	97.8	112.4	127.0	92.4	106.2	120.0	86.6	99.5	112.5
	62		TC	123.7	123.7	145.2	119.9	119.9	133.8	112.6	112.6	132.2	106.3	106.3	124.7	99.6	99.6	116.9	
			SHC	102.3	123.7	145.2	95.4	114.6	133.8	93.1	112.6	132.2	87.8	106.3	124.7	82.3	99.6	116.9	
	67		TC	132.1	132.1	132.1	125.2	125.2	127.0	117.7	117.7	123.9	109.9	109.9	121.2	101.9	101.9	117.3	
			SHC	82.3	105.9	129.6	79.7	103.4	127.0	76.8	100.3	123.9	74.0	97.6	121.2	70.7	94.0	117.3	
	72	TC	143.7	143.7	143.7	136.3	136.3	136.3	128.1	128.1	128.1	119.6	119.6	119.6	110.7	110.7	110.7		
		SHC	57.8	81.3	104.7	55.3	78.8	102.2	52.5	76.0	99.6	49.6	73.2	96.8	46.7	70.3	93.9		
	76	TC	—	154.1	154.1	—	146.1	146.1	—	—	—	—	—	—	—	—	—		
		SHC	—	61.4	83.9	—	58.9	81.8	—	—	—	—	—	—	—	—	—		

LEGEND

- db — dry bulb
- EA — Entering Air Temperature (°F)
- SHC — Sensible Heat Capacity (1000 Btuh) gross
- TC — Total Capacity (1000 Btuh) gross
- wb — wet bulb

38AUZ12/40RFA12 Stage 1 Combination Ratings — 60 Hz

38AUZ12/40RFA12			AMBIENT TEMPERATURE (°F)																
			85			95			105			115			125				
			EA (db)			EA (db)			EA (db)			EA (db)			EA (db)				
			75	80	85	75	80	85	75	80	85	75	80	85	75	80	85		
2500 cfm	EA (wb)	58	TC	74.8	74.8	84.8	70.2	70.2	79.5	65.4	65.4	74.0	60.2	60.2	68.2	55.0	55.0	62.3	
			SHC	64.9	74.8	84.8	60.9	70.2	79.5	56.7	65.4	74.0	52.2	60.2	68.2	47.7	55.0	62.3	
		62	TC	76.2	76.2	85.8	71.0	71.0	81.5	64.5	64.5	76.7	60.3	60.3	71.0	55.1	55.1	64.8	
			SHC	60.7	73.3	85.8	57.3	69.4	81.5	52.3	64.5	76.7	49.6	60.3	71.0	45.3	55.1	64.8	
		67	TC	84.7	84.7	84.7	78.4	78.4	78.4	71.6	71.6	71.6	64.6	64.6	66.8	57.5	57.5	64.0	
			SHC	49.1	61.8	74.5	46.6	59.3	72.1	44.0	56.7	69.4	41.3	54.0	66.8	38.6	51.3	64.0	
	72	TC	94.1	94.1	94.1	87.6	87.6	87.6	80.5	80.5	80.5	72.9	72.9	72.9	—	—	—		
		SHC	37.1	49.6	62.0	34.8	47.3	59.8	32.2	44.8	57.4	29.6	42.2	54.8	—	—	—		
	76	TC	—	102.3	102.3	—	—	—	—	—	—	—	—	—	—	—	—		
		SHC	—	39.6	50.4	—	—	—	—	—	—	—	—	—	—	—	—		
	3000 cfm	EA (wb)	58	TC	79.8	79.8	90.4	74.9	74.9	84.8	69.6	69.6	78.8	64.0	64.0	72.5	58.3	58.3	66.0
				SHC	69.2	79.8	90.4	65.0	74.9	84.8	60.4	69.6	78.8	55.5	64.0	72.5	50.6	58.3	66.0
62			TC	80.6	80.6	92.5	73.5	73.5	87.8	69.6	69.6	81.9	64.1	64.1	75.4	58.3	58.3	68.6	
			SHC	65.1	78.8	92.5	59.2	73.5	87.8	57.3	69.6	81.9	52.7	64.1	75.4	48.0	58.3	68.6	
67			TC	87.3	87.3	87.3	80.8	80.8	80.8	73.7	73.7	78.0	66.4	66.4	75.0	59.1	59.1	71.7	
			SHC	53.1	68.2	83.2	50.6	65.7	80.7	47.9	63.0	78.0	45.1	60.1	75.0	42.2	57.0	71.7	
72		TC	96.7	96.7	96.7	90.2	90.2	90.2	82.6	82.6	82.6	—	—	—	—	—	—		
		SHC	38.7	53.5	68.3	36.4	51.3	66.1	33.8	48.7	63.7	—	—	—	—	—	—		
76		TC	—	—	—	—	—	—	—	—	—	—	—	—	—	—	—		
		SHC	—	—	—	—	—	—	—	—	—	—	—	—	—	—	—		
3500 cfm		EA (wb)	58	TC	83.8	83.8	94.9	78.6	78.6	89.0	73.0	73.0	82.6	67.1	67.1	75.9	60.9	60.9	68.9
				SHC	72.7	83.8	94.9	68.2	78.6	89.0	63.4	73.0	82.6	58.2	67.1	75.9	52.8	60.9	68.9
	62		TC	83.9	83.9	98.7	78.7	78.7	92.5	73.1	73.1	85.9	67.1	67.1	78.9	60.9	60.9	71.7	
			SHC	69.1	83.9	98.7	64.8	78.7	92.5	60.2	73.1	85.9	55.3	67.1	78.9	50.2	60.9	71.7	
	67		TC	89.3	89.3	91.5	82.6	82.6	88.8	75.4	75.4	85.8	68.0	68.0	82.3	61.7	61.7	75.2	
			SHC	56.9	74.2	91.5	54.3	71.6	88.8	51.6	68.7	85.8	48.6	65.4	82.3	44.3	59.7	75.2	
	72	TC	98.7	98.7	98.7	91.8	91.8	91.8	—	—	—	—	—	—	—	—	—		
		SHC	40.1	57.3	74.4	37.8	55.0	72.1	—	—	—	—	—	—	—	—	—		
	76	TC	—	—	—	—	—	—	—	—	—	—	—	—	—	—	—		
		SHC	—	—	—	—	—	—	—	—	—	—	—	—	—	—	—		
	4000 cfm	EA (wb)	58	TC	87.1	87.1	98.5	81.6	81.6	92.4	75.7	75.7	85.7	69.5	69.5	78.6	63.0	63.0	71.3
				SHC	75.6	87.1	98.5	70.9	81.6	92.4	65.8	75.7	85.7	60.3	69.5	78.6	54.7	63.0	71.3
62			TC	87.1	87.1	102.5	81.7	81.7	96.1	75.8	75.8	89.1	69.5	69.5	81.8	63.0	63.0	74.1	
			SHC	71.8	87.1	102.5	67.4	81.7	96.1	62.5	75.8	89.1	57.3	69.5	81.8	51.9	63.0	74.1	
67			TC	90.9	90.9	99.1	84.1	84.1	96.3	76.9	76.9	92.8	69.9	69.9	86.9	—	—	—	
			SHC	60.4	79.7	99.1	57.8	77.1	96.3	54.8	73.8	92.8	50.9	68.9	86.9	—	—	—	
72		TC	100.1	100.1	100.1	93.2	93.2	93.2	—	—	—	—	—	—	—	—	—		
		SHC	41.4	60.8	80.1	39.2	58.5	77.9	—	—	—	—	—	—	—	—	—		
76		TC	—	—	—	—	—	—	—	—	—	—	—	—	—	—	—		
		SHC	—	—	—	—	—	—	—	—	—	—	—	—	—	—	—		
4500 cfm		EA (wb)	58	TC	89.7	89.7	101.5	84.2	84.2	95.2	78.1	78.1	88.3	71.6	71.6	81.0	—	—	—
				SHC	77.9	89.7	101.5	73.1	84.2	95.2	67.8	78.1	88.3	62.2	71.6	81.0	—	—	—
	62		TC	89.8	89.8	105.6	84.2	84.2	99.0	78.1	78.1	91.8	71.6	71.6	84.2	—	—	—	
			SHC	74.0	89.8	105.6	69.4	84.2	99.0	64.4	78.1	91.8	59.0	71.6	84.2	—	—	—	
	67		TC	92.1	92.1	106.1	85.3	85.3	102.9	79.1	79.1	95.4	72.3	72.3	87.4	—	—	—	
			SHC	63.6	84.9	106.1	60.9	81.9	102.9	56.4	75.9	95.4	51.7	69.5	87.4	—	—	—	
	72	TC	101.3	101.3	101.3	—	—	—	—	—	—	—	—	—	—	—	—		
		SHC	42.7	64.2	85.7	—	—	—	—	—	—	—	—	—	—	—	—		
	76	TC	—	—	—	—	—	—	—	—	—	—	—	—	—	—	—		
		SHC	—	—	—	—	—	—	—	—	—	—	—	—	—	—	—		

LEGEND

- db — dry bulb
- EA — Entering Air Temperature (°F)
- SHC — Sensible Heat Capacity (1000 Btuh) gross
- TC — Total Capacity (1000 Btuh) gross
- wb — wet bulb

38AUD12/40RFA12 Stage 3 Combination Ratings — 60 Hz

38AUD12/40RFA12				AMBIENT TEMPERATURE (°F)															
				85			95			105			115			125			
				EA (db)			EA (db)			EA (db)			EA (db)			EA (db)			
				75	80	85	75	80	85	75	80	85	75	80	85	75	80	85	
3000 cfm	EA (wb)	58	TC	100.7	100.7	111.7	96.2	96.2	109.6	92.4	92.4	105.3	88.4	88.4	100.7	83.9	83.9	95.6	
			SHC	85.0	98.3	111.7	82.8	96.2	109.6	79.6	92.4	105.3	76.1	88.4	100.7	72.3	83.9	95.6	
		62	TC	109.8	109.8	109.8	101.9	101.9	103.8	96.9	96.9	101.4	91.5	91.5	99.0	85.8	85.8	96.2	
			SHC	75.3	89.3	103.3	74.4	89.1	103.8	72.1	86.7	101.4	69.7	84.3	99.0	67.1	81.6	96.2	
		67	TC	118.9	118.9	118.9	113.6	113.6	113.6	107.9	107.9	107.9	101.9	101.9	101.9	95.4	95.4	95.4	
			SHC	62.7	77.3	92.0	60.7	75.3	90.0	58.4	73.1	87.9	56.1	70.8	85.6	53.6	68.4	83.1	
	72	TC	132.3	132.3	132.3	126.3	126.3	126.3	120.1	120.1	120.1	113.4	113.4	113.4	106.2	106.2	106.2		
		SHC	49.1	63.2	77.2	46.8	61.1	75.3	44.6	59.0	73.3	42.2	56.7	71.2	39.7	54.3	68.8		
	76	TC	—	144.0	144.0	—	137.6	137.6	—	130.7	130.7	—	123.3	123.3	—	115.2	115.2		
		SHC	—	51.2	67.7	—	49.2	65.7	—	47.4	63.9	—	45.2	58.3	—	42.8	56.7		
	3500 cfm	EA (wb)	58	TC	106.1	106.1	120.7	102.3	102.3	116.4	98.2	98.2	111.7	93.7	93.7	106.6	88.9	88.9	101.1
				SHC	91.5	106.1	120.7	88.3	102.3	116.4	84.7	98.2	111.7	80.8	93.7	106.6	76.6	88.9	101.1
62			TC	110.6	110.6	116.6	105.7	105.7	114.3	100.4	100.4	111.8	94.9	94.9	108.6	89.6	89.6	103.8	
			SHC	83.0	99.8	116.6	80.8	97.6	114.3	78.4	95.1	111.8	75.6	92.1	108.6	72.1	87.9	103.8	
67			TC	122.8	122.8	122.8	117.1	117.1	117.1	111.2	111.2	111.2	104.8	104.8	104.8	98.0	98.0	98.0	
			SHC	67.2	84.0	100.9	65.0	81.9	98.8	62.7	79.7	96.6	60.3	77.2	94.2	57.8	74.7	91.7	
72		TC	136.2	136.2	136.2	129.7	129.7	129.7	123.4	123.4	123.4	116.4	116.4	116.4	108.8	108.8	108.8		
		SHC	51.0	67.4	83.9	48.6	65.2	81.8	46.4	63.1	79.7	44.0	60.8	77.5	41.4	58.2	75.0		
76		TC	—	148.0	148.0	—	141.1	141.1	—	133.8	133.8	—	126.1	126.1	—	117.8	117.8		
		SHC	—	53.8	73.1	—	51.9	66.5	—	49.7	65.2	—	47.4	63.4	—	44.9	61.3		
4000 cfm		EA (wb)	58	TC	111.5	111.5	126.7	107.3	107.3	122.0	102.9	102.9	116.9	98.1	98.1	111.5	92.9	92.9	105.5
				SHC	96.3	111.5	126.7	92.7	107.3	122.0	88.9	102.9	116.9	84.8	98.1	111.5	80.2	92.9	105.5
	62		TC	114.1	114.1	126.5	109.0	109.0	123.6	103.7	103.7	120.5	99.2	99.2	113.1	93.0	93.0	109.9	
			SHC	89.1	107.8	126.5	86.6	105.1	123.6	83.9	102.2	120.5	79.1	96.1	113.1	76.2	93.0	109.9	
	67		TC	126.0	126.0	126.0	119.9	119.9	119.9	113.8	113.8	113.8	107.1	107.1	107.1	100.0	100.0	100.0	
			SHC	71.3	90.3	109.4	69.0	88.1	107.1	66.7	85.8	104.8	64.3	83.3	102.4	61.6	80.7	99.7	
	72	TC	139.4	139.4	139.4	132.7	132.7	132.7	125.9	125.9	125.9	118.5	118.5	118.5	110.7	110.7	110.7		
		SHC	52.7	71.4	90.0	50.4	69.1	87.9	48.1	66.9	85.7	45.6	64.5	83.4	43.0	61.9	80.9		
	76	TC	—	151.1	151.1	—	143.7	143.7	—	136.3	136.3	—	128.3	128.3	—	119.7	119.7		
		SHC	—	56.0	73.1	—	53.9	71.6	—	51.7	69.8	—	49.3	67.7	—	46.7	65.4		
	4500 cfm	EA (wb)	58	TC	116.0	116.0	131.7	111.6	111.6	126.7	106.9	106.9	121.3	101.8	101.8	115.5	96.2	96.2	109.2
				SHC	100.4	116.0	131.7	96.5	111.6	126.7	92.4	106.9	121.3	88.0	101.8	115.5	83.2	96.2	109.2
62			TC	117.1	117.1	134.4	112.0	112.0	131.3	107.3	107.3	125.6	102.1	102.1	119.9	96.3	96.3	113.6	
			SHC	94.0	114.2	134.4	91.4	111.4	131.3	87.5	106.6	125.6	83.4	101.7	119.9	79.0	96.3	113.6	
67			TC	129.3	129.3	129.3	123.0	123.0	123.0	115.7	115.7	115.7	108.9	108.9	110.2	102.2	102.2	109.3	
			SHC	76.1	97.7	119.3	73.8	95.4	117.0	70.4	91.5	112.7	68.0	89.1	110.2	66.2	87.8	109.3	
72		TC	141.7	141.7	141.7	135.0	135.0	135.0	127.9	127.9	127.9	120.4	120.4	120.4	112.3	112.3	112.3		
		SHC	54.1	75.0	95.8	51.9	72.8	93.7	49.5	70.5	91.4	47.0	68.0	89.1	44.4	65.4	86.5		
76		TC	—	153.3	153.3	—	146.1	146.1	—	138.3	138.3	—	130.1	130.1	—	121.2	121.2		
		SHC	—	57.9	77.6	—	55.7	75.8	—	53.4	73.8	—	51.0	71.6	—	48.4	69.2		
5000 cfm		EA (wb)	58	TC	120.0	120.0	136.1	115.2	115.2	130.7	110.3	110.3	125.1	104.9	104.9	119.0	99.1	99.1	112.4
				SHC	103.9	120.0	136.1	99.8	115.2	130.7	95.5	110.3	125.1	90.9	104.9	119.0	85.8	99.1	112.4
	62		TC	120.9	120.9	138.7	115.5	115.5	136.1	111.0	111.0	128.8	105.0	105.0	123.8	99.2	99.2	116.9	
			SHC	97.3	118.0	138.7	94.8	115.5	136.1	90.1	109.4	128.8	86.2	105.0	123.8	81.5	99.2	116.9	
	67		TC	130.3	130.3	130.3	124.0	124.0	124.0	117.4	117.4	120.2	110.4	110.4	117.4	103.0	103.0	114.5	
			SHC	78.8	101.9	125.1	76.5	99.6	122.7	74.0	97.1	120.2	71.4	94.4	117.4	68.7	91.6	114.5	
	72	TC	143.7	143.7	143.7	136.7	136.7	136.7	129.4	129.4	129.4	121.9	121.9	121.9	113.6	113.6	113.6		
		SHC	55.5	78.4	101.3	53.2	76.2	99.1	50.8	73.8	96.8	48.4	71.4	94.5	45.7	68.8	91.8		
	76	TC	—	155.5	155.5	—	147.7	147.7	—	139.6	139.6	—	131.4	131.4	—	122.5	122.5		
		SHC	—	59.6	81.6	—	57.2	79.6	—	54.9	77.5	—	52.5	75.2	—	49.9	72.7		

LEGEND

- db — dry bulb
- EA — Entering Air Temperature (°F)
- SHC — Sensible Heat Capacity (1000 Btuh) gross
- TC — Total Capacity (1000 Btuh) gross
- wb — wet bulb

38AUD12/40RFA12 Stage 2 Combination Ratings — 60 Hz

38AUD12/40RFA12				AMBIENT TEMPERATURE (°F)															
				85			95			105			115			125			
				EA (db)			EA (db)			EA (db)			EA (db)			EA (db)			
				75	80	85	75	80	85	75	80	85	75	80	85	75	80	85	
2500 cfm	EA (wb)	58	TC	88.4	88.4	97.2	84.8	84.8	94.5	81.1	81.1	90.3	76.4	76.4	86.4	71.7	71.7	81.1	
			SHC	75.2	86.2	97.2	72.9	83.7	94.5	69.7	80.0	90.3	66.4	76.4	86.4	62.4	71.7	81.1	
		62	TC	93.1	93.1	93.1	88.6	88.6	90.3	83.9	83.9	87.0	79.1	79.1	83.2	73.5	73.5	79.7	
			SHC	68.3	80.4	92.6	66.1	78.2	90.3	63.3	75.1	87.0	60.2	71.7	83.2	57.2	68.4	79.7	
		67	TC	102.6	102.6	102.6	97.7	97.7	97.7	92.4	92.4	92.4	86.6	86.6	86.6	80.1	80.1	80.1	
			SHC	56.4	68.5	80.5	54.4	66.5	78.6	52.2	64.4	76.5	49.9	62.0	74.2	47.3	59.5	71.7	
	72	TC	113.1	113.1	113.1	107.9	107.9	107.9	101.9	101.9	101.9	95.5	95.5	95.5	88.5	88.5	88.5		
		SHC	44.7	56.0	67.3	42.6	54.2	65.7	40.3	52.0	63.8	37.9	49.8	61.7	35.3	47.3	59.4		
	76	TC	—	122.2	122.2	—	116.4	116.4	—	110.3	110.3	—	—	—	—	—	—		
		SHC	—	46.2	57.8	—	44.2	56.5	—	41.8	54.3	—	—	—	—	—	—		
	3000 cfm	EA (wb)	58	TC	93.6	93.6	105.3	89.8	89.8	101.3	85.7	85.7	96.8	81.2	81.2	91.7	76.1	76.1	86.0
				SHC	81.2	93.3	105.3	78.0	89.7	101.3	74.6	85.7	96.8	70.6	81.2	91.7	66.3	76.1	86.0
62			TC	96.9	96.9	101.0	95.4	95.4	95.4	87.7	87.7	95.0	82.5	82.5	91.1	76.8	76.8	86.7	
			SHC	73.4	87.2	101.0	69.0	82.0	94.9	68.3	81.6	95.0	65.1	78.1	91.1	61.6	74.2	86.7	
67			TC	106.2	106.2	106.2	101.0	101.0	101.0	95.4	95.4	95.4	89.2	89.2	89.2	82.5	82.5	82.5	
			SHC	60.5	74.7	89.0	58.4	72.7	87.0	56.2	70.5	84.8	53.7	68.1	82.5	51.1	65.4	79.8	
72		TC	116.7	116.7	116.7	111.0	111.0	111.0	104.9	104.9	104.9	98.1	98.1	98.1	90.8	90.8	90.8		
		SHC	46.2	60.0	73.8	44.1	58.0	72.0	41.8	55.9	70.0	39.4	53.6	67.7	36.8	51.1	65.3		
76		TC	—	126.1	126.1	—	—	—	—	—	—	—	—	—	—	—	—		
		SHC	—	47.9	62.7	—	—	—	—	—	—	—	—	—	—	—	—		
3500 cfm		EA (wb)	58	TC	98.2	98.2	110.9	94.5	94.5	106.8	89.9	89.9	101.5	84.9	84.9	95.9	79.5	79.5	89.8
				SHC	85.5	98.2	110.9	82.3	94.5	106.8	78.2	89.9	101.5	73.9	84.9	95.9	69.2	79.5	89.8
	62		TC	100.2	100.2	109.2	95.8	95.8	105.7	90.9	90.9	102.0	85.4	85.4	97.8	80.0	80.0	92.2	
			SHC	78.4	93.8	109.2	75.6	90.7	105.7	72.6	87.3	102.0	69.3	83.6	97.8	65.3	78.8	92.2	
	67		TC	108.9	108.9	108.9	103.7	103.7	103.7	97.6	97.6	97.6	91.0	91.0	91.0	84.0	84.0	87.0	
			SHC	64.2	80.6	97.1	62.5	79.1	95.7	59.8	76.2	92.6	57.3	73.6	90.0	54.4	70.7	87.0	
	72	TC	119.4	119.4	119.4	113.5	113.5	113.5	107.3	107.3	107.3	100.3	100.3	100.3	—	—	—		
		SHC	47.6	63.7	79.7	45.5	61.6	77.8	43.3	59.5	75.7	40.9	57.2	73.5	—	—	—		
	76	TC	—	—	—	—	—	—	—	—	—	—	—	—	—	—	—		
		SHC	—	—	—	—	—	—	—	—	—	—	—	—	—	—	—		
	4000 cfm	EA (wb)	58	TC	102.1	102.1	115.3	97.8	97.8	110.5	93.2	93.2	105.2	88	88	99.4	82.3	82.3	92.9
				SHC	88.9	102.1	115.3	85.2	97.8	110.5	81.1	93.2	105.2	76.6	88.0	99.4	71.6	82.3	92.9
62			TC	103.3	103.3	115.7	98.5	98.5	112.2	93.6	93.6	108.3	88.6	88.6	101.9	82.7	82.7	95.1	
			SHC	82.5	99.1	115.7	79.7	96.0	112.2	76.7	92.5	108.3	72.3	87.1	101.9	67.5	81.3	95.1	
67			TC	111.0	111.0	111.0	105.3	105.3	105.3	99.3	99.3	99.9	92.7	92.7	97.0	85.6	85.6	92.6	
			SHC	67.7	86.1	104.5	65.5	83.9	102.3	63.2	81.5	99.9	60.5	78.8	97.0	57.1	74.9	92.6	
72		TC	121.5	121.5	121.5	115.5	115.5	115.5	108.7	108.7	108.7	101.6	101.6	101.6	—	—	—		
		SHC	48.9	67.1	85.2	46.8	65.1	83.3	44.5	62.8	81.1	42.1	60.4	78.8	—	—	—		
76		TC	—	—	—	—	—	—	—	—	—	—	—	—	—	—	—		
		SHC	—	—	—	—	—	—	—	—	—	—	—	—	—	—	—		
4500 cfm		EA (wb)	58	TC	105.3	105.3	118.9	100.9	100.9	114.0	96.0	96.0	108.4	90.6	90.6	102.3	84.6	84.6	95.5
				SHC	91.7	105.3	118.9	87.9	100.9	114.0	83.6	96.0	108.4	78.9	90.6	102.3	73.7	84.6	95.5
	62		TC	105.8	105.8	121.7	101.3	101.3	116.9	96.0	96.0	112.6	90.9	90.9	106.3	84.8	84.8	99.3	
			SHC	86.3	104.0	121.7	82.9	99.9	116.9	79.5	96.0	112.6	75.2	90.7	106.3	70.2	84.8	99.3	
	67		TC	112.5	112.5	112.5	106.8	106.8	109.2	100.6	100.6	106.4	94.7	94.7	102.0	87.3	87.3	96.8	
			SHC	70.9	91.2	111.5	68.7	89.0	109.2	66.2	86.3	106.4	63.0	82.5	102.0	59.1	77.9	96.8	
	72	TC	123.1	123.1	123.1	117.1	117.1	117.1	110.2	110.2	110.2	—	—	—	—	—	—		
		SHC	50.1	70.3	90.5	48.0	68.3	88.5	45.7	66.0	86.3	—	—	—	—	—	—		
	76	TC	—	—	—	—	—	—	—	—	—	—	—	—	—	—	—		
		SHC	—	—	—	—	—	—	—	—	—	—	—	—	—	—	—		

LEGEND

- db — dry bulb
- EA — Entering Air Temperature (°F)
- SHC — Sensible Heat Capacity (1000 Btuh) gross
- TC — Total Capacity (1000 Btuh) gross
- wb — wet bulb

38AUD12/40RFA12 Stage 1 Combination Ratings — 60 Hz

38AUD12/40RFA12			AMBIENT TEMPERATURE (°F)																
			85			95			105			115			125				
			EA (db)			EA (db)			EA (db)			EA (db)			EA (db)				
			75	80	85	75	80	85	75	80	85	75	80	85	75	80	85		
2500 cfm	EA (wb)	58	TC	34.0	34.0	38.9	32.6	32.6	37.2	30.9	30.9	35.2	29.0	29.0	33.2	26.9	26.9	30.8	
			SHC	29.2	34.0	38.9	27.9	32.6	37.2	26.5	30.9	35.2	24.9	29.0	33.2	23.1	26.9	30.8	
		62	TC	34.5	34.5	38.6	33.8	33.8	36.3	31.6	31.6	34.2	29.0	29.0	34.6	26.9	26.9	32.0	
			SHC	26.7	32.7	38.6	25.4	30.8	36.3	23.9	29.0	34.2	23.4	29.0	34.6	21.8	26.9	32.0	
		67	TC	38.4	38.4	38.4	36.3	36.3	36.3	33.9	33.9	33.9	31.4	31.4	32.2	28.5	28.5	31.2	
			SHC	21.7	28.1	34.5	21.0	27.4	33.8	19.9	26.0	32.2	19.3	25.7	32.2	18.3	24.7	31.2	
	72	TC	43.1	43.1	43.1	40.9	40.9	40.9	38.4	38.4	38.4	35.6	35.6	35.6	32.6	32.6	32.6		
		SHC	15.9	22.1	28.3	15.2	21.5	27.7	14.4	20.7	27.1	13.5	19.9	26.4	12.6	19.0	25.5		
	76	TC	—	47.3	47.3	—	45.0	45.0	—	42.4	42.4	—	—	—	—	—	—		
		SHC	—	17.1	21.9	—	16.5	22.0	—	15.9	21.8	—	—	—	—	—	—		
	3000 cfm	EA (wb)	58	TC	36.1	36.1	41.2	34.5	34.5	39.3	32.8	32.8	37.3	30.7	30.7	35.0	28.5	28.5	32.4
				SHC	31.1	36.1	41.2	29.7	34.5	39.3	28.2	32.8	37.3	26.4	30.7	35.0	24.5	28.5	32.4
62			TC	36.4	36.4	41.8	34.7	34.7	40.8	32.8	32.8	38.8	30.7	30.7	36.5	28.5	28.5	33.8	
			SHC	28.9	35.4	41.8	28.1	34.4	40.8	26.7	32.8	38.8	25.0	30.7	36.5	23.2	28.5	33.8	
67			TC	39.5	39.5	39.5	37.3	37.3	37.6	35.1	35.1	37.0	32.3	32.3	35.9	29.3	29.3	34.5	
			SHC	23.6	30.9	38.2	22.9	30.2	37.6	22.2	29.6	37.0	21.1	28.5	35.9	20.0	27.2	34.5	
72		TC	44.2	44.2	44.2	41.9	41.9	41.9	39.3	39.3	39.3	36.5	36.5	36.5	33.3	33.3	33.3		
		SHC	16.7	24.0	31.2	16.0	23.3	30.6	15.2	22.5	29.9	14.3	21.7	29.2	13.3	20.8	28.3		
76		TC	—	48.4	48.4	—	46.0	46.0	—	—	—	—	—	—	—	—	—		
		SHC	—	18.2	24.8	—	17.6	24.5	—	—	—	—	—	—	—	—	—		
3500 cfm		EA (wb)	58	TC	37.7	37.7	42.9	36.1	36.1	41.0	34.0	34.0	38.7	32.1	32.1	36.5	29.7	29.7	33.8
				SHC	32.5	37.7	42.9	31.1	36.1	41.0	29.4	34.0	38.7	27.7	32.1	36.5	25.6	29.7	33.8
	62		TC	38.4	38.4	41.5	36.1	36.1	42.7	34.2	34.2	40.4	32.1	32.1	38.0	29.7	29.7	35.2	
			SHC	29.3	35.4	41.5	29.5	36.1	42.7	27.9	34.2	40.4	26.2	32.1	38.0	24.3	29.7	35.2	
	67		TC	40.4	40.4	41.8	38.1	38.1	41.0	35.7	35.7	40.3	32.9	32.9	38.9	30.0	30.0	37.0	
			SHC	25.3	33.5	41.8	24.6	32.8	41.0	23.8	32.0	40.3	22.7	30.8	38.9	21.3	29.1	37.0	
	72	TC	45.0	45.0	45.0	42.7	42.7	42.7	40.1	40.1	40.1	37.2	37.2	37.2	33.9	33.9	33.9		
		SHC	17.4	25.5	33.7	16.7	24.9	33.2	15.9	24.2	32.6	15.0	23.3	31.7	14.0	22.4	30.8		
	76	TC	—	49.2	49.2	—	—	—	—	—	—	—	—	—	—	—	—		
		SHC	—	19.1	26.9	—	—	—	—	—	—	—	—	—	—	—	—		
	4000 cfm	EA (wb)	58	TC	39.1	39.1	44.5	37.4	37.4	42.5	35.4	35.4	40.2	33.2	33.2	37.7	30.7	30.7	34.9
				SHC	33.8	39.1	44.5	32.3	37.4	42.5	30.6	35.4	40.2	28.7	33.2	37.7	26.5	30.7	34.9
62			TC	39.1	39.1	46.2	37.4	37.4	44.2	35.4	35.4	41.8	33.2	33.2	39.2	30.7	30.7	36.3	
			SHC	32.0	39.1	46.2	30.6	37.4	44.2	29.0	35.4	41.8	27.2	33.2	39.2	25.2	30.7	36.3	
67			TC	41.0	41.0	45.1	38.8	38.8	44.2	36.3	36.3	43.0	33.6	33.6	41.3	30.8	30.8	38.2	
			SHC	26.9	36.0	45.1	26.1	35.2	44.2	25.1	34.0	43.0	23.9	32.6	41.3	22.1	30.2	38.2	
72		TC	45.7	45.7	45.7	43.3	43.3	43.3	40.6	40.6	40.6	37.7	37.7	37.7	34.4	34.4	34.4		
		SHC	18.0	27.1	36.3	17.3	26.5	35.7	16.4	25.7	34.9	15.6	24.9	34.2	14.6	23.9	33.1		
76		TC	—	49.9	49.9	—	—	—	—	—	—	—	—	—	—	—	—		
		SHC	—	19.8	28.9	—	—	—	—	—	—	—	—	—	—	—	—		
4500 cfm		EA (wb)	58	TC	40.3	40.3	45.7	38.5	38.5	43.7	36.4	36.4	41.3	34.1	34.1	38.7	31.6	31.6	35.8
				SHC	34.8	40.3	45.7	33.3	38.5	43.7	31.5	36.4	41.3	29.5	34.1	38.7	27.3	31.6	35.8
	62		TC	40.3	40.3	47.5	38.4	38.4	45.4	36.4	36.4	43.0	34.2	34.2	40.3	31.6	31.6	37.3	
			SHC	33.0	40.3	47.5	31.5	38.4	45.4	29.9	36.4	43.0	28.0	34.2	40.3	25.9	31.6	37.3	
	67		TC	41.6	41.6	48.0	39.3	39.3	46.9	36.9	36.9	45.3	34.2	34.2	43.3	32.3	32.3	36.7	
			SHC	28.4	38.2	48.0	27.5	37.2	46.9	26.4	35.9	45.3	25.0	34.2	43.3	21.8	29.2	36.7	
	72	TC	46.2	46.2	46.2	43.8	43.8	43.8	41.1	41.1	41.1	38.1	38.1	38.1	—	—	—		
		SHC	18.5	28.5	38.6	17.8	27.9	38.0	16.9	27	37.1	16.2	26.3	36.5	—	—	—		
	76	TC	—	—	—	—	—	—	—	—	—	—	—	—	—	—	—		
		SHC	—	—	—	—	—	—	—	—	—	—	—	—	—	—	—		

LEGEND

- db — dry bulb
- EA — Entering Air Temperature (°F)
- SHC — Sensible Heat Capacity (1000 Btuh) gross
- TC — Total Capacity (1000 Btuh) gross
- wb — wet bulb

38AUZ14/40RUA14 Stage 2 Combination Ratings — 60 Hz

38AUZ14/40RUA14			AMBIENT TEMPERATURE (°F)																
			85			95			105			115			125				
			EA (db)			EA (db)			EA (db)			EA (db)			EA (db)				
			75	80	85	75	80	85	75	80	85	75	80	85	75	80	85		
3750 cfm	EA (wb)	58	TC	120.0	120.0	136.9	115.6	115.6	131.9	110.8	110.8	126.5	105.6	105.6	120.5	99.9	99.9	114.0	
		58	SHC	103.0	120.0	136.9	99.3	115.6	131.9	95.2	110.8	126.5	90.7	105.6	120.5	85.8	99.9	114.0	
		62	TC	126.4	126.4	132.3	120.3	120.3	129.6	114.0	114.0	126.6	107.1	107.1	123.4	100.8	100.8	117.8	
		62	SHC	93.5	112.9	132.3	90.8	110.2	129.6	88.0	107.3	126.6	84.9	104.1	123.4	80.8	99.3	117.8	
		67	TC	141.7	141.7	141.7	135.2	135.2	135.2	128.1	128.1	128.1	120.5	120.5	120.5	112.2	112.2	112.2	
		67	SHC	75.7	95.1	114.4	73.2	92.6	111.9	70.5	89.9	109.3	67.7	87.1	106.6	64.6	84.1	103.5	
	72	TC	158.4	158.4	158.4	151.2	151.2	151.2	143.4	143.4	143.4	135.1	135.1	135.1	126.1	126.1	126.1		
	72	SHC	58.0	77.0	95.9	55.5	74.5	93.5	52.7	71.8	91.0	49.8	69.0	88.2	46.8	66.0	85.3		
	76	TC	—	172.9	172.9	—	164.9	164.9	—	156.4	156.4	—	147.3	147.3	—	137.6	137.6		
	76	SHC	—	62.1	82.8	—	59.7	76.8	—	57.1	75.1	—	54.4	72.8	—	51.4	70.2		
	4400 cfm	EA (wb)	58	TC	128.4	128.4	146.3	123.6	123.6	140.8	118.3	118.3	134.8	112.7	112.7	128.3	106.4	106.4	121.2
			58	SHC	110.6	128.4	146.3	106.4	123.6	140.8	101.9	118.3	134.8	97.0	112.7	128.3	91.7	106.4	121.2
62			TC	131.4	131.4	147.3	125.1	125.1	144.1	119.2	119.2	139.3	113.8	113.8	131.5	106.6	106.6	126.3	
62			SHC	102.7	125.0	147.3	99.8	122.0	144.1	96.1	117.7	139.3	91.0	111.3	131.5	86.8	106.6	126.3	
67			TC	146.6	146.6	146.6	139.8	139.8	139.8	132.3	132.3	132.3	124.1	124.1	124.1	115.6	115.6	115.6	
67			SHC	81.9	104.4	126.9	79.4	101.9	124.4	76.6	99.1	121.7	73.6	96.2	118.7	70.5	93.0	115.6	
72		TC	163.4	163.4	163.4	155.7	155.7	155.7	147.6	147.6	147.6	138.8	138.8	138.8	129.3	129.3	129.3		
72		SHC	60.7	82.8	105.0	58.0	80.3	102.5	55.2	77.5	99.8	52.3	74.6	97.0	49.2	71.5	93.9		
76		TC	—	177.5	177.5	—	169.1	169.1	—	160.4	160.4	—	151.1	151.1	—	140.7	140.7		
76		SHC	—	65.3	86.0	—	62.8	84.1	—	60.1	81.7	—	57.3	79.1	—	54.2	76.2		
5000 cfm		EA (wb)	58	TC	134.9	134.9	153.4	129.7	129.7	147.5	124.2	124.2	141.2	118.0	118.0	134.3	111.4	111.4	126.7
			58	SHC	116.4	134.9	153.4	111.9	129.7	147.5	107.1	124.2	141.2	101.8	118.0	134.3	96.1	111.4	126.7
	62		TC	136.5	136.5	156.6	131.0	131.0	151.8	125.8	125.8	143.2	118.2	118.2	139.8	111.6	111.6	132.0	
	62		SHC	108.9	132.8	156.6	105.3	128.6	151.8	99.8	121.5	143.2	96.5	118.2	139.8	91.1	111.6	132.0	
	67		TC	150.2	150.2	150.2	143.0	143.0	143.0	135.2	135.2	135.2	126.9	126.9	129.6	117.9	117.9	126.4	
	67		SHC	87.3	112.6	137.9	84.7	110.0	135.3	81.9	107.2	132.6	78.9	104.2	129.6	75.7	101.1	126.4	
	72	TC	166.9	166.9	166.9	159.0	159.0	159.0	150.5	150.5	150.5	141.4	141.4	141.4	131.6	131.6	131.6		
	72	SHC	62.8	87.8	112.9	60.1	85.2	110.3	57.3	82.5	107.6	54.3	79.5	104.7	51.1	76.3	101.5		
	76	TC	—	180.8	180.8	—	172.4	172.4	—	163.3	163.3	—	153.5	153.5	—	142.9	142.9		
	76	SHC	—	67.7	91.8	—	65.2	89.5	—	62.4	87.0	—	59.5	84.2	—	56.3	81.2		
	5650 cfm	EA (wb)	58	TC	140.8	140.8	159.9	135.3	135.3	153.7	129.4	129.4	147.0	123.0	123.0	139.7	115.9	115.9	131.6
			58	SHC	121.7	140.8	159.9	116.9	135.3	153.7	111.8	129.4	147.0	106.2	123.0	139.7	100.1	115.9	131.6
62			TC	143.0	143.0	162.2	136.9	136.9	156.6	129.5	129.5	153.0	123.1	123.1	145.4	116.0	116.0	137.0	
62			SHC	113.5	137.9	162.2	109.4	133.0	156.6	106.1	129.5	153.0	100.8	123.1	145.4	95.0	116.0	137.0	
67			TC	153.2	153.2	153.2	145.8	145.8	146.8	137.8	137.8	144.0	129.3	129.3	140.9	119.9	119.9	137.2	
67			SHC	92.8	121.1	149.5	90.2	118.5	146.8	87.4	115.7	144.0	84.4	112.7	140.9	81.0	109.1	137.2	
72		TC	169.7	169.7	169.7	161.7	161.7	161.7	153.0	153.0	153.0	143.7	143.7	143.7	133.7	133.7	133.7		
72		SHC	64.7	92.9	121.0	62.1	90.2	118.4	59.3	87.4	115.6	56.3	84.4	112.6	53.1	81.3	109.4		
76		TC	—	183.8	183.8	—	175.1	175.1	—	165.6	165.6	—	155.6	155.6	—	144.7	144.7		
76		SHC	—	70.0	97.3	—	67.4	94.9	—	64.6	92.2	—	61.6	89.4	—	58.4	86.2		
6250 cfm		EA (wb)	58	TC	145.6	145.6	165.2	139.8	139.8	158.6	133.6	133.6	151.6	126.8	126.8	143.9	119.3	119.3	135.4
			58	SHC	125.9	145.6	165.2	120.9	139.8	158.6	115.6	133.6	151.6	109.7	126.8	143.9	103.2	119.3	135.4
	62		TC	148.5	148.5	165.8	139.9	139.9	165.1	133.7	133.7	157.8	126.9	126.9	149.7	119.5	119.5	141.0	
	62		SHC	116.8	141.3	165.8	114.8	139.9	165.1	109.7	133.7	157.8	104.1	126.9	149.7	98.0	119.5	141.0	
	67		TC	155.6	155.6	159.8	147.9	147.9	157.3	139.6	139.6	154.2	130.9	130.9	150.7	121.6	121.6	146.7	
	67		SHC	97.8	128.8	159.8	95.2	126.2	157.3	92.3	123.2	154.2	89.1	119.9	150.7	85.7	116.2	146.7	
	72	TC	172.1	172.1	172.1	163.8	163.8	163.8	154.9	154.9	154.9	145.4	145.4	145.4	135.2	135.2	135.2		
	72	SHC	66.4	97.3	128.2	63.8	94.7	125.5	60.9	91.8	122.7	58.0	88.8	119.7	54.8	85.7	116.5		
	76	TC	—	186.1	186.1	—	177.2	177.2	—	167.4	167.4	—	156.9	156.9	—	146.1	146.1		
	76	SHC	—	71.9	102.0	—	69.2	99.5	—	66.3	96.7	—	63.2	93.7	—	60.0	90.5		

LEGEND

- db — dry bulb
- EA — Entering Air Temperature (°F)
- SHC — Sensible Heat Capacity (1000 Btuh) gross
- TC — Total Capacity (1000 Btuh) gross
- wb — wet bulb

38AUZ14/40RUA14 Stage 1 Combination Ratings — 60 Hz

38AUZ14/40RUA14			AMBIENT TEMPERATURE (°F)																
			85			95			105			115			125				
			EA (db)			EA (db)			EA (db)			EA (db)			EA (db)				
			75	80	85	75	80	85	75	80	85	75	80	85	75	80	85		
3750 cfm	EA (wb)	58	TC	77.6	77.6	87.9	73.7	73.7	83.7	69.1	69.1	78.5	64.3	64.3	73.3	59.3	59.3	67.8	
		58	SHC	67.4	77.6	87.9	63.8	73.7	83.7	59.6	69.1	78.5	55.4	64.3	73.3	50.8	59.3	67.8	
		62	TC	77.7	77.7	91.4	73.5	73.5	86.7	69.1	69.1	81.8	64.4	64.4	76.4	59.2	59.2	70.5	
		62	SHC	64.0	77.7	91.4	60.3	73.5	86.7	56.5	69.1	81.8	52.4	64.4	76.4	47.9	59.2	70.5	
		67	TC	83.0	83.0	83.6	78.1	78.1	81.0	72.6	72.6	78.2	66.8	66.8	75.3	60.7	60.7	72.0	
		67	SHC	52.2	67.9	83.6	49.6	65.3	81.0	46.8	62.5	78.2	43.9	59.6	75.3	40.8	56.4	72.0	
	72	TC	91.5	91.5	91.5	86.0	86.0	86.0	80.3	80.3	80.3	74.2	74.2	74.2	67.5	67.5	67.5		
	72	SHC	36.6	52.2	67.8	34.0	49.6	65.2	31.2	46.9	62.5	28.4	44.0	59.6	25.4	41.0	56.6		
	76	TC	—	98.8	98.8	—	93.1	93.1	—	86.8	86.8	—	80.5	80.5	—	73.4	73.4		
	76	SHC	—	39.4	54.6	—	36.8	52.0	—	34.1	49.4	—	31.3	46.7	—	28.3	43.7		
	4400 cfm	EA (wb)	58	TC	81.5	81.5	92.2	77.1	77.1	87.4	72.6	72.6	82.4	67.4	67.4	76.8	62.0	62.0	70.8
			58	SHC	70.8	81.5	92.2	66.8	77.1	87.4	62.7	72.6	82.4	58.1	67.4	76.8	53.2	62.0	70.8
62			TC	81.6	81.6	95.9	77.2	77.2	90.9	72.5	72.5	85.7	67.6	67.6	80.1	62.0	62.0	73.7	
62			SHC	67.2	81.6	95.9	63.4	77.2	90.9	59.4	72.5	85.7	55.1	67.6	80.1	50.3	62.0	73.7	
67			TC	84.8	84.8	93.4	79.5	79.5	90.5	74.3	74.3	87.5	68.2	68.2	84.1	62.1	62.1	79.6	
67			SHC	56.7	75.1	93.4	54.0	72.2	90.5	51.2	69.4	87.5	48.1	66.1	84.1	44.5	62.0	79.6	
72		TC	93.4	93.4	93.4	87.9	87.9	87.9	81.8	81.8	81.8	75.5	75.5	75.5	68.6	68.6	68.6		
72		SHC	38.3	56.6	74.9	35.7	54.0	72.3	32.9	51.2	69.4	30.0	48.3	66.6	27.0	45.2	63.5		
76		TC	—	100.5	100.5	—	94.5	94.5	—	88.3	88.3	—	81.4	81.4	—	74.2	74.2		
76		SHC	—	41.4	59.3	—	38.8	56.7	—	36.0	54.0	—	33.1	51.1	—	30.1	48.0		
5000 cfm		EA (wb)	58	TC	84.9	84.9	96.0	80.3	80.3	91.0	75.4	75.4	85.6	70.1	70.1	79.7	64.3	64.3	73.3
			58	SHC	73.8	84.9	96.0	69.7	80.3	91.0	65.2	75.4	85.6	60.4	70.1	79.7	55.2	64.3	73.3
	62		TC	84.9	84.9	99.7	80.3	80.3	94.5	75.4	75.4	89.0	70.1	70.1	83.0	64.4	64.4	76.5	
	62		SHC	70.1	84.9	99.7	66.1	80.3	94.5	61.8	75.4	89.0	57.2	70.1	83.0	52.3	64.4	76.5	
	67		TC	86.3	86.3	102.9	81.1	81.1	99.3	75.9	75.9	93.7	71.2	71.2	86.9	64.6	64.6	81.7	
	67		SHC	61.2	82.0	102.9	58.2	78.7	99.3	54.3	74.0	93.7	50.0	68.5	86.9	46.0	63.9	81.7	
	72	TC	94.8	94.8	94.8	89.2	89.2	89.2	83.0	83.0	83.0	76.5	76.5	76.5	69.7	69.7	70.6		
	72	SHC	40.0	61.1	82.2	37.3	58.4	79.5	34.5	55.6	76.7	31.7	52.7	73.6	28.7	49.7	70.6		
	76	TC	—	102.1	102.1	—	95.7	95.7	—	89.4	89.4	—	82.4	82.4	—	75.2	75.2		
	76	SHC	—	43.4	64.1	—	40.6	61.3	—	37.9	58.6	—	34.9	55.5	—	31.8	52.4		
	5650 cfm	EA (wb)	58	TC	87.3	87.3	98.7	82.5	82.5	93.4	77.5	77.5	87.9	71.9	71.9	81.8	66.2	66.2	75.4
			58	SHC	75.9	87.3	98.7	71.6	82.5	93.4	67.1	77.5	87.9	62.1	71.9	81.8	56.9	66.2	75.4
62			TC	87.5	87.5	102.7	82.6	82.6	97.2	77.6	77.6	91.5	72.2	72.2	85.4	66.1	66.1	78.4	
62			SHC	72.2	87.5	102.7	68.0	82.6	97.2	63.6	77.6	91.5	59.0	72.2	85.4	53.7	66.1	78.4	
67			TC	88.2	88.2	108.4	82.9	82.9	103.6	77.6	77.6	98.5	72.3	72.3	90.7	66.1	66.1	84.6	
67			SHC	64.1	86.2	108.4	60.5	82.0	103.6	56.8	77.6	98.5	51.9	71.3	90.7	47.7	66.1	84.6	
72		TC	95.7	95.7	95.7	90.0	90.0	90.0	83.9	83.9	83.9	77.1	77.1	80.1	70.1	70.1	77.0		
72		SHC	41.4	65.0	88.6	38.8	62.3	85.9	36.0	59.6	83.2	33.1	56.6	80.1	30.1	53.6	77.0		
76		TC	—	102.8	102.8	—	96.5	96.5	—	90.0	90.0	—	83.0	83.0	—	75.5	75.5		
76		SHC	—	44.8	68.0	—	42.1	65.3	—	39.3	62.4	—	36.3	59.2	—	33.1	56.0		
6250 cfm		EA (wb)	58	TC	89.5	89.5	101.1	84.6	84.6	95.8	79.2	79.2	89.8	73.6	73.6	83.6	67.7	67.7	77.1
			58	SHC	77.9	89.5	101.1	73.5	84.6	95.8	68.6	79.2	89.8	63.6	73.6	83.6	58.2	67.7	77.1
	62		TC	89.6	89.6	105.1	84.7	84.7	99.6	79.4	79.4	93.6	73.9	73.9	87.4	67.5	67.5	80.1	
	62		SHC	74.1	89.6	105.1	69.8	84.7	99.6	65.2	79.4	93.6	60.5	73.9	87.4	55.0	67.5	80.1	
	67		TC	91.3	91.3	110.1	84.9	84.9	106.0	79.5	79.5	100.4	73.7	73.7	93.8	67.6	67.6	86.4	
	67		SHC	65.5	87.8	110.1	62.0	84.0	106.0	58.1	79.2	100.4	53.7	73.7	93.8	48.8	67.6	86.4	
	72	TC	96.6	96.6	96.6	90.6	90.6	92.6	84.4	84.4	89.8	77.7	77.7	86.7	70.6	70.6	83.4		
	72	SHC	42.9	69.1	95.3	40.2	66.4	92.6	37.5	63.6	89.8	34.7	60.7	86.7	31.7	57.6	83.4		
	76	TC	—	103.6	103.6	—	97.5	97.5	—	90.9	90.9	—	83.7	83.7	—	76.0	76.0		
	76	SHC	—	46.3	72.1	—	43.6	69.3	—	40.7	66.3	—	37.6	63.0	—	34.4	59.7		

LEGEND

- db — dry bulb
- EA — Entering Air Temperature (°F)
- SHC — Sensible Heat Capacity (1000 Btuh) gross
- TC — Total Capacity (1000 Btuh) gross
- wb — wet bulb

38AUD14/40RUA14 Stage 3 Combination Ratings — 60 Hz

38AUD14/40RUA14			AMBIENT TEMPERATURE (°F)																
			85			95			105			115			125				
			EA (db)			EA (db)			EA (db)			EA (db)			EA (db)				
			75	80	85	75	80	85	75	80	85	75	80	85	75	80	85		
3750 cfm	EA (wb)	58	TC	120.2	120.2	137.3	116.0	116.0	132.5	111.1	111.1	127.0	105.9	105.9	121.0	100.5	100.5	114.8	
		58	SHC	103.1	120.2	137.3	99.4	116.0	132.5	95.3	111.1	127.0	90.8	105.9	121.0	86.2	100.5	114.8	
		62	TC	127.5	127.5	130.7	121.6	121.6	128.0	115.1	115.1	125.2	108.4	108.4	122.4	101.7	101.7	117.7	
		62	SHC	92.6	111.7	130.7	90.0	109.0	128.0	87.3	106.2	125.2	84.5	103.4	122.4	80.7	99.2	117.7	
		67	TC	142.6	142.6	142.6	135.7	135.7	135.7	128.8	128.8	128.8	121.6	121.6	121.6	113.4	113.4	113.4	
		67	SHC	75.1	94.1	113.1	72.3	91.2	110.1	69.8	88.9	107.9	67.1	86.1	105.0	64.0	83.1	102.1	
	72	TC	158.8	158.8	158.8	151.4	151.4	151.4	143.9	143.9	143.9	135.7	135.7	135.7	126.8	126.8	126.8		
	72	SHC	57.4	76.0	94.5	54.8	73.5	92.2	52.2	71.0	89.8	49.4	68.1	86.9	46.4	65.2	84.1		
	76	TC	—	172.7	172.7	—	164.8	164.8	—	156.3	156.3	—	148.0	148.0	—	138.2	138.2		
	76	SHC	—	60.9	81.5	—	58.7	77.2	—	56.2	73.3	—	53.6	71.3	—	50.7	68.9		
	4375 cfm	EA (wb)	58	TC	128.4	128.4	146.4	123.7	123.7	141.0	118.4	118.4	135.0	113.0	113.0	128.8	106.6	106.6	121.5
			58	SHC	110.4	128.4	146.4	106.4	123.7	141.0	101.8	118.4	135.0	97.2	113.0	128.8	91.7	106.6	121.5
62			TC	132.3	132.3	145.4	126.1	126.1	142.4	119.8	119.8	138.3	113.9	113.9	131.4	107.7	107.7	125.3	
62			SHC	101.6	123.5	145.4	98.8	120.6	142.4	95.5	116.9	138.3	90.7	111.1	131.4	86.3	105.8	125.3	
67			TC	147.3	147.3	147.3	140.2	140.2	140.2	133.0	133.0	133.0	125.2	125.2	125.2	116.5	116.5	116.5	
67			SHC	80.9	102.8	124.7	78.4	100.4	122.5	75.7	97.7	119.7	72.6	94.5	116.4	69.8	92.0	114.1	
72		TC	163.6	163.6	163.6	156.3	156.3	156.3	148.0	148.0	148.0	139.4	139.4	139.4	130.2	130.2	130.2		
72		SHC	60.0	81.7	103.3	57.5	79.1	100.7	54.7	76.5	98.3	51.8	73.6	95.4	48.7	70.5	92.2		
76		TC	—	177.9	177.9	—	169.3	169.3	—	160.4	160.4	—	150.9	150.9	—	141.7	141.7		
76		SHC	—	64.3	83.8	—	61.8	82.2	—	59.1	79.9	—	56.3	77.4	—	53.5	74.8		
5000 cfm		EA (wb)	58	TC	134.8	134.8	153.5	129.4	129.4	147.3	124.2	124.2	141.4	118.2	118.2	134.6	111.7	111.7	127.2
			58	SHC	116.1	134.8	153.5	111.5	129.4	147.3	107.0	124.2	141.4	101.8	118.2	134.6	96.2	111.7	127.2
	62		TC	136.2	136.2	157.2	130.7	130.7	151.2	124.7	124.7	146.4	117.8	117.8	139.9	111.9	111.9	132.5	
	62		SHC	108.9	133.1	157.2	104.7	127.9	151.2	100.9	123.6	146.4	95.6	117.8	139.9	91.2	111.9	132.5	
	67		TC	150.7	150.7	150.7	143.6	143.6	143.6	135.9	135.9	135.9	127.6	127.6	127.6	119.0	119.0	124.9	
	67		SHC	86.2	111.1	135.9	83.4	108.1	132.8	80.7	105.3	130.0	77.6	102.3	126.9	75.0	100.0	124.9	
	72	TC	167.2	167.2	167.2	158.8	158.8	158.8	150.5	150.5	150.5	142.0	142.0	142.0	132.4	132.4	132.4		
	72	SHC	62.1	86.5	110.9	59.3	83.6	108.0	56.6	81.3	106.1	53.8	78.3	102.8	50.7	75.4	100.2		
	76	TC	—	180.9	180.9	—	172.1	172.1	—	163.4	163.4	—	153.8	153.8	—	143.9	143.9		
	76	SHC	—	66.7	89.7	—	64.1	87.5	—	61.6	85.4	—	58.7	82.8	—	55.8	79.9		
	5625 cfm	EA (wb)	58	TC	140.5	140.5	159.8	135.2	135.2	153.8	129.3	129.3	147.1	123.1	123.1	140.0	116.0	116.0	132.0
			58	SHC	121.3	140.5	159.8	116.7	135.2	153.8	111.6	129.3	147.1	106.2	123.1	140.0	100.1	116.0	132.0
62			TC	141.0	141.0	164.8	135.7	135.7	157.1	129.3	129.3	153.1	123.2	123.2	145.7	116.3	116.3	137.5	
62			SHC	114.2	139.5	164.8	109.1	133.1	157.1	105.5	129.3	153.1	100.7	123.2	145.7	95.0	116.3	137.5	
67			TC	153.9	153.9	153.9	146.4	146.4	146.4	138.4	138.4	141.7	130.4	130.4	138.0	120.7	120.7	134.8	
67			SHC	91.6	119.2	146.8	88.9	116.6	144.2	86.2	113.9	141.7	83.0	110.5	138.0	79.8	107.3	134.8	
72		TC	170.3	170.3	170.3	162.2	162.2	162.2	153.3	153.3	153.3	144.3	144.3	144.3	134.5	134.5	134.5		
72		SHC	64.1	91.4	118.7	61.5	88.8	116.2	58.6	86.2	113.7	55.7	83.1	110.4	52.6	80.0	107.4		
76		TC	—	183.9	183.9	—	174.5	174.5	—	166.1	166.1	—	155.4	155.4	—	145.8	145.8		
76		SHC	—	69.0	95.3	—	66.4	93.0	—	63.8	90.6	—	60.7	87.6	—	57.9	84.8		
6250 cfm		EA (wb)	58	TC	145.2	145.2	164.9	139.7	139.7	158.7	133.4	133.4	151.5	125.9	125.9	143.1	118.7	118.7	134.9
			58	SHC	125.4	145.2	164.9	120.6	139.7	158.7	115.2	133.4	151.5	108.8	125.9	143.1	102.6	118.7	134.9
	62		TC	145.2	145.2	171.6	139.8	139.8	165.2	133.7	133.7	157.9	126.6	126.6	149.6	119.5	119.5	141.2	
	62		SHC	118.9	145.2	171.6	114.4	139.8	165.2	109.4	133.7	157.9	103.6	126.6	149.6	97.8	119.5	141.2	
	67		TC	156.2	156.2	156.2	148.6	148.6	153.4	140.3	140.3	150.7	131.6	131.6	147.3	122.8	122.8	143.7	
	67		SHC	96.0	126.0	156.0	93.3	123.3	153.4	90.5	120.6	150.7	87.4	117.4	147.3	84.2	114.0	143.7	
	72	TC	172.5	172.5	172.5	164.3	164.3	164.3	155.3	155.3	155.3	146.1	146.1	146.1	136.0	136.0	136.0		
	72	SHC	65.8	95.7	125.6	63.1	93.1	123.1	60.3	90.2	120.2	57.3	87.2	117.0	54.2	84.2	114.1		
	76	TC	—	186.0	186.0	—	177.5	177.5	—	167.2	167.2	—	157.3	157.3	—	147.0	147.0		
	76	SHC	—	71.0	100.2	—	68.5	97.7	—	65.4	94.7	—	62.6	92.2	—	59.6	89.2		

LEGEND

- db — dry bulb
- EA — Entering Air Temperature (°F)
- SHC — Sensible Heat Capacity (1000 Btuh) gross
- TC — Total Capacity (1000 Btuh) gross
- wb — wet bulb

38AUD14/40RUA14 Stage 2 Combination Ratings — 60 Hz

38AUD14/40RUA14			AMBIENT TEMPERATURE (°F)																
			85			95			105			115			125				
			EA (db)			EA (db)			EA (db)			EA (db)			EA (db)				
			75	80	85	75	80	85	75	80	85	75	80	85	75	80	85		
3150 cfm	EA (wb)	58	TC	107.3	107.3	120.2	103.2	103.2	115.8	98.5	98.5	111.6	93.7	93.7	106.2	88.3	88.3	100.1	
			SHC	92.3	106.2	120.2	88.8	102.3	115.8	85.4	98.5	111.6	81.2	93.7	106.2	76.6	88.3	100.1	
		62	TC	112.6	112.6	114.7	107.4	107.4	112.0	101.7	101.7	108.6	96.1	96.1	104.6	89.9	89.9	99.9	
			SHC	83.4	99.0	114.7	80.8	96.4	112.0	77.7	93.1	108.6	74.5	89.5	104.6	70.7	85.3	99.9	
		67	TC	124.5	124.5	124.5	118.7	118.7	118.7	112.6	112.6	112.6	105.8	105.8	105.8	98.4	98.4	98.4	
			SHC	68.0	83.5	99.1	65.7	81.2	96.8	63.2	78.8	94.4	60.5	76.1	91.8	57.6	73.3	88.9	
	72	TC	137.5	137.5	137.5	131.4	131.4	131.4	124.6	124.6	124.6	117.2	117.2	117.2	109.1	109.1	109.1		
		SHC	52.7	67.7	82.6	50.4	65.5	80.6	47.8	63.1	78.4	45.1	60.5	75.9	42.2	57.7	73.2		
	76	TC	—	148.8	148.8	—	142.2	142.2	—	135.0	135.0	—	126.9	126.9	—	118.2	118.2		
		SHC	—	54.8	72.1	—	52.3	67.7	—	50.0	65.7	—	47.6	63.6	—	45.0	59.5		
	3750 cfm	EA (wb)	58	TC	113.7	113.7	128.8	109.4	109.4	123.9	104.7	104.7	118.5	99.4	99.4	112.5	93.5	93.5	105.9
				SHC	98.7	113.7	128.8	95.0	109.4	123.9	90.8	104.7	118.5	86.2	99.4	112.5	81.1	93.5	105.9
62			TC	117.4	117.4	124.9	112.0	112.0	122.0	106.5	106.5	118.0	100.4	100.4	114.0	94.0	94.0	109.0	
			SHC	89.6	107.2	124.9	87.0	104.5	122.0	83.7	100.9	118.0	80.3	97.1	114.0	76.6	92.8	109.0	
67			TC	128.7	128.7	128.7	122.6	122.6	122.6	116.1	116.1	116.1	108.9	108.9	108.9	101.2	101.2	101.2	
			SHC	73.0	91.2	109.5	70.6	88.8	107.1	68.0	86.4	104.7	65.3	83.6	102.0	62.4	80.7	99.1	
72		TC	141.8	141.8	141.8	135.2	135.2	135.2	128.1	128.1	128.1	120.4	120.4	120.4	111.9	111.9	111.9		
		SHC	54.6	72.5	90.3	52.3	70.2	88.2	49.7	67.8	85.9	47.0	65.1	83.3	44.0	62.2	80.5		
76		TC	—	153.3	153.3	—	146.2	146.2	—	138.4	138.4	—	130.1	130.1	—	121.0	121.0		
		SHC	—	57.1	75.7	—	55.0	73.7	—	52.6	69.3	—	50.0	67.3	—	47.3	64.9		
4400 cfm		EA (wb)	58	TC	119.8	119.8	135.6	115.1	115.1	130.3	110.0	110.0	124.5	104.3	104.3	118.1	98.1	98.1	111.0
				SHC	104.0	119.8	135.6	100.0	115.1	130.3	95.4	110.0	124.5	90.6	104.3	118.1	85.1	98.1	111.0
	62		TC	121.6	121.6	135.4	116.3	116.3	132.0	110.5	110.5	127.9	104.6	104.6	121.6	98.5	98.5	114.3	
			SHC	96.0	115.7	135.4	93.1	112.6	132.0	89.9	108.9	127.9	85.5	103.5	121.6	80.3	97.3	114.3	
	67		TC	132.0	132.0	132.0	125.7	125.7	125.7	118.8	118.8	118.8	111.5	111.5	112.4	103.3	103.3	109.1	
			SHC	77.9	99.0	120.1	75.5	96.6	117.8	72.9	94.1	115.2	70.1	91.3	112.4	67.0	88.0	109.1	
	72	TC	145.2	145.2	145.2	138.4	138.4	138.4	131.0	131.0	131.0	122.8	122.8	122.8	114.0	114.0	114.0		
		SHC	56.5	77.3	98.1	54.1	74.9	95.8	51.5	72.5	93.4	48.7	69.7	90.7	45.8	66.8	87.8		
	76	TC	—	156.7	156.7	—	149.3	149.3	—	141.2	141.2	—	132.6	132.6	—	123.3	123.3		
		SHC	—	59.5	78.7	—	57.3	77.0	—	54.8	75.0	—	52.2	72.6	—	49.4	70.0		
	5000 cfm	EA (wb)	58	TC	124.4	124.4	140.8	119.5	119.5	135.2	114.1	114.1	129.1	108.0	108.0	122.3	101.5	101.5	114.9
				SHC	108.1	124.4	140.8	103.7	119.5	135.2	99.0	114.1	129.1	93.8	108.0	122.3	88.1	101.5	114.9
62			TC	125.1	125.1	144.4	119.6	119.6	140.2	114.3	114.3	133.5	108.1	108.1	127.1	101.6	101.6	119.4	
			SHC	101.7	123.1	144.4	98.4	119.3	140.2	93.8	113.6	133.5	89.2	108.1	127.1	83.8	101.6	119.4	
67			TC	134.4	134.4	134.4	127.9	127.9	127.9	120.7	120.7	124.3	113.3	113.3	121.3	105.0	105.0	116.5	
			SHC	82.3	105.9	129.6	79.8	103.5	127.1	77.1	100.7	124.3	74.3	97.8	121.3	70.4	93.5	116.5	
72		TC	147.7	147.7	147.7	140.6	140.6	140.6	133.0	133.0	133.0	124.6	124.6	124.6	115.6	115.6	115.6		
		SHC	58.0	81.4	104.8	55.6	79.0	102.5	53.0	76.5	100.0	50.2	73.7	97.3	47.2	70.8	94.3		
76		TC	—	159.1	159.1	—	151.5	151.5	—	143.2	143.2	—	134.4	134.4	—	124.9	124.9		
		SHC	—	61.5	83.8	—	59.1	81.8	—	56.7	79.5	—	54.0	77.1	—	51.2	74.4		
5650 cfm		EA (wb)	58	TC	128.6	128.6	145.4	123.4	123.4	139.6	117.7	117.7	133.2	111.5	111.5	126.1	104.6	104.6	118.3
				SHC	111.7	128.6	145.4	107.2	123.4	139.6	102.3	117.7	133.2	96.8	111.5	126.1	90.8	104.6	118.3
	62		TC	129.3	129.3	149.4	124.0	124.0	143.3	117.8	117.8	138.4	111.6	111.6	131.1	104.7	104.7	123.0	
			SHC	105.4	127.4	149.4	101.0	122.1	143.3	97.2	117.8	138.4	92.0	111.6	131.1	86.3	104.7	123.0	
	67		TC	136.4	136.4	139.2	129.8	129.8	136.5	122.5	122.5	133.2	114.7	114.7	129.3	106.9	106.9	123.6	
			SHC	86.7	113.0	139.2	84.2	110.3	136.5	81.2	107.2	133.2	77.9	103.6	129.3	73.8	98.7	123.6	
	72	TC	149.8	149.8	149.8	142.5	142.5	142.5	134.7	134.7	134.7	126.1	126.1	126.1	116.9	116.9	116.9		
		SHC	59.5	85.6	111.7	57.1	83.2	109.4	54.5	80.7	106.9	51.7	77.9	104.1	48.7	74.9	101.1		
	76	TC	—	161.2	161.2	—	153.4	153.4	—	145.0	145.0	—	136.0	136.0	—	126.2	126.2		
		SHC	—	63.3	88.5	—	60.9	86.4	—	58.4	84.1	—	55.7	81.5	—	52.8	78.7		

LEGEND

- db — dry bulb
- EA — Entering Air Temperature (°F)
- SHC — Sensible Heat Capacity (1000 Btuh) gross
- TC — Total Capacity (1000 Btuh) gross
- wb — wet bulb

38AUD14/40RUA14 Stage 1 Combination Ratings — 60 Hz

38AUD14/40RUA14			AMBIENT TEMPERATURE (°F)																
			85			95			105			115			125				
			EA (db)			EA (db)			EA (db)			EA (db)			EA (db)				
			75	80	85	75	80	85	75	80	85	75	80	85	75	80	85		
3150 cfm	EA (wb)	58	TC	46.3	46.3	58.6	44.6	44.6	56.5	42.6	42.6	53.9	40.3	40.3	51.1	37.7	37.7	47.7	
			SHC	34.0	46.3	58.6	32.8	44.6	56.5	31.3	42.6	53.9	29.6	40.3	51.1	27.6	37.7	47.7	
		62	TC	47.8	47.8	59.3	45.6	45.6	58.2	43.0	43.0	56.9	40.5	40.5	54.9	38.0	38.0	50.5	
			SHC	29.6	44.4	59.3	28.6	43.4	58.2	27.4	42.2	56.9	26.1	40.5	54.9	24.2	37.3	50.5	
		67	TC	53.3	53.3	53.3	50.7	50.7	50.7	47.8	47.8	49.6	44.7	44.7	48.5	41.2	41.2	47.4	
			SHC	22.0	36.8	51.7	21.0	35.8	50.6	19.9	34.8	49.6	18.7	33.6	48.5	17.5	32.4	47.4	
	72	TC	59.2	59.2	59.2	56.4	56.4	56.4	53.3	53.3	53.3	49.8	49.8	49.8	46.1	46.1	46.1		
		SHC	14.6	29.1	43.5	13.5	28.1	42.7	12.4	27.0	41.7	11.2	25.9	40.6	9.8	24.6	39.4		
	76	TC	—	64.2	64.2	—	61.3	61.3	—	57.8	57.8	—	54.5	54.5	—	50.2	50.2		
		SHC	—	22.5	39.9	—	21.7	34.2	—	20.5	33.5	—	19.6	33.5	—	18.4	32.7		
	3750 cfm	EA (wb)	58	TC	49.2	49.2	62.2	47.2	47.2	59.7	45.2	45.2	57.1	42.6	42.6	53.8	39.9	39.9	50.4
				SHC	36.3	49.2	62.2	34.8	47.2	59.7	33.2	45.2	57.1	31.3	42.6	53.8	29.3	39.9	50.4
62			TC	49.7	49.7	65.6	48.0	48.0	62.5	45.2	45.2	61.1	42.7	42.7	57.8	40.1	40.1	54.2	
			SHC	31.9	48.7	65.6	30.5	46.5	62.5	29.3	45.2	61.1	27.7	42.7	57.8	25.9	40.1	54.2	
67			TC	54.8	54.8	58.2	52.2	52.2	56.7	49.2	49.2	55.7	46.0	46.0	54.4	42.5	42.5	52.9	
			SHC	23.1	40.7	58.2	22.0	39.4	56.7	21.0	38.3	55.7	19.8	37.1	54.4	18.5	35.7	52.9	
72		TC	60.7	60.7	60.7	57.9	57.9	57.9	54.5	54.5	54.5	51.0	51.0	51.0	47.2	47.2	47.2		
		SHC	14.1	31.0	47.8	13.1	29.9	46.7	11.9	28.9	45.9	10.6	28.0	45.4	9.4	26.7	44.0		
76		TC	—	66.1	66.1	—	62.9	62.9	—	59.0	59.0	—	55.5	55.5	—	51.4	51.4		
		SHC	—	23.6	39.1	—	22.7	38.7	—	21.5	37.8	—	20.5	37.2	—	19.2	36.2		
4400 cfm		EA (wb)	58	TC	51.9	51.9	65.5	49.8	49.8	62.9	47.5	47.5	60.0	44.8	44.8	56.7	42.0	42.0	53.1
				SHC	38.3	51.9	65.5	36.8	49.8	62.9	35.0	47.5	60.0	33.0	44.8	56.7	30.9	42.0	53.1
	62		TC	51.9	51.9	70.0	49.8	49.8	67.2	47.7	47.7	64.4	44.9	44.9	60.6	41.8	41.8	56.5	
			SHC	33.8	51.9	70.0	32.4	49.8	67.2	31.0	47.7	64.4	29.1	44.9	60.6	27.1	41.8	56.5	
	67		TC	56.2	56.2	63.8	53.3	53.3	62.6	50.4	50.4	62.1	47.0	47.0	60.2	43.2	43.2	59.3	
			SHC	24.1	43.9	63.8	23.0	42.8	62.6	22.1	42.1	62.1	20.8	40.5	60.2	19.6	39.5	59.3	
	72	TC	62.0	62.0	62.0	59.0	59.0	59.0	55.7	55.7	55.7	52.1	52.1	52.1	48.1	48.1	48.5		
		SHC	13.5	33.1	52.7	12.4	32.3	52.1	11.3	31.1	51.0	10.1	30.0	49.9	8.8	28.7	48.5		
	76	TC	—	67.5	67.5	—	64.0	64.0	—	60.4	60.4	—	56.6	56.6	—	52.0	52.0		
		SHC	—	24.4	43.0	—	23.4	42.5	—	22.4	41.6	—	21.3	40.8	—	20.0	39.7		
	5000 cfm	EA (wb)	58	TC	53.7	53.7	67.8	51.6	51.6	65.1	49.2	49.2	62.1	46.5	46.5	58.7	43.3	43.3	54.6
				SHC	39.7	53.7	67.8	38.1	51.6	65.1	36.3	49.2	62.1	34.3	46.5	58.7	31.9	43.3	54.6
62			TC	53.9	53.9	72.6	51.6	51.6	69.6	49.0	49.0	66.1	46.5	46.5	62.7	43.3	43.3	58.4	
			SHC	35.1	53.9	72.6	33.7	51.6	69.6	31.9	49.0	66.1	30.3	46.5	62.7	28.1	43.3	58.4	
67			TC	57.2	57.2	69.4	54.3	54.3	68.9	51.1	51.1	67.0	47.6	47.6	65.7	43.9	43.9	64.2	
			SHC	25.0	47.2	69.4	24.1	46.5	68.9	22.9	45.0	67.0	21.8	43.8	65.7	20.6	42.4	64.2	
72		TC	63.1	63.1	63.1	60.0	60.0	60.0	56.6	56.6	56.6	52.8	52.8	53.9	48.7	48.7	52.6		
		SHC	12.9	35.0	57.1	11.9	34.0	56.1	10.7	32.9	55.1	9.5	31.7	53.9	8.3	30.4	52.6		
76		TC	—	68.1	68.1	—	64.7	64.7	—	61.2	61.2	—	57.1	57.1	—	53.1	53.1		
		SHC	—	25.0	46.3	—	24.0	45.8	—	22.9	44.6	—	21.8	43.7	—	20.6	42.6		
5650 cfm		EA (wb)	58	TC	55.2	55.2	69.5	53.2	53.2	67.1	50.7	50.7	64.0	47.4	47.4	59.8	44.2	44.2	55.8
				SHC	40.8	55.2	69.5	39.4	53.2	67.1	37.5	50.7	64.0	35.0	47.4	59.8	32.7	44.2	55.8
	62		TC	55.7	55.7	75.0	53.3	53.3	71.8	50.5	50.5	68.0	47.8	47.8	64.5	44.5	44.5	60.0	
			SHC	36.4	55.7	75.0	34.8	53.3	71.8	32.9	50.5	68.0	31.2	47.8	64.5	29.0	44.5	60.0	
	67		TC	58.1	58.1	74.8	55.1	55.1	73.5	51.8	51.8	72.4	48.3	48.3	70.5	45.2	45.2	65.6	
			SHC	26.0	50.4	74.8	25.0	49.2	73.5	23.9	48.2	72.4	22.7	46.6	70.5	21.1	43.3	65.6	
	72	TC	64.0	64.0	64.0	60.8	60.8	60.8	57.2	57.2	59.2	53.4	53.4	58.0	49.2	49.2	56.6		
		SHC	12.2	36.6	61.1	11.2	35.8	60.3	10.1	34.6	59.2	8.9	33.4	58.0	7.7	32.1	56.6		
	76	TC	—	69.2	69.2	—	65.9	65.9	—	61.9	61.9	—	57.8	57.8	—	53.3	53.3		
		SHC	—	25.4	49.4	—	24.5	48.5	—	23.4	47.7	—	22.2	46.6	—	20.9	45.4		

LEGEND

- db — dry bulb
- EA — Entering Air Temperature (°F)
- SHC — Sensible Heat Capacity (1000 Btuh) gross
- TC — Total Capacity (1000 Btuh) gross
- wb — wet bulb

38AUZ16/40RUA16 Stage 2 Combination Ratings — 60 Hz

38AUZ16/40RUA16			AMBIENT TEMPERATURE (°F)																
			85			95			105			115			125				
			EA (db)			EA (db)			EA (db)			EA (db)			EA (db)				
			75	80	85	75	80	85	75	80	85	75	80	85	75	80	85		
4500 cfm	EA (wb)	58	TC	155.2	155.2	168.9	146.6	146.6	169.0	140.8	140.8	162.3	134.7	134.7	155.2	128.1	128.1	147.6	
			SHC	126.1	147.5	168.9	124.3	146.6	169.0	119.4	140.8	162.3	114.2	134.7	155.2	108.6	128.1	147.6	
		62	TC	165.9	165.9	165.9	158.2	158.2	158.4	150.1	150.1	155.0	141.5	141.5	151.3	132.4	132.4	147.4	
			SHC	113.6	137.7	161.7	110.4	134.4	158.4	107.0	131.0	155.0	103.4	127.3	151.3	99.6	123.5	147.4	
		67	TC	187.3	187.3	187.3	178.9	178.9	178.9	170.0	170.0	170.0	160.4	160.4	160.4	150.2	150.2	150.2	
			SHC	92.8	117.0	141.1	89.6	113.7	137.9	86.2	110.4	134.5	82.7	106.8	130.9	79.0	103.1	127.2	
	72	TC	210.6	210.6	210.6	201.4	201.4	201.4	191.6	191.6	191.6	181.2	181.2	181.2	170.0	170.0	170.0		
		SHC	71.6	95.9	120.3	68.4	92.8	117.1	65.1	89.4	113.7	61.6	85.9	110.1	57.9	82.2	106.4		
	76	TC	—	230.5	230.5	—	220.6	220.6	—	210.0	210.0	—	198.8	198.8	—	186.6	186.6		
		SHC	—	78.8	103.5	—	75.6	100.4	—	72.3	97.1	—	68.9	93.6	—	65.2	89.9		
	5250 cfm	EA (wb)	58	TC	164.0	164.0	188.4	158.0	158.0	181.5	151.6	151.6	174.2	144.8	144.8	166.4	137.4	137.4	157.9
				SHC	139.5	164.0	188.4	134.4	158.0	181.5	129.0	151.6	174.2	123.2	144.8	166.4	117.0	137.4	157.9
62			TC	173.0	173.0	181.0	164.9	164.9	177.5	156.4	156.4	173.7	147.4	147.4	169.5	138.1	138.1	164.3	
			SHC	125.5	153.2	181.0	122.1	149.8	177.5	118.5	146.1	173.7	114.6	142.0	169.5	110.2	137.3	164.3	
67			TC	194.7	194.7	194.7	185.7	185.7	185.7	176.1	176.1	176.1	166.0	166.0	166.0	155.1	155.1	155.1	
			SHC	100.7	128.7	156.6	97.4	125.3	153.3	93.9	121.8	149.8	90.2	118.1	146.1	86.4	114.3	142.2	
72		TC	218.2	218.2	218.2	208.5	208.5	208.5	198.1	198.1	198.1	186.9	186.9	186.9	175.1	175.1	175.1		
		SHC	75.4	103.6	131.8	72.2	100.3	128.4	68.7	96.8	124.9	65.0	93.1	121.2	61.2	89.3	117.4		
76		TC	—	238.3	238.3	—	227.8	227.8	—	216.6	216.6	—	204.7	204.7	—	191.8	191.8		
		SHC	—	83.3	112.2	—	80.0	108.7	—	76.5	105.1	—	72.9	101.4	—	69.0	97.5		
6000 cfm		EA (wb)	58	TC	174.0	174.0	199.5	167.5	167.5	192.0	160.6	160.6	184.1	153.2	153.2	175.6	145.3	145.3	166.5
				SHC	148.5	174.0	199.5	143.0	167.5	192.0	137.1	160.6	184.1	130.8	153.2	175.6	124.0	145.3	166.5
	62		TC	179.1	179.1	199.2	170.6	170.6	195.1	162.4	162.4	189.1	153.4	153.4	183.3	145.5	145.5	173.8	
			SHC	136.7	168.0	199.2	132.9	164.0	195.1	128.2	158.7	189.1	123.6	153.4	183.3	117.2	145.5	173.8	
	67		TC	200.3	200.3	200.3	190.9	190.9	190.9	180.8	180.8	180.8	170.2	170.2	170.2	158.9	158.9	158.9	
			SHC	108.1	139.8	171.5	104.6	136.3	168.0	101.0	132.7	164.4	97.3	129.0	160.6	93.4	125.0	156.6	
	72	TC	224.1	224.1	224.1	213.9	213.9	213.9	203.0	203.0	203.0	191.4	191.4	191.4	178.9	178.9	178.9		
		SHC	78.7	110.6	142.5	75.3	107.2	139.1	71.7	103.6	135.5	68.0	99.9	131.7	64.1	95.9	127.8		
	76	TC	—	244.3	244.3	—	233.3	233.3	—	221.7	221.7	—	209.2	209.2	—	195.8	195.8		
		SHC	—	87.0	119.5	—	83.6	116.1	—	80.1	112.5	—	76.3	108.6	—	72.4	104.6		
	6750 cfm	EA (wb)	58	TC	182.6	182.6	209.0	175.7	175.7	201.1	168.3	168.3	192.6	160.3	160.3	183.5	151.8	151.8	173.8
				SHC	156.2	182.6	209.0	150.3	175.7	201.1	143.9	168.3	192.6	137.2	160.3	183.5	129.9	151.8	173.8
62			TC	184.3	184.3	215.4	176.0	176.0	209.8	168.5	168.5	200.9	160.6	160.6	191.4	152.1	152.1	181.3	
			SHC	146.7	181.0	215.4	142.2	176.0	209.8	136.1	168.5	200.9	129.7	160.6	191.4	122.9	152.1	181.3	
67			TC	204.8	204.8	204.8	195.0	195.0	195.0	184.6	184.6	184.6	173.6	173.6	174.6	162.0	162.0	170.4	
			SHC	115.0	150.4	185.8	111.5	146.9	182.3	107.9	143.2	178.6	104.0	139.3	174.6	100.0	135.2	170.4	
72		TC	228.8	228.8	228.8	218.2	218.2	218.2	206.8	206.8	206.8	194.8	194.8	194.8	182.0	182.0	182.0		
		SHC	81.5	117.2	152.8	78.1	113.7	149.3	74.5	110.1	145.7	70.7	106.3	141.8	66.7	102.2	137.8		
76		TC	—	249.1	249.1	—	237.7	237.7	—	225.6	225.6	—	212.8	212.8	—	199.0	199.0		
		SHC	—	90.3	126.5	—	86.9	123.0	—	83.2	119.3	—	79.4	115.4	—	75.4	111.3		
7500 cfm		EA (wb)	58	TC	190.0	190.0	217.1	182.7	182.7	208.8	174.8	174.8	199.8	166.4	166.4	190.2	157.5	157.5	180.0
				SHC	162.8	190.0	217.1	156.6	182.7	208.8	149.8	174.8	199.8	142.7	166.4	190.2	135.0	157.5	180.0
	62		TC	192.7	192.7	218.5	182.9	182.9	217.7	175.0	175.0	208.3	166.7	166.7	198.3	157.6	157.6	187.6	
			SHC	150.4	184.5	218.5	148.1	182.9	217.7	141.8	175.0	208.3	135.0	166.7	198.3	127.7	157.6	187.6	
	67		TC	208.5	208.5	208.5	198.4	198.4	198.4	187.7	187.7	192.2	176.5	176.5	188.1	164.6	164.6	183.6	
			SHC	121.6	160.6	199.7	118.1	157.1	196.0	114.4	153.3	192.2	110.5	149.3	188.1	106.4	145.0	183.6	
	72	TC	232.6	232.6	232.6	221.6	221.6	221.6	210.0	210.0	210.0	197.7	197.7	197.7	184.5	184.5	184.5		
		SHC	84.1	123.4	162.7	80.6	119.9	159.1	76.9	116.2	155.4	73.1	112.3	151.6	69.1	108.3	147.5		
	76	TC	—	253.0	253.0	—	241.3	241.3	—	228.9	228.9	—	215.7	215.7	—	201.6	201.6		
		SHC	—	93.3	133.1	—	89.7	129.5	—	86.1	125.8	—	82.2	121.8	—	78.1	117.7		

LEGEND

- db — dry bulb
- EA — Entering Air Temperature (°F)
- SHC — Sensible Heat Capacity (1000 Btuh) gross
- TC — Total Capacity (1000 Btuh) gross
- wb — wet bulb

38AUZ16/40RUA16 Stage 1 Combination Ratings — 60 Hz

38AUZ16/40RUA16				AMBIENT TEMPERATURE (°F)															
				85			95			105			115			125			
				EA (db)			EA (db)			EA (db)			EA (db)			EA (db)			
				75	80	85	75	80	85	75	80	85	75	80	85	75	80	85	
3750 cfm	EA (wb)	58	TC	102.6	102.6	117.0	95.7	95.7	109.6	88.6	88.6	101.9	81.1	81.1	93.8	73.2	73.2	85.2	
			SHC	88.1	102.6	117.0	81.8	95.7	109.6	75.3	88.6	101.9	68.4	81.1	93.8	61.2	73.2	85.2	
		62	TC	102.7	102.7	121.9	95.9	95.9	114.4	88.8	88.8	106.5	81.2	81.2	98.1	73.3	73.3	89.2	
			SHC	83.5	102.7	121.9	77.4	95.9	114.4	71.0	88.8	106.5	64.4	81.2	98.1	57.4	73.3	89.2	
		67	TC	112.4	112.4	124.1	104.1	104.1	124.1	95.4	95.4	107.0	86.4	86.4	92.0	76.8	76.8	86.8	
			SHC	65.6	86.2	106.8	60.8	81.4	102.0	55.9	76.4	97.0	50.9	71.4	92.0	45.7	66.3	86.8	
	72	TC	125.2	125.2	125.2	116.5	116.5	116.5	107.3	107.3	107.3	97.6	97.6	97.6	87.4	87.4	87.4		
		SHC	45.3	66.0	86.6	40.5	61.1	81.7	35.5	56.0	76.6	30.4	51.0	71.6	25.1	45.7	66.3		
	76	TC	—	136.2	136.2	—	127.2	127.2	—	117.6	117.6	—	107.5	107.5	—	96.9	96.9		
		SHC	—	49.7	70.3	—	44.8	65.4	—	39.8	60.4	—	34.6	55.3	—	29.3	50.0		
	4500 cfm	EA (wb)	58	TC	109.4	109.4	124.6	102.3	102.3	116.9	94.7	94.7	108.6	86.7	86.7	100.0	78.3	78.3	90.8
				SHC	94.2	109.4	124.6	87.7	102.3	116.9	80.7	94.7	108.6	73.4	86.7	100.0	65.7	78.3	90.8
62			TC	109.6	109.6	129.8	102.5	102.5	121.9	94.8	94.8	113.4	86.8	86.8	104.5	78.4	78.4	95.0	
			SHC	89.3	109.6	129.8	83.0	102.5	121.9	76.2	94.8	113.4	69.1	86.8	104.5	61.7	78.4	95.0	
67			TC	115.5	115.5	122.1	107.0	107.0	117.3	98.1	98.1	112.4	88.7	88.7	107.3	78.9	78.9	102.0	
			SHC	72.9	97.5	122.1	68.1	92.7	117.3	63.2	87.8	112.4	58.2	82.7	107.3	53.0	77.5	102.0	
72		TC	128.4	128.4	128.4	119.4	119.4	119.4	110.0	110.0	110.0	100.0	100.0	100.0	89.4	89.4	89.4		
		SHC	47.8	72.5	97.3	42.9	67.6	92.3	37.9	62.6	87.3	32.7	57.4	82.2	27.4	52.1	76.9		
76		TC	—	139.7	139.7	—	130.3	130.3	—	120.4	120.4	—	110.0	110.0	—	99.1	99.1		
		SHC	—	52.4	77.2	—	47.5	72.2	—	42.4	67.2	—	37.2	61.9	—	31.8	56.5		
5250 cfm		EA (wb)	58	TC	115.1	115.1	130.9	107.5	107.5	122.7	99.6	99.6	114.1	91.1	91.1	104.9	82.2	82.2	95.2
				SHC	99.2	115.1	130.9	92.3	107.5	122.7	85.0	99.6	114.1	77.4	91.1	104.9	69.3	82.2	95.2
	62		TC	115.1	115.1	136.1	107.6	107.6	127.8	99.7	99.7	119.0	91.2	91.2	109.5	82.3	82.3	99.6	
			SHC	94.0	115.1	136.1	87.3	107.6	127.8	80.4	99.7	119.0	72.9	91.2	109.5	65.1	82.3	99.6	
	67		TC	117.8	117.8	137.3	109.2	109.2	132.5	100.1	100.1	127.2	91.4	91.4	118.8	82.5	82.5	108.2	
			SHC	80.1	108.7	137.3	75.3	103.9	132.5	70.4	98.8	127.2	64.0	91.4	118.8	56.7	82.5	108.2	
	72	TC	130.7	130.7	130.7	121.5	121.5	121.5	111.8	111.8	111.8	101.6	101.6	101.6	90.8	90.8	90.8		
		SHC	49.9	78.8	107.6	45.0	73.8	102.7	40.0	68.8	97.6	34.9	63.6	92.4	29.6	58.4	87.1		
	76	TC	—	142.2	142.2	—	132.6	132.6	—	122.5	122.5	—	111.9	111.9	—	100.7	100.7		
		SHC	—	54.7	83.6	—	49.7	78.6	—	44.5	73.4	—	39.3	68.2	—	33.8	62.6		
	6000 cfm	EA (wb)	58	TC	119.6	119.6	135.9	111.7	111.7	127.4	103.4	103.4	118.3	94.6	94.6	108.8	85.5	85.5	98.8
				SHC	103.3	119.6	135.9	96.1	111.7	127.4	88.4	103.4	118.3	80.5	94.6	108.8	72.1	85.5	98.8
62			TC	119.6	119.6	141.3	111.7	111.7	132.5	103.6	103.6	123.4	94.8	94.8	113.6	85.5	85.5	103.3	
			SHC	97.9	119.6	141.3	90.9	111.7	132.5	83.7	103.6	123.4	76.0	94.8	113.6	67.8	85.5	103.3	
67			TC	119.9	119.9	151.6	111.9	111.9	143.0	103.7	103.7	133.4	94.9	94.9	123.0	85.7	85.7	112.1	
			SHC	87.1	119.4	151.6	80.8	111.9	143.0	74.0	103.7	133.4	66.8	94.9	123.0	59.2	85.7	112.1	
72		TC	132.4	132.4	132.4	123.1	123.1	123.1	113.2	113.2	113.2	102.8	102.8	102.8	91.9	91.9	97.3		
		SHC	52.0	84.8	117.7	47.1	79.9	112.7	42.1	74.9	107.7	37.1	69.8	102.6	32.0	64.6	97.3		
76		TC	—	144.0	144.0	—	134.3	134.3	—	124.0	124.0	—	113.2	113.2	—	101.9	101.9		
		SHC	—	56.6	89.6	—	51.5	84.4	—	46.3	79.2	—	40.9	73.7	—	35.3	67.8		
6750 cfm		EA (wb)	58	TC	123.1	123.1	139.9	115.1	115.1	131.1	106.6	106.6	121.9	97.6	97.6	112.1	88.1	88.1	101.7
				SHC	106.4	123.1	139.9	99.0	115.1	131.1	91.3	106.6	121.9	83.1	97.6	112.1	74.5	88.1	101.7
	62		TC	123.3	123.3	145.5	115.4	115.4	136.7	106.8	106.8	127.2	97.7	97.7	116.9	88.2	88.2	106.3	
			SHC	101.0	123.3	145.5	94.0	115.4	136.7	86.5	106.8	127.2	78.4	97.7	116.9	70.1	88.2	106.3	
	67		TC	123.4	123.4	156.7	115.3	115.3	147.2	106.8	106.8	137.2	97.8	97.8	126.6	88.3	88.3	115.3	
			SHC	90.2	123.4	156.7	83.5	115.3	147.2	76.5	106.8	137.2	69.1	97.8	126.6	61.3	88.3	115.3	
	72	TC	133.7	133.7	133.7	124.3	124.3	124.3	114.2	114.2	117.8	103.7	103.7	112.9	92.7	92.7	108.1		
		SHC	54.1	90.9	127.7	49.2	86.0	122.8	44.4	81.1	117.8	39.5	76.2	112.9	34.7	71.4	108.1		
	76	TC	—	145.5	145.5	—	135.6	135.6	—	125.2	125.2	—	114.3	114.3	—	102.9	102.9		
		SHC	—	58.0	94.9	—	52.8	89.6	—	47.5	84.2	—	41.9	78.4	—	36.1	72.3		

LEGEND

- db — dry bulb
- EA — Entering Air Temperature (°F)
- SHC — Sensible Heat Capacity (1000 Btuh) gross
- TC — Total Capacity (1000 Btuh) gross
- wb — wet bulb

38AUD16/40RUA16 Stage 3 Combination Ratings — 60 Hz

38AUD16/40RUA16				AMBIENT TEMPERATURE (°F)															
				85			95			105			115			125			
				EA (db)			EA (db)			EA (db)			EA (db)			EA (db)			
				75	80	85	75	80	85	75	80	85	75	80	85	75	80	85	
4500 cfm	EA (wb)	58	TC	167.6	167.6	185.4	161.3	161.3	180.5	154.6	154.6	174.8	147.9	147.9	167.2	140.7	140.7	159.1	
			SHC	143.3	164.4	185.4	139.1	159.8	180.5	134.4	154.6	174.8	128.6	147.9	167.2	122.3	140.7	159.1	
		62	TC	177.9	177.9	177.9	170.1	170.1	170.4	166.5	166.5	166.5	153.3	153.3	162.7	144.1	144.1	158.2	
			SHC	128.6	151.2	173.9	125.1	147.8	170.4	118.5	139.9	161.3	117.4	140.0	162.7	113.2	135.7	158.2	
		67	TC	195.6	195.6	195.6	187.3	187.3	187.3	178.3	178.3	178.3	168.8	168.8	168.8	158.7	158.7	158.7	
			SHC	105.8	128.2	150.7	102.4	124.9	147.5	98.7	121.4	144.0	94.9	117.7	140.4	91.0	113.8	136.6	
	72	TC	215.9	215.9	215.9	206.7	206.7	206.7	196.9	196.9	196.9	186.4	186.4	186.4	175.3	175.3	175.3		
		SHC	83.4	105.1	126.7	79.8	101.8	123.7	76.1	98.2	120.4	72.2	94.5	116.9	68.1	90.6	113.2		
	76	TC	—	233.6	233.6	—	223.7	223.7	—	212.9	212.9	—	201.6	201.6	—	189.4	189.4		
		SHC	—	85.1	109.9	—	81.9	106.6	—	78.9	103.7	—	75.5	95.0	—	71.7	92.8		
	5350 cfm	EA (wb)	58	TC	176.0	176.0	198.9	169.7	169.7	191.8	163.0	163.0	184.2	155.8	155.8	176.1	148.0	148.0	167.3
				SHC	153.1	176.0	198.9	147.6	169.7	191.8	141.8	163.0	184.2	135.5	155.8	176.1	128.7	148.0	167.3
62			TC	183.7	183.7	190.5	175.6	175.6	186.8	166.9	166.9	182.7	158.1	158.1	177.9	148.9	148.9	171.5	
			SHC	138.5	164.5	190.5	134.9	160.8	186.8	130.9	156.8	182.7	126.6	152.3	177.9	121.3	146.4	171.5	
67			TC	201.7	201.7	201.7	192.9	192.9	192.9	183.4	183.4	183.4	173.4	173.4	173.4	162.9	162.9	162.9	
			SHC	112.3	138.3	164.3	108.8	134.9	161.0	105.1	131.2	157.4	101.2	127.5	153.7	97.2	123.5	149.8	
72		TC	222.2	222.2	222.2	212.5	212.5	212.5	202.1	202.1	202.1	191.1	191.1	191.1	179.4	179.4	179.4		
		SHC	85.8	111.3	136.8	82.2	107.9	133.6	78.4	104.3	130.1	74.5	100.5	126.5	70.4	96.5	122.6		
76		TC	—	240.0	240.0	—	229.4	229.4	—	218.3	218.3	—	206.4	206.4	—	193.5	193.5		
		SHC	—	88.8	117.7	—	85.7	107.4	—	82.2	105.9	—	78.5	103.0	—	74.5	99.7		
6000 cfm		EA (wb)	58	TC	183.9	183.9	207.9	177.3	177.3	200.4	170.0	170.0	192.2	162.4	162.4	183.5	154.2	154.2	174.3
				SHC	160.0	183.9	207.9	154.2	177.3	200.4	147.9	170.0	192.2	141.3	162.4	183.5	134.2	154.2	174.3
	62		TC	188.4	188.4	206.1	180.1	180.1	201.6	171.5	171.5	196.0	163.6	163.6	187.6	156.3	156.3	173.7	
			SHC	147.8	176.9	206.1	143.7	172.7	201.6	139.0	167.5	196.0	132.9	160.3	187.6	124.0	148.9	173.7	
	67		TC	206.5	206.5	206.5	197.3	197.3	197.3	187.4	187.4	187.4	177.0	177.0	177.0	166.0	166.0	166.0	
			SHC	118.3	147.8	177.3	114.8	144.4	173.9	111.1	140.7	170.4	107.2	136.8	166.5	103.1	132.7	162.4	
	72	TC	227.1	227.1	227.1	217.0	217.0	217.0	206.2	206.2	206.2	194.7	194.7	194.7	182.5	182.5	182.5		
		SHC	88.0	117.1	146.2	84.4	113.7	142.9	80.6	110.0	139.4	76.6	106.1	135.6	72.4	102.0	131.6		
	76	TC	—	244.9	244.9	—	234.0	234.0	—	222.3	222.3	—	210.0	210.0	—	197.0	197.0		
		SHC	—	91.9	118.1	—	88.5	115.7	—	84.9	112.8	—	81.1	109.6	—	77.1	106.0		
	6750 cfm	EA (wb)	58	TC	190.8	190.8	215.5	183.8	183.8	207.6	176.2	176.2	199.1	168.1	168.1	189.9	159.4	159.4	180.1
				SHC	166.0	190.8	215.5	159.9	183.8	207.6	153.3	176.2	199.1	146.2	168.1	189.9	138.7	159.4	180.1
62			TC	192.8	192.8	218.6	184.7	184.7	213.0	178.8	178.8	196.7	168.7	168.7	195.3	159.6	159.6	187.1	
			SHC	155.4	187.0	218.6	150.8	181.9	213.0	140.9	168.8	196.7	138.1	166.7	195.3	132.0	159.6	187.1	
67			TC	210.4	210.4	210.4	200.8	200.8	200.8	190.7	190.7	190.7	183.1	183.1	183.1	168.5	168.5	174.5	
			SHC	124.2	157.0	189.9	120.6	153.5	186.5	116.8	149.8	182.8	111.4	142.1	172.8	108.6	141.6	174.5	
72		TC	231.1	231.1	231.1	220.6	220.6	220.6	209.4	209.4	209.4	197.5	197.5	197.5	185.0	185.0	185.0		
		SHC	90.0	122.6	155.2	86.4	119.1	151.8	82.5	115.3	148.1	78.5	111.4	144.3	74.3	107.2	140.2		
76		TC	—	249.0	249.0	—	237.6	237.6	—	225.6	225.6	—	213.0	213.0	—	199.2	199.2		
		SHC	—	94.4	125.1	—	90.9	122.2	—	87.3	119.0	—	83.5	115.6	—	79.3	111.7		
7500 cfm		EA (wb)	58	TC	196.7	196.7	222.2	189.3	189.3	213.8	181.4	181.4	204.9	172.9	172.9	195.3	163.8	163.8	185.1
				SHC	171.2	196.7	222.2	164.7	189.3	213.8	157.9	181.4	204.9	150.5	172.9	195.3	142.6	163.8	185.1
	62		TC	197.9	197.9	226.5	191.3	191.3	214.8	181.6	181.6	212.9	173.1	173.1	202.9	164.0	164.0	192.3	
			SHC	160.7	193.6	226.5	153.1	183.9	214.8	150.2	181.6	212.9	143.2	173.1	202.9	135.7	164.0	192.3	
	67		TC	213.5	213.5	213.5	203.7	203.7	203.7	193.2	193.2	194.7	182.3	182.3	190.5	171.1	171.1	186.1	
			SHC	129.8	166.0	202.1	126.1	162.3	198.5	122.3	158.5	194.7	118.3	154.4	190.5	114.2	150.1	186.1	
	72	TC	234.3	234.3	234.3	223.5	223.5	223.5	211.9	211.9	211.9	199.8	199.8	199.8	187.0	187.0	187.0		
		SHC	91.8	127.8	163.7	88.2	124.2	160.3	84.3	120.4	156.6	80.3	116.4	152.6	76.1	112.3	148.5		
	76	TC	—	252.2	252.2	—	240.6	240.6	—	228.4	228.4	—	215.3	215.3	—	201.4	201.4		
		SHC	—	96.7	131.2	—	93.1	128.0	—	89.5	124.8	—	85.5	121.2	—	81.4	117.2		

LEGEND

- db — dry bulb
- EA — Entering Air Temperature (°F)
- SHC — Sensible Heat Capacity (1000 Btuh) gross
- TC — Total Capacity (1000 Btuh) gross
- wb — wet bulb

38AUD16/40RUA16 Stage 2 Combination Ratings — 60 Hz

38AUD16/40RUA16			AMBIENT TEMPERATURE (°F)																
			85			95			105			115			125				
			EA (db)			EA (db)			EA (db)			EA (db)			EA (db)				
			75	80	85	75	80	85	75	80	85	75	80	85	75	80	85		
3750 cfm	EA (wb)	58	TC	137.5	137.5	150.1	131.2	131.2	145.3	124.6	124.6	139.8	118.3	118.3	132.3	110.9	110.9	125.5	
			SHC	116.0	133.0	150.1	111.9	128.6	145.3	107.3	123.5	139.8	101.7	117.0	132.3	96.3	110.9	125.5	
		62	TC	145.4	145.4	145.4	137.9	137.9	139.5	130.4	130.4	133.1	122.5	122.5	128.1	114.6	114.6	121.7	
			SHC	105.6	124.5	143.3	101.9	120.7	139.5	96.9	115.0	133.1	92.5	110.3	128.1	87.4	104.6	121.7	
		67	TC	161.3	161.3	161.3	153.1	153.1	153.1	144.3	144.3	144.3	135.0	135.0	135.0	125.1	125.1	125.1	
			SHC	87.4	106.2	124.9	84.1	102.9	121.8	80.5	99.5	118.4	76.9	95.9	114.9	73.1	92.1	111.1	
	72	TC	178.7	178.7	178.7	170.0	170.0	170.0	160.5	160.5	160.5	150.4	150.4	150.4	139.7	139.7	139.7		
		SHC	69.5	87.3	105.2	66.0	84.2	102.4	62.4	80.8	99.3	58.6	77.3	95.9	54.8	73.5	92.3		
	76	TC	—	193.5	193.5	—	184.5	184.5	—	174.4	174.4	—	163.8	163.8	—	152.3	152.3		
		SHC	—	72.3	90.0	—	68.9	87.6	—	65.5	84.6	—	61.8	81.1	—	58.3	77.7		
	4500 cfm	EA (wb)	58	TC	146.7	146.7	163.1	139.7	139.7	158.1	133.1	133.1	150.5	125.9	125.9	142.4	118.3	118.3	133.8
				SHC	125.7	144.4	163.1	121.4	139.7	158.1	115.6	133.1	150.5	109.3	125.9	142.4	102.8	118.3	133.8
62			TC	152.1	152.1	156.8	149.3	149.3	149.3	136.9	136.9	146.5	132.8	132.8	136.2	120.2	120.2	133.3	
			SHC	113.9	135.4	156.8	107.4	127.9	148.3	105.1	125.8	146.5	97.2	116.7	136.2	94.6	114.0	133.3	
67			TC	167.6	167.6	167.6	159.0	159.0	159.0	149.6	149.6	149.6	139.6	139.6	139.6	129.2	129.2	129.2	
			SHC	94.1	116.5	138.9	90.8	113.2	135.6	87.1	109.6	132.1	83.3	105.8	128.3	79.3	101.8	124.3	
72		TC	185.4	185.4	185.4	176.1	176.1	176.1	166.0	166.0	166.0	155.3	155.3	155.3	144.1	144.1	144.1		
		SHC	72.2	94.0	115.8	68.7	90.8	112.8	65.1	87.2	109.4	61.3	83.6	105.9	57.4	79.8	102.1		
76		TC	—	200.8	200.8	—	191.0	191.0	—	180.2	180.2	—	168.8	168.8	—	156.6	156.6		
		SHC	—	75.1	97.7	—	72.0	94.9	—	68.9	91.9	—	65.4	86.0	—	61.7	83.2		
5250 cfm		EA (wb)	58	TC	154.0	154.0	174.1	147.3	147.3	166.6	140.1	140.1	158.5	132.4	132.4	149.8	124.3	124.3	140.6
				SHC	133.8	154.0	174.1	128.0	147.3	166.6	121.8	140.1	158.5	115.1	132.4	149.8	108.0	124.3	140.6
	62		TC	157.9	157.9	170.3	150.4	150.4	164.5	142.3	142.3	157.8	133.6	133.6	151.5	124.8	124.8	144.5	
			SHC	122.1	146.2	170.3	117.4	140.9	164.5	112.1	134.9	157.8	107.1	129.3	151.5	101.8	123.2	144.5	
	67		TC	174.1	174.1	174.1	163.3	163.3	163.3	153.5	153.5	153.5	143.0	143.0	143.0	132.4	132.4	135.0	
			SHC	101.6	126.3	151.1	97.0	122.9	148.8	93.2	119.1	145.0	89.1	114.8	140.6	84.4	109.7	135.0	
	72	TC	190.2	190.2	190.2	180.6	180.6	180.6	170.1	170.1	170.1	158.9	158.9	158.9	147.2	147.2	147.2		
		SHC	74.6	100.0	125.5	71.2	96.7	122.3	67.5	93.2	118.9	63.7	89.5	115.2	59.7	85.5	111.3		
	76	TC	—	205.8	205.8	—	195.5	195.5	—	184.3	184.3	—	172.4	172.4	—	159.8	159.8		
		SHC	—	78.6	105.1	—	75.5	98.9	—	72.0	96.4	—	68.4	93.3	—	64.5	89.8		
	6000 cfm	EA (wb)	58	TC	160.7	160.7	181.7	153.7	153.7	173.8	146.1	146.1	165.2	137.9	137.9	156.0	129.3	129.3	146.2
				SHC	139.7	160.7	181.7	133.6	153.7	173.8	127.0	146.1	165.2	119.9	137.9	156.0	112.4	129.3	146.2
62			TC	163.1	163.1	181.3	155.2	155.2	175.9	146.8	146.8	168.6	138.2	138.2	161.6	130.1	130.1	149.5	
			SHC	128.9	155.1	181.3	124.5	150.2	175.9	119.0	143.8	168.6	113.8	137.7	161.6	105.8	127.7	149.5	
67			TC	176.0	176.0	176.0	166.6	166.6	166.6	156.4	156.4	156.7	145.9	145.9	151.1	136.0	136.0	142.7	
			SHC	106.3	135.5	164.7	102.7	131.9	161.1	98.6	127.6	156.7	94.0	122.5	151.1	88.1	115.4	142.7	
72		TC	194.0	194.0	194.0	184.1	184.1	184.1	173.2	173.2	173.2	161.7	161.7	161.7	149.6	149.6	149.6		
		SHC	76.8	105.7	134.6	73.4	102.4	131.4	69.7	98.8	127.9	65.9	95.0	124.1	61.8	91.0	120.1		
76		TC	—	209.6	209.6	—	198.9	198.9	—	187.4	187.4	—	175.2	175.2	—	162.2	162.2		
		SHC	—	81.5	108.7	—	78.3	106.0	—	74.8	103.0	—	71.1	99.6	—	67.1	95.8		
6750 cfm		EA (wb)	58	TC	166.4	166.4	188.1	159.1	159.1	179.8	151.1	151.1	170.8	142.5	142.5	161.1	133.6	133.6	151.0
				SHC	144.7	166.4	188.1	138.3	159.1	179.8	131.4	151.1	170.8	124.0	142.5	161.1	116.1	133.6	151.0
	62		TC	167.4	167.4	191.8	159.6	159.6	184.9	152.2	152.2	174.4	143.0	143.0	165.9	133.7	133.7	156.9	
			SHC	135.5	163.6	191.8	130.5	157.7	184.9	123.5	149.0	174.4	117.2	141.5	165.9	110.5	133.7	156.9	
	67		TC	179.0	179.0	179.0	169.3	169.3	172.4	159.1	159.1	166.8	149.4	149.4	157.7	138.5	138.5	151.6	
			SHC	111.8	144.2	176.6	108.0	140.2	172.4	103.4	135.1	166.8	97.2	127.5	157.7	92.3	121.9	151.6	
	72	TC	197.0	197.0	197.0	186.8	186.8	186.8	175.7	175.7	175.7	163.9	163.9	163.9	151.5	151.5	151.5		
		SHC	78.9	111.2	143.4	75.5	107.8	140.1	71.8	104.1	136.5	67.9	100.2	132.6	63.8	96.2	128.5		
	76	TC	—	212.7	212.7	—	201.8	201.8	—	190.0	190.0	—	177.5	177.5	—	164.1	164.1		
		SHC	—	84.1	115.2	—	80.9	112.3	—	77.3	109.0	—	73.5	105.4	—	69.5	101.5		

LEGEND

- db — dry bulb
- EA — Entering Air Temperature (°F)
- SHC — Sensible Heat Capacity (1000 Btuh) gross
- TC — Total Capacity (1000 Btuh) gross
- wb — wet bulb

38AUD16/40RUA16 Stage 1 Combination Ratings — 60 Hz

38AUD16/40RUA16				AMBIENT TEMPERATURE (°F)															
				85			95			105			115			125			
				EA (db)			EA (db)			EA (db)			EA (db)			EA (db)			
				75	80	85	75	80	85	75	80	85	75	80	85	75	80	85	
3750 cfm	EA (wb)	58	TC	51.8	51.8	64.3	49.3	49.3	59.3	45.9	45.9	57.6	42.7	42.7	53.6	39.4	39.4	49.4	
			SHC	38.4	51.3	64.3	36.0	47.6	59.3	34.2	45.9	57.6	31.8	42.7	53.6	29.3	39.4	49.4	
		62	TC	54.9	54.9	61.8	51.4	51.4	60.7	47.3	47.3	58.0	43.2	43.2	55.2	40.0	40.0	50.2	
			SHC	33.5	47.6	61.8	32.0	46.3	60.7	29.9	43.9	58.0	27.9	41.5	55.2	25.6	37.9	50.2	
		67	TC	60.8	60.8	60.8	56.9	56.9	56.9	52.5	52.5	52.5	48.0	48.0	49.9	43.2	43.2	48.0	
			SHC	26.6	40.5	54.4	24.9	39.1	53.2	23.1	37.4	51.7	21.3	35.6	49.9	19.4	33.7	48.0	
	72	TC	67.6	67.6	67.6	63.3	63.3	63.3	58.6	58.6	58.6	53.6	53.6	53.6	48.4	48.4	48.4		
		SHC	20.3	33.2	46.1	18.3	31.8	45.2	16.3	30.2	44.1	14.4	28.5	42.7	12.4	26.8	41.2		
	76	TC	—	73.3	73.3	—	68.8	68.8	—	63.8	63.8	—	58.6	58.6	—	53.1	53.1		
		SHC	—	26.6	47.2	—	25.3	45.9	—	24.1	44.7	—	22.6	35.0	—	21.0	34.6		
	4500 cfm	EA (wb)	58	TC	54.9	54.9	68.9	51.9	51.9	65.2	48.6	48.6	61.0	45.2	45.2	56.7	41.5	41.5	52.1
				SHC	40.9	54.9	68.9	38.7	51.9	65.2	36.2	48.6	61.0	33.6	45.2	56.7	30.9	41.5	52.1
62			TC	56.9	56.9	67.7	53.1	53.1	66.1	49.1	49.1	63.1	45.3	45.3	59.6	41.5	41.5	55.6	
			SHC	35.5	51.6	67.7	33.8	50.0	66.1	31.8	47.4	63.1	29.7	44.6	59.6	27.5	41.5	55.6	
67			TC	62.9	62.9	62.9	58.7	58.7	58.9	54.2	54.2	57.2	49.4	49.4	55.5	44.4	44.4	53.4	
			SHC	27.6	44.0	60.5	25.9	42.4	58.9	24.1	40.7	57.2	22.2	38.9	55.5	20.3	36.9	53.4	
72		TC	69.6	69.6	69.6	65.1	65.1	65.1	60.2	60.2	60.2	55.0	55.0	55.0	49.6	49.6	49.6		
		SHC	19.6	35.4	51.2	17.7	33.9	50.1	15.8	32.3	48.8	13.9	30.6	47.3	12.0	28.8	45.6		
76		TC	—	75.2	75.2	—	70.8	70.8	—	65.6	65.6	—	60.1	60.1	—	54.3	54.3		
		SHC	—	28.0	52.7	—	26.7	51.5	—	25.3	40.1	—	23.7	39.6	—	22.0	38.6		
5250 cfm		EA (wb)	58	TC	57.6	57.6	72.2	54.4	54.4	68.2	50.9	50.9	63.8	47.2	47.2	59.2	43.3	43.3	54.4
				SHC	42.9	57.6	72.2	40.5	54.4	68.2	37.9	50.9	63.8	35.1	47.2	59.2	32.3	43.3	54.4
	62		TC	58.6	58.6	73.7	54.9	54.9	70.1	51.0	51.0	68.1	47.3	47.3	63.1	43.4	43.4	58.1	
			SHC	37.5	55.6	73.7	35.4	52.8	70.1	33.6	50.9	68.1	31.2	47.1	63.1	28.7	43.4	58.1	
	67		TC	64.4	64.4	65.8	60.1	60.1	64.1	55.4	55.4	62.5	50.5	50.5	60.5	45.6	45.6	58.4	
			SHC	28.4	47.1	65.8	26.7	45.4	64.1	24.9	43.7	62.5	23.0	41.7	60.5	21.2	39.8	58.4	
	72	TC	70.9	70.9	70.9	66.4	66.4	66.4	61.4	61.4	61.4	56.1	56.1	56.1	50.6	50.6	50.6		
		SHC	18.9	37.2	55.6	17.2	35.8	54.3	15.4	34.1	52.8	13.5	32.4	51.3	11.6	30.6	49.5		
	76	TC	—	76.8	76.8	—	72.1	72.1	—	66.8	66.8	—	61.0	61.0	—	55.1	55.1		
		SHC	—	29.0	44.1	—	27.7	44.5	—	26.2	44.2	—	24.5	43.2	—	22.8	41.9		
	6000 cfm	EA (wb)	58	TC	59.8	59.8	75.0	56.5	56.5	70.8	52.7	52.7	66.2	48.9	48.9	61.3	44.8	44.8	56.2
				SHC	44.5	59.8	75.0	42.1	56.5	70.8	39.3	52.7	66.2	36.4	48.9	61.3	33.4	44.8	56.2
62			TC	60.3	60.3	78.0	56.7	56.7	74.7	53.3	53.3	67.5	48.9	48.9	65.6	44.8	44.8	60.0	
			SHC	39.1	58.6	78.0	37.2	56.0	74.7	34.2	50.9	67.5	32.3	48.9	65.6	29.6	44.8	60.0	
67			TC	65.7	65.7	70.8	61.3	61.3	69.0	57.9	57.9	62.9	51.4	51.4	65.1	46.1	46.1	62.7	
			SHC	29.1	50.0	70.8	27.5	48.3	69.0	25.4	44.2	62.9	23.8	44.4	65.1	21.9	42.3	62.7	
72		TC	72.1	72.1	72.1	67.5	67.5	67.5	62.4	62.4	62.4	57.0	57.0	57.0	51.4	51.4	53.2		
		SHC	18.3	38.9	59.5	16.7	37.4	58.2	14.9	35.8	56.7	13.0	34.0	55.0	11.2	32.2	53.2		
76		TC	—	78.1	78.1	—	73.2	73.2	—	67.8	67.8	—	61.8	61.8	—	55.8	55.8		
		SHC	—	29.9	48.7	—	28.5	48.4	—	27.0	47.5	—	25.2	46.4	—	23.5	44.9		
6750 cfm		EA (wb)	58	TC	61.6	61.6	77.4	58.3	58.3	73.1	54.3	54.3	68.2	50.3	50.3	63.1	46.0	46.0	57.8
				SHC	45.9	61.6	77.4	43.4	58.3	73.1	40.5	54.3	68.2	37.5	50.3	63.1	34.3	46.0	57.8
	62		TC	62.0	62.0	81.4	58.5	58.5	77.1	55.0	55.0	69.0	50.5	50.5	67.6	46.0	46.0	61.6	
			SHC	40.5	61.0	81.4	38.3	57.7	77.1	35.1	52.0	69.0	33.3	50.5	67.6	30.4	46.0	61.6	
	67		TC	66.7	66.7	75.5	62.2	62.2	73.8	57.2	57.2	71.9	52.1	52.1	69.6	46.8	46.8	66.4	
			SHC	29.8	52.7	75.5	28.2	51.0	73.8	26.4	49.1	71.9	24.5	47.1	69.6	22.6	44.5	66.4	
	72	TC	73.1	73.1	73.1	68.4	68.4	68.4	63.3	63.3	63.3	57.7	57.7	58.6	51.9	51.9	56.6		
		SHC	17.8	40.5	63.3	16.1	39.0	61.8	14.4	37.3	60.3	12.5	35.5	58.6	10.7	33.7	56.6		
	76	TC	—	79.0	79.0	—	74.1	74.1	—	68.4	68.4	—	62.5	62.5	—	56.4	56.4		
		SHC	—	30.6	52.3	—	29.2	51.6	—	27.6	50.6	—	25.8	49.3	—	24.1	47.7		

LEGEND

- db — dry bulb
- EA — Entering Air Temperature (°F)
- SHC — Sensible Heat Capacity (1000 Btuh) gross
- TC — Total Capacity (1000 Btuh) gross
- wb — wet bulb

38AUZ25/40RUA25 Stage 2 Combination Ratings — 60 Hz

38AUZ25/40RUA25				AMBIENT TEMPERATURE (°F)															
				85			95			105			115			125			
				EA (db)			EA (db)			EA (db)			EA (db)			EA (db)			
				75	80	85	75	80	85	75	80	85	75	80	85	75	80	85	
6000 cfm	EA (wb)	58	TC	215.6	215.6	238.3	208.4	208.4	231.1	199.5	199.5	225.3	190.8	190.8	215.4	181.4	181.4	204.8	
			SHC	184.8	211.5	238.3	179.0	205.0	231.1	173.7	199.5	225.3	166.1	190.8	215.4	158.0	181.4	204.8	
		62	TC	230.5	230.5	230.5	217.7	217.7	220.6	207.1	207.1	219.0	199.0	199.0	206.3	185.1	185.1	205.3	
			SHC	162.2	189.3	216.4	161.9	191.2	220.6	159.0	189.0	219.0	150.0	178.1	206.3	146.9	176.1	205.3	
		67	TC	249.0	249.0	249.0	238.9	238.9	238.9	227.9	227.9	227.9	215.9	215.9	215.9	202.8	202.8	202.8	
			SHC	136.2	165.3	194.4	131.9	161.1	190.3	127.4	156.6	185.9	122.5	151.8	181.2	117.3	146.6	176.0	
	72	TC	273.3	273.3	273.3	261.9	261.9	261.9	249.7	249.7	249.7	236.5	236.5	236.5	222.4	222.4	222.4		
		SHC	106.3	134.3	162.3	101.9	130.2	158.5	97.1	125.7	154.3	92.2	121.0	149.7	86.9	115.9	144.8		
	76	TC	—	294.6	294.6	—	282.6	282.6	—	268.8	268.8	—	254.5	254.5	—	238.4	238.4		
		SHC	—	108.7	141.7	—	104.1	137.1	—	100.6	133.6	—	96.1	122.3	—	91.0	118.8		
	7000 cfm	EA (wb)	58	TC	225.8	225.8	255.0	218.2	218.2	246.3	209.6	209.6	236.6	200.4	200.4	226.2	190.3	190.3	214.8
				SHC	196.7	225.8	255.0	190.1	218.2	246.3	182.6	209.6	236.6	174.6	200.4	226.2	165.8	190.3	214.8
62			TC	234.3	234.3	248.6	224.3	224.3	241.4	214.0	214.0	236.2	202.7	202.7	230.0	192.7	192.7	216.7	
			SHC	182.1	215.4	248.6	174.2	207.8	241.4	169.3	202.7	236.2	163.8	196.9	230.0	154.6	185.7	216.7	
67			TC	256.4	256.4	256.4	245.6	245.6	245.6	234.0	234.0	234.0	221.4	221.4	221.4	207.6	207.6	207.6	
			SHC	144.0	177.5	211.1	139.6	173.2	206.9	135.0	168.7	202.3	130.0	163.7	197.4	124.7	158.4	192.1	
72		TC	280.6	280.6	280.6	268.6	268.6	268.6	255.8	255.8	255.8	242.1	242.1	242.1	227.3	227.3	227.3		
		SHC	108.9	141.6	174.3	104.4	137.3	170.2	99.7	132.7	165.8	94.7	127.9	161.1	89.4	122.7	156.1		
76		TC	—	301.8	301.8	—	288.7	288.7	—	274.5	274.5	—	259.4	259.4	—	243.0	243.0		
		SHC	—	112.4	150.9	—	108.4	137.5	—	103.9	134.9	—	99.2	131.1	—	94.0	126.6		
8000 cfm		EA (wb)	58	TC	235.6	235.6	265.9	227.1	227.1	256.4	218.1	218.1	246.2	208.3	208.3	235.1	197.5	197.5	222.9
				SHC	205.3	235.6	265.9	197.9	227.1	256.4	190.0	218.1	246.2	181.5	208.3	235.1	172.1	197.5	222.9
	62		TC	240.0	240.0	265.1	229.9	229.9	259.4	220.1	220.1	251.3	210.6	210.6	239.4	202.6	202.6	217.3	
			SHC	190.1	227.6	265.1	185.0	222.2	259.4	178.8	215.0	251.3	170.4	204.9	239.4	157.0	187.1	217.3	
	67		TC	262.0	262.0	262.0	250.8	250.8	250.8	238.7	238.7	238.7	225.5	225.5	225.5	211.5	211.5	211.5	
			SHC	151.3	189.1	227.0	146.8	184.7	222.6	142.2	180.0	217.9	137.2	175.1	213.0	131.7	169.5	207.3	
	72	TC	286.2	286.2	286.2	273.8	273.8	273.8	260.6	260.6	260.6	246.5	246.5	246.5	230.8	230.8	230.8		
		SHC	111.1	148.2	185.3	106.7	143.9	181.1	101.9	139.3	176.6	96.9	134.4	171.8	91.5	129.0	166.5		
	76	TC	—	307.2	307.2	—	293.6	293.6	—	279.2	279.2	—	263.3	263.3	—	246.4	246.4		
		SHC	—	115.5	149.6	—	111.2	146.4	—	106.7	142.7	—	101.7	138.3	—	96.4	133.3		
	9000 cfm	EA (wb)	58	TC	243.4	243.4	274.7	234.7	234.7	264.8	225.2	225.2	254.1	215.1	215.1	242.7	203.5	203.5	229.6
				SHC	212.2	243.4	274.7	204.5	234.7	264.8	196.3	225.2	254.1	187.4	215.1	242.7	177.4	203.5	229.6
62			TC	245.3	245.3	280.3	235.0	235.0	275.3	230.2	230.2	250.2	217.6	217.6	243.1	203.7	203.7	238.6	
			SHC	199.4	239.9	280.3	194.7	235.0	275.3	180.2	215.2	250.2	173.9	208.5	243.1	168.8	203.7	238.6	
67			TC	266.6	266.6	266.6	254.9	254.9	254.9	242.5	242.5	242.5	229.1	229.1	229.1	214.3	214.3	222.0	
			SHC	158.2	200.2	242.1	153.7	195.7	237.7	149.0	190.9	232.9	143.9	185.7	227.6	138.4	180.2	222.0	
72		TC	290.8	290.8	290.8	277.8	277.8	277.8	264.2	264.2	264.2	249.6	249.6	249.6	233.7	233.7	233.7		
		SHC	113.1	154.4	195.7	108.5	150.0	191.4	103.8	145.3	186.8	98.8	140.3	181.9	93.4	135.0	176.5		
76		TC	—	311.5	311.5	—	297.4	297.4	—	282.4	282.4	—	266.4	266.4	—	249.0	249.0		
		SHC	—	117.8	157.2	—	113.5	153.5	—	108.8	149.3	—	103.8	144.6	—	98.4	139.4		
10,000 cfm		EA (wb)	58	TC	250.4	250.4	282.5	241.3	241.3	272.2	231.3	231.3	260.9	220.5	220.5	248.8	208.8	208.8	235.6
				SHC	218.2	250.4	282.5	210.3	241.3	272.2	201.6	231.3	260.9	192.2	220.5	248.8	182.0	208.8	235.6
	62		TC	250.6	250.6	293.5	245.3	245.3	275.2	234.0	234.0	262.7	220.9	220.9	258.8	208.8	208.8	244.6	
			SHC	207.7	250.6	293.5	196.6	235.9	275.2	187.7	225.2	262.7	183.1	220.9	258.8	173.0	208.8	244.6	
	67		TC	270.4	270.4	270.4	258.4	258.4	258.4	245.6	245.6	247.3	231.6	231.6	241.9	216.7	216.7	235.8	
			SHC	164.9	210.8	256.8	160.3	206.3	252.2	155.6	201.4	247.3	150.4	196.2	241.9	144.9	190.3	235.8	
	72	TC	294.4	294.4	294.4	281.3	281.3	281.3	267.4	267.4	267.4	252.3	252.3	252.3	235.9	235.9	235.9		
		SHC	114.8	160.2	205.6	110.3	155.7	201.2	105.6	151.0	196.5	102.9	148.3	193.7	95.1	140.5	186.0		
	76	TC	—	314.9	314.9	—	300.5	300.5	—	271.5	271.5	—	269.1	269.1	—	251.3	251.3		
		SHC	—	119.7	163.6	—	115.3	159.6	—	106.2	150.8	—	105.5	150.4	—	100.0	145.0		

LEGEND

- db — dry bulb
- EA — Entering Air Temperature (°F)
- SHC — Sensible Heat Capacity (1000 Btuh) gross
- TC — Total Capacity (1000 Btuh) gross
- wb — wet bulb

38AUZ25/40RUA25 Stage 1 Combination Ratings — 60 Hz

38AUZ25/40RUA25				AMBIENT TEMPERATURE (°F)															
				85			95			105			115			125			
				EA (db)			EA (db)			EA (db)			EA (db)			EA (db)			
				75	80	85	75	80	85	75	80	85	75	80	85	75	80	85	
5000 cfm	EA (wb)	58	TC	133.2	133.2	150.2	128.4	128.4	144.8	123.3	123.3	139.0	117.7	117.7	132.7	111.6	111.6	125.8	
			SHC	116.3	133.2	150.2	112.1	128.4	144.8	107.6	123.3	139.0	102.7	117.7	132.7	97.4	111.6	125.8	
		62	TC	134.4	134.4	153.7	128.6	128.6	150.3	123.4	123.4	144.4	117.8	117.8	137.8	111.7	111.7	130.7	
			SHC	109.6	131.7	153.7	106.7	128.5	150.3	102.4	123.4	144.4	97.8	117.8	137.8	92.7	111.7	130.7	
		67	TC	144.3	144.3	144.3	137.9	137.9	137.9	131.1	131.1	132.6	123.9	123.9	129.8	116.0	116.0	126.8	
			SHC	89.2	113.4	137.6	86.7	110.9	135.1	84.2	108.4	132.6	81.4	105.6	129.8	78.5	102.6	126.8	
	72	TC	158.4	158.4	158.4	151.4	151.4	151.4	143.9	143.9	143.9	136.0	136.0	136.0	—	—	—		
		SHC	64.5	88.3	112.0	62.0	85.9	109.7	59.4	83.4	107.3	56.7	80.7	104.7	—	—	—		
	76	TC	—	—	—	—	—	—	—	—	—	—	—	—	—	—	—		
		SHC	—	—	—	—	—	—	—	—	—	—	—	—	—	—	—		
	6000 cfm	EA (wb)	58	TC	140.1	140.1	157.9	134.8	134.8	152.0	129.2	129.2	145.7	123.2	123.2	138.9	116.6	116.6	131.4
				SHC	122.2	140.1	157.9	117.6	134.8	152.0	112.8	129.2	145.7	107.5	123.2	138.9	101.7	116.6	131.4
62			TC	140.1	140.1	164.0	134.9	134.9	157.8	129.3	129.3	151.3	123.3	123.3	144.3	116.7	116.7	136.5	
			SHC	116.3	140.1	164.0	112.0	134.9	157.8	107.3	129.3	151.3	102.4	123.3	144.3	96.8	116.7	136.5	
67			TC	147.6	147.6	153.3	140.9	140.9	150.6	133.8	133.8	147.8	126.3	126.3	144.6	118.3	118.3	140.8	
			SHC	96.3	124.8	153.3	93.8	122.2	150.6	91.1	119.5	147.8	88.2	116.4	144.6	84.9	112.9	140.8	
72		TC	161.8	161.8	161.8	154.4	154.4	154.4	146.7	146.7	146.7	—	—	—	—	—	—		
		SHC	67.0	95.1	123.1	64.5	92.6	120.8	61.9	90.1	118.4	—	—	—	—	—	—		
76		TC	—	—	—	—	—	—	—	—	—	—	—	—	—	—	—		
		SHC	—	—	—	—	—	—	—	—	—	—	—	—	—	—	—		
7000 cfm		EA (wb)	58	TC	145.5	145.5	164.0	139.9	139.9	157.7	133.9	133.9	151.0	127.5	127.5	143.7	120.5	120.5	135.8
				SHC	127.0	145.5	164.0	122.1	139.9	157.7	116.9	133.9	151.0	111.3	127.5	143.7	105.1	120.5	135.8
	62		TC	145.6	145.6	170.3	140.0	140.0	163.8	134.0	134.0	156.8	127.6	127.6	149.2	120.5	120.5	141.0	
			SHC	120.8	145.6	170.3	116.2	140.0	163.8	111.3	134.0	156.8	105.9	127.6	149.2	100.1	120.5	141.0	
	67		TC	149.9	149.9	167.8	143.1	143.1	164.7	136.0	136.0	161.3	128.5	128.5	156.9	121.7	121.7	146.4	
			SHC	103.0	135.4	167.8	100.3	132.5	164.7	97.3	129.3	161.3	93.9	125.4	156.9	88.0	117.2	146.4	
	72	TC	164.3	164.3	164.3	—	—	—	—	—	—	—	—	—	—	—	—		
		SHC	69.2	101.5	133.7	—	—	—	—	—	—	—	—	—	—	—	—		
	76	TC	—	—	—	—	—	—	—	—	—	—	—	—	—	—	—		
		SHC	—	—	—	—	—	—	—	—	—	—	—	—	—	—	—		
	8000 cfm	EA (wb)	58	TC	149.8	149.8	168.9	143.9	143.9	162.2	137.6	137.6	155.2	130.9	130.9	147.6	123.5	123.5	139.2
				SHC	130.7	149.8	168.9	125.6	143.9	162.2	120.1	137.6	155.2	114.3	130.9	147.6	107.8	123.5	139.2
62			TC	149.9	149.9	175.4	144.0	144.0	168.4	137.7	137.7	161.1	131.1	131.1	153.3	123.5	123.5	144.5	
			SHC	124.4	149.9	175.4	119.5	144.0	168.4	114.3	137.7	161.1	108.8	131.1	153.3	102.5	123.5	144.5	
67			TC	152.1	152.1	180.6	145.3	145.3	176.4	137.8	137.8	172.9	132.9	132.9	157.1	124.2	124.2	152.1	
			SHC	109.0	144.8	180.6	105.8	141.1	176.4	102.8	137.8	172.9	94.9	126.0	157.1	91.0	121.5	152.1	
72		TC	—	—	—	—	—	—	—	—	—	—	—	—	—	—	—		
		SHC	—	—	—	—	—	—	—	—	—	—	—	—	—	—	—		
76		TC	—	—	—	—	—	—	—	—	—	—	—	—	—	—	—		
		SHC	—	—	—	—	—	—	—	—	—	—	—	—	—	—	—		
9000 cfm		EA (wb)	58	TC	153.3	153.3	172.8	147.2	147.2	166.0	140.7	140.7	158.6	133.6	133.6	150.6	—	—	—
				SHC	133.8	153.3	172.8	128.5	147.2	166.0	122.8	140.7	158.6	116.6	133.6	150.6	—	—	—
	62		TC	153.5	153.5	179.5	147.3	147.3	172.3	140.8	140.8	164.8	133.7	133.7	156.4	—	—	—	
			SHC	127.4	153.5	179.5	122.3	147.3	172.3	116.9	140.8	164.8	111.0	133.7	156.4	—	—	—	
	67		TC	154.2	154.2	190.2	147.7	147.7	183.1	141.6	141.6	172.8	133.8	133.8	167.8	—	—	—	
			SHC	113.6	151.9	190.2	109.2	146.2	183.1	103.4	138.1	172.8	99.8	133.8	167.8	—	—	—	
	72	TC	—	—	—	—	—	—	—	—	—	—	—	—	—	—	—		
		SHC	—	—	—	—	—	—	—	—	—	—	—	—	—	—	—		
	76	TC	—	—	—	—	—	—	—	—	—	—	—	—	—	—	—		
		SHC	—	—	—	—	—	—	—	—	—	—	—	—	—	—	—		

LEGEND

- db — dry bulb
- EA — Entering Air Temperature (°F)
- SHC — Sensible Heat Capacity (1000 Btuh) gross
- TC — Total Capacity (1000 Btuh) gross
- wb — wet bulb

38AUD25/40RUA25 Stage 3 Combination Ratings — 60 Hz

38AUD25/40RUA25			AMBIENT TEMPERATURE (°F)																
			85			95			105			115			125				
			EA (db)			EA (db)			EA (db)			EA (db)			EA (db)				
			75	80	85	75	80	85	75	80	85	75	80	85	75	80	85		
6000 cfm	EA (wb)	58	TC	218.9	218.9	245.1	210.7	210.7	237.4	201.8	201.8	228.0	192.3	192.3	217.3	182.1	182.1	205.8	
			SHC	189.2	217.2	245.1	182.9	210.2	237.4	175.5	201.8	228.0	167.3	192.3	217.3	158.5	182.1	205.8	
		62	TC	234.0	234.0	234.0	220.9	220.9	225.0	209.5	209.5	219.9	197.6	197.6	214.4	184.9	184.9	206.9	
			SHC	176.0	195.0	214.0	164.6	194.8	225.0	159.5	189.7	219.9	154.1	184.2	214.4	147.5	177.2	206.9	
		67	TC	253.5	253.5	253.5	242.0	242.0	242.0	229.9	229.9	229.9	216.5	216.5	216.5	202.4	202.4	202.4	
			SHC	138.1	168.0	198.0	133.4	163.4	193.4	128.5	158.6	188.8	123.2	153.4	183.6	117.7	148.0	178.2	
	72	TC	278.0	278.0	278.0	265.4	265.4	265.4	252.2	252.2	252.2	237.5	237.5	237.5	222.0	222.0	222.0		
		SHC	107.1	136.0	164.9	102.2	131.4	160.6	97.2	126.7	156.2	91.8	121.5	151.2	86.2	116.1	146.0		
	76	TC	—	298.9	298.9	—	285.7	285.7	—	271.5	271.5	—	255.7	255.7	—	238.6	238.6		
		SHC	—	108.3	141.3	—	104.4	137.4	—	100.3	129.6	—	95.5	122.2	—	90.2	118.5		
	7000 cfm	EA (wb)	58	TC	230.0	230.0	259.8	221.5	221.5	250.3	212.1	212.1	239.6	201.7	201.7	227.9	190.8	190.8	215.6
				SHC	200.1	230.0	259.8	192.7	221.5	250.3	184.5	212.1	239.6	175.6	201.7	227.9	166.0	190.8	215.6
62			TC	237.9	237.9	251.5	227.4	227.4	246.6	215.6	215.6	240.6	203.6	203.6	232.1	191.7	191.7	221.9	
			SHC	182.0	216.7	251.5	177.3	211.9	246.6	171.7	206.2	240.6	164.8	198.4	232.1	157.0	189.4	221.9	
67			TC	260.6	260.6	260.6	248.8	248.8	248.8	235.4	235.4	235.4	221.5	221.5	221.5	206.8	206.8	206.8	
			SHC	146.0	180.6	215.2	141.3	176.0	210.7	136.1	170.9	205.6	130.8	165.6	200.4	125.3	160.2	195.0	
72		TC	284.8	284.8	284.8	272.0	272.0	272.0	257.7	257.7	257.7	242.9	242.9	242.9	226.5	226.5	226.5		
		SHC	109.4	143.2	177	104.7	138.8	172.8	99.6	133.8	168.1	94.3	128.8	163.2	88.7	123.2	157.8		
76		TC	—	306.9	306.9	—	292.4	292.4	—	277.0	277.0	—	260.3	260.3	—	243.0	243.0		
		SHC	—	112.8	146.3	—	108.4	138.4	—	103.7	135.4	—	98.5	131.3	—	93.2	126.7		
8,000 cfm		EA (wb)	58	TC	239.3	239.3	270.4	230.3	230.3	260.2	220.5	220.5	249.1	209.6	209.6	236.8	197.9	197.9	223.5
				SHC	208.3	239.3	270.4	200.4	230.3	260.2	191.8	220.5	249.1	182.4	209.6	236.8	172.2	197.9	223.5
	62		TC	243.6	243.6	271.1	232.9	232.9	265.0	221.6	221.6	256.4	211.3	211.3	241.0	199.0	199.0	229.2	
			SHC	193.6	232.4	271.1	188.3	226.6	265.0	181.4	218.9	256.4	171.2	206.1	241.0	162.3	195.7	229.2	
	67		TC	265.7	265.7	265.7	253.8	253.8	253.8	239.8	239.8	239.8	225.6	225.6	225.6	210.3	210.3	211.2	
			SHC	153.3	192.4	231.5	148.8	187.9	227.1	143.5	182.7	221.9	138.3	177.5	216.7	132.7	171.9	211.2	
	72	TC	290.5	290.5	290.5	277.1	277.1	277.1	262.7	262.7	262.7	247.2	247.2	247.2	229.9	229.9	229.9		
		SHC	111.7	150.1	188.6	106.9	145.6	184.3	101.9	140.7	179.5	96.7	135.6	174.6	90.9	129.9	169.0		
	76	TC	—	312.0	312.0	—	298.1	298.1	—	282.1	282.1	—	264.3	264.3	—	246.5	246.5		
		SHC	—	115.8	151.0	—	111.5	147.8	—	106.6	143.8	—	101.2	138.9	—	95.8	134.0		
	9,000 cfm	EA (wb)	58	TC	247.5	247.5	279.6	238.0	238.0	268.9	227.4	227.4	256.9	216.1	216.1	244.2	203.8	203.8	230.2
				SHC	215.4	247.5	279.6	207.1	238.0	268.9	197.9	227.4	256.9	188.1	216.1	244.2	177.3	203.8	230.2
62			TC	249.1	249.1	287.8	239.2	239.2	277.6	229.0	229.0	262.0	216.6	216.6	252.3	204.0	204.0	239.1	
			SHC	203.7	245.8	287.8	196.3	237.0	277.6	185.9	224.0	262.0	178.3	215.3	252.3	168.8	204.0	239.1	
67			TC	270.5	270.5	270.5	257.3	257.3	257.3	243.4	243.4	243.4	228.8	228.8	232.6	213.0	213.0	226.9	
			SHC	160.6	204.1	247.6	155.7	199.3	242.8	150.7	194.2	237.8	145.5	189.0	232.6	139.9	183.4	226.9	
72		TC	294.8	294.8	294.8	280.9	280.9	280.9	265.9	265.9	265.9	250.0	250.0	250.0	232.6	232.6	232.6		
		SHC	113.6	156.6	199.6	108.9	152.0	195.2	103.8	147.1	190.4	98.5	141.9	185.3	92.8	136.3	179.8		
76		TC	—	316.4	316.4	—	301.5	301.5	—	285.0	285.0	—	268	268.0	—	249.4	249.4		
		SHC	—	118.3	159.0	—	113.7	155.1	—	108.8	150.8	—	103.6	146.0	—	98.1	140.9		
10,000 cfm		EA (wb)	58	TC	254.6	254.6	287.7	244.9	244.9	276.6	233.7	233.7	264.0	221.7	221.7	250.5	208.8	208.8	235.9
				SHC	221.6	254.6	287.7	213.1	244.9	276.6	203.4	233.7	264.0	193.0	221.7	250.5	181.7	208.8	235.9
	62		TC	256.2	256.2	293.6	246.5	246.5	281.5	234.0	234.0	272.6	221.6	221.6	259.8	209.0	209.0	245.0	
			SHC	208.3	251.0	293.6	199.8	240.7	281.5	192.6	232.6	272.6	183.4	221.6	259.8	172.9	209.0	245.0	
	67		TC	273.5	273.5	273.5	260.6	260.6	260.6	246.3	246.3	253.2	230.9	230.9	247.7	215.1	215.1	241.6	
			SHC	167.3	215.1	262.8	162.7	210.5	258.2	157.7	205.4	253.2	152.3	200.0	247.7	146.7	194.1	241.6	
	72	TC	298.4	298.4	298.4	284.3	284.3	284.3	269.3	269.3	269.3	252.6	252.6	252.6	234.8	234.8	234.8		
		SHC	115.3	162.7	210.1	110.6	158.1	205.7	105.7	153.4	201.0	100.3	148.1	195.8	94.7	142.5	190.2		
	76	TC	—	320.7	320.7	—	305.4	305.4	—	288.6	288.6	—	270.6	270.6	—	251.7	251.7		
		SHC	—	120.5	166.1	—	115.9	162.0	—	110.9	157.4	—	105.5	152.4	—	100.0	147.1		

LEGEND

- db — dry bulb
- EA — Entering Air Temperature (°F)
- SHC — Sensible Heat Capacity (1000 Btuh) gross
- TC — Total Capacity (1000 Btuh) gross
- wb — wet bulb

38AUD25/40RUA25 Stage 2 Combination Ratings — 60 Hz

38AUD25/40RUA25			AMBIENT TEMPERATURE (°F)																
			85			95			105			115			125				
			EA (db)			EA (db)			EA (db)			EA (db)			EA (db)				
			75	80	85	75	80	85	75	80	85	75	80	85	75	80	85		
5000 cfm	EA (wb)	58	TC	176.7	176.7	194.4	168.3	168.3	187.0	159.4	159.4	179.0	150.5	150.5	168.4	140.2	140.2	159.1	
			SHC	149.0	171.7	194.4	142.9	165.0	187.0	136.7	157.8	179.0	128.7	148.6	168.4	121.2	140.2	159.1	
		62	TC	185.4	185.4	187.2	176.2	176.2	180.0	166.0	166.0	172.2	155.6	155.6	163.9	144.7	144.7	154.9	
			SHC	135.9	161.6	187.2	130.2	155.1	180.0	123.8	148.0	172.2	117.1	140.5	163.9	110.1	132.5	154.9	
		67	TC	206.6	206.6	206.6	195.5	195.5	195.5	183.5	183.5	183.5	170.7	170.7	170.7	156.8	156.8	156.8	
			SHC	111.5	137.0	162.5	107.1	132.7	158.3	102.3	128.0	153.7	97.5	123.2	148.9	92.3	118.0	143.8	
	72	TC	228.5	228.5	228.5	217.5	217.5	217.5	204.4	204.4	204.4	190.7	190.7	190.7	175.4	175.4	175.4		
		SHC	87.0	111.2	135.4	82.7	107.5	132.3	77.9	103.0	128.0	73.0	98.2	123.4	67.6	93.0	118.3		
	76	TC	—	247.7	247.7	—	235.9	235.9	—	222.1	222.1	—	207.3	207.3	—	190.6	190.6		
		SHC	—	91.2	117.1	—	87.3	113.5	—	82.7	109.1	—	77.6	104.1	—	72.5	99.0		
	6000 cfm	EA (wb)	58	TC	188.8	188.8	211.1	179.5	179.5	203.5	170.2	170.2	193.0	160.3	160.3	181.8	149.9	149.9	170.1
				SHC	161.7	186.4	211.1	155.4	179.4	203.5	147.3	170.2	193.0	138.8	160.3	181.8	129.8	149.9	170.1
62			TC	195.3	195.3	204.9	185.7	185.7	197.2	175.2	175.2	188.5	163.9	163.9	179.3	152.0	152.0	170.5	
			SHC	147.1	176.0	204.9	141.0	169.1	197.2	134.1	161.3	188.5	126.8	153.0	179.3	119.8	145.1	170.5	
67			TC	214.8	214.8	214.8	204.1	204.1	204.1	190.1	190.1	190.1	176.3	176.3	176.3	162.0	162.0	162.0	
			SHC	120.5	150.9	181.3	116.5	146.9	177.4	111.2	141.7	172.1	106.1	136.6	167.1	100.6	130.9	161.1	
72		TC	237.3	237.3	237.3	225.0	225.0	225.0	211.2	211.2	211.2	196.2	196.2	196.2	180.5	180.5	180.5		
		SHC	90.5	120.2	149.9	86.1	116.0	145.8	81.3	111.3	141.3	76.1	106.2	136.3	70.9	101.0	131.1		
76		TC	—	256.7	256.7	—	243.8	243.8	—	229.0	229.0	—	212.7	212.7	—	195.1	195.1		
		SHC	—	95.0	126.5	—	90.9	122.4	—	86.6	118.2	—	81.6	110.0	—	76.1	104.9		
7000 cfm		EA (wb)	58	TC	198.6	198.6	225.1	189.4	189.4	214.7	179.5	179.5	203.5	168.9	168.9	191.5	157.5	157.5	178.5
				SHC	172.1	198.6	225.1	164.1	189.4	214.7	155.5	179.5	203.5	146.4	168.9	191.5	136.4	157.5	178.5
	62		TC	203.5	203.5	220.5	193.6	193.6	212.4	182.1	182.1	204.2	170.2	170.2	194.1	159.4	159.4	182.3	
			SHC	156.9	188.7	220.5	150.5	181.5	212.4	143.9	174.0	204.2	136.2	165.1	194.1	128.2	155.3	182.3	
	67		TC	220.5	220.5	220.5	208.4	208.4	208.4	194.8	194.8	194.8	180.6	180.6	183.4	167.0	167.0	172.4	
			SHC	128.8	163.9	199.0	124.3	159.4	194.6	119.4	154.4	189.5	113.9	148.6	183.4	106.2	139.3	172.4	
	72	TC	243.3	243.3	243.3	230.8	230.8	230.8	216.1	216.1	216.1	200.5	200.5	200.5	184.5	184.5	184.5		
		SHC	93.5	128.0	162.5	89.2	123.8	158.4	84.2	118.9	153.5	79.0	113.8	148.5	73.8	108.5	143.2		
	76	TC	—	262.7	262.7	—	248.7	248.7	—	233.2	233.2	—	216.5	216.5	—	198.2	198.2		
		SHC	—	98.9	135.5	—	94.7	127.1	—	89.9	123	—	84.8	118.1	—	79.0	112.1		
	8000 cfm	EA (wb)	58	TC	207.1	207.1	234.6	197.6	197.6	223.9	187.2	187.2	212.1	175.8	175.8	199.2	163.7	163.7	185.4
				SHC	179.5	207.1	234.6	171.3	197.6	223.9	162.3	187.2	212.1	152.4	175.8	199.2	141.9	163.7	185.4
62			TC	209.9	209.9	235.7	199.5	199.5	227.0	188.2	188.2	218.0	176.6	176.6	205.1	164.5	164.5	190.7	
			SHC	166.4	201.1	235.7	159.6	193.3	227.0	152.8	185.4	218.0	143.9	174.5	205.1	133.9	162.3	190.7	
67			TC	224.8	224.8	224.8	212.4	212.4	212.4	198.8	198.8	205.1	186.0	186.0	193.7	171.6	171.6	183.3	
			SHC	136.8	176.4	216.0	132.1	171.7	211.2	126.8	165.9	205.1	119.1	156.4	193.7	111.6	147.5	183.3	
72		TC	247.9	247.9	247.9	234.6	234.6	234.6	219.9	219.9	219.9	203.9	203.9	203.9	187.0	187.0	187.0		
		SHC	96.1	135.2	174.3	91.7	130.8	170.0	86.8	126.0	165.2	81.6	120.8	160.0	76.2	115.3	154.4		
76		TC	—	266.7	266.7	—	253.2	253.2	—	237.1	237.1	—	218.9	218.9	—	199.9	199.9		
		SHC	—	102.0	139.1	—	97.9	135.4	—	92.9	130.7	—	87.3	124.9	—	81.1	118.1		
9000 cfm		EA (wb)	58	TC	214.4	214.4	242.8	204.5	204.5	231.6	193.5	193.5	219.1	181.6	181.6	205.6	169.0	169.0	191.4
				SHC	186.0	214.4	242.8	177.4	204.5	231.6	167.8	193.5	219.1	157.5	181.6	205.6	146.6	169.0	191.4
	62		TC	215.6	215.6	249.0	205.1	205.1	238.9	193.7	193.7	227.7	182.0	182.0	214.0	168.9	168.9	198.7	
			SHC	174.9	211.9	249.0	167.7	203.3	238.9	159.5	193.6	227.7	149.9	182.0	214.0	139.2	168.9	198.7	
	67		TC	228.7	228.7	231.8	215.8	215.8	225.4	203.3	203.3	214.7	189.4	189.4	204.7	174.8	174.8	192.9	
			SHC	144.1	188.0	231.8	138.9	182.1	225.4	131.5	173.1	214.7	124.3	164.5	204.7	116.2	154.5	192.9	
	72	TC	251.6	251.6	251.6	237.9	237.9	237.9	223.0	223.0	223.0	206.5	206.5	206.5	189.2	189.2	189.2		
		SHC	98.5	142.1	185.6	94.0	137.6	181.2	89.2	132.8	176.4	84.0	127.5	171.0	78.5	121.7	165.0		
	76	TC	—	270.4	270.4	—	256.2	256.2	—	239.1	239.1	—	221.4	221.4	—	202.0	202.0		
		SHC	—	104.6	146.5	—	100.3	142.4	—	95.0	136.9	—	89.5	131.3	—	83.1	123.9		

LEGEND

- db — dry bulb
- EA — Entering Air Temperature (°F)
- SHC — Sensible Heat Capacity (1000 Btuh) gross
- TC — Total Capacity (1000 Btuh) gross
- wb — wet bulb

38AUD25/40RUA25 Stage 1 Combination Ratings — 60 Hz

38AUD25/40RUA25			AMBIENT TEMPERATURE (°F)																
			85			95			105			115			125				
			EA (db)			EA (db)			EA (db)			EA (db)			EA (db)				
			75	80	85	75	80	85	75	80	85	75	80	85	75	80	85		
5000 cfm	EA (wb)	58	TC	78.6	78.6	99.9	78.6	78.6	99.9	78.6	78.6	99.8	78.6	78.6	99.8	78.6	78.6	99.9	
			SHC	57.4	78.6	99.9	57.4	78.6	99.9	57.4	78.6	99.8	57.4	78.6	99.8	57.4	78.6	99.9	
		62	TC	80.5	80.5	102.8	80.6	80.6	103.1	80.5	80.5	102.8	80.5	80.5	102.8	80.5	80.5	102.8	
			SHC	50.0	76.4	102.8	50.1	76.6	103.1	50.0	76.4	102.8	50.0	76.4	102.8	50.0	76.4	102.8	
		67	TC	90.0	90.0	90.3	90.0	90.0	90.4	90.0	90.0	90.3	90.0	90.0	90.4	90.0	90.0	90.4	
			SHC	37.6	64.0	90.3	37.6	64.0	90.4	37.6	64.0	90.3	37.6	64.0	90.4	37.6	64.0	90.4	
	72	TC	99.3	99.3	99.3	99.3	99.3	99.3	99.3	99.3	99.3	99.3	99.3	99.3	99.3	99.3	99.3		
		SHC	24.9	50.4	75.9	24.9	50.4	75.9	24.9	50.5	76.0	24.9	50.4	75.9	24.9	50.5	76.0		
	76	TC	—	108.4	108.4	—	108.5	108.5	—	108.2	108.2	—	108.4	108.4	—	108.3	108.3		
		SHC	—	40.5	64.9	—	40.5	64.9	—	41.5	68	—	40.5	64.9	—	40.5	64.9		
	6000 cfm	EA (wb)	58	TC	84.3	84.3	106.9	84.3	84.3	106.9	84.4	84.4	107.0	84.3	84.3	107.0	84.3	84.3	106.9
				SHC	61.7	84.3	106.9	61.7	84.3	106.9	61.7	84.4	107.0	61.7	84.3	107.0	61.7	84.3	106.9
62			TC	85.1	85.1	112.7	84.7	84.7	113.7	84.8	84.8	113.6	85.1	85.1	112.5	85.2	85.2	112.9	
			SHC	54.0	83.4	112.7	54.2	83.9	113.7	54.2	83.9	113.6	54.1	83.3	112.5	54.1	83.5	112.9	
67			TC	93.1	93.1	102.5	93.1	93.1	102.5	93.1	93.1	102.5	93.1	93.1	102.5	93.0	93.0	102.5	
			SHC	39.7	71.1	102.5	39.7	71.1	102.5	39.7	71.1	102.5	39.7	71.1	102.5	39.7	71.1	102.5	
72		TC	103.1	103.1	103.1	103.1	103.1	103.1	103.1	103.1	103.1	103.4	103.4	103.4	103.2	103.2	103.2		
		SHC	24.5	55.4	86.4	24.5	55.4	86.3	24.5	55.4	86.4	26.6	57.1	87.7	24.5	55.5	86.5		
76		TC	—	111.6	111.6	—	111.7	111.7	—	111.6	111.6	—	111.6	111.6	—	111.6	111.6		
		SHC	—	42.8	72.7	—	42.9	72.7	—	42.8	72.7	—	42.8	72.7	—	42.9	72.7		
7000 cfm		EA (wb)	58	TC	88.9	88.9	112.6	88.9	88.9	112.6	88.9	88.9	112.6	88.9	88.9	112.6	89.0	89.0	112.7
				SHC	65.2	88.9	112.6	65.2	88.9	112.6	65.2	88.9	112.6	65.2	88.9	112.6	65.2	89.0	112.7
	62		TC	89.0	89.0	120.6	89.0	89.0	120.6	89.0	89.0	120.6	89.0	89.0	120.6	89.0	89.0	120.6	
			SHC	57.4	89.0	120.6	57.4	89.0	120.6	57.4	89.0	120.6	57.4	89.0	120.6	57.4	89.0	120.6	
	67		TC	95.3	95.3	114.2	95.3	95.3	114.2	95.3	95.3	114.2	95.3	95.3	114.1	95.3	95.3	114.2	
			SHC	41.6	77.9	114.2	41.6	77.9	114.2	41.6	77.9	114.2	41.6	77.8	114.1	41.6	77.9	114.2	
	72	TC	105.3	105.3	105.3	105.4	105.4	105.4	105.3	105.3	105.3	105.3	105.3	105.3	105.4	105.4	105.4		
		SHC	23.8	59.6	95.5	23.8	59.6	95.5	23.8	59.6	95.5	23.8	59.6	95.5	23.8	59.6	95.5		
	76	TC	—	113.7	113.7	—	113.8	113.8	—	113.7	113.7	—	113.8	113.8	—	113.8	113.8		
		SHC	—	44.9	79.7	—	44.9	79.7	—	44.9	79.7	—	44.9	79.7	—	44.9	79.7		
	8000 cfm	EA (wb)	58	TC	92.6	92.6	117.2	92.7	92.7	117.3	92.7	92.7	117.3	92.6	92.6	117.3	92.6	92.6	117.2
				SHC	68.0	92.6	117.2	68.1	92.7	117.3	68.1	92.7	117.3	68.0	92.6	117.3	68.0	92.6	117.2
62			TC	92.7	92.7	125.4	92.7	92.7	125.4	92.7	92.7	125.4	92.7	92.7	125.4	92.7	92.7	125.5	
			SHC	59.9	92.7	125.4	59.9	92.7	125.4	59.9	92.7	125.4	59.9	92.7	125.4	60.0	92.7	125.5	
67			TC	96.7	96.7	124.5	96.8	96.8	124.5	96.7	96.7	124.5	96.8	96.8	124.5	96.8	96.8	124.6	
			SHC	43.2	83.9	124.5	43.2	83.9	124.5	43.2	83.9	124.5	43.2	83.9	124.5	43.3	83.9	124.6	
72		TC	107.1	107.1	107.1	107.0	107.0	107.0	107.0	107.0	107.0	107.0	107.0	107.0	107.1	107.1	107.1		
		SHC	23.0	63.7	104.3	23.0	63.7	104.3	23.0	63.7	104.3	23.0	63.7	104.3	25.4	65.4	105.4		
76		TC	—	115.3	115.3	—	115.3	115.3	—	115.3	115.3	—	115.2	115.2	—	115.2	115.2		
		SHC	—	46.8	86.3	—	46.8	86.2	—	46.8	86.3	—	46.8	86.2	—	46.8	86.2		
9000 cfm		EA (wb)	58	TC	95.8	95.8	121.1	95.8	95.8	121.1	95.7	95.7	121	95.7	95.7	121.1	95.6	95.6	120.9
				SHC	70.4	95.8	121.1	70.4	95.8	121.1	70.3	95.7	121	70.4	95.7	121.1	70.3	95.6	120.9
	62		TC	95.8	95.8	129.6	95.7	95.7	129.4	95.8	95.8	129.5	95.9	95.9	129.6	95.9	95.9	129.6	
			SHC	62.1	95.8	129.6	62.0	95.7	129.4	62.0	95.8	129.5	62.1	95.9	129.6	62.1	95.9	129.6	
	67		TC	98.3	98.3	135.9	98.3	98.3	135.9	98.3	98.3	135.9	98.3	98.3	135.9	98.3	98.3	135.8	
			SHC	45.1	90.5	135.9	45.1	90.5	135.9	45.1	90.5	135.9	45.1	90.5	135.9	45.1	90.5	135.8	
	72	TC	108.3	108.3	112.8	108.4	108.4	112.8	108.5	108.5	112.8	108.4	108.4	112.8	108.4	108.4	112.8		
		SHC	22.3	67.5	112.8	22.3	67.5	112.8	22.3	67.6	112.8	22.3	67.5	112.8	22.3	67.5	112.8		
	76	TC	—	116.5	116.5	—	116.4	116.4	—	116.5	116.5	—	116.4	116.4	—	116.4	116.4		
		SHC	—	48.6	92.5	—	48.6	92.5	—	48.6	92.5	—	48.6	92.4	—	48.6	92.4		

LEGEND

- db — dry bulb
- EA — Entering Air Temperature (°F)
- SHC — Sensible Heat Capacity (1000 Btuh) gross
- TC — Total Capacity (1000 Btuh) gross
- wb — wet bulb

38AUD28/40RUA28 Stage 3 Combination Ratings — 60 Hz

38AUD28/40RUA28			AMBIENT TEMPERATURE (°F)																
			85			95			105			115			125				
			EA (db)			EA (db)			EA (db)			EA (db)			EA (db)				
			75	80	85	75	80	85	75	80	85	75	80	85	75	80	85		
7500 cfm	EA (wb)	58	TC	258.8	258.8	283.0	248.5	248.5	274.2	236.5	236.5	267.2	225.5	225.5	254.8	213.3	213.3	241.1	
			SHC	219.6	251.3	283.0	212.3	243.3	274.2	205.7	236.5	267.2	196.1	225.5	254.8	185.6	213.3	241.1	
		62	TC	270.9	270.9	270.9	258.7	258.7	262.6	245.6	245.6	256.7	231.4	231.4	249.9	216.4	216.4	242.0	
			SHC	197.8	232.9	268.1	192.2	227.4	262.6	186.4	221.6	256.7	179.8	214.8	249.9	172.4	207.2	242.0	
		67	TC	294.9	294.9	294.9	282.3	282.3	282.3	267.6	267.6	267.6	252.3	252.3	252.3	235.9	235.9	235.9	
			SHC	160.9	195.7	230.6	155.7	190.8	225.8	149.9	185.0	220.2	143.8	179.2	214.5	137.4	172.8	208.1	
	72	TC	321.7	321.7	321.7	307.8	307.8	307.8	292.2	292.2	292.2	275.4	275.4	275.4	257.1	257.1	257.1		
		SHC	124.3	157.8	191.4	118.9	153.0	187.0	113.0	147.4	181.9	106.9	141.6	176.3	100.3	135.2	170.2		
	76	TC	—	345.5	345.5	—	329.2	329.2	—	310.4	310.4	—	294.8	294.8	—	274.9	274.9		
		SHC	—	125.9	167.1	—	121.2	162.4	—	115.8	144.1	—	111.0	143.2	—	104.9	138.7		
	8750 cfm	EA (wb)	58	TC	268.2	268.2	303.6	258.4	258.4	292.0	247.5	247.5	279.7	235.8	235.8	266.5	222.6	222.6	251.6
				SHC	232.9	268.2	303.6	224.8	258.4	292.0	215.3	247.5	279.7	205.1	235.8	266.5	193.7	222.6	251.6
62			TC	280.3	280.3	288.6	268.6	268.6	280.4	252.3	252.3	279.6	237.9	237.9	271.2	223.6	223.6	256.5	
			SHC	209.7	249.2	288.6	203.2	241.8	280.4	199.8	239.7	279.6	192.5	231.8	271.2	181.8	219.2	256.5	
67			TC	302.4	302.4	302.4	288.6	288.6	288.6	273.8	273.8	273.8	257.8	257.8	257.8	240.7	240.7	240.7	
			SHC	169.5	209.7	249.9	164.1	204.4	244.7	158.5	198.9	239.4	152.3	192.7	233.2	145.7	186.2	226.7	
72		TC	329.2	329.2	329.2	314.0	314.0	314.0	297.8	297.8	297.8	280.3	280.3	280.3	261.7	261.7	261.7		
		SHC	126.9	166.1	205.3	121.3	160.9	200.5	115.5	155.3	195.1	109.3	149.3	189.3	102.8	143.0	183.2		
76		TC	—	352.2	352.2	—	336.3	336.3	—	318.3	318.3	—	299.9	299.9	—	279.7	279.7		
		SHC	—	130.3	171.6	—	125.7	161.3	—	120.2	157.7	—	114.5	153.2	—	108.4	147.9		
10000 cfm		EA (wb)	58	TC	278.6	278.6	314.8	268.1	268.1	303	256.8	256.8	290.2	244.1	244.1	275.9	230.2	230.2	260.1
				SHC	242.3	278.6	314.8	233.2	268.1	303	223.4	256.8	290.2	212.4	244.1	275.9	200.2	230.2	260.1
	62		TC	283.9	283.9	313.8	271.3	271.3	306.8	257.6	257.6	297.1	245.1	245.1	284.0	230.6	230.6	268.9	
			SHC	224.4	269.1	313.8	218.2	262.5	306.8	210.3	253.7	297.1	200.8	242.4	284.0	189.8	229.4	268.9	
	67		TC	308.2	308.2	308.2	294.4	294.4	294.4	278.6	278.6	278.6	262.0	262.0	262.0	244.4	244.4	244.4	
			SHC	177.7	223.0	268.2	172.4	217.8	263.1	166.4	211.7	257.1	160.3	205.7	251.0	153.8	199.1	244.4	
	72	TC	334.9	334.9	334.9	319.2	319.2	319.2	303.1	303.1	303.1	284.5	284.5	284.5	265.3	265.3	265.3		
		SHC	129.2	173.7	218.2	123.7	168.4	213.1	118.0	162.9	207.8	111.7	156.7	201.8	105.2	150.3	195.4		
	76	TC	—	357.7	357.7	—	341.6	341.6	—	323.8	323.8	—	304.3	304.3	—	283.3	283.3		
		SHC	—	133.8	174.9	—	128.9	171.4	—	123.5	167.0	—	117.6	161.9	—	111.2	156.1		
	11250 cfm	EA (wb)	58	TC	287.4	287.4	324.7	276.5	276.5	312.4	264.1	264.1	298.4	250.8	250.8	283.4	236.4	236.4	267.1
				SHC	250.0	287.4	324.7	240.5	276.5	312.4	229.7	264.1	298.4	218.2	250.8	283.4	205.6	236.4	267.1
62			TC	288.8	288.8	332.6	276.5	276.5	322.8	264.3	264.3	309.5	253.4	253.4	284.4	236.3	236.3	277.5	
			SHC	235.3	284.0	332.6	227.9	275.3	322.8	218.3	263.9	309.5	202.6	243.5	284.4	195.2	236.3	277.5	
67			TC	313.3	313.3	313.3	298.1	298.1	298.1	282.4	282.4	282.4	265.3	265.3	268.2	247.2	247.2	261.3	
			SHC	185.7	235.8	286.0	180.0	230.2	280.4	174.3	224.4	274.6	168.0	218.1	268.2	161.3	211.3	261.3	
72		TC	339.4	339.4	339.4	324.0	324.0	324.0	306.7	306.7	306.7	287.7	287.7	287.7	268.3	268.3	268.3		
		SHC	131.3	180.8	230.3	126.0	175.6	225.3	120.1	169.9	219.8	113.7	163.6	213.5	107.3	157.3	207.3		
76		TC	—	363.0	363.0	—	346.0	346.0	—	326.9	326.9	—	307.5	307.5	—	—	—		
		SHC	—	136.8	184.1	—	131.7	179.8	—	126.0	174.8	—	120.1	169.6	—	—	—		
12500 cfm		EA (wb)	58	TC	294.7	294.7	333.0	283.1	283.1	319.9	270.9	270.9	306.2	256.9	256.9	290.4	241.6	241.6	273.0
				SHC	256.4	294.7	333.0	246.3	283.1	319.9	235.7	270.9	306.2	223.5	256.9	290.4	210.2	241.6	273.0
	62		TC	295.3	295.3	346.4	283.9	283.9	329.6	270.9	270.9	316.5	257.3	257.3	301.3	241.8	241.8	283.6	
			SHC	244.2	295.3	346.4	232.9	281.3	329.6	223.3	269.9	316.5	212.5	256.9	301.3	200.0	241.8	283.6	
	67		TC	316.6	316.6	316.6	302.1	302.1	302.1	285.5	285.5	291.3	268.2	268.2	284.8	249.5	249.5	277.6	
			SHC	193.1	248.0	302.9	187.8	242.6	297.5	181.8	236.5	291.3	175.5	230.1	284.8	168.9	223.2	277.6	
	72	TC	343.1	343.1	343.1	326.7	326.7	326.7	309.3	309.3	309.3	291.1	291.1	291.1	270.6	270.6	270.6		
		SHC	133.1	187.5	241.9	127.6	182.1	236.6	121.8	176.4	230.9	115.9	170.4	225	109.3	163.9	218.5		
	76	TC	—	366.4	366.4	—	349.4	349.4	—	330.6	330.6	—	—	—	—	—	—		
		SHC	—	139	191.8	—	134.0	187.3	—	128.4	182.3	—	—	—	—	—	—		

LEGEND

- db — dry bulb
- EA — Entering Air Temperature (°F)
- SHC — Sensible Heat Capacity (1000 Btuh) gross
- TC — Total Capacity (1000 Btuh) gross
- wb — wet bulb

38AUD28/40RUA28 Stage 2 Combination Ratings — 60 Hz

38AUD28/40RUA28			AMBIENT TEMPERATURE (°F)																
			85			95			105			115			125				
			EA (db)			EA (db)			EA (db)			EA (db)			EA (db)				
			75	80	85	75	80	85	75	80	85	75	80	85	75	80	85		
7500 cfm	EA (wb)	58	TC	212.8	212.8	233.6	202.5	202.5	226.1	193.5	193.5	213.4	181.0	181.0	204.5	169.2	169.2	191.2	
			SHC	180.7	207.2	233.6	174.4	200.2	226.1	165.3	189.3	213.4	157.5	181.0	204.5	147.3	169.2	191.2	
		62	TC	224.6	224.6	224.6	211.7	211.7	212.5	199.3	199.3	205.9	187.0	187.0	194.9	173.0	173.0	185.7	
			SHC	163.9	192.8	221.7	156.0	184.2	212.5	149.7	177.8	205.9	141.2	168.0	194.9	133.3	159.5	185.7	
		67	TC	246.8	246.8	246.8	233.3	233.3	233.3	219.0	219.0	219.0	203.6	203.6	203.6	187.5	187.5	187.5	
			SHC	135.4	164.2	192.9	129.8	158.7	187.5	124.0	153.0	182.0	117.8	146.8	175.9	111.4	140.5	169.6	
	72	TC	270.1	270.1	270.1	255.9	255.9	255.9	240.8	240.8	240.8	224.0	224.0	224.0	206.4	206.4	206.4		
		SHC	106.1	133.7	161.2	100.6	128.6	156.6	94.8	123.1	151.5	88.6	117.2	145.8	82.2	111.0	139.7		
	76	TC	—	290.6	290.6	—	275.3	275.3	—	259.3	259.3	—	242.1	242.1	—	222.8	222.8		
		SHC	—	109.1	143.4	—	104	132.7	—	98.3	127.7	—	93.1	122.9	—	87.2	114.7		
	8750 cfm	EA (wb)	58	TC	226.1	226.1	251.9	214.8	214.8	242.7	203.7	203.7	230.1	191.8	191.8	216.7	178.6	178.6	201.8
				SHC	194.7	223.3	251.9	186.9	214.8	242.7	177.2	203.7	230.1	166.9	191.8	216.7	155.5	178.6	201.8
62			TC	232.8	232.8	239.5	220.4	220.4	233.3	208.2	208.2	223.3	194.5	194.5	213.4	179.7	179.7	203.2	
			SHC	174.1	206.8	239.5	168.2	200.8	233.3	160.3	191.8	223.3	152.0	182.7	213.4	143.8	173.5	203.2	
67			TC	254.7	254.7	254.7	240.7	240.7	240.7	225.7	225.7	225.7	209.8	209.8	209.8	192.6	192.6	192.6	
			SHC	144.1	178.1	212	138.5	172.5	206.6	132.6	166.6	200.7	126.4	160.5	194.5	119.3	153.2	187.1	
72		TC	278.9	278.9	278.9	263.4	263.4	263.4	247.3	247.3	247.3	230.1	230.1	230.1	211.9	211.9	211.9		
		SHC	109.3	142.5	175.6	103.6	137.0	170.4	97.7	131.4	165.0	91.6	125.4	159.2	85.3	119.1	152.9		
76		TC	—	299.1	299.1	—	283.7	283.7	—	266.5	266.5	—	248	248	—	228.1	228.1		
		SHC	—	112.4	146.7	—	108.2	143.1	—	102.9	134.4	—	97.2	129.9	—	91.0	124.4		
10000 cfm		EA (wb)	58	TC	235.6	235.6	266.2	224.8	224.8	254	213.1	213.1	240.7	200.3	200.3	226.4	186.5	186.5	210.7
				SHC	205.0	235.6	266.2	195.6	224.8	254	185.4	213.1	240.7	174.3	200.3	226.4	162.3	186.5	210.7
	62		TC	241.0	241.0	256.2	228.1	228.1	250.6	214.6	214.6	241.7	200.9	200.9	232.0	186.7	186.7	218.8	
			SHC	184.2	220.2	256.2	178.6	214.6	250.6	171.3	206.5	241.7	163.8	197.9	232.0	154.4	186.6	218.8	
	67		TC	260.8	260.8	260.8	246.6	246.6	246.6	230.9	230.9	230.9	213.7	213.7	213.7	196.3	196.3	202.2	
			SHC	152.3	191.2	230.1	146.7	185.7	224.6	140.8	179.7	218.7	133.7	172.5	211.3	126.0	164.1	202.2	
	72	TC	284.5	284.5	284.5	269.1	269.1	269.1	252.3	252.3	252.3	234.9	234.9	234.9	215.6	215.6	215.6		
		SHC	111.8	150.1	188.5	106.3	144.8	183.3	100.4	139.1	177.7	94.4	133.1	171.8	87.8	126.6	165.4		
	76	TC	—	305.1	305.1	—	289.3	289.3	—	271.6	271.6	—	252.4	252.4	—	232.0	232.0		
		SHC	—	116.6	151.8	—	111.9	148.7	—	106.5	144.1	—	100.6	138.8	—	94.3	132.8		
	11250 cfm	EA (wb)	58	TC	244.4	244.4	276.1	232.9	232.9	263.1	220.4	220.4	249.0	207.0	207.0	233.9	192.5	192.5	217.5
				SHC	212.6	244.4	276.1	202.6	232.9	263.1	191.8	220.4	249.0	180.1	207.0	233.9	167.5	192.5	217.5
62			TC	246.6	246.6	277.7	234.0	234.0	269.3	221.1	221.1	256.6	207.2	207.2	241.9	192.6	192.6	225.9	
			SHC	197.0	237.3	277.7	190.3	229.8	269.3	181.4	219.0	256.6	170.8	206.3	241.9	159.3	192.6	225.9	
67			TC	265.5	265.5	265.5	250.5	250.5	250.5	234.2	234.2	234.9	217.5	217.5	226.4	200.1	200.1	213.8	
			SHC	160.0	203.7	247.4	154.4	198.1	241.8	147.8	191.4	234.9	140.4	183.4	226.4	131.0	172.4	213.8	
72		TC	289.3	289.3	289.3	273.3	273.3	273.3	256.2	256.2	256.2	238.2	238.2	238.2	218.6	218.6	218.6		
		SHC	114.1	157.4	200.6	108.6	152.0	195.3	102.8	146.2	189.7	96.8	140.2	183.7	90.3	133.7	177.1		
76		TC	—	310.5	310.5	—	293.3	293.3	—	274.9	274.9	—	255.3	255.3	—	234.9	234.9		
		SHC	—	120.2	161.7	—	114.9	157.2	—	109.3	152.1	—	103.4	146.5	—	97.1	140.4		
12500 cfm		EA (wb)	58	TC	251.7	251.7	284.4	239.7	239.7	270.9	226.8	226.8	256.3	210.3	213.0	240.7	197.8	197.8	223.5
				SHC	219	251.7	284.4	208.6	239.7	270.9	197.4	226.8	256.3	185.4	213.0	240.7	172.1	197.8	223.5
	62		TC	253.3	253.3	289.5	240.9	240.9	278.7	228.3	228.3	260.4	213.1	213.1	249.9	197.7	197.7	231.8	
			SHC	205.5	247.5	289.5	197.2	237.9	278.7	184.9	222.6	260.4	176.3	213.1	249.9	163.5	197.7	231.8	
	67		TC	269.7	269.7	269.7	253.6	253.6	257.4	237.5	237.5	249.7	220.4	220.4	237.9	203.6	203.6	224.0	
			SHC	167.6	216.0	264.3	161.2	209.3	257.4	154.3	202.0	249.7	145.3	191.6	237.9	135.7	179.9	224.0	
	72	TC	293.0	293.0	293.0	276.8	276.8	276.8	259.2	259.2	259.2	241.3	241.3	241.3	220.8	220.8	220.8		
		SHC	116.2	164.1	212.1	110.7	158.8	206.8	105.0	153.0	201.1	99.0	147.0	195.1	92.4	140.3	188.2		
	76	TC	—	313.8	313.8	—	296.8	296.8	—	278.4	278.4	—	258.4	258.4	—	237.3	237.3		
		SHC	—	122.7	169.5	—	117.6	164.9	—	112.0	159.7	—	106	153.9	—	99.5	147.4		

LEGEND

- db — dry bulb
- EA — Entering Air Temperature (°F)
- SHC — Sensible Heat Capacity (1000 Btuh) gross
- TC — Total Capacity (1000 Btuh) gross
- wb — wet bulb

38AUD28/40RUA28 Stage 1 Combination Ratings — 60 Hz

38AUD28/40RUA28			AMBIENT TEMPERATURE (°F)																
			85			95			105			115			125				
			EA (db)			EA (db)			EA (db)			EA (db)			EA (db)				
			75	80	85	75	80	85	75	80	85	75	80	85	75	80	85		
7500 cfm	EA (wb)	58	TC	91.8	91.8	106	92.3	92.3	107.0	90.8	90.8	109.9	92.4	92.4	105.4	90.7	90.7	110.1	
			SHC	70.1	88.0	106	70.6	88.8	107.0	71.3	90.6	109.9	70.0	87.7	105.4	71.3	90.7	110.1	
		62	TC	91.0	91.0	101.0	91.0	91.0	100.9	91.0	91.0	101.1	91.0	91.0	100.9	91.0	91.0	101.0	
			SHC	54.7	77.9	101.0	54.7	77.8	100.9	54.7	77.9	101.1	54.7	77.8	100.9	54.7	77.9	101.0	
		67	TC	99.7	99.7	99.7	99.7	99.7	99.7	99.7	99.7	99.7	99.7	99.7	99.7	99.7	99.8	99.8	
			SHC	42.2	64.9	87.5	42.2	64.9	87.5	42.3	64.9	87.6	42.3	65.0	87.7	42.3	65.0	87.7	
	72	TC	109.2	109.2	109.2	109.2	109.2	109.2	109.2	109.2	109.2	109.2	109.2	109.2	109.2	109.2	109.2		
		SHC	31.2	52.0	72.7	31.2	52.0	72.7	31.2	51.9	72.6	31.2	52.0	72.7	31.2	52.0	72.7		
	76	TC	—	117.3	117.3	—	117.3	117.3	—	117.3	117.3	—	117.3	117.3	—	117.3	117.3		
		SHC	—	41.7	76.1	—	41.7	76.1	—	41.7	76.1	—	41.7	76.1	—	41.7	76.1		
	8750 cfm	EA (wb)	58	TC	96.3	96.3	116.2	96.3	96.3	116.2	96.3	96.3	116.2	96.3	96.3	116.2	96.3	96.3	116.2
				SHC	76.5	96.3	116.2	76.5	96.3	116.2	76.4	96.3	116.2	76.4	96.3	116.2	76.5	96.3	116.2
62			TC	95.6	95.6	115.2	95.5	95.5	115.2	95.5	95.5	115.3	95.6	95.6	115.2	95.6	95.6	115.2	
			SHC	63.0	89.1	115.2	63.0	89.1	115.2	63.0	89.1	115.3	62.9	89.1	115.2	63.0	89.1	115.2	
67			TC	103.1	103.1	103.1	103.1	103.1	103.1	103.1	103.1	103.1	103.1	103.1	103.1	103.1	103.1	103.1	
			SHC	44.5	71.0	97.5	44.6	71	97.5	44.6	71.1	97.6	44.5	71.1	97.7	44.6	71.1	97.6	
72		TC	112.7	112.7	112.7	112.7	112.7	112.7	112.7	112.7	112.7	112.7	112.7	112.7	112.7	112.7	112.7		
		SHC	30.1	55.7	81.3	30.1	55.7	81.3	30.1	55.7	81.3	30.1	55.7	81.3	30.1	55.7	81.3		
76		TC	—	120.7	120.7	—	120.7	120.7	—	120.7	120.7	—	120.7	120.7	—	120.7	120.7		
		SHC	—	42.5	83.8	—	42.5	83.8	—	42.5	83.8	—	42.5	83.8	—	42.5	83.8		
10000 cfm		EA (wb)	58	TC	100.5	100.5	120.6	100.5	100.5	120.7	100.4	100.4	120.6	100.4	100.4	120.6	100.4	100.4	120.6
				SHC	80.3	100.5	120.6	80.3	100.5	120.7	80.3	100.4	120.6	80.3	100.4	120.6	80.3	100.4	120.6
	62		TC	100.7	100.7	126.7	101.9	101.9	120.2	101.2	101.2	122.8	102.8	102.8	122.3	101.1	101.1	123.9	
			SHC	73.5	100.1	126.7	71.3	95.8	120.2	72.2	97.5	122.8	72.3	97.3	122.3	72.5	98.2	123.9	
	67		TC	105.8	105.8	107.2	105.8	105.8	107.2	105.8	105.8	107.2	105.8	105.8	107.2	105.9	105.9	107.2	
			SHC	47.3	77.3	107.2	47.2	77.2	107.2	47.3	77.2	107.2	47.2	77.2	107.2	47.3	77.2	107.2	
	72	TC	115.2	115.2	115.2	115.4	115.4	115.4	115.2	115.2	115.2	115.2	115.2	115.2	115.2	115.2	115.2		
		SHC	29.7	59.2	88.6	29.7	59.2	88.6	29.7	59.2	88.6	29.7	59.2	88.6	29.7	59.1	88.6		
	76	TC	—	122.9	122.9	—	123.0	123.0	—	122.9	122.9	—	122.9	122.9	—	123.0	123.0		
		SHC	—	43.9	69.4	—	43.9	69.3	—	43.9	69.4	—	43.9	69.4	—	43.9	69.3		
	11250 cfm	EA (wb)	58	TC	103.7	103.7	124.0	103.8	103.8	124.2	103.8	103.8	124.1	103.7	103.7	124.1	103.7	103.7	124.1
				SHC	83.4	103.7	124.0	83.5	103.8	124.2	83.4	103.8	124.1	83.4	103.7	124.1	83.4	103.7	124.1
62			TC	106.0	106.0	122.6	103.8	103.8	130.8	103.8	103.8	130.9	103.8	103.8	130.9	103.8	103.8	130.9	
			SHC	74.0	98.3	122.6	76.7	103.8	130.8	76.8	103.8	130.9	76.8	103.8	130.9	76.8	103.8	130.9	
67			TC	107.8	107.8	114.6	107.8	107.8	115	107.9	107.9	116.6	107.8	107.8	116.3	107.9	107.9	116.5	
			SHC	50.1	82.4	114.6	50.2	82.6	115	50.6	83.6	116.6	50.5	83.4	116.3	50.6	83.5	116.5	
72		TC	117.3	117.3	117.3	117.3	117.3	117.3	117.3	117.3	117.3	117.3	117.3	117.3	117.3	117.3	117.3		
		SHC	29.3	62.2	95.0	29.3	62.2	95.0	29.3	62.2	95.0	29.3	62.2	95.0	29.3	62.2	95.0		
76		TC	—	124.9	124.9	—	125.0	125.0	—	124.9	124.9	—	124.9	124.9	—	124.9	124.9		
		SHC	—	44.6	75.7	—	44.6	75.5	—	44.6	75.7	—	44.6	75.7	—	44.6	75.7		
12500 cfm		EA (wb)	58	TC	106.5	106.5	126.9	106.5	106.5	126.9	106.6	106.6	127.1	106.6	106.6	127.1	106.5	106.5	127.0
				SHC	86.0	106.5	126.9	86.0	106.5	126.9	86.1	106.6	127.1	86.1	106.6	127.1	86.1	106.5	127.0
	62		TC	107.8	107.8	125.6	106.7	106.7	133.9	106.5	106.5	133.8	106.7	106.7	133.9	106.6	106.6	133.8	
			SHC	76.2	100.9	125.6	79.4	106.7	133.9	79.3	106.5	133.8	79.4	106.7	133.9	79.3	106.6	133.8	
	67		TC	109.7	109.7	125.6	109.7	109.7	125.7	109.7	109.7	125.7	109.7	109.7	125.8	109.7	109.7	125.6	
			SHC	53.9	89.7	125.6	54.0	89.8	125.7	54.0	89.8	125.7	54.0	89.9	125.8	54.0	89.8	125.6	
	72	TC	118.8	118.8	118.8	118.8	118.8	118.8	118.8	118.8	118.8	118.8	118.8	118.8	118.8	118.8	118.8		
		SHC	28.8	64.8	100.8	28.8	64.8	100.8	28.8	64.8	100.8	28.8	64.8	100.8	28.8	64.8	100.8		
	76	TC	—	126.5	126.5	—	126.6	126.6	—	127.4	127.4	—	126.6	126.6	—	126.5	126.5		
		SHC	—	44.7	80.0	—	44.7	80.0	—	45	80.2	—	44.7	80.0	—	44.7	80.0		

LEGEND

- db — dry bulb
- EA — Entering Air Temperature (°F)
- SHC — Sensible Heat Capacity (1000 Btuh) gross
- TC — Total Capacity (1000 Btuh) gross
- wb — wet bulb

38AUZ 07-14 without Powered Convenience Outlet

UNIT SIZE	NUMBER OF STAGES	V-Ph-Hz	VOLTAGE RANGE		COMPRESSOR NO. 1		COMPRESSOR NO. 2		OFM		POWER SUPPLY		DISCONNECT SIZE	
			Min	Max	RLA	LRA	RLA	LRA	Qty	FLA (ea)	MCA	Fuse or HACR Breaker	FLA	LRA
07	2	208/230-3-60	187	253	17.5	136	—	—	2	1.5	25/25	30/30	24/24	142/142
		460-3-60	414	506	8.4	66	—	—	2	0.8	13	20	12	70
		575-3-60	518	633	6.3	55	—	—	2	0.7	10	15	9	59
08	2	208/230-3-60	187	253	26.8	164	—	—	2	1.5	37/37	60/60	34/34	170/170
		460-3-60	414	506	12.6	100	—	—	2	0.8	18	25	16	104
		575-3-60	518	633	9.9	78	—	—	2	0.7	14	20	13	82
12	2	208/230-3-60	187	253	33.2	240	—	—	2	1.5	45/45	60/60	42/42	246/246
		460-3-60	414	506	15.1	130	—	—	2	0.8	21	30	19	134
		575-3-60	518	633	11.4	94	—	—	2	0.7	16	25	15	98
14	2	208/230-3-60	187	253	19.6	136	19.6	136	2	1.5	48/48	60/60	49/49	278/278
		460-3-60	414	506	8.2	66	8.2	66	2	0.8	21	25	21	136
		575-3-60	518	633	6.6	55	6.6	55	2	0.7	17	20	17	114

38AUZ 07-14 with Powered Convenience Outlet

UNIT SIZE	NUMBER OF STAGES	V-Ph-Hz	VOLTAGE RANGE		COMPRESSOR NO. 1		COMPRESSOR NO. 2		OFM		POWER SUPPLY		DISCONNECT SIZE	
			Min	Max	RLA	LRA	RLA	LRA	Qty	FLA (ea)	MCA	Fuse or HACR Breaker	FLA	LRA
07	2	208/230-3-60	187	253	17.5	136	—	—	2	1.5	30/30	45/45	29/29	147/147
		460-3-60	414	506	8.4	66	—	—	2	0.8	15	20	14	72
		575-3-60	518	633	6.3	55	—	—	2	0.7	11	15	11	61
08	2	208/230-3-60	187	253	26.8	164	—	—	2	1.5	42/42	60/60	40/40	175/175
		460-3-60	414	506	12.6	100	—	—	2	0.8	20	30	19	106
		575-3-60	518	633	9.9	78	—	—	2	0.7	16	25	15	84
12	2	208/230-3-60	187	253	33.2	240	—	—	2	1.5	50/50	60/60	47/47	251/251
		460-3-60	414	506	15.1	130	—	—	2	0.8	23	30	22	136
		575-3-60	518	633	11.4	94	—	—	2	0.7	18	25	17	100
14	2	208/230-3-60	187	253	19.6	136	19.6	136	2	1.5	52/52	60/60	54/54	283/283
		460-3-60	414	506	8.2	66	8.2	66	2	0.8	23	30	23	138
		575-3-60	518	633	6.6	55	6.6	55	2	0.7	18	20	19	116

LEGEND

FLA — Full Load Amps
LRA — Locked Rotor Amps
OFM — Outdoor Fan Motor

38AUZ 16, 25 without Powered Convenience Outlet

UNIT SIZE	NUMBER OF STAGES	NOMINAL POWER SUPPLY	VOLTAGE RANGE		COMPRESSOR No. 1		COMPRESSOR No. 2		OFM		POWER SUPPLY		DISCONNECT SIZE	
			V-Ph-Hz	Min	Max	RLA	LRA	RLA	LRA	Qty	FLA (ea)	MCA	Fuse or HACR Brkr	FLA
16	2	208/230-3-60	187	253	25.0	164	25.0	164	3	1.5	60.8/60.8	80/80	63/63	337/337
	2	460-3-60	414	506	12.2	100	12.2	100	3	0.8	29.9	40	31	206
	2	575-3-60	518	633	9.0	78	9.0	78	3	0.7	22.4	30	23	162
25	2	208/230-3-60	187	253	30.1	225	30.1	225	4	1.5	73.7/73.7	100/100	76/76	462/462
	2	460-3-60	414	506	16.7	114	16.7	114	4	0.8	40.8	50	42	236
	2	575-3-60	518	633	12.2	80	12.2	80	4	0.7	30.3	40	31	168

38AUZ 16, 25 with Powered Convenience Outlet

UNIT SIZE	NUMBER OF STAGES	NOMINAL POWER SUPPLY	VOLTAGE RANGE		COMPRESSOR No. 1		COMPRESSOR No. 2		OFM		POWER SUPPLY		DISCONNECT SIZE	
			V-Ph-Hz	Min	Max	RLA	LRA	RLA	LRA	Qty	FLA (ea)	MCA	Fuse or HACR Brkr	FLA
16	2	208/230-3-60	187	253	25.0	164	25.0	164	3	1.5	65.6/65.6	90/90	68/68	342/342
	2	460-3-60	414	506	12.2	100	12.2	100	3	0.8	32.1	40	33	208
	2	575-3-60	518	633	9.0	78	9.0	78	3	0.7	24.1	30	25	164
25	2	208/230-3-60	187	253	30.1	225	30.1	225	4	1.5	78.5/78.5	100/100	82/82	467/467
	2	460-3-60	414	506	16.7	114	16.7	114	4	0.8	43	50	45	238
	2	575-3-60	518	633	12.2	80	12.2	80	4	0.7	32	40	33	170

38AUD 12-14 without Powered Convenience Outlet

UNIT SIZE	NUMBER OF STAGES	NOMINAL POWER SUPPLY	VOLTAGE RANGE		COMPRESSOR No. 1		COMPRESSOR No. 2		OFM		POWER SUPPLY		DISCONNECT SIZE	
			V-Ph-Hz	Min	Max	RLA	LRA	RLA	LRA	Qty	FLA (ea)	MCA	Fuse or HACR Brkr	FLA
12	3	208/230-3-60	187	253	16.4	110	15.6	110	2	1.5	40/40	50/50	40/40	226/226
	3	460-3-60	414	506	6.8	55	7.7	52	2	0.8	18	25	19	111
	3	575-3-60	518	633	6.4	48	5.8	39	2	0.7	16	20	16	91
14	3	208/230-3-60	187	253	17.5	136	19.6	136	2	1.5	45/45	60/60	46/46	278/278
	3	460-3-60	414	506	8.4	66	8.2	66	2	0.8	21	25	21	136
	3	575-3-60	518	633	6.6	55	6.6	55	2	0.7	17	20	17	114

38AUD 12-14 with Powered Convenience Outlet

UNIT SIZE	NUMBER OF STAGES	NOMINAL POWER SUPPLY	VOLTAGE RANGE		COMPRESSOR No. 1		COMPRESSOR No. 2		OFM		POWER SUPPLY		DISCONNECT SIZE	
			V-Ph-Hz	Min	Max	RLA	LRA	RLA	LRA	Qty	FLA (ea)	MCA	Fuse or HACR Brkr	FLA
12	3	208/230-3-60	187	253	16.4	110	15.6	110	2	1.5	44/44	60/60	46/46	231/231
	3	460-3-60	414	506	6.8	55	7.7	52	2	0.8	21	25	21	113
	3	575-3-60	518	633	6.4	48	5.8	39	2	0.7	17	20	18	93
14	3	208/230-3-60	187	253	17.5	136	19.6	136	2	1.5	50/50	60/60	52/52	283/283
	3	460-3-60	414	506	8.4	66	8.2	66	2	0.8	23	30	23	138
	3	575-3-60	518	633	6.6	55	6.6	55	2	0.7	18	20	19	116

LEGEND

- HACR** — Heating, Air Conditioning and Refrigeration
- FLA** — Full Load Amps
- LRA** — Locked Rotor Amps
- MCA** — Minimum Circuit Amps
- OFM** — Outdoor Fan Motor
- RLA** — Rated Load Amps

38AUD 16-28 without Powered Convenience Outlet

UNIT SIZE	NUMBER OF STAGES	NOMINAL POWER SUPPLY V-Ph-Hz	VOLTAGE RANGE		COMPRESSOR No. 1		COMPRESSOR No. 2		OFM		POWER SUPPLY		DISCONNECT SIZE	
			Min	Max	RLA	LRA	RLA	LRA	Qty	FLA (ea)	MCA	Fuse or HACR Brkr	FLA	LRA
16	3	208/230-3-60	187	253	26.8	164	25.0	164	3	1.5	63/63	80/80	65/65	337/337
	3	460-3-60	414	506	12.0	94	12.2	100	3	0.8	29.7	40	31	200
	3	575-3-60	518	633	9.0	65	9.9	78	3	0.7	23.5	30	24	149
25	3	208/230-3-60	187	253	32.5	240	28.2	240	4	1.5	74.8/74.8	100/100	77/77	492/492
	3	460-3-60	414	506	14.8	130	14.7	130	4	0.8	36.4	50	38	268
	3	575-3-60	518	633	11.1	94	11.3	94	4	0.7	28	35	29	196
28	3	208/230-3-60	187	253	35.3	240	48.4	245	4	1.5	101.8/101.8	150/150	103/103	497/497
	3	460-3-60	414	506	17.0	140	19.0	125	4	0.8	44	60	45	273
	3	575-3-60	518	633	13.0	108	16.0	100	4	0.7	35.8	50	37	216

38AUD 16-28 with Powered Convenience Outlet

UNIT SIZE	NUMBER OF STAGES	NOMINAL POWER SUPPLY V-Ph-Hz	VOLTAGE RANGE		COMPRESSOR No. 1		COMPRESSOR No. 2		OFM		POWER SUPPLY		DISCONNECT SIZE	
			Min	Max	RLA	LRA	RLA	LRA	Qty	FLA (ea)	MCA	Fuse or HACR Brkr	FLA	LRA
16	3	208/230-3-60	187	253	26.8	164	25.0	164	3	1.5	67.8/67.8	90/90	70/70	342/342
	3	460-3-60	414	506	12.0	94	12.2	100	3	0.8	31.9	40	33	202
	3	575-3-60	518	633	9.0	65	9.9	78	3	0.7	25.2	30	26	151
25	3	208/230-3-60	187	253	32.5	240	28.2	240	4	1.5	79.6/79.6	100/100	82/82	497/497
	3	460-3-60	414	506	14.8	130	14.7	130	4	0.8	38.6	50	40	270
	3	575-3-60	518	633	11.1	94	11.3	94	4	0.7	29.7	40	31	198
28	3	208/230-3-60	187	253	35.3	240	48.4	245	4	1.5	106.6/106.6	150/150	109/109	502/502
	3	460-3-60	414	506	17.0	140	19.0	125	4	0.8	46.2	60	48	275
	3	575-3-60	518	633	13.0	108	16.0	100	4	0.7	37.5	50	39	218

LEGEND

HACR	— Heating, Air Conditioning and Refrigeration
FLA	— Full Load Amps
LRA	— Locked Rotor Amps
MCA	— Minimum Circuit Amps
OFM	— Outdoor Fan Motor
RLA	— Rated Load Amps

Operating Limits

- Maximum outdoor temperature..... 125°F
 Minimum return-air temperature (40RFA/RUA)..... 55°F
 Maximum return-air temperature (40RFA/RUA)..... 95°F
 Range of acceptable saturation
 suction temperature..... 20 to 50°F
 Maximum discharge temperature..... 275°F
 Minimum discharge superheat..... 60°F
1. Select air handler at no less than 300 cfm/ton (nominal condensing unit capacity).
 2. Total combined draw of the field-supplied liquid line solenoid valve and air handler fan contactor must not exceed 22 va. If the specified va must be exceeded, use a remote relay to control the load.

Minimum Outdoor-Air Operating Temperature

UNIT 38AU	MAXIMUM OUTDOOR TEMP (°F)	
	Std	With Low Ambient Control ^a
Z07	35	-20
Z08	35	
D12	35	
D14	35	
D16	35	
D25	35	
D28	35	

NOTE(S):

- Wind baffles (field-supplied and field-installed) are recommended for all units with low ambient control. Refer to Low Ambient Temperature Control Installation Instructions for additional information.

Refrigerant Piping

IMPORTANT: Do not bury refrigerant piping underground.

It is recommended that the refrigerant piping for all commercial split systems include a liquid line solenoid valve, a liquid line filter drier and a sight glass.

For refrigerant lines longer than 75 lineal ft, a liquid line solenoid valve installed at the indoor unit and a suction accumulator are required. Refer to the Refrigerant Specialties Part Numbers table.

Refrigerant Specialties Part Numbers

LIQUID LINE SIZE (in.)	LIQUID LINE SOLENOID VALVE (LLSV)	LLSV COIL	SIGHT GLASS
3/8	EF680033	EF680037	KM680008
1/2	EF680035	EF680037	KM680004
5/8	EF680036	EF680037	KM680005

Commercial Air-Cooled Condensing Units HVAC Guide Specifications

Size Range: **6 to 25 Tons**

Carrier Model Numbers: **38AUZ, Single Circuit (07-25 Models) 38AUD, Dual Circuit (12-28 Models)**

Part 1 — GENERAL

1.01 SYSTEM DESCRIPTION

Outdoor-mounted, air-cooled condensing unit suitable for on-the-ground or rooftop installation. Unit shall consist of a hermetic scroll air-conditioning compressor(s) assembly, an air-cooled coil, propeller-type condenser fans, and a control box. Unit shall discharge supply air upward as shown on contract drawings. Unit shall be used in a refrigeration circuit matched with a packaged air-handling unit.

1.02 QUALITY ASSURANCE

- A. Unit shall be rated in accordance with AHRI Standard 340/360.
- B. Unit construction shall comply with ANSI/ASHRAE 15 safety code latest revision and comply with NEC.
- C. Unit shall be constructed in accordance with UL 1995 standard and shall carry the UL and UL, Canada label.
- D. Unit cabinet shall be capable of withstanding 500-hour salt spray exposure per ASTM B117 (scribed specimen).
- E. Air-cooled condenser coils for hermetic scroll compressor units 38AUZ and 38AUD shall be leak tested at 150 psig, and pressure tested at 650 psig.
- F. Unit shall be manufactured in a facility registered to ISO 9001:2015 manufacturing quality standard.

1.03 DELIVERY, STORAGE, AND HANDLING

Unit shall be shipped as single package only, and shall be stored and handled according to unit manufacturer's recommendations.

1.04 WARRANTY (FOR INCLUSION BY SPECIFYING ENGINEER.)

Part 2 — PRODUCTS

2.01 EQUIPMENT

A. General:

Factory-assembled, single piece, air-cooled condensing unit. Contained within the unit enclosure shall be all factory wiring, piping, controls, compressor, holding charge, and special features required prior to field start-up.

B. Unit Cabinet:

1. Unit cabinet shall be constructed of galvanized steel, bonderized and coated with a prepainted baked enamel finish.
2. A heavy-gauge roll-formed perimeter base rail with forklift slots and lifting holes shall be provided to facilitate rigging.

C. Condenser Fans:

1. Condenser fans shall be direct driven, propeller type, discharging air vertically upward.
2. Fan blades shall be balanced.
3. Condenser fan discharge openings shall be equipped with PVC-coated steel wire safety guards.
4. Condenser fan and motor shaft shall be corrosion resistant.

D. Compressor:

1. Compressor shall be of the hermetic scroll type.
2. Compressor shall be mounted on rubber grommets.
3. Compressors shall include overload protection.
4. Compressors shall be equipped with a crank-case heater.
5. Compressor shall be equipped with internal high pressure and high temperature protection.

E. Condenser Coils:

1. Standard Aluminum fin - Copper Tube Coils:
 - a. Standard evaporator and condenser coils shall have aluminum lanced plate fins mechanically bonded to seamless internally grooved copper tubes with all joints brazed.
 - b. Evaporator coils shall be leak tested to 150 psig, pressure tested to 450 psig, and qualified to UL 1995 burst test at 1775 psig.
 - c. Condenser coils shall be leak tested to 150 psig, pressure tested to 650 psig, and qualified to UL 1995 burst test at 1980 psig.
2. Optional copper-fin evaporator and condenser coils:
 - a. Shall be constructed of copper fins mechanically bonded to copper tubes and copper tube sheets.
 - b. Galvanized steel tube sheets shall not be acceptable.
 - c. A polymer strip shall prevent coil assembly from contacting the sheet metal coil pan to minimize potential for galvanic corrosion between coil and pan.
3. Optional e-coated aluminum-fin evaporator and condenser coils:
 - a. Shall have a flexible epoxy polymer coating uniformly applied to all coil surface areas without material bridging between fins.
 - b. Coating process shall ensure complete coil encapsulation of tubes, fins and headers.
 - c. Color shall be high gloss black with gloss per ASTM D523-89.
 - d. Uniform dry film thickness from 0.8 to 1.2 mil on all surface areas including fin edges.

- e. Superior hardness characteristics of 2H per ASTM D3363-92A and cross-hatch adhesion of 4B-5B per ASTM D3359-93.
 - f. Impact resistance shall be up to 160 in.-lb (ASTM D2794-93).
 - g. Humidity and water immersion resistance shall be up to minimum 1000 and 250 hours respectively (ASTM D2247-92 and ASTM D870-92).
 - h. Corrosion durability shall be confirmed through testing to be no less than 1000 hours salt spray per ASTM B117-90.
4. Optional e-coated aluminum-fin, aluminum tube condenser coils:
- a. Shall have a flexible epoxy polymer coating uniformly applied to all coil external surface areas without material bridging between fins or louvers.
 - b. Coating process shall ensure complete coil encapsulation, including all exposed fin edges.
 - c. E-coat thickness of 0.8 to 1.2 mil with top coat having a uniform dry film thickness from 1.0 to 2.0 mil on all external coil surface areas, including fin edges, shall be provided.
 - d. Shall have superior hardness characteristics of 2H per ASTM D3363-00 and crosshatch adhesion of 4B-5B per ASTM D3359-02.
 - e. Shall have superior impact resistance with no cracking, chipping or peeling per NSF/ANSI 51-2002 Method 10.2.

F. Refrigeration Components:

Refrigeration circuit components shall include liquid line service valve, suction line service valve, a full charge of compressor oil, and a partial holding charge of refrigerant.

G. Controls and Safeties:

- 1. Minimum control functions shall include:
 - a. Control wire terminal blocks.
 - b. Compressor lockout on auto-reset safety until reset from thermostat.
 - c. Each unit shall utilize the Comfort Alert™ Diagnostic Board that provides:
 - 1) System Pressure Trip fault code indication
 - 2) Short Cycling fault code indication
 - 3) Locked Rotor fault code indication
 - 4) Open Circuit fault code indication
 - 5) Reverse Phase 3 fault code indication
 - 6) Welded Contactor fault code indication
 - 7) Low Voltage fault code indication
 - 8) Anti-short cycle protection
 - 9) Phase reversal protection

d. Minimum safety devices which are equipped with automatic reset (after resetting first at thermostat), shall include:

- 1) High discharge pressure cutout.
- 2) Low pressure cutout.

H. Operating Characteristics:

- 1. The capacity of the condensing unit shall meet or exceed _____ Btuh at a suction temperature of _____ °F/C. The power consumption at full load shall not exceed _____ kW.
- 2. The combination of the condensing unit and the evaporator or fan coil unit shall have a total net cooling capacity of _____ Btuh or greater at conditions of _____ cfm entering-air temperature at the evaporator at _____ °F/C wet bulb and _____ °F/C dry bulb, and air entering the condensing unit at _____ °F/C.
- 3. The system shall have an EER of _____ Btuh/Watt or greater at standard AHRI conditions.
- 4. Standard unit shall be capable to operate up to 125°F (52°C) and down to 40°F (4°C)

I. Electrical Requirements:

- 1. Nominal unit electrical characteristics shall be _____ v, 3-ph, _____ Hz. The unit shall be capable of satisfactory operation within voltage limits of _____ v to _____ v.
- 2. Unit electrical power shall be single-point connection.
- 3. Unit control circuit shall contain a 24-v transformer for unit control.

J. Special Features:

- 1. Low-Ambient Temperature Control:

A low-ambient temperature control shall be available as a factory-installed option or as a field-installed accessory. This low-ambient control shall regulate speed of the condenser-fan motors in response to the saturated condensing temperature of the unit. The control shall maintain correct condensing pressure at outdoor temperatures down to -20°F (-29°C).
- 2. Unit-Mounted, Non-Fused Disconnect Switch:

Switch shall be factory-installed and internally mounted. NEC and UL-approved non-fused switch shall provide unit power shutoff. Switch shall be accessible from outside the unit and shall provide power off lockout capability. Non-fused disconnect cannot be used when unit MOCP electrical rating exceeds 80 amps.
- 3. Thermostat Controls:
 - a. Programmable multi-stage thermostat shall have 7-day clock, holiday scheduling, large backlit display, re-mote sensor capability, and Title 24 compliance.

Guide specifications (cont)



- b. Commercial Electronic Thermostat shall have 7-day time clock, auto-changeover, multi-stage capability, and large LCD (liquid crystal display) temperature display.
- 4. Louvered Hail Guard Package:
Louvered hail guard package shall protect coils against damage from hail and other flying debris.
- 5. Condenser Coil Grille:
Grille shall add decorative appearance to unit and protect condenser coil from large objects and vandalism.







