



Product Data

Aquazone™ Large Capacity Water Source Heat Pumps

6 to 30 Nominal Tons



50HQP072-242, 50VQP072-360
Large Capacity Water Source Heat Pumps
with Puron® Refrigerant (R-410A)

Carrier's Aquazone™ large capacity units offer low cost, energy efficient solutions for all challenging water source heat pump applications.

Single-packaged, vertical and horizontal water source heat pumps (WSHPs):

- Performance is in accordance with AHRI/ISO/ASHRAE 13256-1
- Capable of use in a wide variety of applications, including boiler/tower loop and geothermal loop
- Dual, independent refrigerant circuits with two-stage cooling and heating
- High-efficiency scroll compressors
- Bi-flow thermal expansion valve (TXV) for reliable heat pump heating and cooling operation
- Non-ozone depleting Puron refrigerant (R-410A)
- Commercial grade construction using heavy-gauge galvanized steel
- Easy service access with large access panels
- Efficient DWDI forward curve blowers with adjustable belt drive
- Factory installed unit protection module provides reliable operation and easy troubleshooting

Operating efficiency

Carrier's Aquazone™ large capacity water source heat pumps are designed for quality and high performance over a lifetime of operation. Aquazone™ units offer cooling EERs (Energy Efficiency Ratio) to 24.0 and heating COPs (Coefficient of Performance) to 5.6. Efficiencies stated are in accordance with standard conditions under ISO (International Organization for Standardization) Standard 13256-1 and provide among the highest ratings in the industry, exceeding

ASHRAE (American Society of Heating, Refrigerating and Air-Conditioning Engineers) 90.1 Energy Standards.

High quality construction and testing

All units are manufactured to meet extensive quality control protocol from start to finish through an automated control system, which provides continuous monitoring of each unit and performs quality control checks as equipment progresses through the production process. Standard construction features of the Aquazone™ units include:

Cabinet

Standard unit fabrication consists of heavy gage galvanized sheet metal cabinet construction designed for part standardization (i.e., minimal number of parts) and modular design.

All interior surfaces are lined with 1/2 in. thick, 1-1/2 lb per cubic ft density insulation for thermal insulation and acoustical attenuation. This insulation is non-combustible, non-hygroscopic and does not support fungal growth. Insulation meets NFPA90A and 90B for fire protection and is certified to meet the Greenguard Indoor Air Quality Standard for Low Emitting Products.

Protection against corrosion is a feature for this series. A stainless steel drain pan is designed to last the lifetime of the unit and resist corrosion and cracking that may occur with steel or plastic materials.

Compressor

Aquazone™ large capacity units include dual high capacity scroll compressors. Compressor isolation is specially selected for each compressor size.

Blower and motor assembly

Belt-driven centrifugal blowers are provided with all units to satisfy many air

distribution applications. Aquazone™ blower motors are designed to operate at lower temperatures to help improve the reliability of the WSHP.

Refrigeration/water circuit

Units have a sealed refrigerant circuit including a scroll compressor. Refrigerant circuits are provided with a standard thermostatic expansion valve (TXV) for higher accuracy and performance. Also standard are a reversing valve (4-way valve), water-to-refrigerant coaxial (tube-in-tube) coil, and enhanced aluminum fin/rifled copper tube air-to-refrigerant heat exchanger coil.

AHRI/ISO

Applicable Carrier Aquazone™ WSHP units have AHRI (Air-Conditioning, Heating and Refrigeration Institute)/ISO, NRTL (Nationally Recognized Testing Lab), or ETL (Engineering Testing Laboratory) labels and are factory tested under normal operating conditions at nominal water flow rates. Quality assurance is provided with testing report cards shipped with each unit to indicate specific unit performance under cooling and heating modes of operation.

Puron® refrigerant (R-410A)

Puron refrigerant (R-410A) is a non-chlorine based environmentally balanced, non-ozone depleting refrigerant. Puron refrigerant characteristics, compared to R-22, have:

- Binary and near azeotropic mixture of 50% R-32 and 50% R-125.
- Higher efficiencies (50 to 60% higher operating pressures).
- Virtually no glide. Unlike other alternative refrigerants, the two components in Puron refrigerant have virtually the same leak rates. Therefore, refrigerant can be added if necessary without recovering the charge.

Quiet operation

All panels are insulated with 1/2 in. thick, 1-1/2 lb per cubic ft dual-density fiberglass insulation for better thermal insulation and noise reduction.

Noise reduction is a critical consideration of the unit design. Even under normal operating conditions, vibration may be transmitted to the building structure and introduced into the space as noise. For vibration isolation, all compressors are mounted on rubber grommets. Compressor rubber isolators are necessary to prevent vibration transmission from the compressor to the unit cabinet and duct work. Vertical cabinets have an insulated divider panel between the blower compartment and the compressor section to minimize the

Table of contents

	Page
Features/Benefits	2
Model Number Nomenclature	4
AHRI/ISO Capacity Ratings	6
Physical Data	7
Options and Accessories	8
Dimensions	13
Performance Data	34
Electrical Data	36
Application Data	41
Control Sequence of Operation	46
Guide Specifications	51

Features/Benefits (cont)



transmission of compressor noise, and to permit operational service testing without air bypass.

Design flexibility

Aquazone™ units are available in four airflow patterns including top or front discharge with right or left return. Standard or extended water range options allow units to operate in a wide variety of applications. Water flow rates as low as 1.5 gpm per ton assist with selection from a various range of circulating pumps. Factory-installed options are offered to meet specific design requirements.

Safe, reliable operation

Standard safety features for the refrigerant circuit include high-pressure switch and low-pressure sensor to detect loss of refrigerant. A low air temperature sensor safeguards against freezing. Equipment safety features include water loop temperature monitoring, voltage protection, water coil freeze protection, and standard electronic condensate overflow shutdown. All Aquazone™ safety features are tested at the factory to assure proper operation of all components and safety switches.

All components are carefully designed and selected for endurance, durability, and carefree day-to-day operation.

The Aquazone™ unit is shipped to provide internal and external equipment protection. Shipping supports are placed under the blower housing and compressor feet. In addition, units are mounted on oversized pallets with lag bolts for sturdiness and maximum protection during transit.

Ease of installation

The Aquazone™ unit is packaged for simple low cost handling, with minimal time required for installation. All units are pre-wired and factory charged with refrigerant. Water connections (FPT) and condensate drains (FPT) are anchored securely to the unit cabinet. High and low voltage knockouts are provided on all units.

Simple maintenance and serviceability

The Aquazone™ WSHP units are constructed to provide ease of maintenance. Units have large removable panels for easy access. Additional panels are provided to access the blower and control box sections.

The blower housing assembly can be serviced without disconnecting ductwork from the dedicated blower access panel. Blower units are provided with

permanently lubricated bearings for worry-free performance.

Electrical disconnection of the blower motor and control box is easily accomplished from quick disconnects on each component.

Easy removal of the control box from the unit provides access to all refrigeration components.

The refrigeration circuit is easily tested and serviced through the use of high and low pressure ports integral to the refrigeration circuit.

Maximum control flexibility

Aquazone™ water source heat pumps are compatible with accessory Carrier or third party heat pump thermostats or Carrier Open or third party direct digital control DDC systems using the thermostat style inputs. Factory installed WSHP Open DDC control is also available.

All Aquazone™ WSHPs feature a factory installed Unit Protection Module (UPM). The UPM monitors the refrigerant circuit safeties and govern the operation of the compressor. The UPM also simplifies troubleshooting and through the included alarm output relay and LED fault indicator with blink code fault diagnostics. Additional features/functions of the UPM include:

Compressor contactor control

Compressor contactor control to enable/disable compressor operation.

Anti-short cycle timer

Anti-short cycle timer provides a minimum off time to prevent the unit from short cycling. The 5-minute timer energizes when the compressor is de-energized, resulting in a 5-minute delay before the unit can be restarted.

Random start relay

Random start relay provides a random delay in energizing each different WSHP unit. This option minimizes peak electrical demand during start-up from different operating modes or after building power outages. Each controller has a unique random start delay ranging from 270 to 300 seconds after power is applied to the board.

High and low pressure refrigerant protection

High and low pressure refrigerant protection safeguards against unreliable unit operation and prevents refrigerant from leaking.

Condensate overflow sensor

Condensate overflow sensor, mounted to the drain pan, recognizes 30 continuous

seconds of condensate pan overflow as a fault. When condensate pan liquid reaches an unacceptable level, unit is automatically deactivated and placed in a lockout condition.

High and low voltage protection

High and low voltage protection safe guards against excessive or low voltage conditions.

Automatic intelligent reset

Automatic intelligent reset automatically restarts the unit 5 minutes after shutdown, if the fault has cleared. Should a fault occur 2-4 times sequentially (field selectable), lockout will occur.

Alarm output

Alarm output is provided by the controller's set of contacts for remote fault indication. This can be either a steady output or can be set to pulse with the fault code. Two connections are available: one to provide a 24-volt output, the other to provide a dry contact.

Hard lockout reset

Hard lockout reset can be accomplished by turning the unit thermostat off and then back on, or by shutting off unit power at the circuit breaker. The method of reset is selectable by the DIP switch on the board.

Water coil freeze protection (selectable for water or antifreeze)

Water coil freeze protection (selectable for water or antifreeze) field selectable switch for water and water/glycol solution systems initiates a fault when temperatures exceed the selected limit for 30 continuous seconds.

Service test mode with diagnostic LED (light-emitting diode)

Service test mode with diagnostic LED (light-emitting diode) allows service personnel to check the operation of the WSHP and control system efficiently. Upon entering Test mode, time delays are sped up, and the Status LED will flash a code to indicate the last fault experienced for easy diagnosis. Based on the fault code flashed by the status LED, system diagnostics are assisted through the use of Carrier provided troubleshooting tables for easy reference to typical problems.

LED visual output

LED visual output indicates high pressure, low pressure, low voltage, high voltage, air/water freeze protection, condensate overflow, and control status on an LED panel.

Model number nomenclature – 50HQP



50HQP 072 N C C 5 B 1 A X

Aquazone™ Water Source Heat Pump with Puron® Refrigerant (R-410A)

50HQP – Horizontal Configuration

Size – Nominal Tons

072 – 6	150 – 12.5
096 – 8	180 – 15
120 – 10	242 – 20

Airflow Configuration

Option	Return	Discharge
J –	Right	Left (Straight) ^a
N –	Left	Right (Straight)
P –	Left	Back ^b

Control

- C – Standard Complete C Control Package
- D – Deluxe D Control Package
- W – WSHP Open Direct Digital Control

Refrigerant Circuit Options

- | | |
|--------------------------------------|--------------------------------------|
| A – Cu, Coated Air Coil (CAC) | T – Cu, HGB |
| B – Cu, Economizer | U – Cu, CAC, HGB |
| C – Cu | V – CuNi, CAC, HGR, HGB |
| D – Cu, CAC, HGR | W – CuNi, CAC, HGB |
| E – Cu, HGR | Y – Cu, Economizer, HGB |
| F – CuNi, CAC, HGR | Z – CuNi, Economizer, HGB |
| G – CuNi, Economizer | 1 – Econ, HGR, HGB |
| H – Cu, CAC, Economizer | 2 – CuNi, HGR, HGB, Econ |
| J – CuNi, CAC | 3 – Cu, CAC, HGR, HGB, Econ |
| K – CuNi, CAC, Economizer | 4 – CuNi, CAC, HGR, HGB, Econ |
| L – HGB, HGR | 5 – Cu, CAC, Econ, HGB |
| M – CuNi, HGR, HGB | 6 – CuNi, CAC, Econ, HGB |
| N – CuNi | 7 – Cu, Econ, HGR |
| P – CuNi, HGR | 8 – CuNi, Econ, HGR |
| Q – CuNi, CAC, Econ, HGR | 9 – Cu, CAC, Econ, HGR |
| R – Cu, CAC, HGR, HGB | |
| S – CuNi, HGB | |

Blower Drive Options

- A – 2 HP Belt Drive with VFD (208-230/3/60)
- B – 2 HP Belt Drive
- C – 3 HP Belt Drive
- E – 5 HP Belt Drive with VFD (208-230/3/60)
- K – 3 HP Belt Drive with VFD (208-230/3/60)
- M – 5 HP Belt Drive with VFD for SAV
- N – 3 HP Belt Drive with VFD (460/3/60)
- P – 2 HP Belt Drive with VFD for SAV
- R – 5 HP Belt Drive
- S – 2 HP Belt Drive with VFD (460/3/60)
- V – 3 HP Belt Drive with VFD for SAV
- X – 1 HP Belt Drive
- Y – 5 HP Belt Drive with VFD (460/3/60)
- Z – 1.5 HP Belt Drive

Operating Range, IEQ, IAQ

- A – Extended Range (20 to 110°F)
- D – Extended Range, 1/2-In. Closed Cell Foam
- F – Extended Range, Mute Pkg., 1/2-In. Closed Cell Foam
- J – Extended Range, Mute Pkg.
- T – Extended Range (20 to 110°F), 2 In. Filter Rack
- U – Extended Range, Mute Pkg., 2 In. Filter Rack
- X – Extended Range, 1/2-In. Closed Cell Foam, 2 In. Filter Rack
- Y – Extended Range, Mute Pkg., 1/2-In. Closed Cell Foam, 2 In. Filter Rack

Additional Options

- 1 – None
- A – Cooling Only

Revision Code

- A – Current Revision (120-242)
- B – Current Revision (072-096)

Voltage

- 1 – 575-3-60
- 3 – 208/230-1-60
- 5 – 208/230-3-60
- 6 – 460-3-60

LEGEND

- Cu** – Copper
- CuNi** – Cupronickel
- HGB** – Hot Gas Bypass
- HGR** – Hot Gas Reheat
- IAQ** – Indoor Air Quality
- IEQ** – Indoor Environmental Quality
- CAC** – Coated Air Coil

NOTES:

- a. Available sizes 180 and 242 only.
- b. Available sizes 072 and 096 only.

Model number nomenclature – 50VQP



50VQP 072 B C C 3 B 1 C X

Aquazone™ Water Source Heat Pump with Puron® Refrigerant (R-410A)

50VQP – Vertical Configuration

Size – Nominal Tons

072 – 6	151 – 12.5	240 – 20
096 – 8	181 – 15	300 – 25
120 – 10	210 – 17.5	360 – 30

Airflow Configuration

Option	Standard	180 Deg. Rotation ^a	
		Blower	Blower + Motor
Rear Return/Top Discharge	B	C	D
Front Return/Top Discharge	F	G	H
Rear Return/Front Discharge	S	-	-
Front Return/Rear Discharge	Z	-	-

Control

C – Standard Complete C Control Package
 D – Deluxe D Control Package^a
 W – WSHP Open Multi-Protocol Controller

Refrigerant Circuit Options

Option	Non-Coated Air		Coated Air	
	Cu Water	CuNi Water	Cu Water	CuNi Water
None	C	N	A	J
Hot Gas Reheat (HGRH)	E	P	D	F
Hot Gas Bypass (HGBP)	T	S	U	W
Water Side Economizer (WSE) ^c	B	G	H	K
HGRH + HGBP	L	M	R	V
HGRH + WSE ^c	7	8	9	Q
HGBP + WSE ^c	Y	Z	5	6
HGRH + HGBP + WSE ^c	1	2	3	4

LEGEND

Cu – Copper
CuNi – Cupronickel
HGB – Hot Gas Bypass
HGR – Hot Gas Reheat
IAQ – Indoor Air Quality
IEQ – Indoor Environmental Quality

NOTES:

- Deluxe D control package is not available for units with selected Cooling only option (option A position 14).
- Deluxe D control package is not available for units with selected Cooling only option (option A position 14).
- Units with selected Water Side Economizer come with 2 sided filter rack.

Blower Drive Options

Option	Motor HP				
	1	1.5	2	3	5
Standard Belt Drive	X	Z	B	C	R
Belt Drive w/ VFD 208-230V	-	-	A	K	E
Belt Drive w/ VFD 460V	-	-	S	N	Y
Belt Drive w/ VFD for SAV	-	-	P	V	M

Operating Range, IEQ, IAQ

Option	Std. Range (50 to 100°F)	Ext. Range (25 to 110°F)
None	C	A
4-Sided 2" Filter Rack (FR)	R	T
Mute Package (MP)	N	J
Closed Cell Foam (CCF)	E	D
Take Apart Construction (TAC)	G	B
FR + MP	S	U
FR + CCF	V	X
FR + TAC	1	3
FR + MP + CCF	W	Y
FR + MP + TAC	2	4
FR + MP + CCF + TAC	6	8
FR + CCF + TAC	5	7
MP + CCF	P	F
MP + TAC	Q	M
MP + CCF + TAC	Z	L
CCF + TAC	K	H

Additional Options

1 – None
 A – Cooling Only

Revision Code

A – Current Revision (120-360)
 B – Current Revision (072-096)

Voltage

1 – 575-3-60
 3 – 208/230-1-60
 5 – 208/230-3-60
 6 – 460-3-60

50HQP and 50VQP Unit Capacity Ratings

50HQP, VQP UNIT SIZE	FLUID FLOW RATE gpm	WATER LOOP HEAT PUMP				GROUND WATER HEAT PUMP				GROUND LOOP HEAT PUMP			
		Cooling 86°F		Heating 68°F		Cooling 59°F		Heating 50°F		Cooling 77°F		Heating 32°F	
		Capacity Btuh	EER	Capacity Btuh	COP	Capacity Btuh	EER	Capacity Btuh	COP	Capacity Btuh	EER	Capacity Btuh	COP
072	16.0	72,900	13.9	79,500	4.75	82,200	20.2	67,000	4.2	76,500	16.1	53,800	3.5
096	21.0	93,300	13.1	114,800	4.85	106,500	21.3	94,700	4.3	98,000	15.6	75,100	3.5
120	28.0	124,000	13.2	158,000	4.40	134,000	18.3	123,000	3.9	127,200	14.7	100,000	3.2
150	35.0	157,000	16.0	181,000	5.60	185,000	24.0	140,000	5.0	166,000	17.9	107,000	4.2
151	35.0	147,000	16.0	181,000	5.60	175,000	24.0	140,000	5.0	155,000	17.9	107,000	4.2
180	42.0	182,000	14.2	204,000	5.00	195,000	20.0	156,000	4.2	185,000	15.4	118,000	3.5
181	42.0	170,000	14.2	204,000	5.00	185,000	20.0	156,000	4.2	175,000	15.4	118,000	3.5
210	50.0	220,000	14.6	270,000	5.10	292,000	22.5	204,000	4.5	250,000	17.2	152,000	3.9
240	60.0	248,000	14.4	315,000	5.00	310,000	21.1	250,000	4.5	275,000	16.0	180,000	3.9
242	60.0	248,000	14.4	315,000	5.00	310,000	21.1	250,000	4.5	275,000	16.0	180,000	3.9
300	75.0	295,000	13.0	376,000	4.20	365,000	18.8	300,000	3.8	318,000	14.0	222,000	3.2
360	90.0	386,000	14.8	435,000	4.20	472,000	22.0	342,000	4.0	412,000	16.4	252,000	3.3

LEGEND

- AHRI — Air-Conditioning, Heating and Refrigeration Institute
- COP — Coefficient of Performance
- db — Dry Bulb
- EER — Energy Efficiency Ratio
- ISO — International Organization for Standardization
- wb — Wet Bulb

NOTES:

1. All units are rated in accordance with AHRI/ISO 13256-1.
2. Sizes 072-120 are certified in accordance with AHRI/ISO 13256-1.



Sizes 072-120 only



50HQP and 50VQP Unit Physical Data

50HQP,VQP UNIT SIZE		072	096	120	150	151	180
Compressor Type		Scroll	Scroll	Scroll	Scroll	Scroll	Scroll
Quantity		2	2	2	2	2	2
Total Refrigerant Charge (lb) Vert/Horiz		9.88/9.13	10/11.25	12.38	14	13.38	15.88
Air Coil Dimensions (in.) H x L (Qty)		20 x 32.5 (2)	20 x 32.5 (2)	20 x 32.5 (2)	24 x 65 (1)	24 x 43 (2)	24 x 65 (1)
Rows		3	3	3	3	3	3
Horizontal Filter Size (in.) (Nominal) (Qty)		20 x 34-1/2 x 1 (2)	20 x 34-1/2 x 1 (2)	20 x 34-1/2 x 1 (2)	24 x 34 x 1 (2)	N/A	24 x 34 x 1 (2)
Vertical Filter Size (in.) (Nominal) (Qty)		20 x 34-1/2 x 1 (2)	20 x 34-1/2 x 1 (2)	20 x 34-1/2 x 1 (2)	N/A	24 x 24 x 1 (4)	N/A
Blower Wheel Size (in.) (Dia. x W) (Qty)		12 x 12 (1)	12 x 12 (1)	H: 12 x 9 (2) V: 15 x 15 (1)	15 x 15 (1)	15 x 15 (1)	12 x 12 (2)
Fan Allowable Max. (rpm)		1800	1800	H: 1800 V: 1600	1600	1600	1600
Std. Motor HP (Qty)	Horizontal	1 (1)	2 (1)	3 (1)	3 (1)	N/A	2 (2)
	Vertical	1 (1)	1-1/2 (1)	2 (1)	NA	3 (1)	N/A
Type		Ball Bearing	Ball Bearing	Ball Bearing	Ball Bearing	Ball Bearing	Ball Bearing
Horizontal Water Connections (in.) FPT		1	1	1-1/4	1-1/2	N/A	1-1/2
Vertical Water Connections (in.) FPT		1	1	1-1/2	N/A	1-1/2	N/A
Water Coil Type		Coaxial	Coaxial	Coaxial	Coaxial	Coaxial	Coaxial
Coil Volume (gal)		0.64	0.64	0.87	1.06	1.06	1.06
Rated Water Flow Rate (gpm)		14.0	18.0	24.0	30.0	30.0	32.0
Water Pressure Drop at Rated Flow (psig) and (ft. hd) Water Loop Cooling		4.8/11.0	5.1/11.7	4.3/10.0	3.0/7.0	3.0/7.0	3.4/7.9
Horizontal Condensate Connection (in.) FPT		3/4	3/4	3/4	3/4	N/A	1-1/4
Vertical Condensate Connection (in.) FPT		3/4	3/4	3/4	N/A	3/4	N/A
Unit Ship Weight (Vert/Horiz) (lb)		715/715	752/752	980/980	N/A/1150	1140/N/A	N/A/1620
Unit Operating Weight (Vert/Horiz) (lb)		670/670	702/702	935/935	N/A/1060	1050/N/A	N/A/1530

50HQP,VQP UNIT SIZE		181	210	240	242	300	360
Compressor Type		Scroll	Scroll	Scroll	Scroll	Scroll	Scroll
Quantity		2	2	2	2	2	2
Total Refrigerant Charge (lb)		15.25	16.25	18.13	18.13	18.13	36.00
Air Coil Dimensions (in.) H x L (Qty)		24 x 43 (2)	20 x 32.5 (4)	20 x 32.5 (4)	34 x 65 (1)	20 x 32.5 (4)	30 x 32.5 (2)
Rows		3	3	3	3	3	3
Horizontal Filter Size (in.) (Nominal) (Qty)		N/A	N/A	N/A	17-1/4 x 34-1/2 x 1 (4)	N/A	N/A
Vertical Filter Size (in.) (Nominal) (Qty)		24 x 24 x 1 (4)	20 x 34-1/2 x 1 (4)	20 x 34-1/2 x 1 (4)	N/A	20 x 34-1/2 x 1 (4)	30 x 34-1/2 x 1 (4)
Blower Wheel Size (in.) (Dia. x W) (Qty)		15 x 15 (1)	15 x 15 (2)	15 x 15 (2)	15 x 15 (2)	15 x 15 (2)	15 x 15 (2)
Fan Allowable Max. (rpm)		1600	1600	1600	1600	1600	1600
Std. Motor HP (Qty)	Horizontal	N/A	N/A	N/A	2 (2)	N/A	N/A
	Vertical	5 (1)	1-1/2 (2)	2 (2)	N/A	3 (2)	5 (2)
Type		Ball Bearing	Ball Bearing	Ball Bearing	Ball Bearing	Ball Bearing	Ball Bearing
Horizontal Water Connections (in.)FPT		N/A	N/A	N/A	2	N/A	N/A
Vertical Water Connections (in.) FPT		1-1/2	2	2	N/A	2	2
Water Coil Type		Coaxial	Coaxial	Coaxial	Coaxial	Coaxial	Coaxial
Coil Volume (gal)		1.06	3.04	3.40	3.40	3.40	3.31
Rated Water Flow Rate (gpm)		32.0	50.0	50.0	50.0	60.0	80.0
Water Pressure Drop at Rated Flow (psig) and (ft. hd) Water Loop Cooling		3.4/7.9	6.4/14.8	4.0/9.3	4.0/9.3	5.5/12.8	8.6/19.8
Condensate Connection (in.) FPT		3/4	1-1/4	1-1/4	1-1/4	1-1/4	1-1/4
Unit Ship Weight (Vert/Horiz) (lb)		1180/N/A	1180/N/A	1400/N/A	N/A/1755	1630/N/A	1750/N/A
Unit Operating Weight (Vert/Horiz) (lb)		1090/N/A	1090/N/A	1310/N/A	N/A/1655	1530/N/A	1650/N/A

ITEM	FACTORY-INSTALLED OPTION	FIELD-INSTALLED ACCESSORY
Air Coil Protection (Coated Air Coil)	X	
Waterside Economizer	X	
Cupronickel Heat Exchanger	X	
Sound Attenuation Packages	X	
Extended Range	X	
Motor HP Upgrade	X	
Deluxe D Control Package	X	
WSHP Open Multi-Protocol Controller	X	
Hot Gas Reheat	X	
Hot Gas Bypass	X	
WSHP Open ZS Sensor		X
WSHP Open Equipment Touch™ Device		X
WSHP Open System Touch™ Device		X
Carrier Non-Communicating Thermostat		X
Ball Valves		X
Y Strainers		X
Motorized Water Control Valve (2-way solenoid valve)		X
Hose Kit Assemblies		X
Electric Duct Heaters		X
50VQP 1 Speed VFD	X	
50HQP 1 Speed VFD		X
50VQP 2 Speed SAV VFD	X	
50HQP 2 Speed SAV VFD		X
2 in. 4-Sided Filter Rack	X	
Blower Orientation	X	

Factory-installed options

Waterside economizer is available for applications that require free cooling operation or require an economizer for code compliance. Waterside economizer provides the capability to use cold loop water to provide space cooling, which can reduce compressor operating hours and save energy.

The waterside economizer package is factory installed and includes a water to air coil, a coil drain pan, insulated water piping and inlet water connection, and three-way economizer control valve.

For units with Complete C or Deluxe D control, the economizer control package also includes a factory wired aquastat with remote sensing bulb for field installation on the water piping. When the entering water temperature drops below the aquastat set point (20°F to 60°F, adjustable), loop water is directed by the three-way valve to the economizer coil to cool the air entering the unit. The water leaving the economizer coil then passes through the coaxial coil, the compressor and reversing valve are disabled. When the loop temperature rises above the aquastat set point, the loop water is directed only to the coaxial coil and compressor is enabled.

For units with WSHP Open controls, the economizer control valve is controlled by the WSHP Open controller based on entering water temperature. When the entering water temperature is 5°F or more below the space temperature,

WSHP Open will activate the waterside economizer to precool the air entering the unit. WSHP Open will enable mechanical cooling if free cooling is not enough to condition the space load.

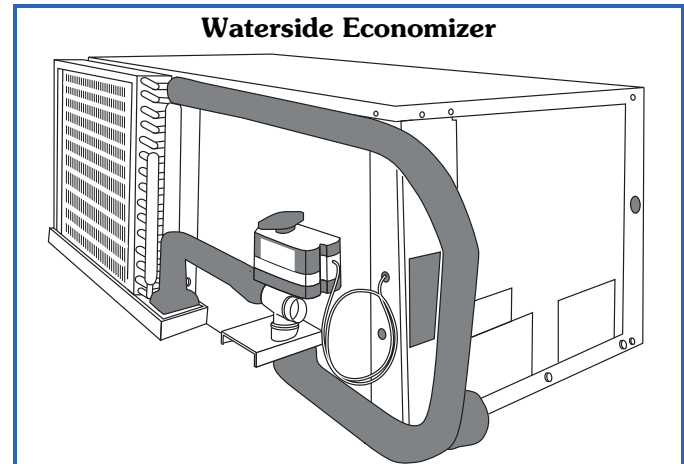

In addition to free cooling, WSHP Open can also use the waterside economizer for free heating. When the entering loop temperature is 5°F or more above the space temperature, the waterside economizer coil is activated to preheat the air entering the unit. WSHP Open will enable mechanical heating if free heating isn't enough to handle the space load.

Air coil protection (coated air coil) is available with 2 layers of corrosion protection. All active copper heat transfer surface on the air coil are coated in a tin plating to resist all common forms of coil corrosion including formicary, salt water and galvanic corrosion.

Additionally, the aluminum fins are e-coated in a state of the art protective layer to provide a long service life in the harshest of environments, including sea coast installations. Protected coils exceed 1000 hours of ASTM B117 salt spray testing.

Cupronickel heat exchangers are available for higher corrosion protection for applications such as open tower, geothermal, etc. Consult the water quality guidelines for proper application and selection of this option.

Sound attenuation package (mute package and closed cell foam insulation) is available for applications that require especially low noise levels. The mute package includes a compressor sound blanket to attenuate compressor sound. Closed cell foam insulation is installed on all unit panels to attenuate the compressor and fan sound.

Extended range units feature an insulated coaxial coil to prevent condensation in applications where the entering water temperature is below 50°F. Units will have an operating range of 50 to 110°F in cooling mode and 25 to 80°F in heating mode when equipped with extended range package.

An optional (reverse) blower orientation is available for applications where the ductwork orientation is opposite of the standard unit fan discharge. The blower location remains the same (top or front). See dimensional drawings for details.

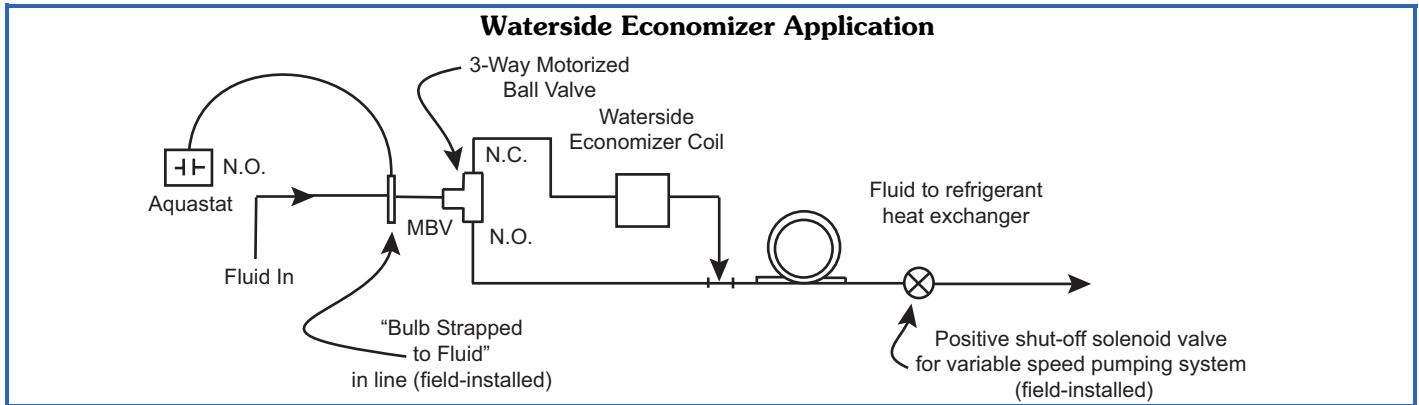

Complete C and Deluxe D Package Capabilities

CAPABILITY	COMPLETE C PACKAGE	DELUXE D PACKAGE
Unit Protection Module	X	X
High and Low Refrigerant Pressure Switches	X	X
Fluid Temperature (Freeze) Protection	X	X
Condensate Overflow Protection Sensor	X	X
Air Temperature (Freeze) Protection	X	X
Anti-Short Cycle Timer	X	X
Random Start Relay	X	X
Low Pressure Bypass Timer	X	X
Surge Protection	X	X
Intelligent Reset	X	X
Lockout Reset	X	X
Malfunction (Alarm) Output	X	X
Test Service Mode with LED Fault Indication	X	X
Dehumidification Control via Hot Gas Reheat	X	X
Waterside Economizer Control Capability	X	X
2-Stage Compressor Control	X	X
Field Installed DDC compatibility	X	X
Phase Monitor (3-phase units only)		X
Boilerless Heat Control		X
Energy Management Switch		X
Pump-Valve Relay		X

Complete C control package includes the UPM, thermostat style inputs, and a 75VA control circuit transformer.

Deluxe D control package provides all of the options on the standard Complete C control package in addition to the following:

- Phase Monitor — Prevent motors from running at temperatures above approved ratings, and provides protection against phase loss, phase reversal, and phase unbalance.
- Boilerless Heat Control — Includes an aquastat and 24V output to enable an external heat source. Used in applications where an external heat source is needed when the loop temperature drops heat pump heating capability.
- Energy Management Switch — Enables a 24 vac external signal to enable/disable the operation of the WSHP.
- Pump-Valve Relay — Provides a signal between an isolation valve and a secondary pump.

WSHP Open multi-protocol controller

Carrier's WSHP Open controller is an integrated component of a Carrier water source heat pump. The WSHP Open controller continuously monitors and regulates water source heat pump operation with reliability and precision. This advanced controller features a sophisticated, factory-engineered control

program that provides optimum performance and energy efficiency.

The WSHP Open controller is factory installed and programmed to control all factory-installed standard options including hot gas reheat and waterside economizer as well as provide boilerless electric heat control and demand controlled ventilation.

The WSHP Open controller is programmed to communicate amongst different protocols including BACnet™¹, N2, Modbus®¹ and LonWorks®¹. While the controller is programmed to operate on Carrier's i-Vu® building automation system (BAS), the WSHP Open can easily be integrated into a third party BAS.

NOTE: A separate LON integration card is required for LonWorks protocol.

Independent fan speed control

Independent fan speed control provides the most efficient WSHP operation. All WSHP Open controllers come programmed from the factory with independent fan control.

1. Third-party trademarks and logos are the property of their respective owners.

Using the space temperature input, the WSHP Open controller will automatically operate the fan at the lowest of up to 3 speeds to maintain space temperature while providing increased latent heat removal, reduced sound and the lowest fan energy consumption.

NOTE: Independent fan speed control is only available with belt drive motors when a VFD is ordered and installed with the WSHP.

Intuitive fault detection

Intuitive fault detection allows prolonged operation of the WSHP. The pre-programmed WSHP Open controller logic monitors and pre-emptively shuts down a WSHP as an alarming condition approaches instead of causing a hard lock out of the WSHP. This way, the WSHP can automatically restart if the fault condition clears within a set amount of time and a local reset of the WSHP is not required.

Learning Adaptive Optimal Start

Learning Adaptive Optimal Start transitions the WSHP from unoccupied set points to occupied set points in the most efficient means possible. Over time, the WSHP will learn and determine the best adjustment rates of the set points to provide the most efficient means of shifting the WSHP to an occupied mode.

Hot gas reheat (HGRH)

Hot gas reheat (HGRH) enables the unit to dehumidify the space without overcooling the space. This feature requires a separate thermostat with dehumidification output, humidistat, or DDC control with space relative humidity sensor and binary/digital output. The standard HGRH option is on/off HGRH. Modulating HGRH, for use with DDC controls, is available as a special order.

When the space temperature is satisfied but the space relative humidity is higher than the control set point, the unit cooling circuit and the HGRH circuit are activated. The HGRH circuit features a DX to air coil (HGRH coil) installed downstream of the evaporator coil. When enabled, the HGRH circuit directs hot refrigerant gas to the HGRH coil. After the air is dehumidified by the evaporator coil, it passes through HGRH coil, where it is warmed, to prevent overcooling the space. If at any time the space temperature is above the space temperature set point while the unit is in HGRH mode, HGRH mode is disabled and the unit will return to normal cooling mode. The hot gas reheat coil and reheat valve are factory installed and factory wired to the unit controller. For hot gas reheat performance data consult the WSHP Builder selection software.

Hot gas bypass (HGBP)

Hot gas bypass (HGBP) prevents frosting of the evaporator coil when the unit is operating at low load or low airflow conditions. This situation could arise if the space experiences widely different loads (for example, a conference center). Without a hot gas bypass circuit the evaporating temperature will fall and frost could form on the coil, restricting airflow and aggravating the situation. Eventually, the coil could be totally blocked, which prevents heat transfer and will result in the unit tripping on a low pressure fault.

The hot gas bypass valve located in the compressor discharge line diverts hot gas to the inlet of the air coil. The valve is factory set to open when the evaporator pressure falls to 75 psi and will modulate to prevent the pressure falling any lower. This setting is field adjustable and this set point may be adjusted as required.

1-Speed Supply Fan VFD

1-Speed Supply Fan VFD is available for applications that require a VFD for easy air balancing or for field control of the VFD, for filter loading. Units with WSHP Open can be field configured for 2 or 3 speed fan operation with the VFD. Units with the 1-speed VFD option also include an inverter duty motor.

NOTE: On 50VQP units, the VFD is factory wired and installed. On 50HQP units, the VFD does not fit in the cabinet and will ship loose for field installation. See supplemental VFD installation instructions.

Staged Air Volume (SAV) Supply Fan VFD

Staged Air Volume (SAV) Supply Fan VFD is available for applications that require a VFD for code compliance, providing two stages of fan control. The SAV option is a supply fan control arrangement that adjusts the fan speed based on the call for heating, cooling, or fan only. Units with the SAV VFD option also include an inverter duty motor.

NOTE: On 50VQP units, the VFD is factory wired and installed. On 50HQP units, the VFD does not fit in the cabinet and will ship loose for field installation. See supplemental VFD installation instructions.

2 in. filter rack

2 in. filter rack is an upgrade over the standard 1 in. 2 sided filter rack and allows for field installation of higher grade filters. The 2 in. filter rack is 4-sided and includes two fixed bottom rails and two side clips for tool-less removal for easy filter changes. Units with the 2 in. filter rack will ship with a 1 in. throwaway filter with a 1 in. filter spacer.

Take apart construction (TAC)

Take apart construction (TAC) is available for applications when the unit need to be split into two major pieces for ease of installation and rigging. Retrofit projects often utilize this feature since the units may have to be brought through existing doorways, down existing hallways, or even up elevators. Take apart construction consists of splitting the unit horizontally into two sections. A Condensing section (condenser/compressor) and an Air handler section (evaporator/fan) as shown on pages 32-33. Units ordered as take apart construction will ship as an assembled single piece with pre-cut interconnecting piping to be installed in the field. If units include a waterside economizer this will include pre-cut piping for the WSE as well. Each section will be factory charged with nitrogen. Refrigerant to be provided and charged in the field per the unit's data plate.

(For more detailed information, refer to the unit Installation Instructions.)

Options and accessories (cont)



Field-installed accessories

WSHP Open Equipment Touch™ and System Touch™

WSHP Open Equipment Touch and System Touch touch-screen devices have a color LCD display that allows easy connection to the controllers to view or change the controller's property values including set points, schedule equipment, view trends and alarms and more. The Equipment Touch device provides easy connection to one controller while the System Touch device can access up to 60 controllers when wired together as a network. For more details about the Equipment Touch and System Touch devices, see either the

Equipment Touch or System Touch Installation and Setup Guide.

WSHP Open - ZS sensors

Carrier's ZS sensors are the preferred method of monitoring space temperature, humidity and CO₂ levels when using the WSHP Open controller.

NOTE: The ZS sensor is required for space temperature with all WSHP Open controllers. Only a ZS sensor can provide the necessary space temperature input for the WSHP Open controller.

ZS Sensor Features

FEATURES	ZS STANDARD	ZS PLUS	ZS PRO	ZS PRO-F
Temp, CO ₂ , Humidity	X	X	X	X
Neutral Color	X	X	X	X
Addressable/Supports Daisy-Chaining	X	X	X	X
Hidden Communication Port	X	X	X	X
Mounts on a Standard 2-in. X 4-in. Electrical Box	X	X	X	X
Occupancy Status Indicator		X	X	X
Push-Button Occupancy Override		X	X	X
Set Point Adjust		X	X	X
Large, Easy-to-Read LCD			X	X
Alarm Indicator			X	X
Fan Speed Control				X
Cooling/Heating/Fan Only - Mode Control				X
F to C Conversion Button				X

ZS Sensor Options

OPTIONS	ZS STANDARD	ZS PLUS	ZS PRO	ZS PRO-F
	PART NUMBER			
Temperature Only	ZS-CAR	ZSPL-CAR	ZSP-CAR	ZSPF-CAR
Temperature with CO ₂	ZS-C-CAR	ZSPL-C-CAR	ZSP-C-CAR	ZSPF-C-CAR
Temperature with Humidity	ZS-H-CAR	ZSPL-H-CAR	ZSP-H-CAR	ZSPF-H-CAR
Temperature with Humidity and CO ₂	ZS-HC-CAR	ZSPL-HC-CAR	ZSP-HC-CAR	ZSPF-HC-CAR

Carrier Thermostat Options

THERMOSTAT TYPE	MODEL	DESCRIPTION
BACNET	Comfortvu BACnet Plus (TBPL-24-H-C / TBPL-24-HM-C)	<ol style="list-style-type: none"> 24 VAC controller with combination space temperature, relative humidity, and motion sensors (temperature, humidity only on TBPL-24-C). Large touch screen backlit display, 7-day scheduling, demand response, remote sensor capability, dry contact. BACnet MS/TP, 1-3 stage heat, 1-2 stage cool, 1-3 fan speeds, WSE, HGRH, HP.
	Comfortvu BACnet (TB-24-C / TB-24-HM-C)	
WIFI	Connect BACnet Wi-Fi (33CONNECTSTAT43)	<ol style="list-style-type: none"> 24 VAC controller with on-board space temperature and relative humidity sensor. Large touch screen LCD display, 7-day scheduling, demand response, remote sensor capability. BACnet MS/TP (33CONNECTSTAT43 only), up to 4 stage heat, up to 3 stage cool, WSE, HP.
	Connect Wi-Fi (33CONNECTSTAT)	
PROGRAMMABLE/ NON PROGRAMMABLE	Edge Pro (33CS2PP2S-03 / 33CS2PPRH-03)	<ol style="list-style-type: none"> 24 VAC programmable control with on-board temperature and humidity (temperature only on 33CS2PP2S-03). Backlit display 7-Day Programmable/Non-Programmable, 2-stage Heat/2-stage Cool, HP (with emergency heat). OR G/E, Dry Contact, Remote Sensor Capability, Pre-Occupancy Purge, Soft Start, Manual/Auto-Changeover, and Bypass Damper Output
	Comfort Pro (33CSCNACHP-01/ 33CSCPACHP-01)	

See Carrier Thermostat Product Data for further details.

Ball valves (brass body)

Ball valves (brass body) are used for shutoff and balancing water flow and are available with memory, memory stop, and pressure temperature ports. Valves consist of UL-listed brass body, ball and stem type with Teflon¹ seats and seals. Four sizes are available (1, 1-1/4, 1-1/2, 2 in.).

Y strainers (bronze body)

Y strainers (bronze body) are “Y” type strainers with a brass cap. With a maximum operating pressure rating of 450 psig, the strainer screen is made of stainless steel. Strainers are available with blow down valves. Four sizes are available (1, 1-1/4, 1-1/2, 2 in.).

Motorized Water Control Valve (2 way solenoid valve)

Motorized Water Control Valve (2 way solenoid valve) offered for applications involving open type systems or variable speed pumping. This valve will slowly open and close in conjunction with the compressor operation to shut off or turn on water to the unit. It is a slow-closing (ON/OFF) quiet operation with 24 vac, end switch and standard normally closed. Three sizes are available (1-1/4, 1-1/2, 2 in.).

Hose kit assemblies

Hose kit assemblies provide all the necessary components to hook up a water-side system. Supply hose includes a ported ball valve with pressure temperature (P/T) plug ports, flexible stainless steel hose with swivel and nipple. Return hose includes a ball valve, preset automatic balancing valve (gpm) with two P/T ports, flexible stainless steel hose with a swivel and nipple, balancing valve, and low-pressure drop water control valve.

Electric duct heaters

Electric duct heaters are available ranging from 5 to 20 kW of electric heat in all available WSHP voltages. These slip-in type heaters provide an extra means of auxiliary heat or reheat control.

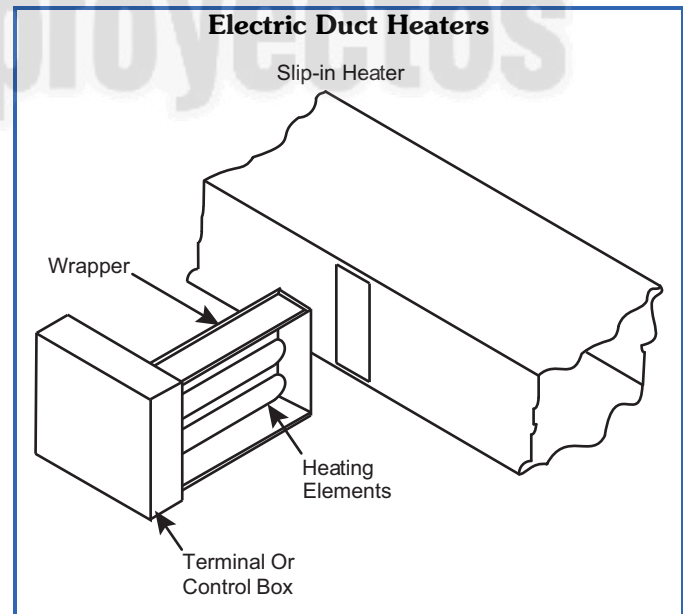

1. Third-party trademarks and logos are the property of their respective owners.

50HQP072-150 Units Horizontal Dimensions

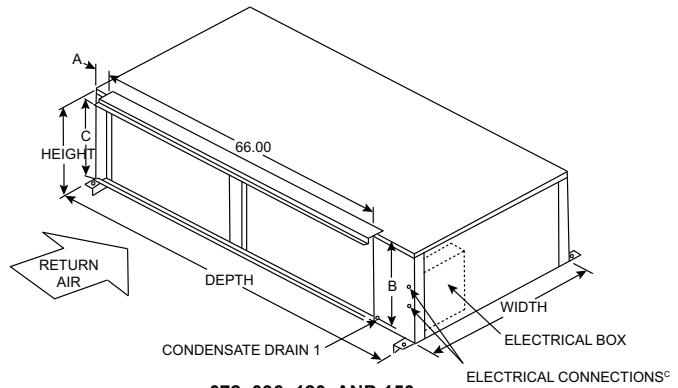
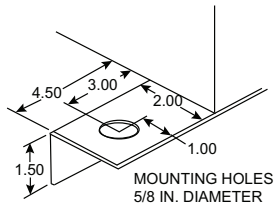

**072, 096, 120, AND 150
LEFT RETURN, RIGHT DISCHARGE**

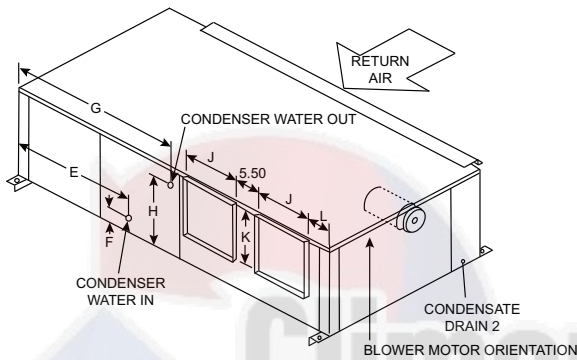

**120
LEFT RETURN, RIGHT DISCHARGE**

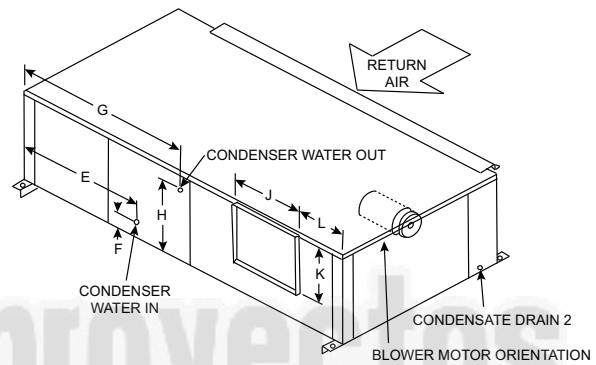

**072, 096, AND 150
LEFT RETURN, RIGHT DISCHARGE**

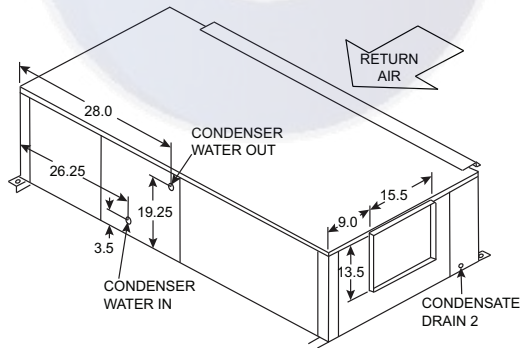

**072 AND 096
LEFT RETURN, BACK DISCHARGE**

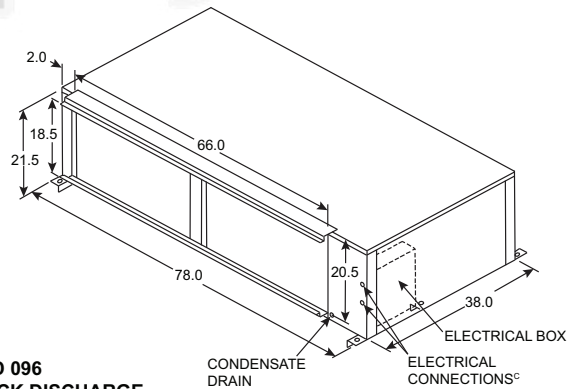

50HQP UNIT SIZE	HEIGHT ^a	WIDTH	DEPTH ^b	RETURN AIR			CONDENSER WATER CONNECTIONS					SUPPLY AIR (Blower Outlets)			REPLACEMENT FILTER SIZE (NOMINAL)
				A	B	C	E	F	G	H	DIAMETER (FPT)	J	K	L	
072	21.50	38.00	78.00	2.00	20.50	18.50	28.00	2.75	28.00	14.50	1	15.50	13.50	10.50	20 x 34-1/2 x 1 (2 per unit)
096	21.50	38.00	78.00	2.00	20.50	18.50	26.25	3.50	28.00	19.25	1	15.50	13.50	10.50	
120	21.50	38.00	78.00	2.00	20.50	18.50	27.50	3.38	28.00	16.75	1.25	12.50	13.50	5.25	
150	25.50	42.00	82.00	2.00	20.50	18.50	24.00	2.75	24.00	17.75	1.50	18.50	16.00	14.00	24 x 34 x 1 (2 per unit)

NOTE(S):

- All dimensions in inches unless otherwise noted. All dimensions within ± 0.125 -in. Specifications subject to change without notice. Condensate connections are 0.75 in. FPT on sizes 072-150.
- When WSHP Open controller is installed increase depth by 3.00 inches.
- Front of the unit is considered as the side with electrical box location.
- Distance from condensate drain center line to the bottom of the unit is 1-1/4 inches.

50HQ180-242 Units Horizontal Dimensions

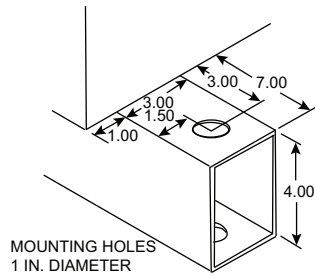

MOUNTING BRACKET
SECTION VIEW

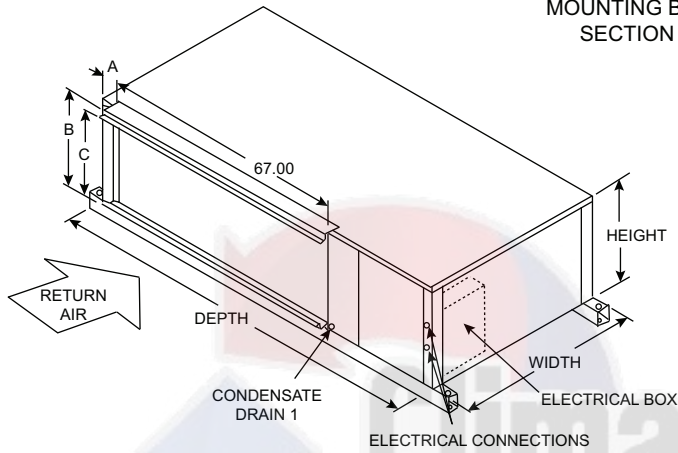

LEFT RETURN, RIGHT DISCHARGE

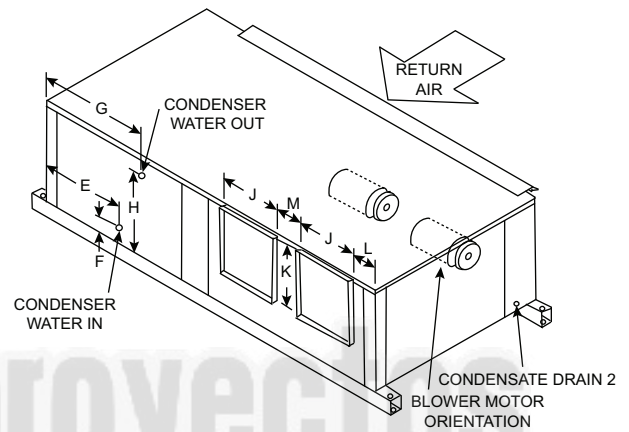

LEFT RETURN, RIGHT DISCHARGE

50HQ UNIT SIZE	HEIGHT ^a	WIDTH	DEPTH ^b	RETURN AIR			CONDENSER WATER CONNECTIONS					SUPPLY AIR (Blower Outlets)				REPLACEMENT FILTER SIZE (NOMINAL)
				A	B	C	E	F	G	H	DIAMETER (FPT)	J	K	L	M	
180	25.25	60.25	106.50	2.00	24.00	22.00	22.00	6.25	22.00	16.00	1.5	27.75	17.25	5.00	4.00	24 x 34 x 1 (2 per unit)
242	36.00	60.25	106.50	2.00	34.75	32.75	24.50	7.25	24.50	19.62	2.0	23.75	19.75	7.75	9.75	17-1/4 x 34-1/2 x 1 (4 per unit)

NOTE(S):

- All dimensions in inches unless otherwise noted. All dimensions within ± 0.125 -in. Specifications subject to change without notice. Condensate connections are 1.25 in. FPT on sizes 180 and 242.
- When WSHP Open controller is installed increase depth by 3.00 inches.
- Front of the unit is considered as the side with electrical box location.
- Distance from condensate drain center line to the bottom of the unit is 1-1/4 inches.

50VQP072-120 Units (Single Blower Large Commercial-Vertical Dimensions)

FRONT RETURN

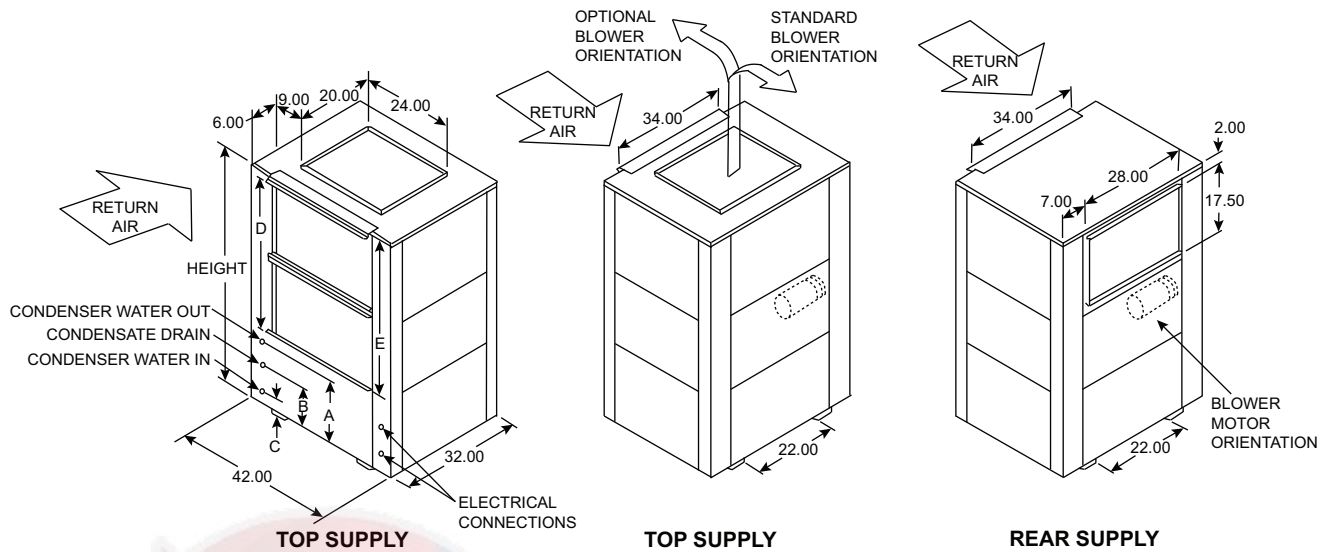

REAR RETURN

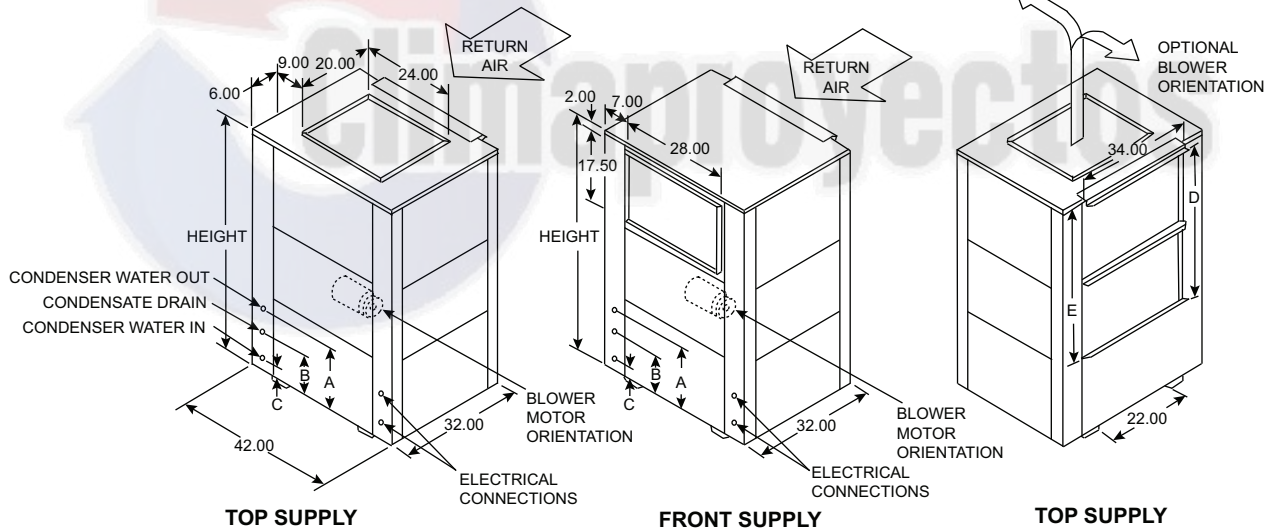

50VQP UNIT SIZE	HEIGHT ^a	WIDTH	DEPTH ^b	CONDENSER WATER CONNECTIONS ^c				DUCT FLANGE D	FILTER RACK E	REPLACEMENT FILTER SIZE (NOMINAL)
				A	B	C	Diameter (FPT)			
072	62.00	42.00	32.00	14.75	8.50	2.75	1	38.00	40.00	20 x 34-1/2 x 1 (2)
096	62.00	42.00	32.00	14.75	8.50	2.75	1			
120	62.00	42.00	32.00	15.00	9.00	3.00	1-1/2			

NOTE(S):

- a. All dimensions in inches unless otherwise noted. All dimensions within ± 0.125 -in. Specifications subject to change without notice. Condensate connections are 0.75 in. FPT on sizes 072-120.
- b. When WSHP Open controller is installed increase depth by 3.00 inches.
- c. Front of unit is side with water and electrical connections.

50VQP151-181 Units (Single Blower Large Commercial-Vertical Dimensions)

FRONT RETURN

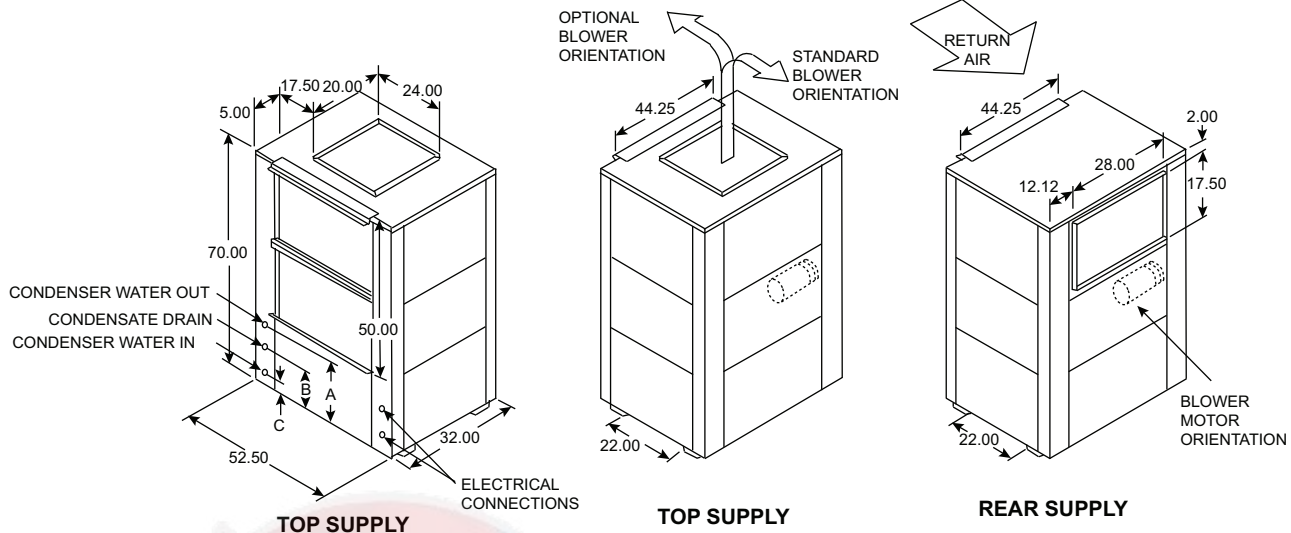

REAR RETURN

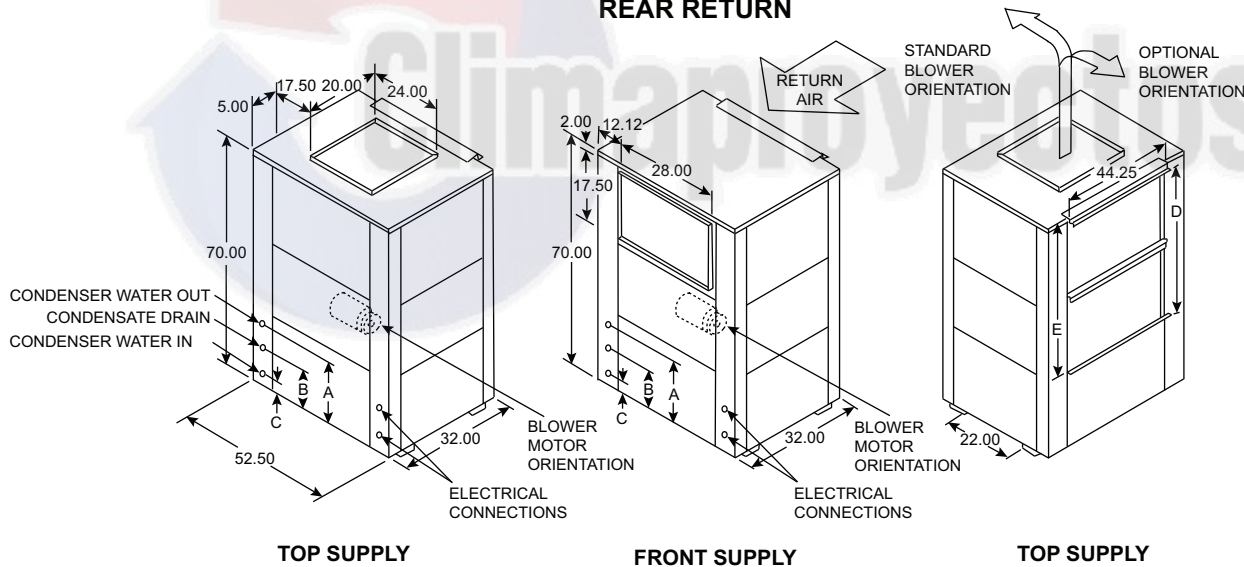

50VQP UNIT SIZE	HEIGHT ^a	WIDTH	DEPTH ^b	CONDENSER WATER CONNECTIONS ^c				DUCT FLANGE D	FILTER RACK E	REPLACEMENT FILTER SIZE (NOMINAL)
				A	B	C	Diameter (FPT)			
151	70.00	52.50	32.00	17.00	10.50	3.00	1-1/2	48.00	50.00	24 x 24 x 1 (4 per unit)
181	70.00	52.50	32.00	17.00	10.50	3.00	1-1/2	48.00	50.00	24 x 24 x 1 (4 per unit)

NOTE(S):

- All dimensions in inches unless otherwise noted. All dimensions within ± 0.125 -in. Specifications subject to change without notice. Condensate connections are 0.75 in. FPT on sizes 151 and 181.
- When WSHP Open controller is installed increase depth by 3.00 inches.
- Front of unit is side with water and electrical connections.

50VQP210-360 Units (Dual Blower Large Commercial-Vertical Dimensions)

FRONT RETURN

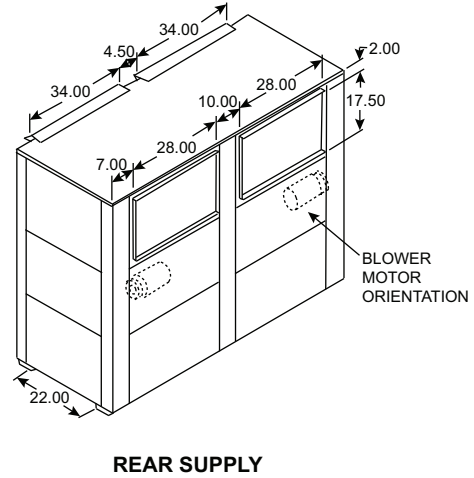
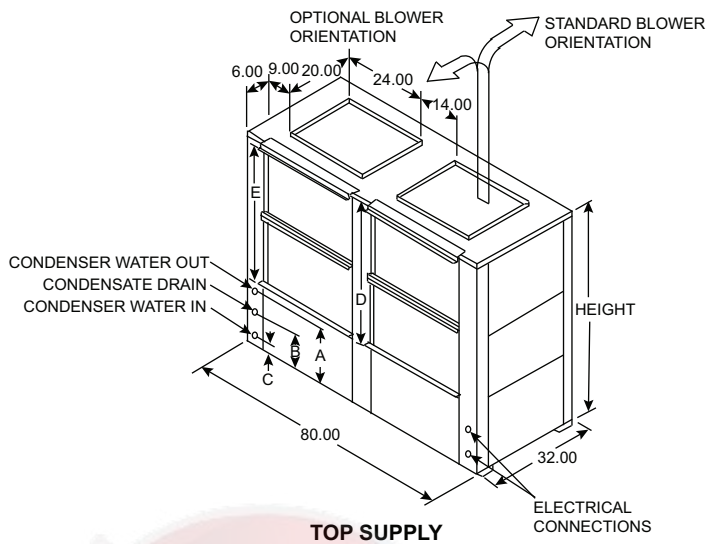

REAR RETURN

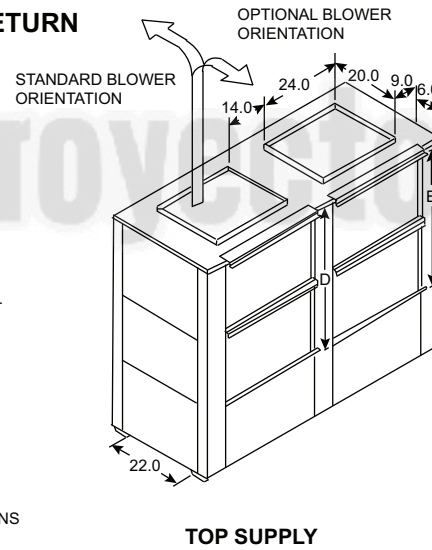
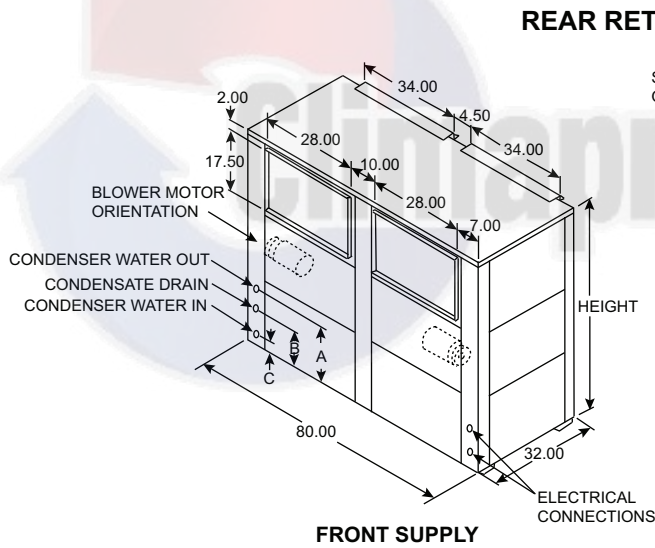

50VQP UNIT SIZE	HEIGHT ^a	WIDTH	DEPTH ^b	CONDENSER WATER CONNECTIONS ^c				DUCT FLANGE	FILTER RACK	REPLACEMENT FILTER SIZE (NOMINAL)
				A	B	C	Diameter (FPT)	D	E	
210	62.00	80.00	32.00	18.00	8.75	2.75	2	40.00	38.00	20 x 34-1/2 x 1 (4 per unit)
240	66.50	80.00	32.00	18.00	8.75	2.75	2	40.00	38.00	
300	66.50	80.00	32.00	18.00	8.75	2.75	2	40.00	38.00	
360	86.50	80.00	32.00	17.00	9.00	3.50	2	60.00	58.00	30 x 34-1/2 x 1 (4 per unit, size 360 only)

NOTE(S):

- a. All dimensions in inches unless otherwise noted. All dimensions within ± 0.125 -in. Specifications subject to change without notice. Condensate connections are 1.25 in. FPT on sizes 210-360.
- b. When WSHIP Open controller is installed increase depth by 3.00 inches.
- c. Front of unit is side with water and electrical connections.

50HQP072-120 Units with Economizer

LEFT HAND RETURN
RIGHT DISCHARGE

TOP VIEW

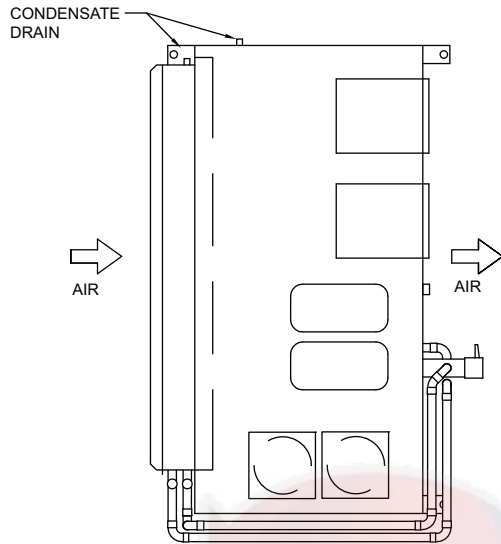

FRONT VIEW

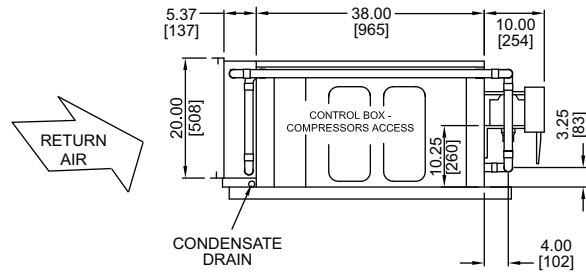

LEFT SIDE VIEW
(RETURN AIR)

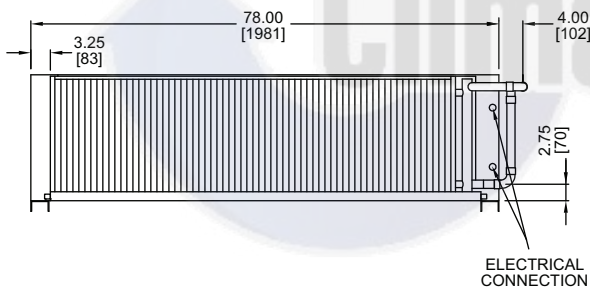

RIGHT SIDE VIEW

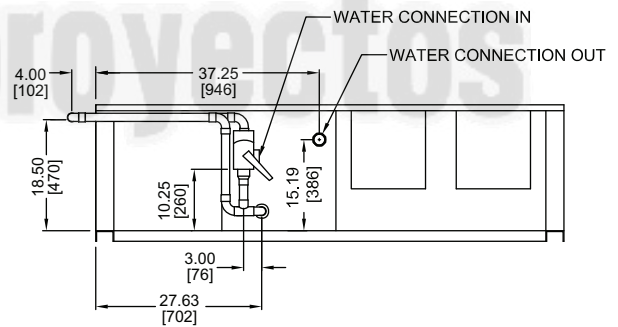

50HQP UNIT SIZE	072	096	120
FILTER QTY & SIZE	(2) 20" x 34-1/2" x 1"	(2) 20" x 34-1/2" x 1"	(2) 20" x 34-1/2" x 1"
CONDENSATE DRAIN	3/4" FPT	3/4" FPT	3/4" FPT
WATER CONN. OUT	1" FPT	1" FPT	1-1/4" FPT
WATER CONN. IN	2" FPT	2" FPT	2" FPT

NOTES:

1. Dimensions in inches [mm].
2. Units with two supply fan blowers require a pair of pants discharge duct.

50HQ150 Units with Economizer

LEFT RETURN
RIGHT DISCHARGE

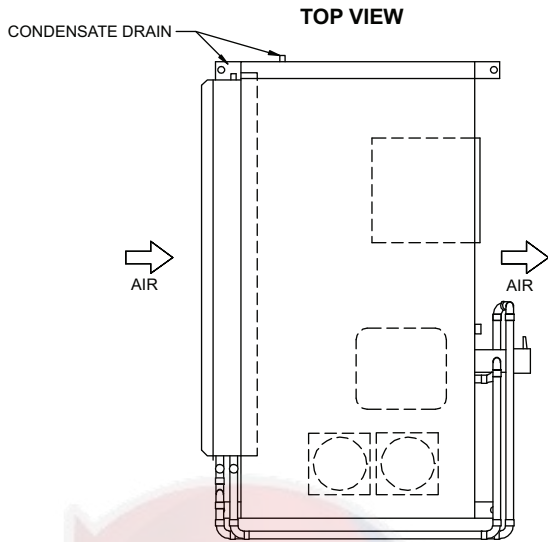

FRONT VIEW

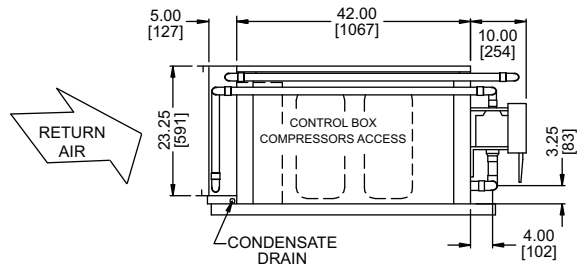

LEFT SIDE VIEW
(RETURN AIR)

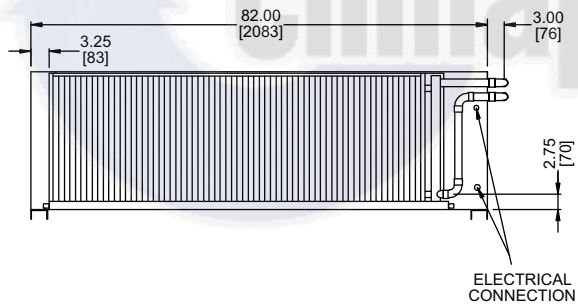

RIGHT SIDE VIEW

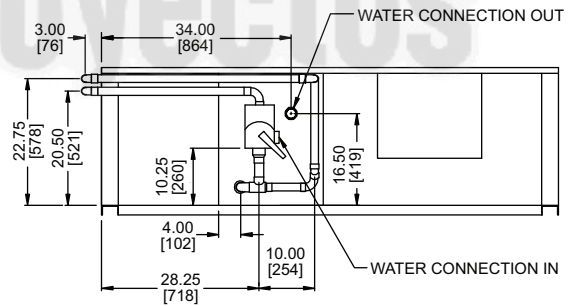

FILTER QTY & SIZE	(2) 24" x 34"x 1"
CONDENSATE DRAIN	3/4" FPT
WATER CONN. OUT	1-1/2" FPT
WATER CONN. IN	2" FPT

NOTE: Dimensions in inches [mm].

50HQP180 Units with Economizer

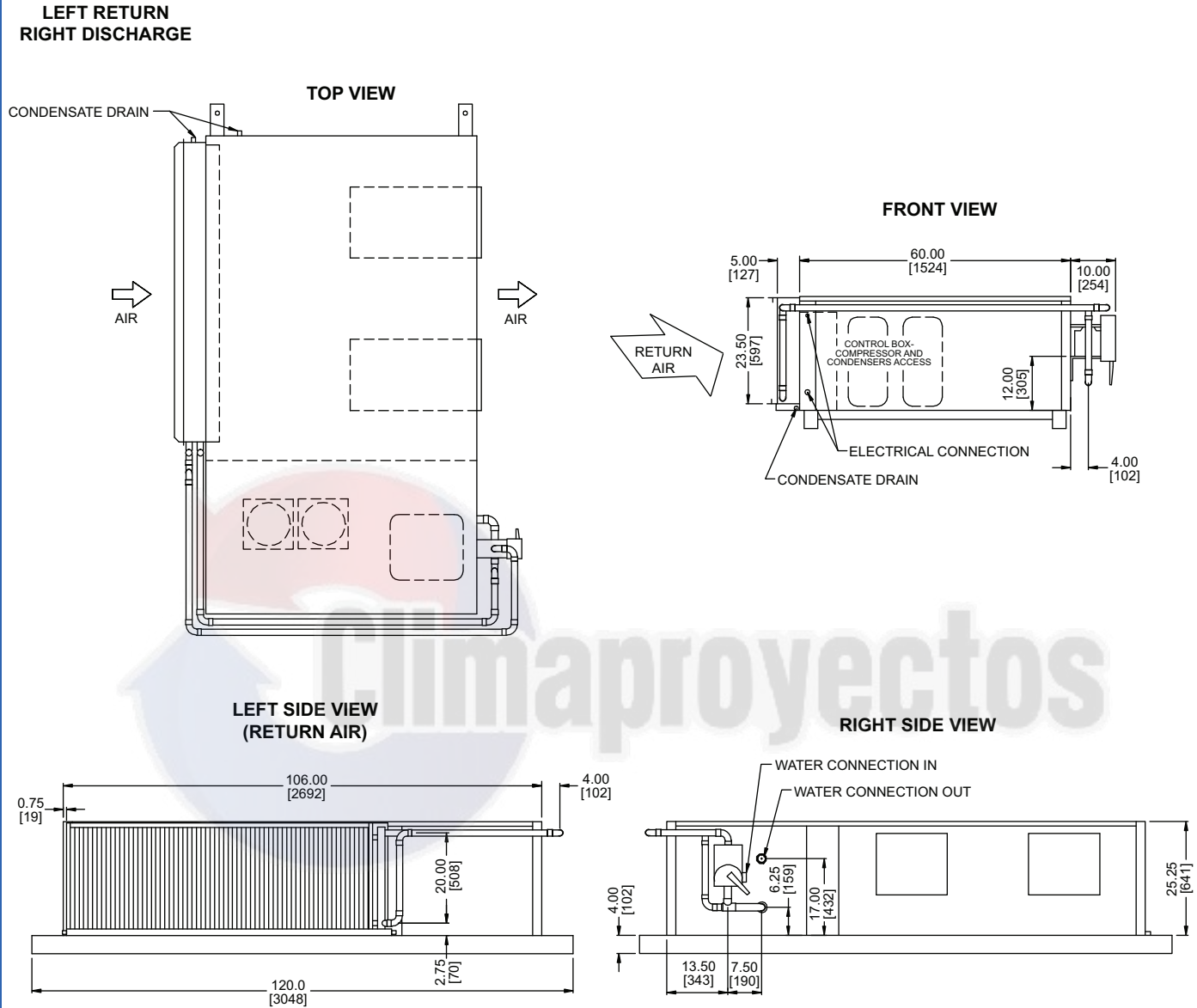

FILTER QTY & SIZE	(2) 24" x 34" x 1"
CONDENSATE DRAIN	1-1/4" FPT
WATER CONN. OUT	1-1/2" FPT
WATER CONN. IN	2" FPT

- NOTES:
1. Dimensions in inches [mm].
 2. Units with two supply outlets require a pair of pants duct connection.

50HQP242 Units with Economizer

LEFT RETURN
RIGHT DISCHARGE

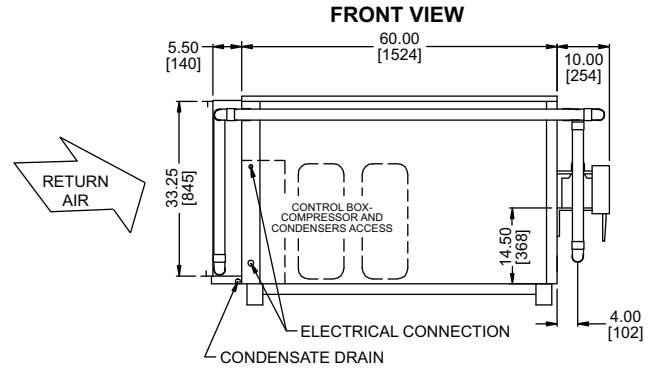
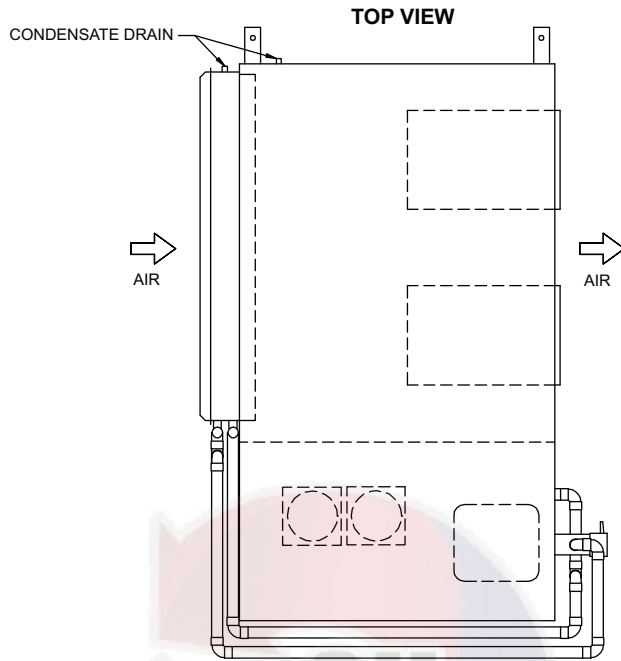

LEFT SIDE VIEW
(RETURN AIR)

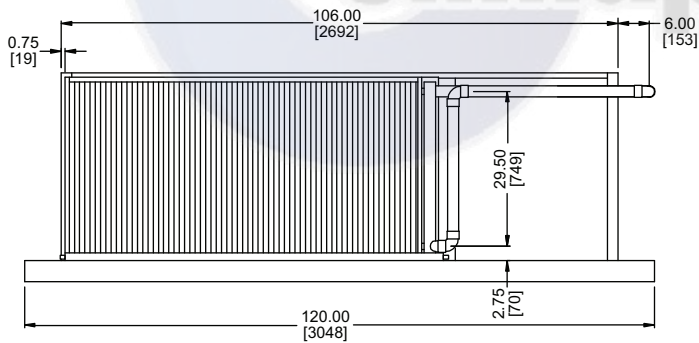

RIGHT SIDE VIEW

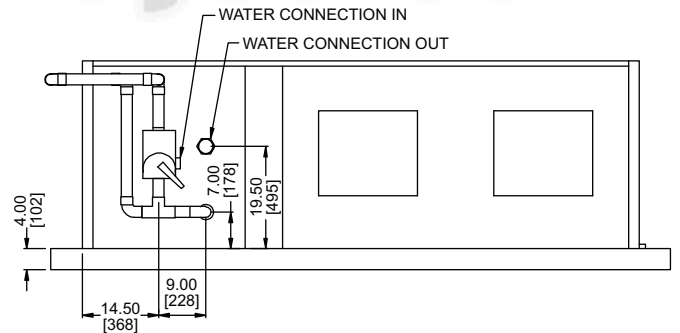

FILTER QTY & SIZE	(4) 17-1/4" X 34-1/2" X 1"
CONDENSATE DRAIN	1-1/4" FPT
WATER CONN. OUT	2" FPT
WATER CONN. IN	2" FPT

NOTES:

1. Dimensions in inches [mm].
2. Units with two supply outlets require a pair of pants duct connection.

50HQP072-096 Units with Waterside Economizer

LEFT RETURN
BACK DISCHARGE

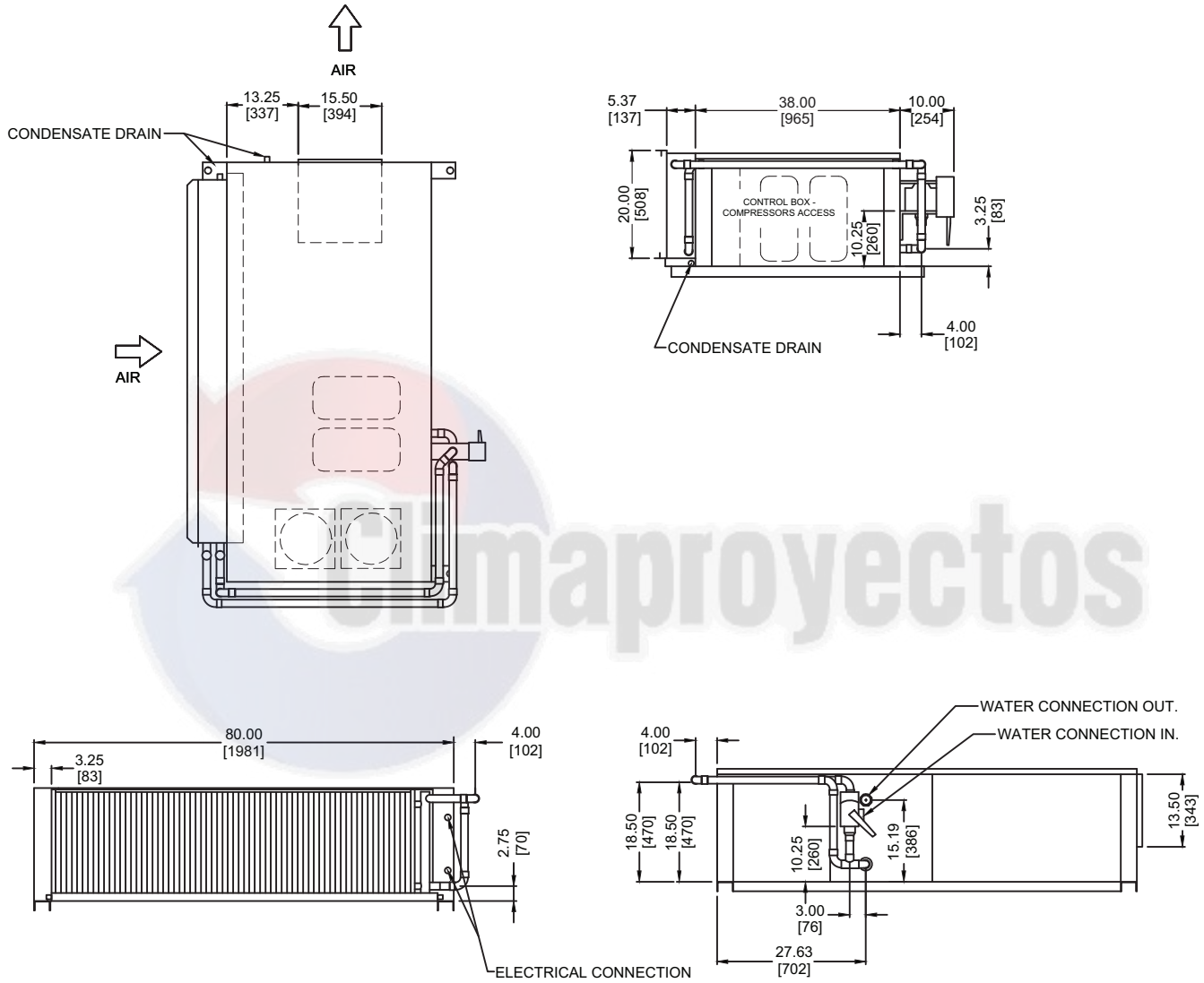

FILTER QTY & SIZE	(2) 20" X 34-1/2" X 1"
CONDENSATE DRAIN	3/4" FPT
WATER CONN. OUT	1" FPT
WATER CONN. IN	1" FPT

NOTE: Dimensions in inches [mm].

50HQ180-242 Units without Waterside Economizer

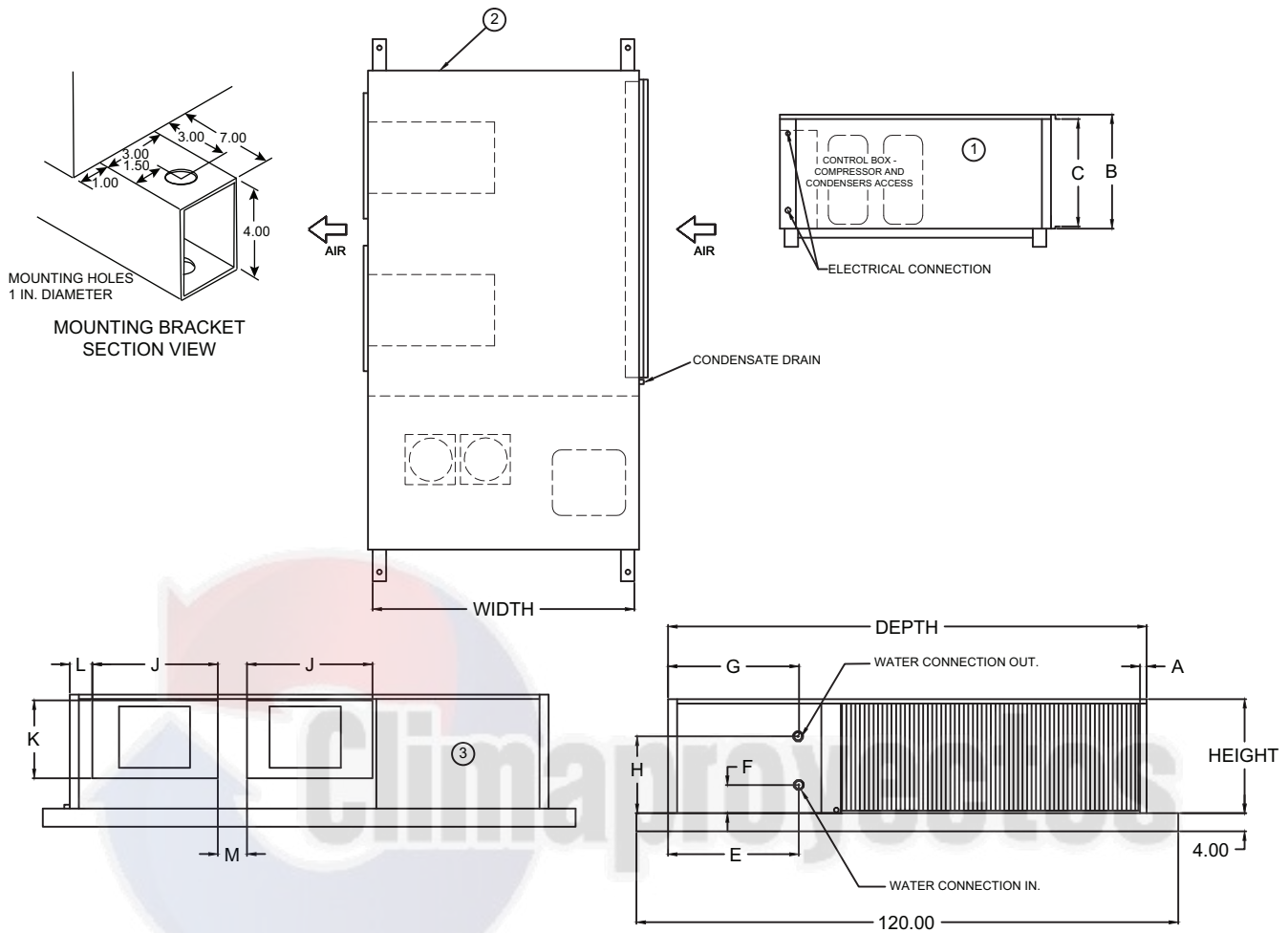

UNIT SIZE	HEIGHT	WIDTH	DEPTH	RETURN AIR			CONDENSER WATER CONNECTIONS					SUPPLY AIR				REPLACEMENT FILTER SIZE (NOMINAL)
				A	B	C	E	F	G	H	DIA. (FPT)	J	K	L	M	
180	25.25	60.25	106.50	2.00	24.00	22.00	22.50	7.25	22.00	16.00	1.25	27.75	17.25	5.00	4.00	2 - (24 x 34 x 1)
242	36.00	60.25	106.50	2.00	36.00	34.00	24.50	8.00	24.00	19.62	1.25	23.75	19.75	7.75	9.75	2 - (17.25 x 34.50 x 1)

SERVICE ACCESS TO:

①	②	③
CONTROLS COMPRESSORS	BLOWER AND MOTOR	COMP. REFIG. COMPONENTS

NOTES:

- All dimensions in inches.
- Units with two supply outlets require a pair of pants duct connection.

50HQP180-242 Units with Waterside Economizer

RIGHT RETURN
LEFT DISCHARGE

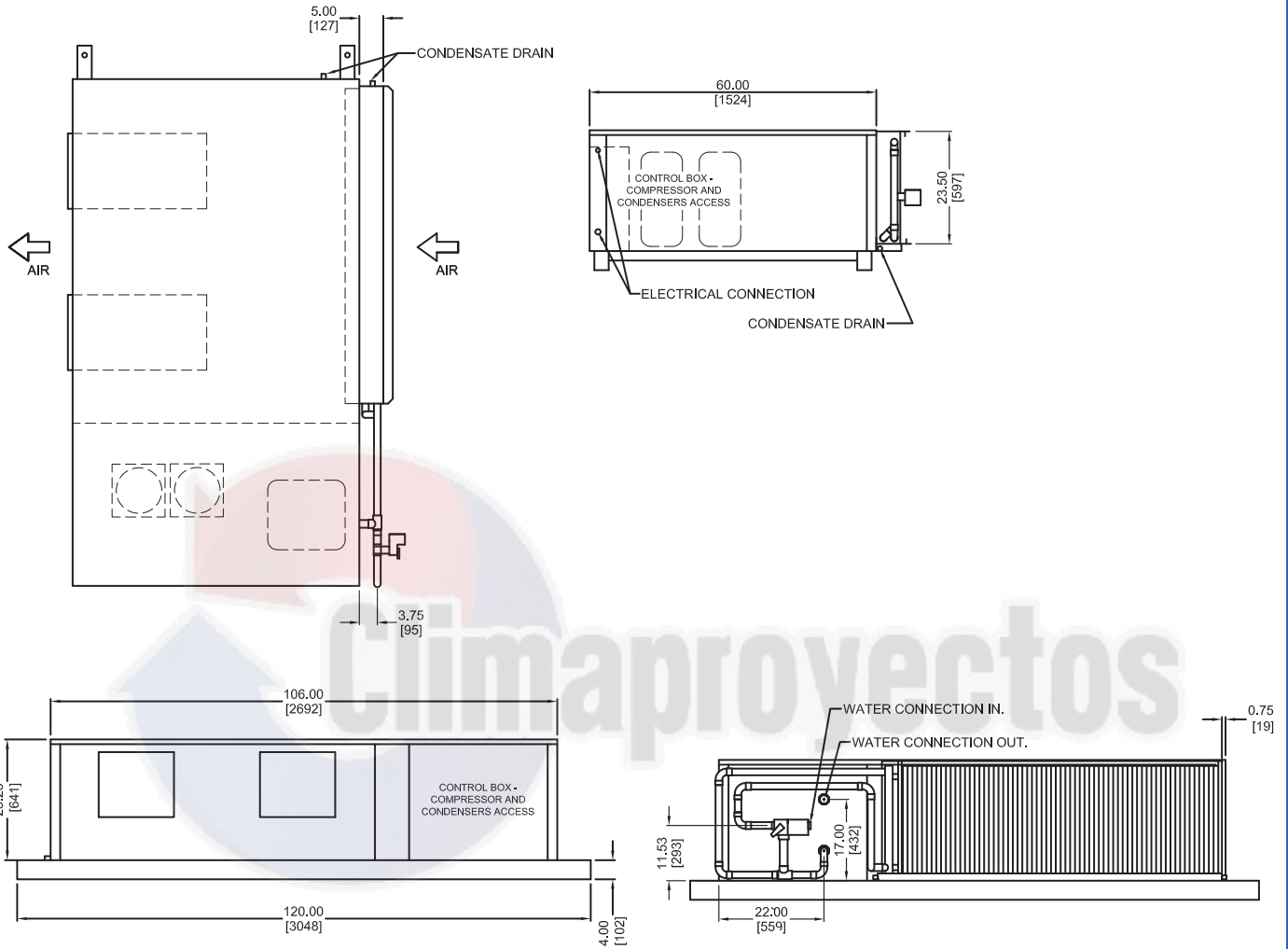

FILTER QTY & SIZE	(2) 23-1/4" x 34-1/2" x 1"
CONDENSATE DRAIN	(3) 3/4" FPT
WATER CONN. OUT	1.5" FPT
WATER CONN. IN	2" FPT

NOTES:

1. Dimensions in inches [mm].
2. Units with two supply outlets require a pair of pants duct connection.

50VQP072-096 Units Front Return, Top Supply, with Economizer

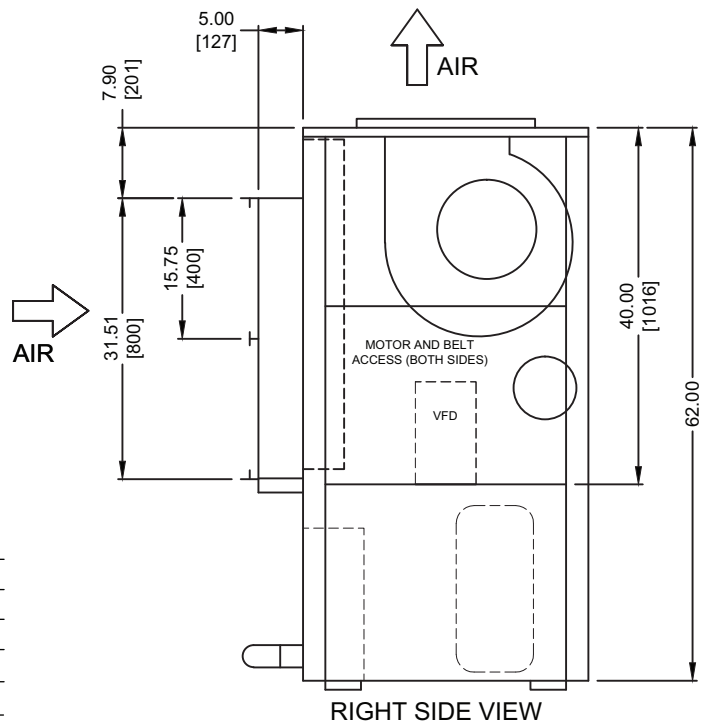
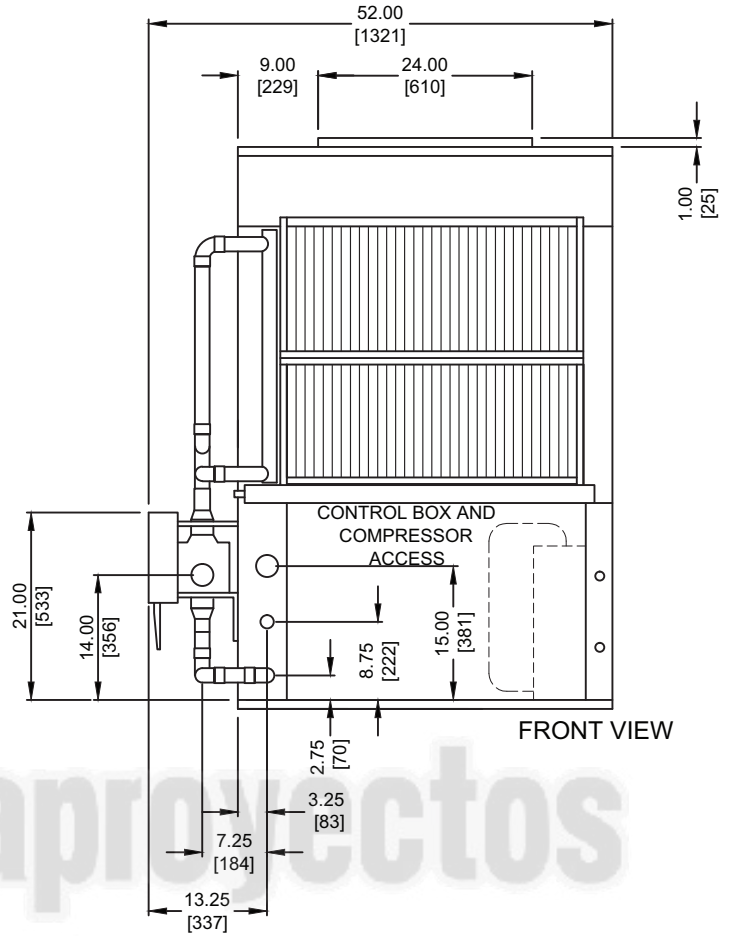
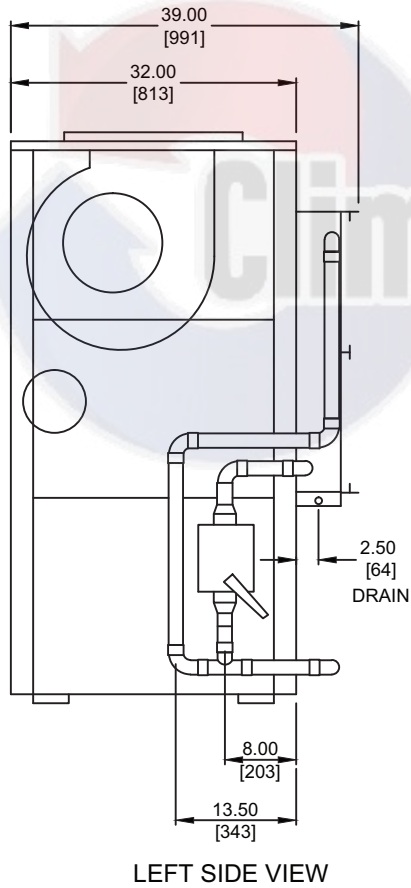
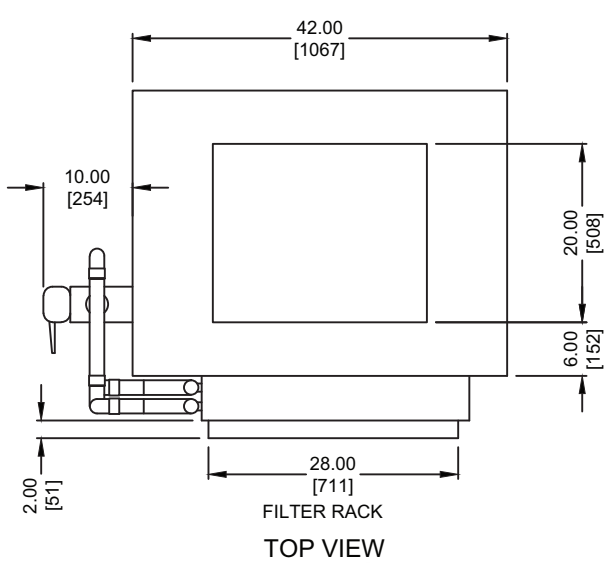

FILTER QTY & SIZE	(2) 20" x 34-1/2" x 1"
CONDENSATE CONN.	3/4" FPT
WATER CONN. OUT	1" FPT
WATER CONN. IN	2" FPT
SIZE	50VQP072-096

50VQP120 Units Front Return, Top Supply, with Economizer

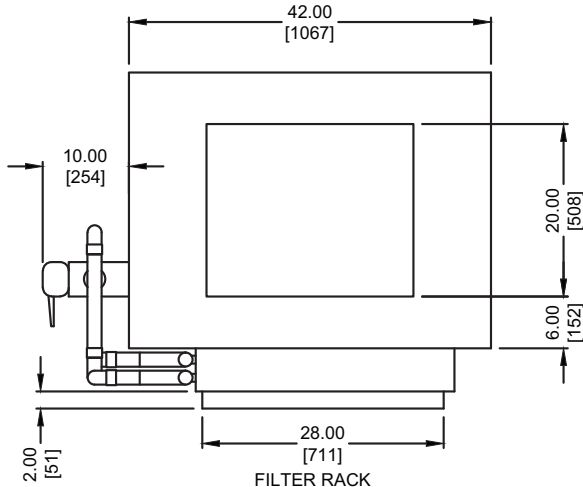

TOP VIEW

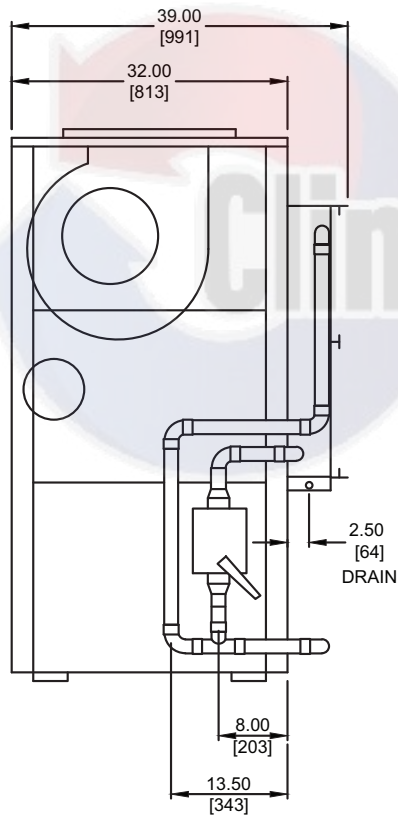

LEFT SIDE VIEW

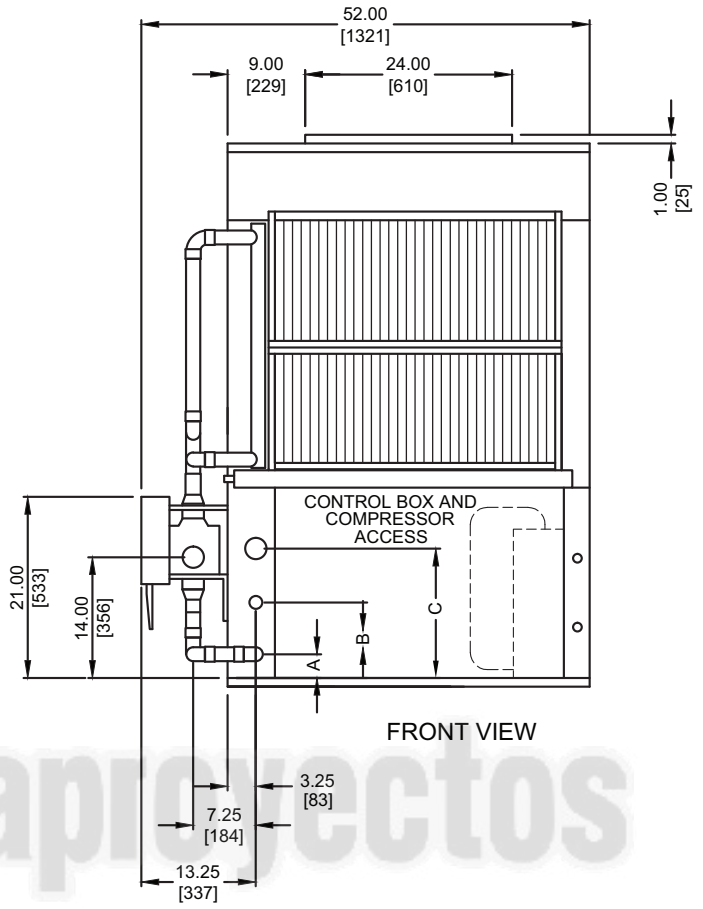

FRONT VIEW

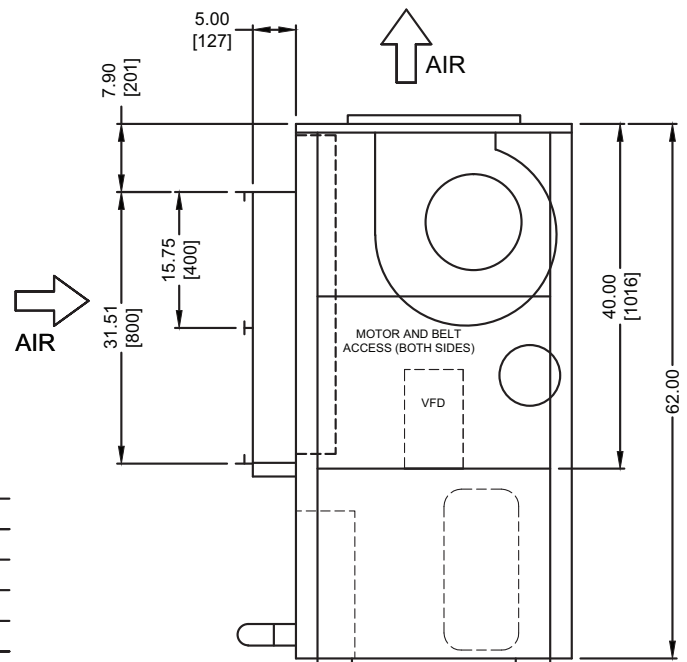

RIGHT SIDE VIEW

FILTER QTY. & SIZE	(2) 20" x 34-1/2" x 1"
CONDENSATE CONN.	3/4" FPT
WATER CONN. OUT	1-1/2" FPT
WATER CONN. IN	2" FPT
C	15"
B	9"
A	3"
SIZE	50VQP120

50VQP151 and 181 Units, Front Return, Top Supply, with Economizer

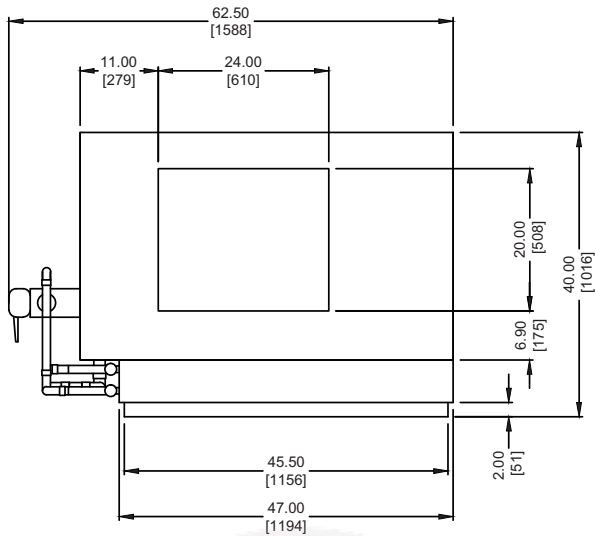

TOP VIEW

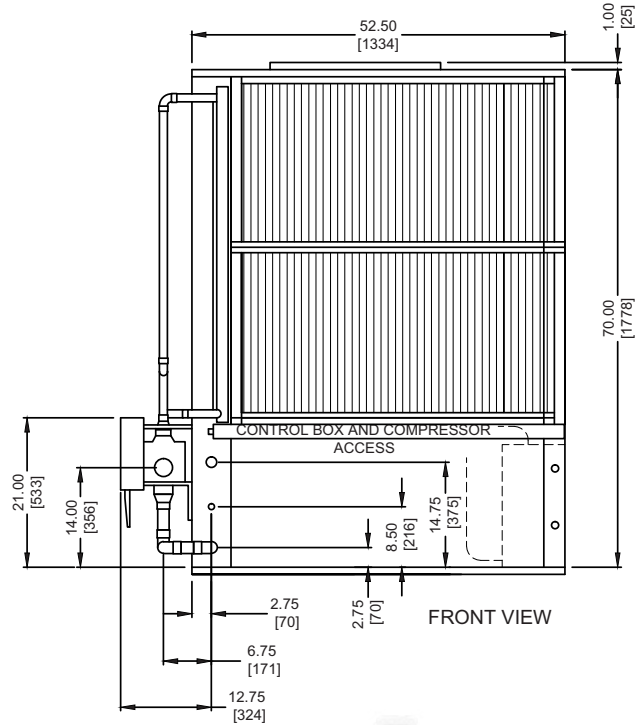

FRONT VIEW

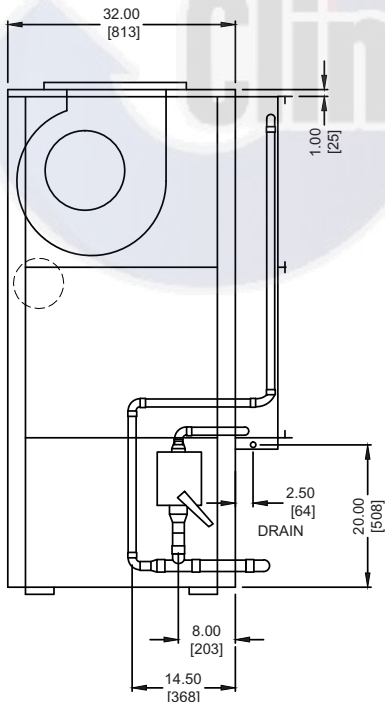

LEFT SIDE VIEW

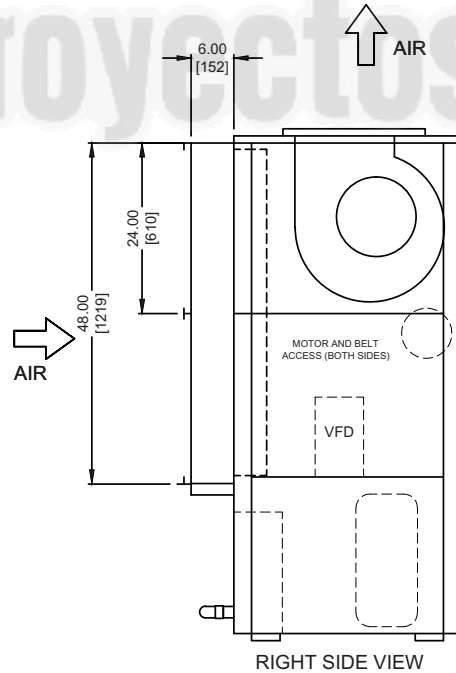

RIGHT SIDE VIEW

FILTER QTY. & SIZE	(4) 24" x 24" x 1"
CONDENSATE CONN.	3/4" FPT
WATER CONN. OUT	1.50" FPT
WATER CONN. IN	2" FPT
SIZE	50VQP151-181

50VQP210-300 Units, Front Return, Top Supply, with Economizer and Hot Water Coil

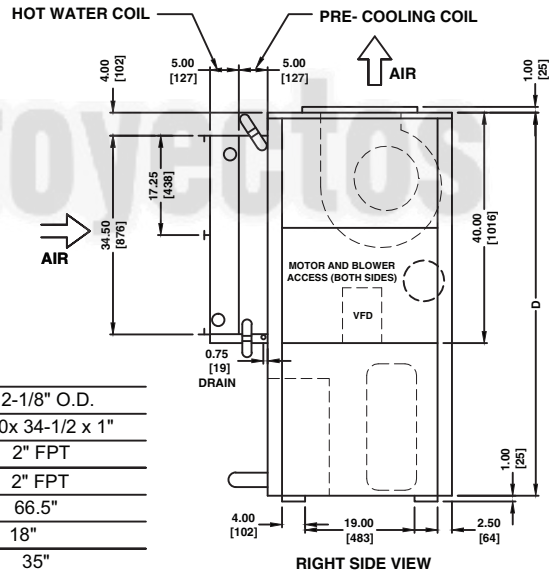
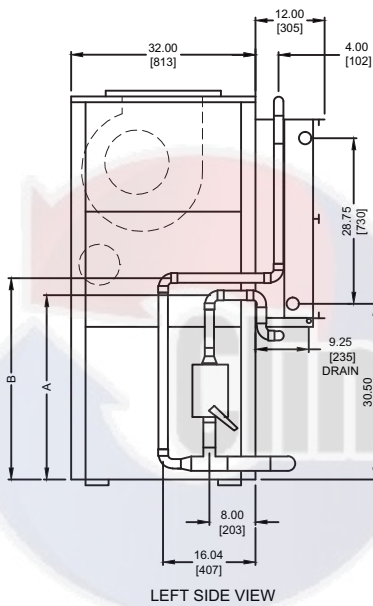
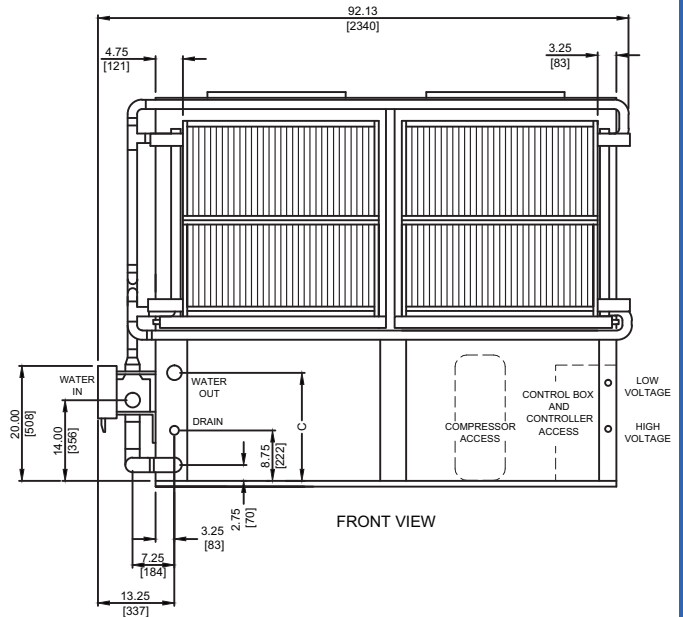
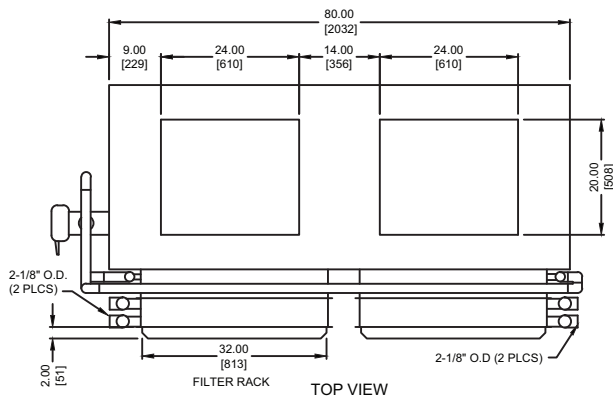

HOT WATER COIL CONN.	(4) 2-1/8" O.D.	(4) 2-1/8" O.D.	(4) 2-1/8" O.D.
FILTER QTY. & SIZE	(4) 20 x 34-1/2 x 1"	(4) 20x 34-1/2 x 1"	(4) 20x 34-1/2 x 1"
WATER CONN. OUT	2" FPT	2" FPT	2" FPT
WATER CONN. IN	2" FPT	2" FPT	2" FPT
D	62"	66.5"	66.5"
C	18"	18"	18"
B	31"	35"	35"
A	28"	32"	32"
DIMENSION	50VQP210	50VQP240	50VQP300

NOTE: Units with two supply outlets require a pair of pants duct connection.

50VQP360 Units, Front Return, Top Supply, with Economizer, with Hot Water Coil

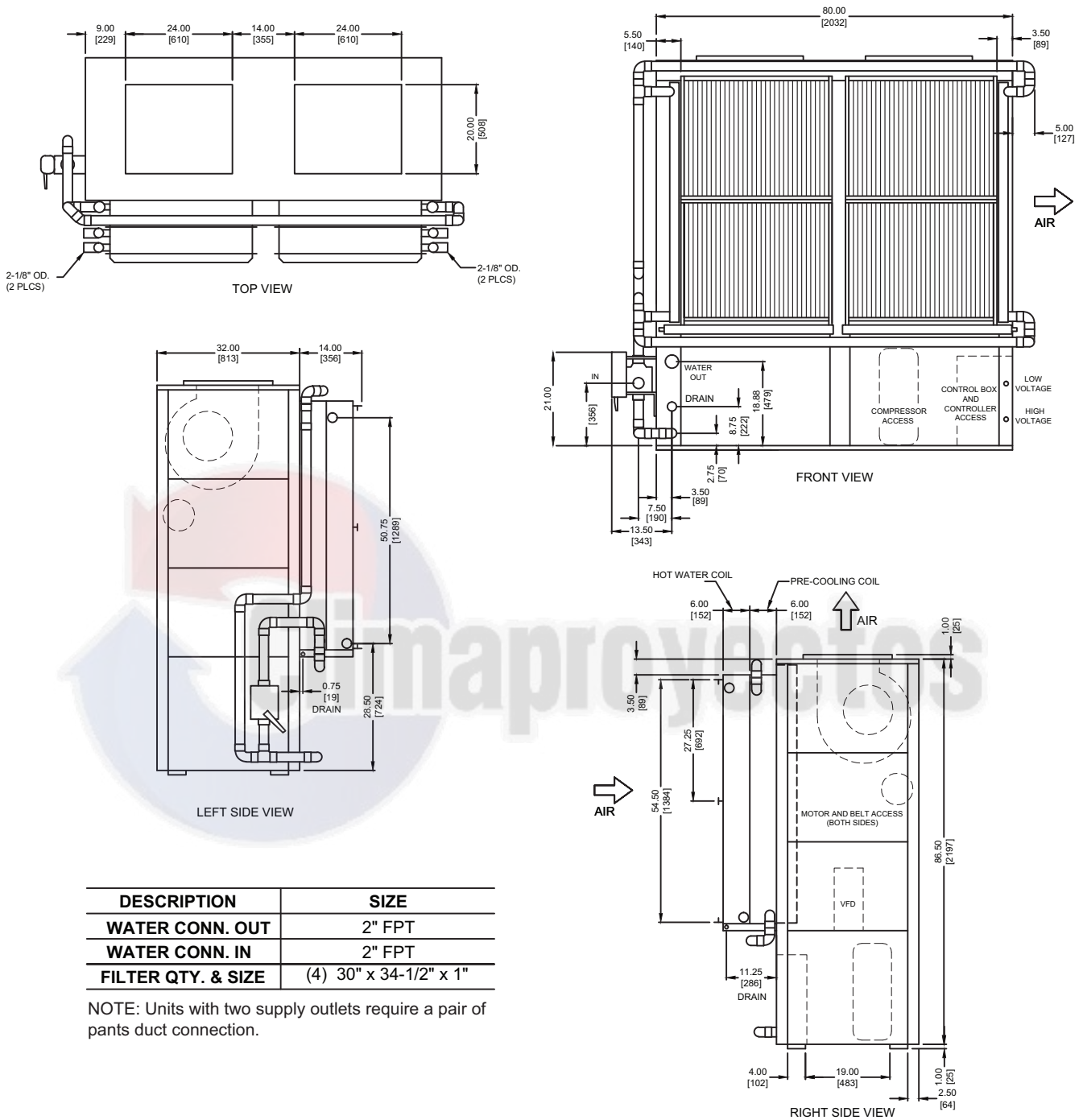

DESCRIPTION	SIZE
WATER CONN. OUT	2" FPT
WATER CONN. IN	2" FPT
FILTER QTY. & SIZE	(4) 30" x 34-1/2" x 1"

NOTE: Units with two supply outlets require a pair of pants duct connection.

50HQP Corner Weights

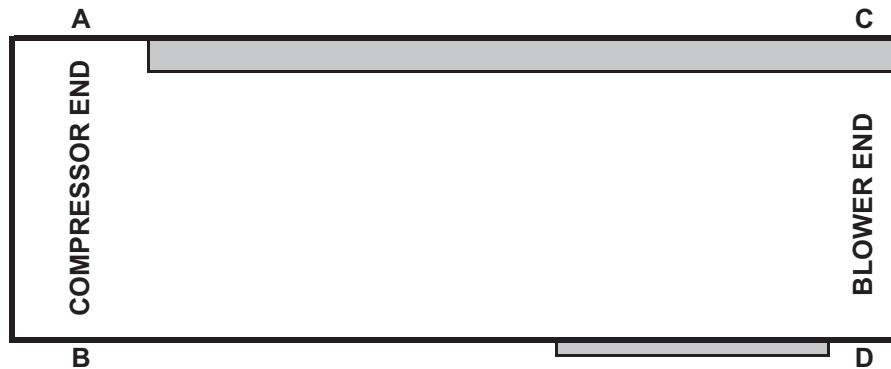

50HQP UNIT SIZE	CORNER WEIGHTS (lb)			
	A	B	C	D
072	147	274	137	112
096	155	287	143	117
120	206	382	191	156
150	233	434	216	177
180	337	626	312	255
242	365	677	337	276

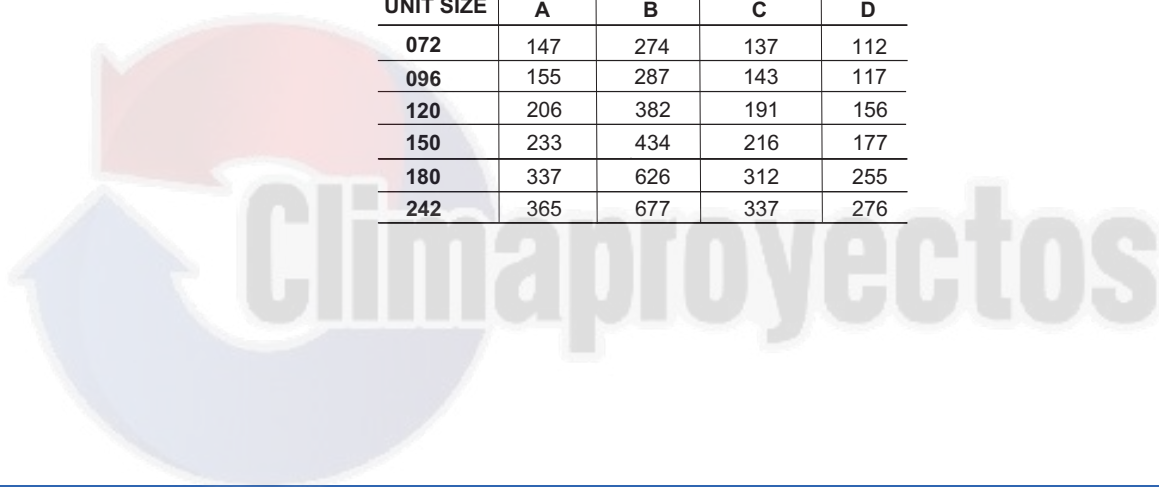

50HQP072-150 Units Service Clearances

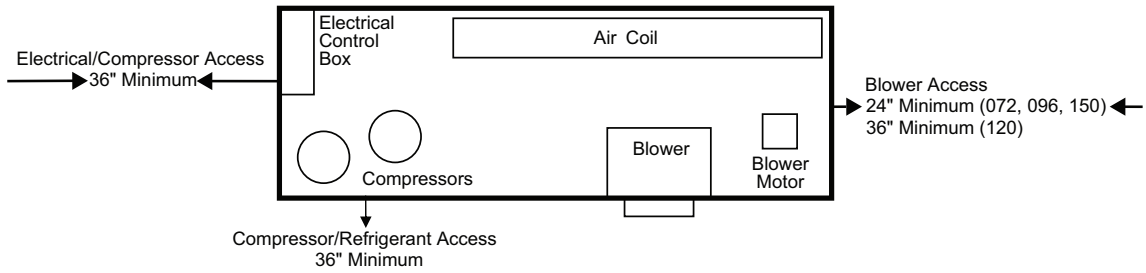

50HQP180-242 Units Service Clearances

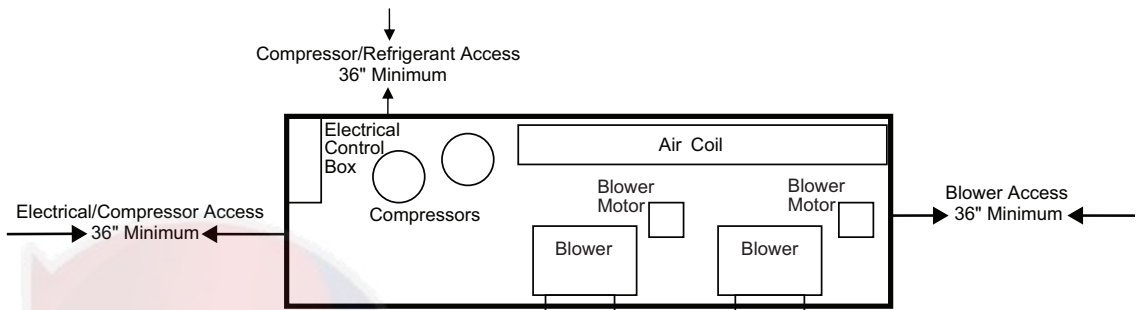

NOTE: The local electric codes may require 36" or more clearance at all electrical control boxes.

50VQP072-181 Units Service Clearances

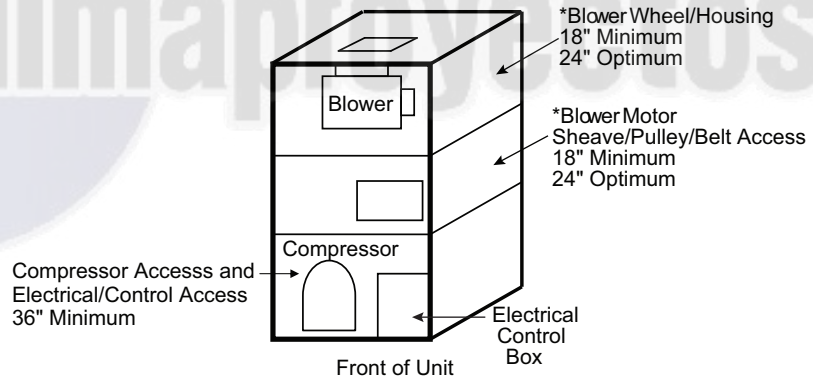

50VQP210-360 Units Service Clearances

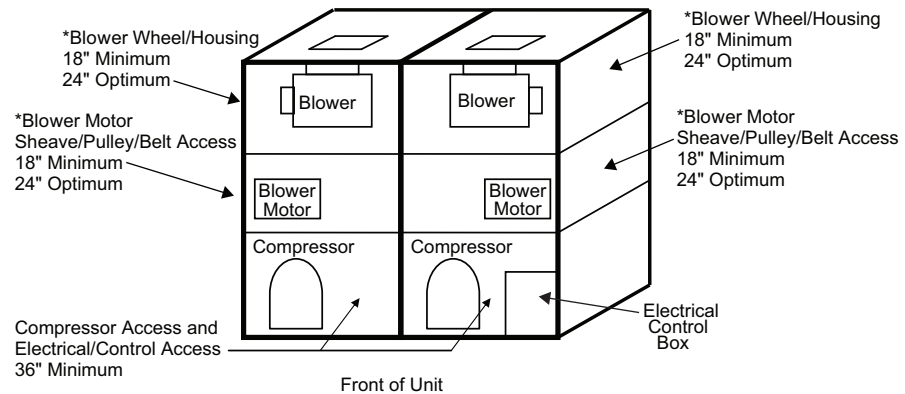

* Blower motor and blower housing access is required on BOTH SIDES of the unit.

50VQP072-181 Units Take Apart Construction

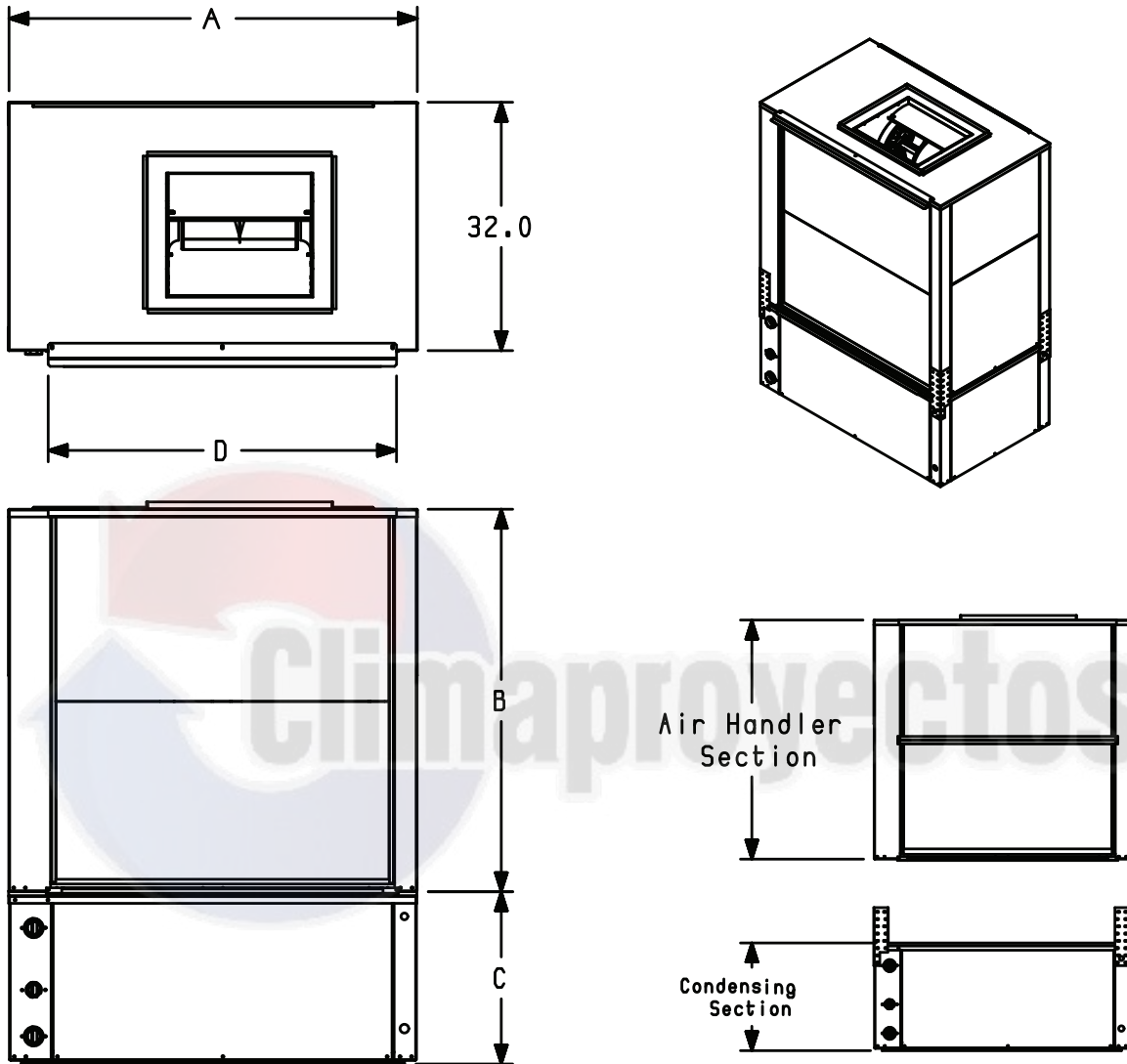

Model	WIDTH (in.)		HEIGHT (in.)		FILTER RACK (in.)		WEIGHTS (lb)	
	A	B	C	D	AH	CS		
50VQP072	42	42	22	33	204	396		
50VQP096	42	42	22	33	242	468		
50VQP120	42	42	22	33	264	511		
50VQP151	52.50	50	22	45	330	640		
50VQP181	52.50	50	22	45	360	700		

LEGEND

AH — Air Handler Section

CS — Condensing Section

Dimensions (cont)



50VQP210-360 Units Take Apart Construction

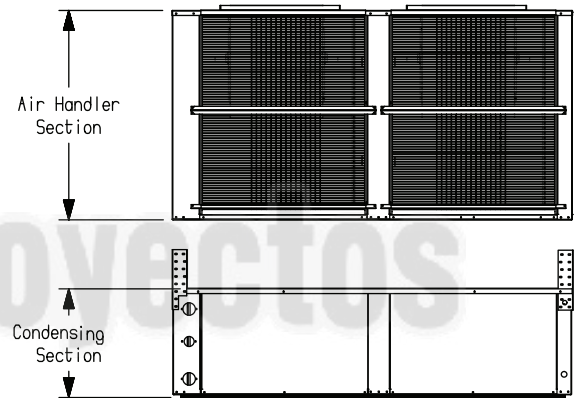
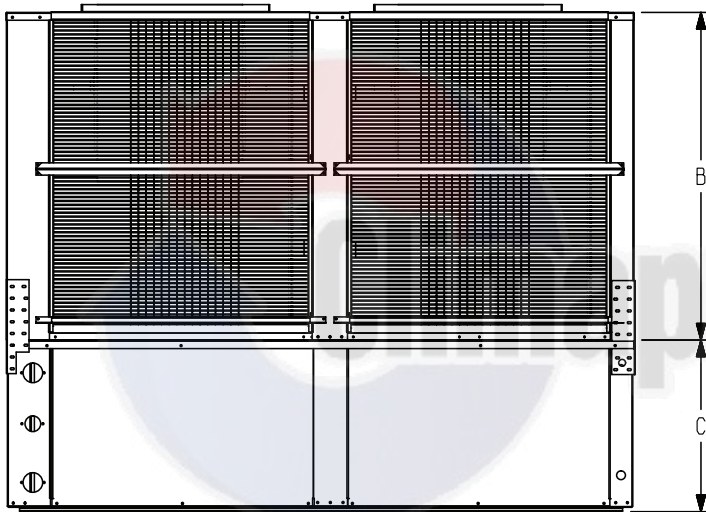
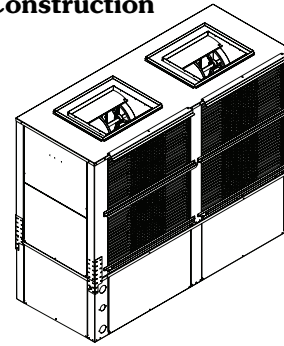
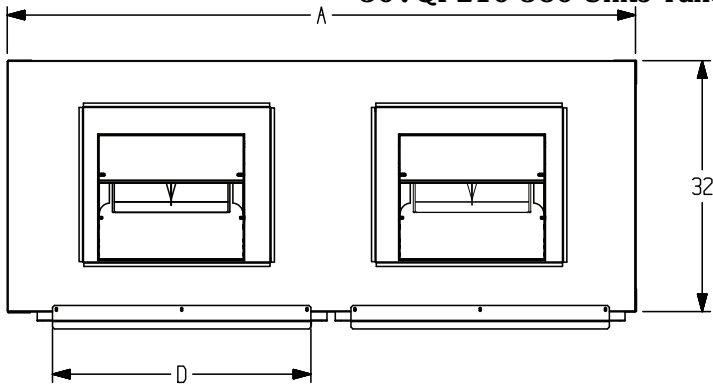

Model	WIDTH (in.)		HEIGHT (in.)		FILTER RACK (in.)	WEIGHTS (in.)	
	A		B	C	D	AH	CS
50VQP210	80		42	22	33	408	792
50VQP240	80		42	26	33	460	890
50VQP300	80		42	26	33	500	970
50VQP360	80		62	27	33	595	1155

LEGEND
AH — Air Handler Section
CS — Condensing Section

Performance data



Please see the WSHP Builder for cooling and heating performance data.

Antifreeze Correction Table

ANTIFREEZE TYPE	ANTIFREEZE%	COOLING			HEATING		WPD CORRECTION FACTOR
		EWT 90°F			EWT 30°F		
		Total Capacity	Sensible Capacity	kW	Heating Capacity	kW	EWT 30°F
Water	0	1.000	1.000	1.000	1.000	1.000	1.000
	5	0.997	0.997	1.004	0.989	0.997	1.060
Propylene Glycol	10	0.994	0.994	1.006	0.986	0.995	1.125
	15	0.990	0.990	1.009	0.978	0.988	1.190
	25	0.983	0.983	1.016	0.960	0.979	1.300
	30	0.979	0.979	1.020	0.950	0.970	1.510
	35	0.975	0.974	1.024	0.940	0.969	1.834
	5	0.997	0.997	1.003	0.990	0.997	1.060
Methanol	10	0.996	0.996	1.005	0.979	0.993	1.100
	15	0.994	0.994	1.008	0.970	0.990	1.140
	20	0.992	0.992	1.011	0.961	0.987	1.248
	25	0.990	0.990	1.014	0.955	0.984	1.220
	30	0.985	0.985	1.017	0.947	0.979	1.260
Ethanol	5	0.998	0.998	1.002	0.981	0.994	1.160
	10	0.996	0.996	1.004	0.960	0.988	1.230
	15	0.992	0.992	1.006	0.944	0.983	1.280
	25	0.986	0.986	1.009	0.917	0.974	1.400
	30	0.982	0.982	1.012	0.900	0.967	1.420
Ethylene Glycol	5	0.997	0.997	1.003	0.993	0.998	1.060
	10	0.995	0.995	1.004	0.986	0.996	1.120
	15	0.992	0.992	1.005	0.980	0.993	1.190
	25	0.988	0.988	1.009	0.970	0.990	1.330
	30	0.985	0.985	1.012	0.965	0.987	1.400

LEGEND

- EWT** — Entering Water Temperature
- WPD** — Water Pressure Differential



50HQP072-242 Blower Performance (cfm)

50HQP UNIT SIZE	MOTOR SHEAVE	RATED AIRFLOW	AVAILABLE EXTERNAL STATIC PRESSURE (in. wg) WET COIL AND FILTER INCLUDED												
			0.10	0.20	0.30	0.40	0.50	0.60	0.70	0.80	0.90	1.00	1.10	1.20	
072	Closed	2,300	—	—	—	—	—	—	—	—	—	2,420	2,160	1,900	1,700
	Half Open		—	—	2,980	2,800	2,610	2,400	2,100	1,800	—	—	—	—	
	Open		2,780	2,590	2,350	2,050	1,780	—	—	—	—	—	—	—	
096	Closed	2,800	—	—	—	—	—	—	—	—	2,800	2,650	2,450	2,300	2,200
	Half Open		—	—	3,480	3,340	3,230	3,075	2,880	2,690	2,555	2,355	—	—	
	Open		3,110	2,965	2,835	2,615	2,460	2,275	—	—	—	—	—	—	
120	Closed	4,000	—	—	—	—	—	—	—	—	—	4,400	4,150	3,830	3,600
	Half Open		—	—	—	4,660	4,490	4,240	3,959	4,600	3,000	—	—	—	
	Open		4,680	4,490	4,270	4,000	3,700	3,370	—	—	—	—	—	—	
150	Closed	5,000	—	—	—	—	—	—	—	7,120	6,920	6,530	6,080	5,660	5,120
	Half Open		—	—	—	6,860	6,530	6,120	5,780	5,380	4,880	4,090	—	—	
	Open		6,770	6,300	5,880	5,430	4,970	4,340	3,750	—	—	—	—	—	
180	Closed	6,000	—	—	—	—	—	—	—	7,200	6,940	6,560	6,150	5,710	5,140
	Half Open		—	—	7,200	6,930	6,580	6,200	5,800	5,450	4,920	—	—	—	
	Open		6,780	6,350	5,970	5,540	5,050	4,510	—	—	—	—	—	—	
242	Closed	8,000	—	—	—	—	—	—	—	—	—	—	—	8,120	7,500
	Half Open		—	—	—	—	—	—	—	8,280	7,700	7,000	5,800	—	—
	Open		—	—	8,340	7,800	7,200	6,540	—	—	—	—	—	—	—

NOTE: Fan performance table is based on drive package with standard motor.

50VQP072-300 Blower Performance (cfm)

50VQP UNIT SIZE	MOTOR SHEAVE	RATED AIRFLOW	AVAILABLE EXTERNAL STATIC PRESSURE (in. wg) WET COIL AND FILTER INCLUDED												
			0.10	0.20	0.30	0.40	0.50	0.60	0.70	0.80	0.90	1.00	1.10	1.20	
072	Closed	2,300	—	—	—	—	—	—	—	—	—	2,420	2,160	1,900	1,700
	Half Open		—	—	2,980	2,800	2,610	2,400	2,100	1,800	—	—	—	—	
	Open		2,780	2,590	2,350	2,050	1,780	—	—	—	—	—	—	—	
096	Closed	2,800	—	—	—	—	—	—	—	—	2,800	2,650	2,450	2,300	2,200
	Half Open		—	—	3,480	3,340	3,230	3,075	2,880	2,690	2,555	2,355	—	—	
	Open		3,110	2,965	2,835	2,615	2,460	2,275	—	—	—	—	—	—	
120	Closed	4,000	—	—	—	—	—	—	—	—	—	4,400	4,150	3,830	3,600
	Half Open		—	—	—	4,660	4,490	4,240	3,959	4,600	3,000	—	—	—	
	Open		4,680	4,490	4,270	4,000	3,700	3,370	—	—	—	—	—	—	
151	Closed	5,000	—	—	—	—	—	—	—	7,120	6,920	6,530	6,080	5,660	5,120
	Half Open		—	—	—	6,860	6,530	6,120	5,780	5,380	4,880	4,090	—	—	
	Open		6,770	6,300	5,880	5,430	4,970	4,340	3,750	—	—	—	—	—	
181	Closed	6,000	—	—	—	—	—	—	—	7,200	6,940	6,560	6,150	5,710	5,140
	Half Open		—	—	7,200	6,930	6,580	6,200	5,800	5,450	4,920	—	—	—	
	Open		6,780	6,350	5,970	5,540	5,050	4,510	—	—	—	—	—	—	
210	Closed	7,000	—	—	—	—	—	—	—	—	—	—	—	7,800	7,500
	Half Open		—	—	—	—	—	—	8,600	8,200	7,600	6,900	5,240	—	—
	Open		8,840	8,400	8,000	7,560	7,000	6,400	—	—	—	—	—	—	
240	Closed	8,000	—	—	—	—	—	—	—	—	—	9,000	8,800	8,330	7,660
	Half Open		—	—	—	—	9,320	8,980	8,480	7,900	7,200	6,000	—	—	
	Open		9,360	8,980	8,540	8,000	7,400	6,740	—	—	—	—	—	—	
300	Closed	10,000	—	—	—	—	—	—	—	10,000	9,650	9,300	8,950	8,600	8,200
	Half Open		—	10,500	10,100	9,700	8,900	8,500	8,100	—	—	—	—	—	
	Open		9,900	9,100	8,700	8,300	—	—	—	—	—	—	—	—	

NOTE: Fan performance table is based on drive package with standard motor

50VQP360 Blower Performance (cfm)

50VQP UNIT SIZE	MOTOR SHEAVE	RATED AIRFLOW	AVAILABLE EXTERNAL STATIC PRESSURE (in. wg) WET COIL AND FILTER INCLUDED													
			0.20	0.30	0.40	0.60	0.80	1.00	1.20	1.40	1.60	1.80	2.00	2.20		
360	Closed	12,000	—	—	—	—	—	—	—	—	—	—	—	—	12,900	10,800
	Half Open		—	—	—	—	—	—	13,050	11,850	10,350	7,500	—	—	—	—
	Open		12,200	11,575	10,950	9,600	7,800	—	—	—	—	—	—	—	—	—

NOTE: Fan performance table is based on drive package with standard motor

50HQP072-242 Standard Duty Motor (No VFD) Electrical Data

50HQP UNIT SIZE	VOLTAGE (V-Ph-Hz) ^a	VOLTAGE MIN/MAX	COMPRESSOR (x2)		BLOWER MOTOR			MIN CIRCUIT AMPS	MAX FUSE/HACR ^b
			RLA	LRA	QTY	HP	FLA		
072	208/230-1-60	197/253	16.7	79.0	1	1.0	7.0	44.6	60
	208/230-3-60	197/253	10.4	73.0	1	1.0	3.6	27.0	35
	460-3-60	414/506	5.8	38.0	1	1.0	1.8	14.9	20
	208-230/1/60	197/253	15.4	83.9	1	1.5	8.5	43.2	50
	208-230/3/60	197/253	10.4	73.0	1	1.5	4.8	28.2	35
	460/3/60	414/506	5.8	38.0	1	1.5	2.4	15.5	20
	208-230/1/60	197/253	16.7	79.0	1	2.0	9.8	47.4	60
096	208-230/3/60	197/253	10.4	73.0	1	2.0	6.2	29.6	40
	460/3/60	414/506	5.8	38.0	1	2.0	3.1	16.2	20
	208/230-1-60	197/253	19.6	130.0	1	2.0	9.8	53.9	70
	208/230-3-60	197/253	13.7	83.0	1	2.0	6.2	37.0	50
120	460-3-60	414/506	6.2	41.0	1	2.0	3.1	17.1	20
	575-3-60	518/632	4.8	33.0	1	2.0	2.6	13.4	15
	208/230-3-60	197/253	15.6	110.0	1	3.0	8.0	43.1	50
	460-3-60	414/506	7.8	52.0	1	3.0	3.9	21.5	25
	575-3-60	518/632	5.8	38.9	1	3.0	3.7	16.8	20
150	208/230-3-60	197/253	15.6	110.0	1	5.0	13.4	48.5	60
	460-3-60	414/506	7.8	52.0	1	5.0	6.6	24.2	30
	575-3-60	518/632	5.8	38.9	1	5.0	5.4	18.5	20
	208/230-3-60	197/253	19.2	136.0	1	3.0	9.2	52.4	70
	460-3-60	414/506	8.7	66.1	1	3.0	4.3	23.9	30
180	575-3-60	518/632	6.9	55.3	1	3.0	3.7	19.2	25
	208/230-3-60	197/253	19.2	136.0	1	5.0	13.4	56.6	70
	460-3-60	414/506	8.7	66.1	1	5.0	6.6	26.2	30
	575-3-60	518/632	6.9	55.3	1	5.0	5.4	20.9	25
	208/230-3-60	197/253	22.4	149.0	2	2.0	6.2	62.8	80
242	460-3-60	414/506	10.6	75.0	2	2.0	3.1	30.1	40
	575-3-60	518/632	7.7	54.0	2	2.0	2.6	22.5	30
	208/230-3-60	197/253	22.4	149.0	2	3.0	8.0	66.4	80.0
	460-3-60	414/506	10.6	75.0	2	3.0	3.9	31.7	40.0
	575-3-60	518/632	7.7	54.0	2	3.0	3.7	24.7	30.0
	208/230-3-60	197/253	22.4	149.0	2	5.0	13.4	77.2	90.0
	460-3-60	414/506	10.6	75.0	2	5.0	6.6	37.1	45.0
242	575-3-60	518/632	7.7	54.0	2	5.0	5.4	28.1	35
	208/230-3-60	197/253	30.1	225.0	2	2.0	3.9	75.5	100
	460-3-60	414/506	16.7	114.0	2	2.0	3.1	43.8	60
	575-3-60	518/632	12.2	80.0	2	2.0	2.6	32.7	40
	208/230-3-60	197/253	30.1	225.0	2	3.0	8.0	83.7	110
	460-3-60	414/506	16.7	114.0	2	3.0	3.9	45.4	60
	575-3-60	518/632	12.2	80.0	2	3.0	3.7	34.9	45
242	208/230-3-60	197/253	30.1	225.0	2	5.0	13.4	94.5	110
	460-3-60	414/506	16.7	114.0	2	5.0	6.6	50.8	60
	575-3-60	518/632	12.2	80.0	2	5.0	5.4	38.3	50

NOTE(S):

- a. A voltage variation of $\pm 10\%$ of nameplate rating is acceptable. Phase imbalance shall not exceed 2%.
- b. HACR circuit breaker in U.S.A. only.

50VQP072-360 Standard Duty Motor (No VFD) Electrical Data

50VQP UNIT SIZE	VOLTAGE (V-Ph-Hz) ^a	VOLTAGE MIN/MAX	COMPRESSOR		BLOWER MOTOR			MIN CIRCUIT AMPS	MAX FUSE/ HACR ^b
			RLA	LRA	QTY	FLA	HP		
072	208/230-1-60	197/253	16.7	79.0	1	7.0	1.0	44.6	60
	208/230-3-60	197/253	10.4	73.0	1	3.6	1.0	27.0	35
	460-3-60	414/506	5.8	38.0	1	1.8	1.0	14.9	20
	208/230-1-60	197/253	15.4	83.9	1	8.5	1.5	43.2	50
	208/230-3-60	197/253	10.4	73.0	1	4.8	1.5	28.2	35
	460-3-60	414/506	5.8	38.0	1	2.4	1.5	15.5	20
	208/230-1-60	197/253	16.7	79.0	1	9.8	2.0	47.4	60
096	208/230-3-60	197/253	10.4	73.0	1	6.2	2.0	29.6	40
	460-3-60	414/506	5.8	38.0	1	3.1	2.0	16.2	20
	208/230-1-60	197/253	19.6	130.0	1	8.5	1.5	52.6	70
	208/230-3-60	197/253	13.7	83.1	1	4.8	1.5	35.6	45
	460-3-60	414/506	6.2	41.0	1	2.4	1.5	16.4	20
	575-3-60	518/632	4.8	33.0	1	2.0	1.5	12.8	15
	208/230-1-60	197/253	19.6	130.0	1	9.8	2.0	53.9	70
120	208/230-3-60	197/253	13.7	83.0	1	6.2	2.0	37.0	50
	460-3-60	414/506	6.2	41.0	1	3.1	2.0	17.1	20
	575-3-60	518/632	4.8	33.0	1	2.6	2.0	13.4	15
	208/230-1-60	197/253	26.3	134.0	1	9.8	2.0	69.0	90
	208/230-3-60	197/253	15.6	110.0	1	6.2	2.0	41.3	50
	460-3-60	414/506	7.8	52.0	1	3.1	2.0	20.7	25
	575-3-60	518/632	5.8	38.9	1	2.6	2.0	15.7	20
151	208/230-3-60	197/253	15.6	110.0	1	8.0	3.0	43.1	50
	460-3-60	414/506	7.8	52.0	1	3.9	3.0	21.5	25
	575-3-60	518/632	5.8	38.9	1	3.7	3.0	16.8	20
	208/230-3-60	197/253	15.6	110.0	1	13.4	5.0	48.5	60
	460-3-60	414/506	7.8	52.0	1	6.6	5.0	24.2	30
	575-3-60	518/632	5.8	38.9	1	5.4	5.0	18.5	20
	208/230-3-60	197/253	19.2	136.0	1	8.0	3.0	51.2	70
181	460-3-60	414/506	8.7	66.1	1	3.9	3.0	23.5	30
	575-3-60	518/632	6.9	55.3	1	3.7	3.0	19.2	25
	208/230-3-60	197/253	19.2	136.0	1	13.4	5.0	56.6	70
	460-3-60	414/506	8.7	66.1	1	6.6	5.0	26.2	30
	575-3-60	518/632	6.9	55.3	1	5.4	5.0	20.9	25
210	208/230-3-60	197/253	22.4	149.0	1	13.4	5.0	63.8	80
	460-3-60	414/506	10.6	75.0	1	6.6	5.0	30.5	40
	575-3-60	518/632	7.7	54.0	1	5.4	5.0	22.7	30
	208/230-3-60	197/253	29.5	195.0	2	4.8	1.5	76.0	100
	460-3-60	414/506	14.7	95.0	2	2.4	1.5	37.9	50
240	575-3-60	518/632	12.2	80.0	2	2.0	1.5	31.5	40
	208/230-3-60	197/253	29.5	195.0	2	6.2	2.0	78.8	100
	460-3-60	414/506	14.7	95.0	2	3.1	2.0	39.3	50
	575-3-60	518/632	12.2	80.0	2	2.6	2.0	32.7	40
	208/230-3-60	197/253	29.5	195.0	2	8.0	3.0	82.4	110
	460-3-60	414/506	14.7	95.0	2	3.9	3.0	40.9	50
	575-3-60	518/632	12.2	80.0	2	3.7	3.0	34.9	45
	208/230-3-60	197/253	29.5	195.0	2	13.4	5.0	93.2	110
	460-3-60	414/506	14.7	95.0	2	6.6	5.0	46.3	60
	575-3-60	518/632	12.2	80.0	2	5.4	5.0	38.3	50
240	208/230-3-60	197/253	30.1	225.0	2	6.2	2.0	80.1	110
	460-3-60	414/506	16.7	114.0	2	3.1	2.0	43.8	60
	575-3-60	518/632	12.2	80.0	2	3.7	3.0	34.9	45
	208/230-3-60	197/253	30.1	225.0	2	13.4	5.0	94.5	110
	460-3-60	414/506	16.7	114.0	2	6.6	5.0	50.8	60
575-3-60	518/632	12.2	80.0	2	5.4	5.0	38.3	50	

Electrical data (cont)



50VQP072-360 Standard Duty Motor (No VFD) Electrical Data (cont)

50VQP UNIT SIZE	VOLTAGE (V-Ph-Hz) ^a	VOLTAGE MIN/MAX	COMPRESSOR		BLOWER MOTOR			MIN CIRCUIT AMPS	MAX FUSE/ HACR ^b
			RLA	LRA	QTY	FLA	HP		
300	208/230-3-60	197/253	48.1	245.0	2	8.0	3.0	124.2	150
	460-3-60	414/506	18.6	125.0	2	3.9	3.0	49.7	60
	575-3-60	518/632	14.7	100.0	2	3.7	3.0	40.5	50
	208/230-3-60	197/253	48.1	245.0	2	13.4	5.0	135.0	175
	460-3-60	414/506	18.6	125.0	2	6.6	5.0	55.1	70
	575-3-60	518/632	14.7	100.0	2	5.4	5.0	43.9	50
360	208/230-3-60	197/253	55.8	340.0	2	13.4	5.0	152.4	200
	460-3-60	414/506	26.9	173.0	2	6.6	5.0	73.7	100
	575-3-60	518/632	23.7	132.0	2	5.4	5.0	64.1	80

NOTE(S):

- a. HACR circuit breaker in U.S.A. only.
- b. A voltage variation of $\pm 10\%$ of nameplate rating is acceptable. Phase imbalance shall not exceed 2%.



50HQP072-242, Inverter Duty Motor (with VFD) Electrical Data

50HQP UNIT SIZE	VOLTAGE (V-Ph-Hz) ^a	VOLTAGE MIN/MAX	COMPRESSOR (X2)		BLOWER MOTOR			MIN CIRCUIT AMPS	MAX FUSE/HACR ^b
			RLA	LRA	QTY	HP	FLA		
072	208-230/3/60	197/253	10.4	73.0	1	2.0	6.2	29.6	40
	460/3/60	414/506	5.8	38.0	1	2.0	3.1	16.2	20
	208-230/3/60	197/253	10.4	73.0	1	3.0	8.8	32.2	40
	460/3/60	414/506	5.8	38.0	1	3.0	4.3	17.4	25
096	208-230/3/60	197/253	13.7	83.1	1	2.0	6.2	37.0	50
	460/3/60	414/506	6.2	41.0	1	2.0	3.1	17.1	20
	208-230/3/60	197/253	13.7	83.1	1	3.0	8.8	39.6	50
	460/3/60	414/506	6.2	41.0	1	3.0	4.3	18.3	20
120	208-230/3/60	197/253	15.6	110.0	1	3.0	8.8	43.9	50
	460/3/60	414/506	7.8	52.0	1	3.0	4.3	21.9	25
	208-230/3/60	197/253	15.6	110.0	1	5.0	13.5	48.6	60
	460/3/60	414/506	7.8	52.0	1	5.0	6.2	23.8	30
150	208-230/3/60	197/253	19.2	136.0	1	3.0	8.8	52.0	70
	460/3/60	414/506	8.7	66.1	1	3.0	4.3	23.9	30
	208-230/3/60	197/253	19.2	136.0	1	5.0	13.5	56.7	70
	460/3/60	414/506	8.7	66.1	1	5.0	6.2	25.8	30
180	208-230/3/60	197/253	22.4	149.0	2	2.0	6.2	62.8	80
	460/3/60	414/506	10.6	75.0	2	2.0	3.1	30.1	40
	208-230/3/60	197/253	22.4	149.0	2	3.0	8.8	68.0	90
	460/3/60	414/506	10.6	75.0	2	3.0	4.3	32.5	40
	208-230/3/60	197/253	22.4	149.0	2	5.0	13.5	77.4	90
	460/3/60	414/506	10.6	75.0	2	5.0	6.2	36.3	45
242	208-230/3/60	197/253	30.1	225.0	2	2.0	6.2	80.1	110
	460/3/60	414/506	16.7	114.0	2	2.0	3.1	43.8	60
	208-230/3/60	197/253	30.1	225.0	2	3.0	8.8	85.3	110
	460/3/60	414/506	16.7	114.0	2	3.0	4.3	46.2	60
	208-230/3/60	197/253	30.1	225.0	2	5.0	13.5	94.7	110
	460/3/60	414/506	16.7	114.0	2	5.0	6.2	50.0	60

NOTE(S):

- a. A voltage variation of $\pm 10\%$ of nameplate rating is acceptable. Phase imbalance shall not exceed 2%.
- b. HACR circuit breaker in U.S.A. only.

LEGEND

- FLA** — Full Load Amps
- HACR** — Heating, Air Conditioning, and Refrigeration
- LRA** — Locked Rotor Amps
- RLA** — Rated Load Amps

50VQP072-360, Inverter Duty Motor (with VFD) Electrical Data

50VQP UNIT SIZE	VOLTAGE (V-Ph-Hz) ^a	VOLTAGE MIN/MAX	COMPRESSOR (X2)		BLOWER MOTOR			MIN CIRCUIT AMPS	MAX FUSE/HACR ^b
			RLA	LRA	QTY	HP	FLA		
072	208-230/3/60	197/253	10.4	73.0	1	2.0	6.2	29.6	40
	460/3/60	414/506	5.8	38.0	1	2.0	3.1	16.2	20
	208-230/3/60	197/253	10.4	73.0	1	3.0	8.8	32.2	40
	460/3/60	414/506	5.8	38.0	1	3.0	4.3	17.4	25
096	208-230/3/60	197/253	13.7	83.1	1	2.0	6.2	37.0	50
	460/3/60	414/506	6.2	41.0	1	2.0	3.1	17.1	20
	208-230/3/60	197/253	13.7	83.1	1	3.0	8.8	39.6	50
	460/3/60	414/506	6.2	41.0	1	3.0	4.3	18.3	20
120	208-230/3/60	197/253	15.6	110.0	1	2.0	6.2	41.3	50
	460/3/60	414/506	7.8	52.0	1	2.0	3.1	20.7	25
	208-230/3/60	197/253	15.6	110.0	1	3.0	8.8	43.9	50
	460/3/60	414/506	7.8	52.0	1	3.0	4.3	21.9	25
151	208-230/3/60	197/253	15.6	110.0	1	5.0	13.5	48.6	60
	460/3/60	414/506	7.8	52.0	1	5.0	6.2	23.8	30
	208-230/3/60	197/253	19.2	136.0	1	3.0	8.8	52.0	70
	460/3/60	414/506	8.7	66.1	1	3.0	4.3	23.9	30
181	208-230/3/60	197/253	19.2	136.0	1	5.0	13.5	56.7	70
	460/3/60	414/506	8.7	66.1	1	5.0	6.2	25.8	30
	208-230/3/60	197/253	22.4	149.0	1	5.0	13.5	63.9	80
	460/3/60	414/506	10.6	75.0	1	5.0	6.2	30.1	40
210	208-230/3/60	197/253	29.5	195.0	2	2.0	6.2	78.8	100
	460/3/60	414/506	14.7	95.0	2	2.0	3.1	39.3	50
	208-230/3/60	197/253	29.5	195.0	2	3.0	8.8	84.0	110
	460/3/60	414/506	14.7	95.0	2	3.0	4.3	41.7	50
240	208-230/3/60	197/253	29.5	195.0	2	5.0	13.5	93.4	110
	460/3/60	414/506	14.7	95.0	2	5.0	6.2	45.5	60
	208-230/3/60	197/253	30.1	225.0	2	2.0	6.2	80.1	110
	460/3/60	414/506	16.7	114.0	2	2.0	3.1	43.8	60
300	208-230/3/60	197/253	30.1	225.0	2	3.0	8.8	85.3	110
	460/3/60	414/506	16.7	114.0	2	3.0	4.3	46.2	60
	208-230/3/60	197/253	30.1	225.0	2	5.0	13.5	94.7	110
	460/3/60	414/506	16.7	114.0	2	5.0	6.2	50.0	60
360	208-230/3/60	197/253	48.1	245.0	2	3.0	8.8	125.8	150
	460/3/60	414/506	18.6	125.0	2	3.0	4.3	50.5	60
	208-230/3/60	197/253	48.1	245.0	2	5.0	13.5	94.7	110
	460/3/60	414/506	18.6	125.0	2	5.0	6.2	50.0	60
360	208-230/3/60	197/253	55.8	340.0	2	5.0	13.5	152.6	200
	460/3/60	414/506	26.9	173.0	2	5.0	6.2	72.9	90

NOTE(S):

- a. A voltage variation of ± 10% of nameplate rating is acceptable. Phase imbalance shall not exceed 2%.
- b. HACR circuit breaker in U.S.A. only.

LEGEND

- FLA — Full Load Amps
- HACR — Heating, Air Conditioning, and Refrigeration
- LRA — Locked Rotor Amps
- RLA — Rated Load Amps

Aquazone™ water source heat pump products are available in a flexible, efficient array of models, which can be used in all types of water loop, ground water, and ground loop systems. Use Aquazone™ products to provide optimal energy efficient solutions and adapt to the most challenging design requirements.

Aquazone™ Product Guide

50 SERIES	TYPE SIZE (tons)	APPLICATION
50HQP,VQP	Large Capacity 6-20 (HQP) 6-30 (VQP)	Environmentally balanced unit with Puron® refrigerant (R-410A) designed to handle large zoned areas for all geothermal and boiler/tower applications.
50PC	Compact 1/2-6	Compact WSHP with Puron refrigerant (R-410A) for boiler/tower, ground water, or ground loop systems.
50PS	Premium Efficiency 1/2-6	Premium, ultra efficient unit with Puron refrigerant (R-410A) for new boiler/tower, ground water, or ground loop systems.
50PEC	High Efficiency Console 3/4-1-1/2	Efficient console unit with Puron refrigerant (R-410A) and attractive design for finished interior, under-window installations.
50PT	Premium Efficiency 2-6	Premium, ultra efficient 2-stage unit with Puron refrigerant (R-410A) for new boiler/tower, ground water, or ground loop systems.
50PSW	Water-to-Water 2-35	Efficient unit with Puron refrigerant (R-410A) serves as an alternative to pre-heat or cool air. Unit can be used as a stand-alone or supplemental boiler/chiller in most hydronic heating applications. Also conditions process fluids, lubricants, and refrigerants.

Water loop system

Water loop (or boiler/tower) system applications typically include a number of units plumbed to a common piping system. For optimal performance, this system should be designed between 2.25 and 3 gpm per ton of cooling capacity. The system is comprised of highly efficient, packaged, reverse cycle heat pump units interconnected by a water loop. The water circuit serves as both a sink and source for heat absorption and rejection and is designed for entering water temperatures between 50°F and 90°F. Within this temperature range, units can heat or cool as required from the same water source. Transferring heat from warm to cold spaces in the building, whenever they coexist, conserves energy rather than creating new heat.

Refer to the **Carrier Water Source Heat Pump System Design Guide** for assistance with the design of water loop systems. The guide includes a practical approach for the latest and most current design recommendations, including:

- Product application including horizontal, vertical, console, rooftop and water-to-water applications.
- Ventilation methods and system design including energy recovery.
- Acoustical considerations for different product types.
- Addressing indoor air quality (IAQ) issues such as condensate removal, humidity control.
- Air distribution design including diffuser selection/layout and ductwork design.
- Hydronic system design including pipe sizing/layout and boiler/tower sizing.

- Control configurations such as stand alone, DDC, DCV (demand controlled ventilation), and VVT® (variable volume and temperature) controls.
- WSHP Efficiency/Operational Cost Comparison chart.
- System variations such as a system without a boiler, variable pumping, and VAV for interior use.

Ground water systems

To use Aquazone™ units in ground water applications, extended range should be specified. This will provide factory-installed insulation on the coaxial coil to prevent condensate from dripping when entering water temperatures are below 60°F. In addition, the copper coaxial coil installed on the Aquazone™ units may not be suitable for all water conditions. Refer to the Water Conditioning section for proper coaxial coil material selection.

Surface water system

This system is typically located near a lake or pond. In this application, the loop can be submerged in a series of coils beneath the water surface. The number of coils required depends on system load and design. This application requires minimum piping and excavation.

Open loop system

This system is used where ground water is plentiful. In this application, ground water is pumped through supply piping from the well to the building. The water is then pumped back into the ground through a discharge well as it leaves the building. An additional heat exchanger is usually installed between the building water piping system and the ground water piping system. This design limits the amount of piping and excavation required.

Aquazone™ units are provided with a standard TXV and are rated to extremely low temperatures to self-adjust the refrigeration circuit. Water regulating valves are recommended on open loop systems. To conserve water on this type of system, a slow opening/closing solenoid valve is recommended.

Ground loop systems

There are many commonly specified designs for ground loop applications. Typical designs include vertical loops and horizontal loops. In some applications, water is piped from the ground or lake directly to the water source heat pump. Piping is limited to the amount of pipe required to get the water from the source to the unit.

NOTE: When using Aquazone™ water source heat pumps in ground loop systems, refer to design considerations in the ground water system section.

Horizontal ground loop

This system is used when adequate space is available and trenching can be easily accomplished. A series of parallel pipes are laid out in trenches 3 to 6 feet below the ground surface, and then back-filled. Often, multiple pipes are used to maximize the heat transfer capability of each trench. The amount of pipe and the size of the ground loop field are based on ground conditions, heating, and cooling requirements of the application and system design.

Vertical ground loop

This system is used in vertical borehole applications. This design is well suited for retrofit applications when space is limited or where landscaping is already complete and minimum disruption of the site is desired. The vertical ground loop system contains a single loop of pipe inserted into a

hole. The hole is back-filled and grouted after the pipe is inserted. The completed loop is concealed below ground. The number of loops required depends on ground conditions, heating and cooling requirements, and the depth of each hole.

Hybrid systems

In some applications, it may be beneficial to incorporate a cooling tower into the ground loop system to reduce the overall cost. A hybrid system discards excess heat into the air and increases the cooling performance of the ground loop.

Condensate drainage

Venting

Condensate lines should be properly vented to prevent fan pressure from causing water to hang up in the piping. Condensate lines should be pitched to assure full drainage of condensate under all load conditions. Chemical treatment should be provided to remove algae in the condensate pans and drains in geographical areas that are conducive to algae growth.

Trapping

Condensate trapping is an essential necessity on every water source heat pump unit. A trap is provided to prevent the back flow of moisture from the condensate pan and into the fan intake or downstream into the mechanical system. The water seal or the length of the trap depends on the positive or negative pressure on the drain pan. As a rule of thumb, the water seal should be sized at 1 in. for every 1 in. of negative pressure on the unit. The water seal is the distance from the bottom of the unit condensate piping connection to the bottom of the condensate drain line run-out piping. Therefore, the trap size should be double the water seal dimension.

Each unit must be installed with its own individual trap, vent, and means to flush or blow out the condensate drain lines. Do not install units with a common trap or vent.

Hot gas reheat

Hot gas reheat (HGR) allows the user to control not only space temperature, but also humidity levels within the conditioned space. Excessive moisture in the space can promote mold growth leading to damage in the structure or interior surfaces, as well as reducing the air quality and creating an unhealthy environment.

Excess humidity may be caused by the unit having to operate under a widely varying load, an oversized short cycling unit, a high percentage of unconditioned outside air being introduced into the space, a high latent load in the space and any location where humidity infiltration is a problem.

Typical unit control is by a wall mounted thermostat that senses temperature in the occupied space. By using a humidistat, in addition to the thermostat, we are able to monitor the humidity levels in the space. The HGR option allows cooling and dehumidification to satisfy both the thermostat and humidistat while preventing over cooling of the space while in the dehumidification mode.

Once the thermostat reaches set point temperature and the humidity is above set point, the unit controller will energize the reheat valve, operating the unit in hot gas reheat mode. First it cools and dehumidifies, then reheats the air using hot refrigerant gas before delivering it to the space — usually 2 to 5°F below room temperature. The unit is now operating as a dehumidifier. By reheating the

air along a constant sensible heat line, the relative humidity of the leaving air is reduced.

The moisture removal capacity of a specific heat pump is determined by the unit latent capacity rating. A heat pump's latent capacity can be determined by reviewing the heat pump specification data sheets. Depending upon the entering water and air conditions, a total and sensible capacity can be interpolated from the data sheets. Subtracting sensible capacity from total capacity by 1069 (Btu/lb of water vapor at 80°F db and 67°F wb) yields the amount of moisture removal in pounds per hour.

Sequence of operation (on/off control)

The sequence of operation in the cooling and heating mode is the same as a regular heat pump. In the reheat mode, on a call from the humidistat, the reheat relay coils are energized through the "H" circuit. The cooling relay remains de-energized, enabling the reheat solenoid. The blower relay, reversing valve and compressor contactor are energized through contacts on the reheat relay. Should the temperature in the space increase above the set point, compressor terminal Y is energized. This will de-energize the reheat valve, putting the unit into straight cooling mode. A call for cooling or heating will always take precedence over hot gas reheat.

Control options

There are several ways to control heat pumps with hot gas reheat. You should choose the means that best suits your specific application. Most heat pump compatible thermostats, in conjunction with a humidistat are acceptable for use. (Note: "O" output for reversing valve energized in cooling mode is required.) Combination thermostat/humidistat is also available.

Water conditioning

In some applications, maintaining proper water quality may require the use of higher corrosion protection for the water-to-refrigerant heat exchanger. Water quality varies from location to location and is unique for each job. Water characteristics such as pH value, alkalinity, hardness, and specific conductance are of importance when considering any WSHP application. Water typically includes impurities and hardness that must be removed. The required treatment will depend on the water quality, as well as the type of system. Water problems fall into three main categories:

1. Scale formation caused by hard water reduces the heat transfer rate and increases the water pressure drop through the heat exchanger. As water is heated, minerals and salts are precipitated from a solution and deposited on the inside surface of the pipe or tube.
2. Corrosion is caused by absorption of gases from the air coupled with water on exposed metal. Corrosion is also common in salt-water areas.
3. Organic growths such as algae can reduce the heat transfer rate by forming an insulating coating on the inside tube surface. Algae can also promote corrosion by pitting.

NOTE: In most commercial water loop applications, Aquazone™ WSHP units use a copper, water-to-refrigerant heat exchanger. Units should be equipped with a cupronickel heat exchanger for applications where water is outside the standard contaminant limits for a copper heat exchanger.

Water Quality Guidelines

CONDITION	HX MATERIAL ^a	CLOSED RECIRCULATING ^b	OPEN LOOP AND RECIRCULATING WELL ^c		
Scaling Potential — Primary Measurement					
Above the given limits, scaling is likely to occur. Scaling indexes should be calculated using the limits below.					
pH/Calcium Hardness Method	All	N/A	pH < 7.5 and Ca Hardness, <100 ppm		
Index Limits for Probable Scaling Situations (Operation outside these limits is not recommended.)					
Scaling indexes should be calculated at 150°F for direct use and HWG applications, and at 90°F for indirect HX use. A monitoring plan should be implemented.					
Ryznar Stability Index	All	N/A	6.0 - 7.5 If >7.5 minimize steel pipe use.		
Langelier Saturation Index	All	N/A	-0.5 to +0.5 If <-0.5 minimize steel pipe use. Based upon 150°F HWG and direct well, 85°F indirect well HX.		
Iron Fouling					
Iron Fe ²⁺ (Ferrous) (Bacterial Iron Potential)	All	N/A	<0.2 ppm (Ferrous) If Fe ²⁺ (ferrous) >0.2 ppm with pH 6 - 8, O ₂ <5 ppm check for iron bacteria.		
Iron Fouling	All	N/A	<0.5 ppm of Oxygen Above this level deposition will occur.		
Corrosion Prevention^d					
pH	All	6 - 8.5 Monitor/treat as needed.	6 - 8.5 Minimize steel pipe below 7 and no open tanks with pH <8.		
Hydrogen Sulfide (H ₂ S)	All	N/A	<0.5 ppm At H ₂ S>0.2 ppm, avoid use of copper and cupronickel piping or HXs. Rotten egg smell appears at 0.5 ppm level. Copper alloy (bronze or brass) cast components are okay to <0.5 ppm.		
Ammonia Ion as Hydroxide, Chloride, Nitrate and Sulfate Compounds	All	N/A	<0.5 ppm		
Maximum Chloride Levels	Copper Cupronickel 304 SS 316 SS Titanium	N/A N/A N/A N/A N/A	Maximum allowable at maximum water temperature.		
			50°F (10°C)	75°F (24°C)	100°F (38°C)
			<20 ppm	NR	NR
			<150 ppm	NR	NR
			<400 ppm	<250 ppm	<150 ppm
<1000 ppm	<550 ppm	<375 ppm			
>1000 ppm	>550 ppm	>375 ppm			
Erosion and Clogging					
Particulate Size and Erosion	All	<10 ppm of particles and a maximum velocity of 6 fps. Filtered for maximum 800 micron size.	<10 ppm (<1 ppm "sandfree" for reinjection) of particles and a maximum velocity of 6 fps. Filtered for maximum 800 micron size. Any particulate that is not removed can potentially clog components.		
Brackish	All	N/A	Use cupronickel heat exchanger when concentrations of calcium or sodium chloride are greater than 125 ppm are present. (Seawater is approximately 25,000 ppm.)		

NOTE(S):

- Heat exchanger materials considered are copper, cupronickel, 304 SS (stainless steel), 316 SS, titanium.
- Closed recirculating system is identified by a closed pressurized piping system.
- Recirculating open wells should observe the open recirculating design considerations.
- If the concentration of these corrosives exceeds the maximum allowable level, then the potential for serious corrosion problems exists. Sulfides in the water quickly oxidize when exposed to air, requiring that no agitation occur as the sample is taken. Unless tested immediately at the site, the sample will require stabilization with a few drops of one Molar zinc acetate solution, allowing accurate sulfide determination up to 24 hours after sampling. A low pH and high alkalinity can cause system problems, even when both values are within ranges shown. The term pH refers to the acidity, basicity, or neutrality of the water supply. Below 7.0, the water is considered to be acidic. Above 7.0, water is considered to be basic. Neutral water registers a pH of 7.0. To convert ppm to grains per gallon, divide by 17. Hardness in mg/l is equivalent to ppm.

LEGEND

- HWG** — Hot Water Generator
- HX** — Heat Exchanger
- N/A** — Design Limits Not Applicable Considering Recirculating Potable Water
- NR** — Application Not Recommended
- SS** — Stainless Steel

Acoustical design

Sound power levels represent the sound as it is produced by the source, the WSHP unit, with no regard to attenuation between the source and the space. Acoustical design goals are necessary to provide criteria for occupied spaces where people can be comfortable and communicate effectively over the background noise of the air-conditioning system and other background noise sources.

Acoustical design goals are desirable sound pressure levels within a given conditioned space and are represented by noise criteria (NC) curves. Noise criteria curve levels represent a peak over a full spectrum of frequencies. A high value in a low frequency band has the same effect on NC level as a lower value in a high frequency band. It is important that sound levels be balanced over the entire spectrum relative to the NC curve. The lower the NC criteria curve, the more stringent the room acoustical design must be to meet the design goals.

It is important to know how to convert NC levels from the unit ratings in terms of sound power (Lw). This conversion depends on the specifics of the acoustical environment of the installation.

The resulting calculations are compared to the NC curve selected for the area to assess the acoustical design.

Some of the factors that affect conversion of sound power to sound pressure and consequent NC levels include:

- Type of acoustical ceiling
- Use of metal or flex duct
- Absorption in the occupied space
- Location in the occupied space
- Open or closed layout plan
- Use of open or ducted returns
- Orientation of unit to occupant
- Use of lined or unlined duct

Octave Band Sound Pressure Level (Lp) Associated with NC Curves

NOISE CRITERIA CURVES	OCTAVE BAND SOUND PRESSURE LEVEL (Lp)							
	Frequency (Hz)							
	63	125	250	500	1000	2000	4000	8000
NC-15	49	36	26	17	17	14	12	11
NC-20	52	41	33	27	22	19	17	16
NC-25	54	45	38	31	27	24	22	21
NC-30	58	49	41	36	31	29	28	27
NC-35	61	53	45	40	36	34	33	32
NC-40	64	57	50	45	41	39	38	37
NC-45	67	61	54	49	46	44	43	42
NC-50	71	64	58	54	51	49	48	47
NC-55	74	68	63	58	56	54	53	52
NC-60	77	71	67	63	61	59	58	57
NC-65	80	75	71	68	66	64	63	62

WSHP sound control

The analysis of the projected sound level in the conditioned space caused by a WSHP unit located in a ceiling plenum is quite involved. The key is to have good sound power ratings (Lw) in dB on the equipment to determine the sound attenuation effect of the ductwork, ceiling and room. In combination with using standard Aquazone™ equipment attenuating features or the advanced mute package

features, suggestions for unit sound design are provided to design around the WSHP units.

Use the following guidelines for layout of Aquazone™ WSHP units to minimize noise:

1. Obtain sound power ratings in accordance with latest standards from manufacturers to select quietest equipment.
2. Do not locate units over a space with a required NC of 40 or less. Instead, locate units above less sensitive noise areas such as: above or in equipment rooms, utility closets, rest rooms, storage rooms, or above corridors.
3. Provide at least 10 feet between WSHP units to avoid the additive effect of two noise sources.
4. Provide an acoustical pad underneath the WSHP unit in applications where the unit must be mounted above noise sensitive areas such as private offices or conference rooms. The pad attenuates radiated noise. Be sure the pad has an area at least twice that of the WSHP footprint.
5. Maximize the installed height above the suspended ceiling.
6. Be sure the WSHP unit is located at least 6 feet away from any ceiling return grille to prevent line-of-sight casing noise to reach the space below.
7. Suspend the WSHP unit from the ceiling with hangers that use spring or neoprene type isolators to reduce vibration transmission.
8. Use flexible electrical connections to the WSHP unit. **DO NOT USE RIGID CONNECTIONS.**
9. Use flexible loop water and condensate piping connections to the WSHP unit.
10. Use a canvas duct connector to connect the WSHP discharge to the downstream duct system. This reduces vibration-induced noise.
11. Provide acoustic interior lining for the first 20 feet of discharge duct, or until the first elbow is reached. The elbow prevents line-of-sight sound transmission in the discharge duct.
12. Provide turning vanes in ductwork elbows and tees to reduce air turbulence.
13. Size the sheet metal supply duct with velocities no greater than 1000 fpm.
14. Ensure ductwork is rigid.
15. Use round duct whenever possible to further reduce noise.
16. Allow at least 3 equivalent duct diameters of straight duct upstream and downstream of the unit before allowing any fittings, transitions, etc.
17. Seal all penetrations around duct entering the space.
18. Provide a 4-ft run-out duct made of flexible material to connect a diffuser to the supply trunk duct. The flex duct provides an “attenuating end-effect” and reduces duct-transmitted sound before it reaches the space. Typically a 6 dB sound reduction can be accomplished with the use of flex duct.

19. Locate the run-out duct balancing damper as far away from the outlet diffuser as possible. Locating the balancing damper at the trunk duct exit is the best location.
20. If return air is drawn through a ceiling plenum, provide an acoustically lined return duct elbow or “L” shaped boot at the WSHP to eliminate line-of-sight noise into the ceiling cavity and possible through ceiling return air grilles. Face the elbow or boot away from the nearest adjacent WSHP unit to prevent additive noise.
21. Do not hang suspended ceiling from the ductwork.

If installing unit in small equipment rooms or closets, the following additional guidelines apply:

1. Mount the unit on a pad made of high-density sound absorbing material such as rubber or cork. Extend the pad beyond the WSHP unit footprint by at least 6 inches in each direction.
2. Since the unit returns airflow through a grille mounted in a closet door, provide a sound barrier or some other modification of the closet to prevent line-of-site noise into the space.
3. Follow good duct design practice in sizing and locating the connection of the WSHP discharge to the supply duct system. Use an elbow with turning vanes and bent in the direction of the fan rotation to minimize turbulence. Make any duct transitions as smooth and as gradual as possible to again minimize turbulence and loss of fan static pressure.

Operating Limits

AIR LIMITS	STANDARD UNIT	EXTENDED RANGE OPTION
COOLING		
Minimum Cooling Entering Air db/wb °F	68/57	68/57
Maximum Cooling Entering Air db/wb °F	95/85	95/85
Minimum Cooling Entering Fluid Temp. °F	70	50
Water Loop Typical Coil Entering Fluid Range Temperature °F	70/90	70/90
Maximum Cooling Entering Fluid Temperature °F	110	110
HEATING		
Minimum Heating Entering Air db °F	50	50
Maximum Heating Entering Air db °F	80	80
Normal Water Coil Entering Fluid Range °F	50-80	25-80 ^a
Minimum Water Coil Entering Fluid °F	50	25 ^a

NOTE(S):

- a. Antifreeze solution is required at these fluid temperatures.

LEGEND

- DB** — Dry Bulb
WB — Wet Bulb

Freeze Protection

Applications where systems are exposed to outdoor temperatures below freezing (32°F) must be protected from freezing. The most common method of protecting water systems from freezing is adding glycol concentrations into the water. Design care should be used when selecting both the type and concentrations of glycol used due to the following:

- Equipment and performance may suffer with high concentrations of glycol and other antifreeze solutions.
- Loss of piping pressure may increase greatly, resulting in higher pumping costs.
- Higher viscosity of the mixture may cause excess corrosion and wear on the entire system.
- Acidity of the water may be greatly increased, promoting corrosion.
- Glycol promotes galvanic corrosion in systems of dissimilar metals. The result is corrosion of one metal by the other, causing leaks.

The WSHP Open multi-protocol controller will control mechanical cooling, heating, hot gas reheat and waterside economizer outputs based on its own space temperature input and set points. An optional CO₂ IAQ (indoor air quality) sensor mounted in the space can maximize the occupant comfort. The WSHP Open controller has its own hardware clock that is automatically set when the heat pump software is downloaded to the board. Occupancy types are described in the scheduling section below. The following sections describe the functionality of the WSHP Open multi-protocol controller. All point objects that are referred to in this sequence of operation will be referenced to the objects as viewed in the BACview⁶ handheld user interface.

Scheduling

Scheduling is used to start/stop the unit based upon a time period to control the space temperature to specified occupied heating and cooling set points. The controller is defaulted to control by occupied set points all the time, until either a Time Schedule is configured with the Equipment Touch™ interface, i-Vu® Open, or a third party control system Enables/Disables the BAS On/Off point. Your local time and date must be set for these functions to operate properly. The occupancy source can be changed to one of the following:

Occupancy schedules

The controller will be occupied 24/7 until a Time schedule has been configured using either i-Vu Open, Equipment Touch or a third party control system Enables/Disables the BAS On/Off point. This can be disabled by going to Config>Unit>Occupancy Schedules and changing the point from Enable to Disable.

NOTE: This point must be Enabled in order for i-Vu Open or Bacview⁶ to assign a Time schedule to the controller.

Schedule

The unit will operate according to the schedule configured and stored in the unit. The schedule is accessible via the Equipment Touch user interface, i-Vu Open, or Field Assistant. The daily schedule consists of a start/stop time (standard or 24 hour mode) and seven days of the week, starting with Monday and ending on Sunday.

Occupancy input contact (option)

If configured for remote occupancy control (default), the WSHP Open controller has the capability to use an external dry contact closure to determine the occupancy status of the unit. You will need to disable the Occupancy Schedules in order to utilize the Occupancy Contact Input. The control will cause the unit to go into an occupied mode whenever the abnormal input is sensed. After the input returns to its normal state, the unit will stay in the occupied mode for the configured Occupancy Override Delay period (15 minutes default).

NOTE: Scheduling can only be controlled from one source.

BAS (building automation system) on/off

For use with a building automation system that supports network scheduling, you will need to disable the Occupancy Schedules so the BAS system can control the unit through a network communication and the BAS scheduling function.

NOTE: Scheduling can only be controlled from one source.

Global occupancy scheduling

The WSHP Open controller has the capability to read the occupancy status from another unit so that a group of

WSHPs can be controlled from a single occupancy schedule. The local Occupancy Schedules must be disabled in order to utilize the global occupancy input.

NOTE: Scheduling can only be controlled from one source.

BACnet network occupancy input

The WSHP Open controller has the capability to accept an external BACnet Binary Network Input for occupancy control. This function is only compatible with units used in BACnet systems. You will need to configure the “System Occupancy” BACnet network input point to locate the device and point name where the external occupancy point information resides. Also Occupancy Schedules must be disabled in order to utilize this input.

NOTE: Scheduling can only be controlled from one source.

Fire/smoke detector (FSD) input (field optional)

The WSHP Open controller has the capability to read the status of a normally closed FSD contact input to determine if a fire or smoke detector alarm is present. If the controller determines an alarm condition is present, all heating, cooling and the fan are disabled. The normal state of the switch is factory set to Normally Closed and cannot be changed.

Shutdown input

The WSHP Open controller has a shutdown input (software) which when set to its Active mode will cause the WSHP to safely shut down in a controlled fashion. Heating and cooling will be disabled after any minimum runtime conditions expire and the fan will be disabled after the fan off timer expires. All alarms are reset but any active alarm will remain active. After the shutdown input transitions from Active mode to Inactive mode, the WSHP Open controller will restart after the configured power fail restart delay expires.

Indoor fan

The indoor fan will operate in any one of three modes depending upon the user configuration selected. Fan mode can be defined/selected as Auto, Continuous, or Always On. In Auto mode the fan is in intermittent operation during both occupied and unoccupied periods. Continuous fan is intermittent during unoccupied periods and continuous during occupied periods. Always On operates the fan continuously during both occupied and unoccupied periods. In the default mode, Continuous, the fan will be turned on whenever any one of the following is true:

- It is in occupied mode. Determined by its occupancy status.
- Whenever there is a demand for cooling or heating in the unoccupied mode.
- When there is a call for dehumidification (optional).

When power is re-applied after a power outage, there will be a configured time delay of 5 to 600 seconds before starting the fan. There are also configured fan delays for Fan On and Fan Off. The fan on delay defines the delay time (0 to 30 seconds; default 10) before the fan begins to operate after heating or cooling is started while the fan off delay defines the delay time (0 to 180 seconds; default 45) the fan will continue to operate after heating or cooling is stopped. The fan will continue to run as long as the compressors, heating stages, or the dehumidification relays are

on. If the SPT failure alarm or condensate overflow alarm is active; the fan will be shut down immediately regardless of occupancy state or demand.

Automatic 3-speed fan control

The WSHP Open controller is capable of controlling up to three fan speeds. The motor will operate at the lowest speed possible to provide quiet and efficient fan operation with the best latent capability. The motor will increase speed if additional cooling or heating is required to obtain the desired space temperature set point. The control increases the motor's speed as the space temperature rises above the cooling or below the heating set point. The amount of space temperature increase above or below the set point required to increase the fan speed is user configurable in the set point. Also, the control will increase the fan speed as the supply-air temperature approaches the configured minimum or maximum limits. On the 50HQP and 50VQP units, the factory-installed VFD option is required for automatic fan speed control and can be configured for 2 or 3 speed operation.

Fan speed control - during heating

Whenever heat is required and active, the control continuously monitors the supply air temperature to verify it does not rise above the configured Maximum Heating SAT Limit (110°F default). As the SAT approaches this value, the control will increase the fan speed as required to ensure the SAT will remain 5°F below the limit. This feature provides the most quiet and efficient operation by operating the fan at the lowest speed possible.

Fan speed control - during cooling

Whenever mechanical cooling is required and active, the control continuously monitors the supply-air temperature to verify it does not fall below the configured Minimum Cooling SAT Limit (50°F default). As the SAT approaches this value, the control will increase the fan speed as required to ensure the SAT will remain 5°F above the limit. Fan will operate at lowest speed to maximize latent capacity during cooling.

Fan status (option)

An optional input can be configured as either an occupancy input contact or a fan status input. If configured as fan status, the controller will compare the status of the fan to the desired commanded state. Whenever the fan is commanded to run (ON), the fan status will be checked and verified to match the commanded state. If the fan status is not on, then a fan status alarm will be generated after 1 minute and the equipment's compressor(s) and auxiliary heat will be disabled and the optional OA (outdoor air) damper will close (if equipped).

Cooling

The WSHP Open controller will operate one or two stages of compression to maintain the desired cooling set point. The compressor outputs are controlled by the PI (proportional-integral) cooling loop and cooling stages capacity algorithm. They will be used to calculate the desired number of stages needed to satisfy the space by comparing the space temperature (SPT) to the appropriate cooling set point. The waterside economizer, if applicable, will be used for first stage cooling in addition to the compressor(s).

The following conditions must be true in order for the cooling algorithm to run:

- Cooling is set to Enable.
- The Fire/Smoke Input and Shutdown modes are inactive.
- Heat mode is not active and the compressor time guard(s) have expired.
- Condensate Overflow input is Normal.
- Fan Status is true (if option is enabled).
- If occupied, the SPT is greater than the occupied cooling set point.
- Space temperature reading is valid
- If unoccupied, the SPT is greater than the unoccupied cooling set point.
- If economizer cooling is available and active and the economizer alone is insufficient to provide enough cooling.
- OAT is greater than the cooling lockout temperature if OAT is available.
- Condenser water pump is on (if condenser water linkage active).

If all the above conditions are met, the compressors will be energized as required, otherwise they will be de-energized. If cooling is active and should the SAT approach the minimum SAT limit, the fan will be indexed to the next higher speed. Should this be insufficient and if the SAT falls further (equal to the minimum SAT limit), the fan will be indexed to the maximum speed. If the SAT still continues to fall 5°F below the minimum SAT limit, all cooling stages will be disabled.

During cooling, the reversing valve output will be held in the cooling position (either B or O type as configured) even after the compressor is stopped. The valve will not switch position until the heating mode is required.

The configuration screens contain the Min SAT parameter as well as cooling lockout based on outdoor air temperature (OAT), both can be adjusted to meet various specifications.

There is a 5-minute off time for the compressor as well as a 5-minute time delay when staging up to allow the SAT to achieve a stable temperature before energizing a second stage of capacity. Likewise, a 45-second delay is used when staging down.

After a compressor is staged off, it may be restarted again after a normal time-guard period of 5 minutes and if the supply air temperature has increased above the minimum supply air temperature limit.

The WSHP Open controller provides a status input to monitor the compressor operation. The status is monitored to determine if the compressor status matches the commanded state. This input is used to determine if a refrigerant safety switch or other safety device has tripped and caused the compressor to stop operating normally. If this should occur, an alarm will be generated to indicate the faulted compressor condition.

Reverse cycle heating

The WSHP Open controller will operate one or two stages of compression to maintain the desired heating set point. The compressor outputs are controlled by the heating PI (proportional-integral) loop and heating stages capacity algorithm. They will be used to calculate the desired number of stages needed to satisfy the space by comparing the

space temperature (SPT) to the appropriate heating set point.

The following conditions must be true in order for the heating algorithm to run:

- Heating is set to Enable.
- The Fire/Smoke Input and Shutdown modes are inactive.
- Cool mode is not active and the compressor time guard has expired.
- Condensate Overflow input is Normal.
- Fan Status is true (if option is enabled).
- If occupied, the SPT is less than the occupied heating set point.
- Space temperature reading is valid.
- If unoccupied, the SPT is less than the unoccupied heating set point.
- OAT is less than the heating lockout temperature if OAT is available.
- Condenser water pump is on (if condenser water linkage active).

If all the above conditions are met, the heating outputs will be energized as required, otherwise they will be de-energized. If the heating is active and should the SAT approach the maximum SAT limit, the fan will be indexed to the next higher speed. Should this be insufficient, then if the SAT rises further and reaches the maximum heating SAT limit, the fan will be indexed to the maximum speed. If the SAT still continues to rise 5°F above the maximum limit, all heating stages will be disabled.

During heating, the reversing valve output will be held in the heating position (either B or O type as configured) even after the compressor is stopped. The valve will not switch position until the cooling mode is required.

The configuration screens contain the Max SAT parameter as well as heating lockout based on outdoor air temperature (OAT), both can be adjusted to meet various specifications.

There is a 5-minute off time for the compressor as well as a 5-minute time delay when staging up to allow the SAT to achieve a stable temperature before energizing a second stage of capacity. Likewise, a 45-second delay is used when staging down.

After a compressor is staged off, it may be restarted again after a normal time-guard period of 5 minutes and if the supply air temperature has fallen below the maximum supply air temperature limit.

The WSHP Open controller provides a status input to monitor the compressor operation. The status is monitored to determine if the compressor status matches the commanded state. This input is used to determine if a refrigerant safety switch or other safety device has tripped and caused the compressor to stop operating normally. If this should occur, an alarm will be generated to indicate the faulted compressor condition. Also, if auxiliary heat is available (see below), the auxiliary heat will operate to replace the reverse cycle heating and maintain the space temperature as required.

Auxiliary heat

Single-stage electric auxiliary heat

The control can operate a single stage of electric heat installed on the discharge side of the unit in order to maintain the desired heating set point should the compressor

capacity be insufficient or a compressor failure occurs. Unless a compressor fault condition exists, the heat stage will only operate to supplement the heat provided by the compressor if the space temperature falls more than one degree below the desired heating set point. The heat stage will be controlled so the SAT will not exceed the Maximum Heating SAT limit and subject to a 2-minute minimum OFF time to prevent excessive cycling. Should the compressor(s) fail to operate and heating is required, the auxiliary heat will operate as required to maintain the space temperature set point.

Indoor air quality (IAQ) and demand controlled ventilation (DCV)

If the optional indoor air quality sensor is installed or the network input point "System Space AQ" is utilized, the WSHP Open controller can maintain indoor air quality, with a field-installed modulating OA damper providing demand controlled ventilation. The control operates the modulating OA damper during occupied periods. The control monitors the CO₂ level and compares it to the configured set points and adjusts the ventilation rate as required. The control provides proportional ventilation to meet the requirements of ASHRAE specifications by providing a base ventilation rate and then increasing the rate as the CO₂ level increases. The control will begin to proportionally increase ventilation when the CO₂ level rises above the start ventilation set point and will reach the full ventilation rate when the CO₂ level is at or above the maximum set point. A user configurable minimum damper position ensures that proper base ventilation is delivered when occupants are not present. The IAQ configurations can be accessed through the configuration screen. The following conditions must be true in order for this algorithm to run:

- Damper control is configured for DCV.
- The Fire/Smoke Input and Shutdown modes are inactive.
- Fan Status is true (if option is enabled).
- The unit is in an occupied mode.
- IAQ sensor reading is greater than the DCV Start Control set point.

The control has four user adjustable set points: DCV start control set point, DCV Maximum Control set point, Minimum damper position and the DCV Maximum damper position.

NOTE: In order for the damper to maintain proper base ventilation, the fan must be configured to operate in either the Continuous or Always On mode.

Two-position OA damper

The control can be configured to operate as a ventilation damper in a 2-position ventilation mode to provide the minimum ventilation requirements during occupied periods. This control operation still utilizes the modulating damper actuator.

Dehumidification with hot gas reheat (HGRH)

The WSHP Open controller will provide occupied and unoccupied dehumidification only on units that are equipped with the factory-installed HGRH option. This function requires an accessory space relative humidity sensor. When using a relative humidity sensor to control dehumidification during occupied or unoccupied times, the dehumidification set points are used accordingly. Additionally, the network input point "System Space RH" may also

be used in place of the hard wired RH (relative humidity) sensor. When the indoor relative humidity becomes greater than the dehumidification set point a dehumidification demand will be acknowledged. As long as heating or cooling is not currently active, dehumidification will be energized, bringing on the supply fan (medium speed), mechanical cooling, and the integral refrigerant hot gas reheat coil. The controls will engage cooling mode, start the compressor if not already operating, and waste heat from the compressor cooling cycle will be diverted to the reheat coil. The reversing valve will be positioned to operate the compressor in the cooling mode. If a call for sensible cooling takes place during hot gas reheat operation, the hot gas reheat is de-energized and the reheat operation is turned off. Once the call for cooling has been satisfied and if there is still a need for dehumidification, the unit will continue to operate in a dehumidification mode with the compressor providing cooling and the refrigerant reheat energized.

Waterside economizer

The WSHP Open controller has the capability of providing two-position waterside economizer operation (economizer coil is mounted to the entering air side of the unit and connected to the condenser water loop) in order to be used to provide free cooling (or preheating) when water conditions are optimal. Water economizer settings can be accessed through the equipment status screen. The following conditions must be true for economizer operation:

- SAT reading is available.
- EWT reading is available.
- If occupied, the SPT is greater than the occupied cooling set point or less than the occupied heating set point and the condenser water temperature is suitable.
- Space temperature reading is valid.
- If unoccupied, the SPT is greater than the unoccupied cooling set point or less than the unoccupied heating set point and the condenser water temperature is suitable.

Two-position water economizer control

The control has the capability to control a normally open or normally closed, two-position water valve to control condenser water flow through a coil on the entering air side of the unit.

Cooling

The purpose is to provide a cooling economizer function directly from the condenser water loop when the entering water loop temperature is suitable (at least 5°F below space temperature). If the optional coil is provided and the water loop conditions are suitable, then the valve will open to provide cooling to the space when required. Should the capacity be insufficient for a period greater than 5 minutes, or should a high humidity condition occur, then the compressor will be started to satisfy the load. Should the SAT reach the Minimum Cooling SAT limit, the economizer valve will close during compressor operation.

Heating

Additionally, the economizer control will open the water valve should the entering water loop temperature be suitable for heating (at least 5°F above space temperature) and heat is required. The valve will be controlled in a similar manner except to satisfy the heating requirement. Should the coil capacity be insufficient to satisfy the space load for more than 5 minutes, then the compressor will be started to satisfy the load. Should the SAT reach the Maximum

Heating SAT limit, the economizer valve will close during compressor operation.

Demand limit

The WSHP Open controller has the ability to accept three levels of demand limit from the BACnet network. In response to a demand limit, the unit will decrease its heating set point and increase its cooling set point to widen the range in order to immediately lower the electrical demand. The amount of temperature adjustment in response is user adjustable for both heating and cooling and for each demand level. The response to a particular demand level may also be set to zero.

Power failure restart delay

The control provides a user configurable delay when recovering from a power failure or SHUTDOWN mode or when transitioning from unoccupied to occupied mode in order to prevent excessive demand when many units start simultaneously. Each unit can be user configured for a unique delay between 5 and 600 seconds. The factory programmed default delay is 180 seconds.

Fire/smoke detector alarm

The control monitors the voltage input to J1-9 to detect if a smoke detector or fire detector Normally Closed contact has opened, indicating an alarm condition. The control will verify the presence of 24 vac on this input. If the input should open at any time, an alarm will be generated after 3 seconds and the equipment (fan, compressor, auxiliary heat and damper) will immediately return to an OFF or closed state.

Space temperature alarms

The control provides the ability to generate an alarm whenever the space temperature exceeds the alarm set point. A separate occupied hysteresis and fixed unoccupied high and low alarm set points are provided. The control provides a 5-minute alarm delay during unoccupied periods. During occupied periods, the control uses the occupied temperature set points and applies the hysteresis value to determine the alarm set points. Whenever an occupancy transition from unoccupied to occupied occurs or the occupied temperature set points are changed causing an alarm condition to occur, the control will automatically calculate an alarm delay (equivalent to the configured delay time in minutes per degree F times the temperature error that occurred plus 15 minutes). This will prevent nuisance alarms whenever an occupancy change occurs and allows time for the unit to correct an alarming temperature condition.

Condenser water temperature alarm

The control has 4 configurable alarm limits for condenser water temperature. The control will verify that the water temperature is within operating range (between high and low limits) for the specific operating mode (heating or cooling) before energizing the compressor. Once the compressor is started, the condenser water temperature is further monitored to verify that it is within limits to ensure sufficient water is flowing through the coil. Should the leaving water temperature rise above or fall below the appropriate limits, an alarm is generated and the compressor will be shut down if the condition occurs for more than 15 seconds.

Supply air temperature alarm

The control has 2 configurable alarm limits for supply air temperature. The control will verify that the supply air tem-

perature is within operating range (between high and low limits) whenever the compressor or auxiliary heat is operating. Should the air temperature rise above or fall below the appropriate limit, an alarm is generated if the condition occurs for more than 1 minute.

High condensate/overflow alarm

The control will monitor a discrete input to determine the state of a condensate level switch. The input can be configured to alarm on either an open or closed switch condition. Should this input be in an alarm state, the control will start a timer and after the timer exceeds a configurable Condensate Overflow Alarm Delay limit (10-second default), the control will generate an alarm and the unit will disable the compressor and fan outputs.

Fan status alarm (optional)

The control generates a fan status alarm should the fan status input detect the fan is OFF after any fan speed output has been enabled. A 30-second alarm delay is used to allow the fan sufficient time to start operating before an alarm condition is detected. The control monitors the fan output and if the fan is operating at any speed, the fan status must detect the fan is operating.

Compressor status alarm

The control generates a compressor failure alarm should the compressor status input detect the compressor is OFF after the compressor output has been energized. A 6-minute alarm delay is used to allow the compressor to start (prevents alarms due to time guard operation) before an alarm condition is detected. The control monitors the compressor output and if the compressor output is energized, the compressor status input must detect the compressor operation.

Filter status alarm

The control provides the ability to generate a dirty filter alarm after the number of fan run hours exceeds a configurable filter alarm timer limit. The control monitors the fan output and if the fan is operating at any speed, it accumulates run time. Should the fan run time hours exceed the configurable limit, an alarm is generated. To reset the alarm timer after the alarm has been generated, a Reset Filter Alarm input is provided. The filter alarm can be disabled by setting the Filter Alarm Timer Delay to zero (factory default).

Indoor air quality alarm

The control provides the ability to generate a high CO₂ level alarm during occupied periods whenever the CO₂ sensor value exceeds the user adjustable limit. Whenever an occupancy transition from unoccupied to occupied occurs, or the occupied alarm limit is changed to a value that causes an alarm condition to occur, the control will automatically calculate an alarm delay:

$$\frac{\text{the configured delay time in minutes}}{\text{ppm times the error that occurred}} + 15 \text{ minutes}$$

This prevents nuisance alarms from occurring when occupancy changes or the set point is changed. The IAQ alarm can be disabled by setting Occupied High IAQ Alarm Limit to zero.

Relative humidity alarm

The control provides the ability to generate an alarm whenever the space relative humidity exceeds the alarm set point. Separate occupied and unoccupied high humidity alarm set points are provided. The control provides a 5-minute alarm delay during unoccupied periods. During occupied periods, the controller uses the occupied high RH alarm limit. Whenever an occupancy transition from unoccupied to occupied occurs, or the occupied high alarm limit is lowered causing an alarm condition to occur, the control will automatically calculate an alarm delay:

$$\frac{\text{the configured delay time in minutes}}{\% \text{ RH times the humidity error condition that occurred}} + 15 \text{ minutes}$$

This will prevent nuisance alarms whenever an occupancy change occurs and allows time for the unit to correct an alarming humidity condition.

Condenser water linkage failure alarm (if condenser water linkage was active)

The control generates a condenser water linkage failure alarm should linkage fail after once being active. The linkage status is monitored and should it fail to be updated from the loop controller, then a Condenser Water Linkage alarm is generated. A 6-minute alarm delay is provided to prevent false alarms from occurring.

NOTE: This alarm can only be reset by re-establishing linkage and correcting the condition that caused the linkage failure to occur or by setting the SHUTDOWN point to Active momentarily.

Airside linkage failure alarm (if airside linkage was active)

The control generates an airside linkage failure alarm should linkage fail after once being active. The linkage status is monitored and should it fail to be updated from the Master Zone Controller, then an Airside Linkage alarm is generated. A 6-minute alarm delay is provided to prevent false alarms from occurring.

NOTE: This alarm can only be reset by re-establishing linkage and correcting the condition that caused the linkage failure to occur or by setting the SHUTDOWN point to Active momentarily.

OAT sensor alarm (if network OA temperature was active)

The control generates an OAT sensor failure alarm should the value of OAT fail to be updated through the network after once being active. The update status is monitored and should it fail to be updated, then an OAT sensor alarm is generated. An alarm delay (approximately 1 hour) is provided to prevent false alarms from occurring while minimizing the required update rate for OAT.

NOTE: This alarm can be reset by setting the SHUTDOWN point to Active momentarily.

ZS sensor alarm (if ZS sensor was active)

The control generates a ZS sensor failure alarm should the ZS sensor fail to communicate with the control. The update status is monitored and should it fail to be updated, then the alarm is generated.

Commercial Water Source Heat Pump Units with Puron® Refrigerant (R-410A)

HVAC Guide Specifications

Size Range: **HQP 72,000 to 242,000 Btuh Cooling Capacity**

VQP 72,000 to 360,000 Btuh Cooling Capacity

Carrier Model Number: **50HQP,VQP**

Part 1 — General

1.01 SYSTEM DESCRIPTION

- A. Units shall be designed to operate throughout the range of entering fluid temperature 50 to 100°F in the cooling mode and 50 to 80°F in the heating mode. Units shall have an operating range of 50 to 110°F in the cooling mode and 25 to 80°F in the heating mode when equipped with the optional extended range package.
- B. Units shall be individually packaged with wooden skid covered with protective corner posts and plastic stretch wrapping for maximum protection.

1.02 QUALITY ASSURANCE

- A. Unit shall be certified (sizes 072-120) or rated in accordance with AHRI/ISO/ASHRAE (Air-Conditioning, Heating and Refrigeration Institute/International Organization for Standardization/American Society of Heating, Refrigerating, and Air-Conditioning Engineers) Standard 13256-1, latest edition.
- B. Units shall have insulation and adhesive which meet NFPA (National Fire Protection Association) 90A requirements for flame spread and smoke generation, and assembled units shall be UL (Underwriters Laboratories) listed, US and Canada, and meet UL-181 standards.
- C. Units shall undergo factory testing to verify operation of major components and safety devices prior to shipment.

Part 2 — Product

2.01 EQUIPMENT

A. Heat Pump Assembly:

Factory-tested and assembled single-piece water source heat pump units shall be factory wired, charged with Puron refrigerant (R-410A), contain refrigerant-to-water heat exchanger, refrigerant-to-air heat exchanger, 4-way reversing valve, fan motor assembly, compressor, metering device, and all internal controls and safety devices.

B. Unit Cabinet:

1. All water source heat pumps shall be fabricated from heavy-gage sheet metal steel. All interior surfaces shall be lined with 1/2-in thick, multi-density acoustic insulation. Insulation within the air-handling section shall not have any exposed edges. All insulation must meet NFPA 90A and be certified to meet the GREENGUARD Indoor Air Quality Standard for Low Emitting Products. One blower access panel and two

compressor compartment access panels shall be removable with supply and return air ductwork in place.

2. Cabinets shall have separate holes and knock-outs for entrance of line voltage and low voltage control wiring. Supply and return water connections shall be copper FPT fittings and shall be securely mounted flush to the cabinet allowing for connection to a flexible hose without the use of a back-up wrench. Water connections which protrude through the cabinet shall not be allowed.
3. Units shall have the airflow arrangement as shown on the plans. If units with these arrangements are not used, the contractor supplying the water source heat pumps is responsible for any extra costs incurred by other trades and must submit detailed mechanical drawings showing ductwork requirements and changes or relocation of any other mechanical or electrical system. If other arrangements make servicing difficult the contractor must provide access panels and clear routes to ease service. The architect must approve all changes 10 days prior to bid.
4. All units shall have a factory-installed two-sided filter rack capable of accepting 1-in. filters. Units shall have a 1 in. thick throwaway type fiberglass filter as standard. The filter rack shall incorporate a 1 in. duct flange.
5. All units shall have stainless steel drain pans to comply with this project's IAQ (indoor air quality) requirements. Painted steel or plastic materials shall not be permitted.

C. Fan and Motor Assembly:

1. The fan(s) shall be belt driven DWDI forward curved type with dynamically balanced wheel(s). The fan motor(s) shall be 1725 or 3450 rpm 56 frame sealed ball bearing type.

The motor(s) shall be permanently lubricated and have thermal overload protection.

2. The fan and motor assembly must be capable of overcoming the external static pressures as shown on the schedule. External static pressure rating of the unit shall be based on a wet coil. Ratings based on a dry coil shall not be acceptable.

D. Heat Exchangers:

1. Finned tube refrigerant to air heat exchanger. Refrigerant-to-air heat exchangers shall utilize enhanced aluminum fins and rifled copper tube construction rated to withstand 600 psig refrigerant working pressure. All air coils shall have non-ferrous aluminum end plates.
2. Coaxial (tube in tube) refrigerant-to-water heat exchanger:

Refrigerant-to-water heat exchangers shall be of copper inner water tube and steel outer refrigerant tube design rated to withstand 600 psig

working refrigerant pressure and 400 psig working water pressure. Shell and tube style refrigerant to water heat exchangers shall be treated as pressure vessels and shall require refrigerant pressure relief valves piped to the exterior of the building. The contractor supplying the water source heat pumps with shell and tube heat exchangers shall be responsible for any additional insulation costs. Brazed plate water-to-refrigerant heat exchangers shall require additional centrifugal separators added to the supply water piping at each unit. Each separator shall have an automated clean out valve piped to a waste line. The contractor supplying water source heat pumps with brazed plate heat exchangers shall be responsible for any additional cost.

3. Option for cupronickel water coil:

The refrigerant to water heat exchanger shall be cupronickel inner water tube.

E. Refrigerant Components:

1. Units shall use R-410A refrigerant. Units that use R-22 refrigerant shall not be allowed. All units shall have a factory sealed and fully charged refrigerant circuit with the following components.
2. Thermostatic expansion valve shall be provided for refrigerant metering.
3. Hermetic Compressor: Hermetic scroll compressors shall be specifically designed for R-410A refrigerant and shall be internally sprung (if reciprocating), externally isolated and with thermal overload protection. Unit compressors shall have rubber isolators to prevent transmission of vibration to the structure.
4. Reversing Valve: Reversing valves shall be four-way solenoid activated refrigerant valves which shall fail to the heating operation should the solenoid fail to function. Reversing valves which fail to the cooling operation shall not be allowed.

F. Controls and Safeties:

1. Safety devices on all units shall include low-pressure sensor or loss-of-charge switch, high-pressure switch, low water temperature sensor, and condensate overflow switch.
2. The standard unit control module shall provide control of major unit components and shall be compatible with heat pump thermostats or DDC controls. The standard control module shall have the following features:
 - a. Anti-short cycle time delay on compressor operation; time delay shall be 5 minutes minimum
 - b. Random start on power-up
 - c. Low voltage protection
 - d. High voltage protection

- e. Condensate overflow shutdown
 - f. Condensate overflow protection: A condensate sensor shall activate the lockout circuit upon sensing a high level of condensate in the drain pan and immediately put the unit into a hard lockout.
 - g. Unit shutdown on low or high refrigerant pressures.
 - h. Unit shutdown on low water temperature with adjustable limit for standard and extended range applications.
 - i. Option to reset unit at thermostat or disconnect.
 - j. Automatic intelligent reset. Unit shall automatically reset after a safety shutdown and restart the unit after the anti-short cycle timer and random start timer expire. Should a fault reoccur within 60 minutes after reset, then a permanent lockout will occur. Reset attempts shall be selectable for either 2 or 4 tries. Condensate overflow shall put the unit into a hard lockout on the first fault.
 - k. Ability to defeat time delays for servicing.
 - l. Light-emitting diode (LED) to indicate high pressure, low pressure, improper voltage, water coil freeze protection, condensate overflow, and control status.
 - m. Selectable 24-v or pilot duty dry contact alarm output.
 - n. Freeze Protection. The freeze protection sensor shall be mounted close to the water coil to monitor refrigerant temperature between water coil and the thermal expansion valve or capillary tube. If the refrigerant temperature between the expansion device and water coil drops below or remains at 30°F for 30 seconds, the controller shall shut down the compressor and enter into a soft lockout condition. This trip point can be changed to 15°F by cutting the R17 and R77 resistors located above the DIP switch SW1 for applications that employ antifreeze. The freezestat may not provide protection in the case of loss of flow in the heating mode. A flow switch or pressure differential switch is recommended to prevent unit operation in case of loss of flow.
 - o. Low pressure switch 120-second bypass timer.
 - p. Alarm output selectable for constant output for general alarm notification, or pulse output for communication of the specific fault alarm.
3. The optional Deluxe D control package shall have all the features of the Complete C control, with the following additional features:
 - a. Boilerless control. Shall activate an electric heater and disable compressor should water

- temperature drop below set point. Includes a relay and splitting the power supply to the unit into a blower motor and control power supply and a compressor power supply. The relay (when energized) deactivates the compressor control circuit.
- b. Auxiliary pump/valve relay to enable a pump/valve operation when calling for compressor operation.
 - c. Energy Management switch for remote enabling of the WSHP (water source heat pump).
 - d. Phase monitor to protect the compressor from operating in reverse rotation on three phase units.
4. WSHP Open Multiple Protocol Control:
- a. Units shall have all the features above (Complete C Board) and the state of the art WSHP Open multiple protocol interface board. All point objects will have the ability to be viewed in the Equipment Touch™, System Touch™ or field assistant user interface. The following points must be available at a central or remote computer location:
 - 1) Space temperature
 - 2) Leaving water temperature
 - 3) Discharge air temperature
 - 4) Command of space temperature set point
 - 5) Cooling status
 - 6) Heating status
 - 7) Low temperature sensor alarm
 - 8) High pressure switch alarm
 - 9) Fan on/off position of space thermostat
 - 10) Unoccupied/occupied command
 - 11) Cooling demand
 - 12) Heating demand
 - 13) Fan “ON/AUTO” command
 - 14) Fault prevention with auto reset
 - 15) Itemized fault code viewed with Equipment Touch interface
 - b. Additional WSHP Open multiple protocol control features shall include:
 - 1) Three-speed fan control. Controller shall automatically, based upon space temperature input, operate the fan at the lowest of 3 selectable speeds to achieve space temperature set point. A VFD (variable frequency drive) is required to operate 3-speed fan control.
 - 2) Two-position OA (outdoor air) damper
 - 3) Modulating OA damper with DCV (demand controlled ventilation)
 - 4) Hot gas reheat solenoid valve
 - 5) Two-position water economizer control
 - 6) Modulating water economizer control
 - 7) Single-stage electric auxiliary heat
 - 8) Power fail restart delay
 - 9) Two-stage compression control
5. Multiple-protocol WSHP Open controller remote ZS sensors for DDC control options. Only Carrier ZS sensors can be used with the WSHP Open controller. Sensors are available as follows, and all sensors below offer monitoring of space temperature only, or space temperature and CO₂, or space temperature and humidity, or space temperature and CO₂ and humidity.
- a. ZS Standard sensor with a communication port.
 - b. ZS Plus sensor with communication port, occupancy status indicator, local occupancy override and set point adjustment.
 - c. ZS Pro sensor with communication port, occupancy status indicator, local occupancy override, set point adjustment, LCD display, alarm indicator and fan speed control.
 - d. ZS Pro-F sensor with communication port, occupancy status indicator, local occupancy override, set point adjustment, LCD display, alarm indicator, fan speed control, cooling/heating/fan only mode control and F to C conversion.
- G. Electrical:
1. A control box shall be located within the unit and shall contain a transformer, controls for the compressor, reversing valve and fan motor operation and shall have a terminal block for low voltage field wiring connections. The transformer shall be rated for a minimum 75 VA.
 2. Units shall be nameplated for use with time-delay fuses or HACR (heating, air-conditioning, and refrigeration) circuit breakers.
 3. Unit controls shall be 24-volt and provide heating or cooling as required by the remote thermostat.
 4. Units shall have a short circuit current rating (SCCR) of no less than 5 kA.
- H. Factory-Installed Options:
1. Closed Cell Foam:

Closed cell foam (CCF) shall be installed on interior surfaces of water source heat pump and shall meet the density and compression requirements of ASTM D-1056, the water absorption requirements of ASTM D-1667 and the tensile and elongation requirements of ASTM D-412. Closed cell foam shall meet the flammability requirements of FMVSS302 and UL 94.
 2. Sound Attenuation Package (Mute Package):

- Shall consist of a compressor blanket installed in the unit for additional attenuation.
3. **Extended Range:**

Extended range units shall provide an insulated water circuit for the coaxial coil and refrigerant circuit to prevent condensation, and therefore potential dripping problems, in applications where the entering water temperature is beyond the normal operating range.
 4. **Hot Gas Reheat:**

Units as noted on the schedule shall be equipped with optional hot gas reheat (HGRH). On/Off HGRH shall be controlled by a humidistat connected to the unit H terminal and shall start the unit in reheat mode should the humidity be above set point once the thermostat control is satisfied. Cooling or heating requirements shall take precedent over HGRH.
 5. **Hot Gas Bypass:**

For units as noted on the schedule, supply each unit with a UL listed and MEA listed modulating hot gas bypass valve with factory-supplied and installed controls to prevent air coils from frost development by taking hot gas and bypassing the water coil and expansion device and reintroducing the hot gas into the refrigerant line prior to the air coil. The hot gas bypass valve shall maintain the minimum refrigerant suction pressure to allow for a light load cooling mode or a low entering air temperature cooling mode.
 6. **Waterside Economizer:**

Waterside economizer shall be completely installed at the factory, with condensate drain pan(s), motorized 3-way valve, aquastat, and all internal electric controls. Waterside economizer shall be rated at 400 psig and UL listed for application with the heat pump.
 7. **Evaporator Coil Protection:**

Evaporator coil protection shall be factory-installed with tin electro-plated copper tubing and high-tech polymer coated aluminum fins to protect the air coil from all forms of corrosive elements in the airstream.
 8. **1-Speed VFD:**

Unit shall include a factory installed (50VQP) or field installed (50HQP) supply fan VFD with factory installed inverter duty motor. Two speed motors without VFDs or ECM motors are not acceptable.
 9. **Staged Air Volume (SAV) – 2-Speed:**

Unit shall include a factory-installed (50VQP) or field-installed (50HQP) supply fan VFD with factory-installed inverter duty motor. Unit and VFD shall be configured for stage air volume control in which the supply fan airflow can be varied based on load. Two speed motors without VFDs or ECM motors are not acceptable.
 10. **2 In. Filter Rack:**

Unit shall include a factory installed 2 in., four sided filter rack with factory supplied 1 in. throwaway filters. Filter rack design shall not require the use of tools for filter changes. Hinges, thumb-screws, or screws for filter access are not acceptable.
- I. **Accessories:**
 1. **Hose Kits and Valves:**

All units shall be connected to main water supply and return headers with hoses. The hoses shall be 2 or 3 feet long, braided stainless steel rated to 400 psig at 265°F. Hoses may contain optional ball valves with P/T (pressure/temperature) ports, Y strainers with blow down valves and/or autoflow regulators as specified in the schedule.
 2. **Ball Valves (Brass Body):**

Valves shall be available for shutoff and balancing water flow. Available with memory, memory stop, and pressure temperature ports.
 3. **Y Strainers (Bronze Body):**

Strainers are “Y” type configuration with a brass cap. Maximum operating pressure rating of strainers is 450 psig. Strainer screen shall be made of stainless steel.
 4. **Electric Duct Heaters:**
 - a. Duct heater shall be slip-in or flanged type and shall be UL approved for zero clearance to combustible surfaces. The heater shall bear a UL/CSA (Canadian Standards Association) label. Control panel and element housing shall be constructed of heavy gage galvanized steel. All heating elements shall be made of nickel/chromium resistance wire with ends terminated by means of staking and heliarc welding to machine screws. Heating element support structure shall consist of galvanized steel wire formed and constructed to support ceramic bushings through which the heating element passes. Control cabinet shall be constructed of heavy gage galvanized steel with multiple knockouts for field wiring. Control cabinet shall have a solid cover also of heavy gage galvanized steel and held in place with hinges and tool-release latches.
 - b. Duct heater shall be supplied with primary over temperature protection by built in disc type automatic reset thermal cutouts and secondary over temperature protection by built in disc type manually resettable thermal cutouts. These devices must function independently of one another and are not acceptable if series connected in the control circuit wiring. A disconnecting magnetic control circuit is required. All duct heaters will require either a fan interlock circuit or an airflow switch.

- c. Over-current protection by means of factory-installed fusing within the control cabinet shall be provided for heaters rated at more than 48 amps. Heating elements shall be subdivided and fused accordingly.
- d. All wiring, component sizing, component spacing and protective devices within the control cabinet shall be factory installed and comply with NEC (National Electrical Code) and UL (Underwriters Laboratories) standardization. All heaters shall function properly with a 60 Hz power supply.
- e. A wiring diagram depicting layout and connections of electrical components within the control cabinet shall be affixed to the inside of the control cabinet cover.
- f. A rating plate label shall be affixed to the exterior of the control cabinet cover which states model number, serial number, volts, amps, phase, frequency, control volts, volt-amps and minimum airflow requirements.



