

# TECHNICAL MANUAL

## Chilled Water Fan Coil Units

**FWW, FWKE, FWC, FUD Series**

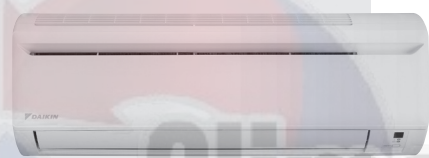

FWW-L



FWKE-E

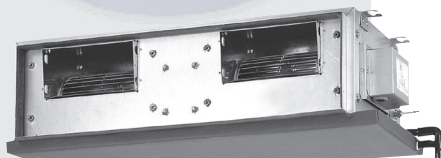

FWC-C

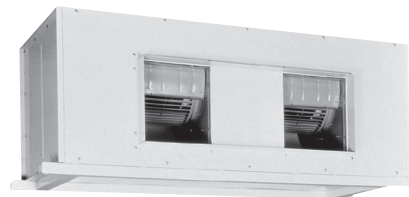

FUD-B

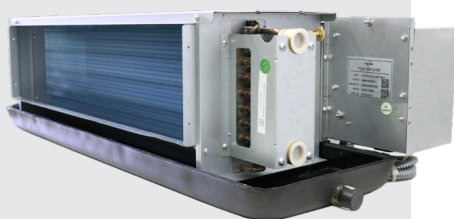

FWC-G EC

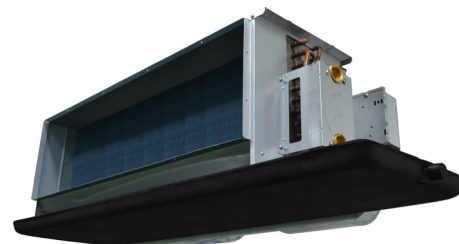

FWC-G



---

# Table of Contents

<b>Nomenclature</b> .....	<b>1</b>
Product Line-Up.....	1
<b>Application Information</b> .....	<b>6</b>
Operating Limits .....	6
Installation Guide.....	8
<b>Sound Data</b> .....	<b>21</b>
Sound Pressure Level .....	21
Sound Power Level .....	26
NC Curve.....	31
<b>Selection Process</b> .....	<b>52</b>
Fan Performance Curve .....	54
<b>Engineering &amp; Physical Data</b> .....	<b>88</b>
<b>Outlines &amp; Dimensions</b> .....	<b>102</b>
<b>Wiring Diagrams</b> .....	<b>116</b>
<b>Service &amp; Maintenance</b> .....	<b>124</b>
<b>Troubleshooting</b> .....	<b>125</b>



Climaproyectos

---



# Nomenclature

**FWW 02 L - K C E AB**

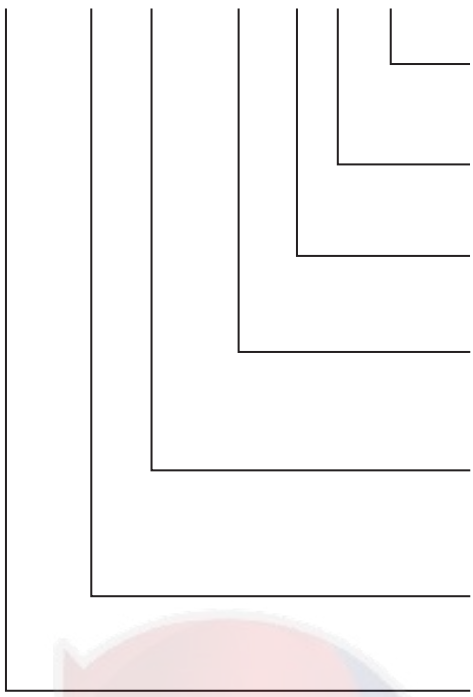

**Revision**

AA: Revision 1  
AB: Revision 2

**Specification**

E: Cooling Only  
H: Cooling and Heating

**Market**

C: Export with CE Mark  
E: Export without CE Mark

**Power Supply**

A: 220-240V/1Ph/50Hz  
F: 380-415V/3Ph/50Hz  
K: 208-230V/1Ph/60Hz

**Product Series**

L: L series (for FWW)  
D: D series (for FWE)  
E: E series (for FWE)

**Size**

02: 2 kW\*  
03: 3 kW\*

**Fan Coil Unit Type**

FWW: Wall Mounted  
FWE: Ceiling Convertible / Ceiling Exposed

**FWK 06 E - K C C AA**

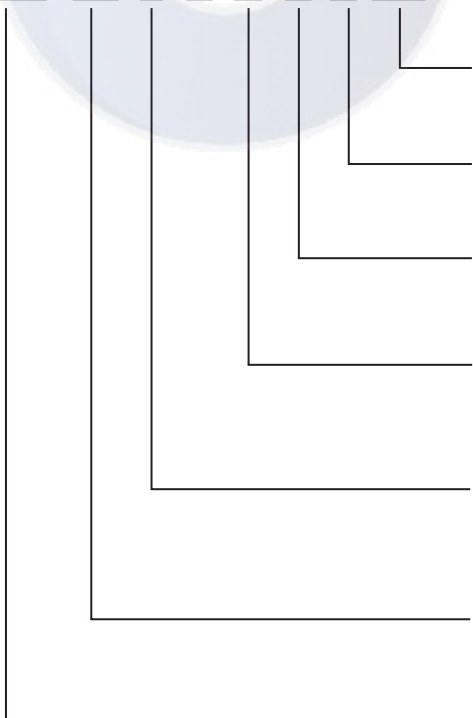

**Revision**

AA: Revision 1  
AB: Revision 2

**Specification**

C: AC Motor Cooling and Heating  
D: DC Motor Cooling and Heating

**Market**

C: Export with CE Mark  
E: Export without CE Mark

**Power Supply**

A: 220-240V/1Ph/50Hz  
F: 380-415V/3Ph/50Hz  
K: 208-230V/1Ph/60Hz

**Product Series**

C: C series (for FWF)  
E: E series (for FWK/FWKE)  
EH: EH series (for 4 Pipes FWK/FWKE)

**Size**

06: 6 kW\*  
08: 8 kW\*

**Fan Coil Unit Type**

FWF: Ceiling Cassette (600x600)  
FWK: Ceiling Cassette (900x900)  
FWKE: Ceiling Cassette (900x900) DC Motor

Remark:

\* : Capacity value under Nomenclature is an indication.

Please refer to Engineering and Physical Data for exact capacity value

**FWC 03 C - K C A A A**

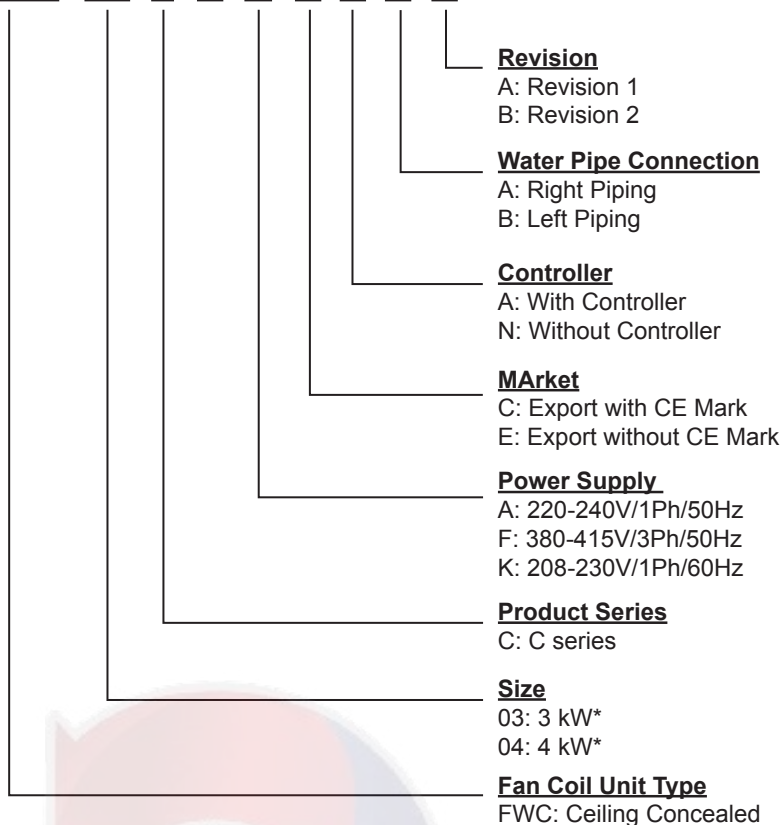

**FUD 20 B - K C N P A**

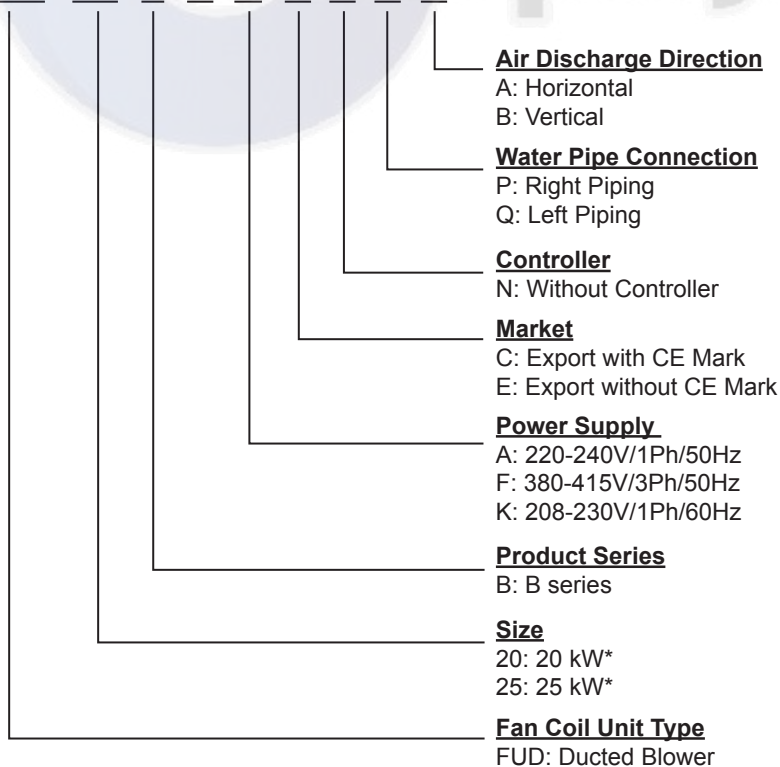

Remark:

\* : Capacity value under Nomenclature is an indication.

Please refer to Engineering and Physical Data for exact capacity value

**FWC 10 G - K E 5 C X X A X D A**

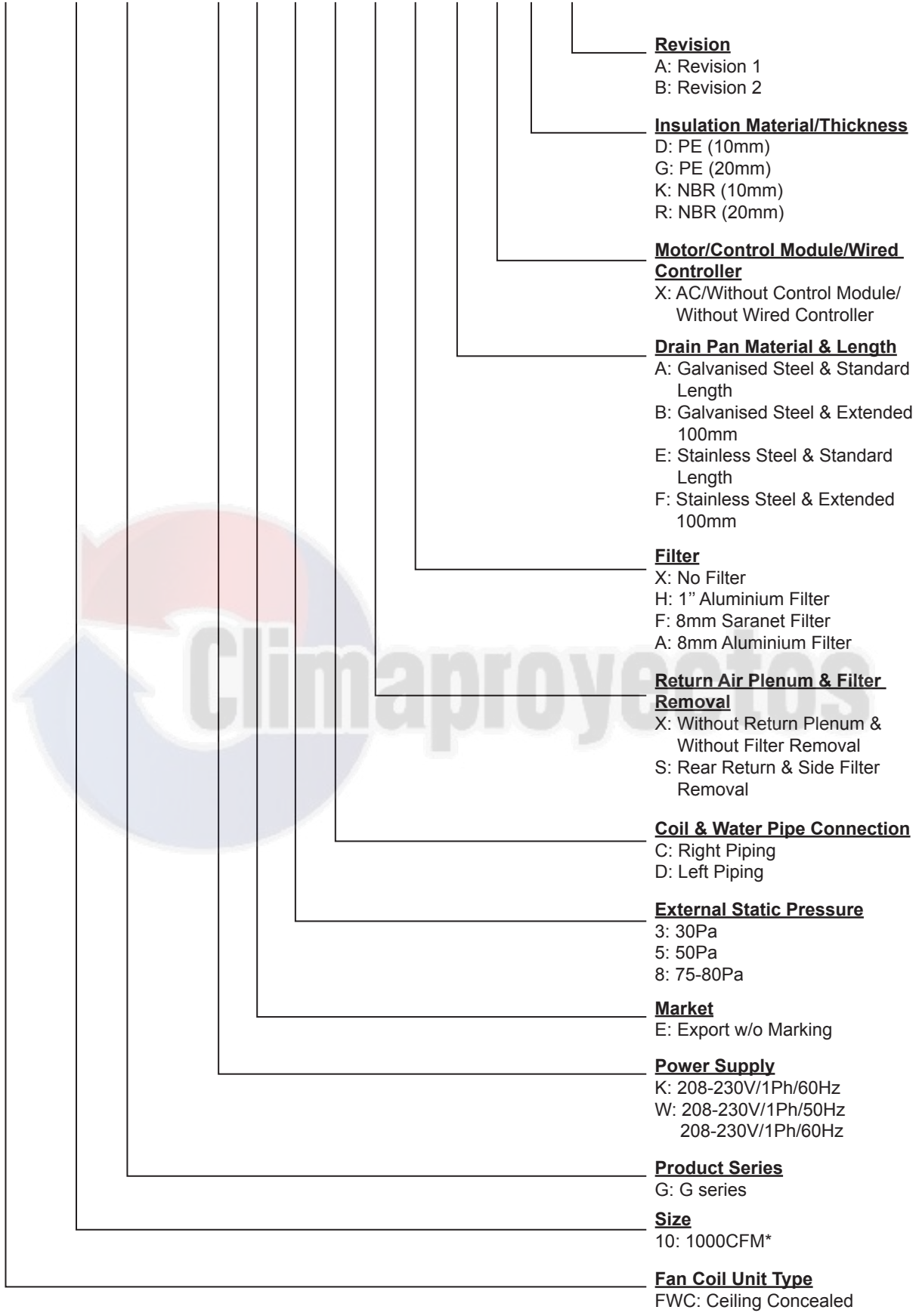

Remark:

\* : Air Flow Rate value under Nomenclature is an indication.

Please refer to Engineering and Physical Data for exact capacity value

Note:

Please consult factory for customised enquiry.

Product Line-Up

Chilled Water Fan Coil Units

Model	Classification																	
	PCB				Handset		Control			Connection		Air Discharge		Filter				
	50WJWXX*	UCW_W2.0*	W3*	W3DC*	Without Controller	BRC52A	BRC51A	Auto Air Swing	Turbo	Quiet	1/2" BSP Female Thread Adaptor	3/4" BSP Female Thread Adaptor	1 1/4" BSP Female Thread Adaptor	Horizontal Flow	Vertical Flow	Convertible	Saranet Filter	Viledon R29
FWW03L	X					X		X	X	X	X						X	
FWW04L	X					X		X	X	X	X						X	
FWW05L	X					X		X	X	X	X						X	
FWW06L	X					X		X	X	X	X						X	
FWKE05E(H)				X		X		X	X	X		X					X	
FWKE08E(H)				X		X		X	X	X		X					X	
FWKE11E(H)				X		X		X	X	X		X					X	



Model	Classification																					
	PCB					Handset		Control			Connection				Air Return			Air Discharge			Filter	
	50WJWXX*	UCW_W2.0*	W3*	W3DC*	Without Controller	BRC52A	BRC51A	Auto Air Swing	Turbo	Quiet	3/4" BSPT Female Thread Adaptor	3/4" BSP Female Thread Adaptor	1" BSPT Female Thread Adaptor	1 1/4" BSP Female Thread Adaptor	Horizontal Flow	Vertical Flow	Convertible	Rear Return	Bottom Return	Convertible	Saranet Filter	Viledon R29
FWC03C	X					X					X				X			X			X	
FWC04C	X					X					X				X			X			X	
FWC06C	X					X					X				X			X			X	
FWC07C	X					X					X				X			X			X	
FWC09C	X					X					X				X			X			X	
FWC12C	X					X					X				X			X			X	
FWC14C	X					X					X				X			X			X	
FWC16C	X					X					X				X			X			X	
FWC03G					X						X				X			X				
FWC04G					X						X				X			X				
FWC06G					X						X				X			X				
FWC08G					X						X				X			X				
FWC10G					X						X				X			X				
FWC12G					X						X				X			X				
FWC14G					X							X			X			X				
FWC16G					X							X			X			X				
FWC18G					X							X			X			X				
FWC20G					X							X			X			X				
FUD20B					X								X	X				X			X	
FUD25B					X								X	X				X			X	
FUD30B					X								X	X				X				X

\* PCB naming

\*\* Standard Model, optional items please refer to Nomenclature.

# Application Information

## Model: FWW

### Operating Limits:

Thermal carrier : Water

Water temperature : 4°C ~ 10°C (Cooling), 35°C ~ 50°C (Heating)

Maximum water pressure : 16 bar

Air temperature : (as below)

### Cooling Mode

Temperature	Ts °C/°F	Th °C/°F
Minimum indoor temperature	19.0 / 66.2	14.0 / 57.2
Maximum indoor temperature	32.0 / 89.6	23.0 / 73.4

### Heating Mode

Temperature	Ts °C/°F	Th °C/°F
Minimum indoor temperature	15.0 / 59.0	-
Maximum indoor temperature	27.0 / 80.6	-

Ts: Dry bulb temperature.

Th: Wet bulb temperature.

## Model: FWKE

### Operating Limits:

Thermal carrier : Water

Water temperature : 4°C ~ 10°C (Cooling), 35°C ~ 50°C (2 Pipes) (Heating), 35°C ~ 70°C (4 Pipes) (Heating)

Maximum water pressure : 16 bar

Air temperature : (as below)

### Cooling Mode

Temperature	Ts °C/°F	Th °C/°F
Minimum indoor temperature	16.0 / 60.8	11.0 / 51.8
Maximum indoor temperature	32.0 / 89.6	23.0 / 73.4

### Heating Mode

Temperature	Ts °C/°F	Th °C/°F
Minimum indoor temperature	16.0 / 60.8	-
Maximum indoor temperature	30.0 / 86.0	-

Ts: Dry bulb temperature.

Th: Wet bulb temperature.

## Model: FWC-C

### Operating Limits:

Thermal carrier : Water

Water temperature : 4 ~ 10°C (Cooling), 35°C ~ 50°C (Heating)

Maximum water pressure : 16 bar

Air temperature : (as below)

### Cooling Mode

Temperature	Ts °C/°F	Th °C/°F
Minimum indoor temperature	19.0 / 66.2	14.0 / 57.2
Maximum indoor temperature	32.0 / 89.6	23.0 / 73.4

### Heating Mode

Temperature	Ts °C/°F	Th °C/°F
Minimum indoor temperature	15.0 / 59.0	-
Maximum indoor temperature	27.0 / 80.6	-

Ts: Dry bulb temperature.

Th: Wet bulb temperature.

**Model: FWC-G (MSP) , FWC-G EC (LSP & MSP)**

**Operating Limits:**

Thermal carrier : Water

Water temperature : 4 ~ 10°C (Cooling)

Maximum water pressure : 16 bar

Air temperature : (as below)

**Cooling Mode**

Temperature	Ts °C/°F	Th °C/°F
Minimum indoor temperature	19.0 / 66.2	14.0 / 57.2
Maximum indoor temperature	32.0 / 89.6	23.0 / 73.4

**Model: FUD**

**Operating Limits:**

Thermal carrier : Water

Water temperature : 4 ~ 10°C (Cooling), 35°C ~ 70°C (Heating)

Maximum water pressure : 16 bar

Air temperature : (as below)

**Cooling Mode**

Temperature	Ts °C/°F	Th °C/°F
Minimum indoor temperature	19.0 / 66.2	14.0 / 57.2
Maximum indoor temperature	32.0 / 89.6	23.0 / 73.4

**Heating Mode**

Temperature	Ts °C/°F	Th °C/°F
Minimum indoor temperature	15.0 / 59.0	-
Maximum indoor temperature	27.0 / 80.6	-

Ts: Dry bulb temperature.

Th: Wet bulb temperature.

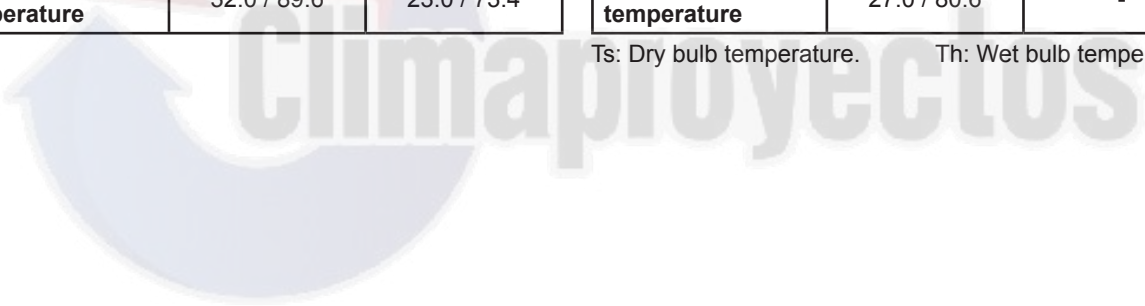

## Installation Guide

### System Configuration

The standard controller board comes with a VALVE jumper and a HEAT jumper. The system can be configured as the jumper selection listed below:

	HEAT Jumper	VALVE Jumper
Heatpump Mode & Valve Application	√	√
Heatpump Mode & Valveless Application	√	X
Cooling Mode & Valve Application	X	√
Cooling Mode & Valveless Application	X	X

√ Jumper Remained      X Jumper Removed



**Caution**

**Disconnect the power supply to the unit before attempting to connect the wiring**

### Valve, Heat and Fan Priority Setting

Model: FWW-L

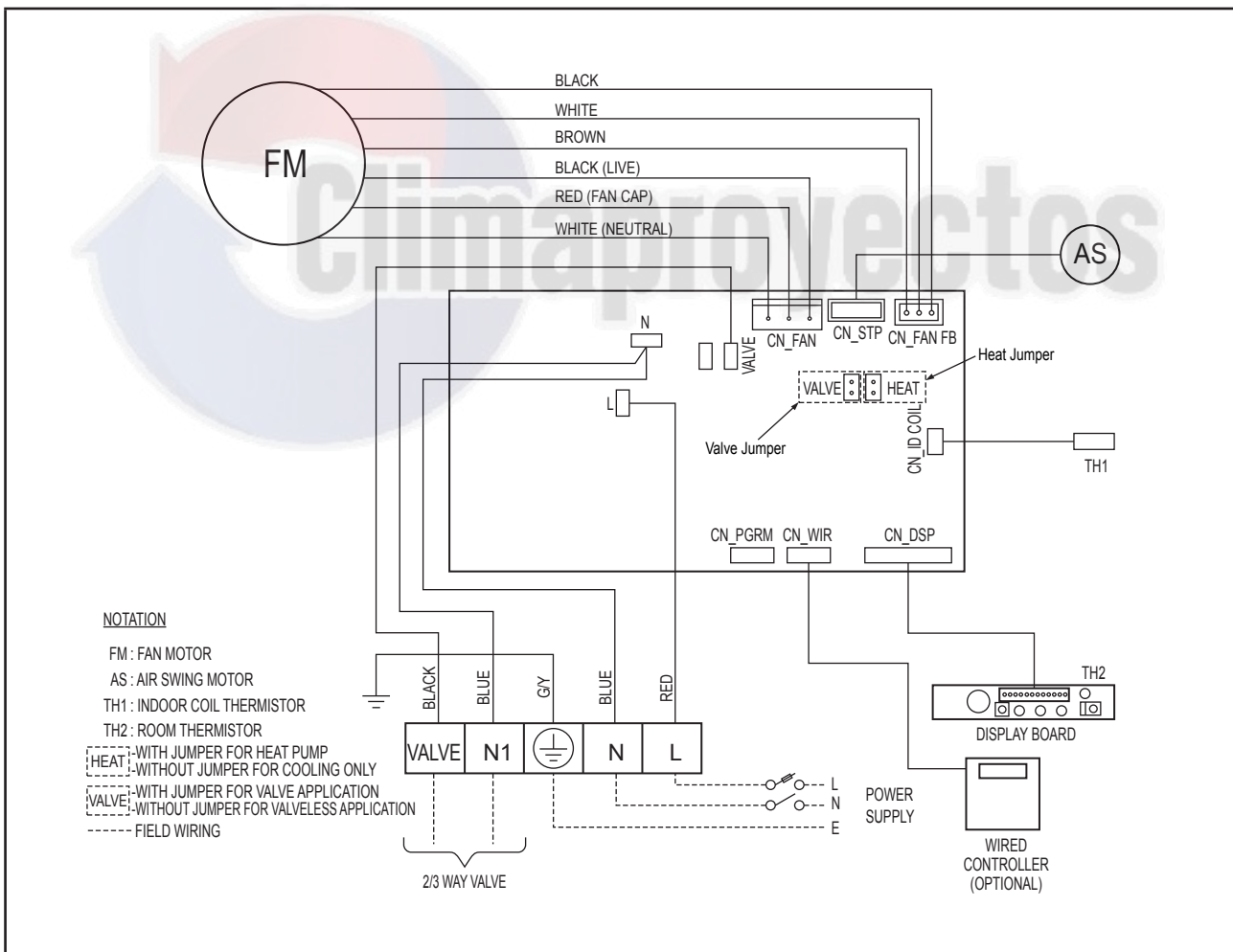

**Model: FWKE/FWC-C**

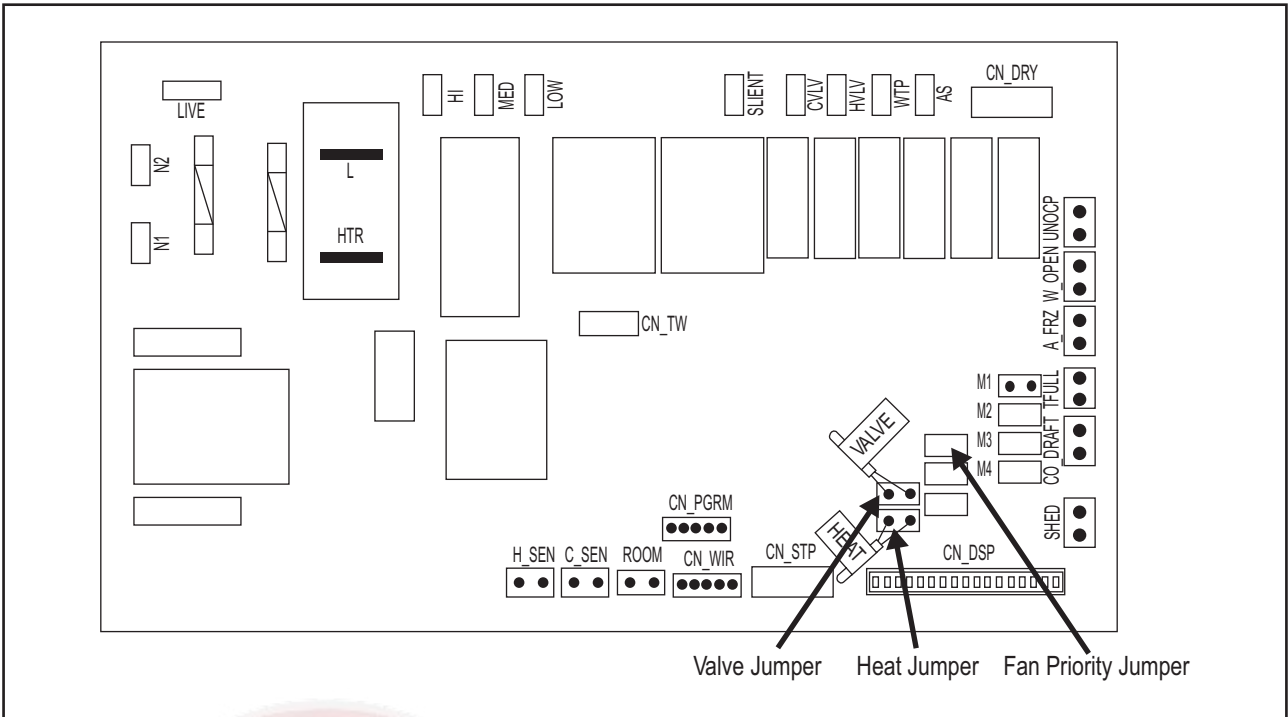

Jumper	With Jumper (Default)	Without Jumper
Fan Priority Jumper	User set speed or lower fan if auto mode is selected	Fan Stop when thermostat cat off
Heat Jumper	For Heat pump	For Cooling only
Valve Jumper	For valve control	For valveless control

4 pipes system controller board setting

**Model : FWKE-E(H)**

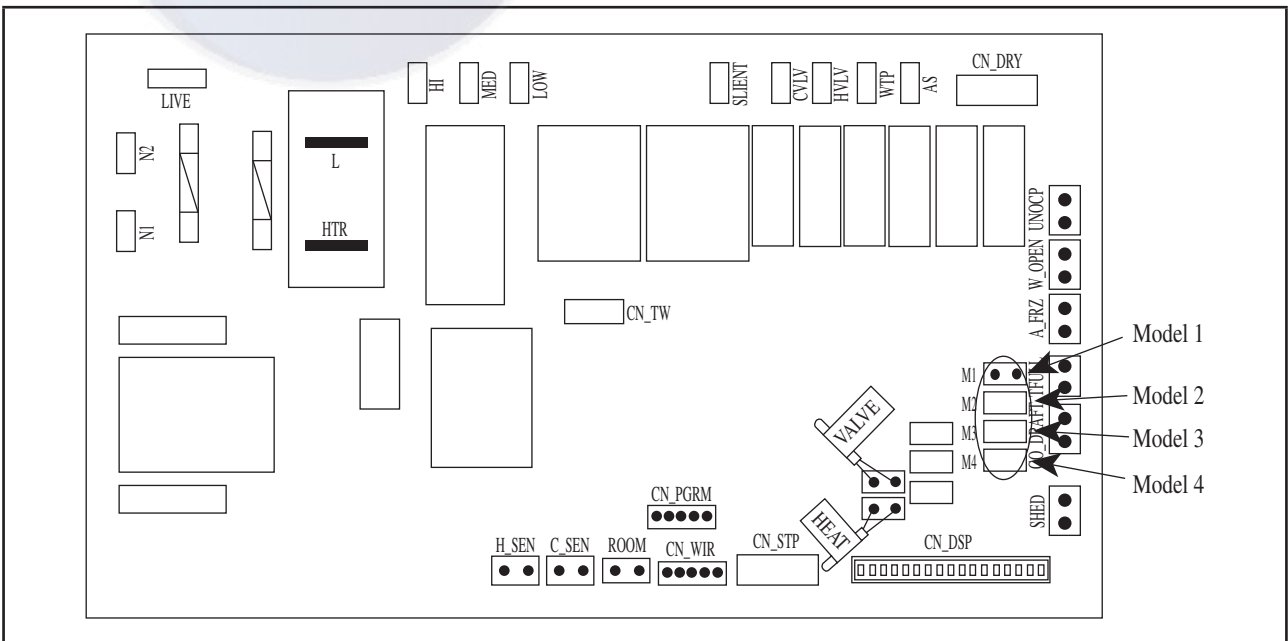

The standard controller board (W3) comes with a default setting for model selection. Please select the model accordingly by using jumper.

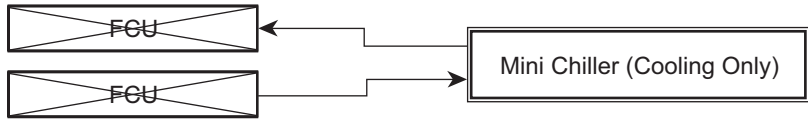
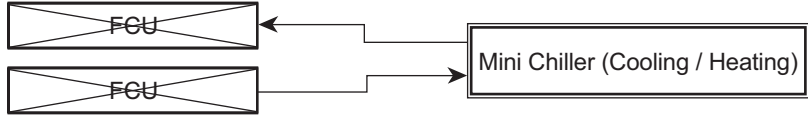
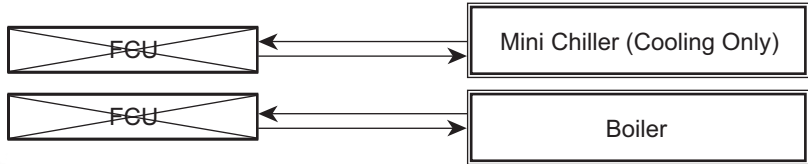
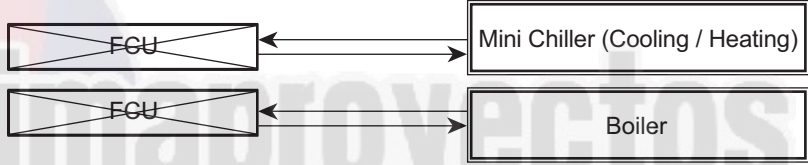
System	Model	Function
2 Pipe System	M1 - Model 1	Cooling or Heating 
	M2 - Model 2	Cooling or Heating with Auxiliary Heater 
4 Pipe System	M3 - Model 3	Cooling Only with Boiler 
	M4 - Model 4	Cooling or Heating with Boiler 

## NOTE :

- i) Auto Fan Mode is only applicable in Model 3 only. (Cooling only with Boiler)
- ii) Fan mode is not available in valveless control.
- iii) Wired handset has an indoor room sensor. Avoid locating the wired handset at isolated places where room temperature reading will be inaccurate.

## Indoor Installation

### Model: FWW-L

The indoor unit must be installed in such a way so as to prevent short circuit of the cool discharged air with the hot return air. Please follow the installation clearance shown in the figure. Do not place the indoor unit where there could be direct sunlight shining on it. Also, this location must be suitable for piping and drainage, and be away from doors or windows.

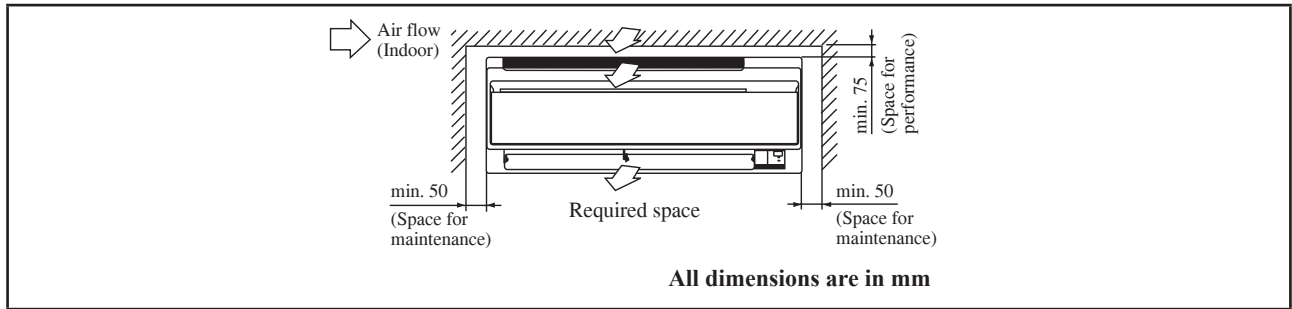

### Air Purging

To prevent pump damage, the fan coil unit should not be energized until the coil and all water lines have been purged of air.

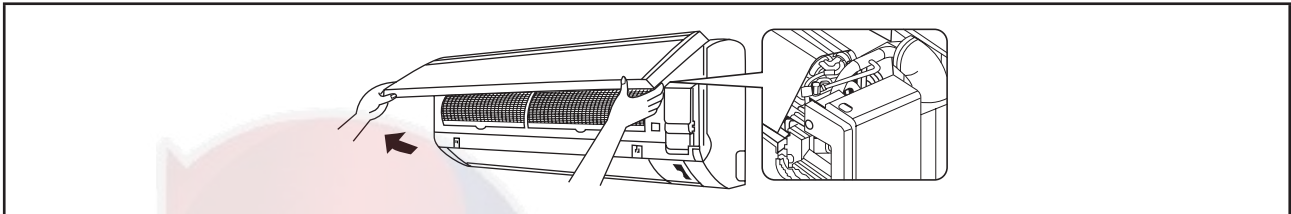

The Air Vent located inside the casing. Removed the casing and connect hose to the air vent while doing purging.



### Caution

Ensure there is no water droplets go into the control box during purging process.

The water piping can be routed to the unit in a number of ways (left or right from the back of the unit), by using the cut-out holes on the casing of the unit (see figure). Bend the pipes carefully to the required position in order to align it with the holes. For the side and bottom, hold the bottom of the piping and then position it to the required direction (see figure). The condensation drain hose can be taped to the pipes.

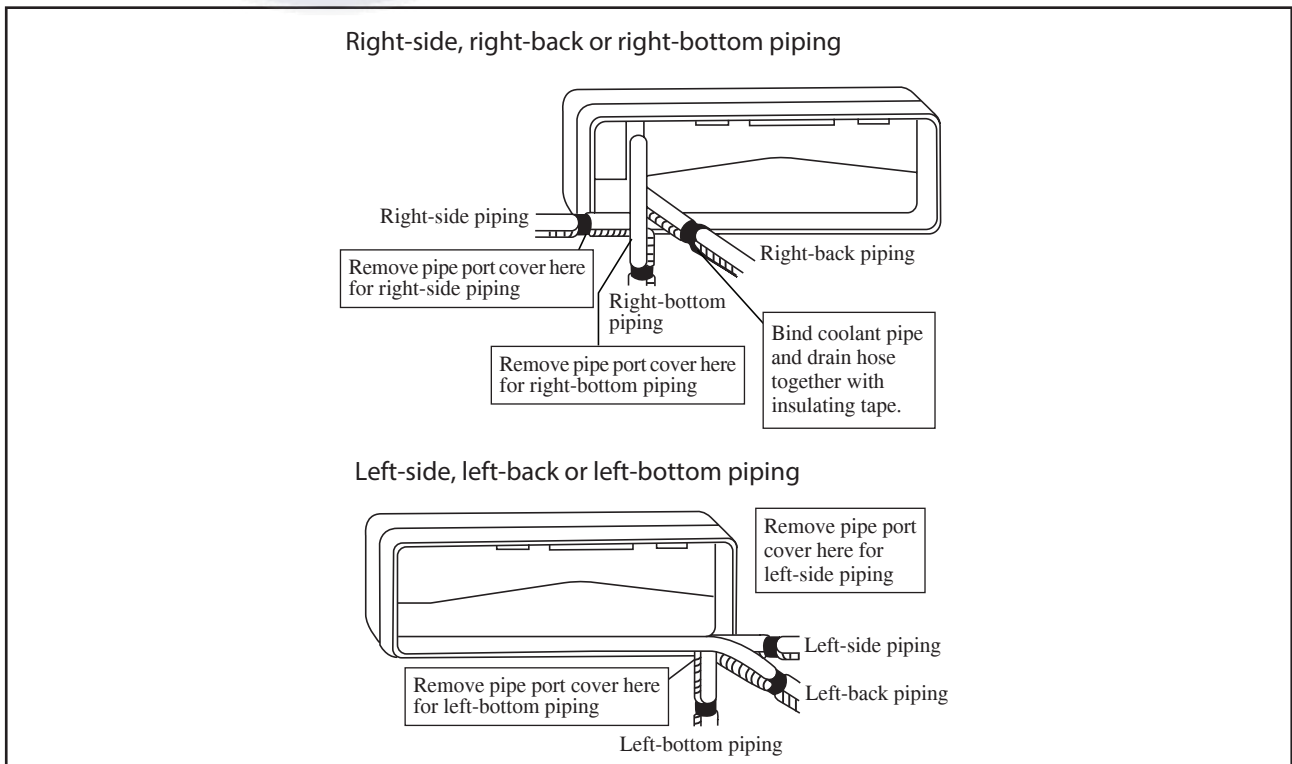

## Mounting Installation Plate

Ensure that the wall is strong enough to withstand the weight of the unit. Otherwise, it is necessary to reinforce the wall with plates, beams or pillars.

Use the level gauge for horizontal mounting, and fix it with 5 suitable screws for FWW02/03/04L and 7 suitable screws for FWW05/06L.

In case the rear piping draws out, drill a hole 65mm in diameter with a cone drill, slightly lower on the outside wall (see figure).

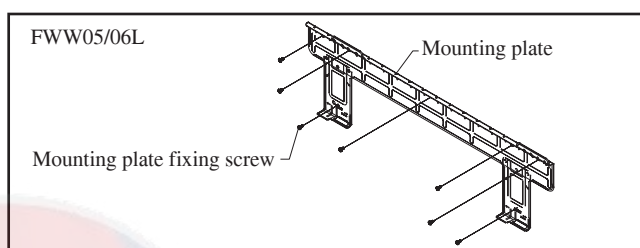
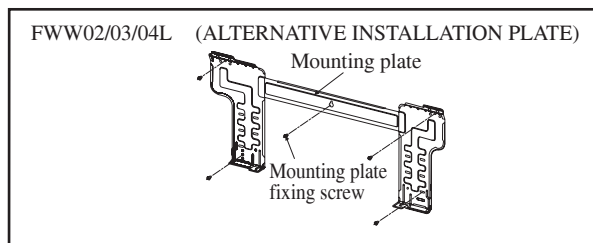
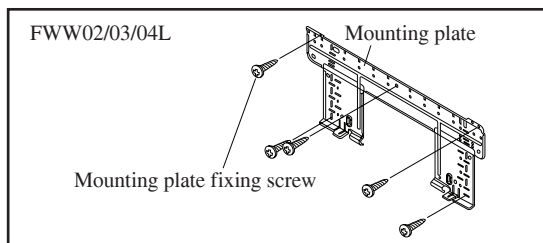

## Model: FWKE

### 1. Preliminary Site Survey

Be sure to read this manual before installing the air-conditioner indoor unit.

- Voltage supply fluctuation must not exceed +10% of rated voltage. Electricity supply lines must be independent of welding transformers which can cause high supply fluctuation.
- Ensure that the location is convenient for wiring, piping and drainage.
- Do not exert pressure on the resin parts when opening the unit or when moving it after opening.
- Do not move the unit from packaging while moving, until it reaches the installation site. Use safe material or protection plates when unpacking it or lifting it to avoid damage or scratches to the unit.

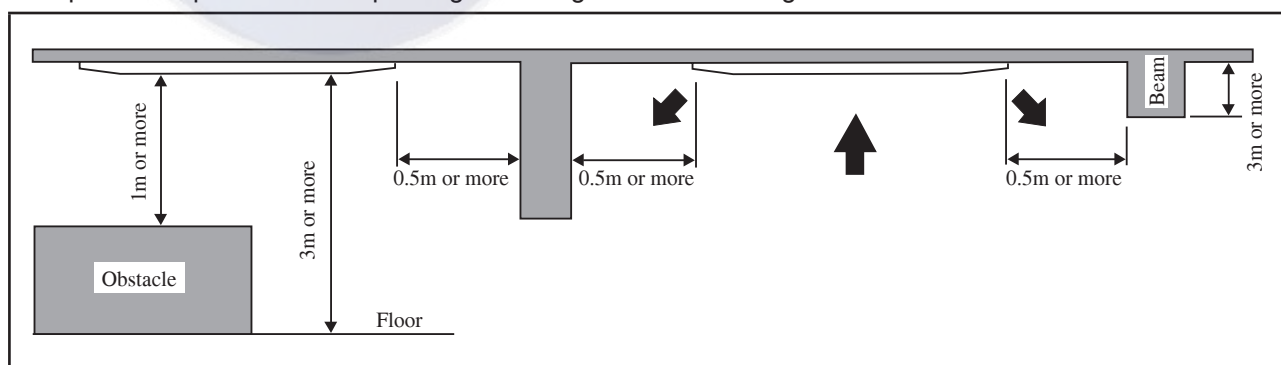

- Ensure a location where:
  - a) Drainage can be done easily.
  - b) Convenient for wiring and piping.
  - c) Which have enough space for installation and service work.
  - d) Where no risk of flammable gas leakage.
  - e) When free from any obstacles in path of cool air discharge and warm air return and must allow spreading of air throughout the room (near the center of the room).
  - f) Must be provided clearance for indoor unit from the wall and obstacles as shown in figure below.
  - g) The installation place must be strong enough to support a load 4 times the indoor unit weight to avoid amplifying noise and vibration.
  - h) The installation place (hanging ceiling surface) must be assuring levelness and the height in the ceiling is 350mm or more.
  - i) The indoor unit must be away from heat and steam sources (avoid installing it near an entrance).



**Unit Installation**

- Measure and mark the position for the hanging rod. Drill the hole for the angle nut on the ceiling and fix the hanging rod.
- The installation template is extended according to temperature and humidity. Check on dimensions in use.
- The dimensions of the installation template are the same as those of the ceiling opening dimensions.
- Before ceiling laminating work is completed, be sure to fit the installation template to the indoor unit.

**NOTE**  
Be sure to discuss the ceiling drilling work with the installers concerned.

**FWKE**

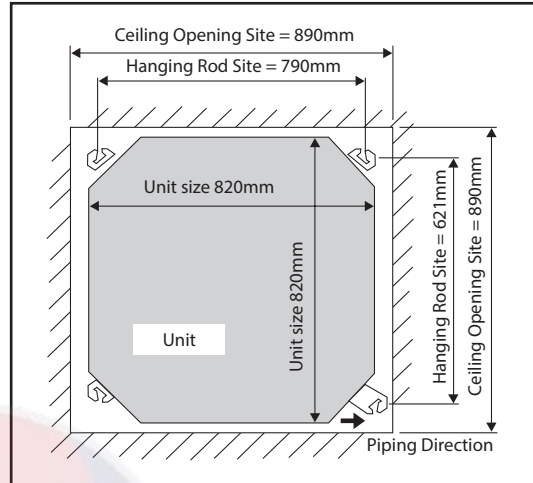

**Unit Hanging**

- Confirm the pitch of the hanging rod.
- Hold the unit and hang it on the hanging rod with the nut and washer.
- Adjust the unit height to 35.0mm between the indoor unit bottom surface and the ceiling surface.
- Confirm with a level gauge that the unit is installed horizontally and tighten the nut and bolt to prevent unit failing and vibration.
- Open the ceiling board along the outer edge of the paper installation template.

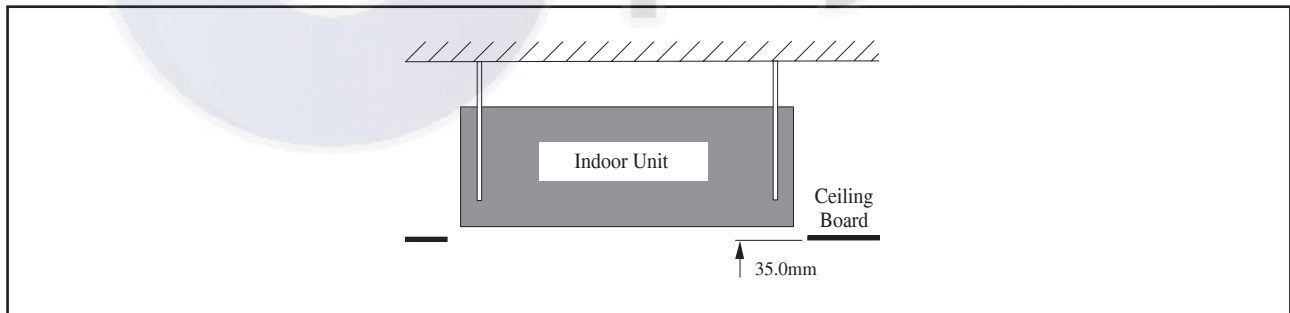

**Drain Piping Work**

- Drain pipe must be in downward gradient for smooth drainage.
- Avoid installing the drain pipe in up and down slope to prevent reversed water flow.
- During the drain pipe connection, be careful not to exert extra force on the drain connector at indoor unit.
- The outside diameter of the drain connection at the flexible drain hose is 20mm.
- Be sure to execute heat insulation (polyethylene foam with thickness more than 8.0mm) on the drain piping to avoid the condensed water dripping inside the room.

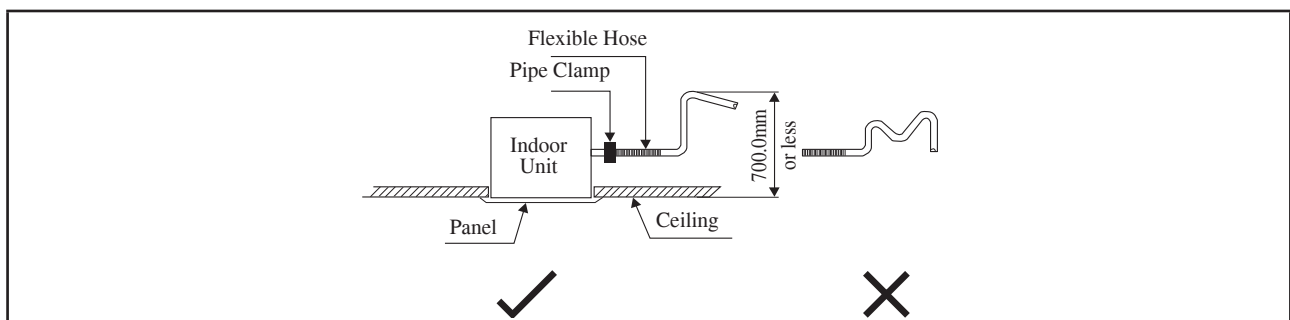

**Drain Test**

- Connect the main drain pipe to the flexible drain.
- Feed water from flexible drain hose to check the piping for leakage.
- When the test is completed, connect the flexible drain hose to the drain connector on the indoor unit.

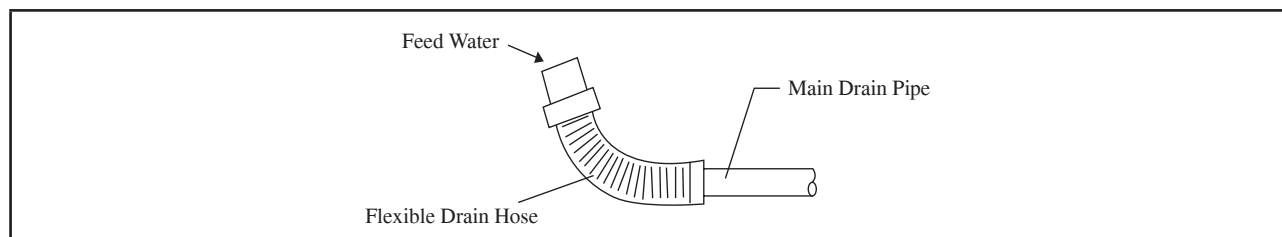
**NOTE**

This Indoor Unit uses a drain pump for condensed water drainage. Install the unit horizontally to prevent water leakage or condensation around the air outlet.

**Model: FWC-C**

The indoor unit must be installed such that there is no short circuit of the cool discharge. Respect the installation clearance. Do not put the indoor unit where there is direct sunlight on unit. The location is suitable for piping and drainage and it must have a large distance between a door and unit.

**Ceiling Concealed Mounting**

- Use the hanger supplied with the unit.
- Make sure that the ceiling is sufficiently strong to withstand the weight.

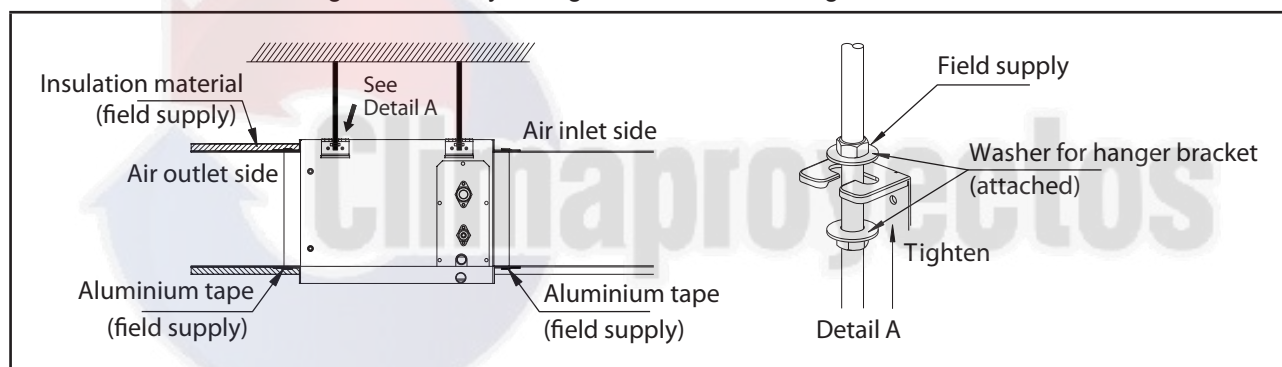

Provide clearance for servicing ease and optimal air flow as shown in the diagram.

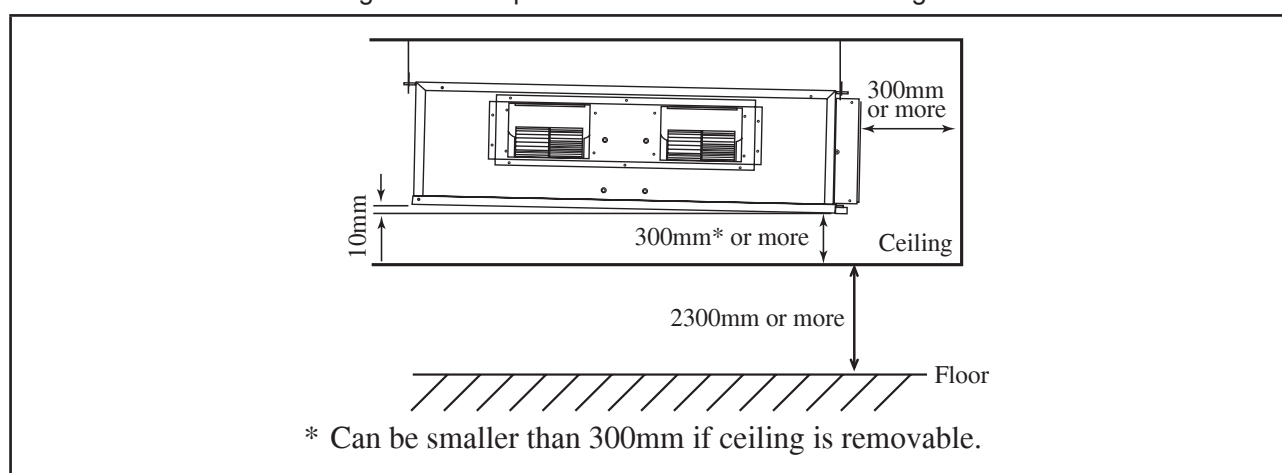

### Ceiling Concealed Drain Piping Work

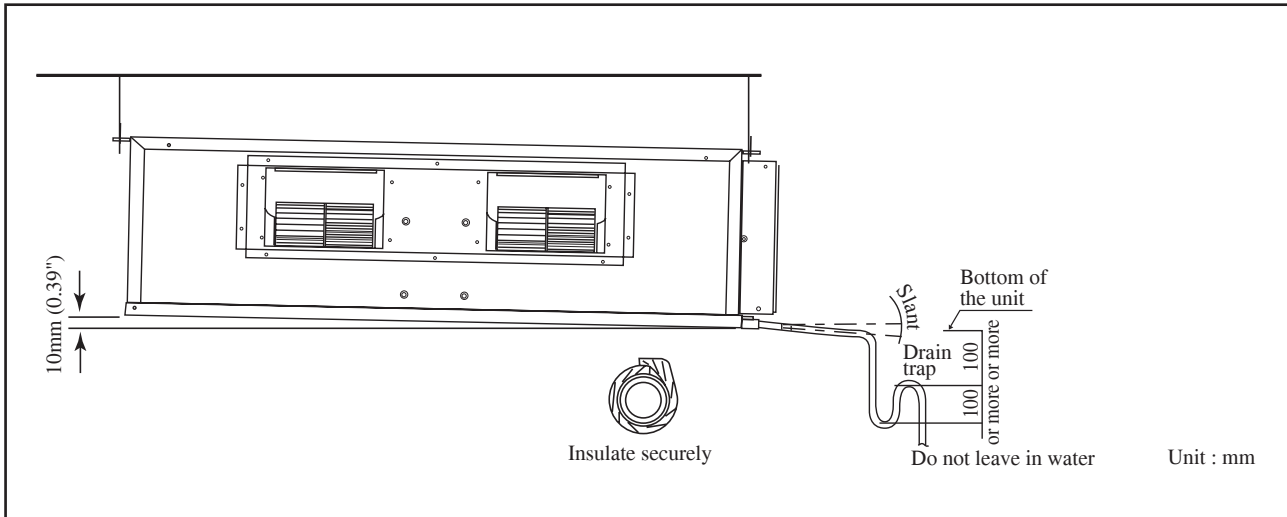

- The drain pipe must be installed as shown in the diagram (see diagram above) to avoid damage caused by leaks and condensation.
- For the best result, keep the piping as short as possible. Slant the piping at an angle to improve the flow.
- Ensure the drain pipe is securely insulated.
- It is necessary to provide a drain trap in the drain outlet to relieve pressure that exists within the unit compared to the outside atmospheric pressure when the unit is operating. The drain trap is to avoid possibility of splashes or an odor.
- Keep pipes as straight as possible for easy cleaning and to prevent the accumulation of dirt and debris.
- Conduct a water drainage test after the installation is completed. Make sure that the drainage flow is smooth.
- In humid environments, use an extra drain pan to cover the entire area of the indoor unit.



**Model: FWC-G (MSP)**

The indoor unit must be installed such that there is no short circuit of the cool discharge. Respect the installation clearance. Do not put the indoor unit where there is direct sunlight on unit. The location is suitable for piping and drainage and it must have a large distance between a door and unit.

**Ceiling Concealed Mounting**

- Use the hanger supplied with the unit.
- Make sure that the ceiling is sufficiently strong to withstand the weight.

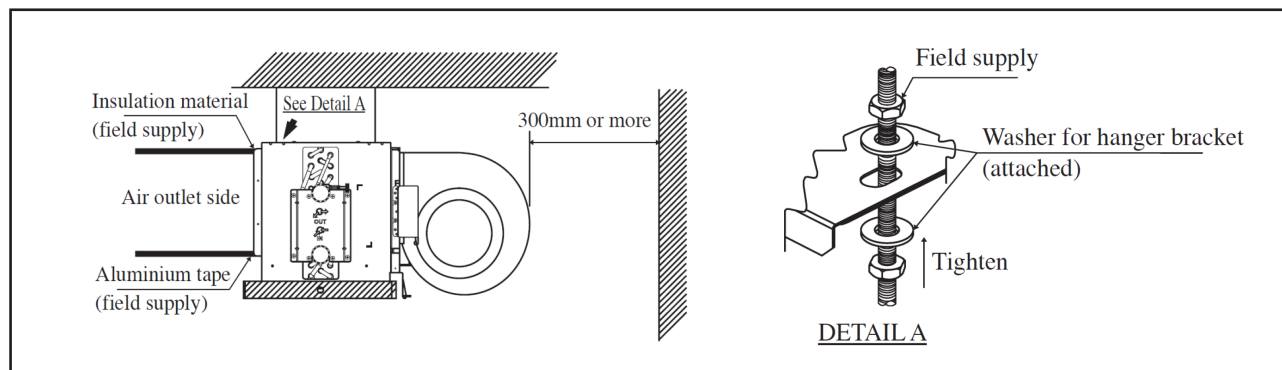

Provide clearance for servicing ease and optimal air flow as shown in the diagram.

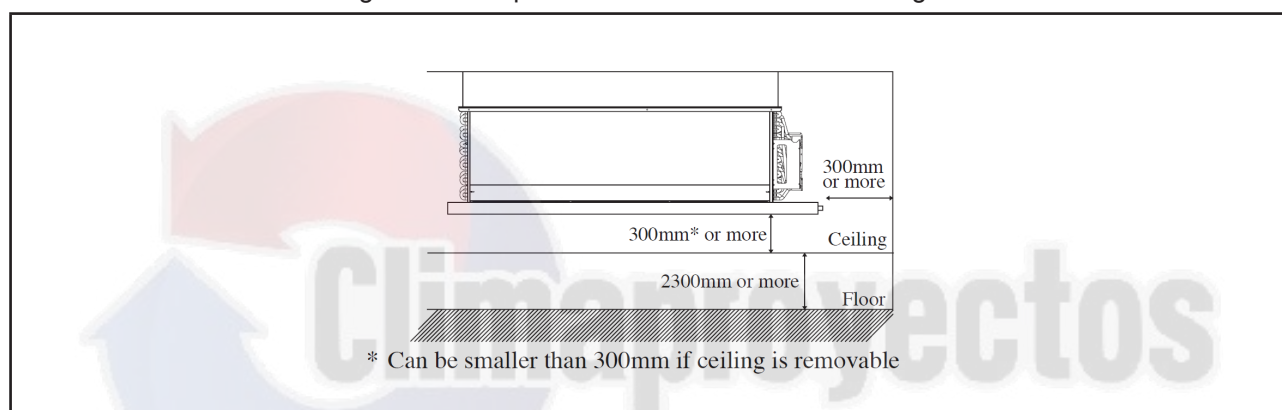
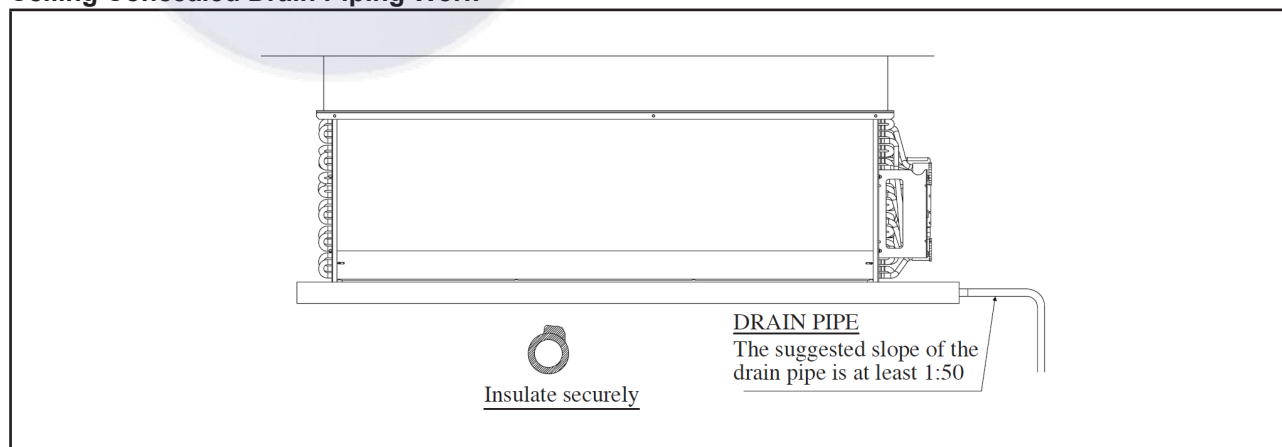
**Ceiling Concealed Drain Piping Work**

- The drain pipe must be installed as shown in the diagram (see diagram above) to avoid damage caused by leaks and condensation.
- For the best result, keep the piping as short as possible. Slant the piping at an angle to improve the flow.
- Ensure the drain pipe is securely insulated.
- It is necessary to provide a drain trap in the drain outlet to relieve pressure that exists within the unit compared to the outside atmospheric pressure when the unit is operating. The drain trap is to avoid possibility of splashes or an odor.
- Keep pipes as straight as possible for easy cleaning and to prevent the accumulation of dirt and debris.
- Conduct a water drainage test after the installation is completed. Make sure that the drainage flow is smooth.
- In humid environments, use an extra drain pan to cover the entire area of the indoor unit.

**Model: FWC-G EC (MSP,LSP)**

The indoor unit must be installed such that there is no short circuit of the cool discharge. Respect the installation clearance. Do not put the indoor unit where there is direct sunlight on unit. The location is suitable for piping and drainage and it must have a large distance between a door and unit.

**Ceiling Concealed Mounting**

- Use the hanger supplied with the unit.
- Make sure that the ceiling is sufficiently strong to withstand the weight.

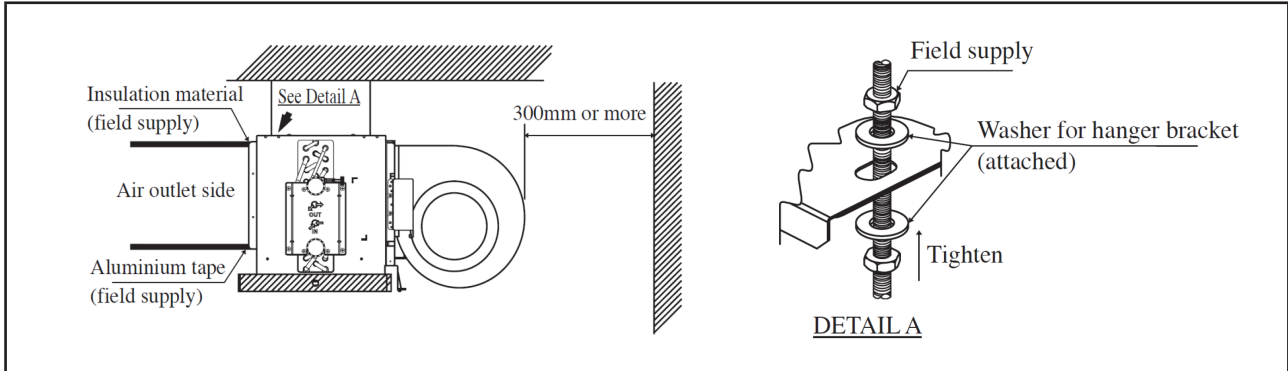

Provide clearance for servicing ease and optimal air flow as shown in the diagram.

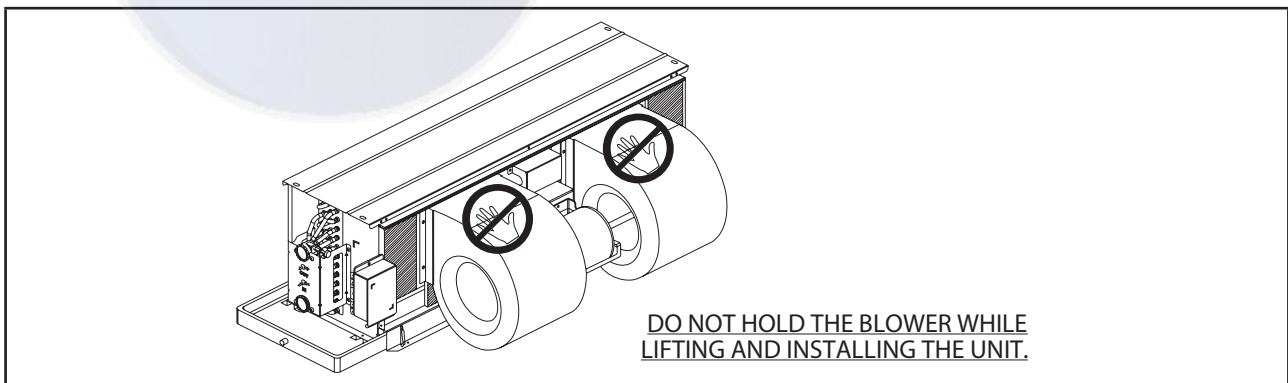
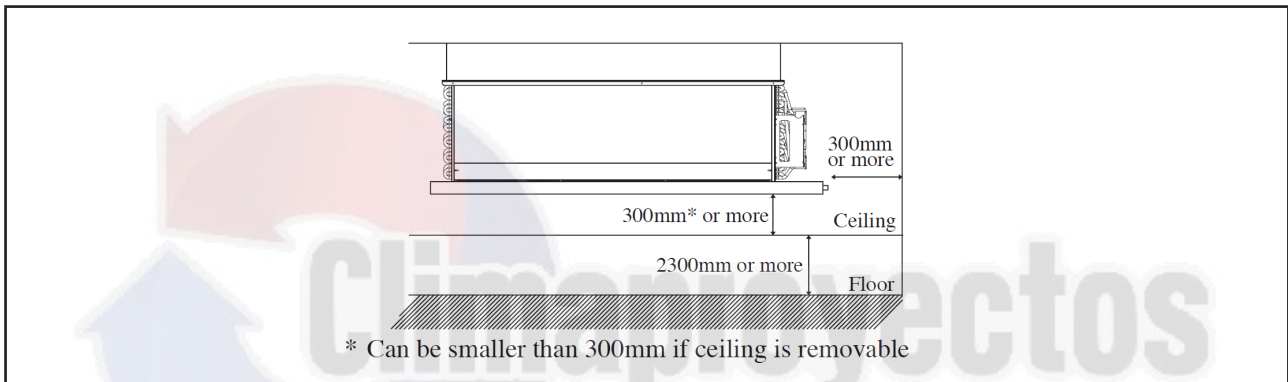

## Ceiling Concealed Drain Piping Work

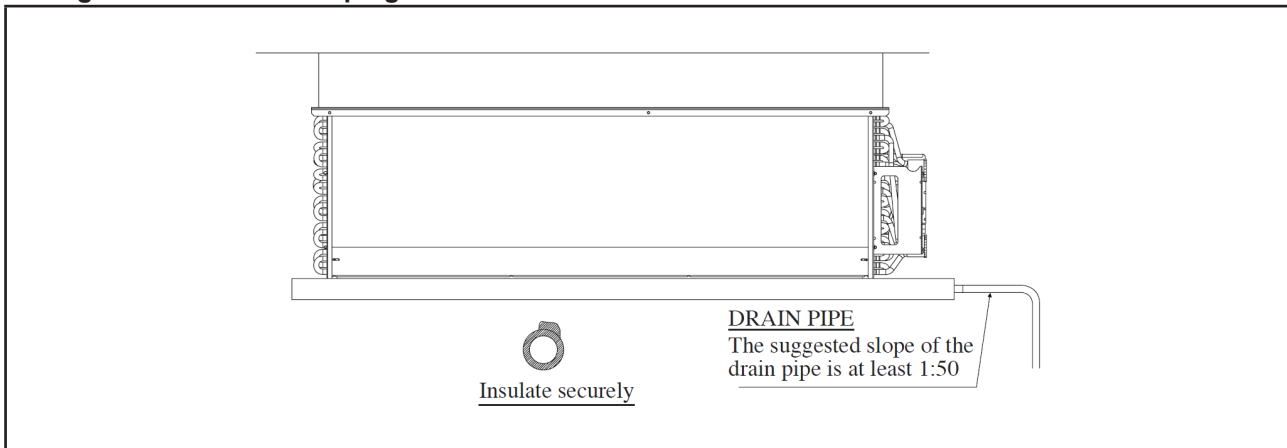

- The drain pipe must be installed as shown in the diagram (see diagram above) to avoid damage caused by leaks and condensation.
- For the best result, keep the piping as short as possible. Slant the piping at an angle to improve the flow.
- Ensure the drain pipe is securely insulated.
- It is necessary to provide a drain trap in the drain outlet to relieve pressure that exists within the unit compared to the outside atmospheric pressure when the unit is operating. The drain trap is to avoid possibility of splashes or an odor.
- Keep pipes as straight as possible for easy cleaning and to prevent the accumulation of dirt and debris.
- Conduct a water drainage test after the installation is completed. Make sure that the drainage flow is smooth.
- In humid environments, use an extra drain pan to cover the entire area of the indoor unit.



### Important

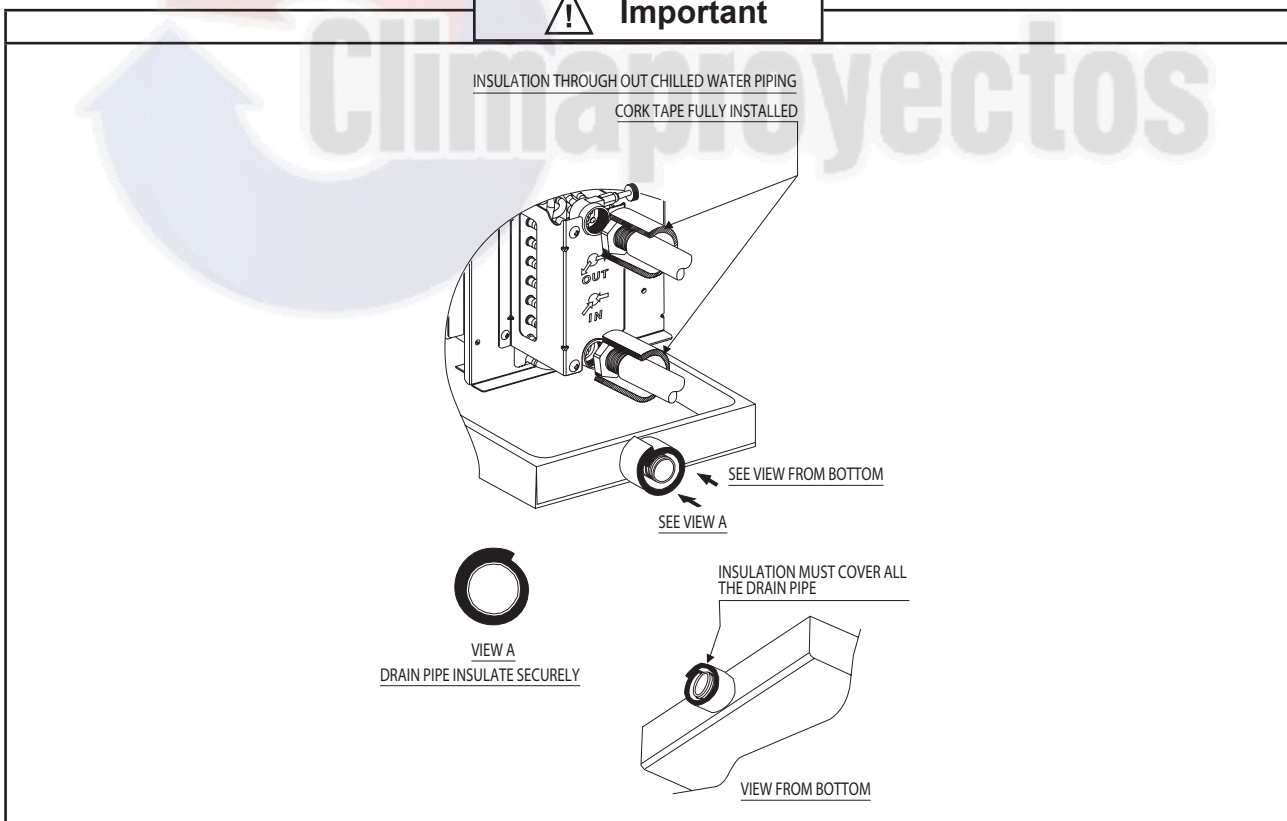

**Model: FUD**

**Mounting**

Ensure that the overhead supports are strong enough to hold the unit's weight. Position hanger rods and check for alignment with the unit. Check that hangers are secure and that the base of fan-coil unit is level in the two horizontal directions, taking into account the gradient recommended for drainage flow as shown. Check the gradient recommended for drainage flow as follow.

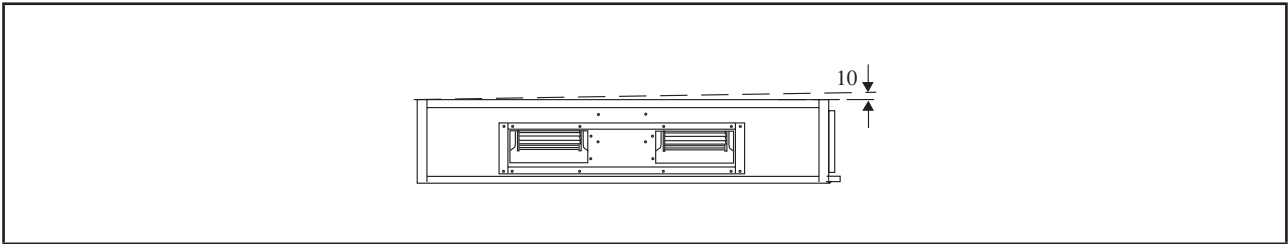

**FUD20/25B**

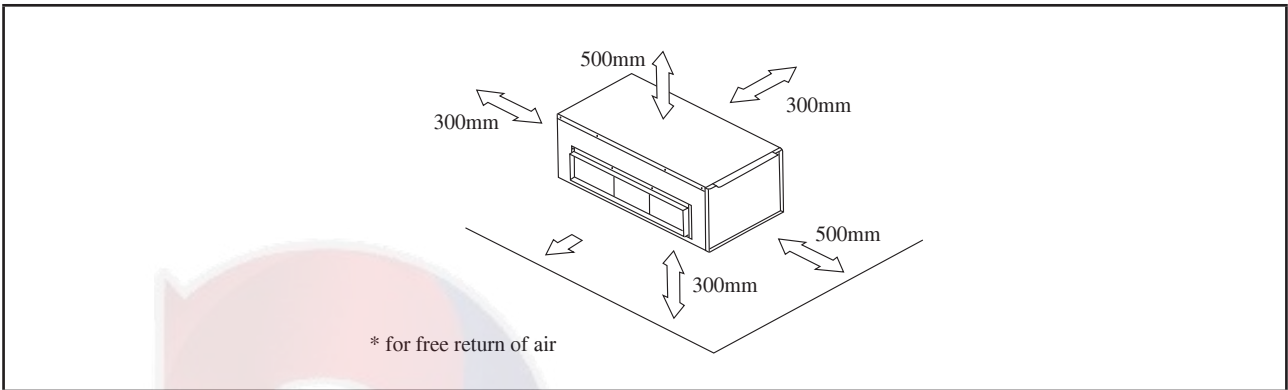

Provide clearance for servicing and optimal air flow as shown in the diagram. The indoor unit must be installed such that there is no short circuit of cool discharge with air discharge. Respect the installation clearance.

**FUD 30B (Horizontal)**

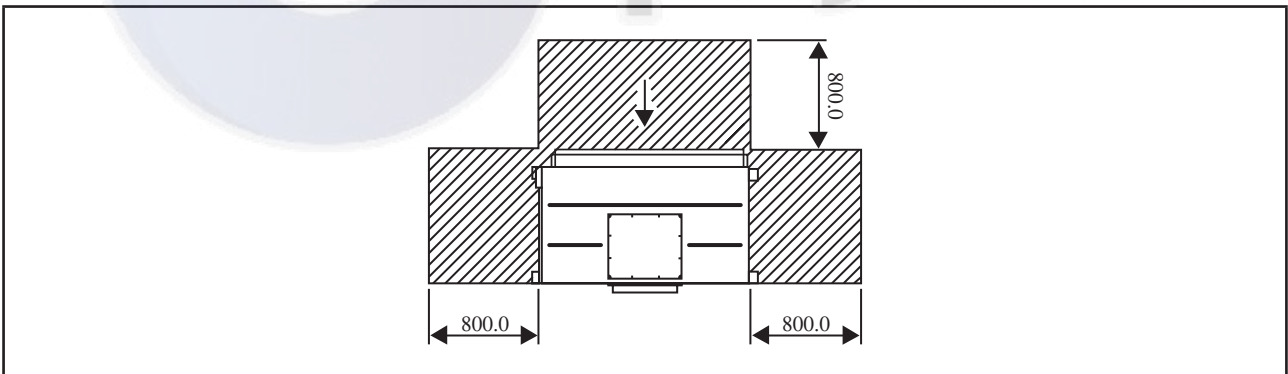

**FUD 30B (Vertical)**

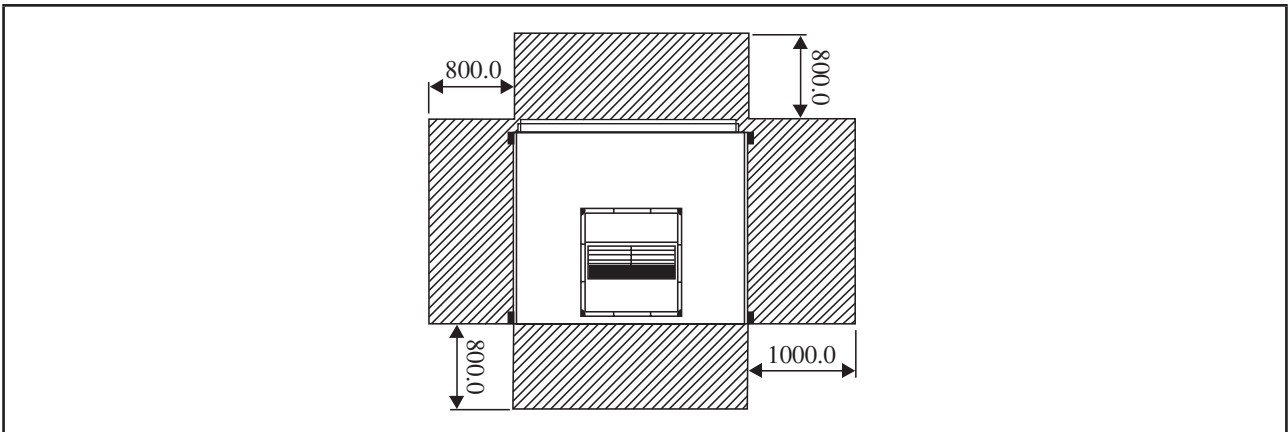

All dimensions in mm

Others

The controller board of 4 pipes system (W3) comes with other dry contact options.

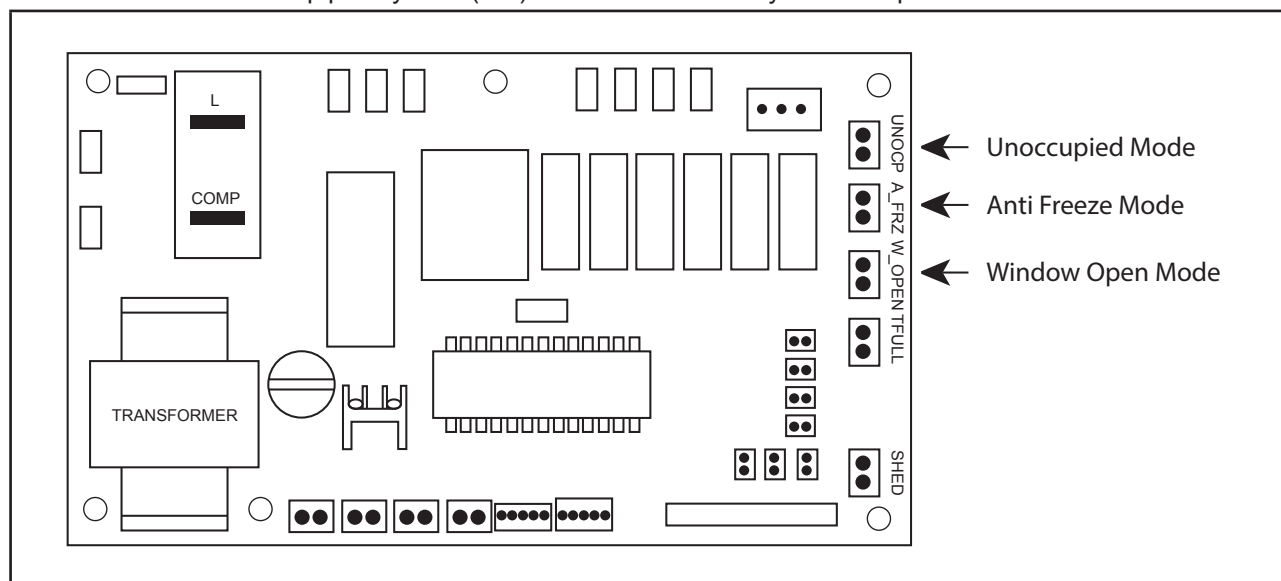

- i) **Unoccupied Mode**  
If the dry contact is closed, the Unoccupied mode is activated and vice versa. When Timer On is active, system goes back to Occupied mode.
- ii) **Anti Freeze Mode**  
Anti Freeze operation has the highest priority among all unit operation. Anti Freeze operation will be activated only if dry contact is closed and vice versa.
- iii) **Window Open Mode**  
If the dry contact is closed, Window Open Mode will be activated on the fan coil unit which is connected and vice versa.

Note: The dry contact connection point can be connected with individual fan coil unit only. It cannot be connected parallel with other fan coil units.

**Cable Size**

Model	Unit	FWKE / FWW
Power supply cable size*	mm2	1.5
Number of wire		3
Recommended fuse*	A	2

Model	Unit	FWC03C	FWC04C	FWC06C	FWC07C
Power supply cable size*	mm2	1.5	1.5	1.5	1.5
Number of wire		3	3	3	3
Recommended fuse*	A	1	1	1	2

Model	Unit	FWC09C	FWC11/12/14/16C	FWC-G
Power supply cable size*	mm2	1.5	1.5	1.0
Number of wire		3	3	5
Recommended fuse*	A	3	5	6

Model	Unit	FUD20/25B	FUD30/40B
Power supply cable size*	mm2	1.5	1.5
Number of wire		3	4
Recommended fuse*	A	10	10

**Important:** \* These values are for information only. They should be checked and selected to comply local or national codes and regulations. They are also subjected to the type of installation and size of conductor.



# Sound Data

## Sound Pressure Level

Model	Speed	1/1 Octave A-Weighted Sound Pressure (dBA), ref 20 $\mu$ Pa							Overall (dBA)	Noise Criteria
		125Hz	250Hz	500Hz	1kHz	2kHz	4kHz	8kHz		
FWW03L	High	32	33	33	30	27	18	8	35	29
	Med	26	29	29	26	21	11	6	30	24
	Low	20	24	25	20	16	6	5	25	20
FWW04L	High	43	40	39	37	35	29	16	42	36
	Med	39	37	36	34	31	23	11	39	33
	Low	32	31	31	28	24	14	8	32	26
FWW05L	High	36	39	40	38	34	30	12	42	36
	Med	32	36	37	34	29	24	9	38	33
	Low	27	33	34	29	24	18	7	34	29
FWW06L	High	42	41	41	42	39	39	18	48	41
	Med	38	38	39	38	35	29	14	42	37
	Low	35	36	36	35	31	25	10	39	34

Microphone position: 1m in front and 0.8m below the vertical centre line of the unit.

Model	Speed	1/1 Octave A-Weighted Sound Pressure (dBA), ref 20 $\mu$ Pa							Overall (dBA)	Noise Criteria
		125Hz	250Hz	500Hz	1kHz	2kHz	4kHz	8kHz		
FWKE05E(H)	High	39	39	37	28	18	11	6	37	32
	Med	36	33	31	20	8	6	6	31	25
	Low	28	26	23	12	4	5	6	23	16
	Quiet	21	17	13	6	4	5	6	16	0
*FWKE08E(H)	High	49	47	46	40	34	33	20	47	41
	Med	46	43	42	35	29	24	12	42	37
	Low	44	39	37	28	20	12	7	37	32
	Quiet	41	32	30	20	9	6	7	31	24
*FWKE11E(H)	High	53	50	50	45	38	36	25	51	46
	Med	49	45	46	40	33	30	17	46	41
	Low	42	40	41	33	26	19	8	41	36
	Quiet	39	34	34	25	14	7	6	34	29

Microphone position: 1.4m\*1.5m below the face center of the air return of the unit.

Model	Speed	1/1 Octave A-Weighted Sound Pressure (dBA), ref 20 $\mu$ Pa							Overall (dBA)	Noise Criteria
		125Hz	250Hz	500Hz	1kHz	2kHz	4kHz	8kHz		
FWC03C	High	43	35	35	30	26	18	13	36	30
	Med	42	32	32	27	23	15	10	33	26
	Low	40	27	27	23	18	9	4	29	22
FWC04C	High	46	40	40	33	29	21	17	40	35
	Med	43	36	36	29	25	15	12	36	31
	Low	38	31	31	24	18	8	5	31	25
FWC06C	High	47	41	43	35	31	24	19	42	38
	Med	47	40	40	34	30	22	17	41	35
	Low	47	35	28	29	24	15	9	35	28
FWC07C	High	48	41	40	35	31	24	19	41	35
	Med	46	38	38	33	28	21	16	39	33
	Low	44	35	35	29	24	16	11	36	30
*FWC09C	High	50	45	43	42	37	31	26	46	41
	Med	45	40	40	37	32	26	19	42	36
	Low	39	32	35	30	24	18	10	35	30
*FWC12C	High	54	47	47	45	39	35	29	49	44
	Med	47	41	43	39	33	29	21	44	38
	Low	41	36	39	34	27	23	14	39	34
*FWC14C	High	54	49	49	48	43	37	32	52	47
	Med	53	47	46	46	39	34	28	49	45
	Low	50	44	42	43	34	31	24	46	42
*FWC16C	High	55	49	49	50	44	37	33	53	49
	Med	54	48	48	48	42	35	31	51	47
	Low	52	45	46	45	37	32	26	48	44

Microphone position: 1.4/\*1.5m below the centre of the unit.  
(Tested with 2m length duct at the air discharge outlet and air return inlet).

Model (MSP)	Speed	1/1 Octave Sound Pressure Level (dBA, reference 20mPa)							Overall (dBA)	Noise Criteria
		125 Hz	250 Hz	500 Hz	1000 Hz	2000 Hz	4000 Hz	8000 Hz		
FWC03G	High	46	36	33	31	24	16	10	36	30
	Med	42	30	27	24	15	9	9	30	23
	Low	35	21	16	13	8	8	7	22	0
FWC04G	High	40	38	37	32	28	20	15	38	32
	Med	37	34	31	26	20	13	10	32	25
	Low	27	25	22	16	9	9	9	23	0
FWC06G	High	47	44	40	36	31	22	13	42	35
	Med	44	40	37	32	26	16	10	38	32
	Low	38	34	31	26	18	10	10	32	25
FWC08G	High	49	45	42	37	33	27	18	44	37
	Med	45	41	36	31	26	19	11	38	31
	Low	39	33	30	23	16	12	9	31	24
FWC10G	High	52	47	42	38	33	26	19	45	37
	Med	49	43	39	34	29	22	13	41	34
	Low	42	37	32	27	21	12	9	34	26
FWC12G	High	49	46	43	40	34	26	18	45	39
	Med	45	42	41	35	29	19	11	41	36
	Low	43	40	36	33	25	14	10	38	32
FWC14G	High	54	49	46	41	38	32	26	48	41
	Med	51	45	42	38	34	27	20	44	37
	Low	43	36	36	29	23	15	8	36	31
FWC16G	High	57	51	46	42	37	32	29	49	41
	Med	54	48	43	38	33	27	22	45	38
	Low	48	40	37	30	25	16	10	38	32
FWC18G	High	58	52	46	43	42	36	33	50	43
	Med	55	48	43	38	36	32	28	46	39
	Low	52	41	36	32	30	24	18	40	35
FWC20G	High	58	53	47	45	40	35	32	51	44
	Med	56	50	44	40	35	30	27	47	40
	Low	50	41	36	32	27	19	14	39	33

Microphone position: 1.5m below the centre of the unit.

(Tested with 2m length duct at the air discharge outlet and 1m length of air return duct).

Model EC (LSP)	Speed	1/1 Octave Sound Pressure Level (dB, reference 20mPa)							Overall (dBA)	Noise Criteria
		125 Hz	250 Hz	500 Hz	1000 Hz	2000 Hz	4000 Hz	8000 Hz		
FWC02G	High	41	33	29	25	17	10	9	31	23
	Med	35	28	24	19	9	8	8	26	0
	Low	29	23	18	12	8	8	7	20	0
FWC03G	High	36	34	29	28	18	11	9	32	26
	Med	28	27	23	19	9	8	8	25	0
	Low	26	20	16	15	8	8	8	20	0
FWC04G	High	40	36	32	30	23	16	9	35	29
	Med	35	31	27	25	16	9	8	29	23
	Low	27	24	19	13	9	9	8	21	0
FWC06G	High	45	40	35	32	28	22	13	38	31
	Med	43	36	32	29	25	19	11	35	28
	Low	40	30	28	25	18	10	8	30	23
FWC08G	High	45	41	37	33	28	20	12	39	32
	Med	41	37	32	27	21	12	11	34	26
	Low	35	29	25	18	11	10	10	26	0
FWC10G	High	47	44	38	35	30	22	16	41	34
	Med	45	39	35	30	24	15	9	37	30
	Low	44	33	27	22	15	8	8	31	25
FWC12G	High	47	43	40	37	32	23	15	42	36
	Med	44	40	37	34	28	19	9	39	33
	Low	41	36	33	30	23	12	8	35	29

Microphone position: 1.5m below the centre of the unit.

(Tested with 2m length duct at the air discharge outlet and 1m length of air return duct).

Model EC (MSP)	Speed	1/1 Octave Sound Pressure Level (dB, reference 20mPa)							Overall (dBA)	Noise Criteria
		125 Hz	250 Hz	500 Hz	1000 Hz	2000 Hz	4000 Hz	8000 Hz		
FWC03G	High	37	36	34	30	23	15	5	35	29
	Med	32	30	28	24	16	5	5	29	22
	Low	24	22	20	12	7	7	6	20	0
FWC04G	High	37	37	36	32	28	21	12	37	31
	Med	32	31	30	26	20	12	5	31	24
	Low	25	22	22	15	8	5	5	22	0
FWC06G	High	46	41	39	36	30	24	15	41	35
	Med	41	37	37	32	25	18	9	37	32
	Low	38	32	31	25	17	9	4	31	25
FWC08G	High	47	43	41	38	32	26	15	43	37
	Med	43	38	36	32	25	17	6	37	31
	Low	37	31	30	24	16	6	5	30	24
FWC10G	High	48	44	42	39	33	26	18	44	38
	Med	47	41	38	34	28	20	10	40	33
	Low	43	33	32	26	18	7	5	33	26
FWC12G	High	48	44	43	39	33	26	18	44	38
	Med	43	40	39	35	29	21	12	40	34
	Low	40	38	36	32	24	15	6	37	31

Microphone position: 1.5m below the centre of the unit.

(Tested with 2m length duct at the air discharge outlet and 1m length of air return duct).

Model	Speed	1/1 Octave A-Weighted Sound Pressure (dBA), ref 20µPa							Overall (dBA)	Noise Criteria
		125Hz	250Hz	500Hz	1kHz	2kHz	4kHz	8kHz		
FUD20B	High	57	50	47	44	40	35	24	50	43
	Med	57	46	44	40	35	30	17	46	41
	Low	48	42	41	35	30	24	6	42	36
FUD25B	High	57	53	50	50	44	40	31	54	49
	Med	55	51	49	48	42	38	28	52	47
	Low	54	50	48	46	40	35	25	50	45
FUD30B	High	57	55	56	53	51	46	38	58	53

Microphone position: 1.5m below the centre of the unit.  
 (Tested with 2m length duct at the air discharge outlet and 1m length of air return inlet).



## Sound Power Level

Model	Speed	1/1 Octave Sound Power Level (dBA, reference 1pW)							Overall A (dBA)
		125Hz	250Hz	500Hz	1kHz	2kHz	4kHz	8kHz	
FWW03L	High	42	45	46	43	38	27	18	47
	Med	39	42	42	39	32	20	17	43
	Low	37	39	38	34	30	15	17	39
FWW04L	High	45	51	52	51	46	39	27	54
	Med	42	47	49	46	41	32	20	50
	Low	35	43	44	41	34	22	17	45
FWW05L	High	48	52	53	52	43	36	23	55
	Med	44	50	50	49	38	31	19	52
	Low	41	48	48	46	34	26	18	49
FWW06L	High	52	54	55	55	49	41	29	58
	Med	50	53	54	54	45	38	25	57
	Low	46	50	52	51	41	34	21	54

Measured In Reverberation Chamber

Model	Speed	1/1 Octave Sound Power Level (dBA, reference 1pW)							Overall A (dBA)
		125Hz	250Hz	500Hz	1kHz	2kHz	4kHz	8kHz	
FWKE05E(H)	High	49	50	45	36	26	20	19	46
	Med	46	44	39	28	16	15	18	40
	Low	38	40	32	22	14	15	20	34
	Quiet	33	38	24	15	10	14	18	30
FWKE08E(H)	High	59	58	56	50	42	42	30	67
	Med	54	54	51	44	37	34	23	52
	Low	57	55	45	37	29	22	25	49
	Quiet	50	44	39	29	17	15	19	40
FWKE11E(H)	High	63	60	58	53	45	46	34	59
	Med	60	55	54	48	40	40	27	55
	Low	58	50	49	41	34	29	20	49
	Quiet	53	45	42	33	22	16	19	43

Measured In Reverberation Chamber

Model	Speed	1/1 Octave Sound Power Level (dBA, reference 1pW)							Overall A (dBA)
		125Hz	250Hz	500Hz	1kHz	2kHz	4kHz	8kHz	
FWC03C	High	57	54	52	52	51	46	44	57
	Med	52	49	48	47	45	40	36	52
	Low	44	41	42	39	36	31	25	44
FWC04C	High	60	58	57	56	54	48	44	61
	Med	54	53	52	51	48	41	38	55
	Low	48	47	46	45	40	33	30	49
FWC06C	High	63	62	61	61	59	55	51	65
	Med	59	58	57	58	55	50	46	62
	Low	40	38	42	41	35	28	24	44
FWC07C	High	63	62	61	62	59	56	53	66
	Med	61	60	59	60	57	53	50	64
	Low	57	56	55	56	53	48	46	60
*FWC09C	High	65	66	68	69	65	63	60	73
	Med	60	61	63	64	60	57	54	68
	Low	53	55	57	58	54	49	45	61
FWC12C	High	65	68	70	72	68	66	64	76
	Med	62	63	65	66	62	61	57	70
	Low	58	59	61	61	57	56	50	65
FWC14C	High	67	69	71	72	69	66	64	76
	Med	65	66	68	69	65	62	60	73
	Low	62	62	65	65	60	58	55	69
FWC16C	High	69	70	72	74	71	69	68	78
	Med	69	69	71	72	69	67	66	76
	Low	66	67	69	69	65	63	61	73

Measured In Reverberation Chamber

Model	Speed	1/1 Octave Sound Power Level (dBA, reference 1pW)							Overall A (dBA)
		125Hz	250Hz	500Hz	1kHz	2kHz	4kHz	8kHz	
FWC03G	High	56	55	57	57	53	48	39	60
	Med	51	49	51	51	45	39	29	54
	Low	47	43	43	40	32	23	23	44
FWC04G	High	59	57	58	59	55	50	43	62
	Med	54	52	54	54	49	43	34	57
	Low	50	45	46	43	36	28	21	47
FWC06G	High	62	61	61	61	57	54	48	65
	Med	58	58	58	58	53	50	43	61
	Low	53	52	53	52	46	42	33	55
FWC08G	High	63	62	62	62	57	53	46	65
	Med	57	57	58	57	52	47	38	60
	Low	52	51	51	50	43	36	29	53
FWC10G	High	63	63	63	63	59	55	49	67
	Med	59	59	59	59	54	49	42	63
	Low	54	53	54	53	47	40	32	56
FWC12G	High	65	65	64	64	59	56	49	68
	Med	62	61	61	61	55	51	43	64
	Low	59	58	57	57	51	45	37	60
FWC14G	High	67	69	69	67	62	61	58	71
	Med	64	64	65	63	58	56	51	67
	Low	58	58	59	56	50	46	40	60
FWC16G	High	70	71	69	69	64	63	61	73
	Med	66	66	66	64	59	58	54	68
	Low	60	59	59	56	51	47	42	61
FWC18G	High	71	72	70	70	65	64	62	74
	Med	68	68	67	66	61	60	57	71
	Low	63	61	62	59	54	52	47	64
FWC20G	High	72	74	72	72	67	67	65	76
	Med	68	68	69	67	62	61	59	71
	Low	62	61	61	59	54	51	46	63

Measured In Reverberation Chamber



Model EC (LSP)	Speed	1/1 Octave Sound Power Level (dB, reference 1pW)							Overall (dBA)
		125 Hz	250 Hz	500 Hz	1000 Hz	2000 Hz	4000 Hz	8000 Hz	
FWC02G	High	61	52	54	54	47	41	32	57
	Med	53	49	51	50	42	35	29	53
	Low	47	45	46	44	35	26	21	47
FWC03G	High	56	55	57	57	51	47	37	60
	Med	55	51	52	51	45	39	28	55
	Low	49	43	44	41	33	24	23	45
FWC04G	High	58	58	59	59	54	49	40	62
	Med	55	55	56	55	49	43	33	58
	Low	47	47	47	44	37	28	21	48
FWC06G	High	60	60	60	59	54	51	44	63
	Med	59	58	58	57	52	48	40	61
	Low	54	54	54	53	46	42	33	56
FWC08G	High	60	60	60	58	53	49	41	62
	Med	57	56	56	55	48	43	34	58
	Low	50	50	50	47	39	32	25	51
FWC10G	High	62	62	62	61	57	53	46	65
	Med	59	59	60	59	53	48	41	62
	Low	54	54	55	54	47	41	31	57
FWC12G	High	64	62	62	61	56	52	44	65
	Med	61	60	60	58	52	48	40	62
	Low	58	56	57	54	48	42	33	58

Microphone position: 1.5m below the centre of the unit.

(Tested with 2m length duct at the air discharge outlet and 1m length of air return duct).

Model EC (MSP)	Speed	1/1 Octave Sound Power Level (dB, reference 1pW)							Overall (dBA)
		125 Hz	250 Hz	500 Hz	1000 Hz	2000 Hz	4000 Hz	8000 Hz	
FWC03G	High	55	55	58	58	53	48	40	61
	Med	50	51	53	52	47	41	32	56
	Low	44	43	45	41	34	27	27	46
FWC04G	High	58	58	59	58	54	50	43	62
	Med	54	54	55	54	49	44	36	58
	Low	47	45	47	45	37	30	27	48
FWC06G	High	60	60	62	61	56	52	45	65
	Med	57	58	60	59	53	48	41	62
	Low	54	54	56	55	48	42	34	58
FWC08G	High	61	62	62	62	57	52	45	65
	Med	57	58	59	58	52	47	39	61
	Low	52	51	53	51	43	37	30	54
FWC10G	High	61	63	64	65	60	55	49	68
	Med	58	60	61	61	56	51	43	64
	Low	53	54	56	55	49	42	34	58
FWC12G	High	73	65	65	64	59	55	50	68
	Med	65	61	61	61	56	50	42	64
	Low	61	58	59	58	52	46	37	61

Microphone position: 1.5m below the centre of the unit.

(Tested with 2m length duct at the air discharge outlet and 1m length of air return duct).

Model	Speed	1/1 Octave Sound Power Level (dBA, reference 1pW)							Overall A (dBA)
		125Hz	250Hz	500Hz	1kHz	2kHz	4kHz	8kHz	
FUD20B	High	68	67	72	70	65	65	57	74
	Med	64	64	68	65	61	59	51	69
	Low	61	60	63	60	56	53	43	65
FUD25B	High	71	71	74	74	70	70	63	78
	Med	70	69	73	72	68	68	60	76
	Low	67	67	71	69	65	64	56	73
FUD30B	High	75	76	75	72	69	65	60	77

Measured In Reverberation Chamber



### NC Curve

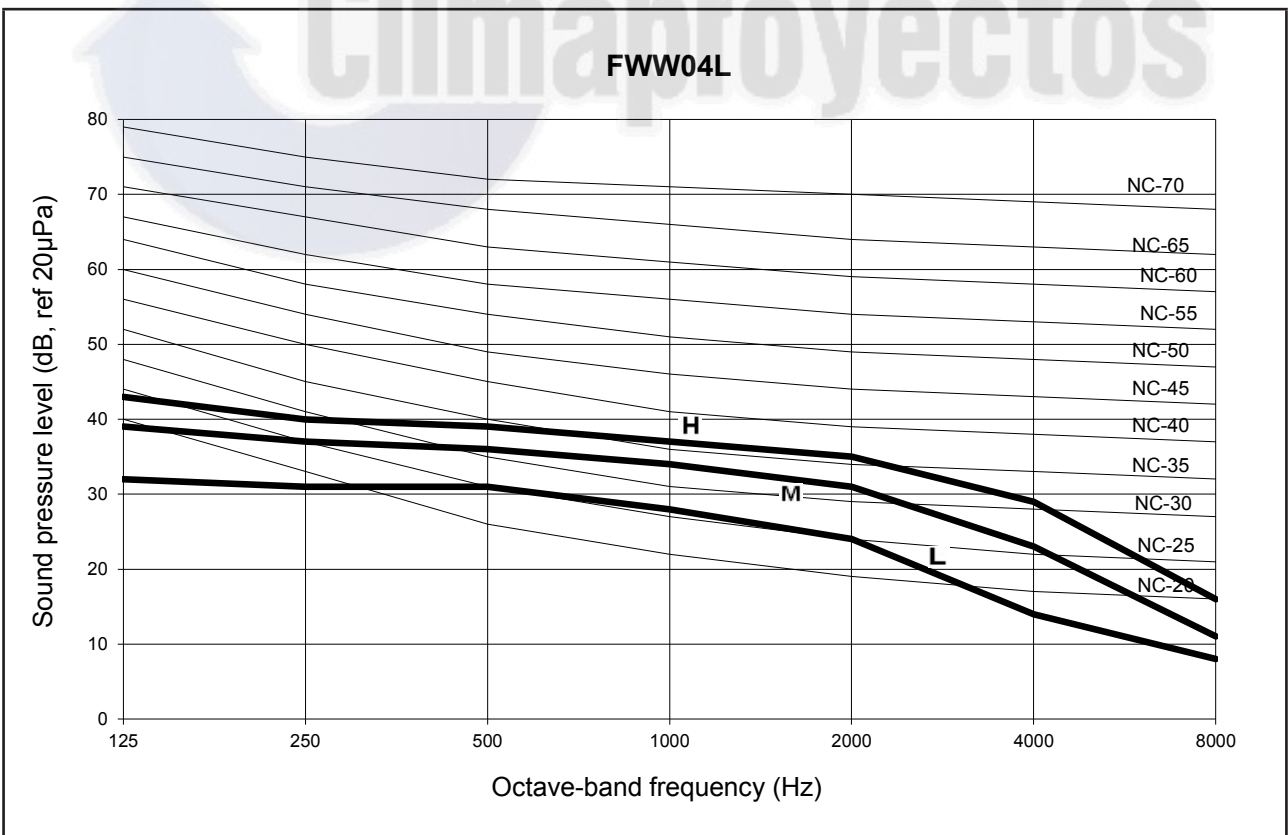
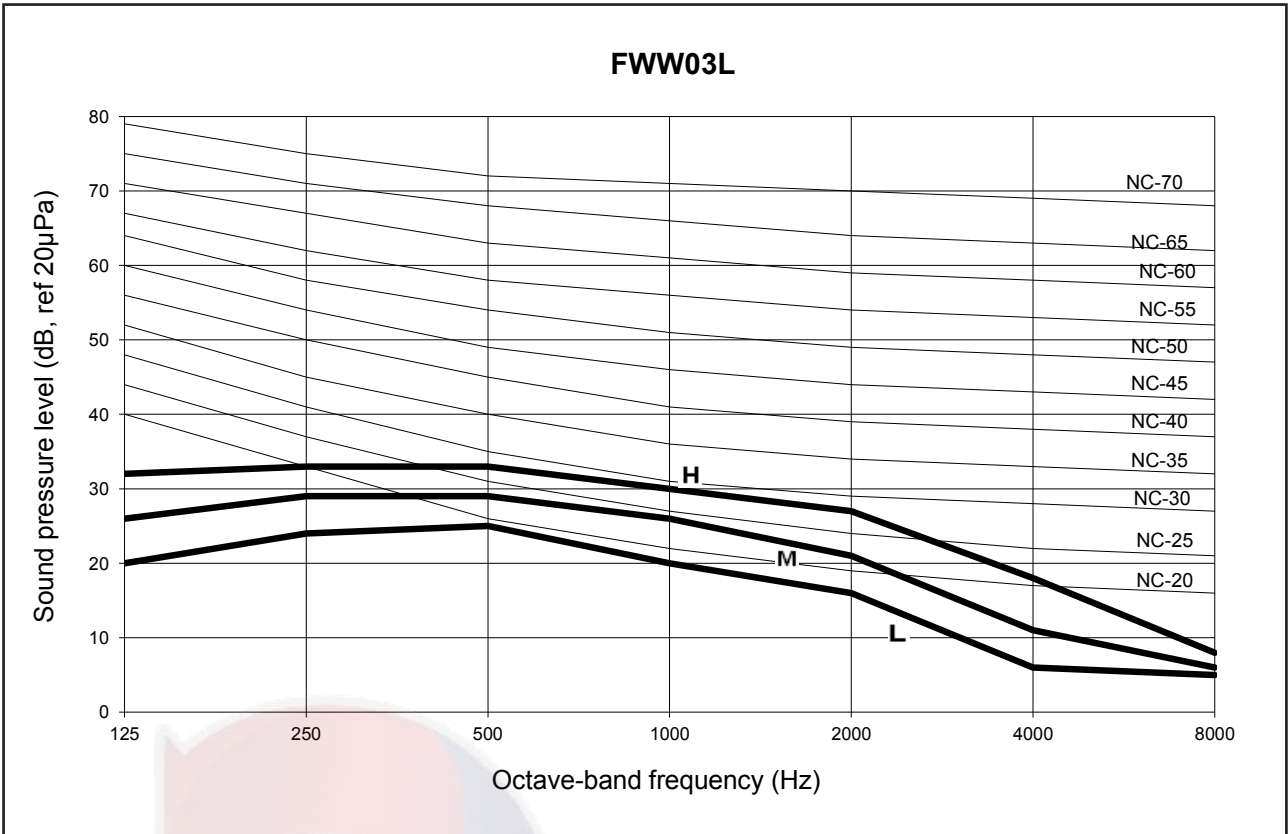

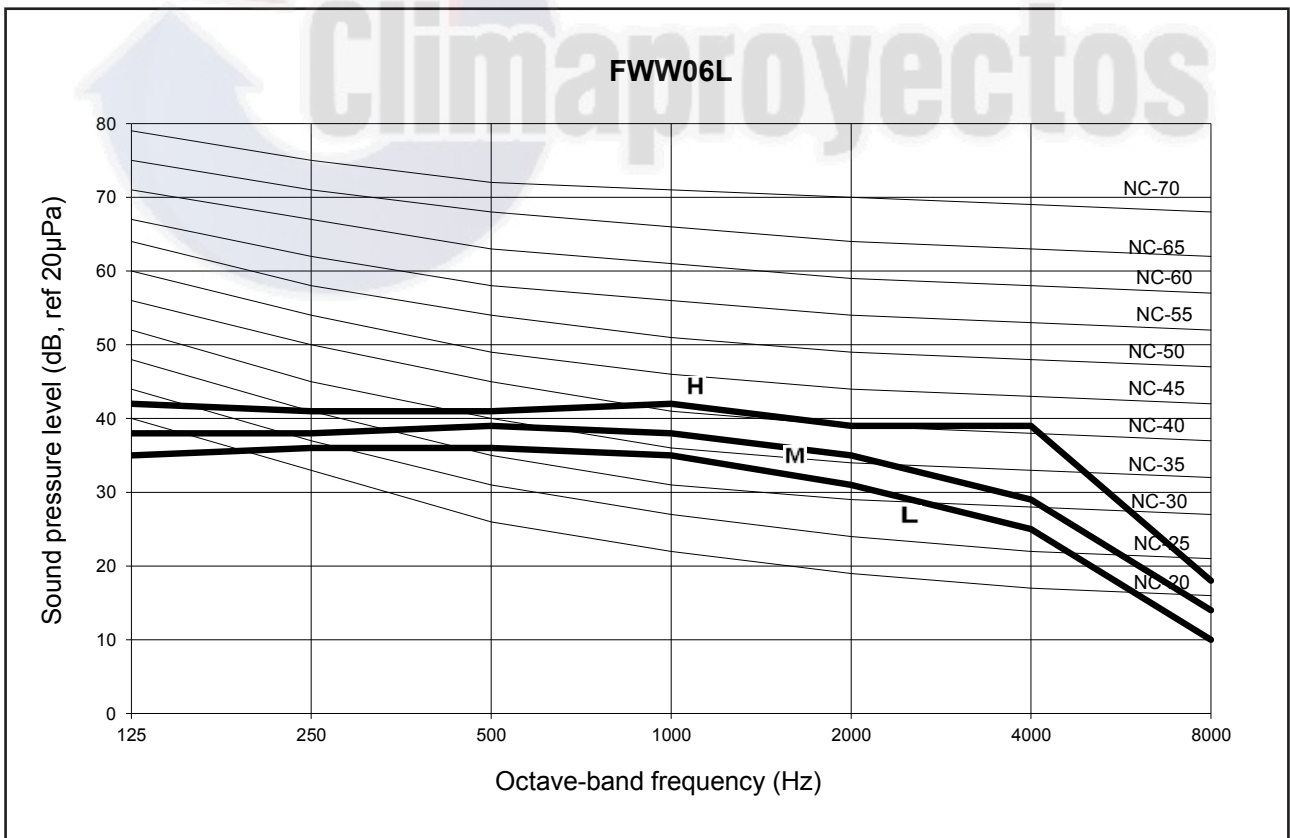
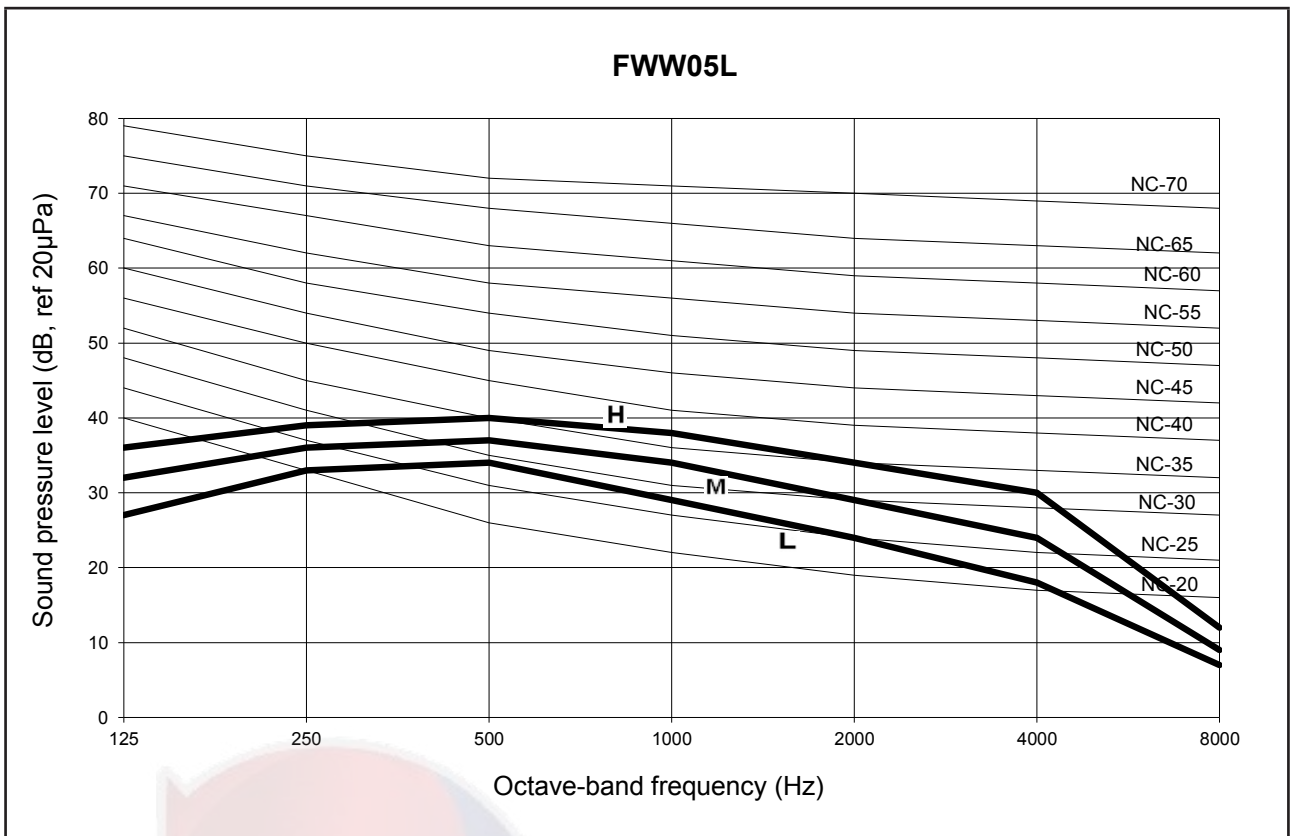

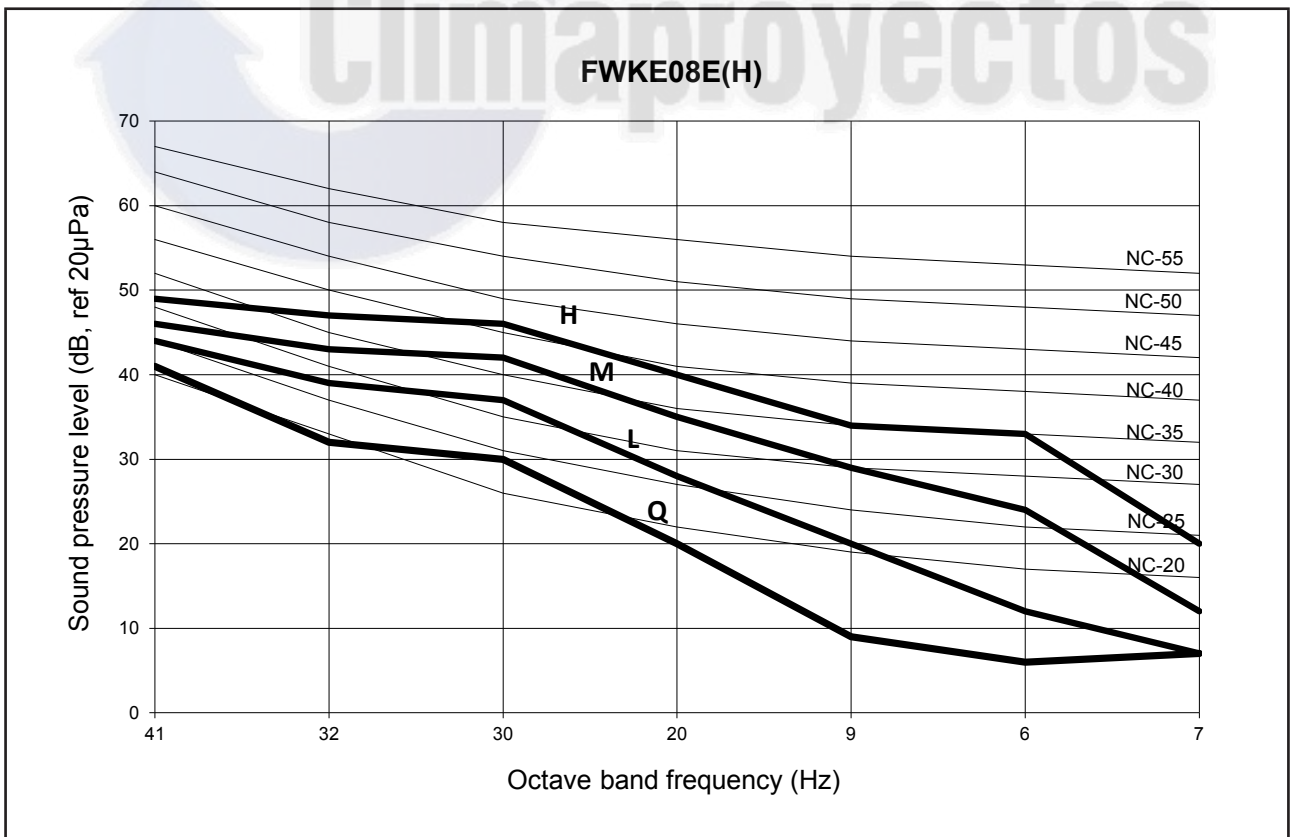
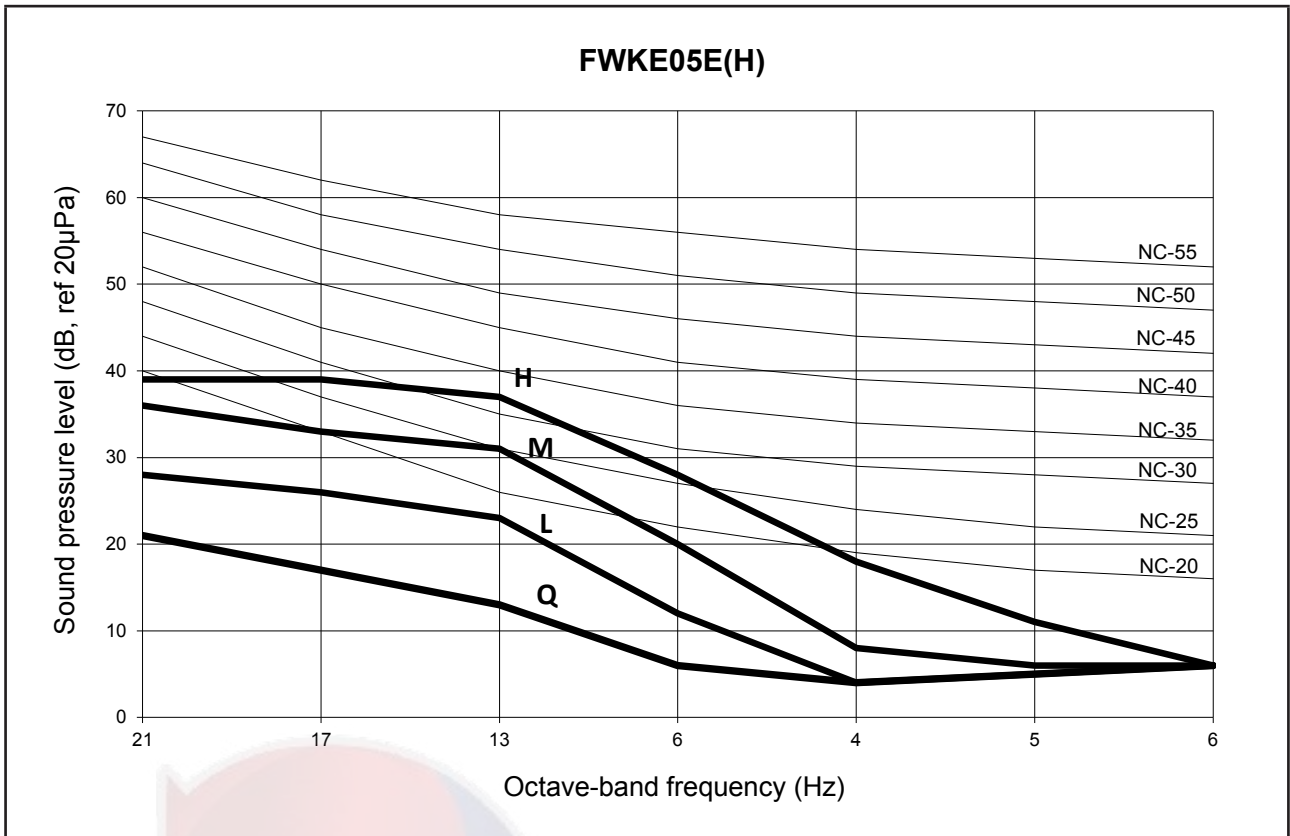

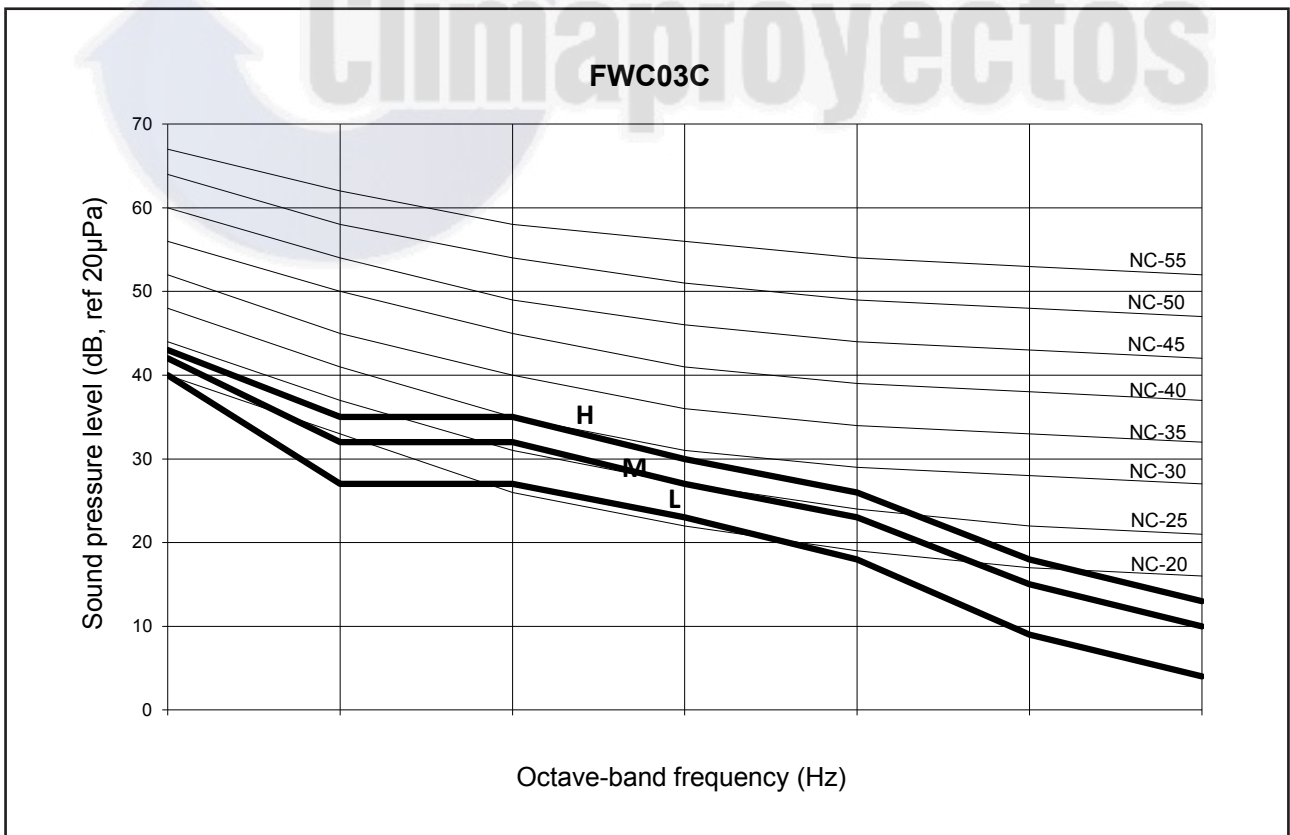
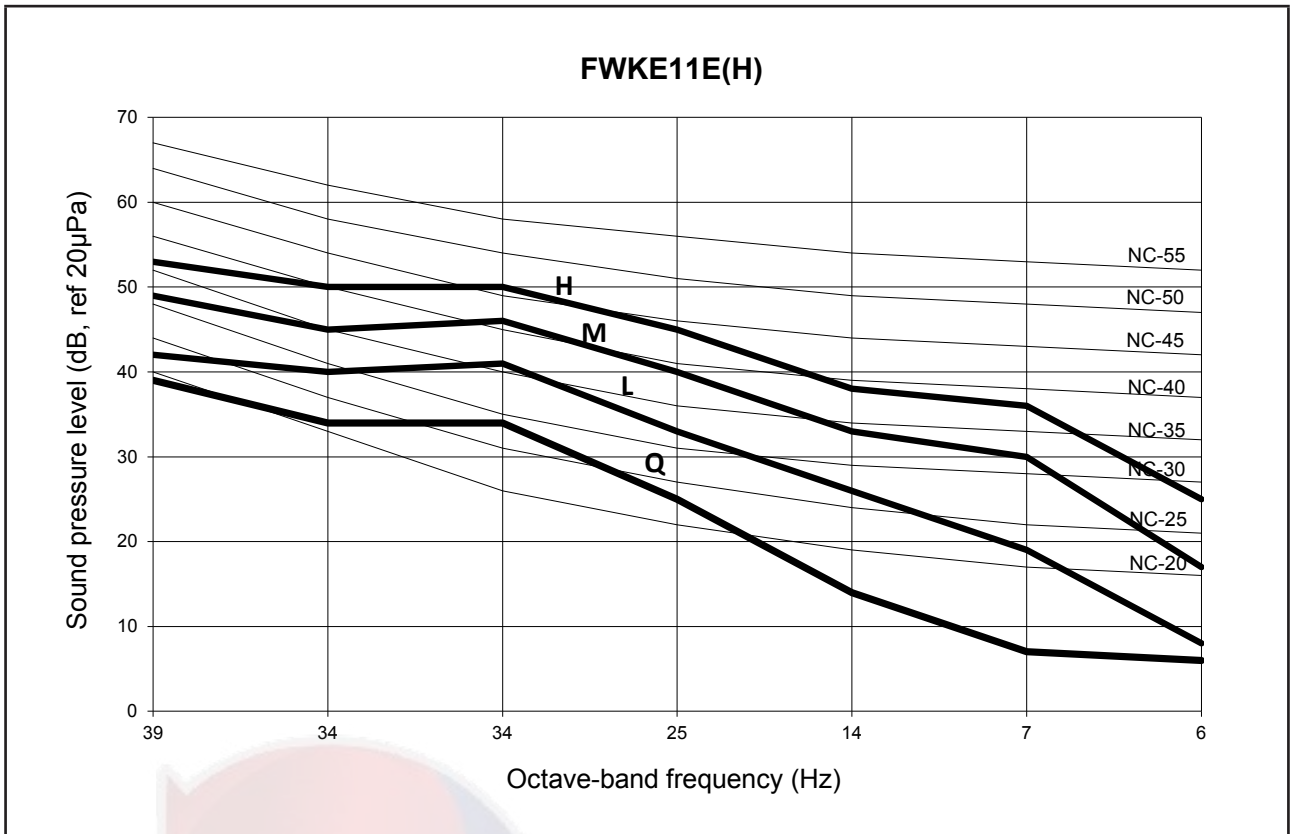

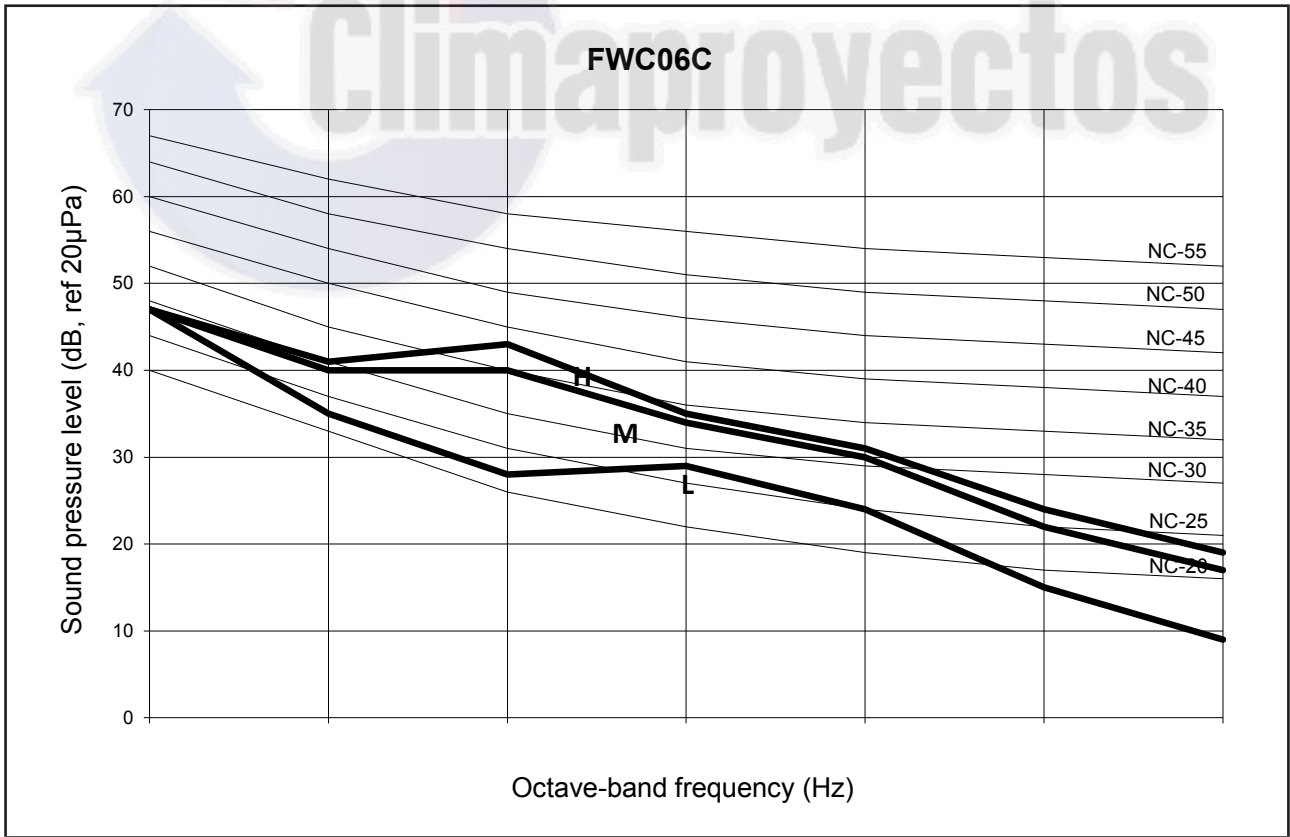
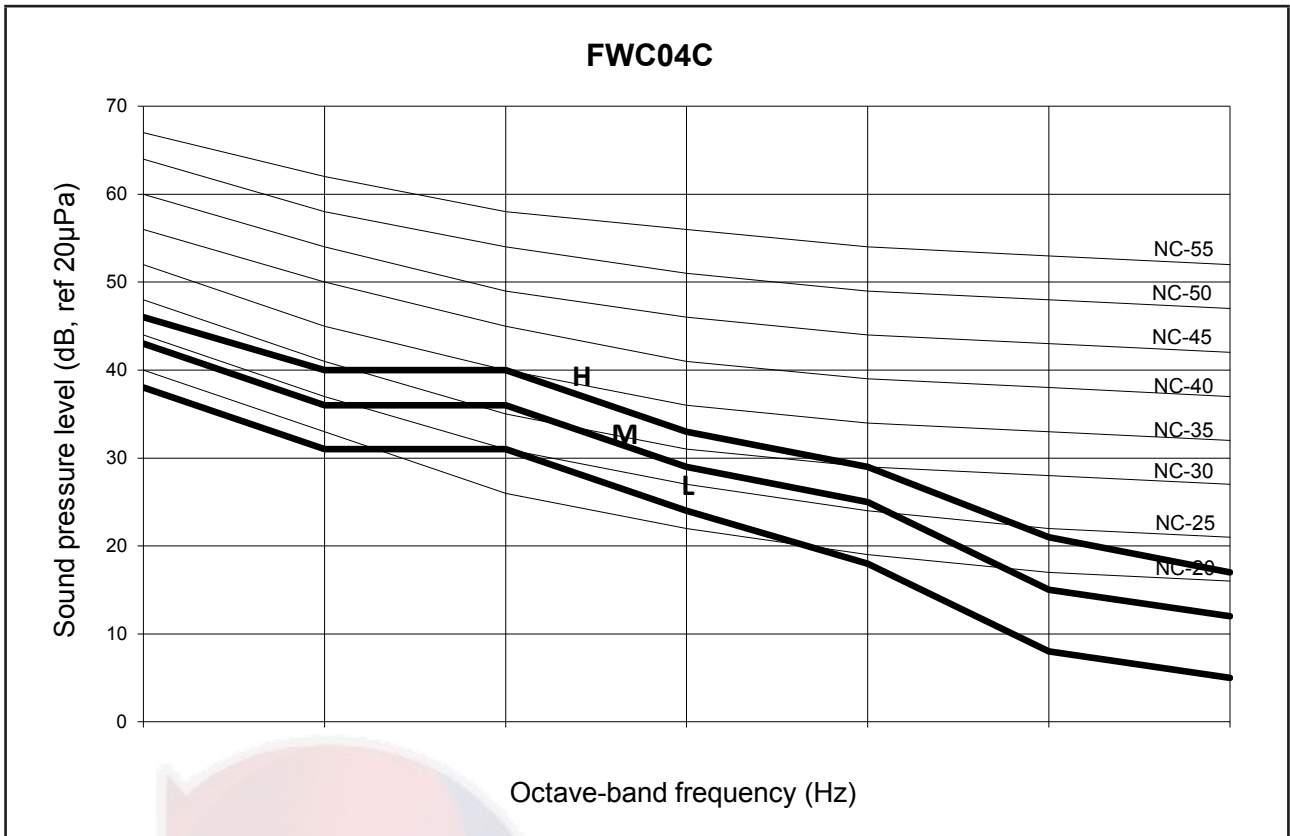

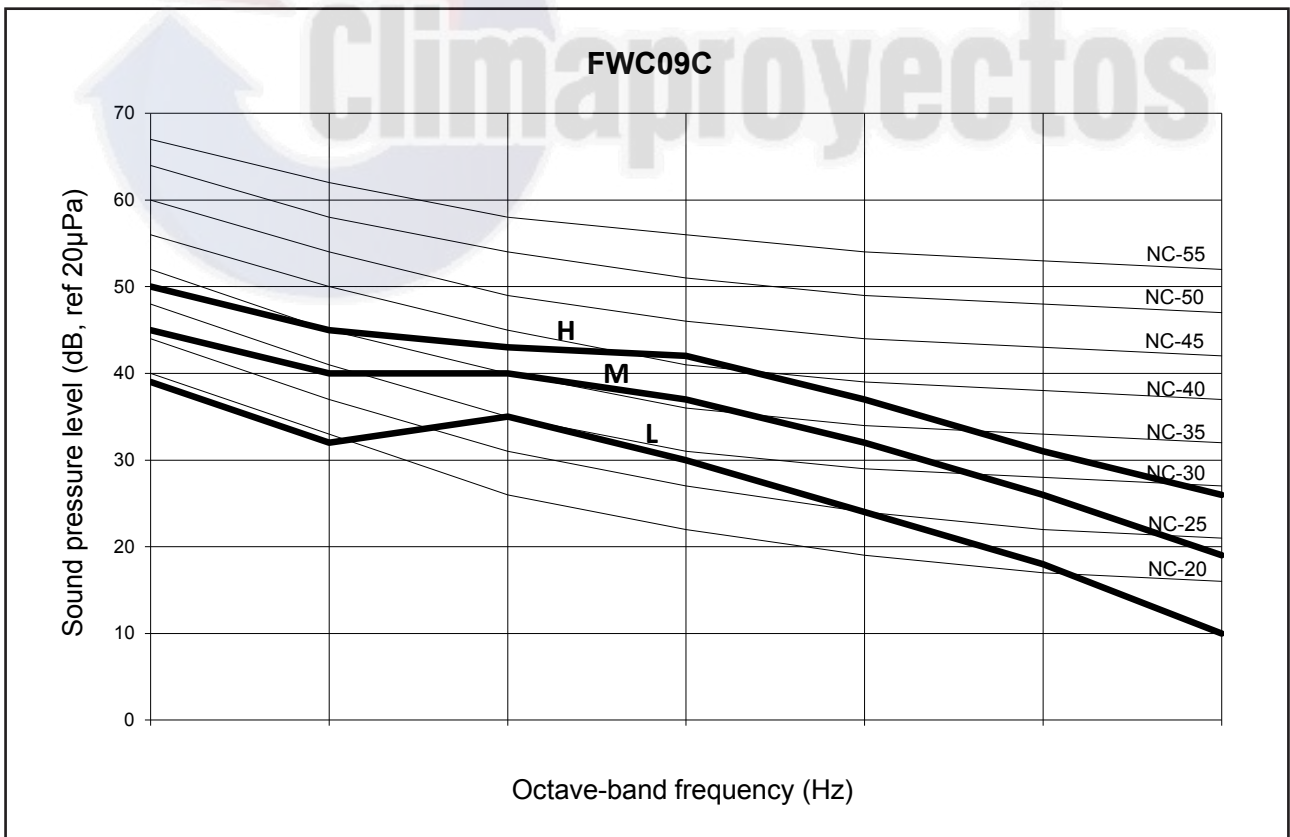
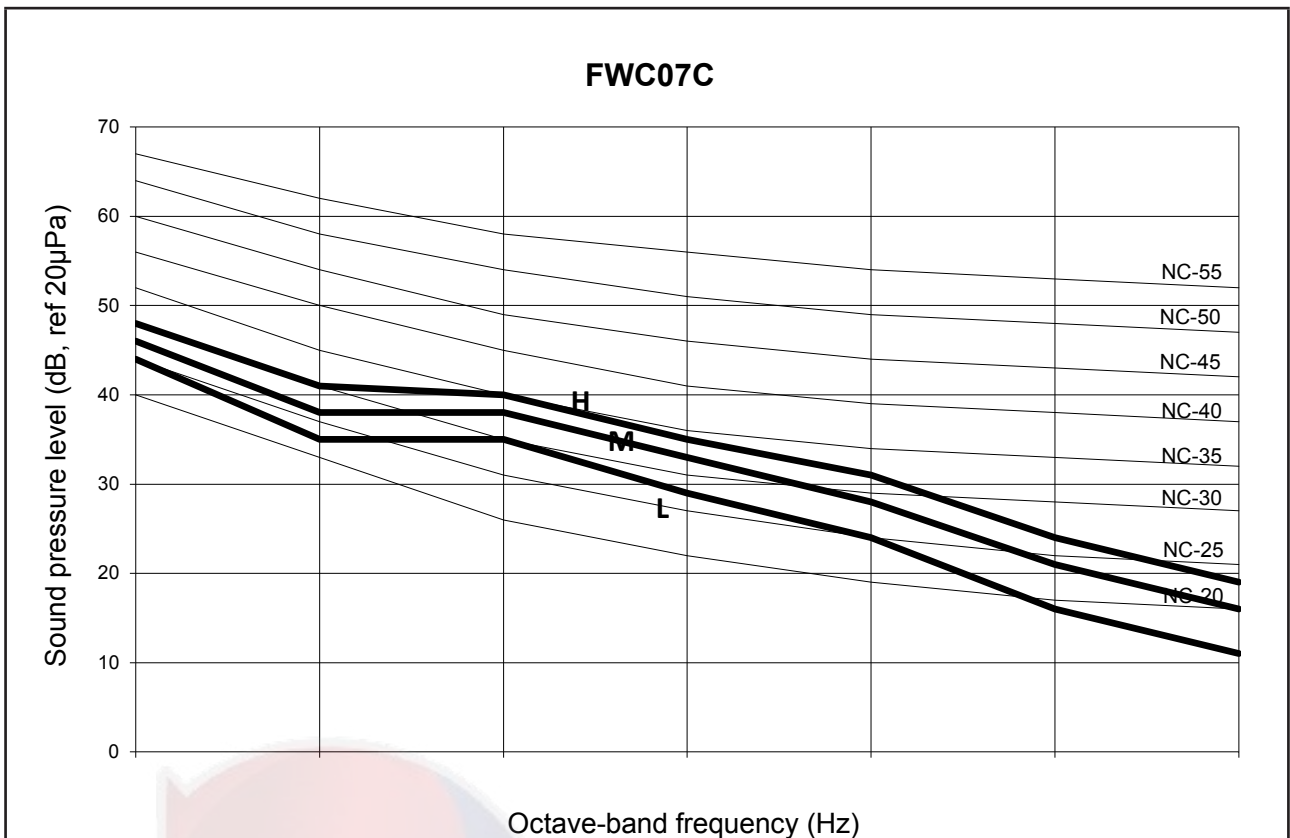



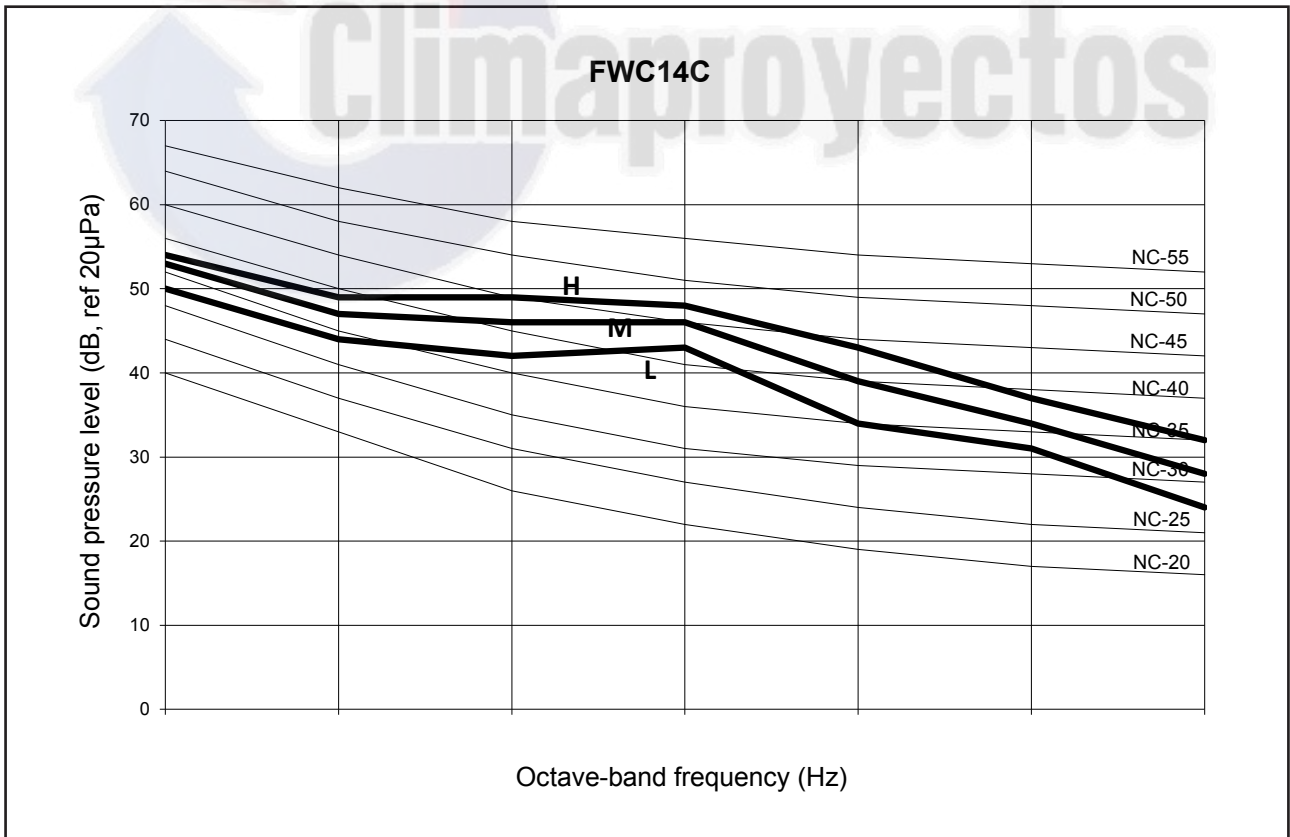
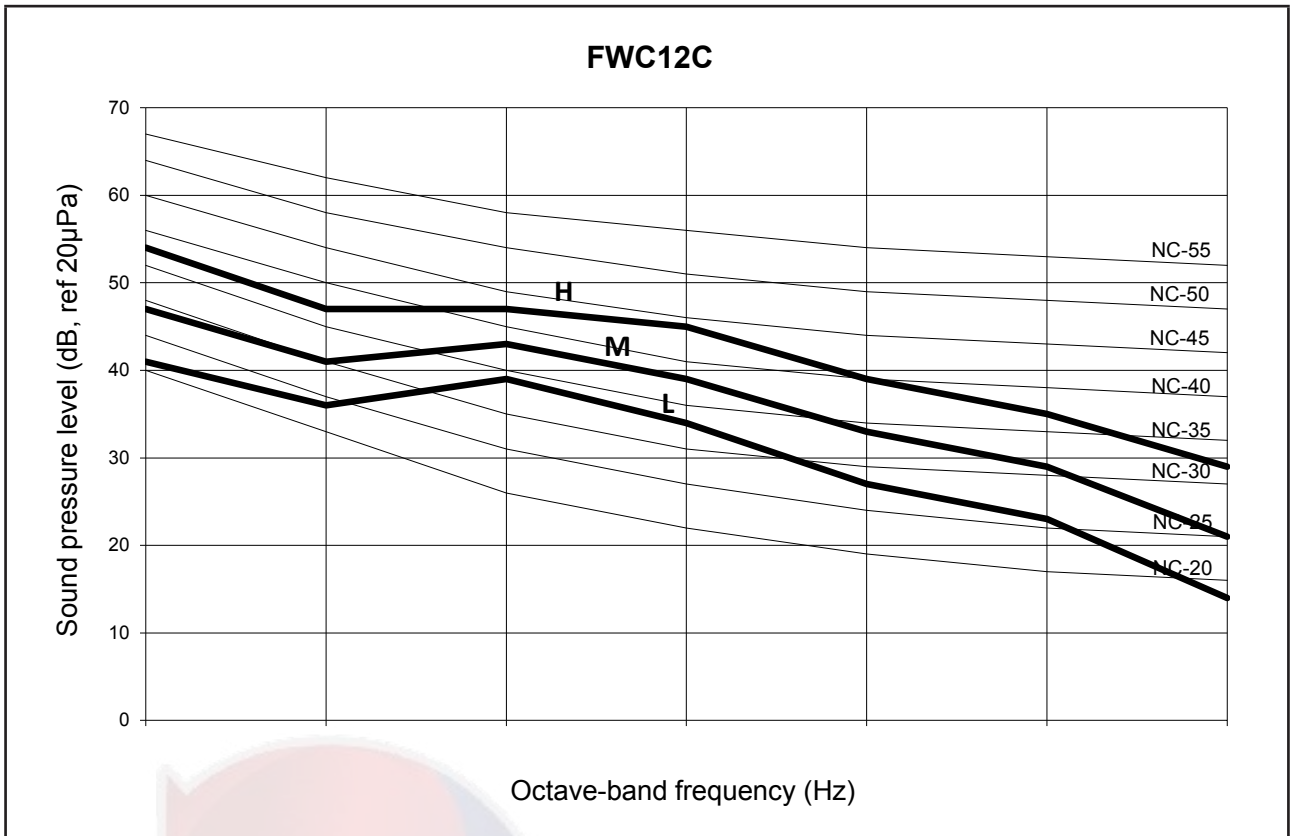

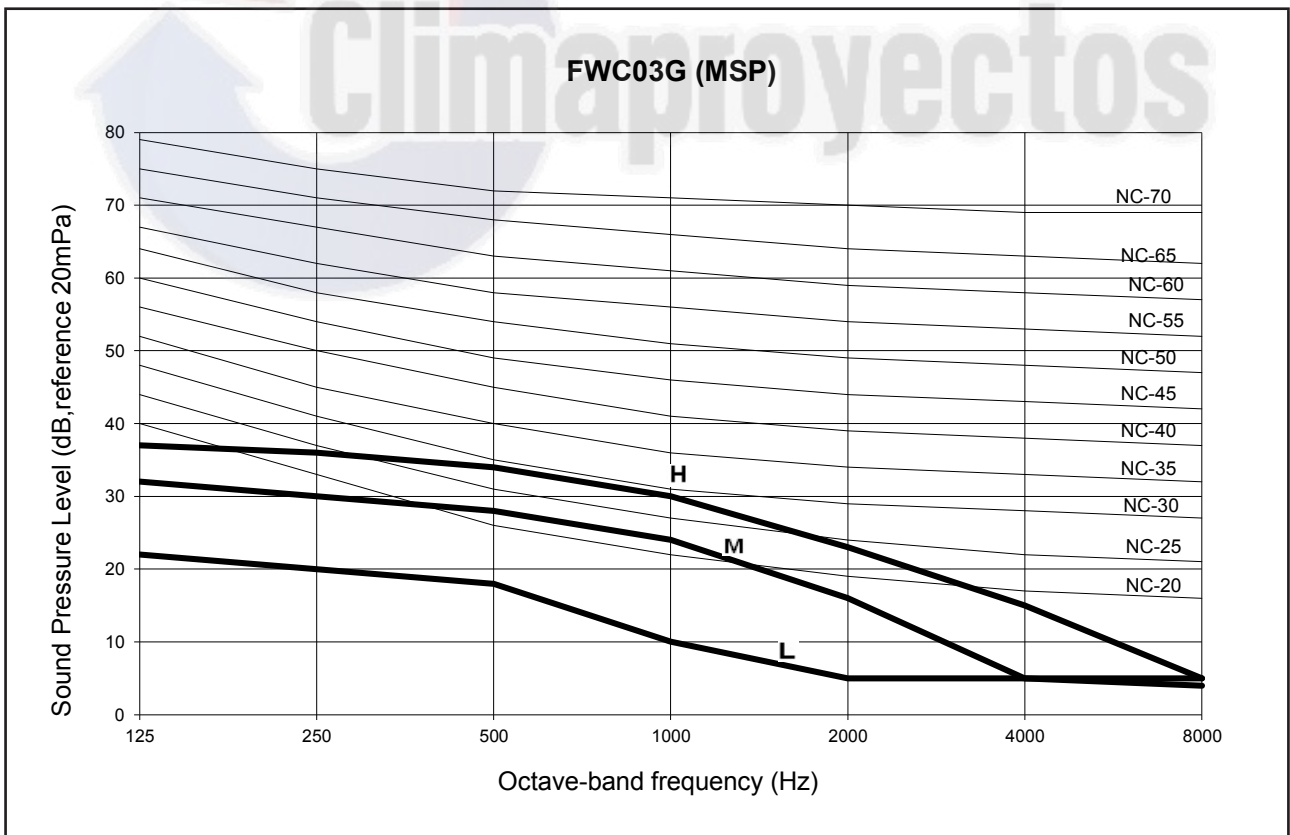
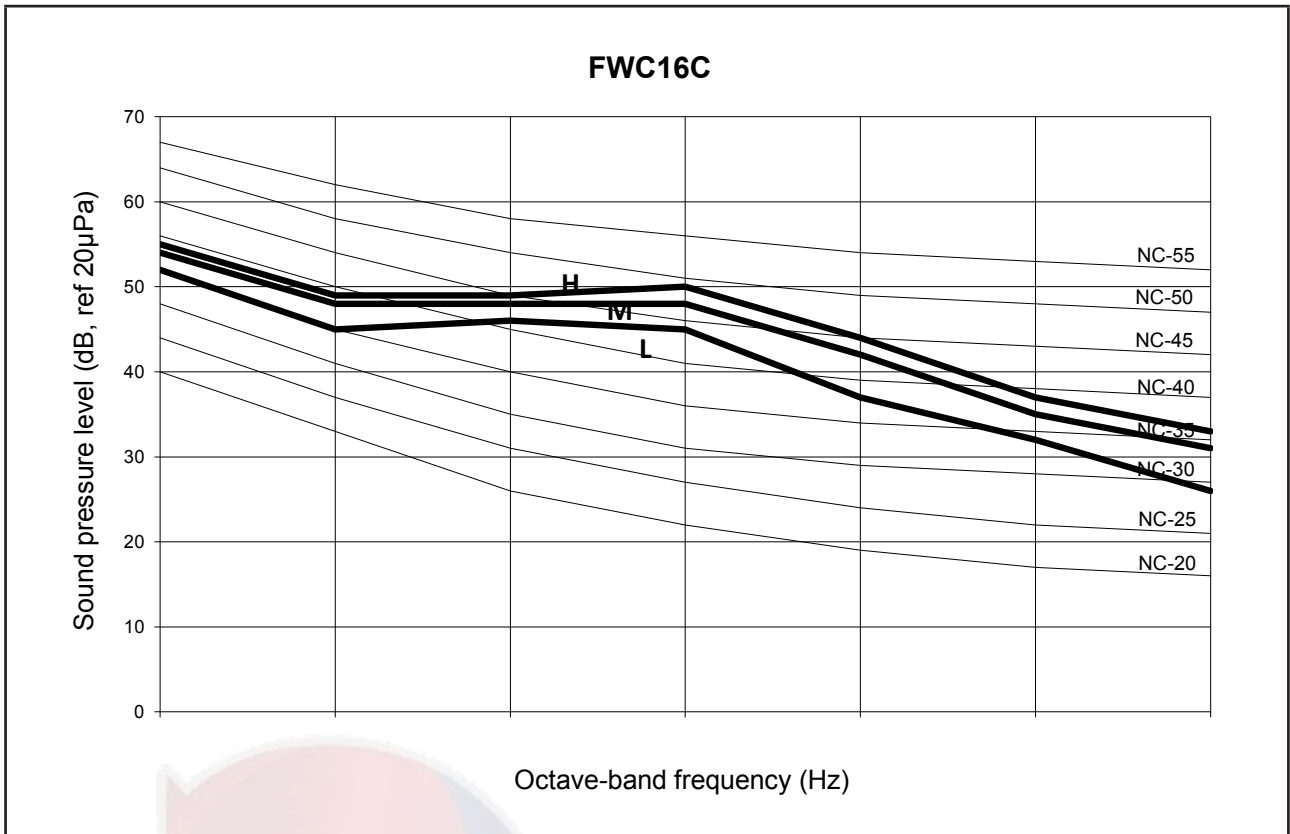

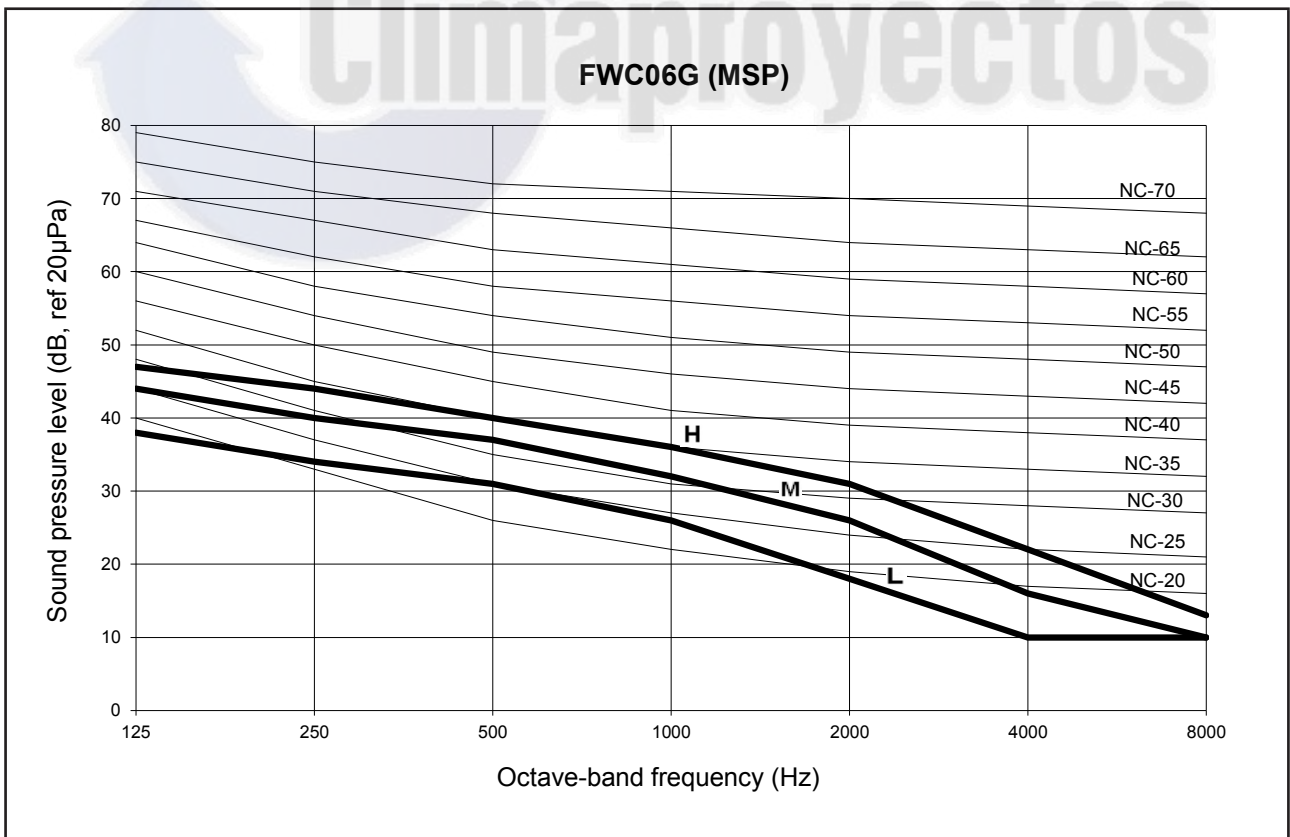
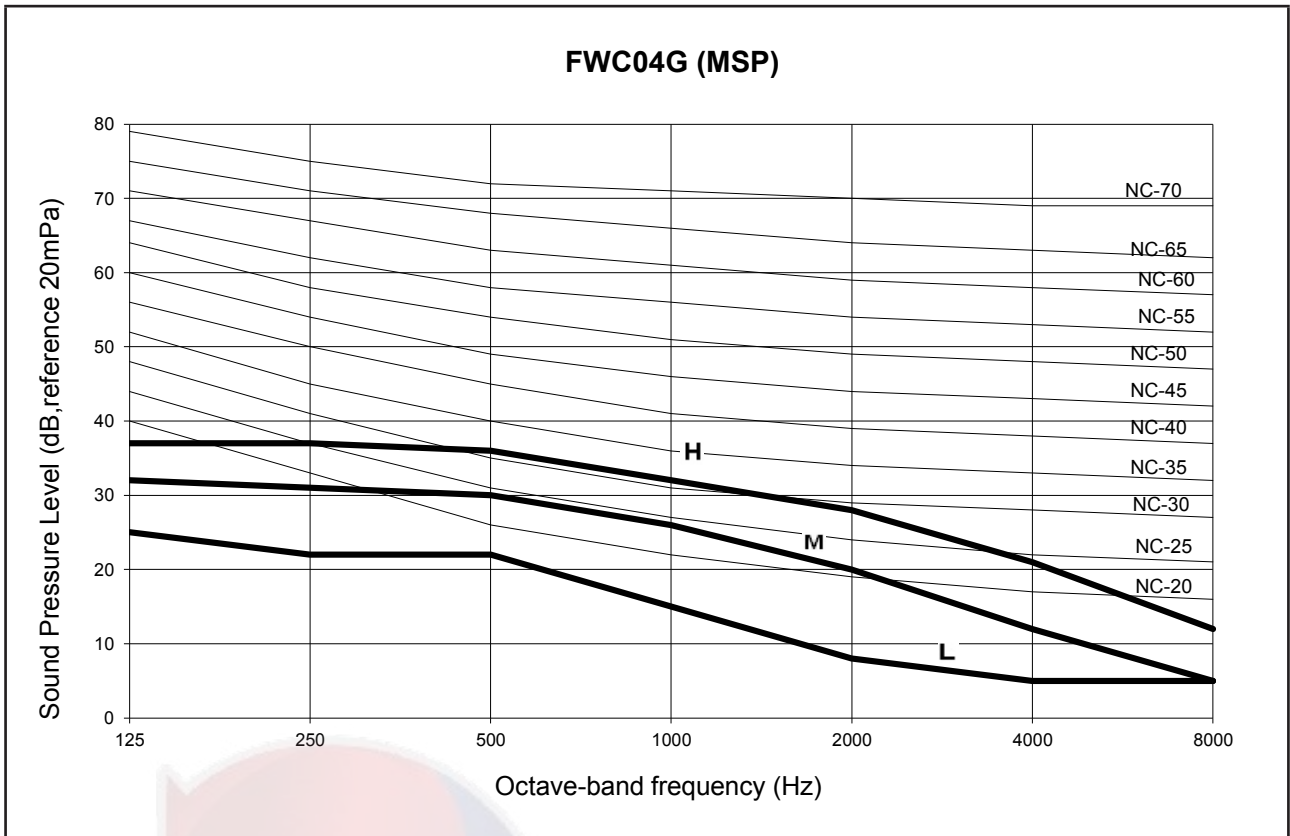

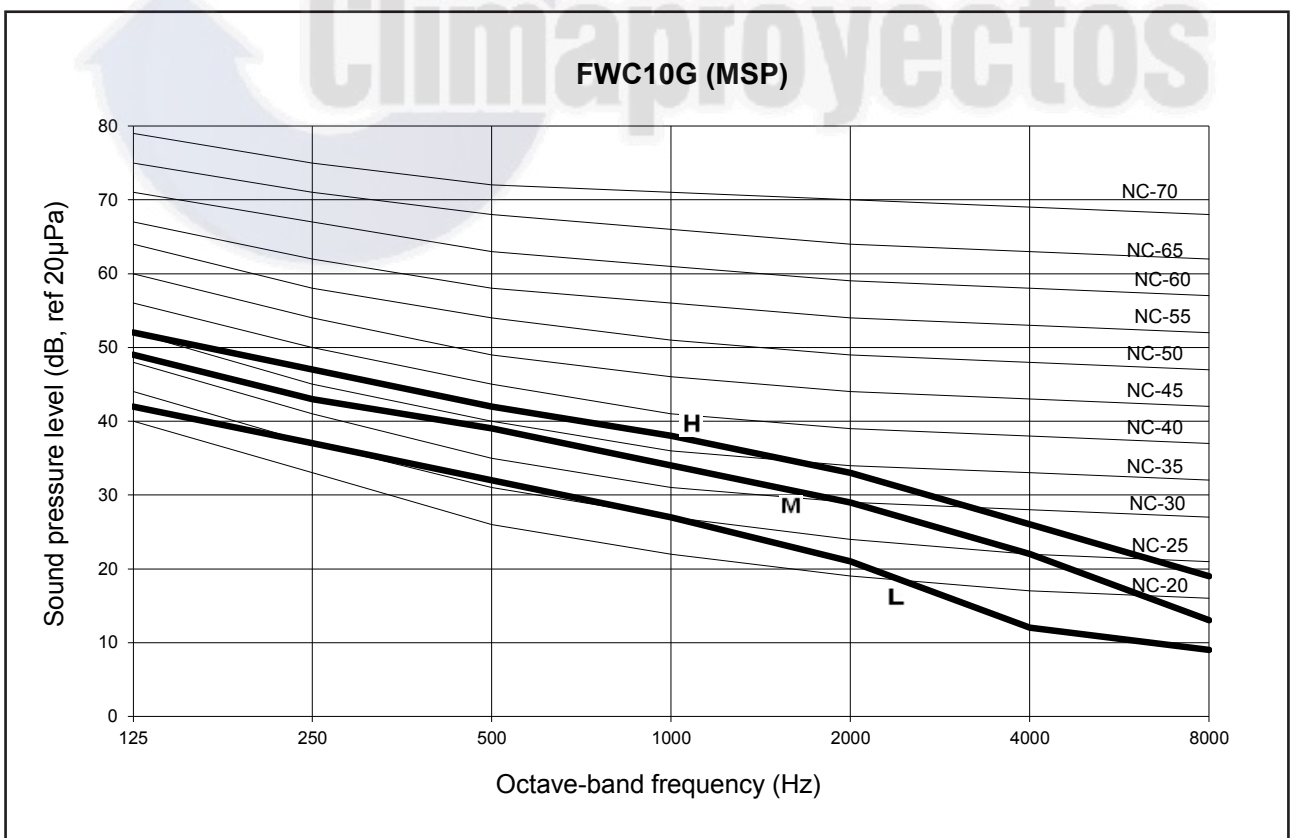
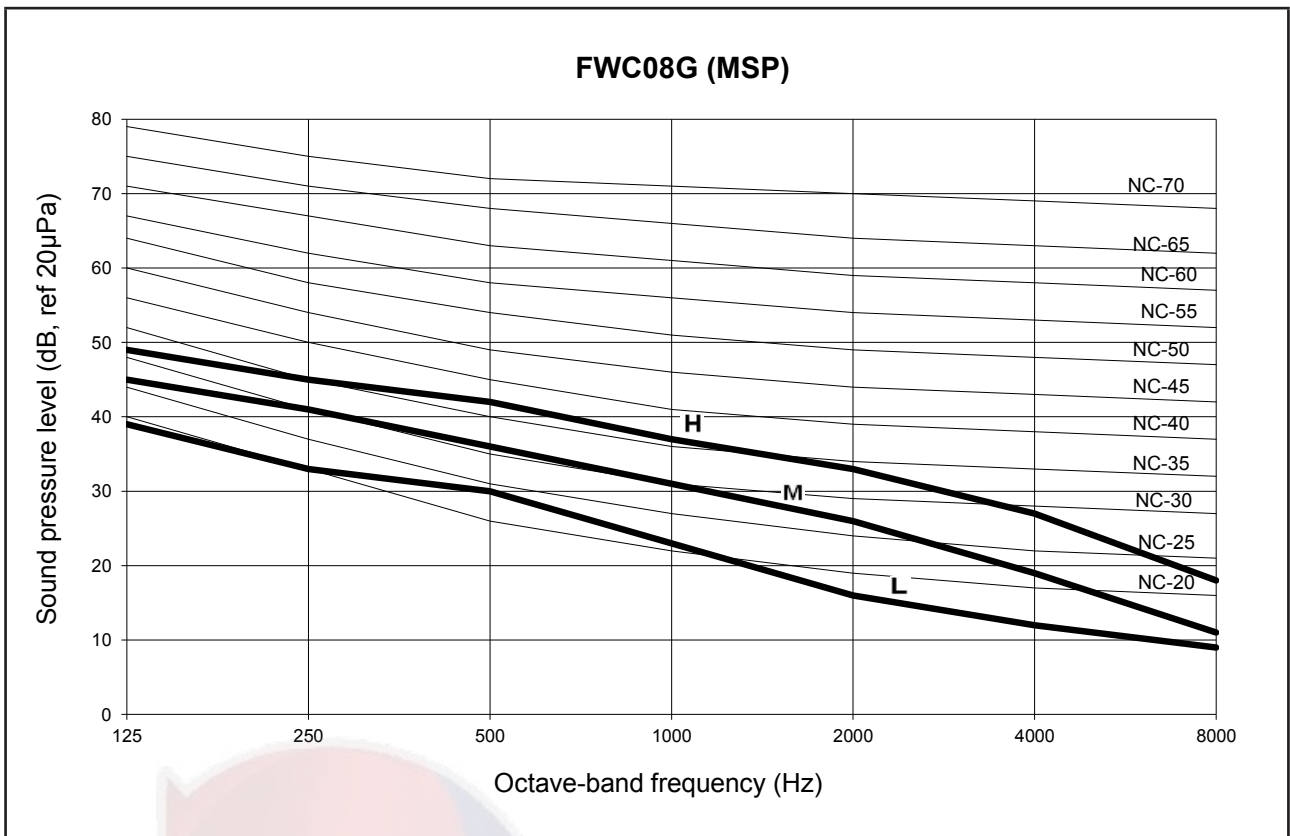

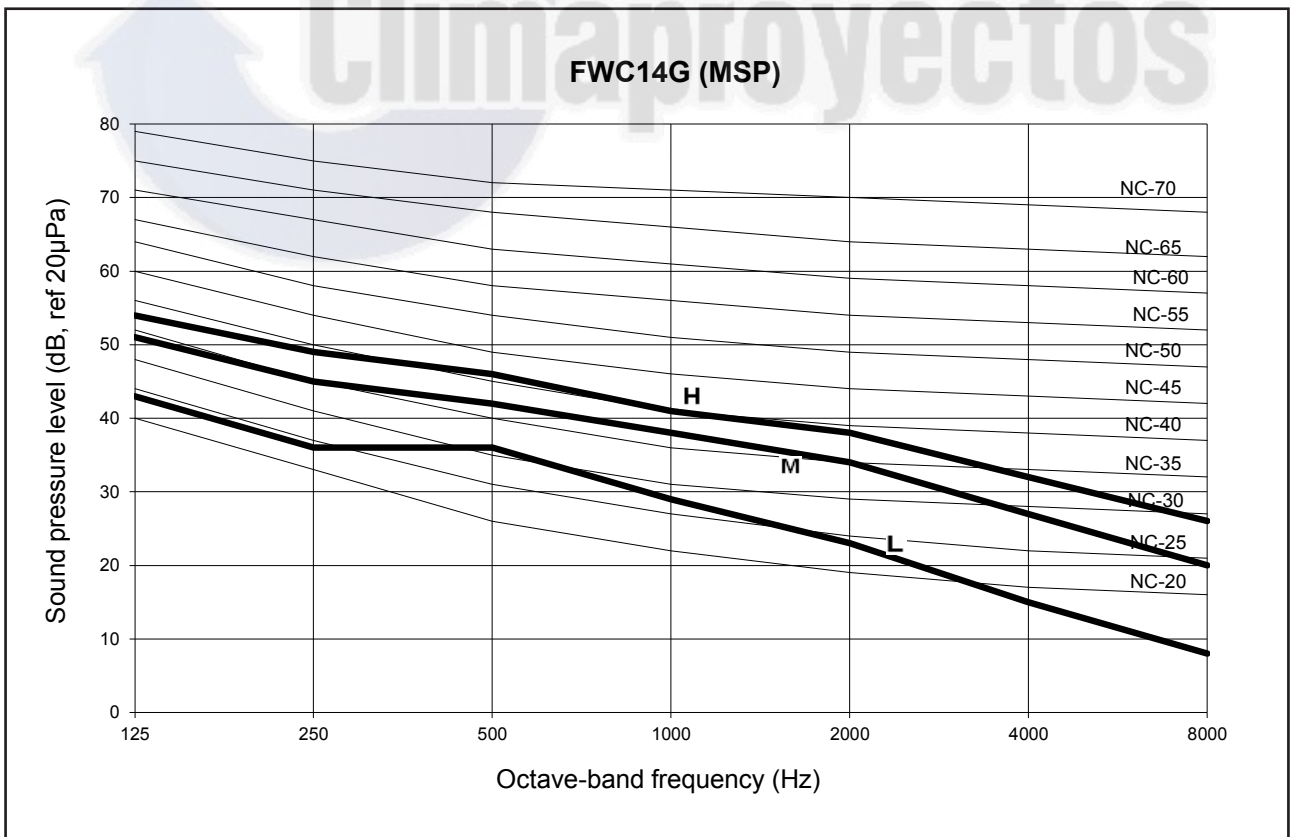
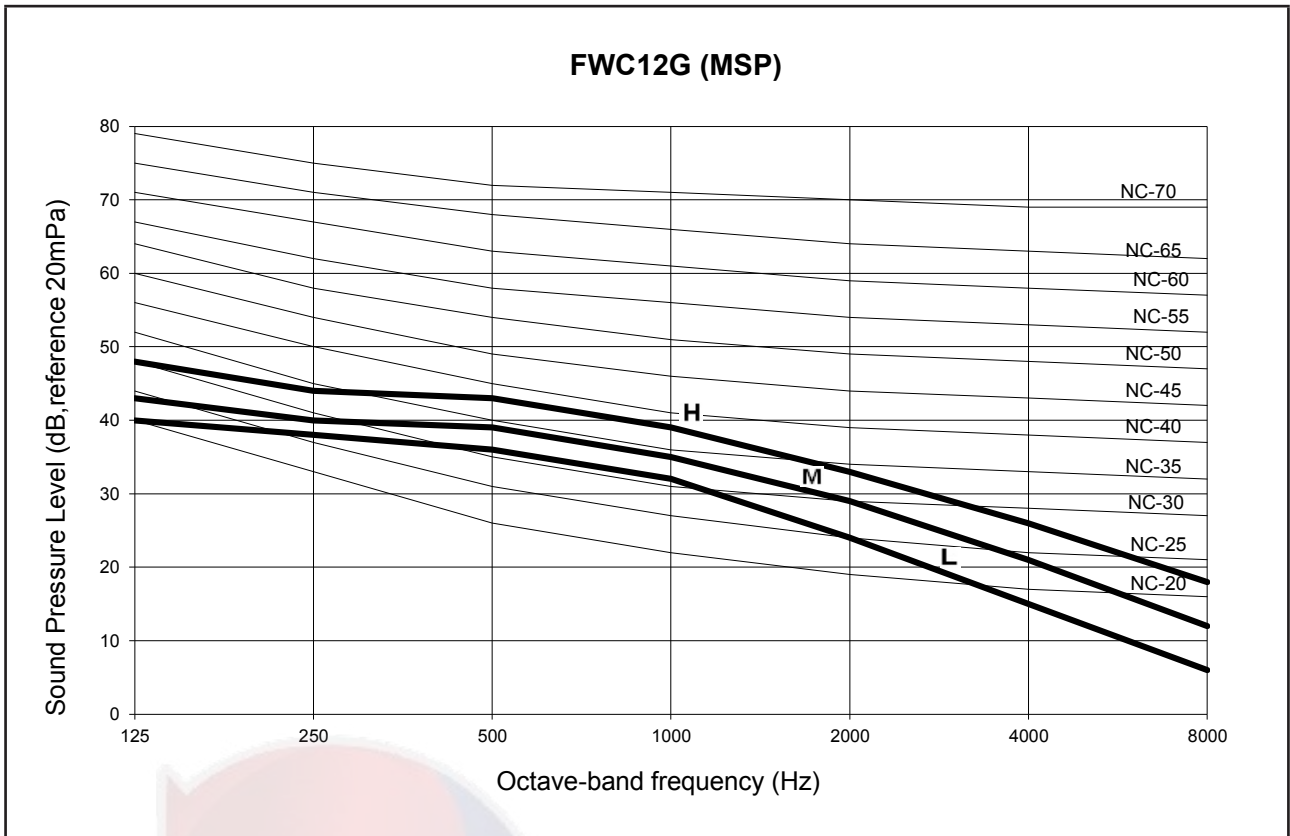

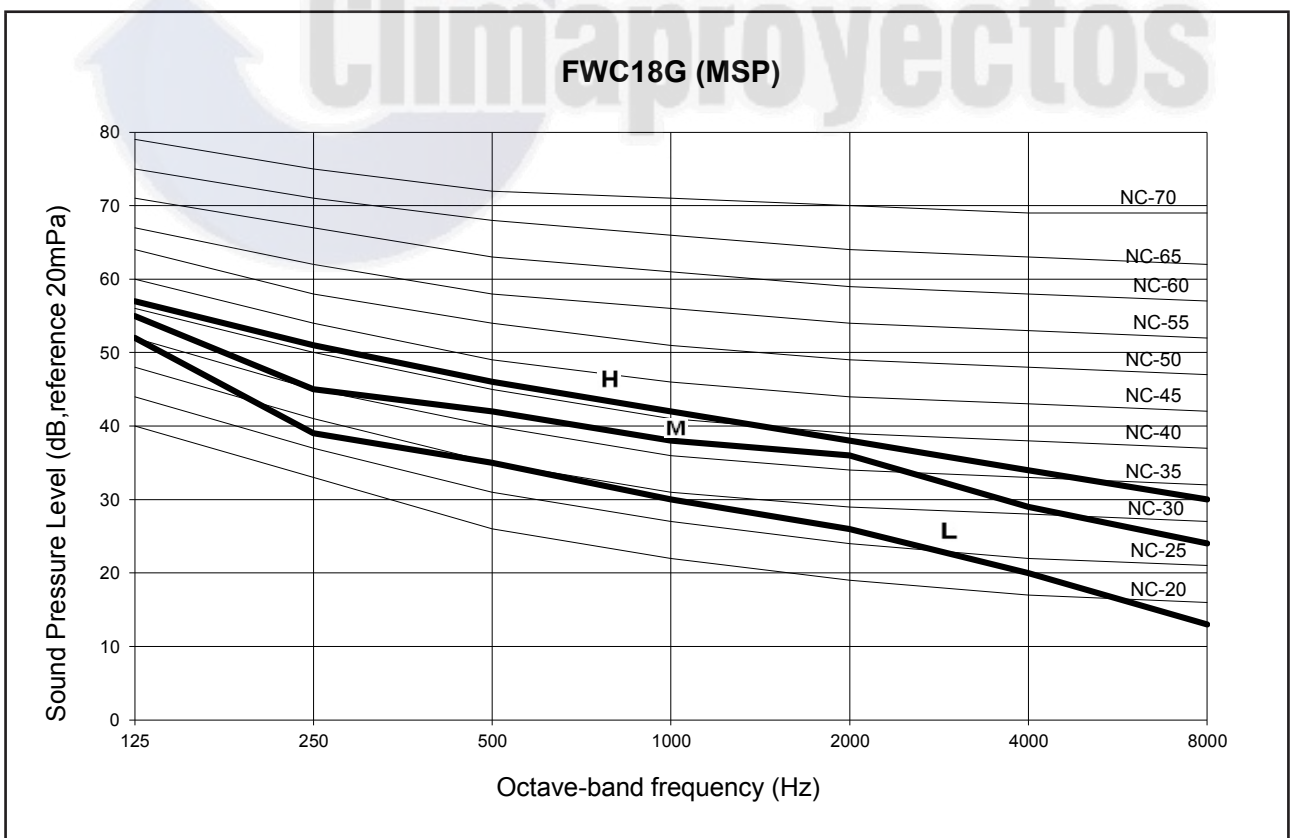
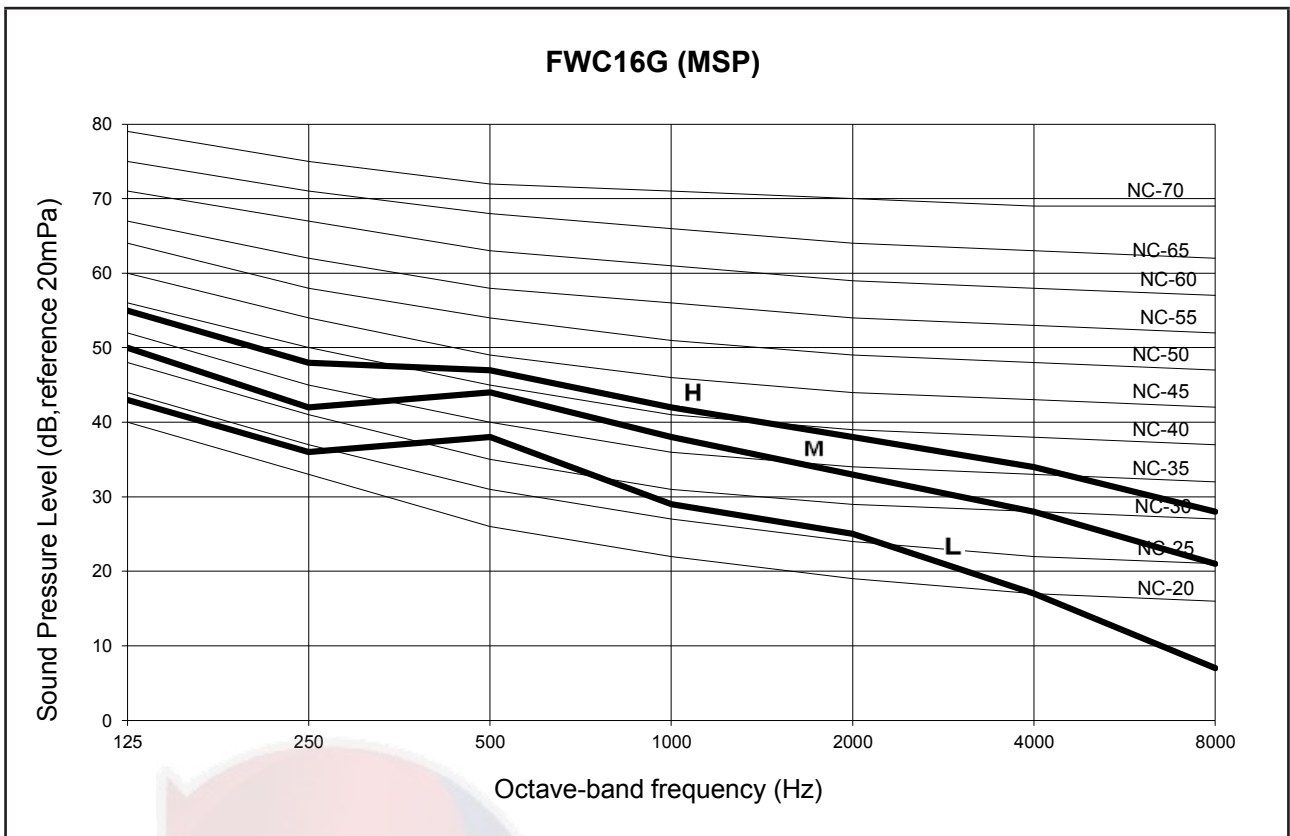

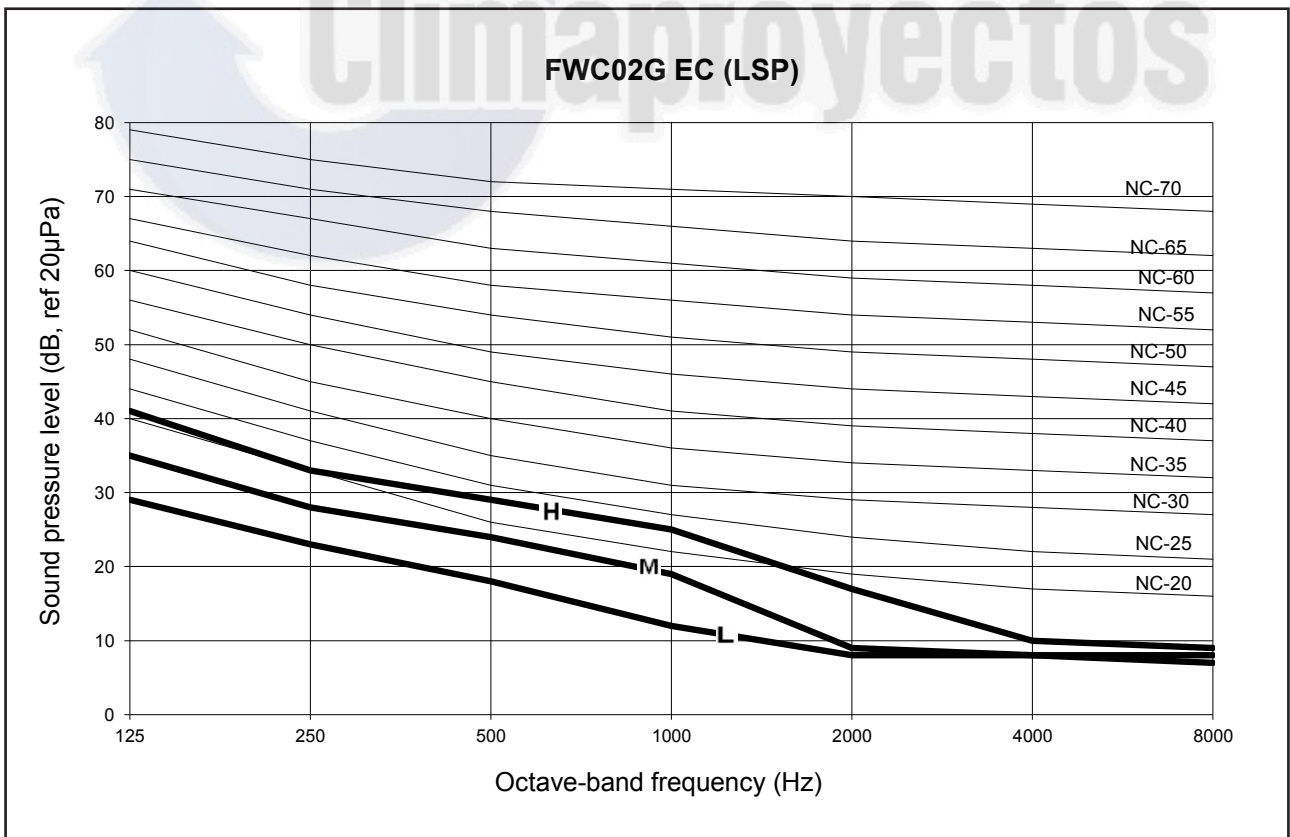
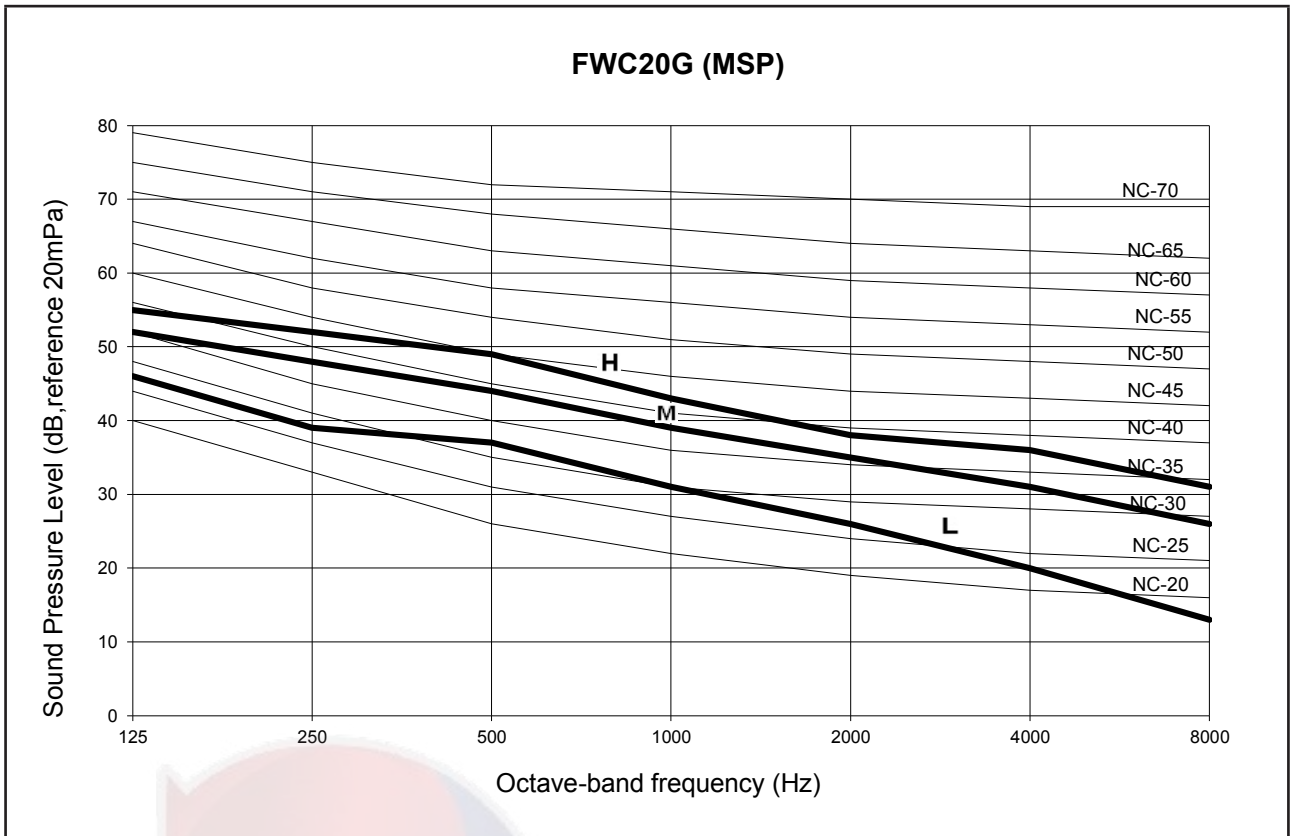

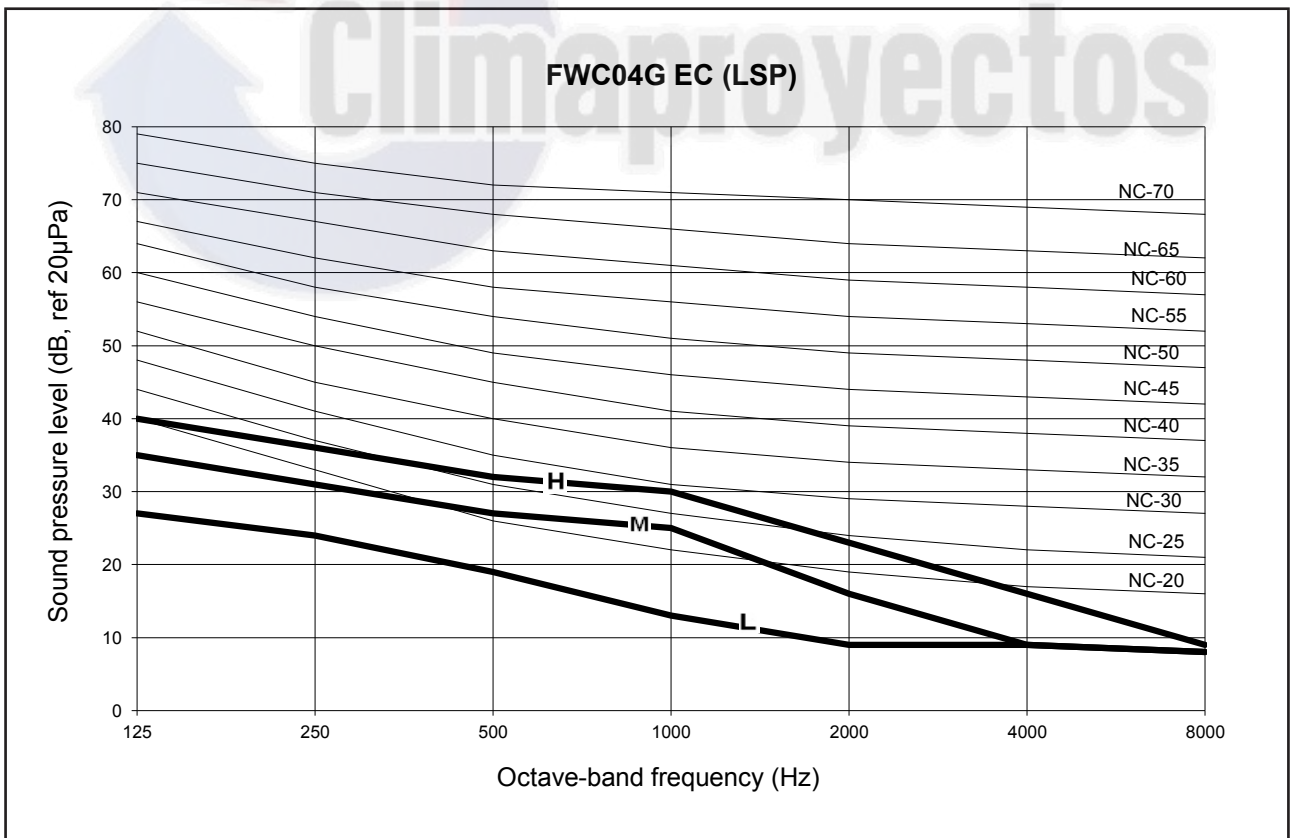
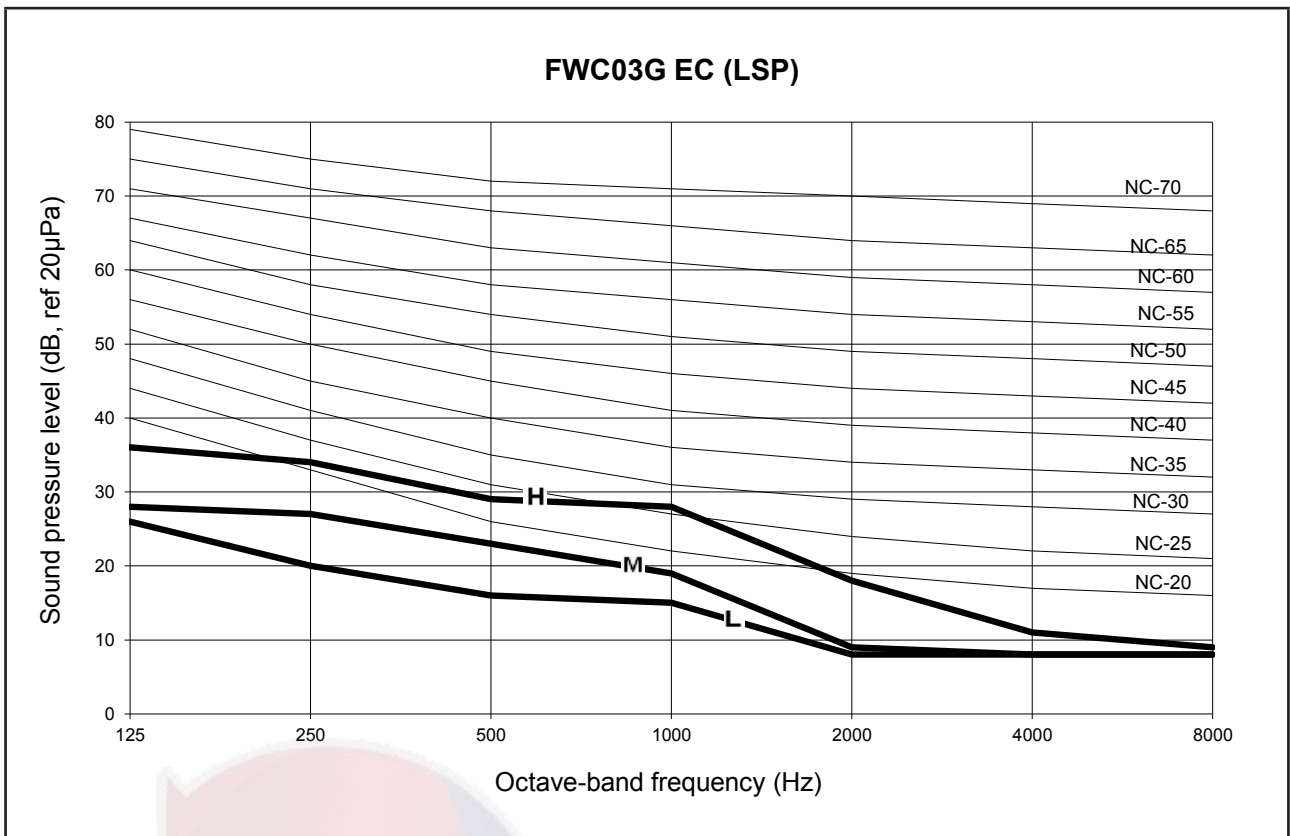



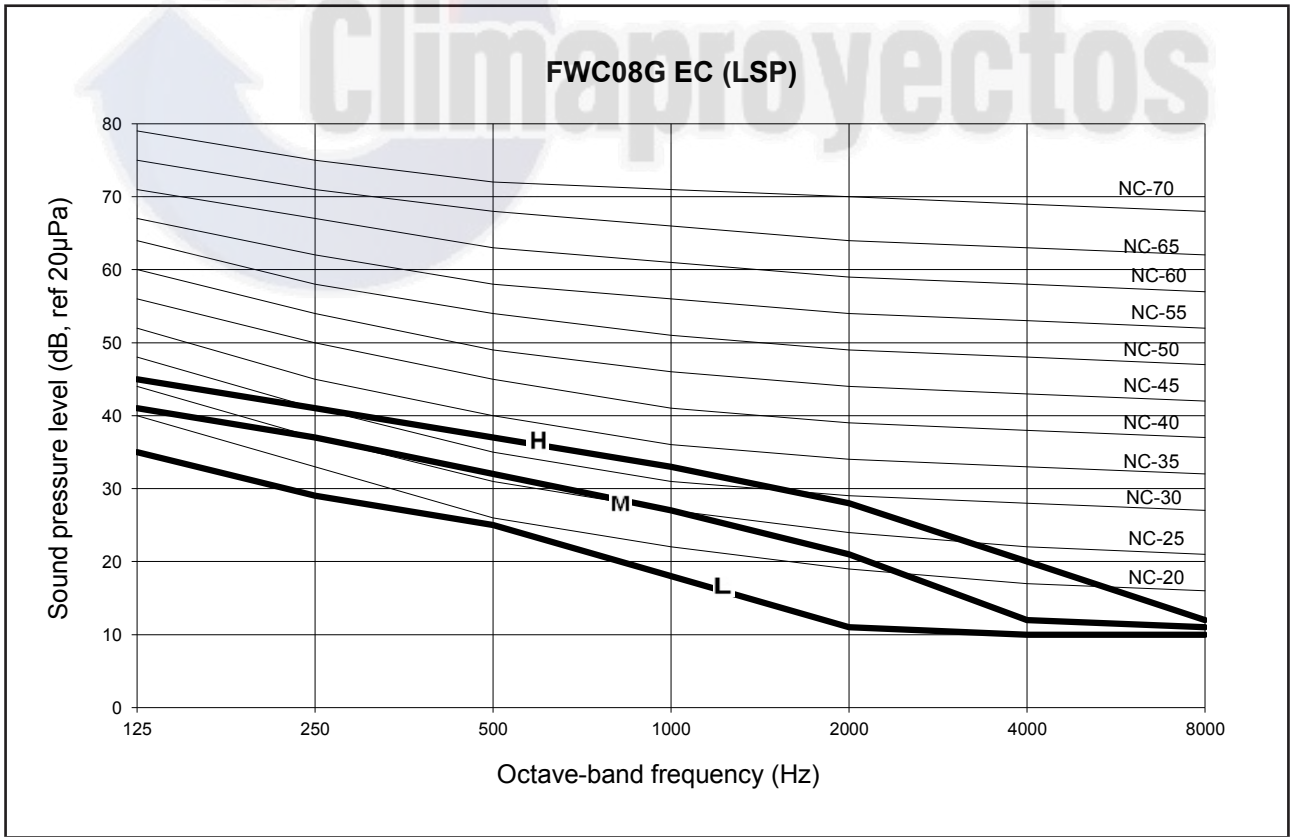
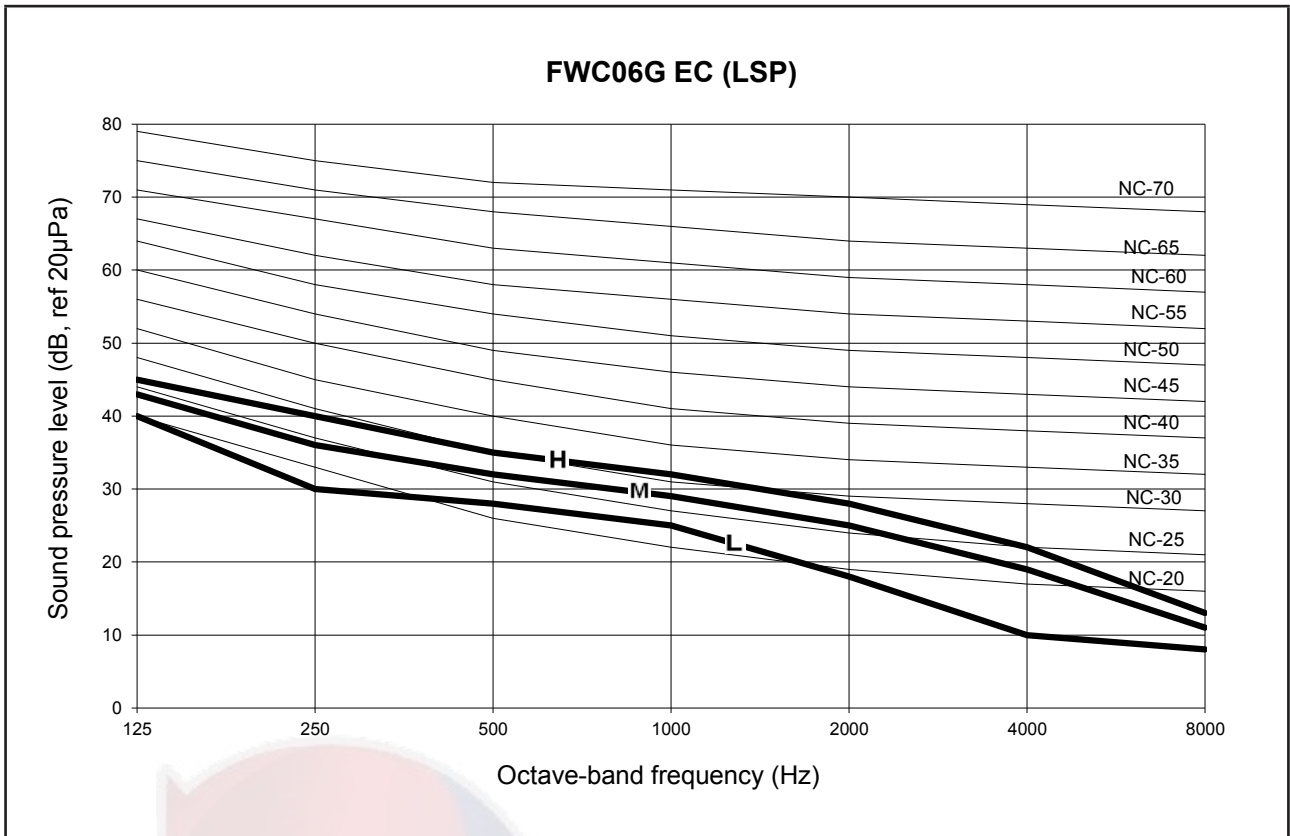

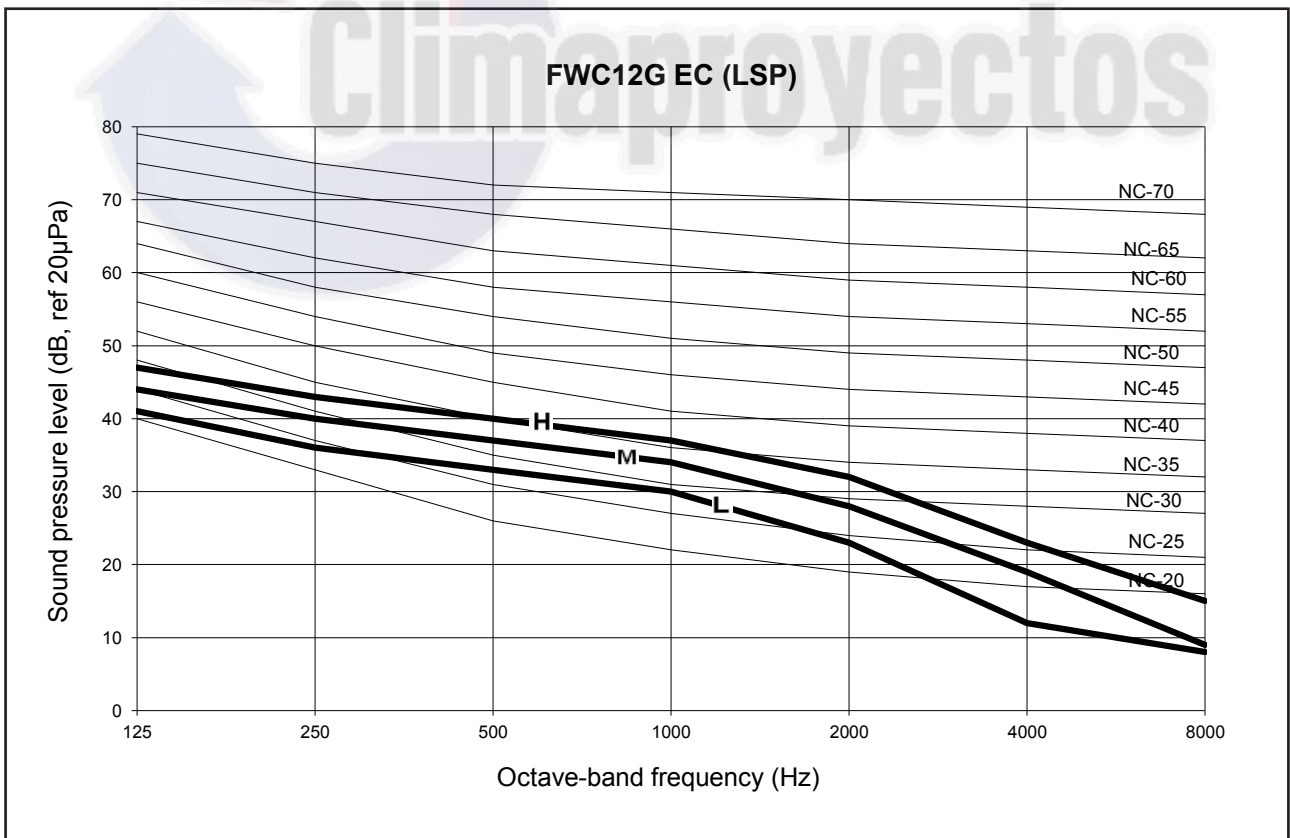
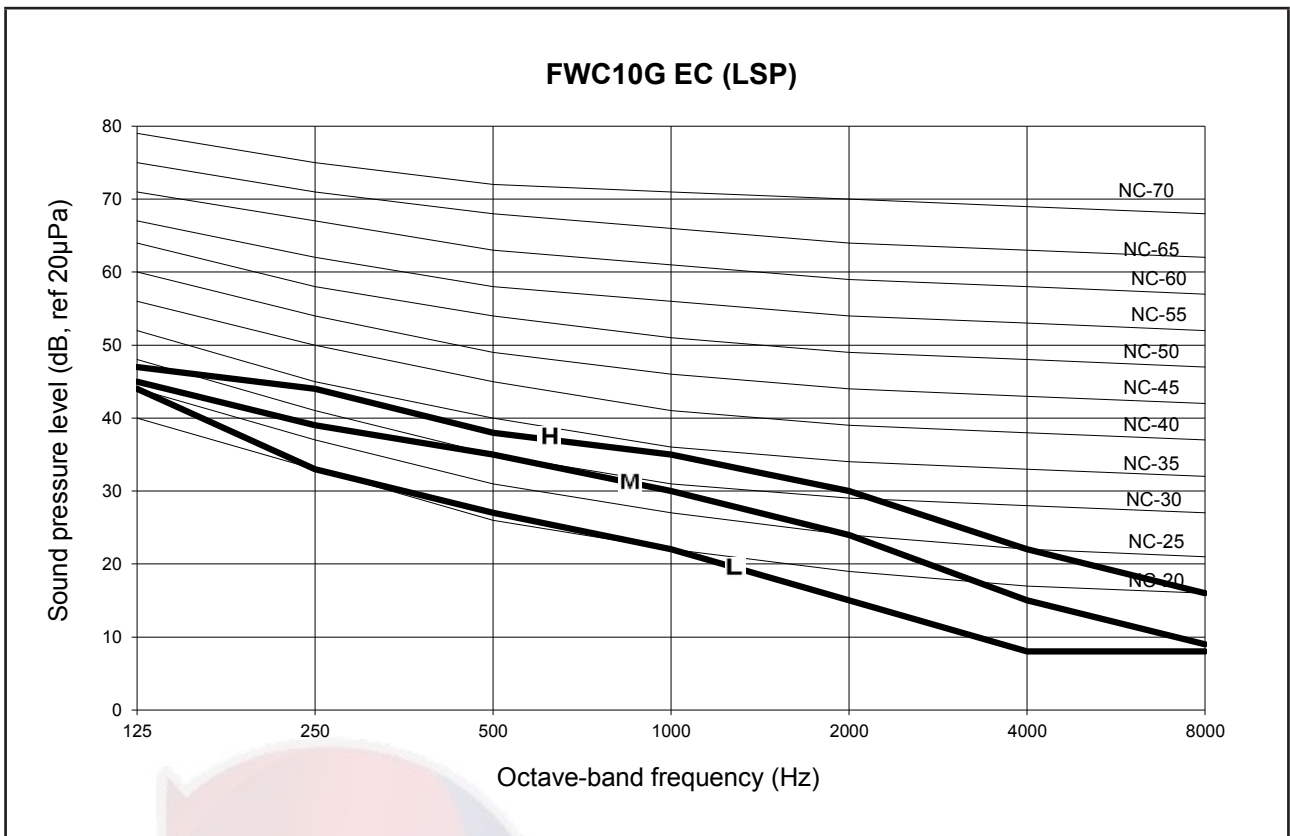

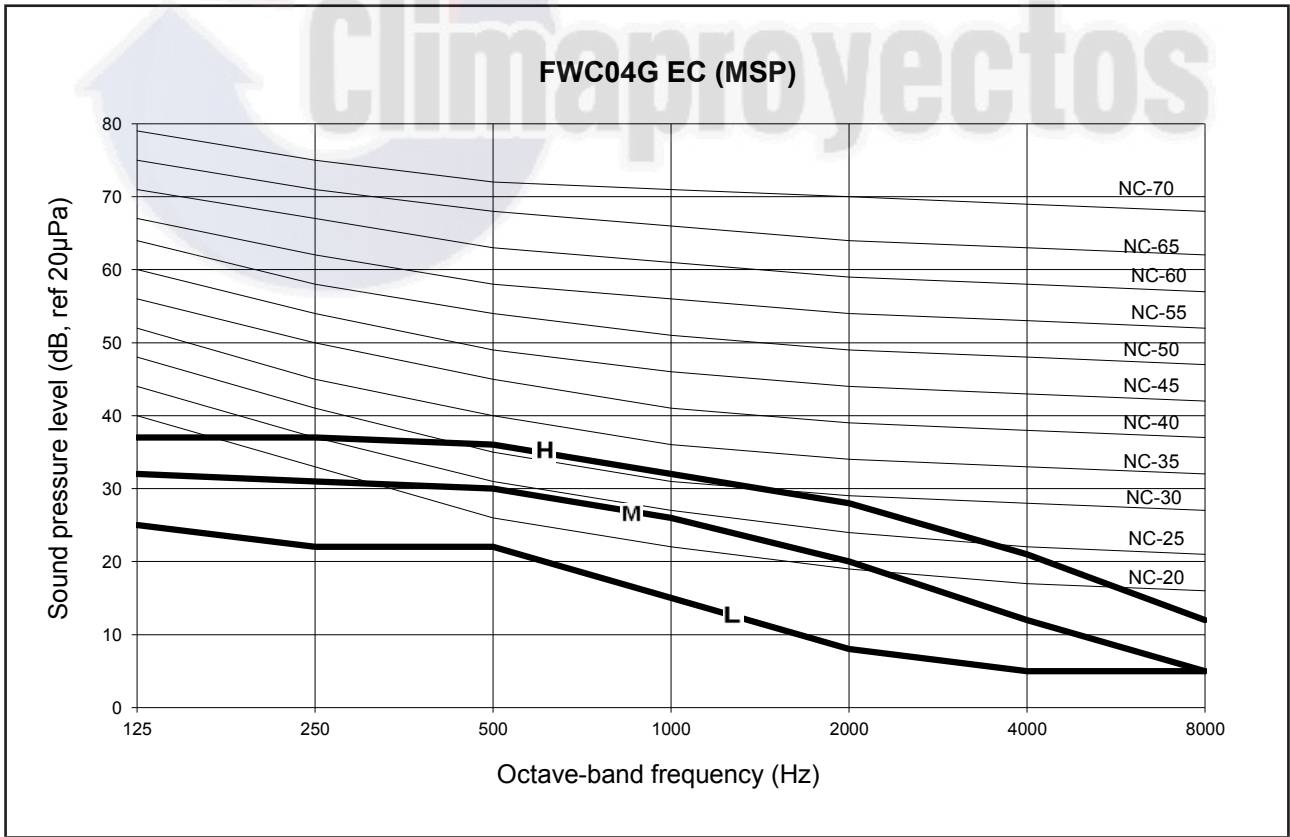
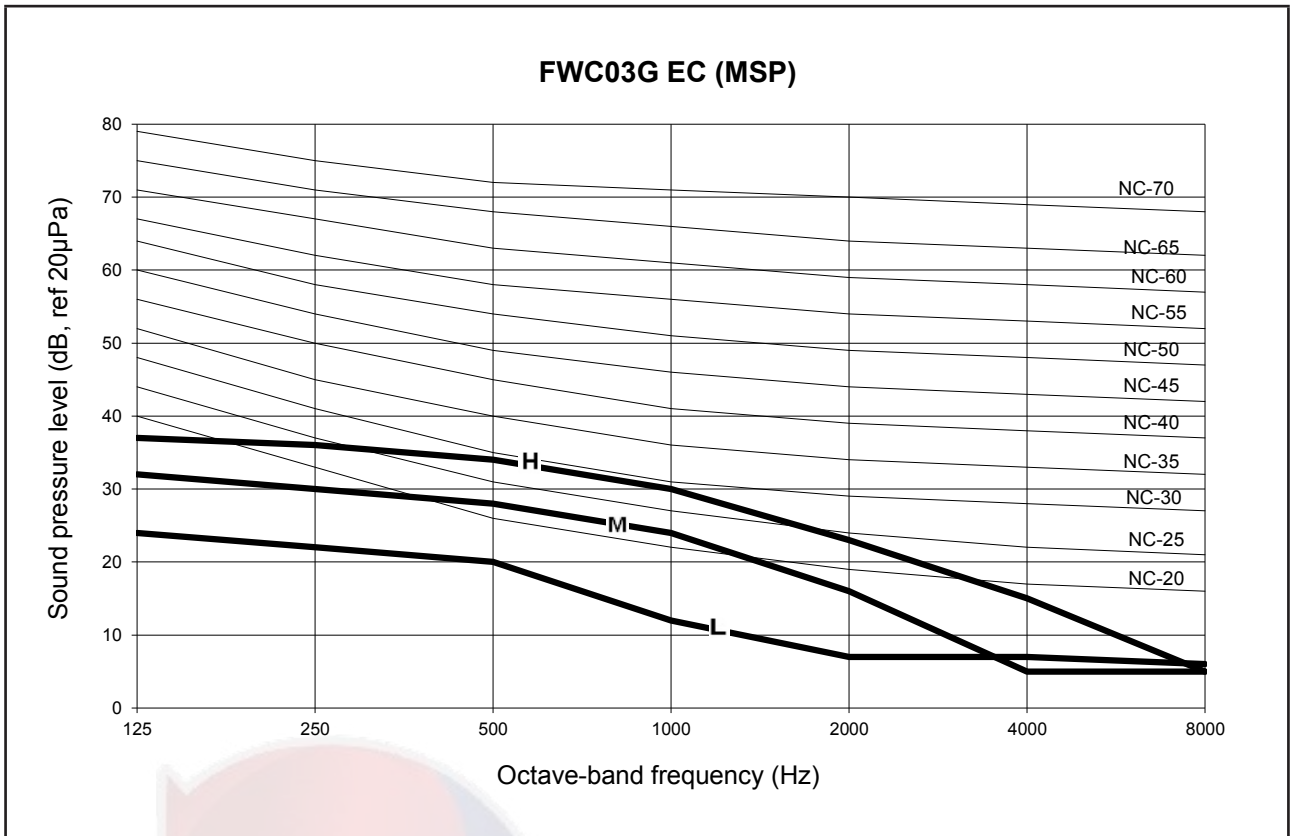

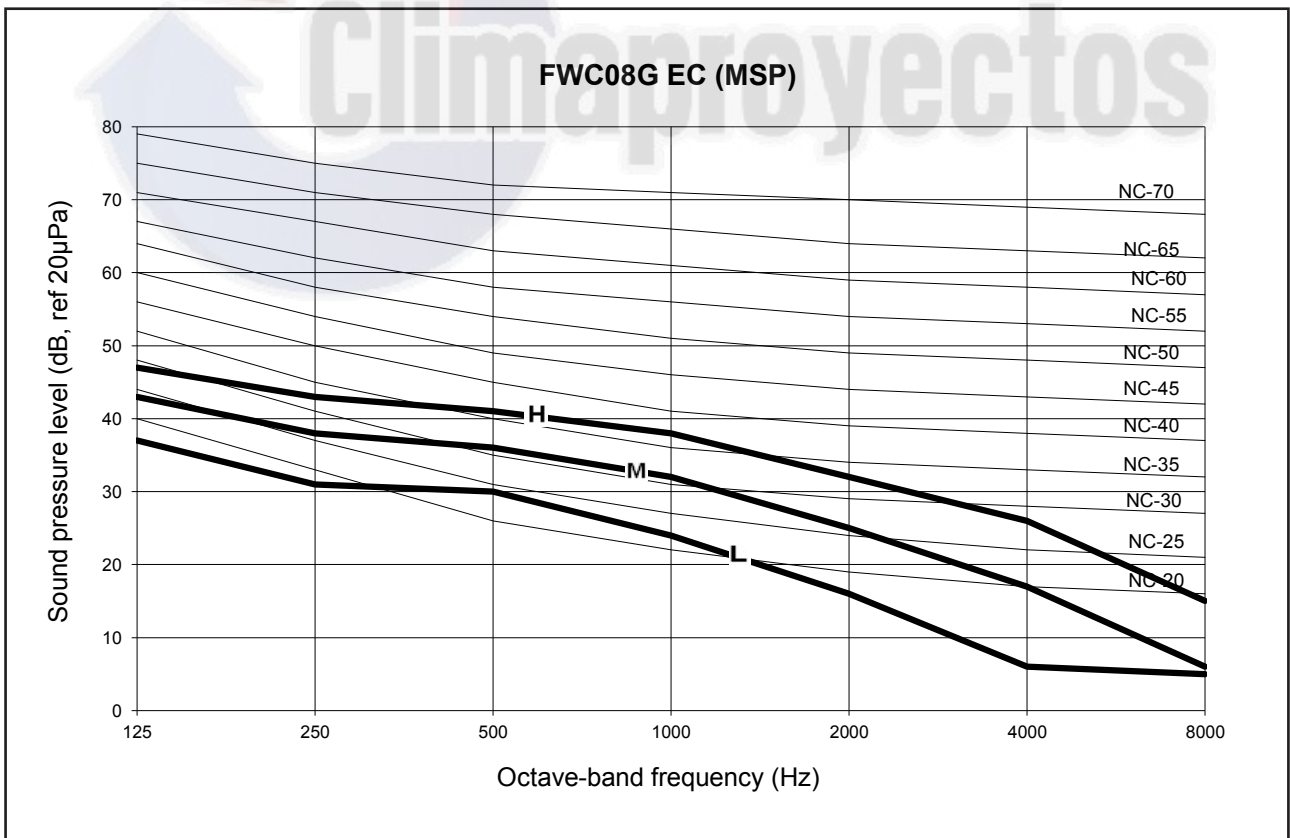
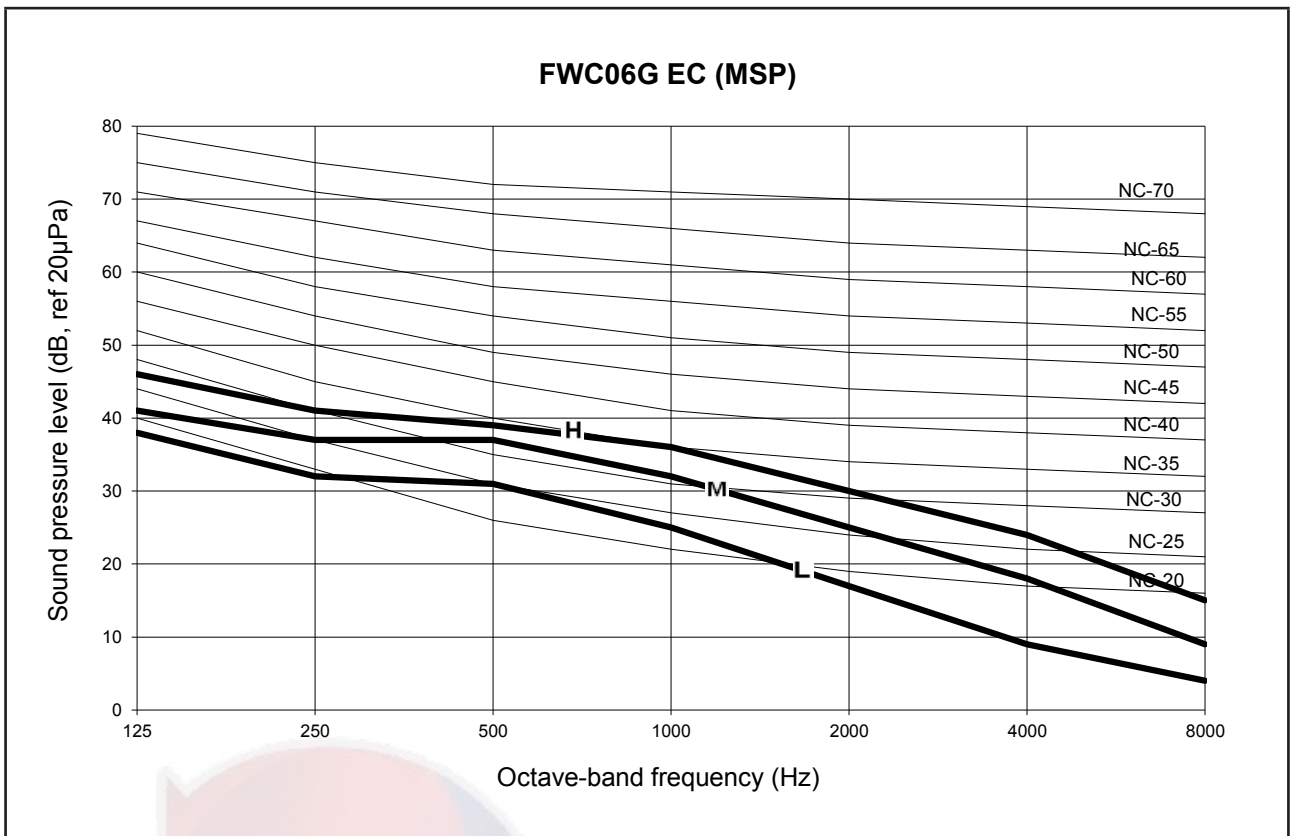

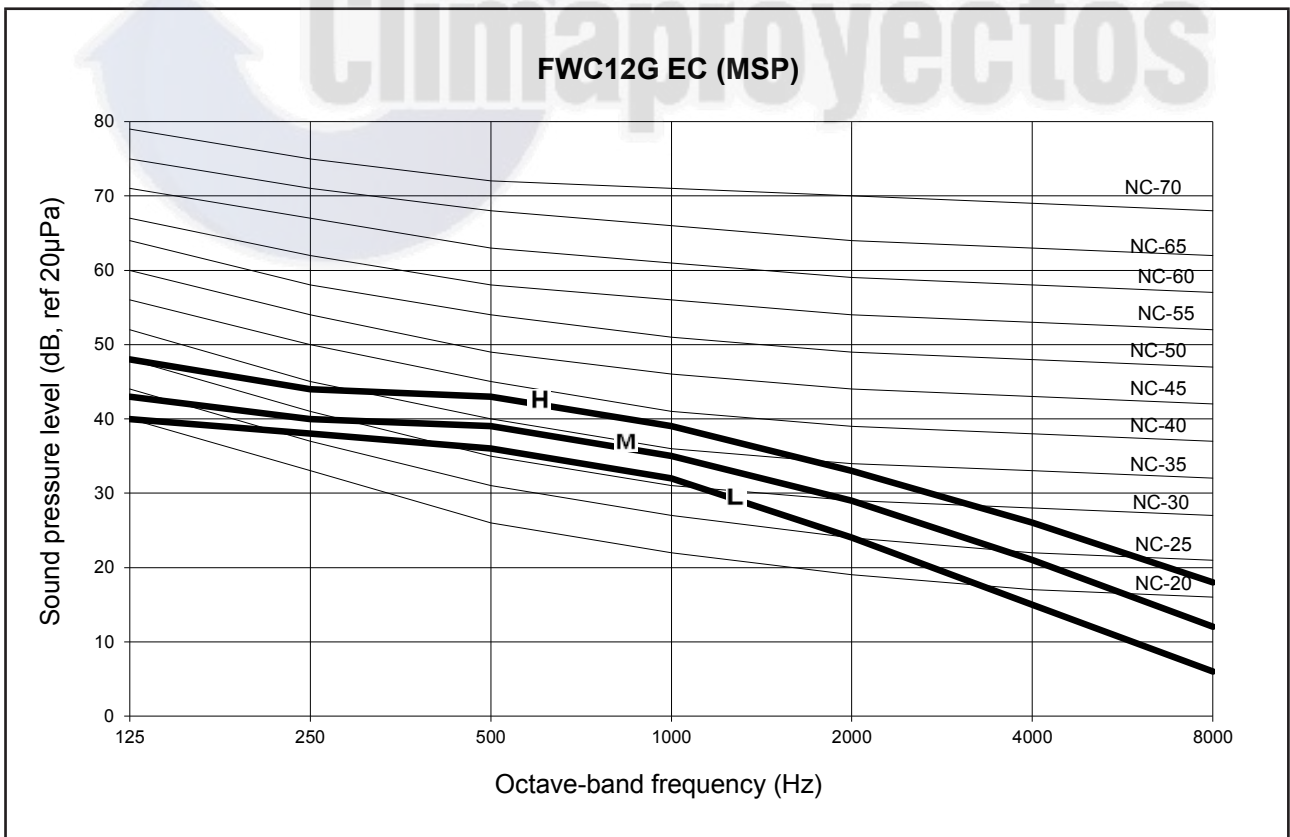
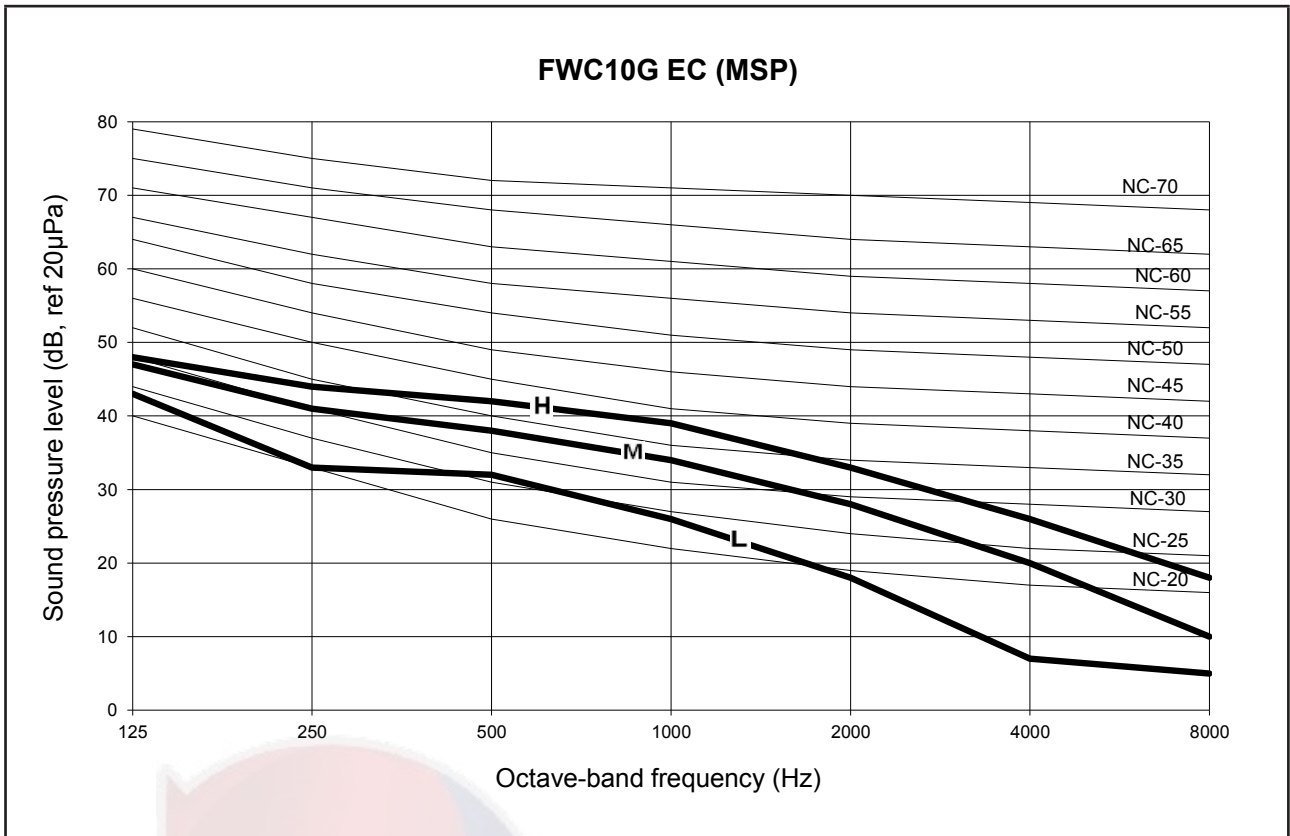

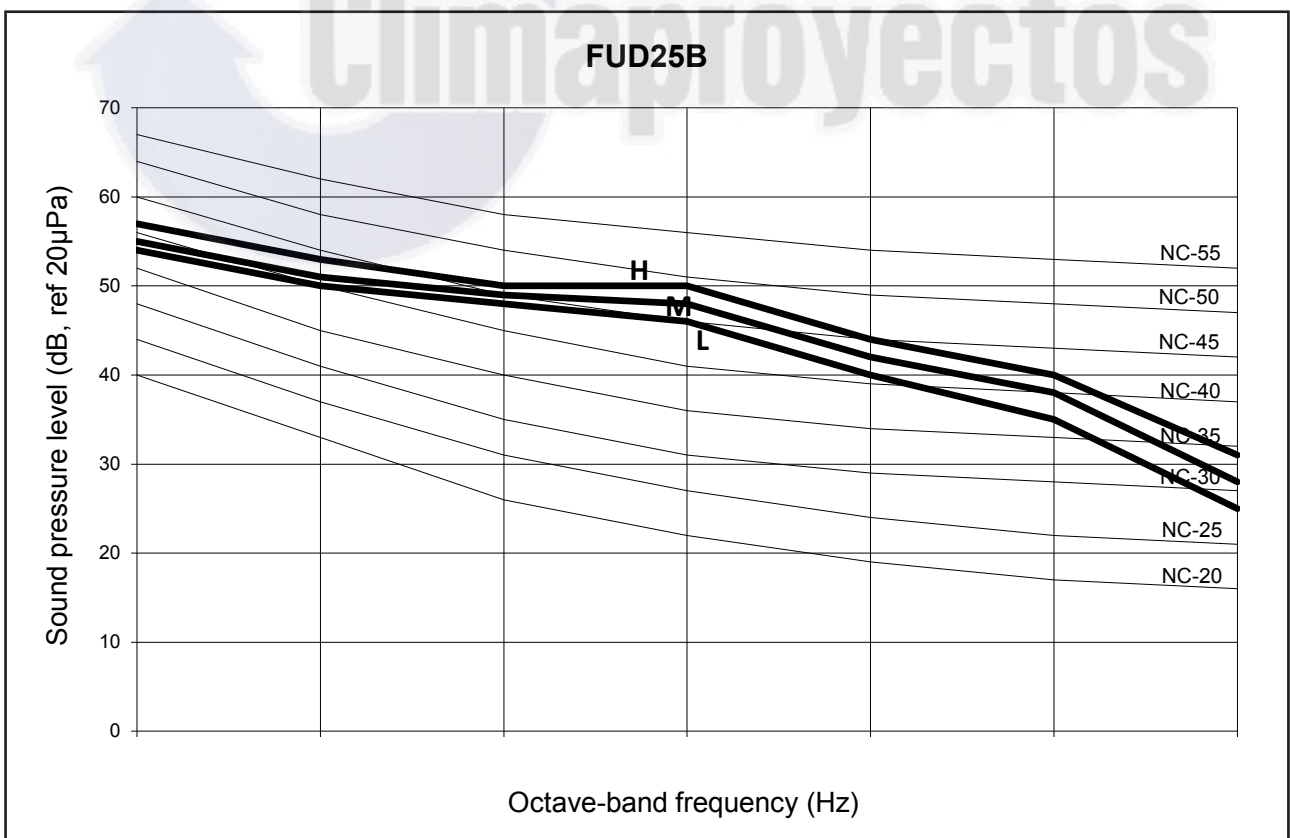
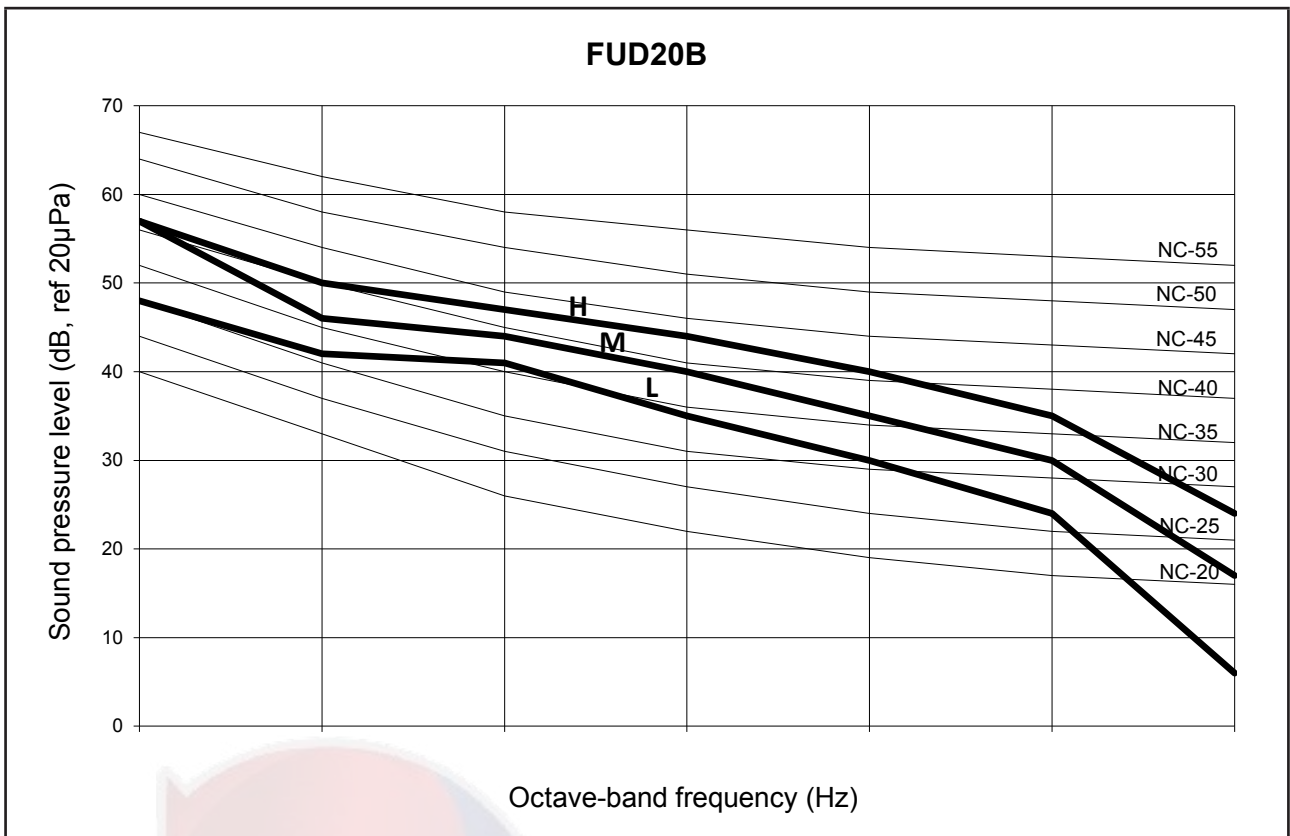

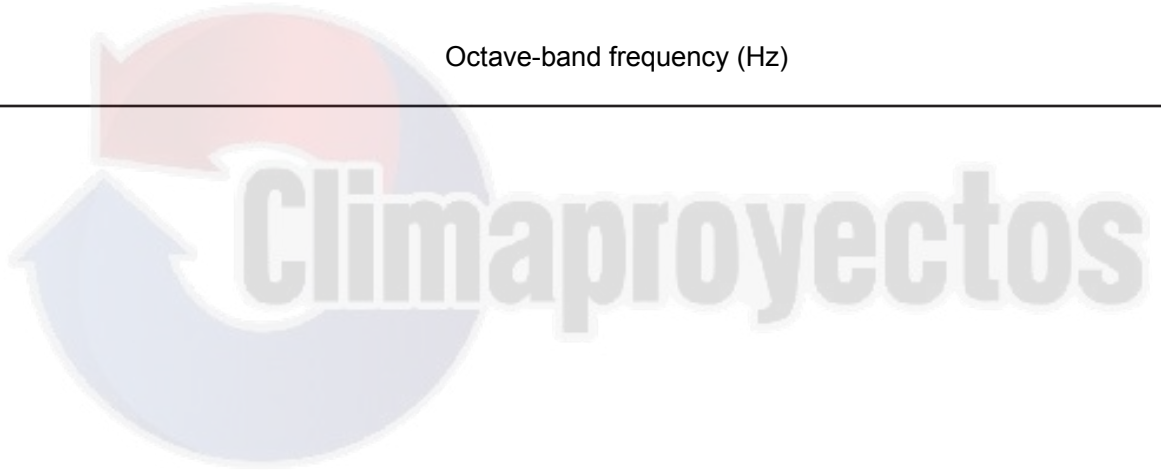
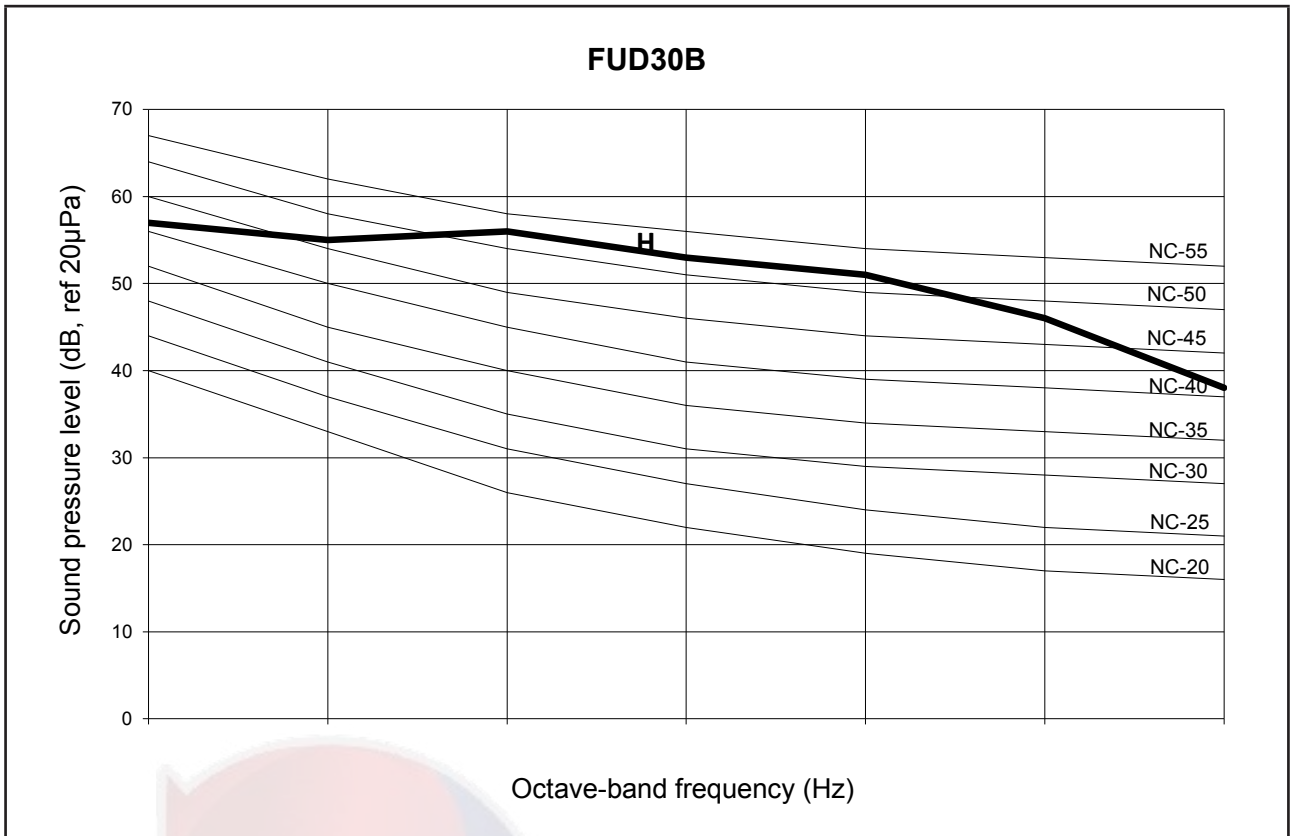

# Selection Process

## Fan Performance Chart

### Example 1 :

The following are the design requirements for FUD30B unit:			
<b>Model:</b>		<b>FUD30B</b>	
Supply Air Quantity	=	4200	CFM
External Static Pressure	=	180	Pa
Step 1:	From the fan curve (at 4200 CFM), Standard operating system;		
	Total Static Pressure	=	<b>320</b> Pa
	Internal Static Pressure	=	<b>171</b> Pa
	External Static Pressure	=	<b>149</b> Pa
	External Static Pressure of 149 Pa did not fulfill the design requirements.		
Step 2:	Therefore at 4200 CFM and 180 Pa External static pressure,		
	Total Static Pressure	=	171 + 180 Pa
		=	<b>351</b> Pa
Step 3:	From the fan curve, the design requirement calls for RPM about 800, whereas the unit can only deliver RPM about 760 under the same CFM. Therefore, it is necessary to resize the pulley sizes.		
	From the table:		
	Motor pulley	=	80 mm
	Blower pulley	=	160 mm
	Motor RPM	=	1405
	In order to obtain 800 RPM, we recalculate the new blower pulley as: (while maintaining the motor pulley)		
	Db	=	80 x (1405/800)
		=	140.5 mm
	The nearest pulley size will be a diameter of 140mm		
	Recheck, with Db = <b>140mm</b>		
	Blower pulley	=	1405 x (80/140)
		=	803
	We thus need to change the blower pulley from 160mm to 140mm in order to obtain the higher operating static pressure.		
Step 4:	When the pulley is changed, the V-belt length must be rechecked. We have for horizontal air throw configuration:		
	V-belt length, L	=	2C + 1.57 (Db + Dm)
		=	(2 x 340) + 1.57 (80 + 140)
		=	1025.4mm
	We thus can use a belt with a length of <b>1030mm</b>		
	where, C	=	distance between the centres of the two pulleys
	Db	=	diameter of blower pulley
	Dm	=	diameter of motor pulley
Step 5:	From the fan curve, we can also notice that the motor power input has increased. At the new operating point, the power is approximately 1.25 kW.		
	By applying a safety factor of 1.2 to account for losses, we calculate that the motor power input requirement should be = 1.25 x 1.2 = <b>1.5 kW</b>		
	Thus, the existing motor is still sufficient to drive the blower with the smaller 140mm pulley.		
	<b>Summary:</b>		
	i) Fan motor kW	=	<b>1.5</b> kW
	ii) Blower pulley diameter	=	<b>140</b> mm
	iii) V-belt size	=	<b>1030</b> mm



The following table summarizes the pulley data, motor size used for the FUD series, as manufactured:

Model	Motor Size	Motor Speed	Motor Pulley Diameter	Blower Pulley Diameter	Pulley Center Distance, C		V-Belt Length	V-Belt Length
	kW	RPM			mm	mm	Horizontal	Vertical
			mm	mm	mm	mm	mm	mm
FUD30B	1.5	1405	80	160	340	350	1060	1080
FUD40B	1.5	1405	80	160	340	350	1060	1080

Example 1:

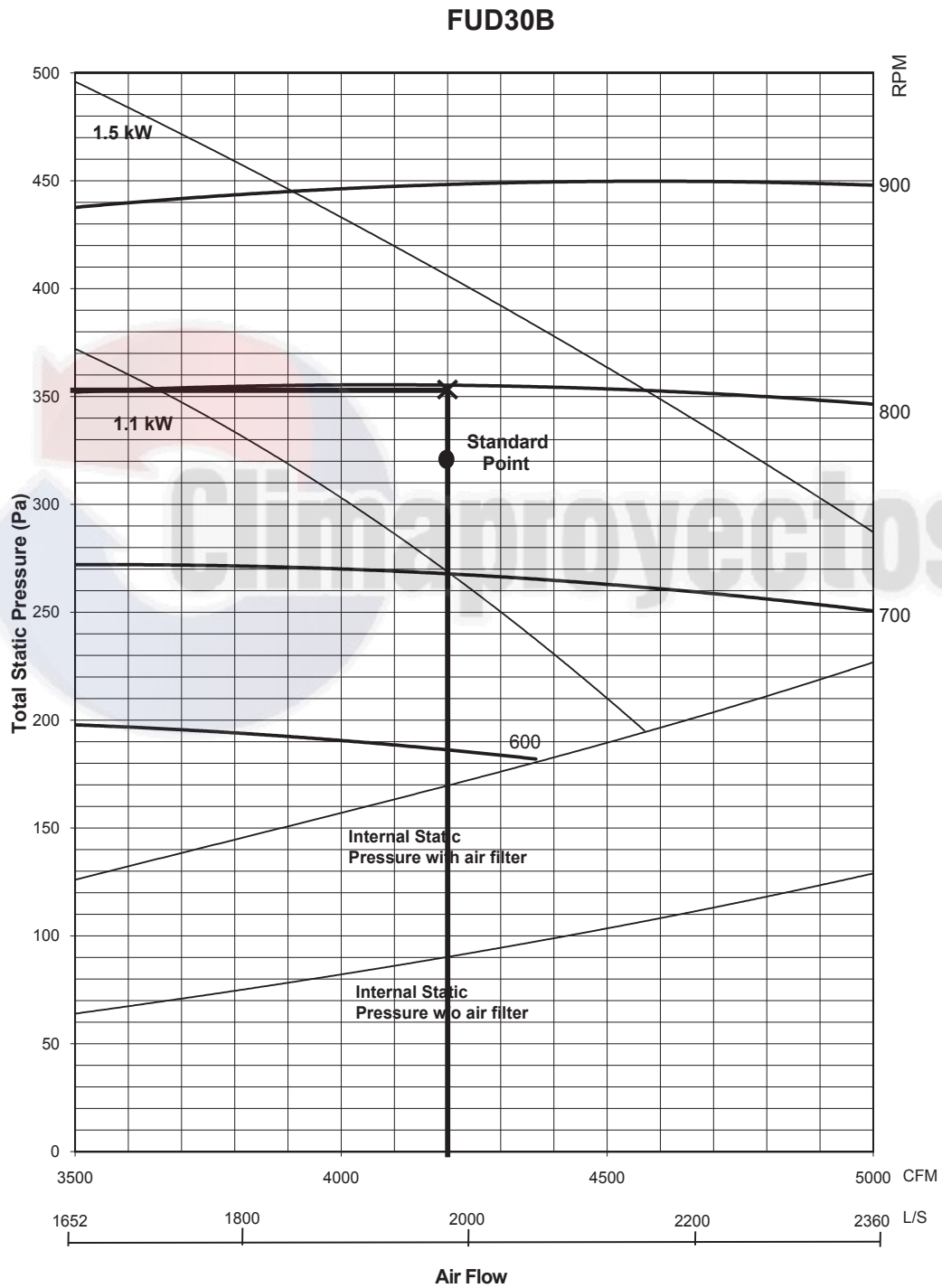

# Fan Performance Chart

Fan Performance Curve

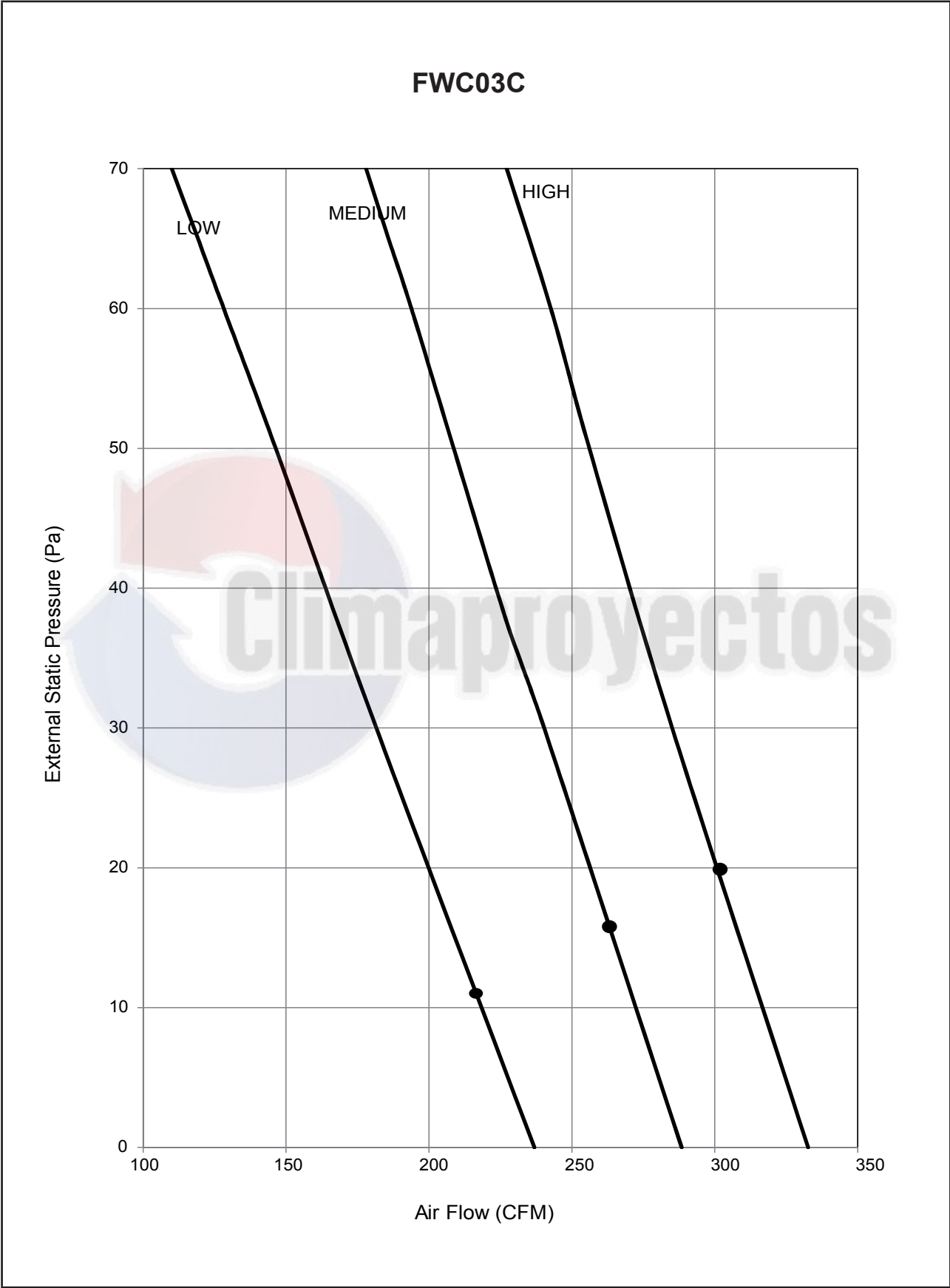

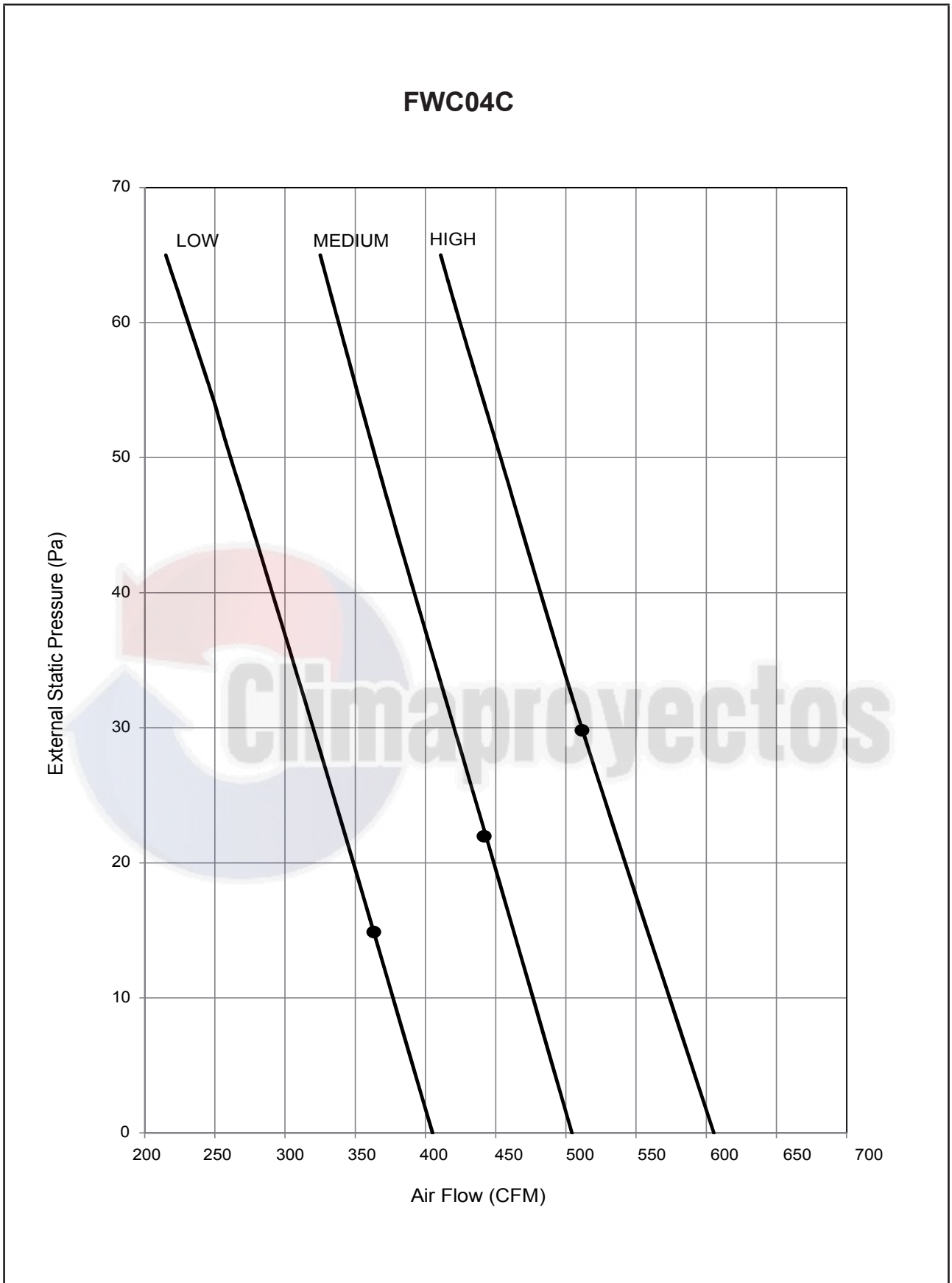

### FWC06C

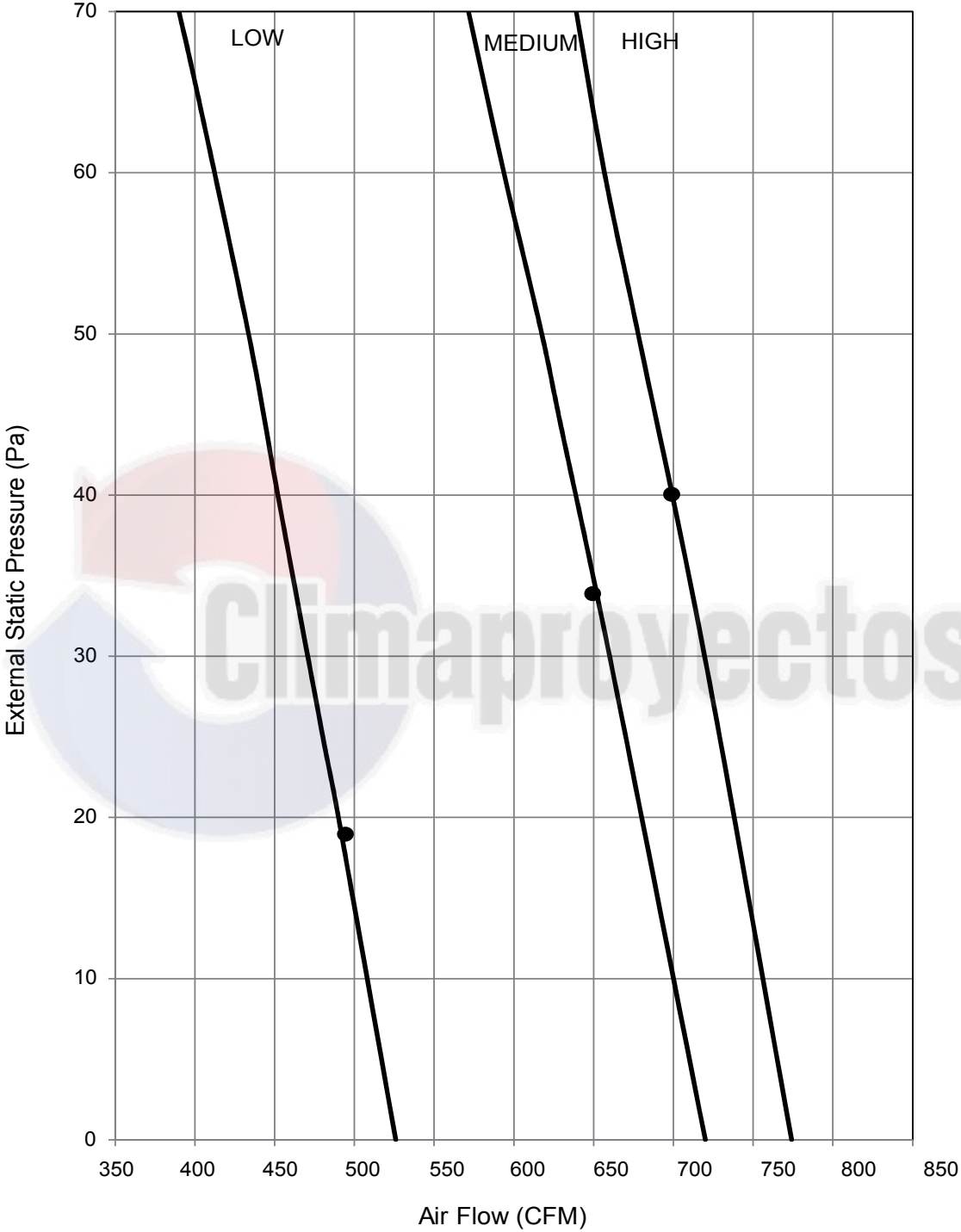

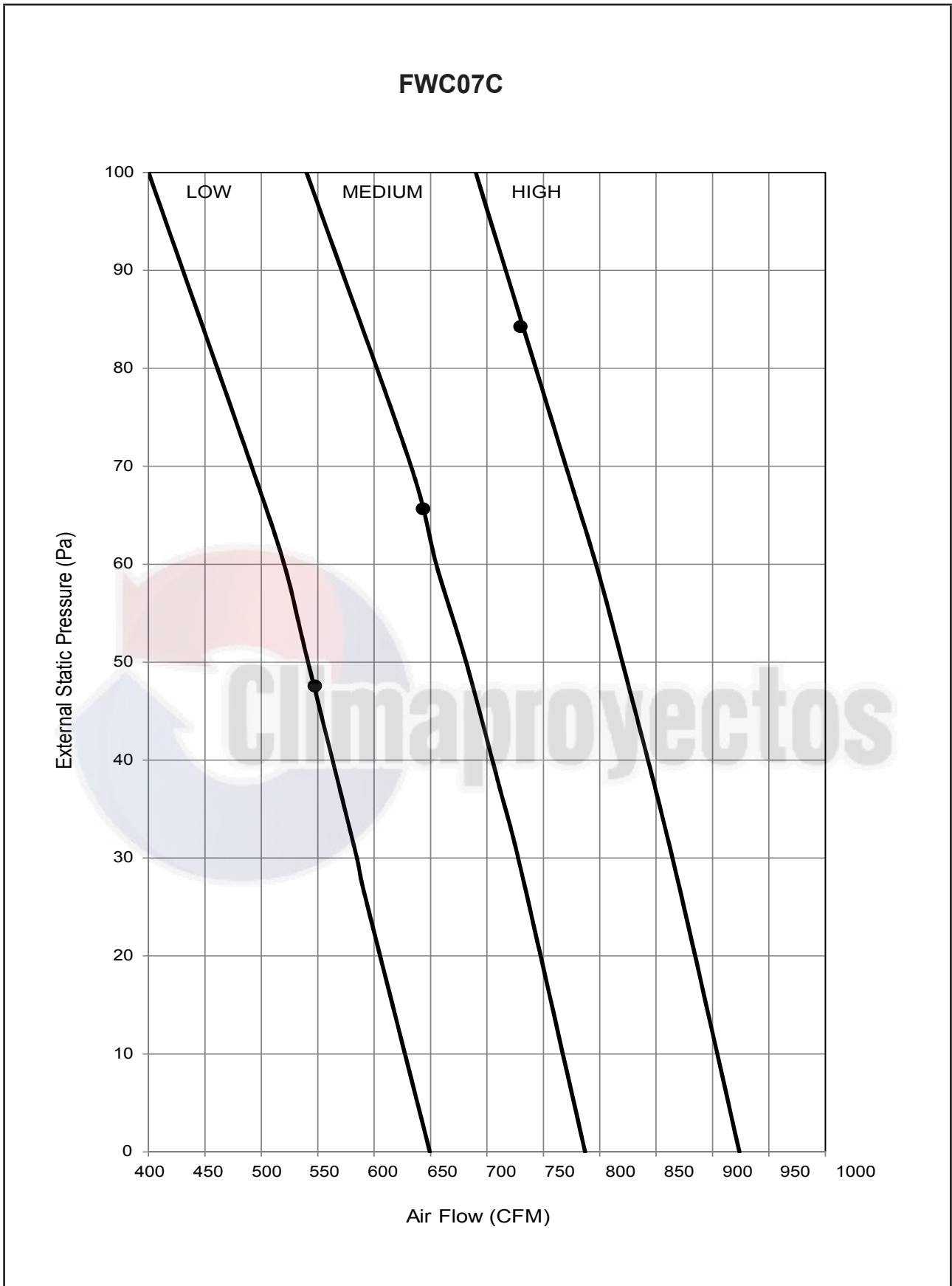

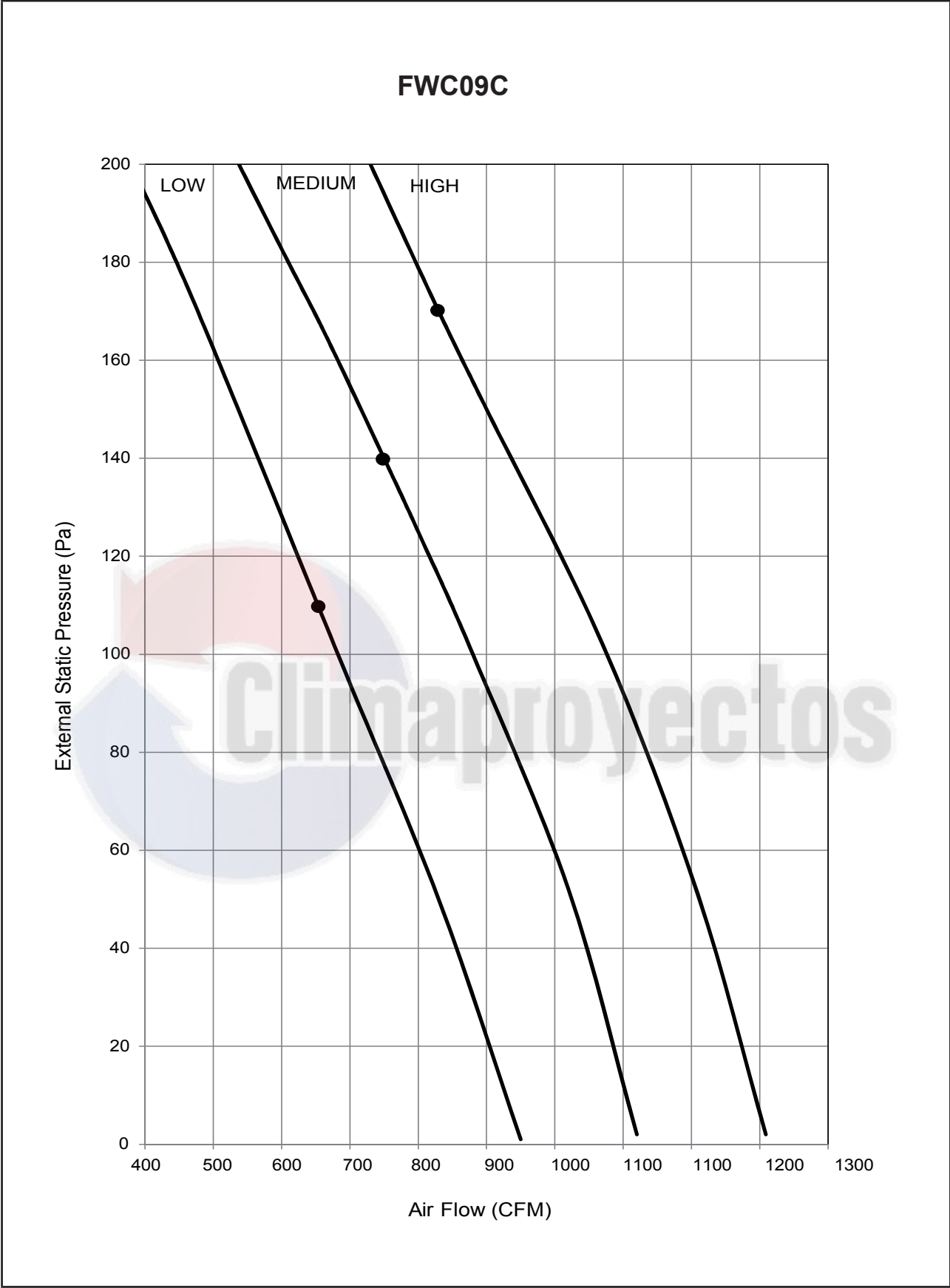

### FWC12C

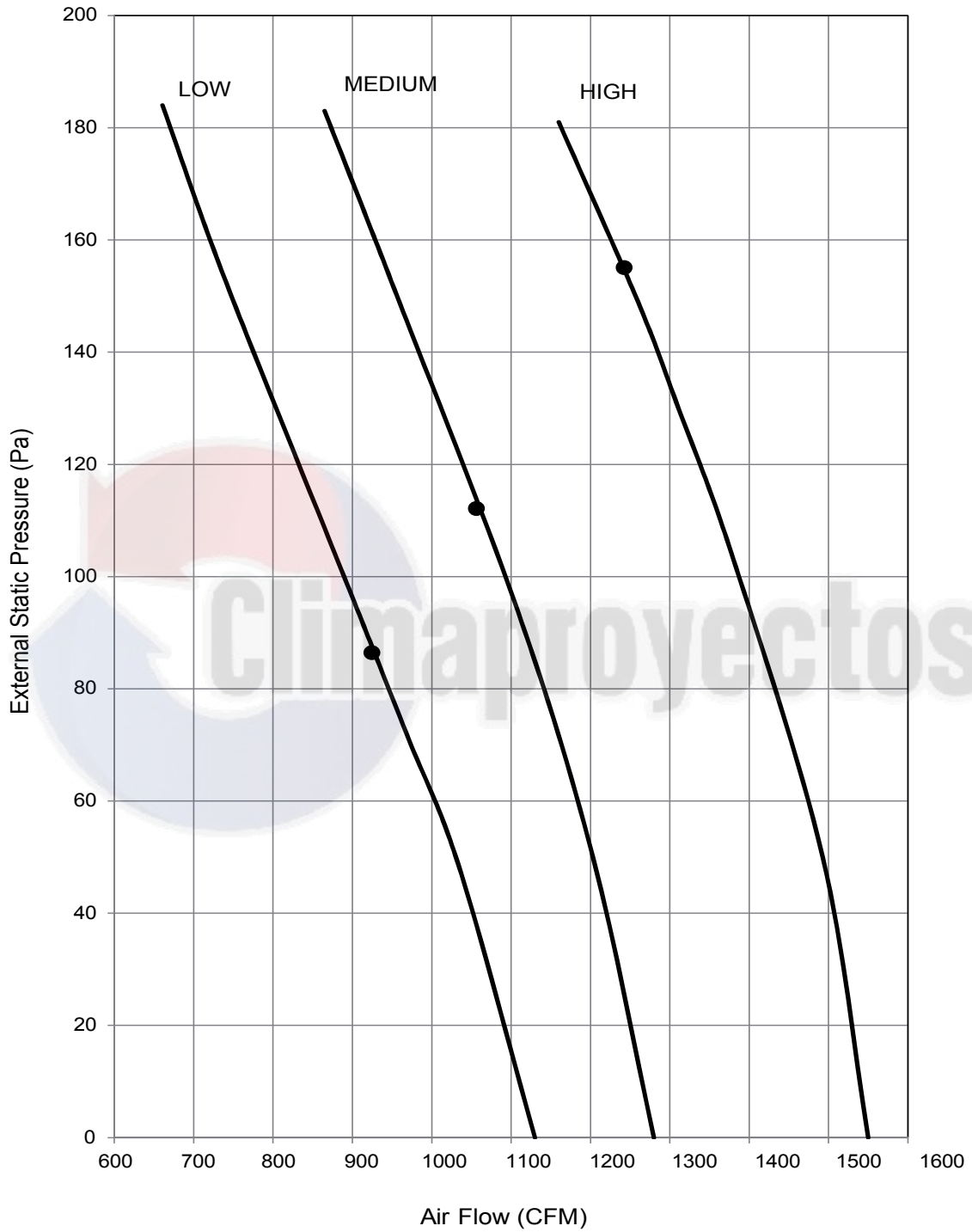

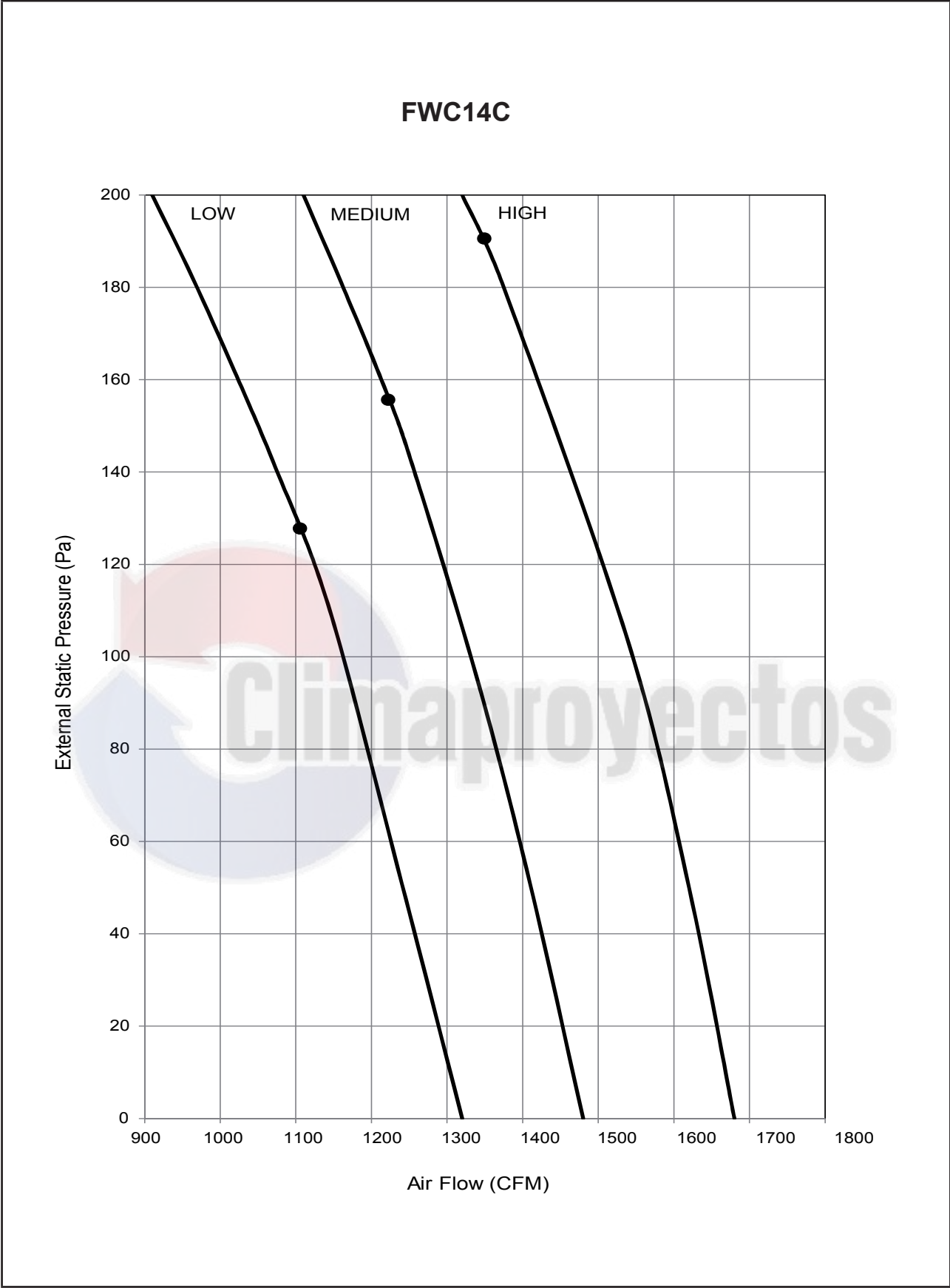



### FWC16C

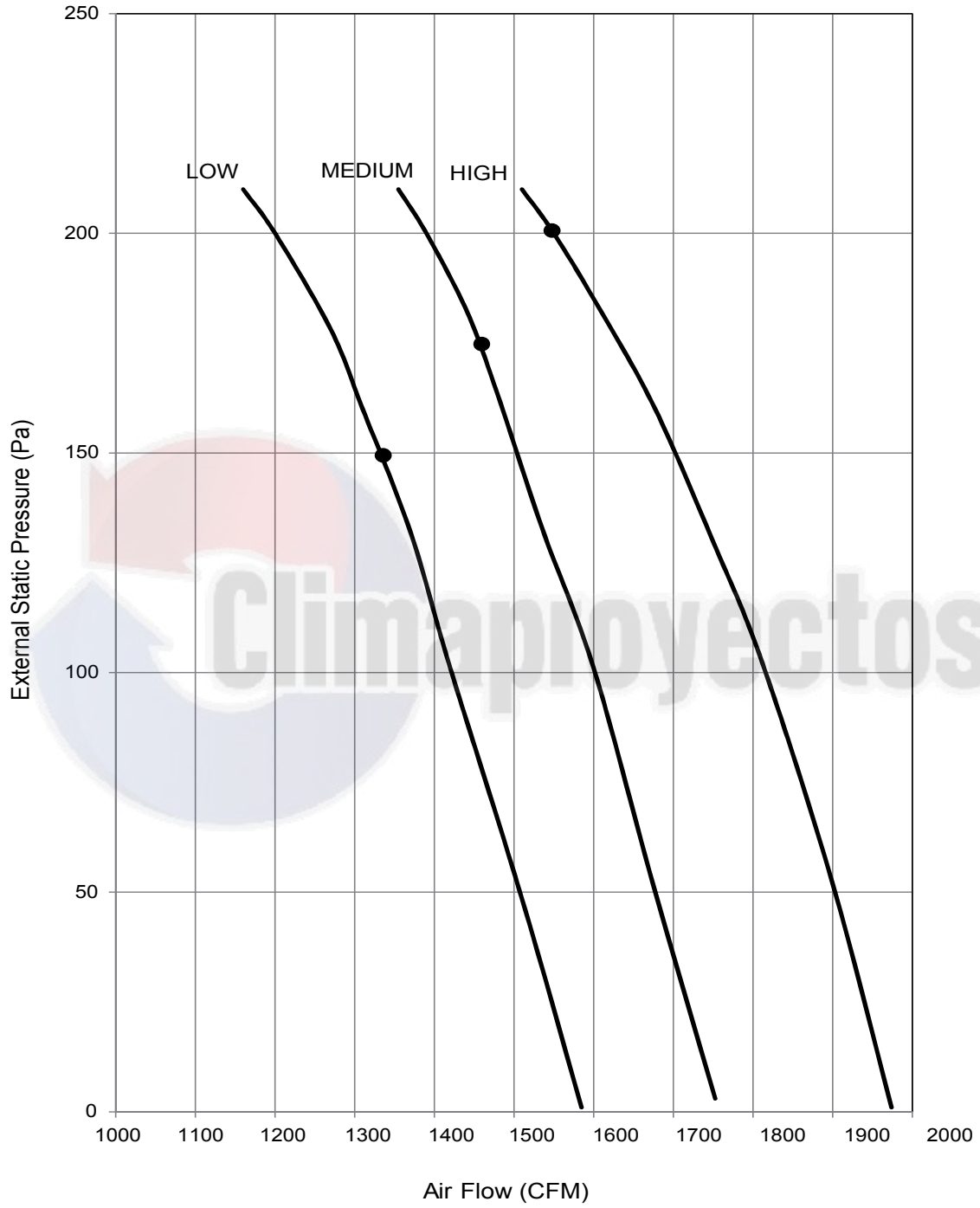

### FWC03G (MSP)

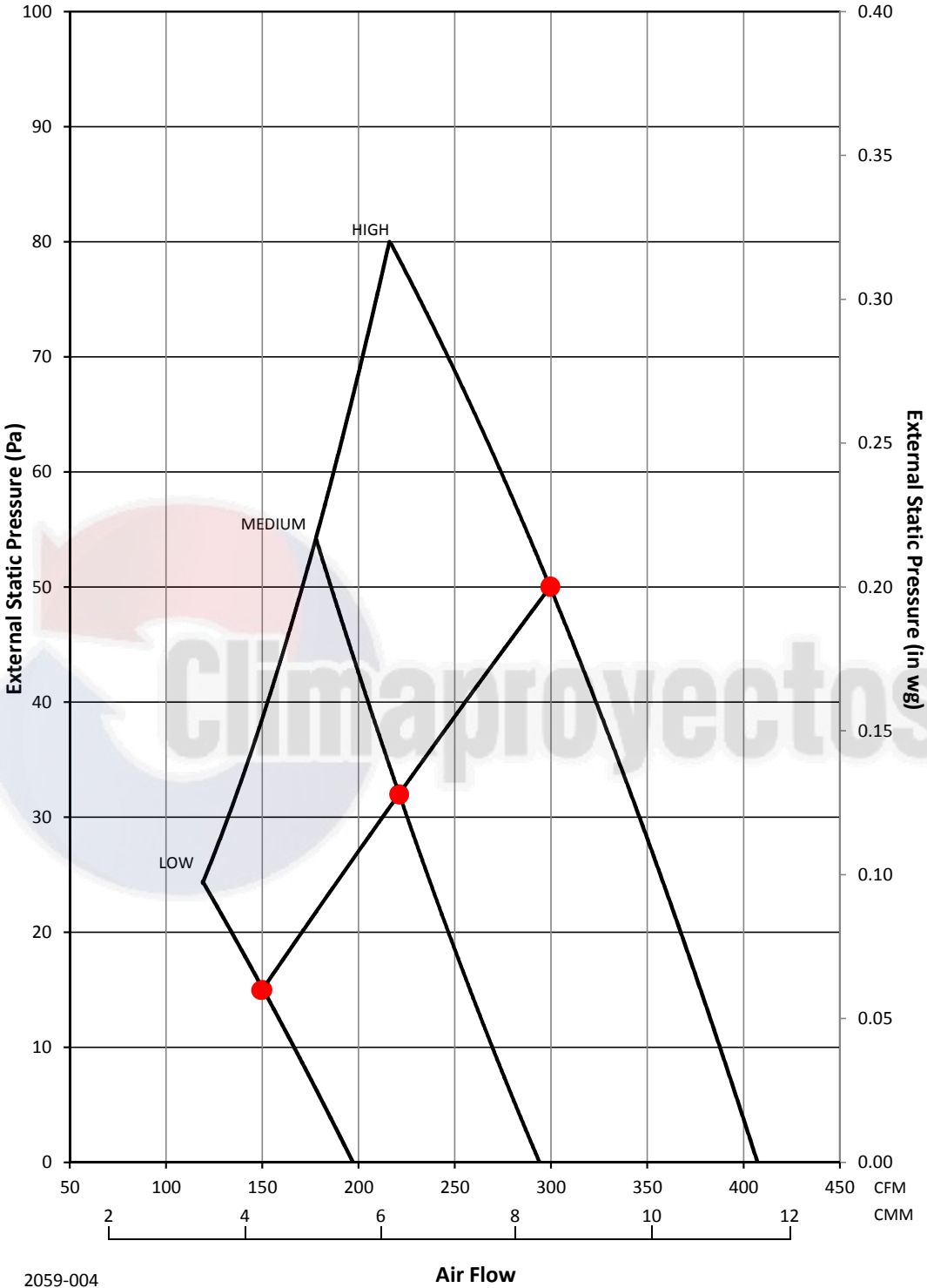

2059-004

Air Flow

### FWC04G (MSP)

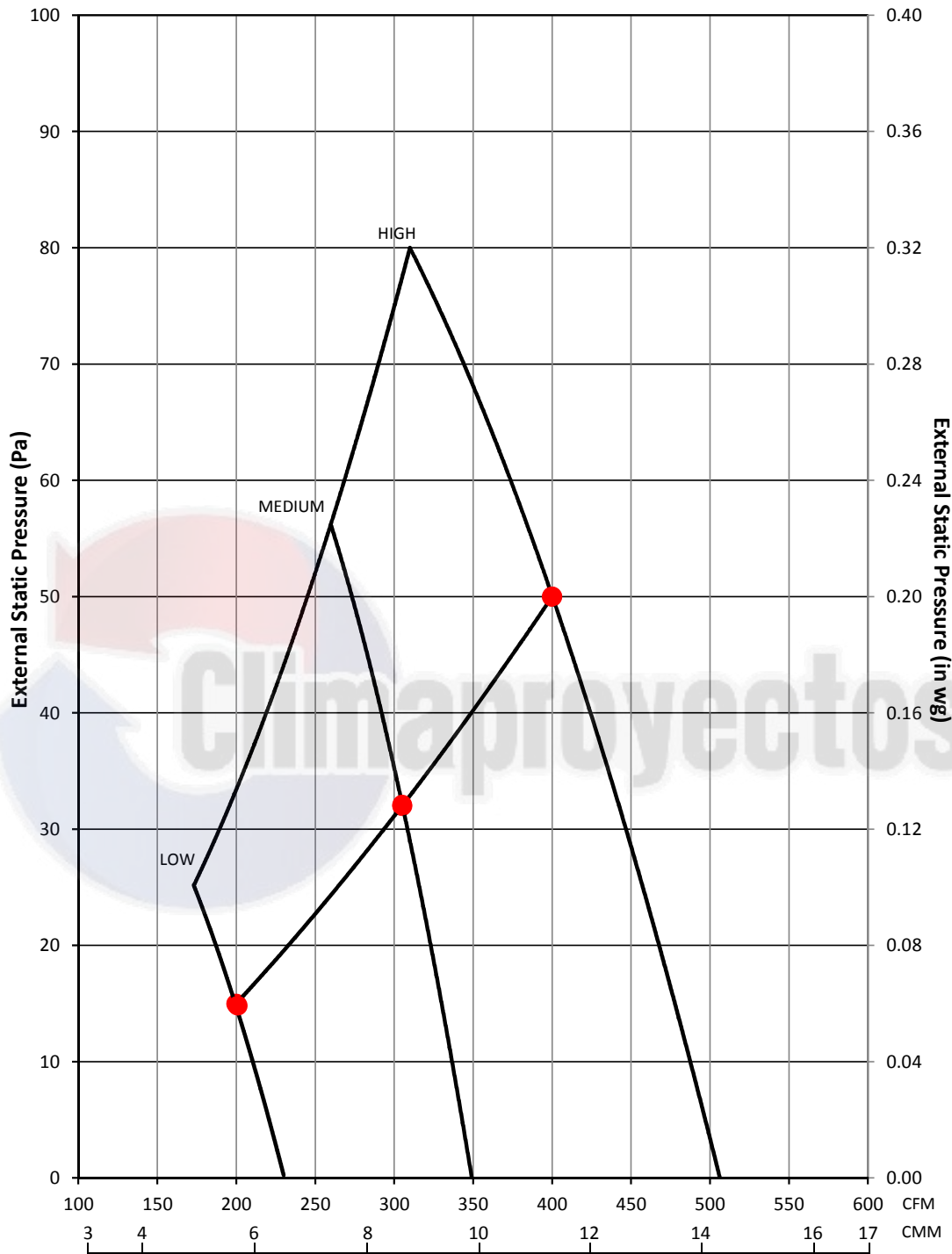

2059-005

Air Flow

### FWC06G (MSP)

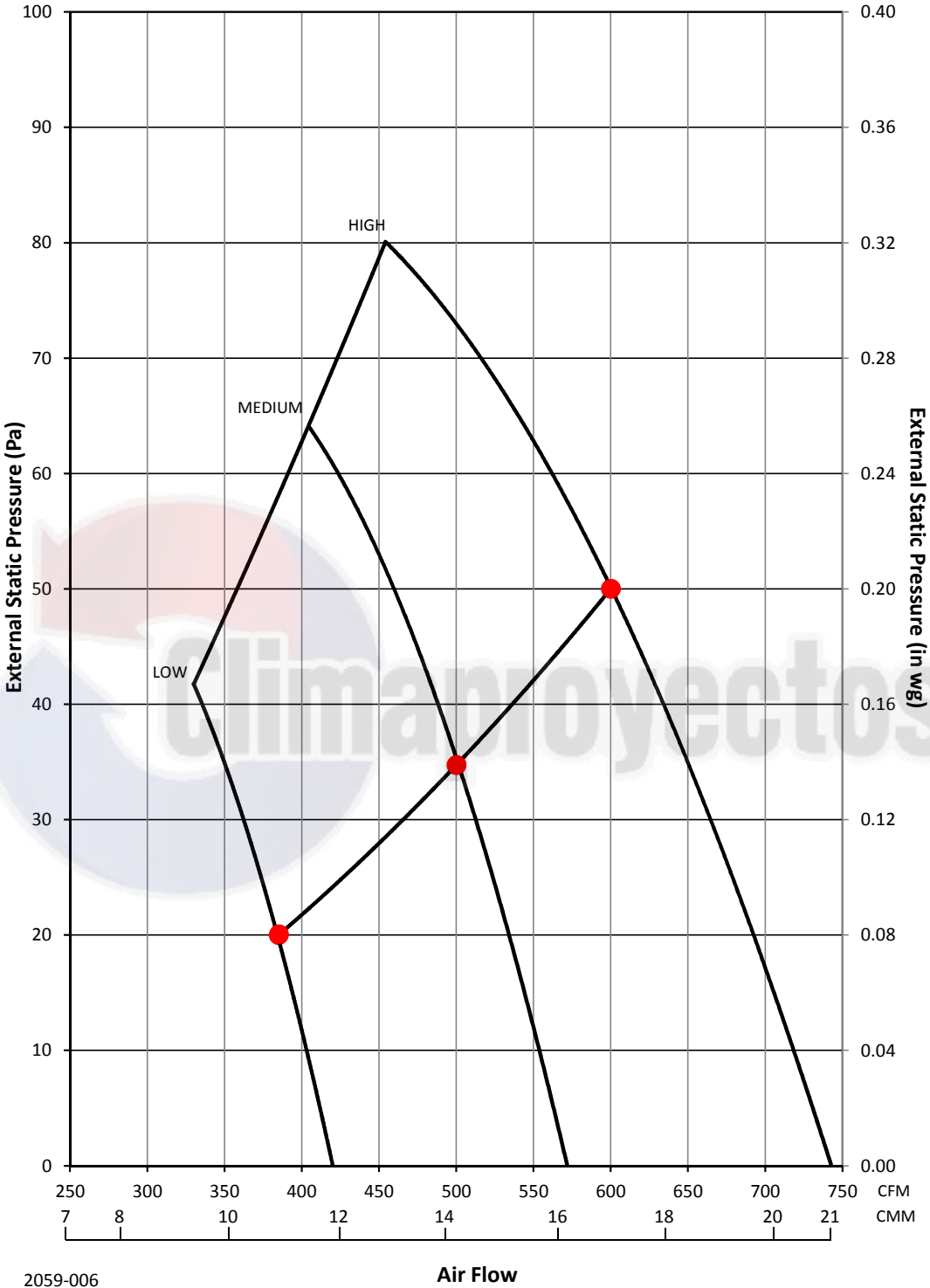

2059-006

Air Flow

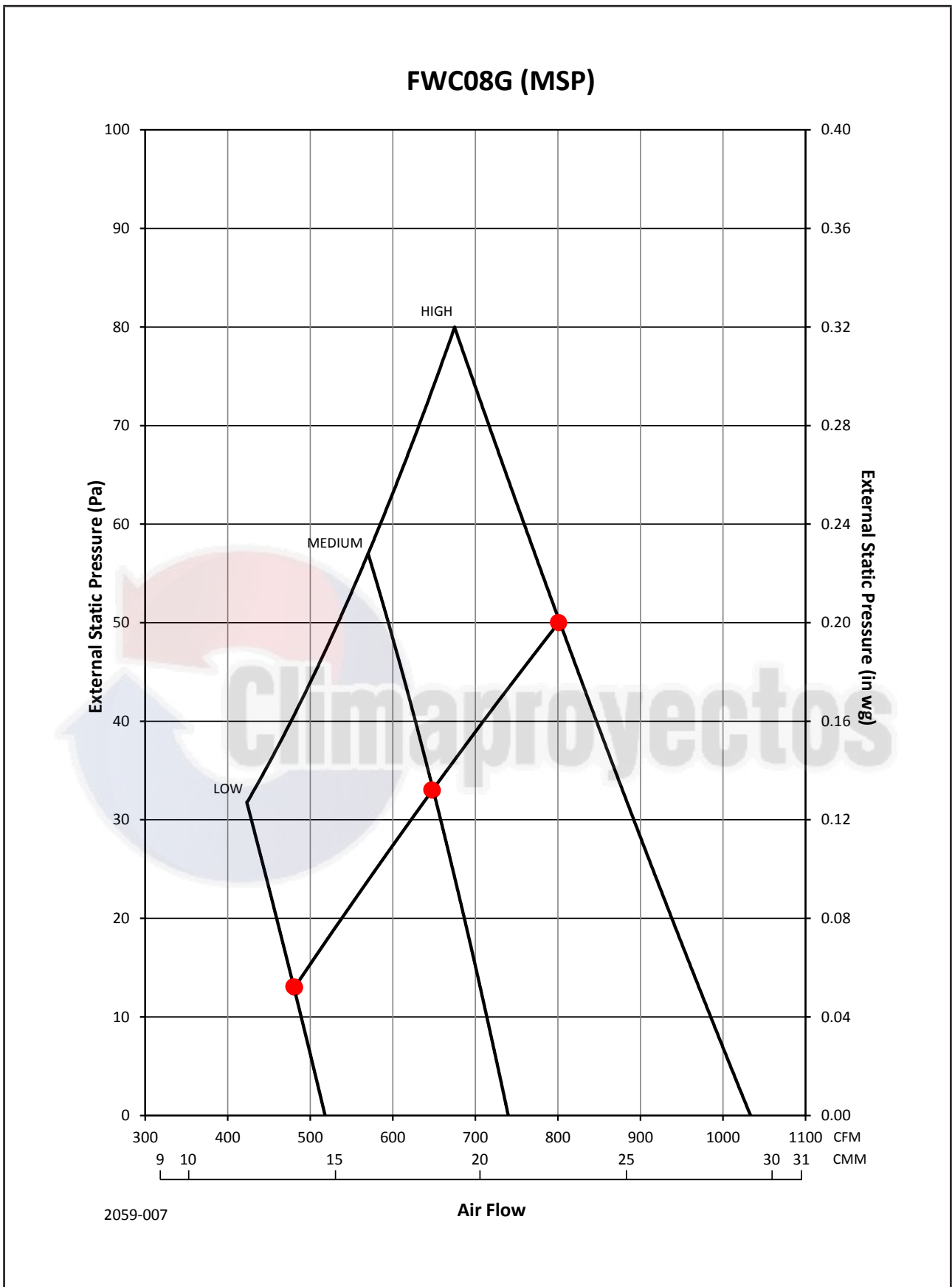

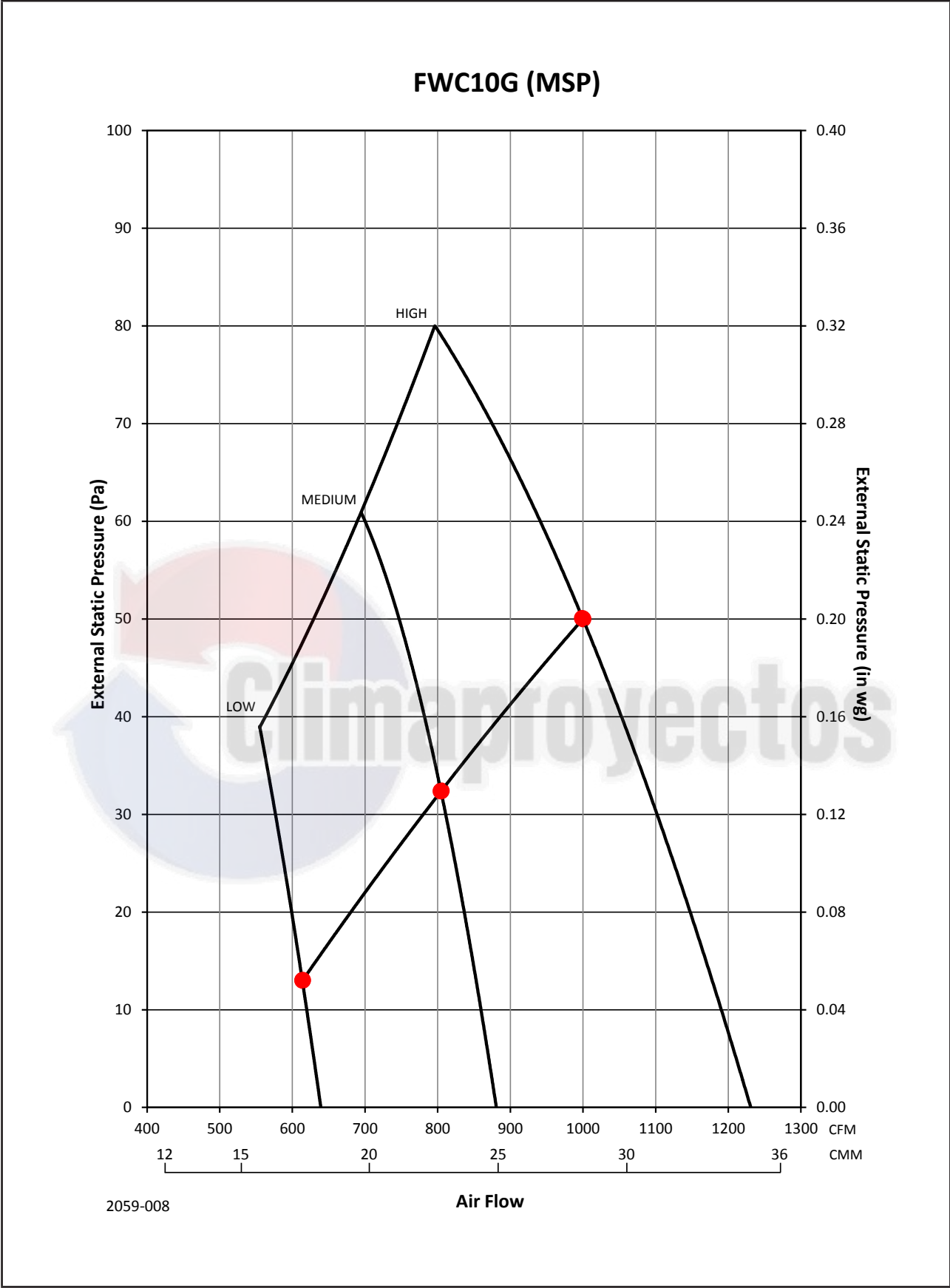

2059-008

Air Flow

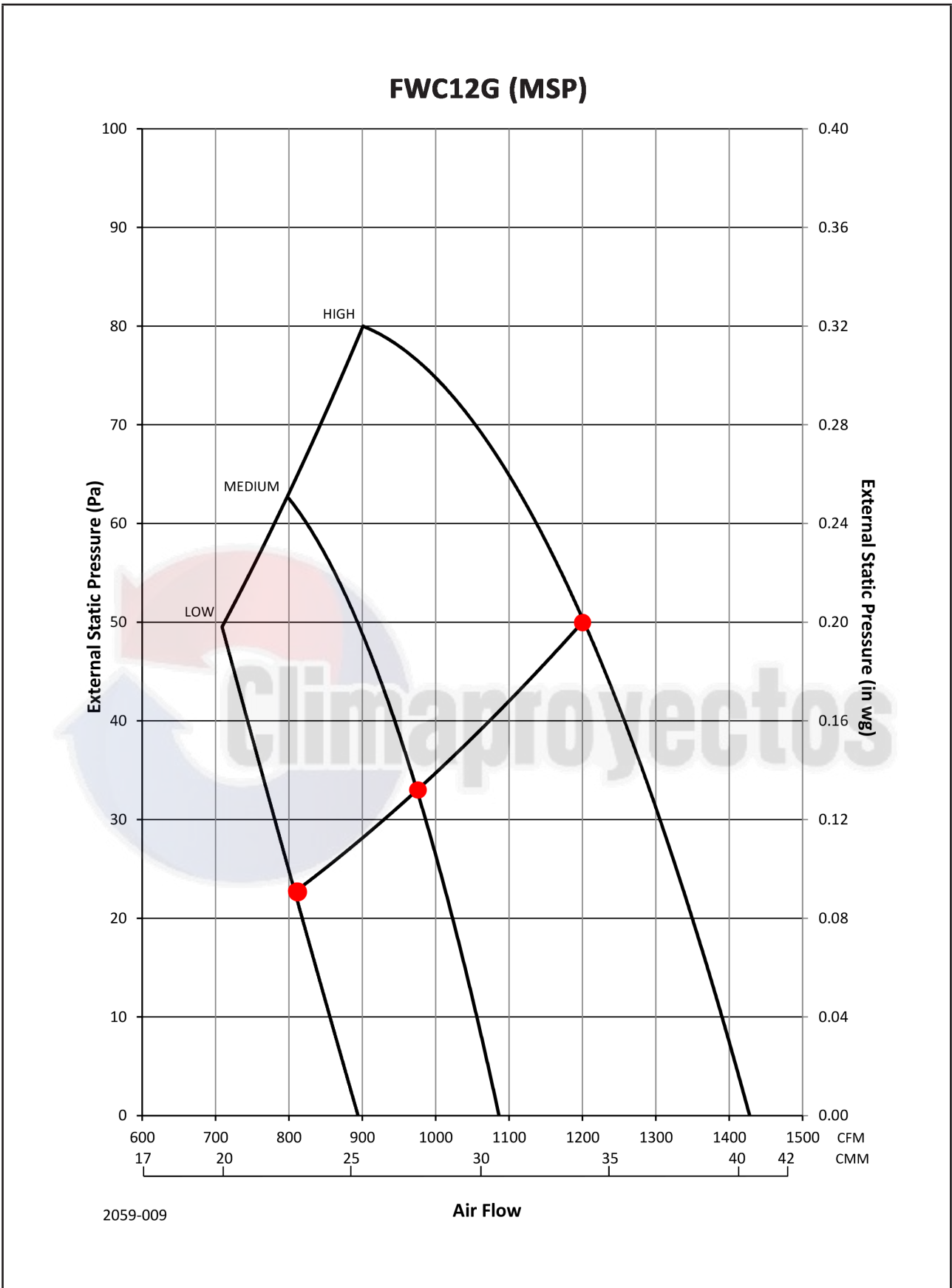

### FWC14G (MSP)

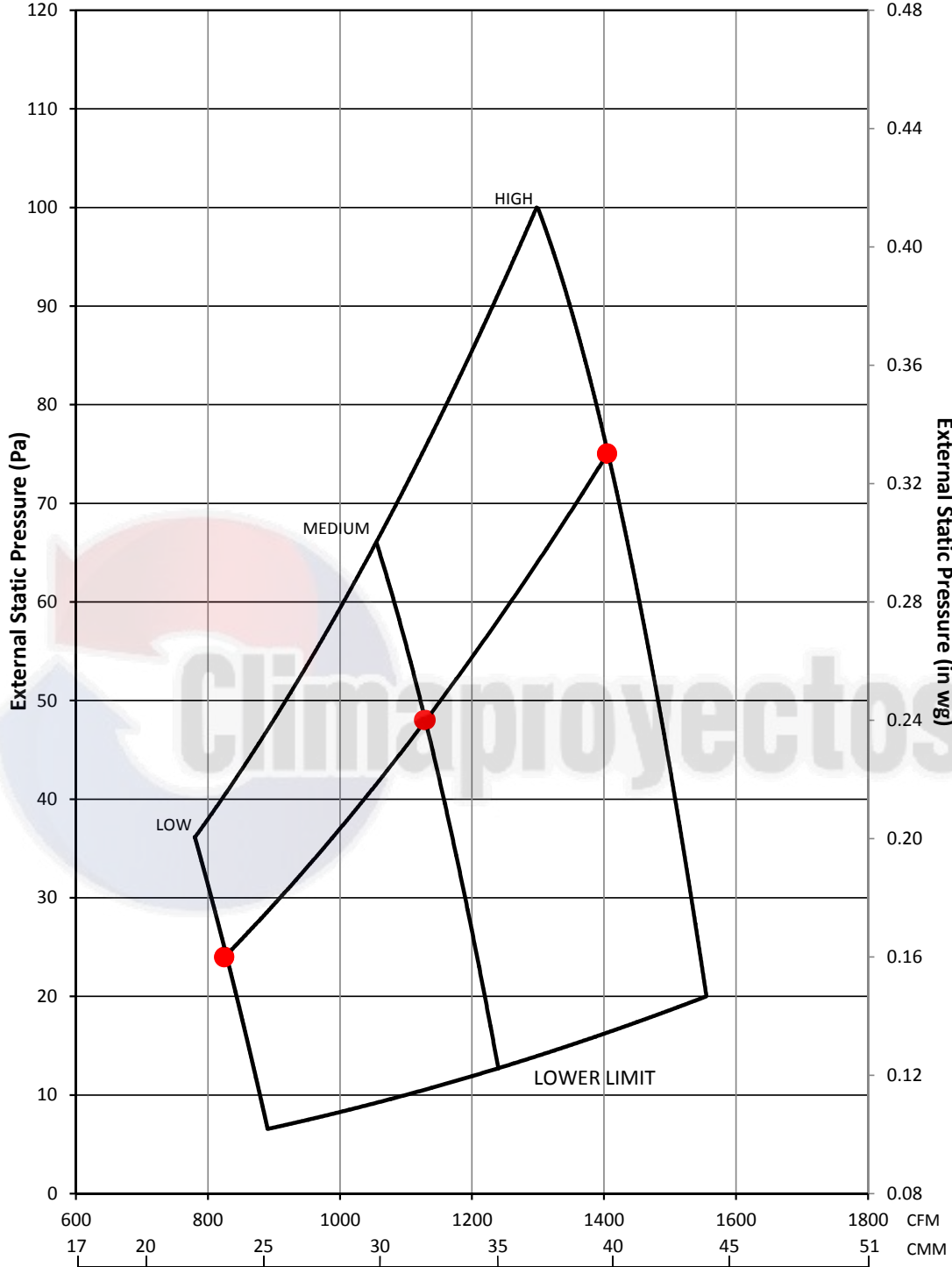

2059-010

Air Flow



### FWC16G (MSP)

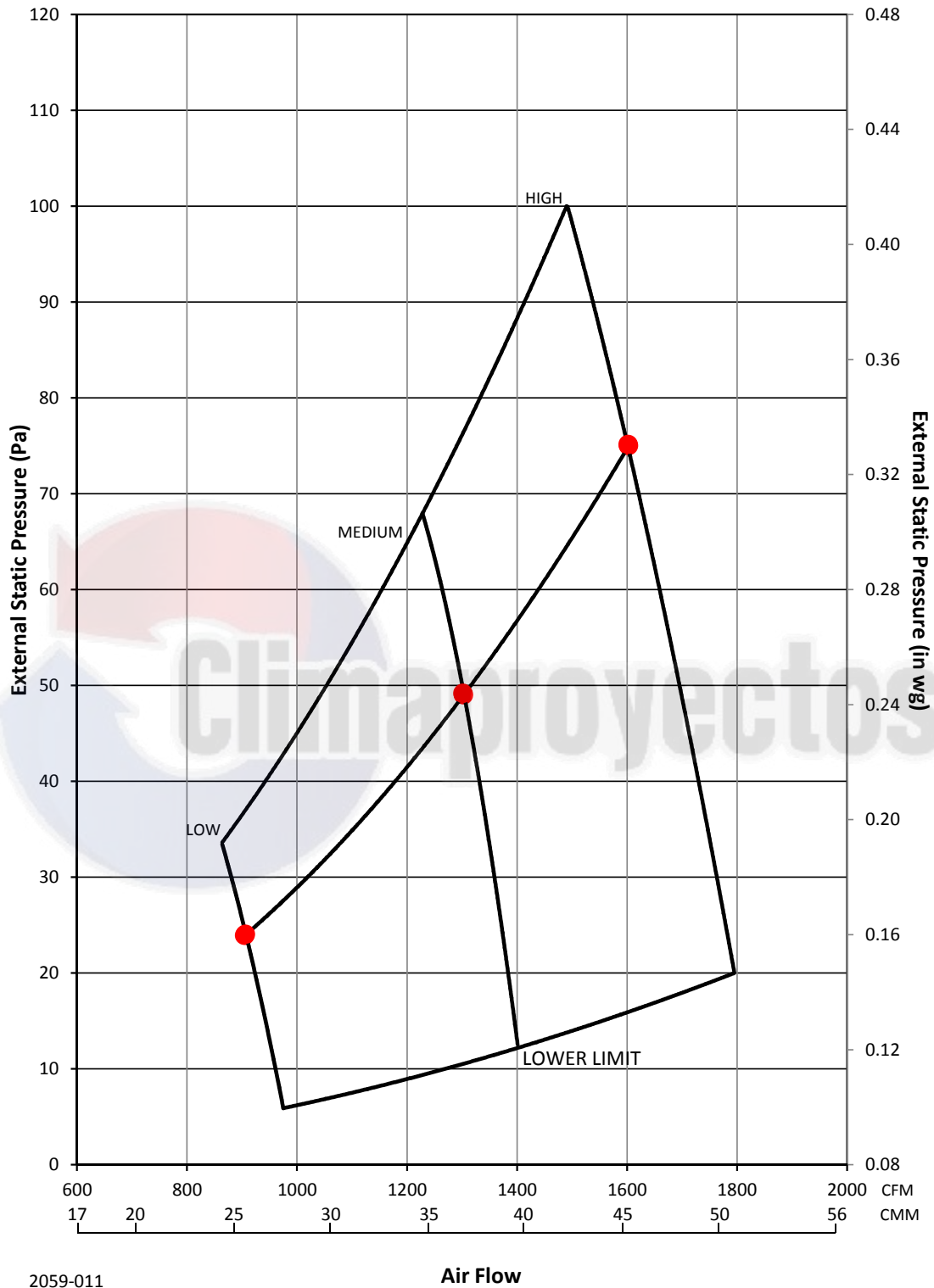

2059-011

### FWC18G (MSP)

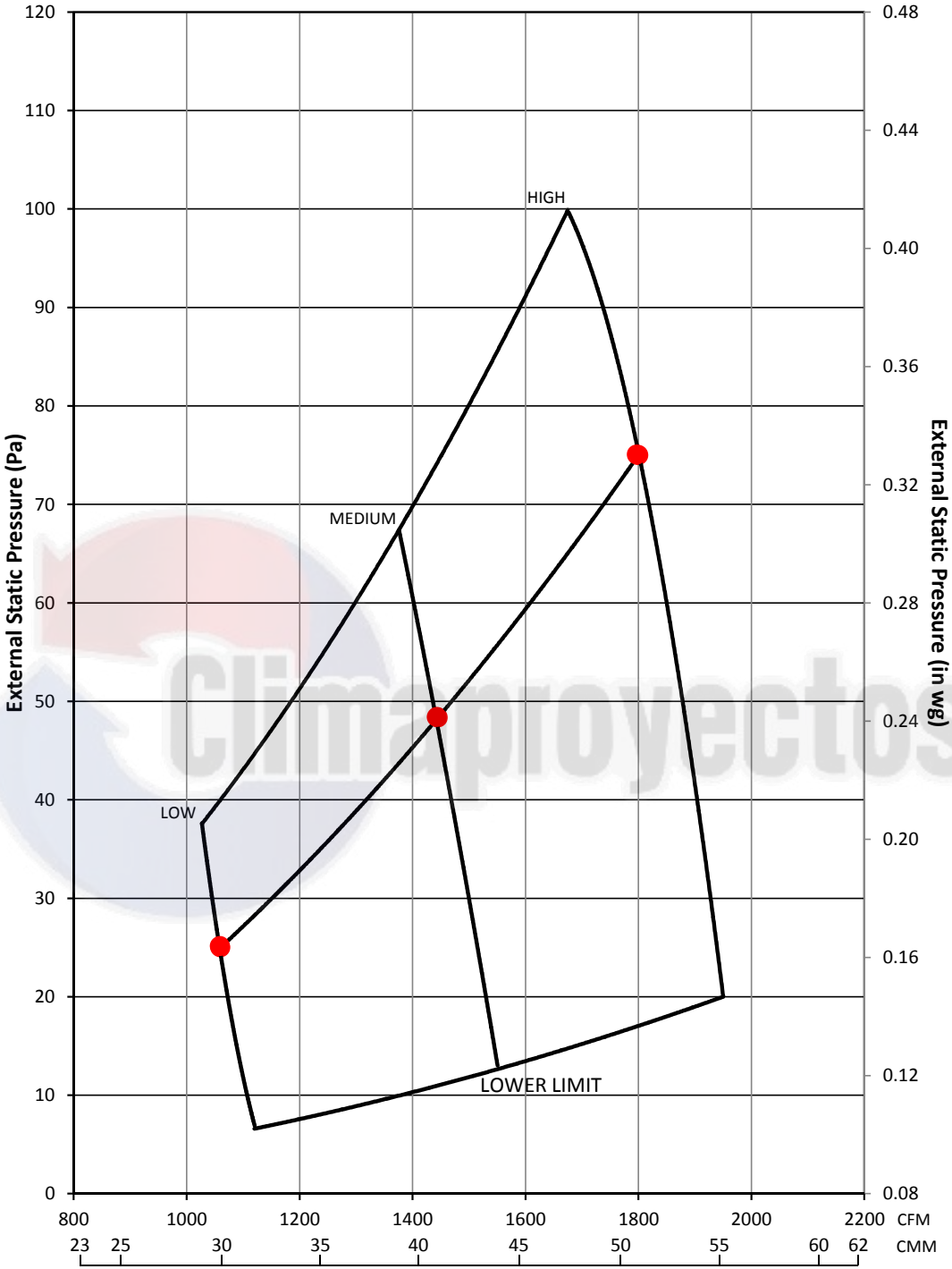

2059-012

Air Flow

### FWC20G (MSP)

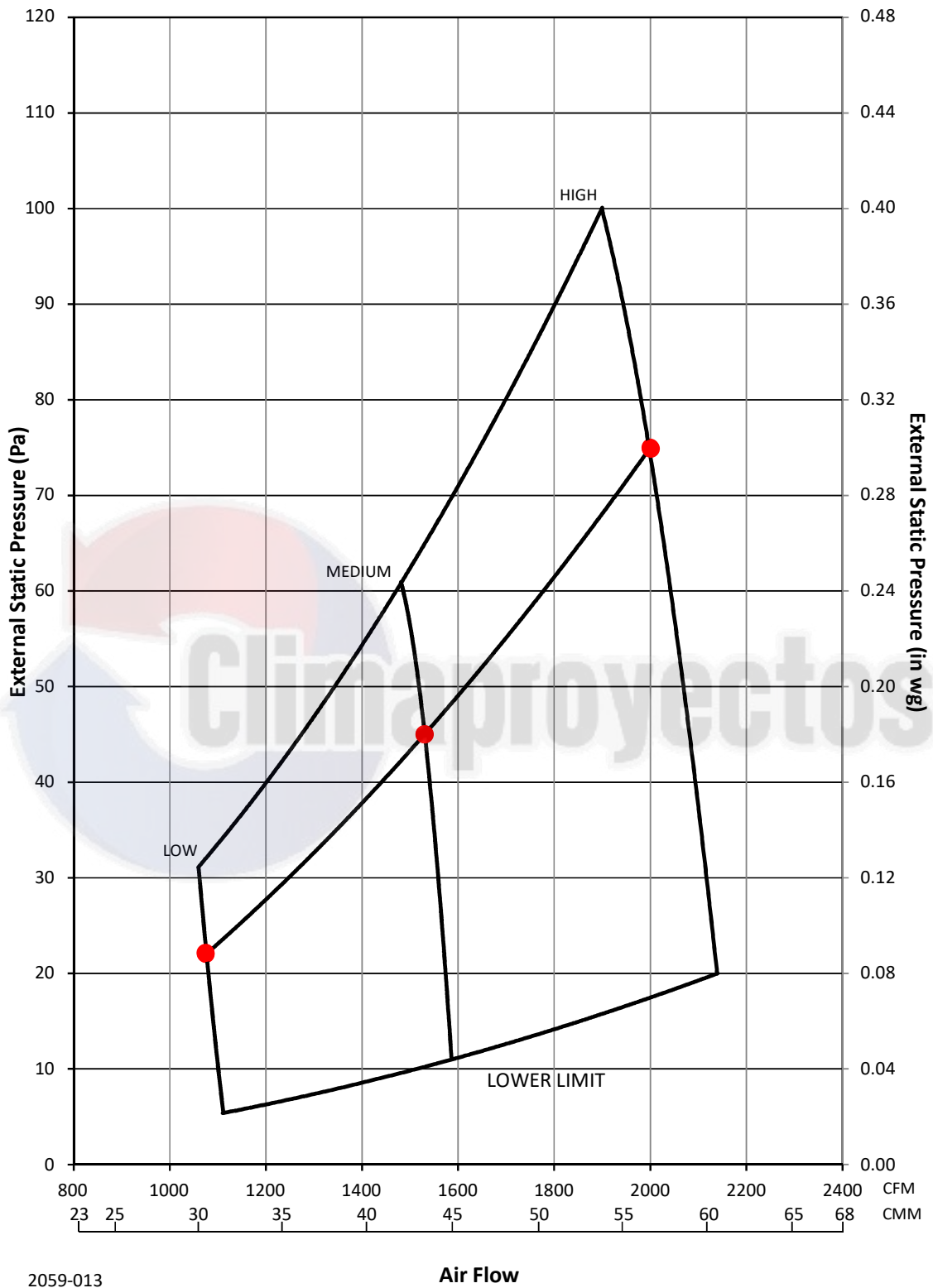

2059-013

Air Flow

### FWC02G EC(LSP)

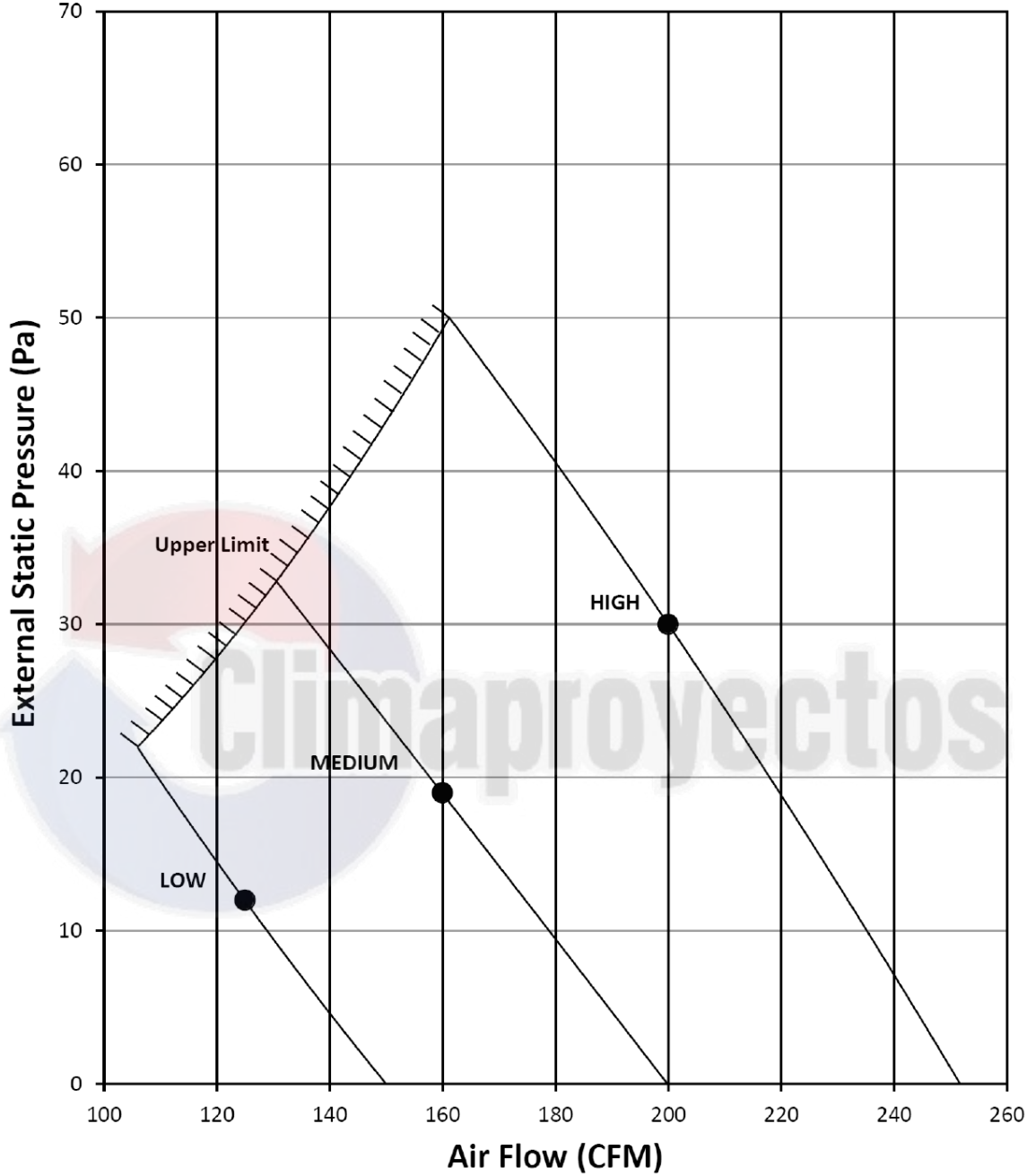

### FWC03G EC(LSP)

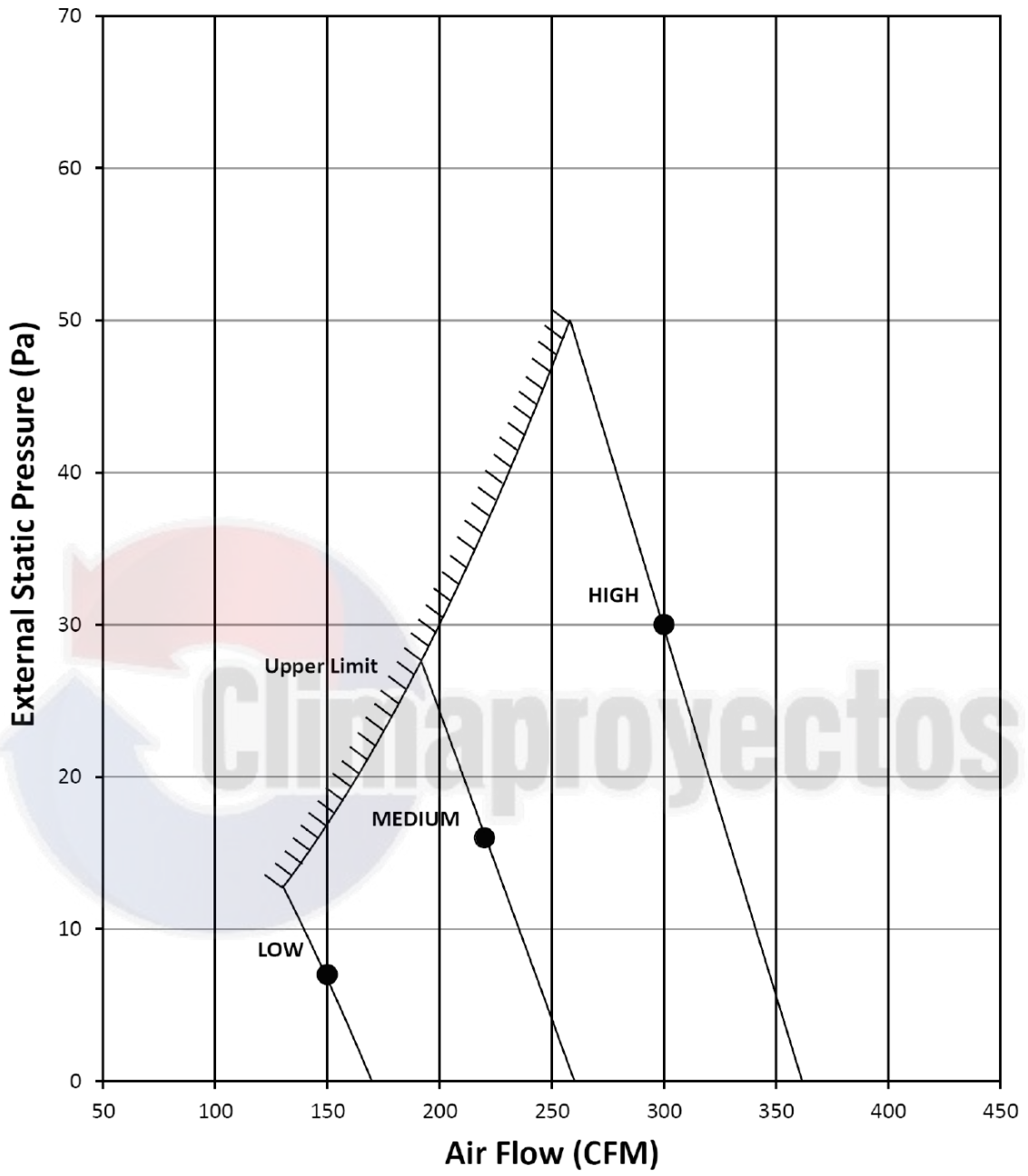

### FWC04G EC(LSP)

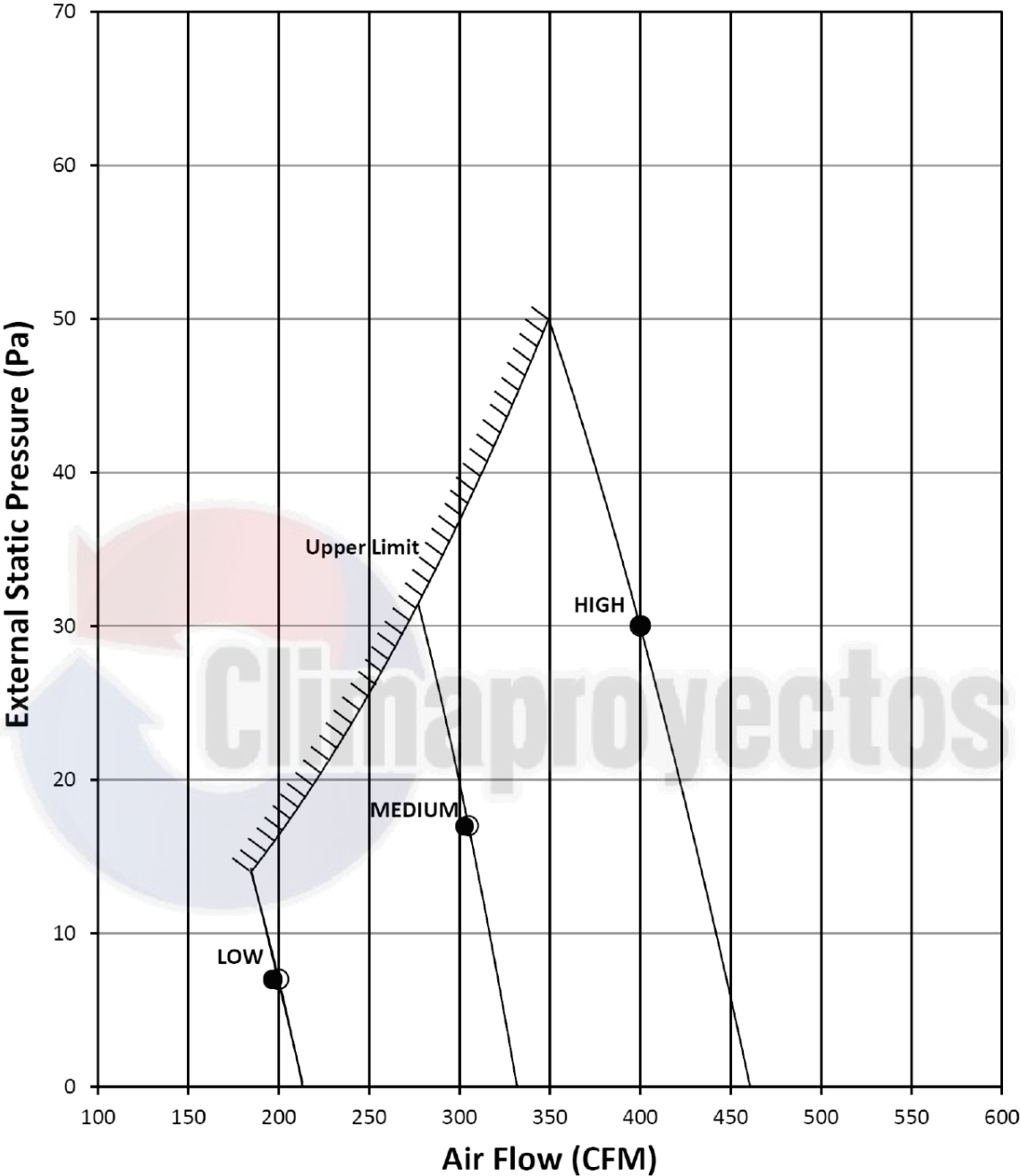

### FWC06G EC(LSP)

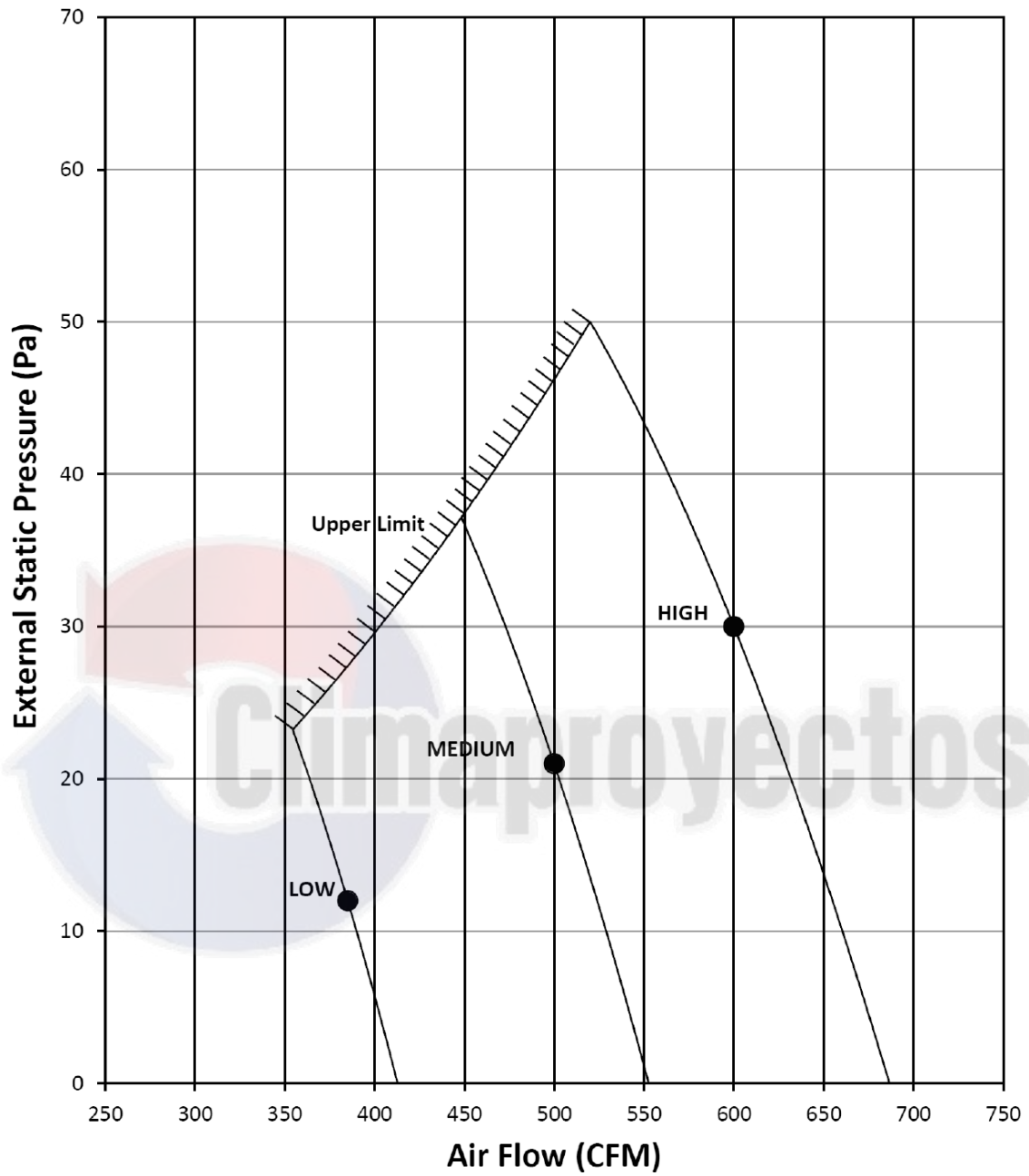

### FWC08G EC(LSP)

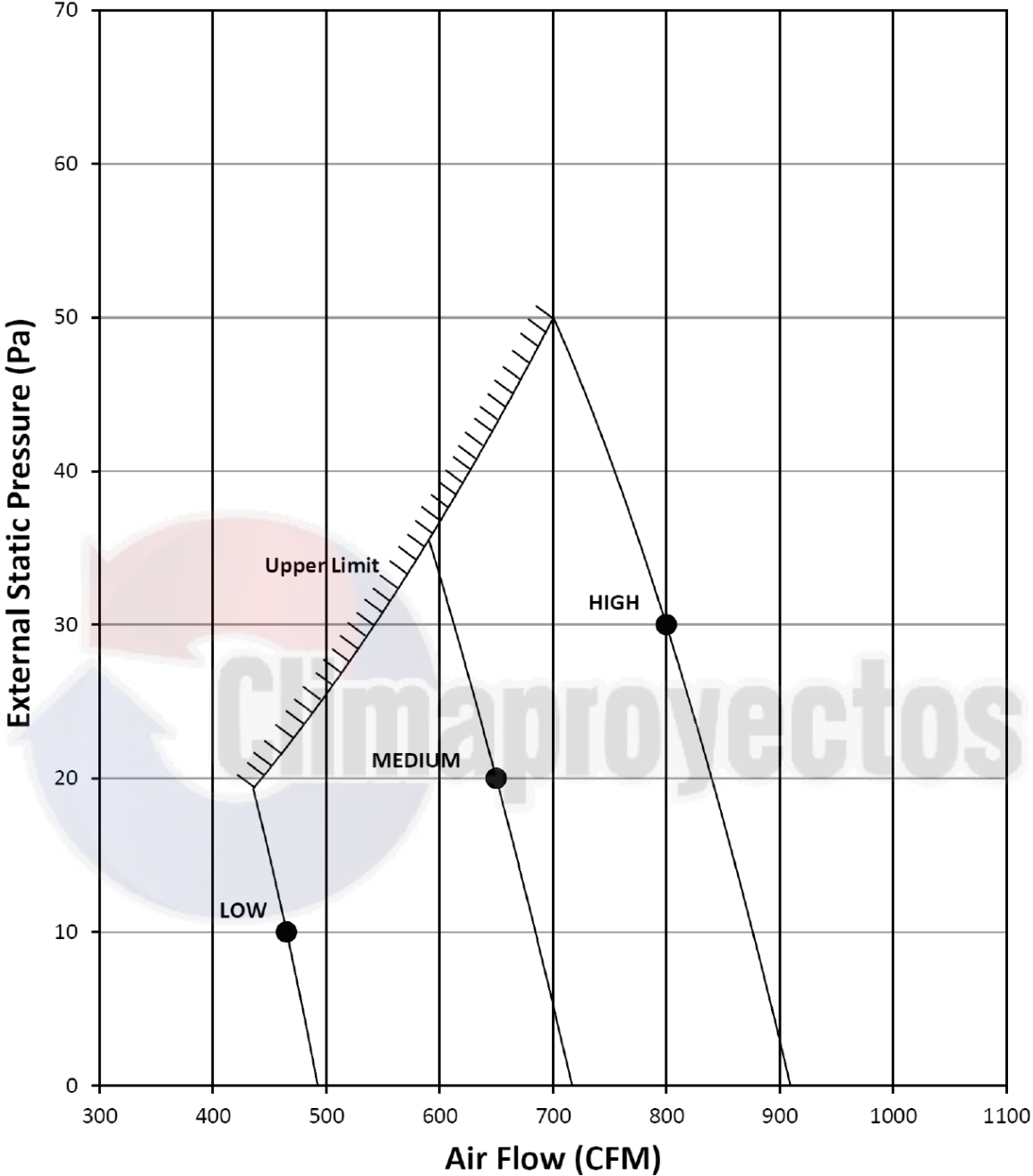



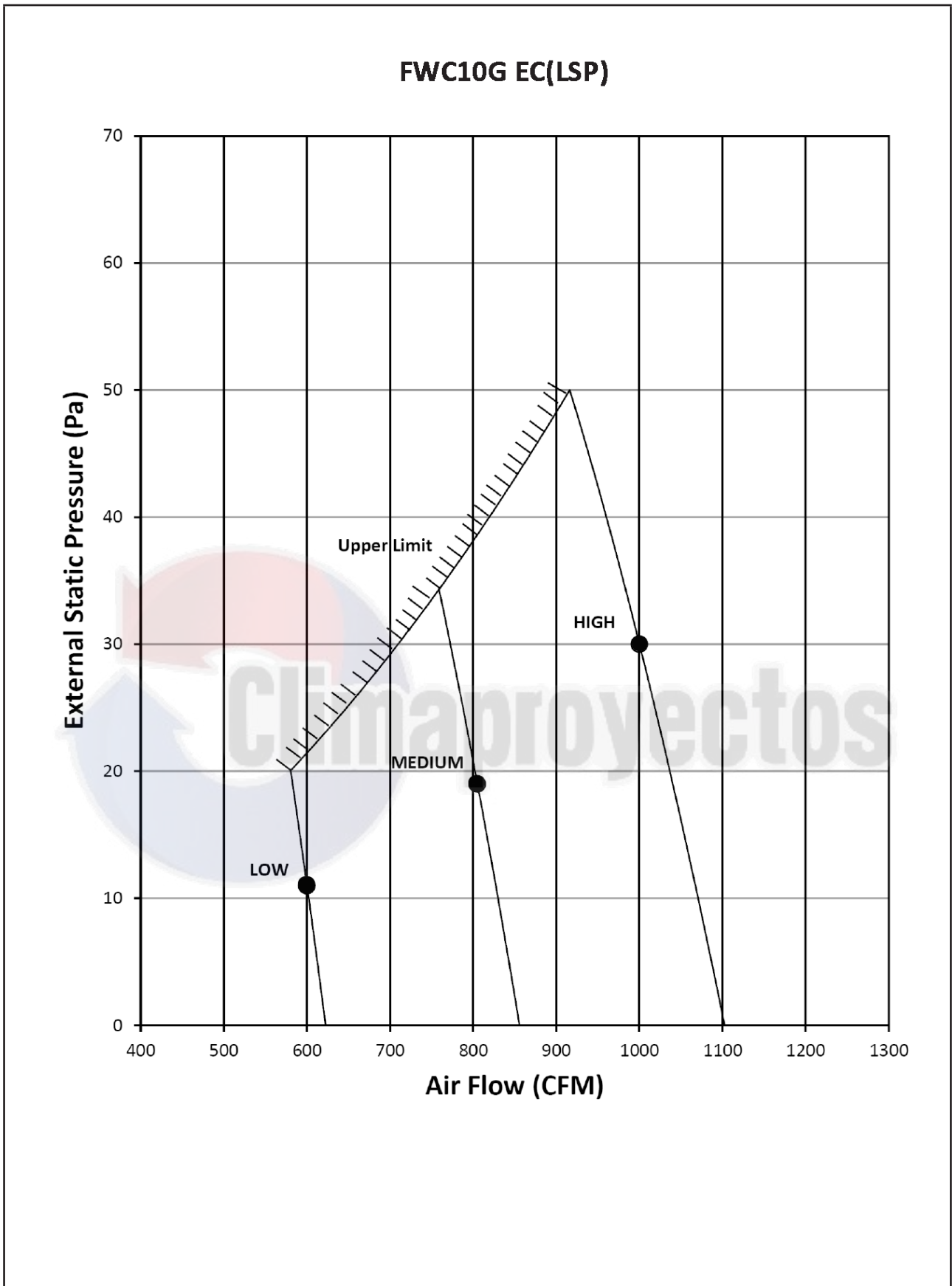

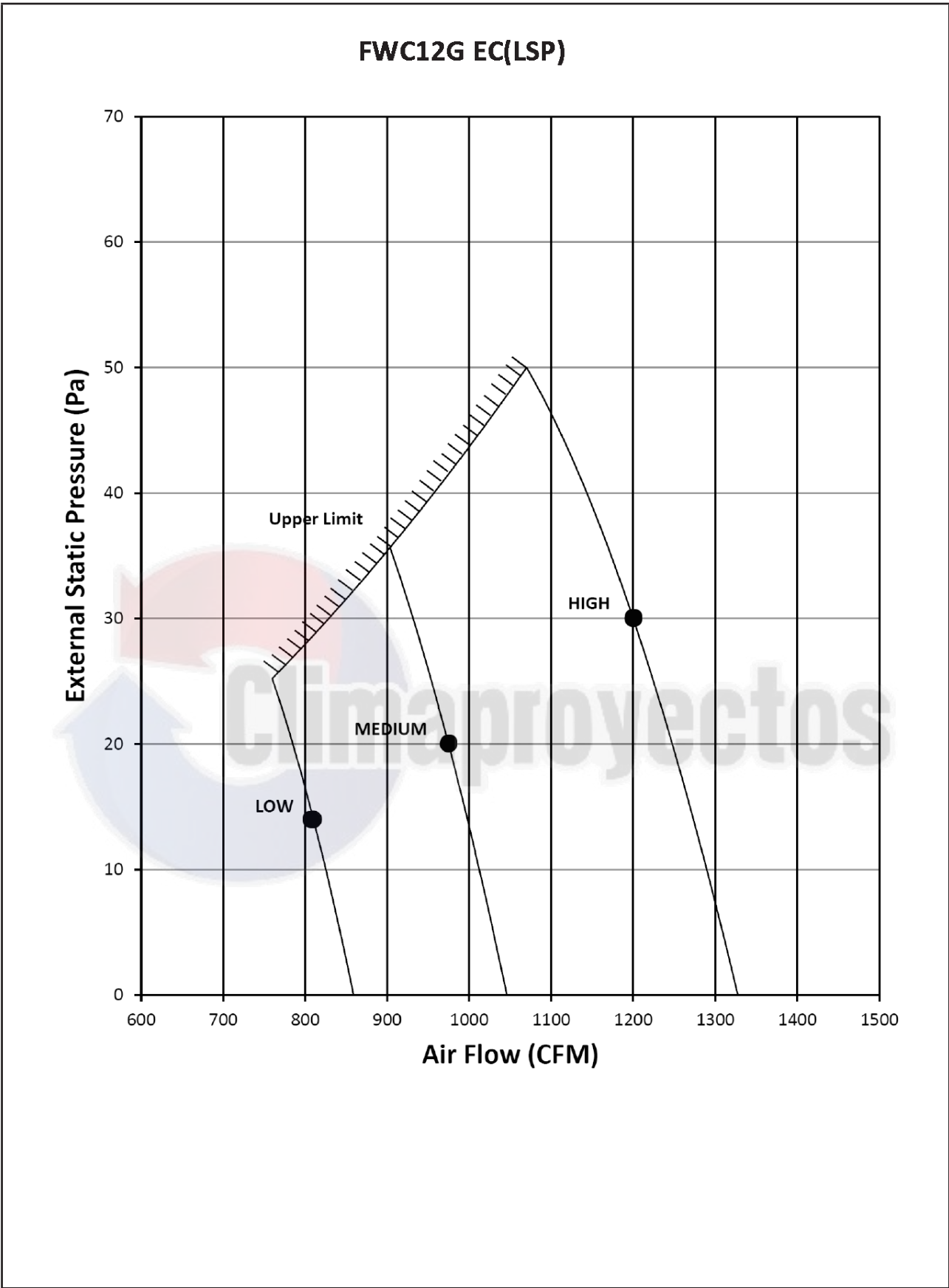

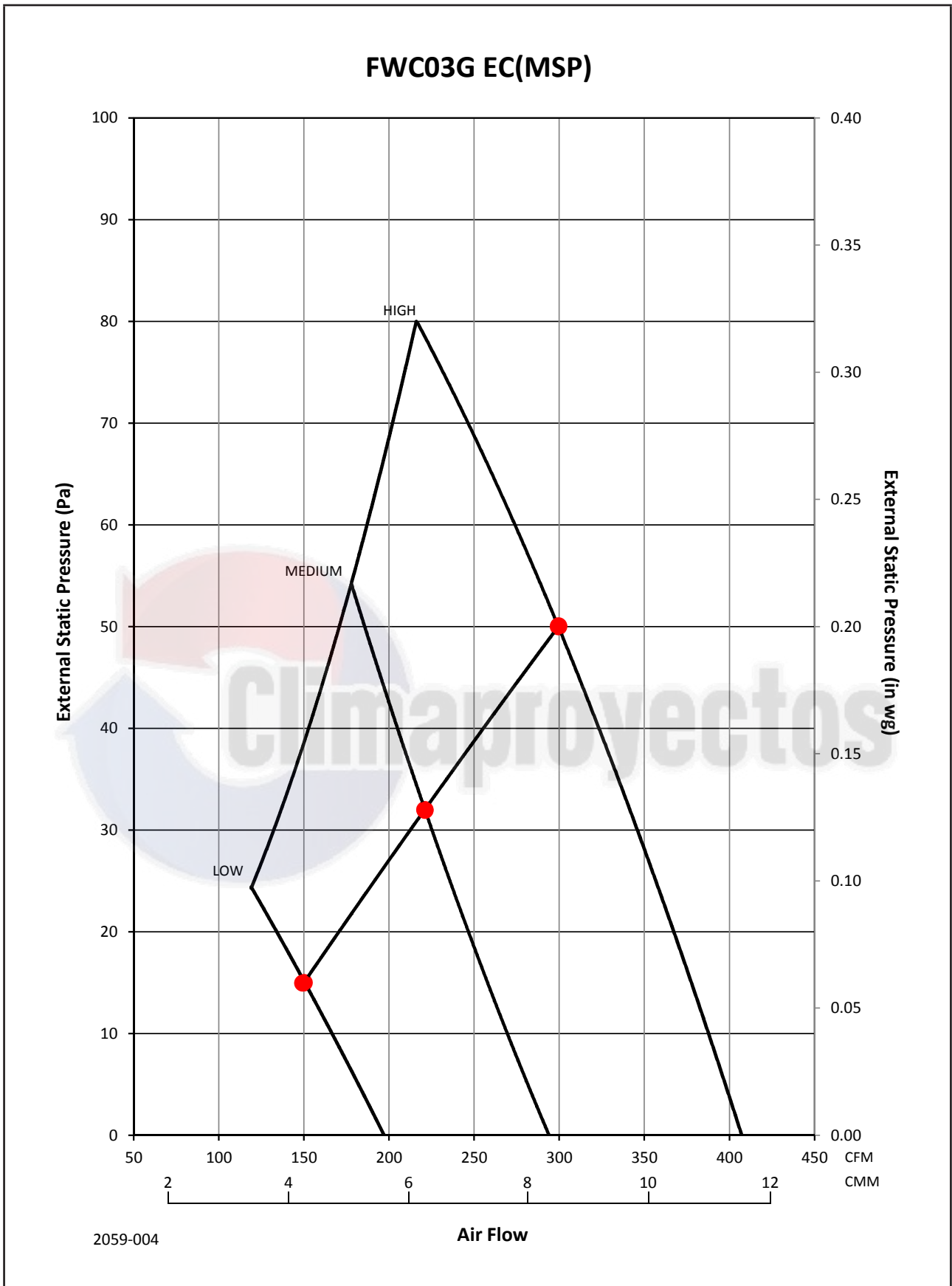

### FWC04G EC(MSP)

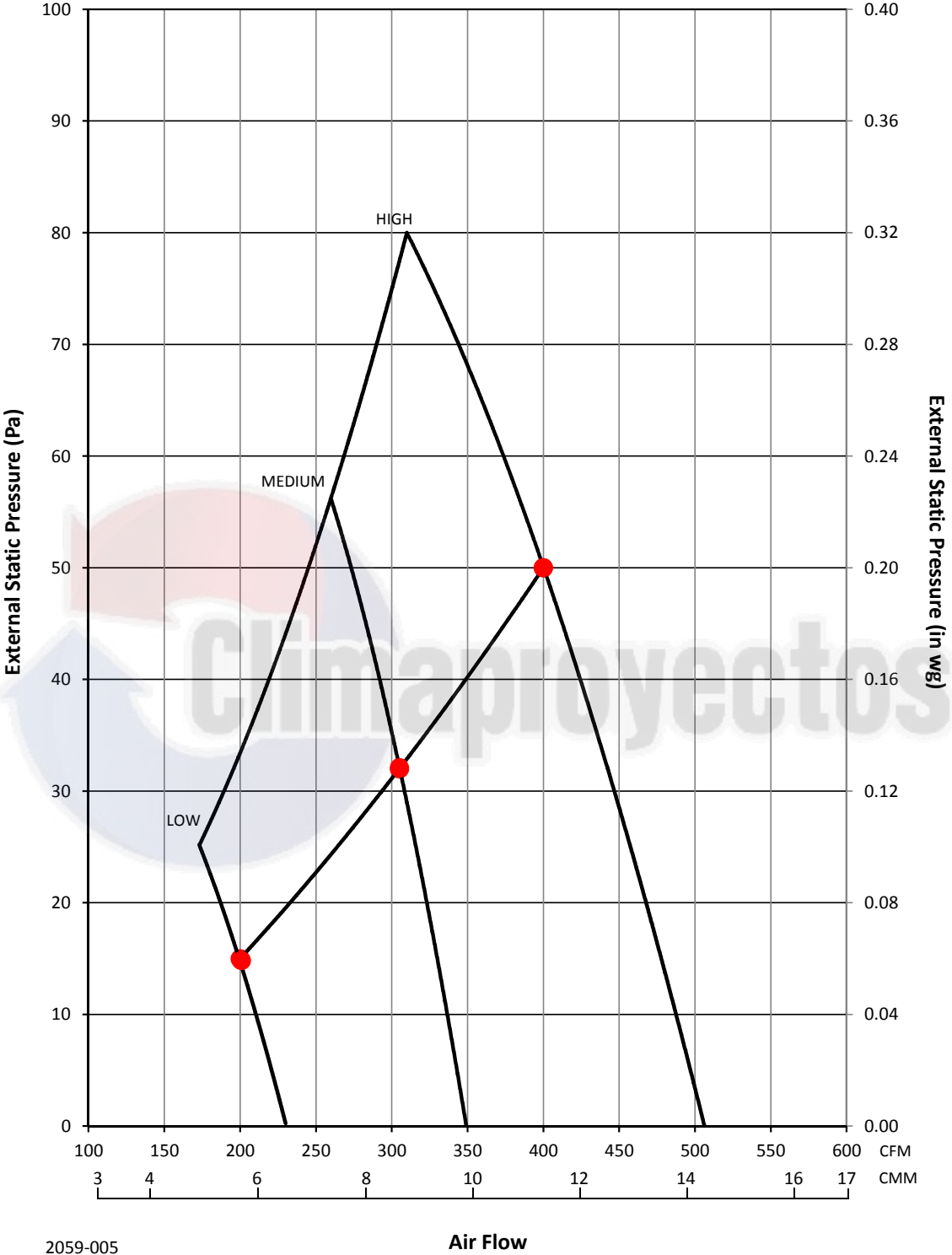

2059-005

Air Flow

### FWC06G EC(MSP)

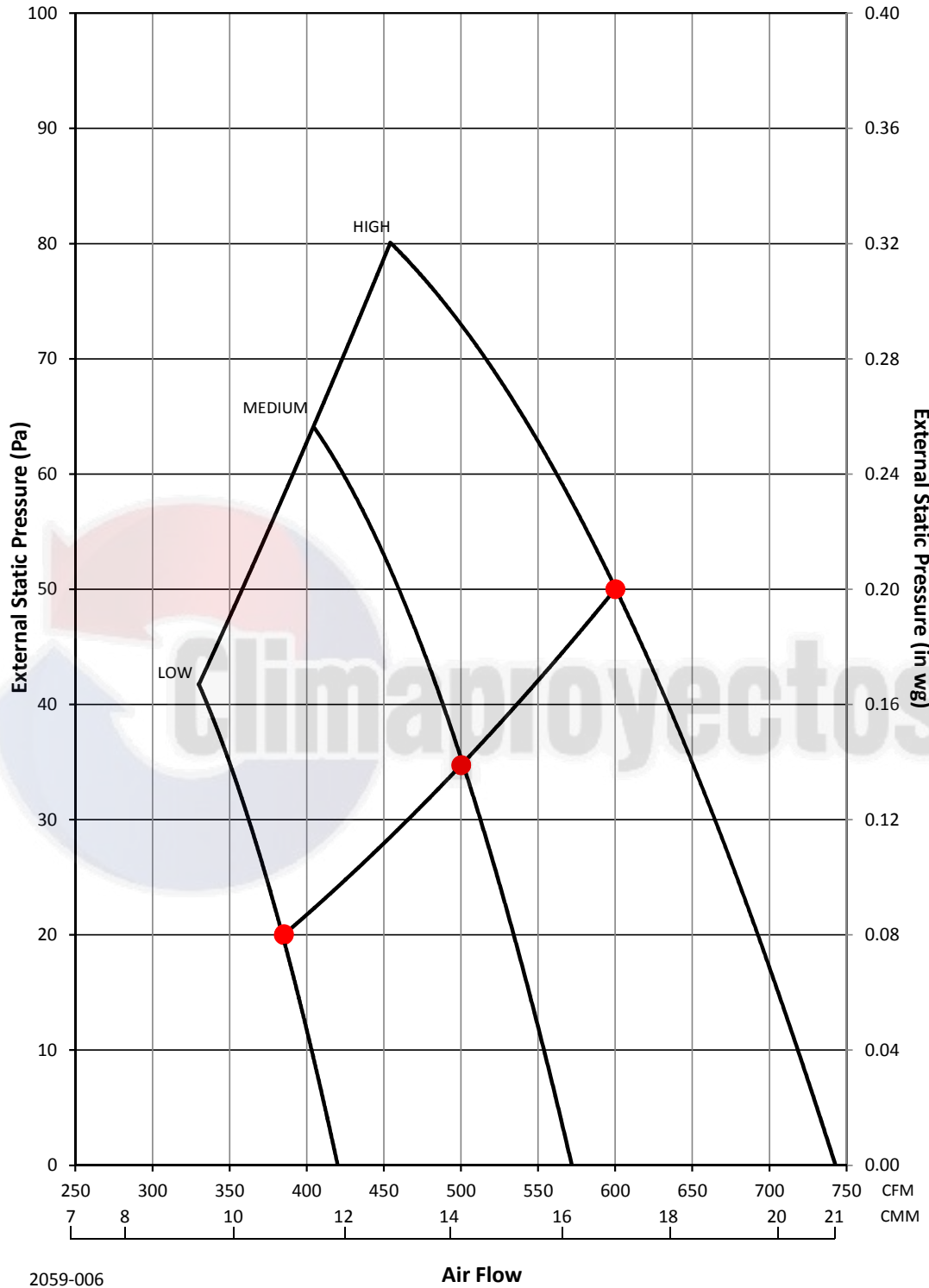

2059-006

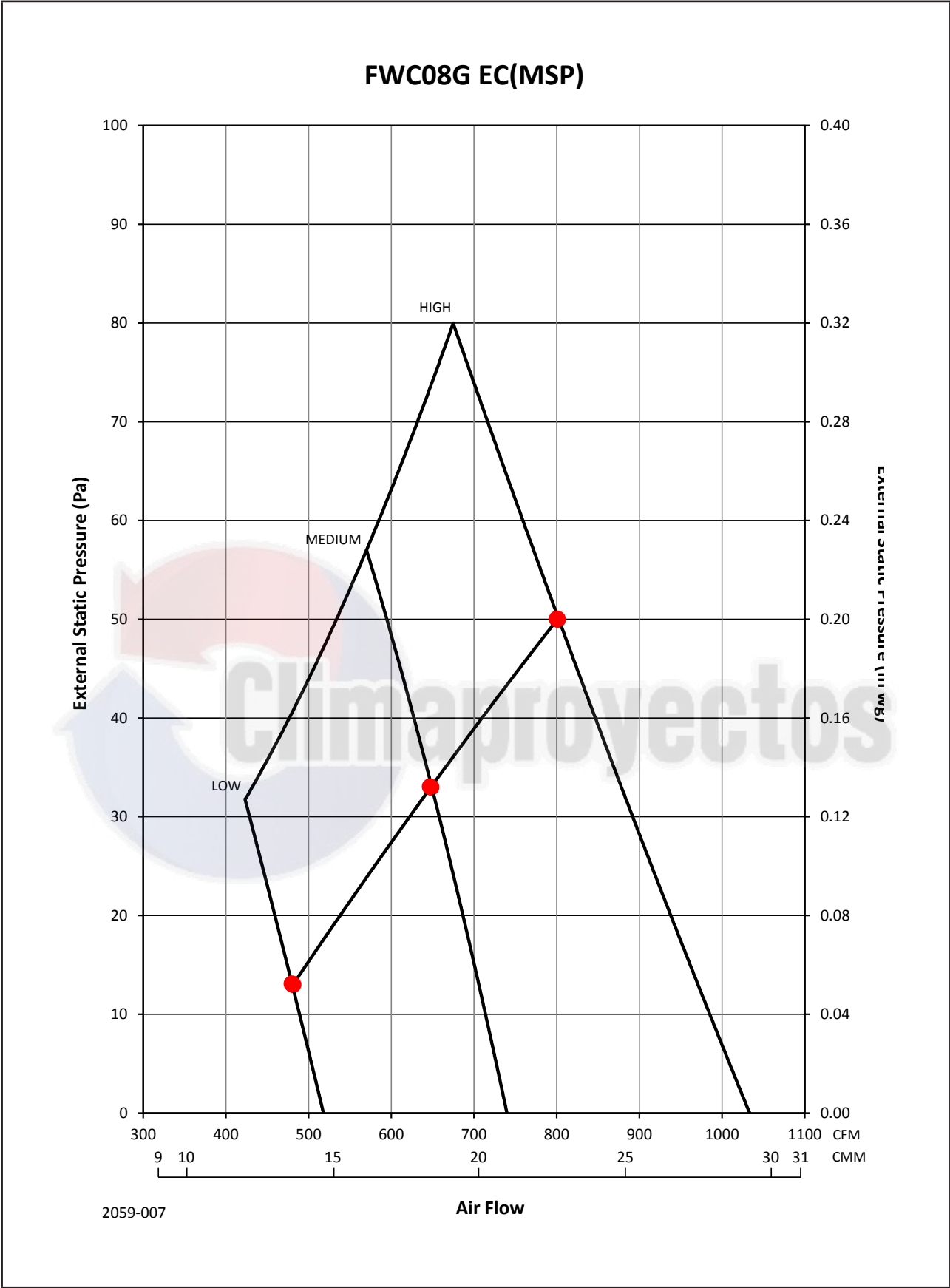

2059-007

Air Flow

### FWC10G EC(MSP)

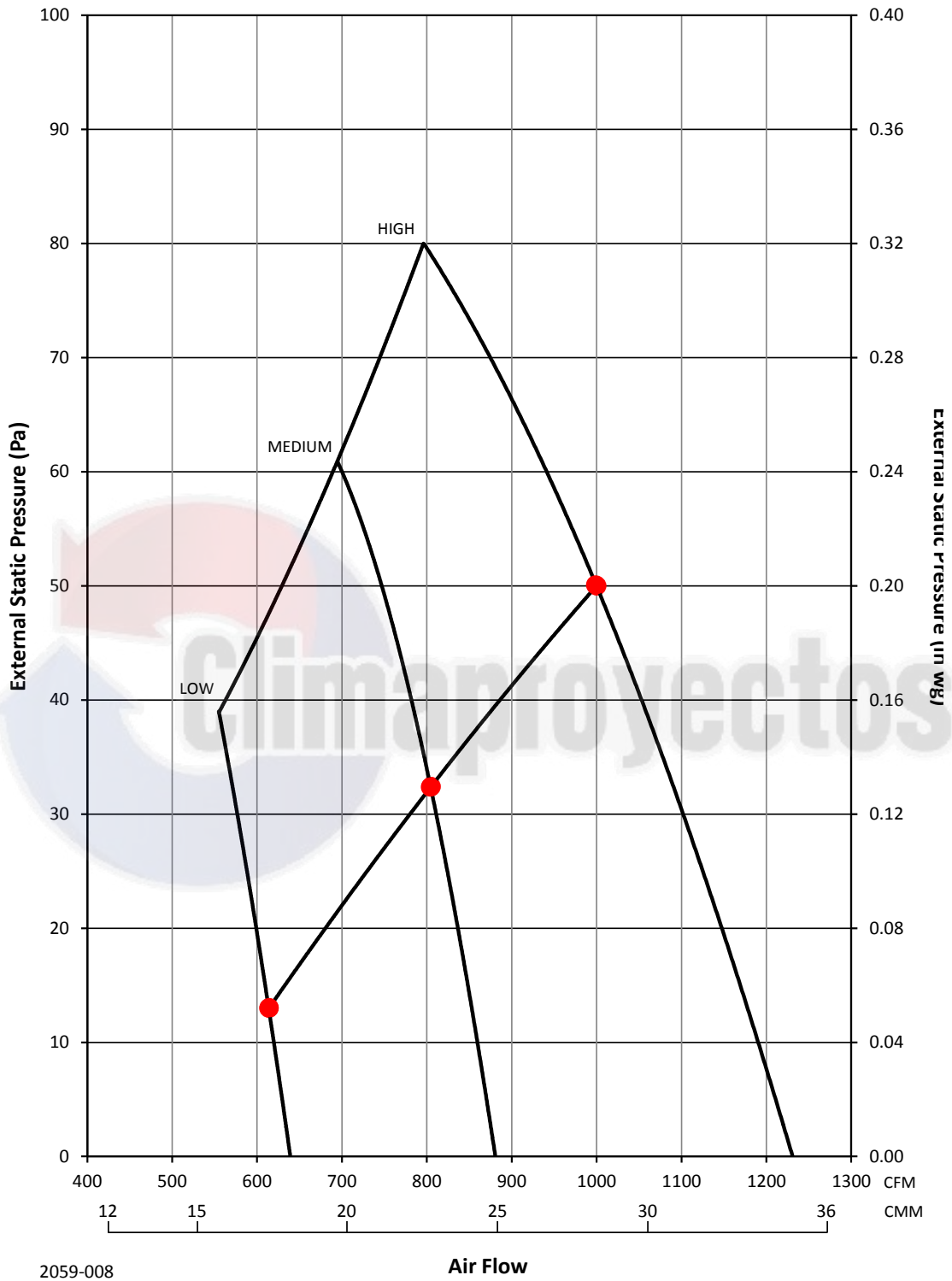

2059-008

### FWC12G EC(MSP)

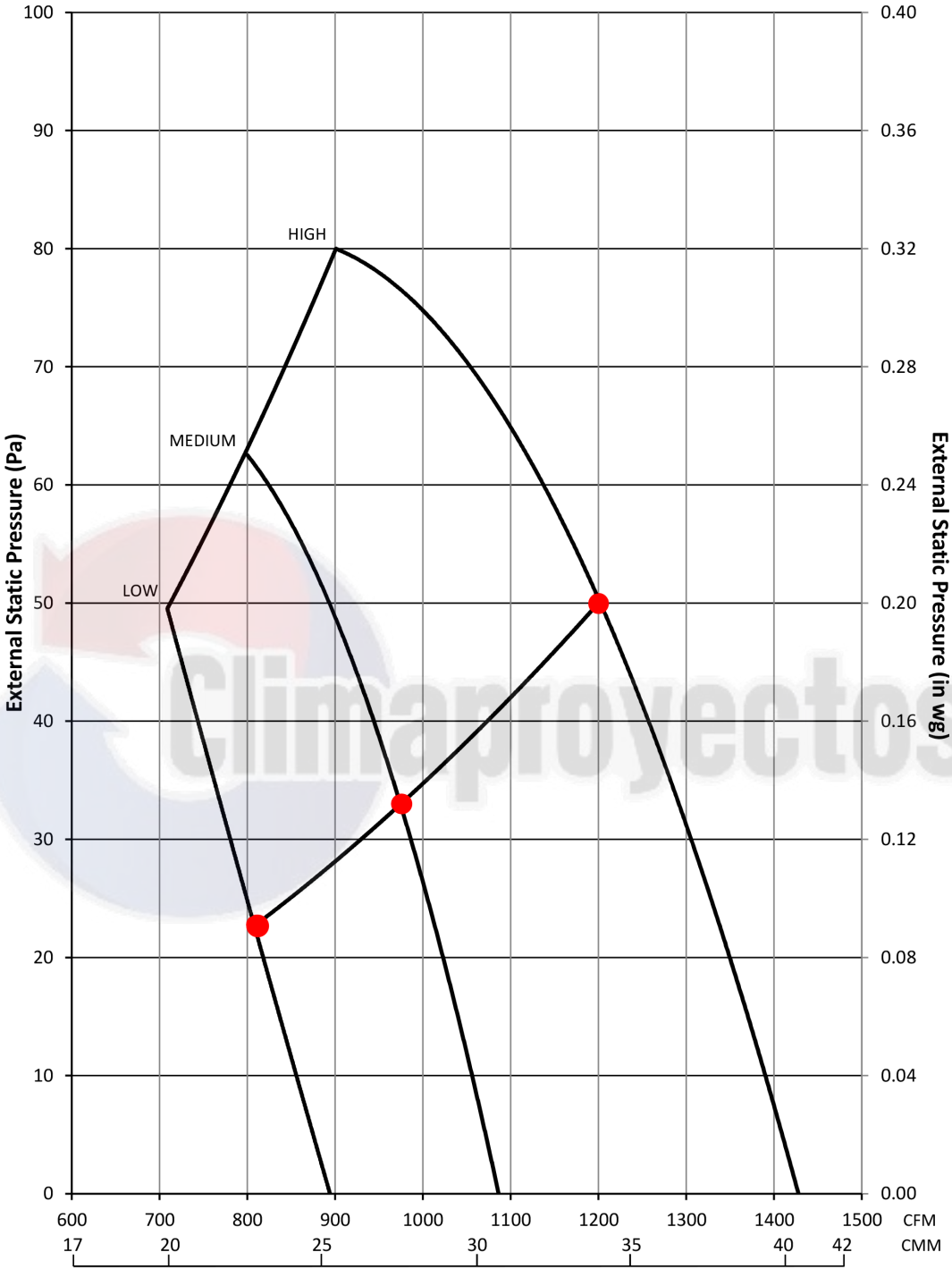

2059-009

Air Flow



### FUD20B

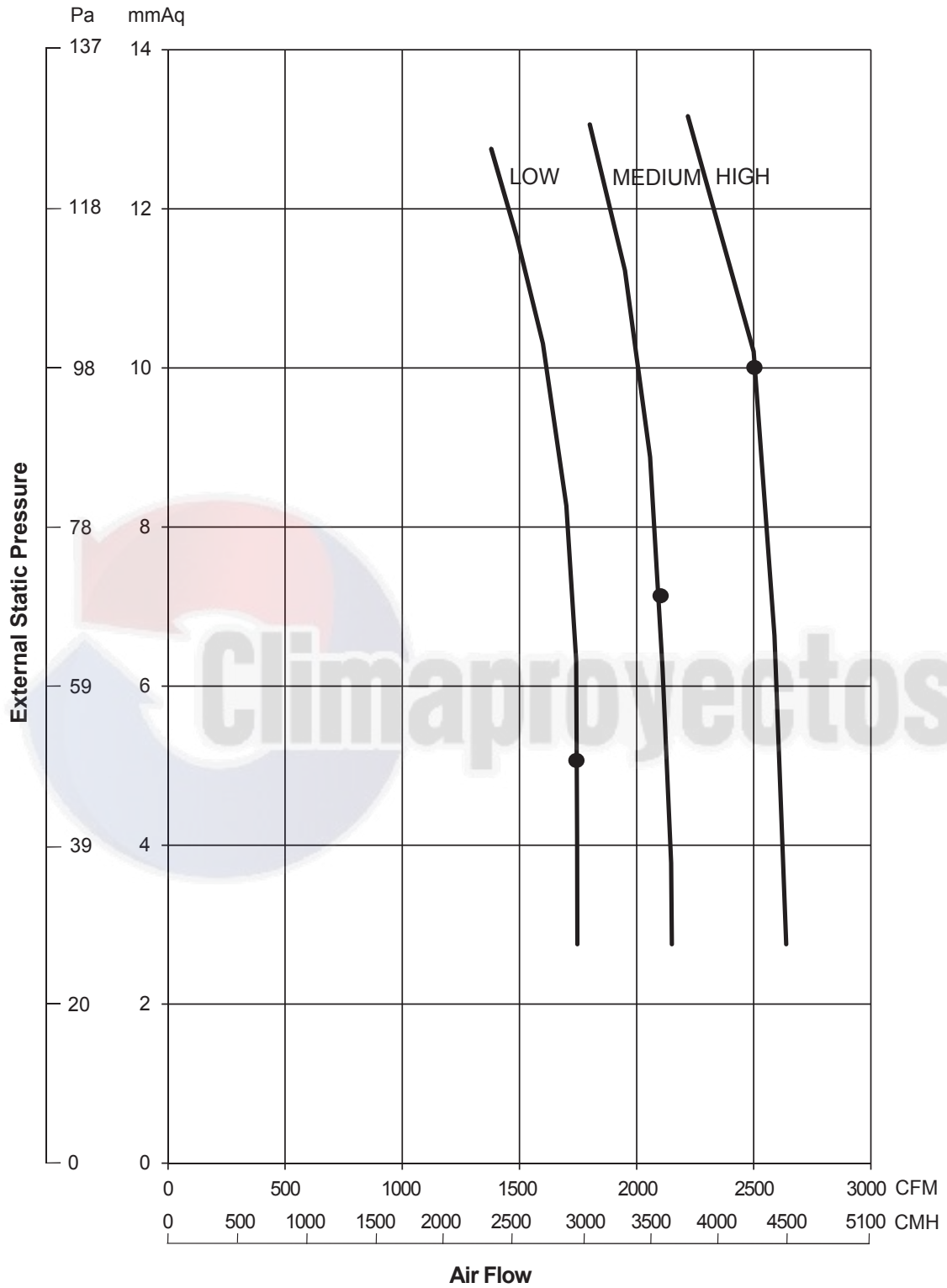

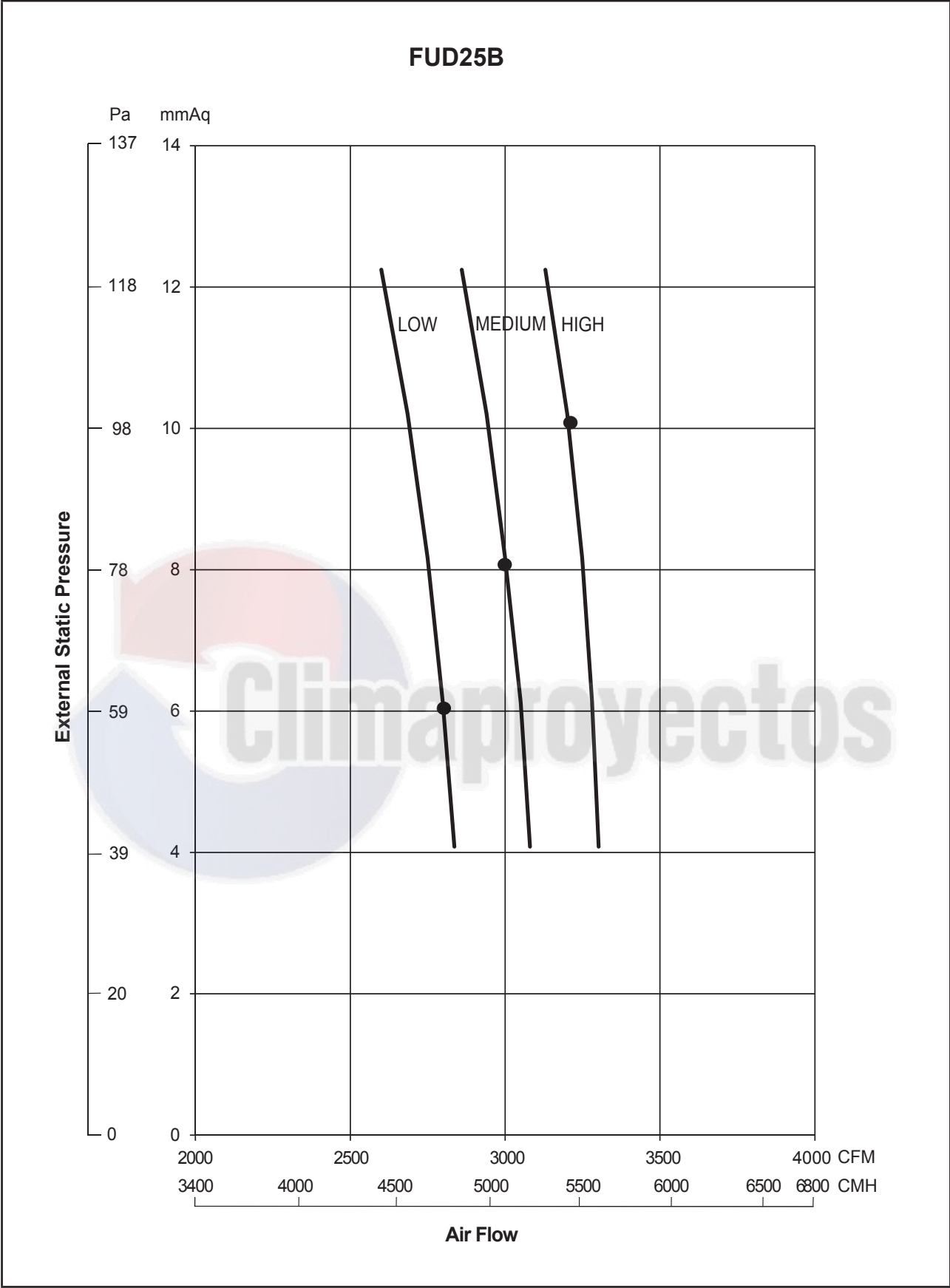

### FUD30B

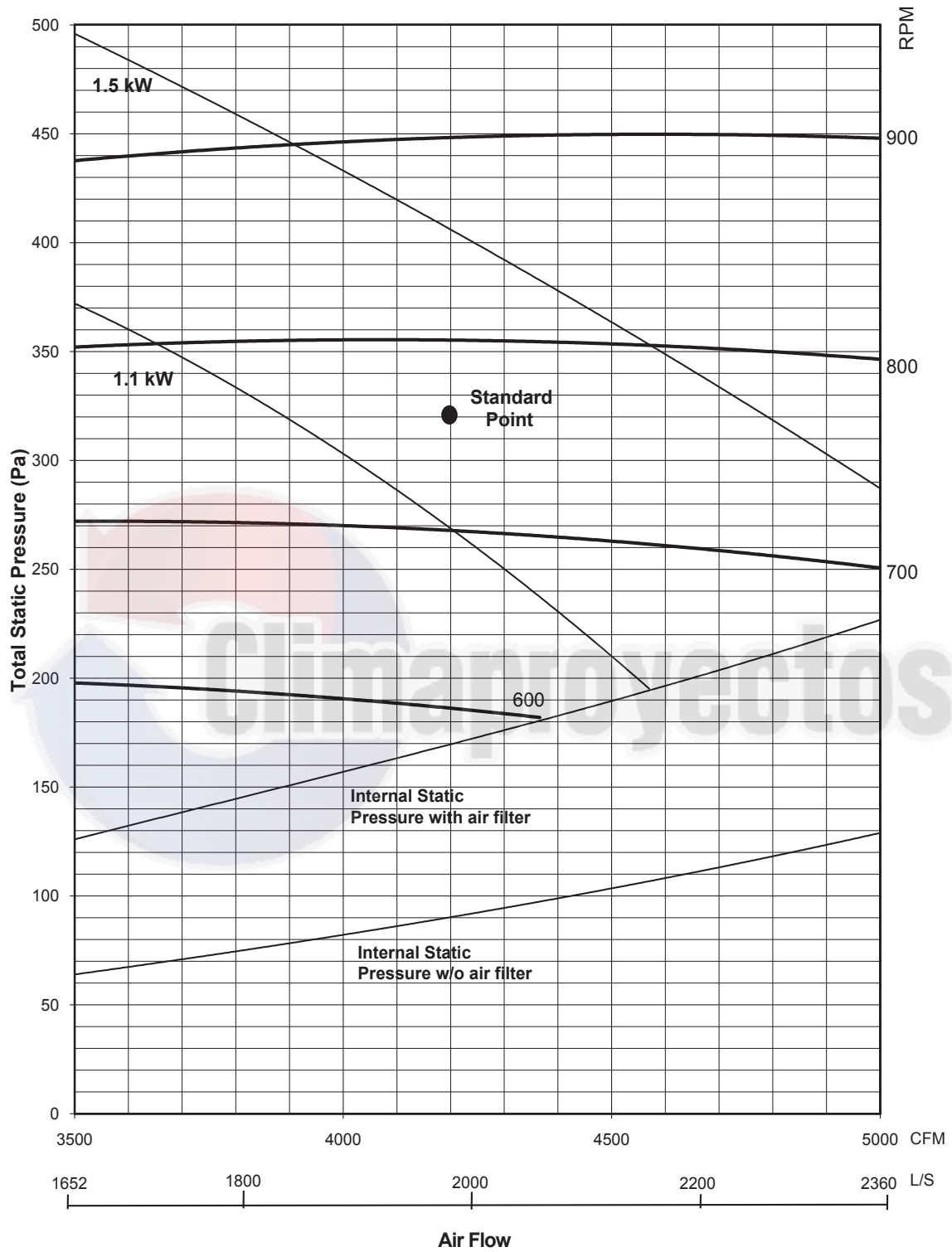

# Engineering & Physical Data

## Engineering Data - Chilled Water Fan Coil Unit

MODEL				FWW03L	FWW04L	FWW05L	FWW06L					
NOMINAL COOLING CAPACITY				Btu/h	9200	11300	15500	18000				
				W	2700	3310	4540	5280				
NOMINAL SENSIBLE COOLING CAPACITY				Btu/h	6900	9000	11700	14000				
				W	2020	2640	3430	4100				
NOMINAL HEATING CAPACITY (ENTERING WATER TEMP. = 50°C)				Btu/h	12800	14000	20500	23000				
				W	3750	4100	6010	6740				
NOMINAL TOTAL INPUT POWER				W	31	42	57	70				
NOMINAL RUNNING CURRENT				A	0.18	0.20	0.30	0.33				
POWER SOURCE				V/Ph/Hz	208-230 / 1 / 60							
INDOOR UNIT	CONTROL			AUTOMATIC LOUVER ( UP & DOWN)								
	OPERATION			LCD WIRELESS MICRO-COMPUTER REMOTE CONTROL								
	AIR FLOW			HIGH	CFM	280	370	510	620			
				MEDIUM	CFM	250	320	450	520			
				LOW	CFM	220	260	390	460			
				QUIET	CFM	190	240	360	440			
	NOMINAL WATER FLOW RATE			USGPM	2.03	2.51	3.43	4.01				
				litres/min	7.68	9.50	13.00	15.18				
	HEAD LOSS (COOLING)			kPa	24.0	31.0	30.0	36.0				
	HEAD LOSS (HEATING) : 50°C			kPa	20.0	25.0	27.0	33.0				
	MAX. WORKING PRESSURE			kPa	1608							
	SURFACE AIR VELOCITY			m/s	0.74	0.97	0.83	1.01				
	SOUND PRESSURE LEVEL (H/M/L)			dBA	35 / 30 / 25 / 24	42 / 39 / 32 / 29	42 / 38 / 34 / 32	46 / 42 / 39 / 37				
	UNIT DIMENSION		H X W X D	mm	288 X 800 X 206			310 X 1065 X 224				
	PACKING DIMENSION		H X W X D	mm	344 X 874 X 274			386 X 1136 X 314				
	UNIT WEIGHT			kg	9			14				
	CONDENSATE DRAIN SIZE			mm	19.05							
	PIPE CONNECTION			mm	12.70 BSP FEMALE THREAD ADAPTOR							
	FAN			TYPE					CROSS FLOW FAN			
				DRIVE					DIRECT			
				FAN SPEED			HIGH	RPM	1050	1310	1035	1150
							MEDIUM	RPM	910	1150	920	1070
	LOW	RPM	780				955	825	970			
	FAN MOTOR			TYPE					SINGLE PHASE SCR			
				INDEX OF PROTECTION (IP)					IP44			
				INSULATION GRADE					E			
RATED INPUT POWER				HIGH	W	31	42	57	70			
				MEDIUM	W	26	34	46	61			
				LOW	W	20	26	38	51			
RATED RUNNING CURRENT				HIGH	A	0.18	0.20	0.30	0.33			
				MEDIUM	A	0.16	0.19	0.27	0.31			
				LOW	A	0.15	0.16	0.25	0.29			
STARTING CURRENT				A	0.225	0.225	0.356	0.356				
MOTOR OUTPUT			W	18	18	30	30					
POLES			4									
COIL			TUBE MATERIAL					COPPER				
			DIAMETER			mm	7.00					
			FIN MATERIAL					ALUMINIUM				
			FACE AREA			m <sup>2</sup>	0.18	0.18	0.29	0.29		
			ROW			2						
WATER VOLUME			litre	0.58	0.58	0.95	0.95					
AIR QUALITY FILTER			TYPE					WASHABLE SARANET FILTER				
			QUANTITY			pc	2					
CASING			COLOUR	WHITE								

MODE	COOLING	HEATING
ENTERING AIR TEMPERATURE	27°C DB / 19°C WB	20°C DB
ENTERING WATER TEMPERATURE	7°C	50°C (2 Pipes System) 70°C (4 Pipes System)
LEAVING WATER TEMPERATURE	12°C	60°C (4 Pipes System)

ALL SPECIFICATIONS ARE SUBJECTED TO CHANGE BY THE MANUFACTURER WITHOUT PRIOR NOTICE.

## Engineering Data - Chilled Water Fan Coil Unit

MODEL		FWKE05E				FWKE08E					
		HIGH	MEDIUM	LOW	QUIET	HIGH	MEDIUM	LOW	QUIET		
NOMINAL COOLING CAPACITY	Btu/h	20100	15900	11900	8200	30000	24700	19800	15200		
	W	5900	4650	3500	2400	8800	7250	5800	4550		
NOMINAL SENSIBLE COOLING CAPACITY	Btu/h	15400	11700	8700	5800	21900	18500	14500	11000		
	W	4510	3440	2540	1710	6430	5410	4260	3220		
NOMINAL HEATING CAPACITY (ENTERING WATER TEMP. = 50°C)	Btu/h	24200	19800	15200	11300	38200	30400	23900	18400		
	W	7100	5800	4450	3300	11200	8900	7000	5400		
NOMINAL TOTAL INPUT POWER	W	37	19	12	7	90	50	26	17		
NOMINAL RUNNING CURRENT	A	0.47	0.28	0.20	0.14	0.97	0.61	0.36	0.26		
POWER SOURCE	V/Ph/Hz	208-230 / 1 / 60									
INDOOR UNIT	CONTROL		AIR DISCHARGE OPERATION		4 WAY AUTOMATIC LOUVER ( UP & DOWN) LCD WIRELESS MICRO-COMPUTER REMOTE CONTROL						
	AIR FLOW		CFM	620	470	350	220	890	720	560	420
	NOMINAL WATER FLOW RATE		USGPM	4.52	3.56	2.68	1.84	6.74	5.55	4.44	3.41
			litres/min	17.10	13.48	10.15	6.96	25.51	21.02	16.81	12.90
	HEAD LOSS (COOLING)		kPa	24	15	10	5	20	14	9	7
	HEAD LOSS (HEATING) : 50°C		kPa	21	13	8	4	18	12	8	5
	MAX. WORKING PRESSURE		kPa	1608							
	SURFACE AIR VELOCITY		m/s	0.64	0.60	0.42	0.27	0.81	0.68	0.55	0.43
	SOUND PRESSURE LEVEL		dBA	37	31	23	16	47	42	37	31
	UNIT DIMENSION - (WITH PANEL)		H X W X D	288 X 820 X 820 (340 X 990 X 990)							
	PACKING DIMENSION - (PANEL)		H X W X D	341 X 916 X 916 (125 X 1020 X 1020)							
	UNIT WEIGHT (UNIT + PANEL)		kg	26 + 4				28 + 4			
	CONDENSATE DRAIN SIZE		mm	19.05							
	PIPE CONNECTION		mm	19.05 BSP FEMALE THREAD ADAPTOR							
	FAN	TYPE		TURBO FAN							
		DRIVE		DIRECT							
		FAN SPEED		RPM	450	360	280	200	660	550	440
	FAN MOTOR	TYPE		BRUSHLESS DIRECT CURRENT							
		INDEX OF PROTECTION (IP)		IP20							
		INSULATION GRADE		E							
RATED INPUT POWER		W	37	19	12	7	90	50	26	17	
RATED RUNNING CURRENT		A	0.47	0.28	0.20	0.14	0.97	0.61	0.36	0.26	
STARTING CURRENT		A	1.5				2.2				
MOTOR OUTPUT		W	70				70				
COIL	POLES		8								
	TUBE	MATERIAL	COPPER								
		DIAMETER	mm	7.00							
	FIN	MATERIAL	ALUMINIUM								
		FACE AREA	m <sup>2</sup>	0.39				0.37			
WATER VOLUME		litre	2				3				
AIR QUALITY	FILTER	TYPE	WASHABLE SARANET FILTER								
		QUANTITY	pc	1							
CASING		COLOUR	LIGHT GREY								

NOTE:  
 A) BASED ON EUROVENT CONDITIONS  
 B) ADDITIONAL 10W IS REQUIRED FOR CONDENSATE DRAIN PUMP  
 C) SOUND PRESSURE LEVEL IS TESTED AS PER JIS STANDARD AS BELOW:  
 FWKE05E(H) MODEL - 1.4M BELOW THE FACE CENTER OF AIR RETURN OF THE UNIT  
 FWKE08/11E(H) MODEL - 1.5M BELOW THE FACE CENTER OF AIR RETURN OF THE UNIT

MODE	COOLING	HEATING
ENTERING AIR TEMPERATURE	27°C DB / 19°C WB	20°C DB
ENTERING WATER TEMPERATURE	7°C	50°C (2 Pipes System) 70°C (4 Pipes System)
LEAVING WATER TEMPERATURE	12°C	60°C (4 Pipes System)

ALL SPECIFICATIONS ARE SUBJECTED TO CHANGE BY THE MANUFACTURER WITHOUT PRIOR NOTICE.

## Engineering Data - Chilled Water Fan Coil Unit

MODEL		FWKE11E				
		HIGH	MEDIUM	LOW	QUIET	
NOMINAL COOLING CAPACITY	Btu/h	40100	33100	26800	21000	
	W	11750	9700	7850	6150	
NOMINAL SENSIBLE COOLING CAPACITY	Btu/h	28600	23800	18900	14600	
	W	8370	6970	5540	4270	
NOMINAL HEATING CAPACITY (ENTERING WATER TEMP. = 50°C)	Btu/h	46700	39100	31600	24100	
	W	13700	11450	9250	7050	
NOMINAL TOTAL INPUT POWER	W	120	83	39	23	
NOMINAL RUNNING CURRENT	A	1.23	0.92	0.49	0.32	
POWER SOURCE	V/Ph/Hz	208-230 / 1 / 60				
INDOOR UNIT	CONTROL	AIR DISCHARGE OPERATION	4 WAY AUTOMATIC LOUVER ( UP & DOWN) LCD WIRELESS MICRO-COMPUTER REMOTE CONTROL			
	AIR FLOW	CFM	1060	870	680	510
	NOMINAL WATER FLOW RATE	USGPM	9.00	7.43	6.01	4.71
		litres/min	34.06	28.12	22.76	17.83
	HEAD LOSS (COOLING)	kPa	41	30	22	15
	HEAD LOSS (HEATING) : 50°C	kPa	37	26	20	12
	MAX. WORKING PRESSURE	kPa	1608			
	SURFACE AIR VELOCITY	m/s	0.83	0.71	0.57	0.45
	SOUND PRESSURE LEVEL	dBA	51	46	41	34
	UNIT DIMENSION - (WITH PANEL)	H X W X D	300 X 820 X 820 ( 375 X 990 X 990)			
	PACKING DIMENSION - (PANEL)	H X W X D	376 X 916 X 916 ( 125 X 1020 X 1020)			
	UNIT WEIGHT (UNIT + PANEL)	kg	32 + 4			
	CONDENSATE DRAIN SIZE	mm	19.05			
	PIPE CONNECTION	mm	19.05 BSP FEMALE THREAD ADAPTOR			
	FAN	TYPE	TURBO FAN			
		DRIVE	DIRECT			
	FAN SPEED	RPM	750	630	510	400
	FAN MOTOR	TYPE	BRUSHLESS DIRECT CURRENT			
		INDEX OF PROTECTION (IP)	IP20			
		INSULATION GRADE	E			
RATED INPUT POWER		W	120	83	39	23
RATED RUNNING CURRENT		A	1.23	0.92	0.49	0.32
STARTING CURRENT		A	2.2			
MOTOR OUTPUT		W	100			
POLES		8				
COIL	TUBE	MATERIAL	COPPER			
		DIAMETER	7.00			
	FIN	MATERIAL	ALUMINIUM			
		FACE AREA	0.46			
		ROW	3			
WATER VOLUME	litre	2.35				
AIR QUALITY	FILTER	TYPE	WASHABLE SARANET FILTER			
		QUANTITY	1			
CASING	COLOUR	LIGHT GREY				

## NOTE:

- A) BASED ON EUROVENT CONDITIONS  
 B) ADDITIONAL 10W IS REQUIRED FOR CONDENSATE DRAIN PUMP  
 C) SOUND PRESSURE LEVEL IS TESTED AS PER JIS STANDARD AS BELOW:  
 FWKE05E(H) MODEL - 1.4M BELOW THE FACE CENTER OF AIR RETURN OF THE UNIT  
 FWKE08/11E(H) MODEL - 1.5M BELOW THE FACE CENTER OF AIR RETURN OF THE UNIT

MODE	COOLING	HEATING
ENTERING AIR TEMPERATURE	27°C DB / 19°C WB	20°C DB
ENTERING WATER TEMPERATURE	7°C	50°C (2 Pipes System) 70°C (4 Pipes System)
LEAVING WATER TEMPERATURE	12°C	60°C (4 Pipes System)

ALL SPECIFICATIONS ARE SUBJECTED TO CHANGE BY THE MANUFACTURER WITHOUT PRIOR NOTICE.

### Engineering Data - Chilled Water Fan Coil Unit

MODEL			FWKE05EH				FWKE08EH				
			HIGH	MEDIUM	LOW	QUIET	HIGH	MEDIUM	LOW	QUIET	
NOMINAL COOLING CAPACITY	Btu/h		15000	12300	9600	6800	24600	20800	17100	13300	
	W		4400	3600	2800	2000	7200	6100	5000	3900	
NOMINAL SENSIBLE COOLING CAPACITY	Btu/h		13100	10200	7600	5300	19600	16600	13000	9900	
	W		3850	2990	2240	1560	5750	4850	3810	2910	
NOMINAL HEATING CAPACITY (ENTERING WATER TEMP. = 70°C)	Btu/h		26100	21700	17200	12800	38200	32800	27300	21800	
	W		7650	6350	5050	3750	11200	9600	8000	6400	
NOMINAL TOTAL INPUT POWER	W		37	19	12	7	90	50	26	17	
NOMINAL RUNNING CURRENT	A		0.47	0.28	0.20	0.14	0.97	0.61	0.36	0.26	
POWER SOURCE	V/Ph/Hz		208-230/1/60								
INDOOR UNIT	CONTROL	AIR DISCHARGE OPERATION	4 WAY AUTOMATIC LOUVER (UP & DOWN) LCD WIRELESS MICRO-COMPUTER REMOTE CONTROL								
	AIR FLOW	CFM	620	470	350	220	890	720	560	420	
	NOMINAL WATER FLOW RATE (COOLING)	USGPM		3.37	2.76	2.14	1.53	5.51	4.67	3.83	2.99
		litres/min		12.75	10.44	8.12	5.80	20.87	17.68	14.49	11.31
	NOMINAL WATER FLOW RATE (HEATING)	USGPM		2.93	2.43	1.93	1.44	4.29	3.68	3.06	2.45
		litres/min		11.09	9.20	7.31	5.50	16.23	13.91	11.67	9.28
	HEAD LOSS (COOLING)	kPa		18	13	9	5	19	15	10	6
	HEAD LOSS (HEATING) : 70°C	kPa		22	17	10	7	32	25	18	13
	MAX. WORKING PRESSURE	kPa		1608							
	SURFACE AIR VELOCITY	m/s		0.64	0.60	0.42	0.27	0.81	0.68	0.55	0.43
	SOUND PRESSURE LEVEL	dBA		37	31	23	16	47	42	37	31
	UNIT DIMENSION - (WITH PANEL)	H X W X D	mm	265X 820 X 820 (340 X 990 X 990)							
	PACKING DIMENSION - (PANEL)	H X W X D	mm	341 X 916 X 916 (125 X 1020 X 1020)							
	UNIT WEIGHT (UNIT + PANEL)	kg		26 + 4			28 + 4				
	CONDENSATE DRAIN SIZE	mm		19.05							
	PIPE CONNECTION	mm		19.05 BSP FEMALE THREAD ADAPTOR							
	FAN	TYPE		TURBO FAN							
		DRIVE		DIRECT							
		FAN SPEED	RPM	450	360	280	200	660	550	440	350
	FAN MOTOR	TYPE		BRUSHLESS DIRECT CURRENT							
		INDEX OF PROTECTION (IP)		IP20							
		INSULATION GRADE		E							
		RATED INPUT POWER	W	37	19	12	7	90	50	26	17
		RATED RUNNING CURRENT	A	0.47	0.28	0.20	0.14	0.97	0.61	0.36	0.26
		STARTING CURRENT	A	1.5			2.2				
		MOTOR OUTPUT	W	70			70				
POLES		8									
COIL	TUBE	MATERIAL	COPPER								
		DIAMETER	mm	7.00							
	FIN	MATERIAL	ALUMINIUM								
		FACE AREA	m <sup>2</sup>	0.39			0.37				
	ROW		2			3					
WATER VOLUME	litre	1.36			1.97						
AIR QUALITY	FILTER	TYPE	WASHABLE SARANET FILTER								
		QUANTITY	pc	1							
CASING	COLOUR		LIGHT GREY								

NOTE:  
 A) BASED ON EUROVENT CONDITIONS  
 B) ADDITIONAL 10W IS REQUIRED FOR CONDENSATE DRAIN PUMP  
 C) SOUND PRESSURE LEVEL IS TESTED AS PER JIS STANDARD AS BELOW:  
 FWKE05E(H) MODEL - 1.4M BELOW THE FACE CENTER OF AIR RETURN OF THE UNIT  
 FWKE08/11E(H) MODEL - 1.5M BELOW THE FACE CENTER OF AIR RETURN OF THE UNIT

MODE	COOLING	HEATING
ENTERING AIR TEMPERATURE	27°C DB / 19°C WB	20°C DB
ENTERING WATER TEMPERATURE	7°C	50°C (2 Pipes System) 70°C (4 Pipes System)
LEAVING WATER TEMPERATURE	12°C	60°C (4 Pipes System)

ALL SPECIFICATIONS ARE SUBJECTED TO CHANGE BY THE MANUFACTURER WITHOUT PRIOR NOTICE.

## Engineering Data - Chilled Water Fan Coil Unit

MODEL		FWKE11EH					
		HIGH	MEDIUM	LOW	QUIET		
NOMINAL COOLING CAPACITY	Btu/h	30700	26400	22200	17700		
	W	9000	7750	6500	5200		
NOMINAL SENSIBLE COOLING CAPACITY	Btu/h	24500	20700	16700	13300		
	W	7170	6060	4900	3890		
NOMINAL HEATING CAPACITY (ENTERING WATER TEMP. = 70°C)	Btu/h	53400	46200	39100	31900		
	W	15650	13550	11450	9350		
OMINAL TOTAL INPUT POWER	W	120	83	39	23		
NOMINAL RUNNING CURRENT	A	1.23	0.92	0.49	0.32		
POWER SOURCE	V/Ph/Hz	208-230 / 1 / 60					
INDOOR UNIT	CONTROL	AIR DISCHARGE OPERATION	4 WAY AUTOMATIC LOUVER (UP & DOWN) LCD WIRELESS MICRO-COMPUTER REMOTE CONTROL				
	AIR FLOW	CFM	1060	870	680	510	
	NOMINAL WATER FLOW RATE (COOLING)	USGPM	6.89	5.93	4.98	3.98	
		litres/min	26.09	22.47	18.84	15.07	
	NOMINAL WATER FLOW RATE (HEATING)	USGPM	5.99	5.19	4.38	3.58	
		litres/min	22.68	19.64	16.60	13.55	
	HEAD LOSS (COOLING)	kPa	32	24	19	12	
	HEAD LOSS (HEATING) : 50°C	kPa	52	39	30	21	
	MAX. WORKING PRESSURE	kPa	1608				
	SURFACE AIR VELOCITY	m/s	0.83	0.71	0.57	0.45	
	SOUND PRESSURE LEVEL	dBA	51	46	41	34	
	UNIT DIMENSION - (WITH PANEL)	H X W X D	300 X 820 X 820 ( 375 X 990 X 990)				
	PACKING DIMENSION - (PANEL)	H X W X D	376 X 916 X 916 ( 125 X 1020 X 1020)				
	UNIT WEIGHT (UNIT + PANEL)	kg	32 + 4				
	CONDENSATE DRAIN SIZE	mm	19.05				
	PIPE CONNECTION	mm	19.05 BSP FEMALE THREAD ADAPTOR				
	FAN	TYPE	TURBO FAN				
		DRIVE	DIRECT				
	FAN SPEED	RPM	750	630	510	400	
	FAN MOTOR	TYPE	BRUSHLESS DIRECT CURRENT				
INDEX OF PROTECTION (IP)		IP20					
INSULATION GRADE		E					
RATED INPUT POWER		W	120	83	39	23	
RATED RUNNING CURRENT		A	1.23	0.92	0.49	0.32	
STARTING CURRENT		A	2.2				
MOTOR OUTPUT		W	100				
POLES		8					
COIL	TUBE	MATERIAL	COPPER				
		DIAMETER	mm	7.00			
	FIN	MATERIAL	ALUMINIUM				
		FACE AREA	m <sup>2</sup>	0.46			
		ROW		3			
WATER VOLUME	litre	2.35					
AIR QUALITY	FILTER	TYPE	WASHABLE SARANET FILTER				
		QUANTITY	pc	1			
CASING	COLOUR	LIGHT GREY					

## NOTE:

A) BASED ON EUROVENT CONDITIONS

B) ADDITIONAL 10W IS REQUIRED FOR CONDENSATE DRAIN PUMP

C) SOUND PRESSURE LEVEL IS TESTED AS PER JIS STANDARD AS BELOW:

FWKE05E(H) MODEL - 1.4M BELOW THE FACE CENTER OF AIR RETURN OF THE UNIT

FWKE08/11E(H) MODEL - 1.5M BELOW THE FACE CENTER OF AIR RETURN OF THE UNIT

MODE	COOLING	HEATING
ENTERING AIR TEMPERATURE	27°C DB / 19°C WB	20°C DB
ENTERING WATER TEMPERATURE	7°C	50°C (2 Pipes System)
		70°C (4 Pipes System)
LEAVING WATER TEMPERATURE	12°C	60°C (4 Pipes System)

ALL SPECIFICATIONS ARE SUBJECTED TO CHANGE BY THE MANUFACTURER WITHOUT PRIOR NOTICE.



## Engineering Data - Chilled Water Fan Coil Unit

MODEL				FWC03C	FWC04C	FWC06C	FWC07C					
NOMINAL COOLING CAPACITY				Btu/h	9900	11600	18000	22500				
				W	2900	3400	5280	6590				
NOMINAL SENSIBLE COOLING CAPACITY				Btu/h	7000	8120	12600	15750				
				W	2050	2380	3690	4620				
NOMINAL HEATING CAPACITY (ENTERING WATER TEMP. = 50°C)				Btu/h	11500	15000	23000	29000				
				W	3370	4400	6740	8500				
NOMINAL TOTAL INPUT POWER				W	77	128	170	215				
NOMINAL RUNNING CURRENT				A	0.35	0.58	0.79	0.98				
POWER SOURCE				V/Ph/Hz	208-230 / 1 / 60							
INDOOR UNIT	CONTROL			DUCTED								
	AIR DISCHARGE OPERATION			WIRED MICRO-COMPUTER REMOTE CONTROL								
	AIR FLOW			HIGH	CFM	300	510	700	730			
				MEDIUM	CFM	265	440	650	640			
				LOW	CFM	220	360	490	550			
	EXTERNAL STATIC PRESSURE			Pa	20 / 16 / 11	29 / 22 / 15	39 / 34 / 20	83 / 64 / 47				
	NOMINAL WATER FLOW RATE			USGPM	2.20	2.60	4.05	5.06				
				litres/min	8.33	9.84	15.33	19.15				
	HEAD LOSS (COOLING)			kPa	10.5	24.0	20.1	32.4				
	HEAD LOSS (HEATING) : 50°C			kPa	8.8	20.3	17.0	27.6				
	MAX. WORKING PRESSURE			kPa	1608							
	SURFACE AIR VELOCITY			m/s	1.29	1.72	1.83	1.72				
	SOUND PRESSURE LEVEL (H/M/L)			dBa	36 / 33 / 29	40 / 36 / 31	42 / 41 / 35	41 / 39 / 36				
	UNIT DIMENSION		H X W X D	mm	267 X 702 X 351	267 X 842 X 351	267 X 1002 X 351	267 X 1137 X 351				
	PACKING DIMENSION		H X W X D	mm	376 X 951 X 541	376 X 1091 X 541	376 X 1251 X 541	376 X 1386 X 541				
	UNIT WEIGHT			kg	18	22	24	26				
	CONDENSATE DRAIN SIZE			mm	19.05							
	PIPE CONNECTION			mm	19.05 BSP FEMALE THREAD ADAPTOR							
	FAN			BLOWER								
				DRIVE					DIRECT			
				FAN SPEED			HIGH	RPM	1100	1320	1360	1520
							MEDIUM	RPM	950	1150	1250	1350
	LOW	RPM	800				940	980	1180			
	FAN MOTOR			PERMANENT SPLIT CAPACITOR (INDUCTION)								
				INDEX OF PROTECTION (IP)			IP20					
				INSULATION GRADE			E					
				RATED INPUT POWER			HIGH	W	77	128	170	215
							MEDIUM	W	62	104	155	166
							LOW	W	44	75	110	138
				RATED RUNNING CURRENT			HIGH	A	0.35	0.58	0.79	0.98
MEDIUM							A	0.28	0.48	0.72	0.76	
LOW							A	0.20	0.35	0.53	0.64	
STARTING CURRENT				A	0.40	0.81	1.13	1.53				
MOTOR OUTPUT			W	30	50	80	100					
POLES			4									
COIL			COPPER									
			TUBE		DIAMETER					mm	9.52	
			FIN		MATERIAL					ALUMINIUM		
					FACE AREA		m <sup>2</sup>	0.11	0.14	0.18	0.20	
					ROW		3					
WATER VOLUME			litre	0.94	1.15	1.43	1.63					
AIR QUALITY CASING			FILTER		TYPE			WASHABLE SARANET FILTER				
			QUANTITY		pc	1						
			COLOUR		WITHOUT PAINT							

MODE	COOLING	HEATING
ENTERING AIR TEMPERATURE	27°C DB / 19°C WB	20°C DB
ENTERING WATER TEMPERATURE	7°C	50°C (2 Pipes System) 70°C (4 Pipes System)
LEAVING WATER TEMPERATURE	12°C	60°C (4 Pipes System)

ALL SPECIFICATIONS ARE SUBJECTED TO CHANGE BY THE MANUFACTURER WITHOUT PRIOR NOTICE.

## Engineering Data - Chilled Water Fan Coil Unit

MODEL				FWC09C	FWC12C	FWC14C	FWC16C									
NOMINAL COOLING CAPACITY				Btu/h	24800	37000	44700	51800								
				W	7270	10840	13100	15180								
NOMINAL SENSIBLE COOLING CAPACITY				Btu/h	19700	29300	35100	40900								
				W	5770	8590	10290	11990								
NOMINAL HEATING CAPACITY (ENTERING WATER TEMP. = 50°C)				Btu/h	32800	48000	54900	65300								
				W	9610	14070	16090	19140								
NOMINAL TOTAL INPUT POWER				W	592	618	684	780								
NOMINAL RUNNING CURRENT				A	2.70	2.80	3.12	3.55								
POWER SOURCE				V/Ph/Hz	208-230 / 1 / 60											
INDOOR UNIT	CONTROL			DUCTED												
	AIR DISCHARGE OPERATION			WIRED MICRO-COMPUTER REMOTE CONTROL												
	AIR FLOW			CFM	830	1240	1340	1550								
				MEDIUM	CFM	750	1060	1220	1460							
				LOW	CFM	660	930	1100	1340							
	EXTERNAL STATIC PRESSURE				Pa	167 / 137 / 108	152 / 111 / 85	186 / 155 / 126	196 / 174 / 147							
	NOMINAL WATER FLOW RATE				USGPM	5.55	8.28	10.04	11.62							
					litres/min	21.01	31.34	38.00	43.98							
	HEAD LOSS (COOLING)				kPa	14.0	23.0	38.0	51.0							
	HEAD LOSS (HEATING) : 50°C				kPa	11.0	19.0	33.0	48.0							
	MAX. WORKING PRESSURE				kPa	1608										
	SURFACE AIR VELOCITY				m/s	1.40	1.83	1.54	1.52							
	SOUND PRESSURE LEVEL (H/M/L)				dBA	46 / 42 / 35	49 / 44 / 39	52 / 49 / 46	53 / 51 / 48							
	UNIT DIMENSION		H X W X D		mm	384 X 917 X 462	384 X 1003 X 462	384 X 1287 X 462	384 X 1487 X 462							
	PACKING DIMENSION		H X W X D		mm	415 X 1126 X 631	415 X 1245 X 631	415 X 1497 X 631	415 X 1701 X 631							
	UNIT WEIGHT				kg	42	44	50	56							
	CONDENSATE DRAIN SIZE				mm	19.05										
	PIPE CONNECTION				mm	19.05 BSP FEMALE THREAD ADAPTOR										
	FAN				BLOWER											
					TYPE				DIRECT							
					DRIVE				DIRECT							
					FAN SPEED				HIGH	RPM	1240	1320	1390	1460		
					MEDIUM	RPM	1110	1120	1270	1350						
					LOW	RPM	1000	980	1140	1260						
	FAN MOTOR				PERMANENT SPLIT CAPACITOR (INDUCTION)											
					TYPE				IP20							
					INDEX OF PROTECTION (IP)				IP20	IP22	IP20	IP20				
					INSULATION GRADE				B							
					RATED INPUT POWER				HIGH	W	592	618	684	780		
									MEDIUM	W	439	476	563	684		
									LOW	W	350	383	471	595		
					RATED RUNNING CURRENT				HIGH	A	2.70	2.80	3.12	3.55		
									MEDIUM	A	2.00	2.18	2.56	3.11		
LOW									A	1.60	1.78	2.14	2.71			
STARTING CURRENT				A	4.25	3.65	4.12	5.14								
MOTOR OUTPUT				W	100	400	480	600								
POLES				4												
COIL				COPPER												
				TUBE				DIAMETER				mm	9.52			
				FIN				MATERIAL				ALUMINIUM				
								FACE AREA				m <sup>2</sup>	0.28	0.32	0.41	0.48
								ROW				3	3	3	3	
WATER VOLUME				litre	2.21	2.60	3.33	3.80								
AIR QUALITY				WASHABLE SARANET FILTER												
				FILTER				TYPE				2				
CASING				COLOUR				WITHOUT PAINT								

MODE	COOLING	HEATING
ENTERING AIR TEMPERATURE	27°C DB / 19°C WB	20°C DB
ENTERING WATER TEMPERATURE	7°C	50°C (2 Pipes System)
		70°C (4 Pipes System)
LEAVING WATER TEMPERATURE	12°C	60°C (4 Pipes System)

ALL SPECIFICATIONS ARE SUBJECTED TO CHANGE BY THE MANUFACTURER WITHOUT PRIOR NOTICE.

## Engineering Data - Chilled Water Fan Coil Unit Medium Static Pressure (MSP)

MODEL			FWC03G	FWC04G	FWC06G	FWC08G	FWC10G	
NOMINAL COOLING CAPACITY	Btu/h		9000	12000	18000	24000	30000	
	W		2640	3520	5280	7030	8790	
NOMINAL SENSIBLE COOLING CAPACITY	Btu/h		7000	9700	14400	19100	23400	
	W		2050	2840	4220	5600	6860	
NOMINAL TOTAL INPUT POWER	W		78	98	166	210	272	
NOMINAL RUNNING CURRENT	A		0.36	0.45	0.76	0.96	1.25	
POWER SOURCE	V/Ph/Hz		208-230 / 1 / 60					
CONTROL OPERATION	AIR DISCHARGE		DUCTED					
	HIGH		WITHOUT CONTROLLER					
AIR FLOW	CFM		300	400	600	800	1000	
	MEDIUM		220	305	500	650	805	
	LOW		150	200	385	465	600	
EXTERNAL STATIC PRESSURE (H/M/L)	Pa		50/32/15	50/32/15	50/35/20	50/33/17	50/33/18	
NOMINAL WATER FLOW RATE (COOLING)	USGPM		2.00	2.66	3.99	5.33	6.66	
	litres/min		7.57	10.09	15.13	20.18	25.22	
HEAD LOSS (COOLING)	kPa		20	25	34	38	42	
MAX. WORKING PRESSURE	kPa		1608					
SURFACE AIR VELOCITY	m/s		1.17	1.56	1.99	1.69	2.11	
SOUND PRESSURE LEVEL (H/M/L)	dBA		36/30/22	38/32/23	42/38/32	44/38/31	45/41/34	
UNIT DIMENSION	H X W X D		251 X 774 X 461	251 X 774 X 461	251 X 874 X 461	251 X 1264 X 461	251 X 1264 X 461	
PACKING DIMENSION	H X W X D		595 X 984 X 284	595 X 984 X 284	595 X 1084 X 284	595 X 1473 X 284	595 X 1473 X 284	
UNIT WEIGHT	kg		14.5	15	17.5	26	26	
CONDENSATE DRAIN SIZE	mm		19.05					
PIPE CONNECTION	mm		19.05 BSPT FEMALE THREAD ADAPTOR					
FAN	TYPE		BLOWER					
	DRIVE		DIRECT					
	QUANTITY		2	2	2	3	3	
	FAN SPEED	HIGH	RPM	1115	1235	1350	1310	1405
		MEDIUM	RPM	900	990	1170	1080	1190
		LOW	RPM	645	715	935	830	930
	FAN EFFICIENCY	HIGH	%	35.9	36.3	33.5	39.0	36.0
		MEDIUM	%	37.0	36.0	33.9	39.9	38.6
		LOW	%	38.7	37.0	35.4	40.4	39.6
FAN MOTOR	TYPE		PERMANENT SPLIT CAPACITOR (INDUCTION)					
	INDEX OF PROTECTION (IP)		IP20					
	INSULATION GRADE		B					
	QUANTITY		1	1	1	2	2	
	RATED INPUT POWER	HIGH	W	78	98	166	210	272
		MEDIUM	W	50	68	131	154	210
		LOW	W	28	36	93	100	151
	RATED RUNNING CURRENT	HIGH	A	0.36	0.45	0.76	0.96	1.25
		MEDIUM	A	0.23	0.31	0.59	0.70	0.95
		LOW	A	0.12	0.16	0.42	0.45	0.68
	STARTING CURRENT	A	0.43	0.59	1.12	1.27	1.72	
	MOTOR OUTPUT	W	27	43	80	104	140	
	MOTOR EFFICIENCY	HIGH	%	34.2	44.4	53.8	45.2	49.3
MEDIUM		%	24.6	31.5	38.9	31.6	34.7	
LOW		%	15.2	19.1	25.8	21.1	23.3	
POLES		4						
COIL	TUBE	MATERIAL	COPPER					
		DIAMETER	7.00					
	FIN	MATERIAL	ALUMINIUM					
		FACE AREA	m <sup>2</sup>	0.12	0.12	0.14	0.22	0.22
ROW	3							
WATER VOLUME	litre	0.45	0.45	0.62	0.90	1.04		
AIR QUALITY FILTER	TYPE	OPTION (WASHABLE SARANET FILTER OR ALUMINIUM MESH FILTER)						
	QUANTITY	pc	2	2	2	3	3	
CASING	COLOUR		WITHOUT PAINT					

MODE	COOLING
ENTERING AIR TEMPERATURE	27°C DB / 19°C WB
ENTERING WATER TEMPERATURE	7°C
LEAVING WATER TEMPERATURE	12°C

ALL SPECIFICATIONS ARE SUBJECTED TO CHANGE BY THE MANUFACTURER WITHOUT PRIOR NOTICE.

## Engineering Data - Chilled Water Fan Coil Unit

### Medium Static Pressure (MSP)

MODEL			FWC12G	FWC14G	FWC16G	FWC18G	FWC20G	
NOMINAL COOLING CAPACITY	Btu/h		36000	42000	48000	54000	60000	
	W		10550	12310	14070	15830	17580	
NOMINAL SENSIBLE COOLING CAPACITY	Btu/h		27900	33900	38200	43900	50000	
	W		8180	9940	11200	12870	14650	
NOMINAL TOTAL INPUT POWER	W		324	504	694	716	855	
NOMINAL RUNNING CURRENT	A		1.49	2.29	3.16	3.24	3.90	
POWER SOURCE	V/Ph/Hz		208-230/1/60					
CONTROL OPERATION	AIR DISCHARGE OPERATION		DUCTED					
			WITHOUT CONTROLLER					
AIR FLOW	HIGH		CFM	1200	1400	1600	1800	2000
	MEDIUM		CFM	975	1130	1300	1445	1530
	LOW		CFM	810	825	905	1060	1075
EXTERNAL STATIC PRESSURE (H/M/L)	Pa		50/33/23	75/48/24	75/48/24	75/48/25	75/45/22	
NOMINAL WATER FLOW RATE (COOLING)	USGPM		7.99	9.32	10.65	11.98	13.31	
	litres/min		30.26	35.31	40.35	45.40	50.44	
HEAD LOSS (COOLING)	kPa		38	31	27	33	32	
MAX. WORKING PRESSURE	kPa		1608					
SURFACE AIR VELOCITY	m/s		2.05	2.43	2.41	2.71	2.65	
SOUND PRESSURE LEVEL (H/M/L)	dBA		45/41/38	48/44/36	49/45/38	50/46/40	51/47/39	
UNIT DIMENSION	H X W X D	mm	251 X 1514 X 461	363 X 1116 X 660	363 X 1254 X 660	363 X 1254 X 660	363 X 1394 X 660	
PACKING DIMENSION	H X W X D	mm	595 X 1724 X 284	760 X 1331 X 395	760 X 1469 X 395	760 X 1469 X 395	760 X 1609 X 395	
UNIT WEIGHT	kg		30	34	37	38	41	
CONDENSATE DRAIN SIZE	mm		19.05					
PIPE CONNECTION	mm		19.05 BSPT FEMALE THREAD ADAPTOR	25.4 BSPT FEMALE THREAD ADAPTOR				
FAN	TYPE		BLOWER					
	DRIVE		DIRECT					
	QUANTITY		4		2	2	2	2
	FAN SPEED	HIGH	RPM	1320	1065	1115	1210	1220
		MEDIUM	RPM	1050	875	920	1000	1070
		LOW	RPM	965	675	690	740	875
	FAN EFFICIENCY	HIGH	%	32.9	37.6	31.7	33.6	32.4
MEDIUM		%	30.1	38.6	35.0	34.5	40.3	
LOW		%	33.4	42.7	41.0	36.9	46.4	
FAN MOTOR	TYPE		PERMANENT SPLIT CAPACITOR (INDUCTION)					
	INDEX OF PROTECTION (IP)		IP20					
	INSULATION GRADE		B					
	QUANTITY		2	1	1	1	1	
	RATED INPUT POWER	HIGH	W	324	504	694	716	855
		MEDIUM	W	252	366	474	532	567
		LOW	W	202	215	269	334	318
	RATED RUNNING CURRENT	HIGH	A	1.49	2.29	3.16	3.24	3.90
		MEDIUM	A	1.15	1.66	2.16	2.43	2.60
		LOW	A	0.91	0.98	1.25	1.53	1.49
	STARTING CURRENT	A		1.90	3.00	4.30	4.52	6.43
	MOTOR OUTPUT	W		146	248	342	418	446
	MOTOR EFFICIENCY	HIGH	%	49.1	45.0	46.3	50.1	48.6
MEDIUM		%	35.9	34.8	34.3	39.4	33.2	
LOW		%	28.0	24.2	23.2	27.0	20.9	
POLES		4						
COIL	TUBE	MATERIAL	COPPER					
		DIAMETER	mm	7.00	9.52			
	FIN	MATERIAL	ALUMINIUM					
		FACE AREA	m <sup>2</sup>	0.28	0.22	0.26	0.26	0.29
ROW		3						
WATER VOLUME		litre	1.29	2.00	2.32	2.32	2.63	
AIR QUALITY FILTER	TYPE		OPTION ( WASHABLE SARANET FILTER OR ALUMINIUM MESH FILTER)					
	QUANTITY		pc	4	2	3	3	3
CASING	COLOUR		WITHOUT PAINT					

MODE	COOLING
ENTERING AIR TEMPERATURE	27°C DB/ 19°C WB
ENTERING WATER TEMPERATURE	7°C
LEAVING WATER TEMPERATURE	12°C

ALL SPECIFICATIONS ARE SUBJECTED TO CHANGE BY THE MANUFACTURER WITHOUT PRIOR NOTICE.

## Engineering Data - Chilled Water Fan Coil Unit (EC Motor) Low Static Pressure (LSP)

MODEL			FWC02G	FWC03G	FWC04G	FWC06G	
NOMINAL COOLING CAPACITY	Btu/h		6000	9000	12000	18000	
	W		1.76	2.64	3.52	5.28	
NOMINAL SENSIBLE COOLING CAPACITY	Btu/h		5000	7000	9700	14400	
	W		1.47	2.05	2.84	4.22	
NOMINAL TOTAL INPUT POWER	W		19	30	43	80	
NOMINAL RUNNING CURRENT	A		0.20	0.29	0.40	0.69	
POWER SOURCE	V/Ph/Hz		220-240/1/50 & 208-230/1/60				
CONTROL OPERATION	AIR DISCHARGE OPERATION		DUCTED				
			WITHOUT CONTROLLER				
AIR FLOW	HIGH		CFM	200	300	400	600
	MEDIUM		CFM	160	220	305	500
	LOW		CFM	130	150	200	385
EXTERNAL STATIC PRESSURE (H/M/L)	Pa		30/19/12	30/16/7	30/18/7	30/21/13	
NOMINAL WATER FLOW RATE	USGPM		1.32	2.00	2.66	3.99	
	litres/min		5.00	7.57	10.09	15.13	
HEAD LOSS (COOLING)	kPa		7	20	25	34	
MAX. WORKING PRESSURE	kPa		1608				
SURFACE AIR VELOCITY	m/s		1.26	1.17	1.56	1.99	
SOUND PRESSURE LEVEL (H/M/L)	dBa		32/27/21	33/26/21	36/30/22	39/36/31	
UNIT DIMENSION	H X W X D	mm	251x630x461	251x774x461	251x774x461	251x874x461	
PACKING DIMENSION	H X W X D	mm	595x836x284	595x984x284	595x984x284	595x1084x284	
UNIT WEIGHT	kg		13	16	16	17.5	
CONDENSATE DRAIN SIZE	mm		19.05				
PIPE CONNECTION	mm		19.05 BSPT FEMALE THREAD ADAPTOR				
FAN	TYPE		BLOWER				
	DRIVE		DIRECT				
	QUANTITY		1				
	FAN SPEED	HIGH	RPM	985	970	1070	1300
		MEDIUM	RPM	800	740	870	1120
		LOW	RPM	655	540	610	940
	FAN EFFICIENCY	HIGH	%	34.2	34.8	32.5	33.4
		MEDIUM	%	36.7	36.1	34.6	34.1
		LOW	%	40.4	39.6	39.0	35.5
	FAN MOTOR	TYPE		DC BRUSHLESS MOTOR			
INDEX OF PROTECTION (IP)		IP20					
INSULATION GRADE		B					
QUANTITY		1					
RATED INPUT POWER		HIGH	W	19	30	43	80
		MEDIUM	W	10	13	21	56
		LOW	W	6	6	9	30
RATED RUNNING CURRENT		HIGH	A	0.20	0.29	0.40	0.69
		MEDIUM	A	0.15	0.18	0.22	0.50
		LOW	A	0.12	0.13	0.14	0.30
STARTING CURRENT	A		1.20	1.20	1.20	1.20	
MOTOR OUTPUT	W		120	120	120	120	
MOTOR EFFICIENCY	HIGH	%	71.5	77.9	79.9	81.1	
	MEDIUM	%	56.8	64.6	72.4	80.4	
	LOW	%	38.3	44.1	56.4	76.4	
POLES		10					
COIL	TUBE	MATERIAL	COPPER				
		DIAMETER	7.00				
	FIN	MATERIAL	ALUMINIUM				
		FACE AREA	m <sup>2</sup>	0.08	0.12	0.12	0.14
ROW		3					
WATER VOLUME	litre		0.28	0.45	0.45	0.62	
AIR QUALITY FILTER	TYPE		OPTION (WASHABLE SARANET FILTER OR ALUMINIUM MESH FILTER)				
	QUANTITY		2				
CASING	COLOUR		WITHOUT PAINT				

MODE	COOLING
ENTERING AIR TEMPERATURE	27°C DB / 19°C WB
ENTERING WATER TEMPERATURE	7°C
LEAVING WATER TEMPERATURE	12°C

ALL SPECIFICATIONS ARE SUBJECTED TO CHANGE BY THE MANUFACTURER WITHOUT PRIOR NOTICE.

## Engineering Data - Chilled Water Fan Coil Unit (EC Motor)

## Low Static Pressure (LSP)

MODEL			FWC08G	FWC10G	FWC12G			
NOMINAL COOLING CAPACITY			Btu/h	24000	30000	36000		
			W	7.03	8.79	10.55		
NOMINAL SENSIBLE COOLING CAPACITY			Btu/h	19100	23400	27900		
			W	5.60	6.86	8.18		
NOMINAL TOTAL INPUT POWER			W	100	142	163		
NOMINAL RUNNING CURRENT			A	0.87	1.18	1.35		
POWER SOURCE			V/Ph/Hz	220-240/1/50 & 208-230/1/60				
INDOOR UNIT	CONTROL		AIR DISCHARGE OPERATION					
	AIR FLOW		DUCTED WITHOUT CONTROLLER					
	HIGH		CFM	800	1000	1200		
	MEDIUM		CFM	650	805	975		
	LOW		CFM	465	600	810		
	EXTERNAL STATIC PRESSURE (H/M/L)			Pa	30/19/10	30/18/11	30/20/13	
	NOMINAL WATER FLOW RATE			USGPM	5.33	6.66	7.99	
				litres/min	20.18	25.22	30.26	
	HEAD LOSS (COOLING)			kPa	38	42	38	
	MAX. WORKING PRESSURE			kPa	1608			
	SURFACE AIR VELOCITY			m/s	1.69	2.11	2.05	
	SOUND PRESSURE LEVEL (H/M/L)			dBa	40/35/27	42/38/32	43/40/36	
	UNIT DIMENSION		H X W X D	mm	251x1264x461	251x1264x461	251x1514x461	
	PACKING DIMENSION		H X W X D	mm	595x1473x284	595x1473x284	595x1724x284	
	UNIT WEIGHT			kg	26	26	29.5	
	CONDENSATE DRAIN SIZE			mm	19.05			
	PIPE CONNECTION			mm	19.05 BSPT FEMALE THREAD ADAPTOR			
	FAN			TYPE				
				DRIVE				
				DIRECT				
	QUANTITY				3	3	4	
	FAN SPEED			HIGH	RPM	1140	1275	1220
				MEDIUM	RPM	950	1035	1010
				LOW	RPM	710	805	835
	FAN EFFICIENCY			HIGH	%	52.9	43.9	37.7
				MEDIUM	%	53.6	51.2	33.9
LOW				%	57.6	57.3	46.7	
FAN MOTOR			TYPE					
			DC BRUSHLESS MOTOR					
			INDEX OF PROTECTION (IP)					
			IP20					
			INSULATION GRADE					
			B					
QUANTITY				2	2	2		
RATED INPUT POWER			HIGH	W	100	142	163	
			MEDIUM	W	60	84	102	
			LOW	W	29	40	62	
RATED RUNNING CURRENT			HIGH	A	0.87	1.18	1.35	
			MEDIUM	A	0.58	0.77	0.89	
			LOW	A	0.37	0.42	0.60	
STARTING CURRENT			A	2.40	2.40	2.40		
MOTOR OUTPUT			W	120	120	120		
MOTOR EFFICIENCY			HIGH	%	80.1	81.3	80.8	
			MEDIUM	%	77.1	78.6	79.5	
			LOW	%	69.1	73.9	78.0	
POLES				10				
COIL			TUBE MATERIAL					
			COPPER					
			DIAMETER					
			7.00					
			FIN MATERIAL					
			ALUMINIUM					
			FACE AREA					
			m <sup>2</sup>					
			0.22					
			ROW					
			3					
WATER VOLUME			litre	0.90	1.04	1.29		
AIR QUALITY FILTER			TYPE					
			OPTION (WASHABLE SARANET FILTER OR ALUMINIUM MESH FILTER)					
			QUANTITY					
			pc					
			3					
			3					
			4					
CASING			COLOUR					
			WITHOUT PAINT					

MODE	COOLING
ENTERING AIR TEMPERATURE	27°C DB / 19°C WB
ENTERING WATER TEMPERATURE	7°C
LEAVING WATER TEMPERATURE	12°C

ALL SPECIFICATIONS ARE SUBJECTED TO CHANGE BY THE MANUFACTURER WITHOUT PRIOR NOTICE.

## Engineering Data - Chilled Water Fan Coil Unit (EC Motor) Medium Static Pressure (MSP)

MODEL			FWC03G	FWC04G	FWC06G	
NOMINAL COOLING CAPACITY	Btu/h		9000	12000	18000	
	W		2.64	3.52	5.28	
NOMINAL SENSIBLE COOLING CAPACITY	Btu/h		7000	9700	14400	
	W		2.05	2.84	4.22	
NOMINAL TOTAL INPUT POWER	W		40	55	94	
NOMINAL RUNNING CURRENT	A		0.38	0.49	0.80	
POWER SOURCE	V/Ph/Hz		220-240/1/50 & 208-230/1/60			
INDOOR UNIT	CONTROL		AIR DISCHARGE OPERATION			
	AIR FLOW		DUCTED WITHOUT CONTROLLER			
	HIGH		CFM	300	400	600
	MEDIUM		CFM	220	305	500
	LOW		CFM	150	200	385
	EXTERNAL STATIC PRESSURE (H/M/L)		Pa	50/32/15	50/32/15	50/35/20
	NOMINAL WATER FLOW RATE		USGPM	2.00	2.66	3.99
			litres/min	7.57	10.09	15.13
	HEAD LOSS (COOLING)		kPa	20	25	34
	MAX. WORKING PRESSURE		kPa	1608		
	SURFACE AIR VELOCITY		m/s	1.17	1.56	1.99
	SOUND PRESSURE LEVEL (H/M/L)		dB(A)	35/29/20	37/31/22	41/37/31
	UNIT DIMENSION		H X W X D mm	251x774x461	251x774x461	251x874x461
	PACKING DIMENSION		H X W X D mm	595x984x284	595x984x284	595x1084x284
	UNIT WEIGHT		kg	16	16	17.5
CONDENSATE DRAIN SIZE		mm	19.05			
PIPE CONNECTION		mm	19.05 BSPT FEMALE THREAD ADAPTOR			
FAN	TYPE		BLOWER			
	DRIVE		DIRECT			
	QUANTITY		2			
	FAN SPEED	HIGH	RPM	1115	1235	1350
		MEDIUM	RPM	900	990	1170
		LOW	RPM	645	715	935
	FAN EFFICIENCY	HIGH	%	35.9	36.3	33.5
		MEDIUM	%	37.0	36.0	33.9
		LOW	%	38.7	37.0	35.4
	FAN MOTOR	TYPE		DC BRUSHLESS MOTOR		
INDEX OF PROTECTION (IP)		IP20				
INSULATION GRADE		B				
QUANTITY		1				
RATED INPUT POWER		HIGH	W	40	55	94
		MEDIUM	W	19	27	62
		LOW	W	9	11	34
RATED RUNNING CURRENT		HIGH	A	0.38	0.49	0.80
		MEDIUM	A	0.20	0.26	0.56
		LOW	A	0.13	0.16	0.32
STARTING CURRENT		A	1.20	1.20	1.20	
MOTOR OUTPUT		W	120	120	120	
MOTOR EFFICIENCY		HIGH	%	75.0	76.4	81.5
		MEDIUM	%	67.2	72.0	81.4
		LOW	%	54.1	59.3	77.8
POLES		10				
COIL	TUBE	MATERIAL	COPPER			
		DIAMETER mm	7.00			
	FIN	MATERIAL	ALUMINIUM			
		FACE AREA m <sup>2</sup>	0.12	0.12	0.14	
	ROW		3			
WATER VOLUME		litre	0.45	0.45	0.62	
AIR QUALITY	FILTER		OPTION (WASHABLE SARANET FILTER OR ALUMINIUM MESH FILTER)			
	QUANTITY		pc	2	2	2
CASING		COLOUR	WITHOUT PAINT			

MODE	COOLING
ENTERING AIR TEMPERATURE	27°C DB / 19°C WB
ENTERING WATER TEMPERATURE	7°C
LEAVING WATER TEMPERATURE	12°C

ALL SPECIFICATIONS ARE SUBJECTED TO CHANGE BY THE MANUFACTURER WITHOUT PRIOR NOTICE.



## Engineering Data - Chilled Water Fan Coil Unit (EC Motor)

### Medium Static Pressure (MSP)

MODEL			FWC08G	FWC10G	FWC12G		
NOMINAL COOLING CAPACITY	Btu/h		24000	30000	36000		
	W		7.03	8.79	10.55		
NOMINAL SENSIBLE COOLING CAPACITY	Btu/h		19100	23400	27900		
	W		5.60	6.86	8.18		
NOMINAL TOTAL INPUT POWER	W		120	170	189		
NOMINAL RUNNING CURRENT	A		1.02	1.38	1.54		
POWER SOURCE	V/Ph/Hz		220-240/1/50 & 208-230/1/60				
CONTROL	AIR DISCHARGE OPERATION		DUCTED				
			WITHOUT CONTROLLER				
	HIGH		CFM	800	1000	1200	
AIR FLOW	MEDIUM		CFM	650	805	975	
	LOW		CFM	465	600	810	
EXTERNAL STATIC PRESSURE (H/M/L)	Pa		50/33/17	50/33/18	50/33/23		
NOMINAL WATER FLOW RATE	USGPM		5.33	6.66	7.99		
	litres/min		20.18	25.22	30.26		
HEAD LOSS (COOLING)	kPa		38	42	38		
MAX. WORKING PRESSURE	kPa		1608				
SURFACE AIR VELOCITY	m/s		1.69	2.11	2.05		
SOUND PRESSURE LEVEL (H/M/L)	dB(A)		43/37/30	44/40/33	44/40/37		
UNIT DIMENSION	H X W X D	mm	251x1264x461	251x1264x461	251x1514x461		
PACKING DIMENSION	H X W X D	mm	595x1473x284	595x1473x284	595x1724x284		
UNIT WEIGHT	kg		26	26	29.5		
CONDENSATE DRAIN SIZE	mm		19.05				
PIPE CONNECTION	mm		19.05 BSPT FEMALE THREAD ADAPTOR				
INDOOR UNIT	FAN	TYPE		BLOWER			
		DRIVE		DIRECT			
		QUANTITY		3	3	4	
		FAN SPEED	HIGH	RPM	1310	1405	1320
			MEDIUM	RPM	1080	1190	1050
			LOW	RPM	830	930	965
		FAN EFFICIENCY	HIGH	%	39.0	36.0	32.9
			MEDIUM	%	39.9	38.6	30.1
			LOW	%	40.4	39.6	33.4
		FAN MOTOR	TYPE		DC BRUSHLESS MOTOR		
INDEX OF PROTECTION (IP)			IP20				
INSULATION GRADE			B				
QUANTITY			2	2	2		
RATED INPUT POWER	HIGH		W	120	170	189	
	MEDIUM		W	68	101	126	
	LOW		W	34	45	72	
RATED RUNNING CURRENT	HIGH		A	1.02	1.38	1.54	
	MEDIUM		A	0.63	0.89	1.09	
	LOW		A	0.40	0.46	0.68	
STARTING CURRENT	A		2.40	2.40	2.40		
MOTOR OUTPUT	W		120	120	120		
MOTOR EFFICIENCY	HIGH		%	80.7	82.1	81.7	
	MEDIUM	%	78.6	80.7	80.9		
	LOW	%	70.7	74.6	78.5		
POLES		10					
COIL	TUBE	MATERIAL	COPPER				
		DIAMETER	7				
	FIN	MATERIAL	ALUMINIUM				
		FACE AREA	m <sup>2</sup>	0.22	0.22	0.28	
	ROW		3				
WATER VOLUME	litre		0.90	1.04	1.29		
AIR QUALITY	FILTER	TYPE	OPTION (WASHABLE SARANET FILTER OR ALUMINIUM MESH FILTER)				
		QUANTITY	pc	3	3	4	
CASING	COLOUR		WITHOUT PAINT				

MODE	COOLING
ENTERING AIR TEMPERATURE	27°C DB / 19°C WB
ENTERING WATER TEMPERATURE	7°C
LEAVING WATER TEMPERATURE	12°C

ALL SPECIFICATIONS ARE SUBJECTED TO CHANGE BY THE MANUFACTURER WITHOUT PRIOR NOTICE.



## Engineering Data - Chilled Water Fan Coil Unit

MODEL			FUD20B	FUD25B	FUD30B	
NOMINAL COOLING CAPACITY			Btu/h	75600	95000	
			W	22160	27840	
NOMINAL SENSIBLE COOLING CAPACITY			Btu/h	53700	69400	
			W	15740	20340	
NOMINAL HEATING CAPACITY (ENTERING WATER TEMP. = 50°C)			Btu/h	78000	97500	
			W	22860	28580	
NOMINAL TOTAL INPUT POWER			W	1098	1396	
NOMINAL RUNNING CURRENT			A	5.16	7.04	
POWER SOURCE			V/Ph/Hz	208-230 / 1 / 60	208-230 / 3 / 60	
INDOOR UNIT	CONTROL		AIR DISCHARGE OPERATION			
			DUCTED			
			WITHOUT CONTROLLER			
	AIR FLOW		HIGH	CFM	2500	3200
			MEDIUM	CFM	2100	3000
			LOW	CFM	1750	2800
	EXTERNAL STATIC PRESSURE		Pa	100 / 72 / 50	100 / 80 / 60	230
	NOMINAL WATER FLOW RATE		USGPM	16.90	21.10	27.70
			litres/min	64.00	80.00	105.00
	HEAD LOSS (COOLING)		kPa	34.5	42.0	48.8
	HEAD LOSS (HEATING) : 50°C		kPa	32.9	27.4	31.5
	MAX. WORKING PRESSURE		kPa	1608		
	SURFACE AIR VELOCITY		m/s	2.19	2.8	1.96
	SOUND PRESSURE LEVEL		dBA	50 / 46 / 42	54 / 52 / 50	58
	UNIT DIMENSION		H X W X D	572 X 1402 X 605		885 X 1540 X 850
	PACKING DIMENSION		H X W X D	762 X 1605 X 880		1154 X 1787 X 1188
	UNIT WEIGHT		kg	92	102	176
	CONDENSATE DRAIN SIZE		mm	19.05		
	PIPE CONNECTION		mm	31.75 BSP FEMALE THREAD ADAPTOR		
	FAN		TYPE DRIVE		BLOWER	
					DIRECT	BELT
	FAN SPEED		HIGH	RPM	835	950
			MEDIUM	RPM	720	885
			LOW	RPM	615	805
	FAN MOTOR		TYPE		PERMANENT SPLIT CAPACITOR (INDUCTION)	THREE PHASE INDUCTION
			INDEX OF PROTECTION (IP)		IP20	
			INSULATION GRADE		F	B
	RATED INPUT POWER		HIGH	W	1060	1351
			MEDIUM	W	810	1082
			LOW	W	643	964
RATED RUNNING CURRENT		HIGH	A	4.80	6.16	
		MEDIUM	A	3.77	5.02	
		LOW	A	3.05	4.54	
STARTING CURRENT		A	3.23	5.10	7 - 56.28	
MOTOR OUTPUT		W	375	500	2200	
POLES				6	6	
COIL		TUBE MATERIAL DIAMETER		COPPER		
				9.53		
		FIN MATERIAL		ALUMINIUM		
		FACE AREA		0.54	0.54	
		ROW		3	4	
		WATER VOLUME		4.53	6.27	
AIR QUALITY		FILTER TYPE		WASHABLE SARANET FILTER		
		QUANTITY		2	3	
CASING		COLOUR		IVORY WHITE		

\* The external static pressure for FUD30/40B above is inclusive of R29 filters whereby R29 filters contribute a pressure drop of 81Pa.

MODE	COOLING	HEATING
ENTERING AIR TEMPERATURE	27°C DB / 19°C WB	20°C DB
ENTERING WATER TEMPERATURE	7°C	50°C (2 Pipes System) 70°C (4 Pipes System)
LEAVING WATER TEMPERATURE	12°C	60°C (4 Pipes System)

ALL SPECIFICATIONS ARE SUBJECTED TO CHANGE BY THE MANUFACTURER WITHOUT PRIOR NOTICE

# Outlines & Dimensions

## Indoor Unit

Model: FWW03/04/05/06L

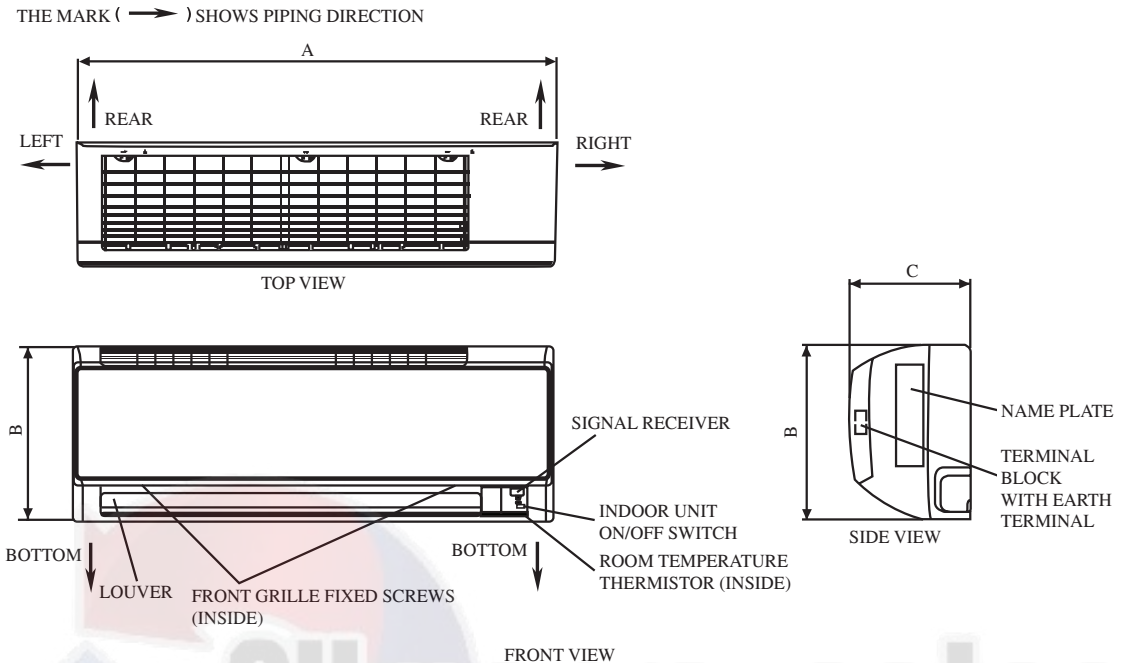

NOTE: PLEASE BASED ON ACTUAL INSTALLATION PLATE DESIGN IN THE UNIT FOR INSTALLATION PLATE FWW02/03/04L DIMENSION REFERENCE AT PAGE 1&2.

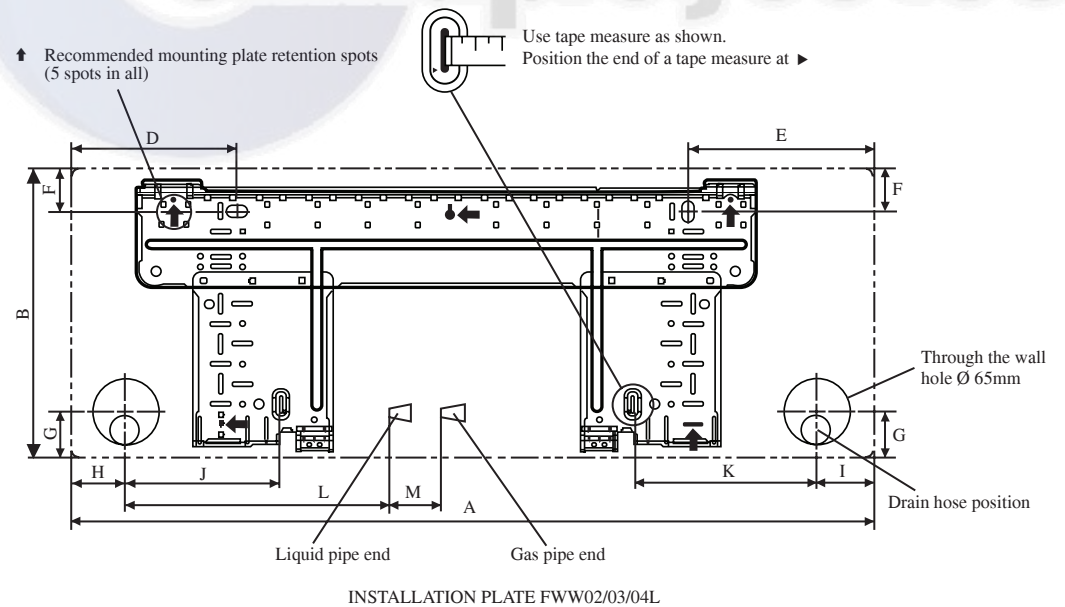

Dimension	A	B	C	D	E	F	G	H	I	J	K	L	M
Model													
FWW03/04L	800	288	206	166	184	42	46	55	56	154	182	263	52

Note: Dimension in mm

Model: FWW03/04/05/06L

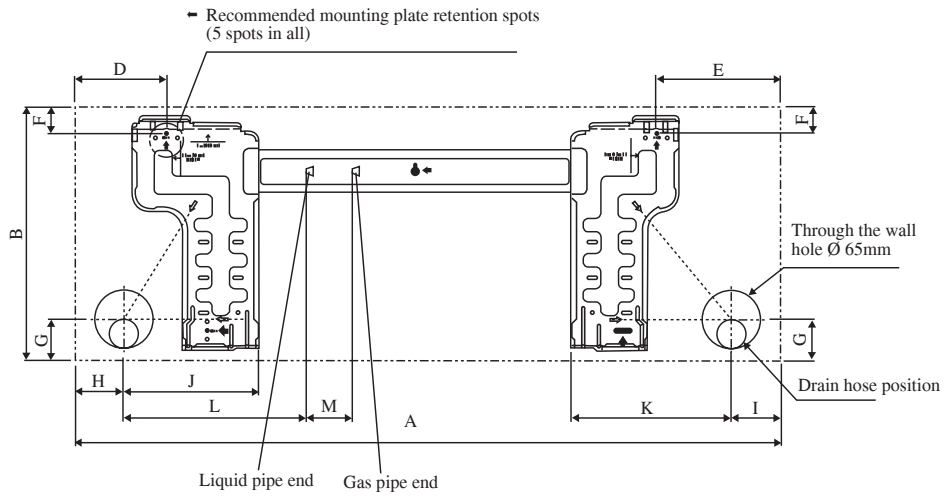

ALTERNATIVE INSTALLATION PLATE FWW02/03/04L

Dimension	A	B	C	D	E	F	G	H	I	J	K	L	M
Model													
FWW03/04L	800	288	206	104	141	30	46	55	56	153	181	207	52

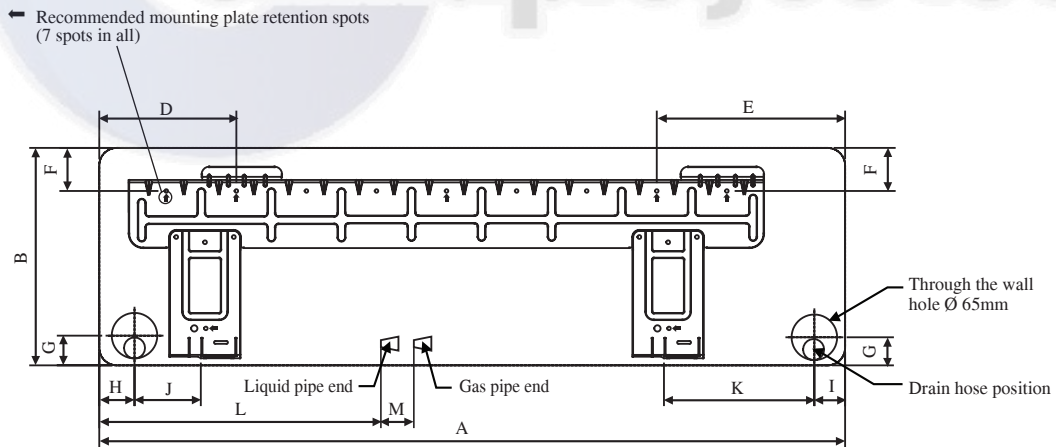

INSTALLATION PLATE FWW05/06L

Dimension	A	B	C	D	E	F	G	H	I	J	K	L	M
Model													
FWW05/06L	1065	310	224	190	173	61	40	45	48	91	219	580	45

Note: Dimension in mm

Model: FWKE05/08/11E(H)

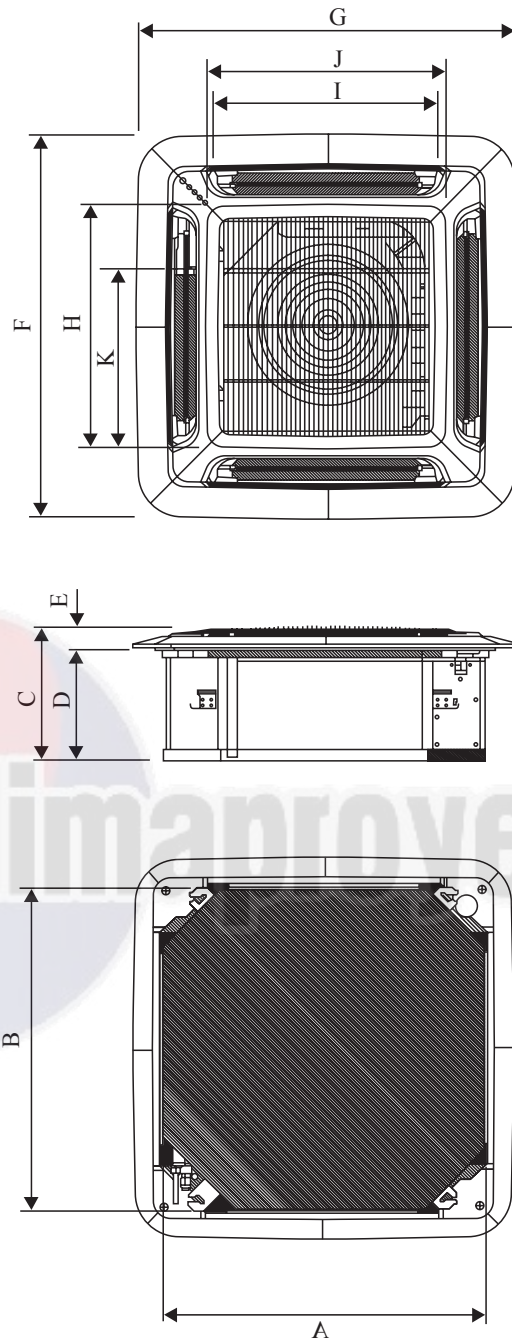

Dimension	A	B	C	D	E	F	G	H	I	J	K
Model											
FWKE05/08E(H)	820	820	340	300	40	990	990	627	627	607	430
FWKE11E(H)	820	820	375	335	40	990	990	627	627	607	430

Note: Dimension in mm

Model: FWC03C

LEFT PIPING

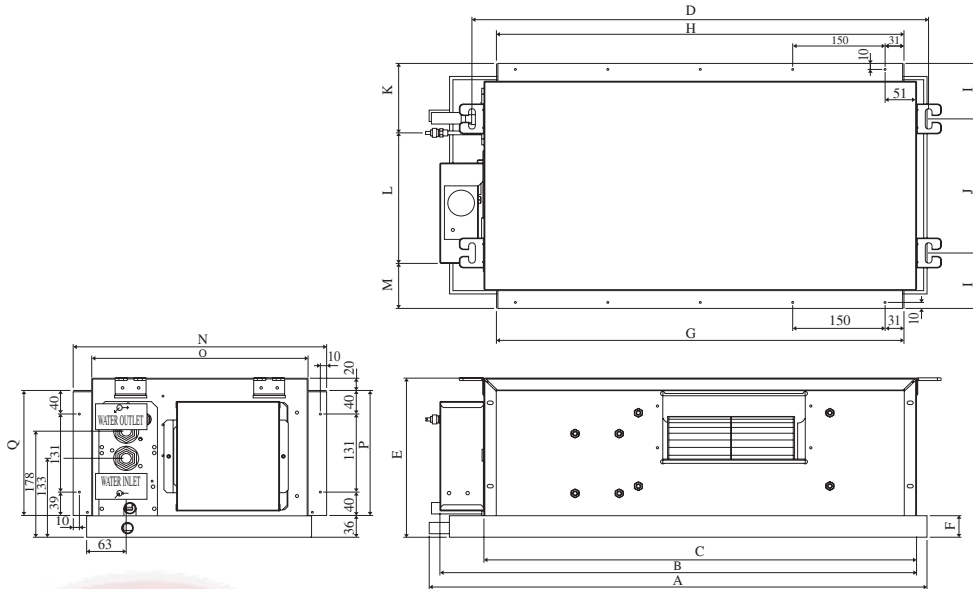

RIGHT PIPING

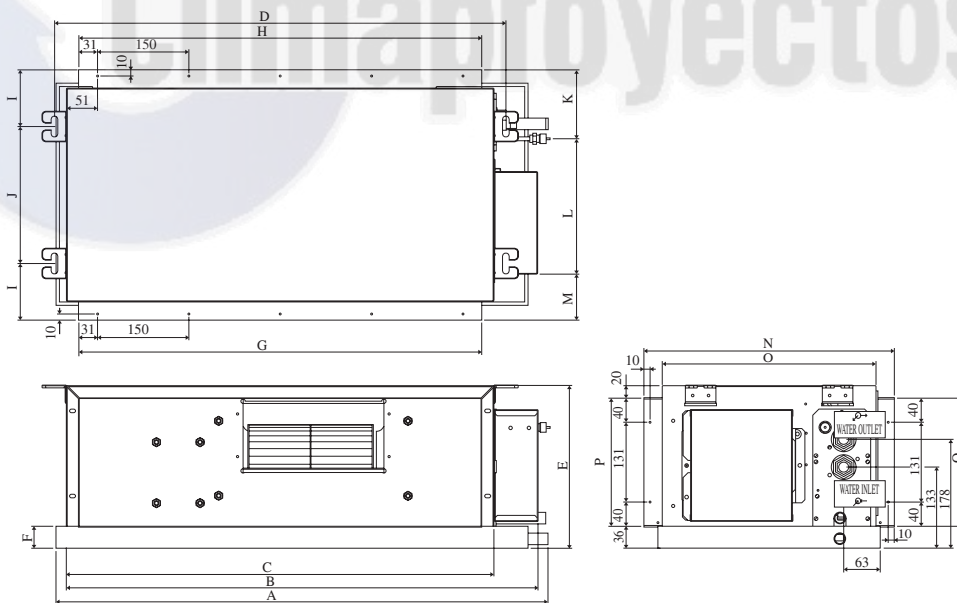

Dimension	A	B	C	D	E	F	G	H	I	J	K	L	M	N	O	P	Q
Model FWC03C	808	774	702	741	267	36	662	662	93	225	115	218	76	411	351	211	211

Note: Dimension in mm

Model: FWC04/06/07C

LEFT PIPING

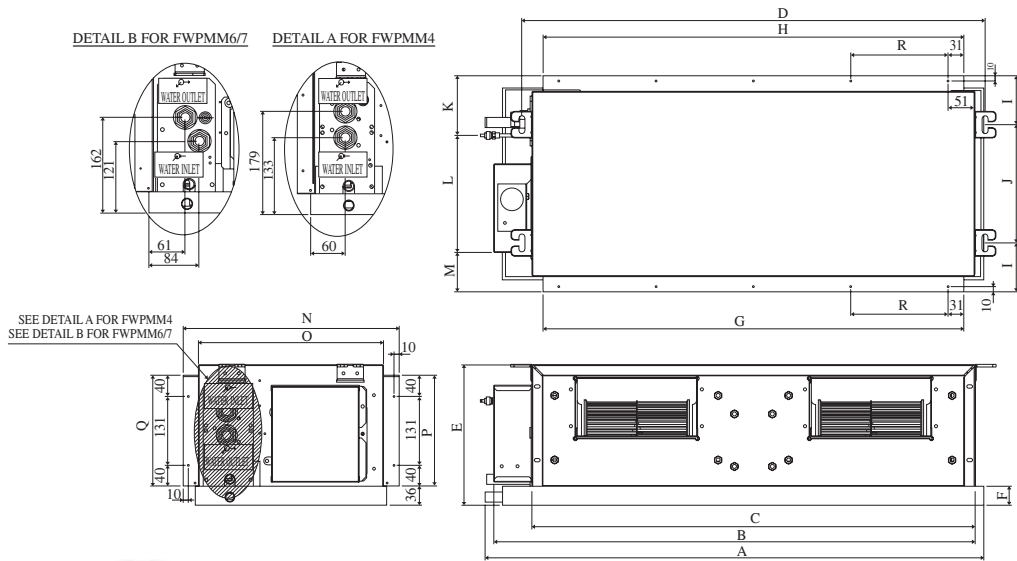

RIGHT PIPING

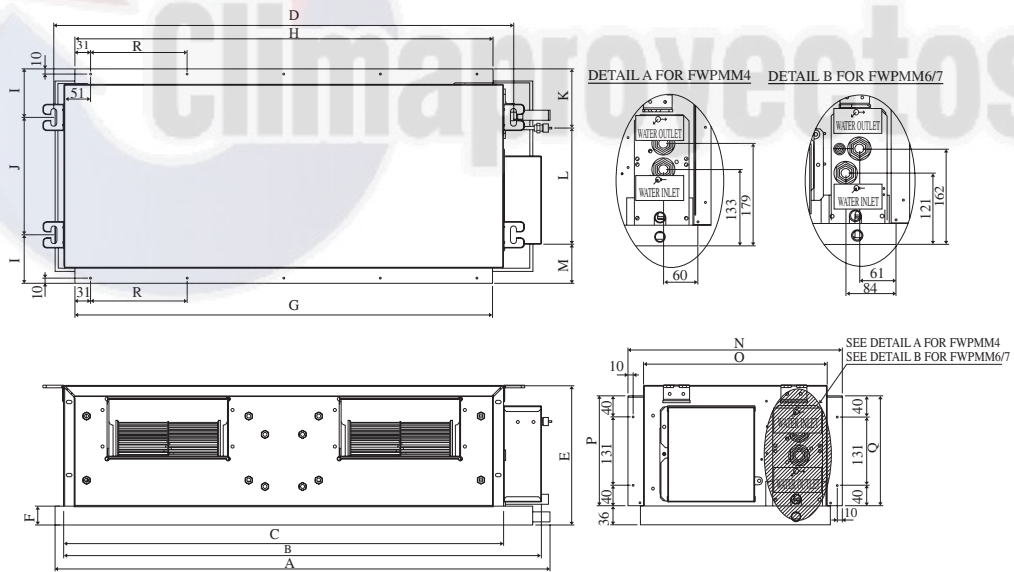

Dimension	A	B	C	D	E	F	G	H	I	J	K	L	M	N	O	P	Q	R
Model FWC04C	939	914	842	881	267	36	802	802	93	225	114	222	76	412	351	211	211	185
Model FWC06C	1108	1075	1002	1041	267	36	962	962	93	225	64	272	76	412	351	211	211	179
Model FWC07C	1243	1209	1137	1176	267	36	1097	1097	93	225	64	272	76	412	351	211	211	206

Note: Dimension in mm

Model: FWC09/12/14/16C

LEFT PIPING

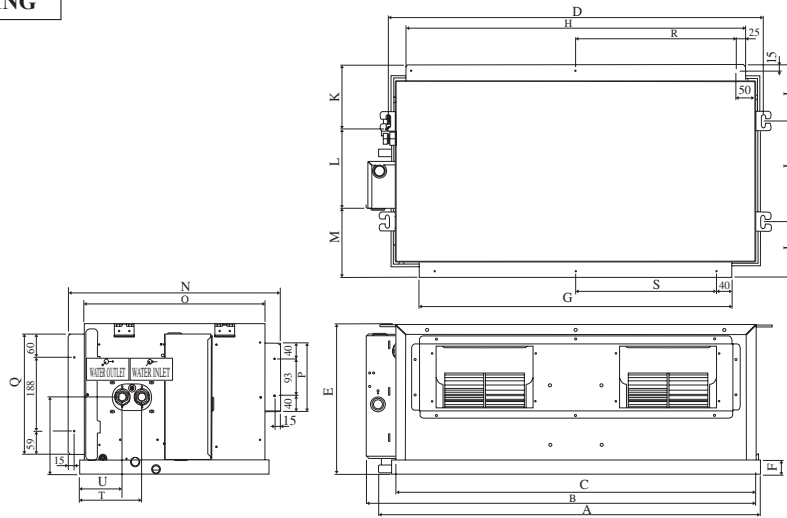

RIGHT PIPING

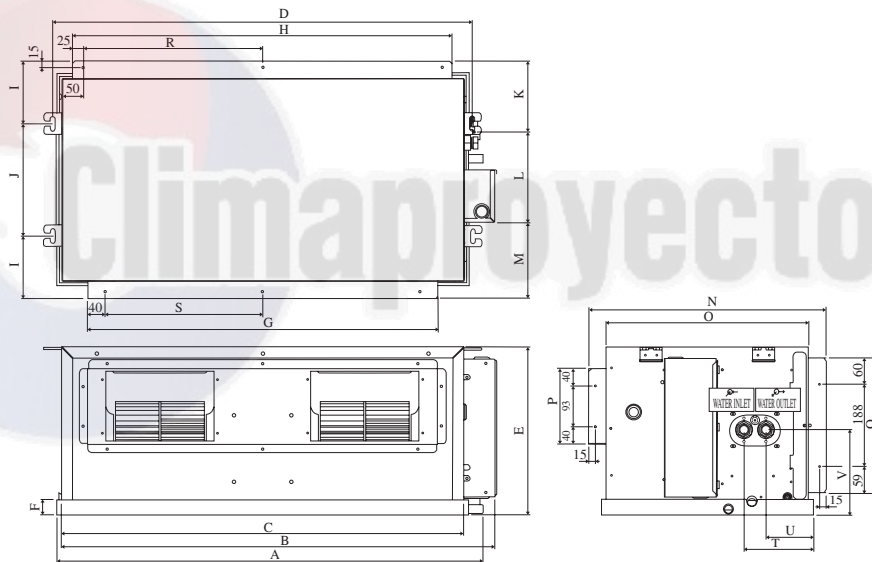

Dimension	A	B	C	D	E	F	G	H	I	J	K	L
Model FWC09C	972	988	917	956	384	36	798	866	143	256	162	206
Model FWC12C	1088	1105	1033	1072	384	36	798	982	143	256	162	206
Model FWC14C	1342	1358	1287	1326	384	36	798	1236	143	256	159	209
Model FWC16C	1542	1558	1487	1526	384	36	798	1436	143	256	159	199

Dimension	M	N	O	P	Q	R	S	T	U	V
Model FWC09C	173	541	462	173	307	409	359	159	109	196
Model FWC12C	173	541	462	173	307	467	359	159	109	196
Model FWC14C	173	541	462	173	307	594	359	156	106	196
Model FWC16C	183	541	462	173	307	694	359	154	104	196

Note: Dimension in mm

Model: FWC03/04/06G (MSP)

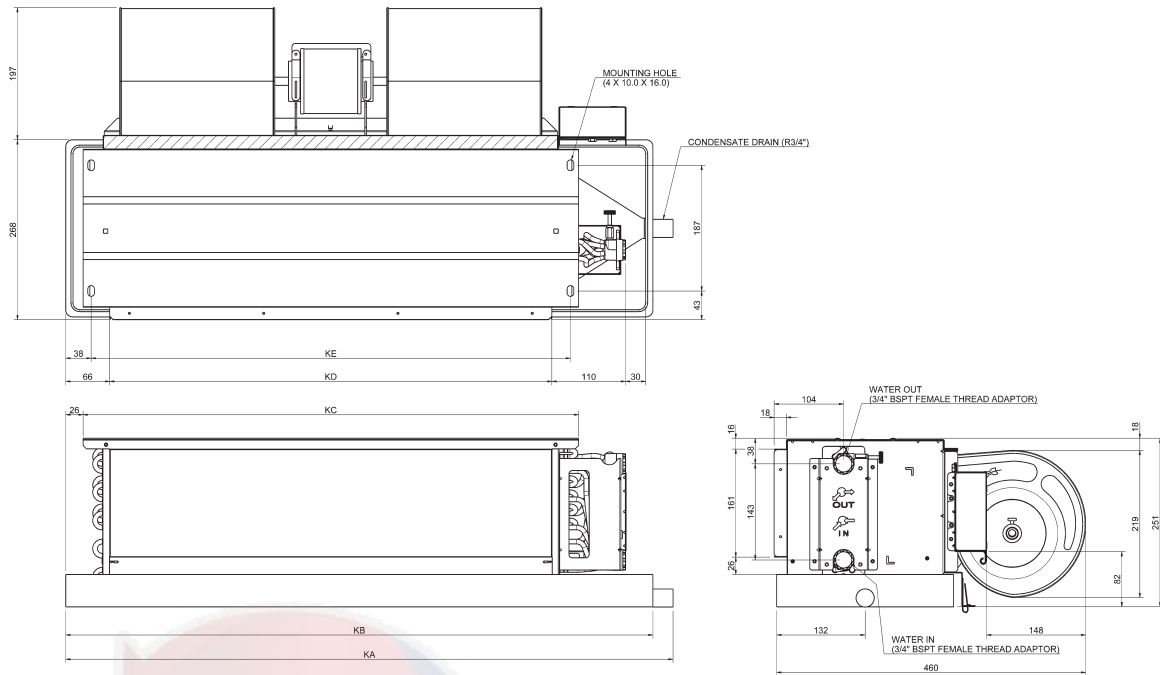

Dimension	KA	KB	KC	KD	KE
Model FWC03/04G	801	774	638	558	614
Model FWC06G	901	874	738	658	714

Note: Dimension in mm



Model: FWC08/10G (MSP)

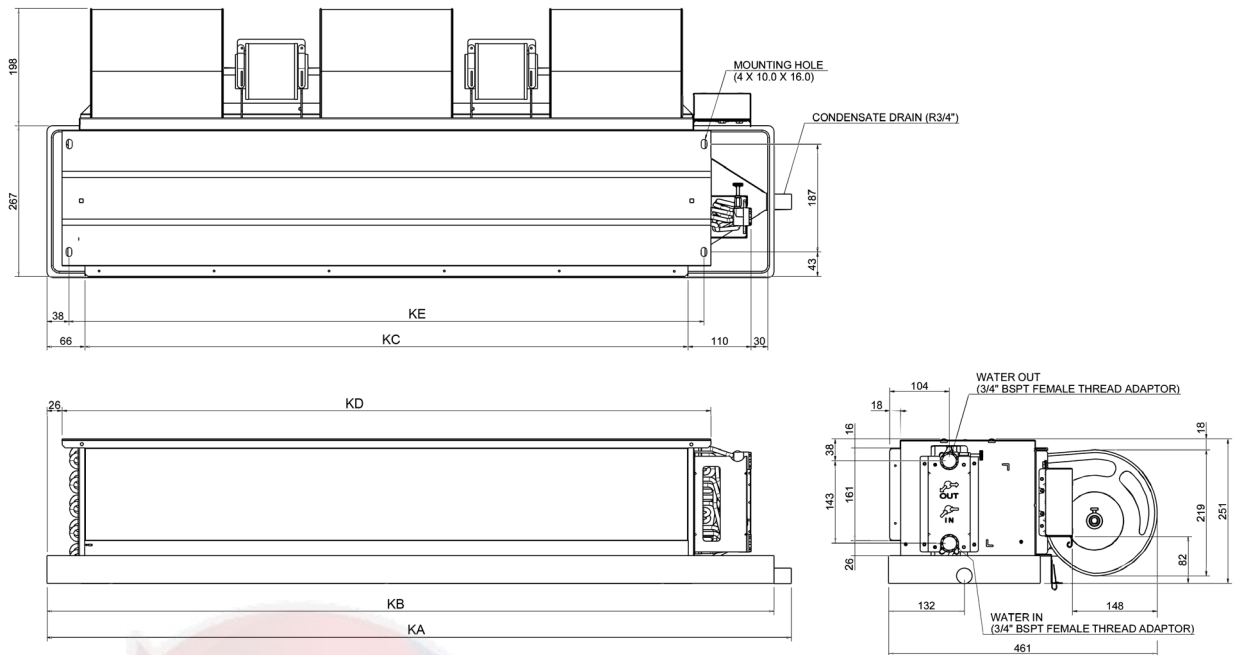

Dimension	KA	KB	KC	KD	KE
Model					
<b>FWC08/10G</b>	1289	1264	1048	1127	1103

Note: Dimension in mm

Model: FWC12G (MSP)

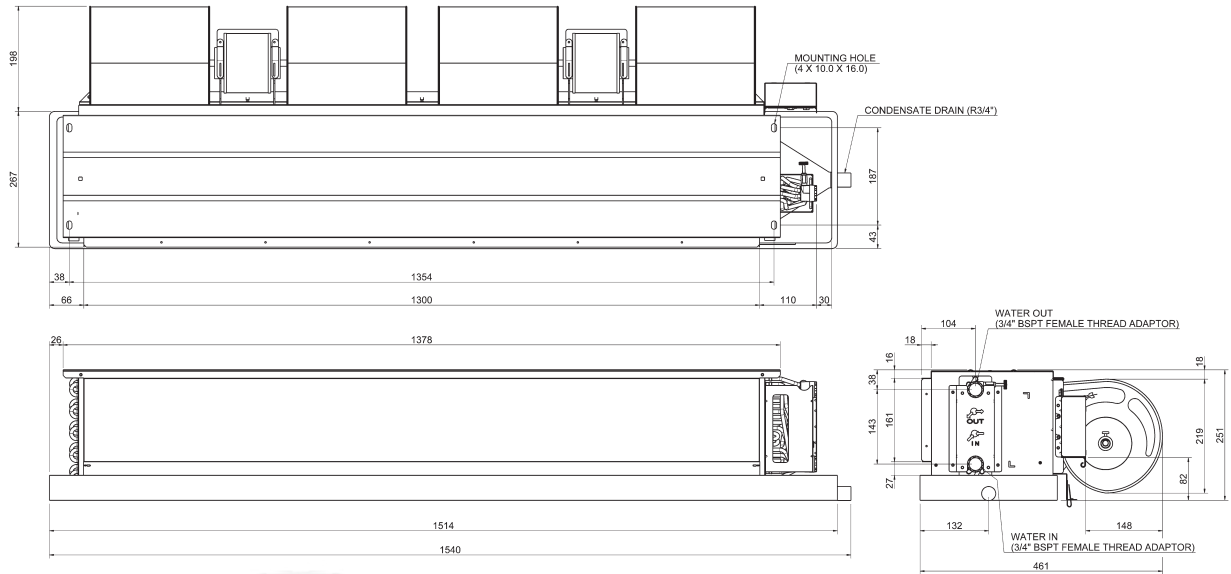

Dimension	KA	KB	KC	KD	KE
Model					
FWC12G	1540	1514	1300	1378	1354

Note: Dimension in mm

Model: FWC14/16/18/20G (MSP)

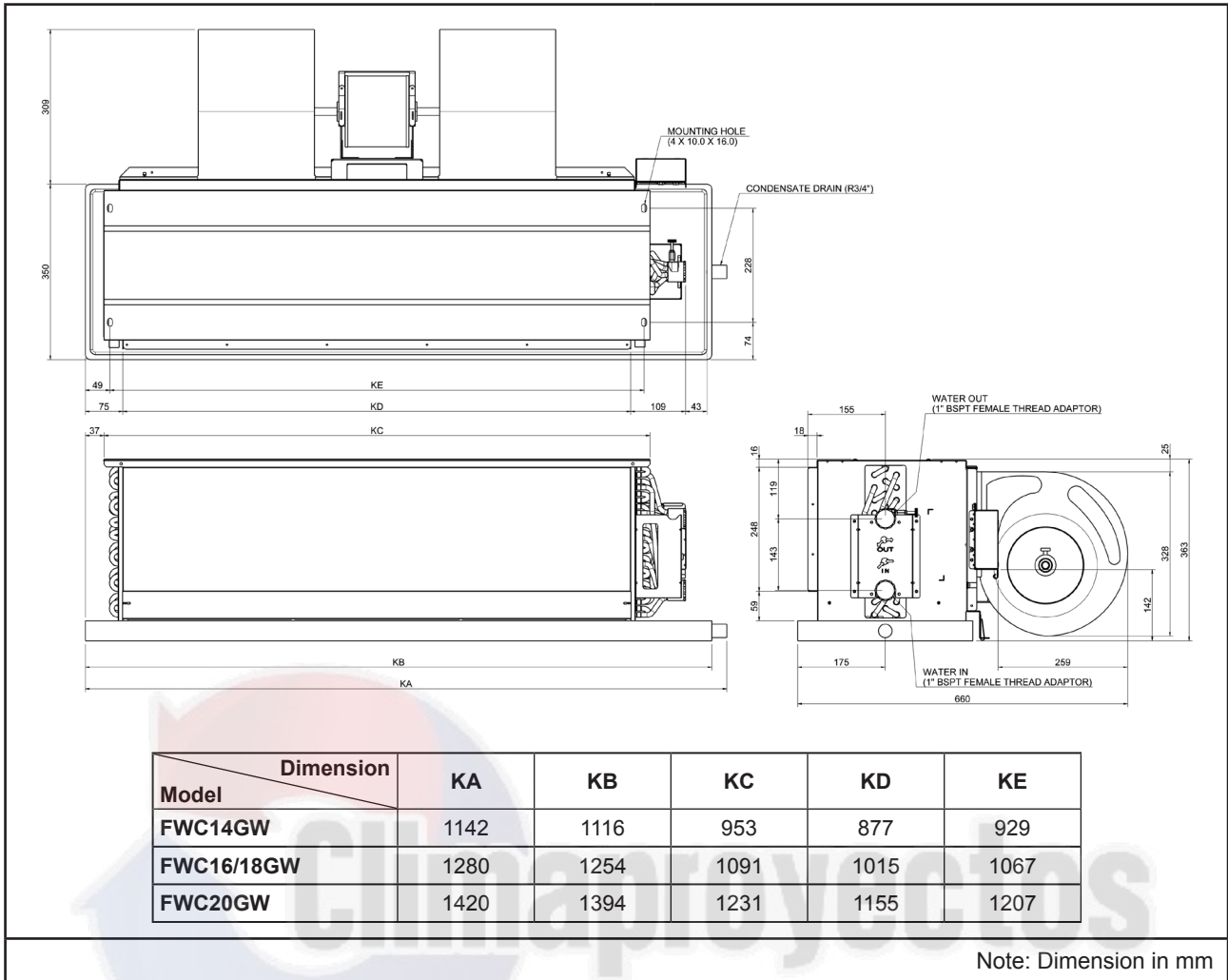

Model: FWC02/03/04/06/08/10/12G EC (LSP , MSP)

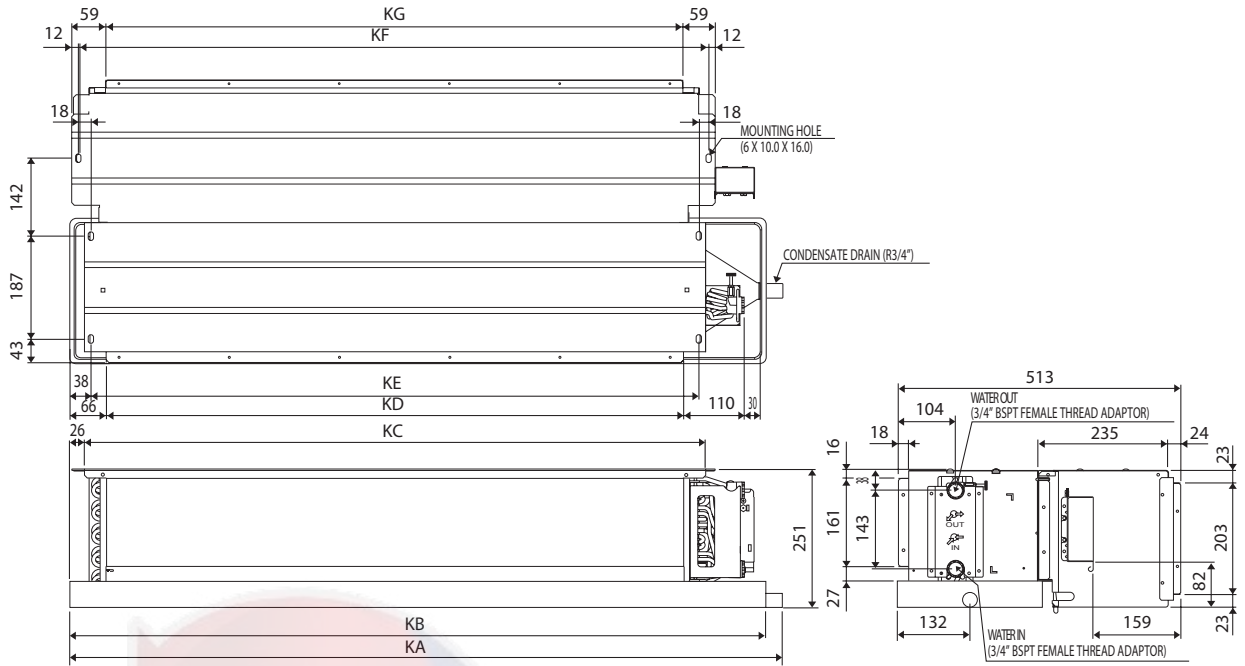

Model \ Dimension	KA	KB	KC	KD	KE	KF	KG
<b>FWC02GW</b>	657	630	494	414	470	508	414
<b>FWC03/04GW</b>	801	774	638	558	614	652	558
<b>FWC06GW</b>	901	874	738	658	714	752	658
<b>FWC08/10GW</b>	1289	1264	1127	1049	1103	1141	1047
<b>FWC12GW</b>	1540	1514	1378	1300	1354	1392	1298

Note: Dimension in mm

Model: FUD20/25B

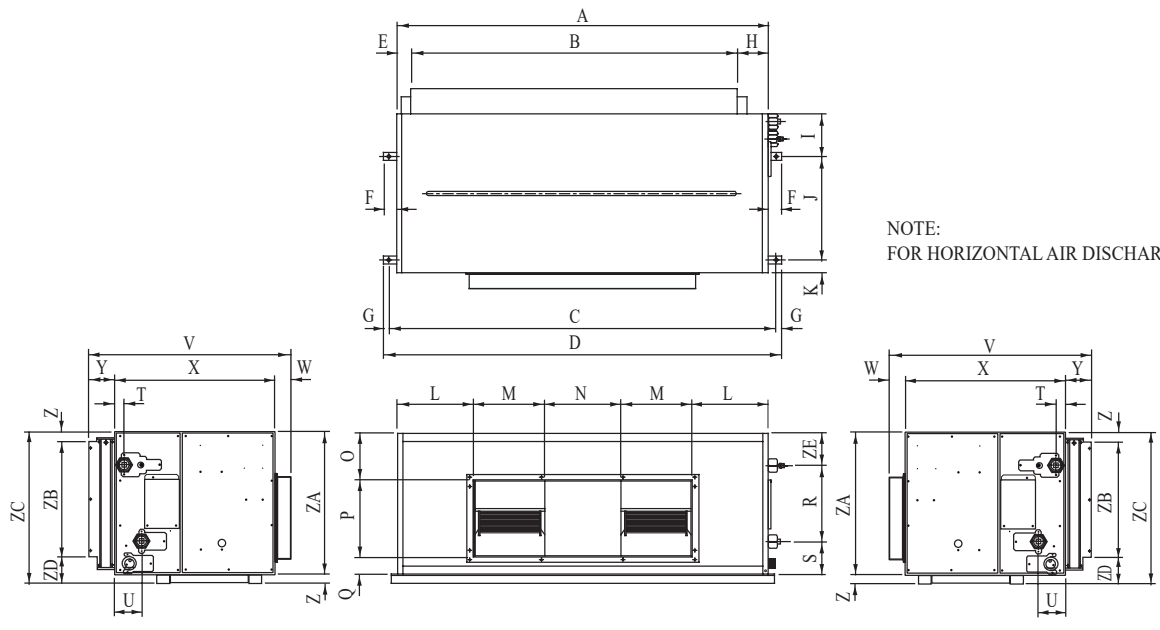

LEFT PIPING (OPTIONAL)

RIGHT PIPING (STANDARD)

Dimension	A	B	C	D	E	F	G	H	I	J	K	L	M	N	O	P	Q
Model																	
FUD20B	1402	1232	1462	1502	53	50	20	117	163	394	48	287	270	288	177	295	65
FUD25B	1402	1232	1462	1502	53	50	20	117	163	394	48	287	270	288	177	295	65

Dimension	R	S	T	U	V	W	X	Y	Z	ZA	ZB	ZC	ZD	ZE
Model														
FUD20B	302	103	33	72	761	60	605	96	35	537	437	572	100	132
FUD25B	289	103	33	72	761	60	605	96	35	537	437	572	100	145

Note: Dimension in mm

**Model: FUD30B (Horizontal Air Discharge)**

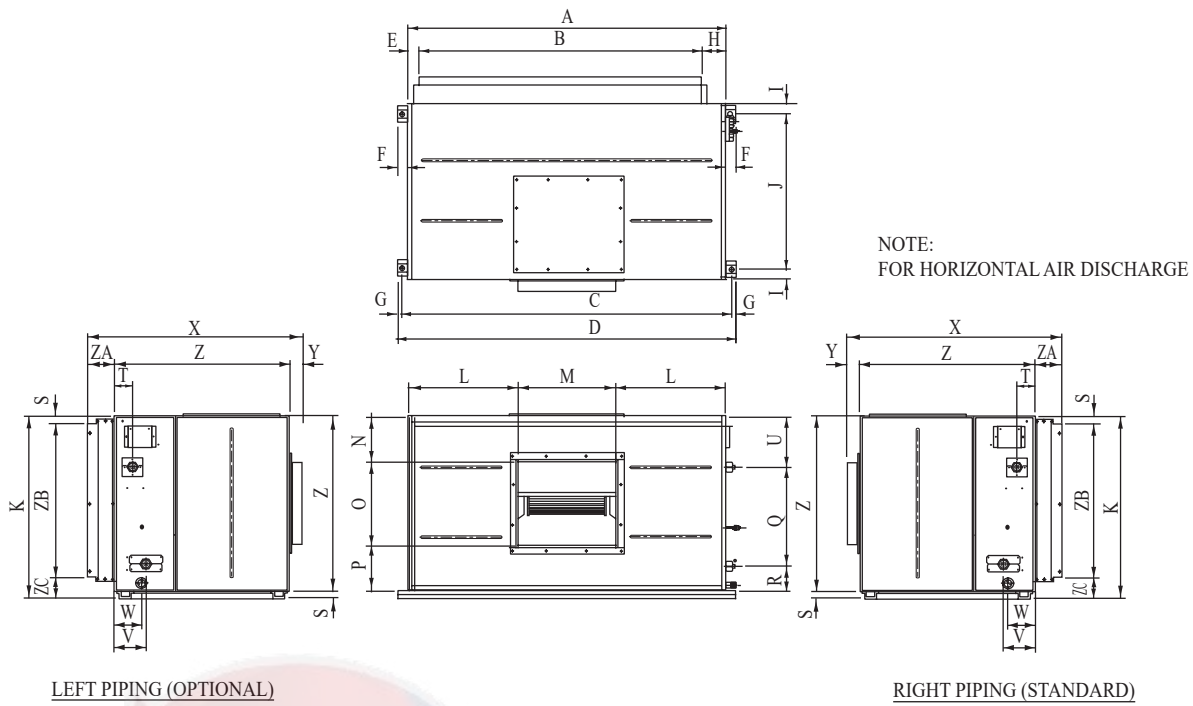

Dimension	A	B	C	D	E	F	G	H	I	J	K	L	M	N	O
Model															
<b>FUD30B</b>	1540	1370	1600	1640	53	50	20	117	48	754	885	533	474	220	408

Dimension	P	Q	R	S	T	U	V	W	X	Y	Z	ZA	ZB	ZC
Model														
<b>FUD30B</b>	222	468	120	35	88	262	155	132	1040	60	850	130	747	103

Note: Dimension in mm

**Model: FUD30B (Vertical Air Discharge)**

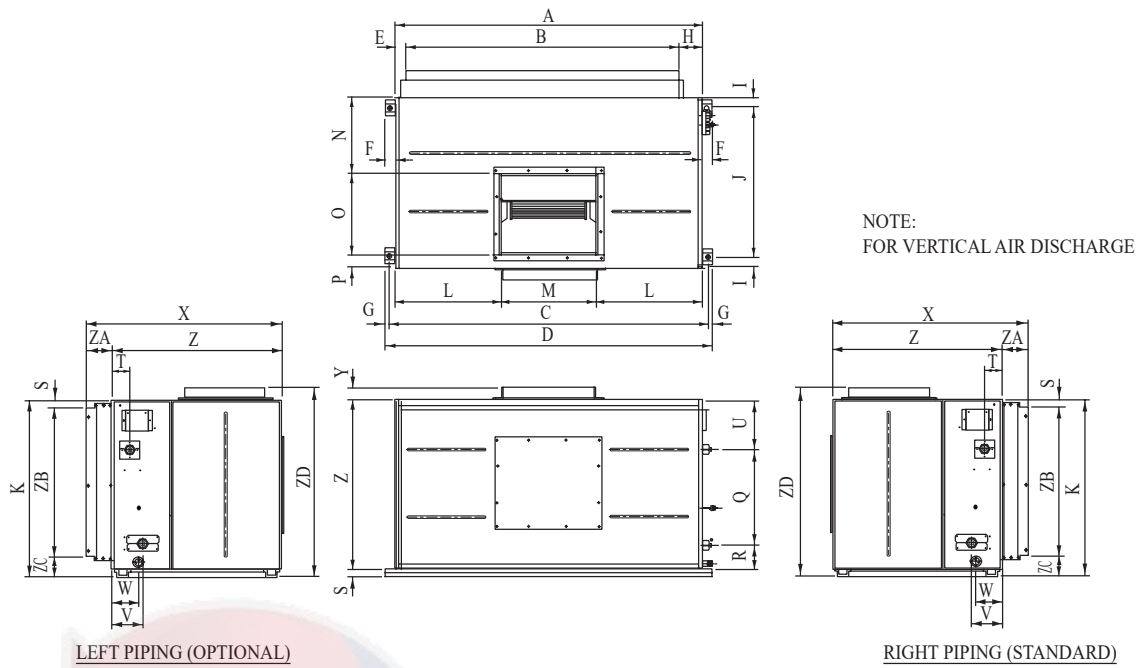

Dimension	A	B	C	D	E	F	G	H	I	J	K	L	M	N	O
<b>Model</b>															
<b>FUD30B</b>	1540	1370	1600	1640	53	50	20	117	48	754	885	533	474	382	408

Dimension	P	Q	R	S	T	U	V	W	X	Y	Z	ZA	ZB	ZC	ZD
<b>Model</b>															
<b>FUD30B</b>	60	468	120	35	88	262	155	132	980	60	850	130	747	103	945

Note: Dimension in mm

# Wiring Diagrams

Model: FWW03/04/05/06L

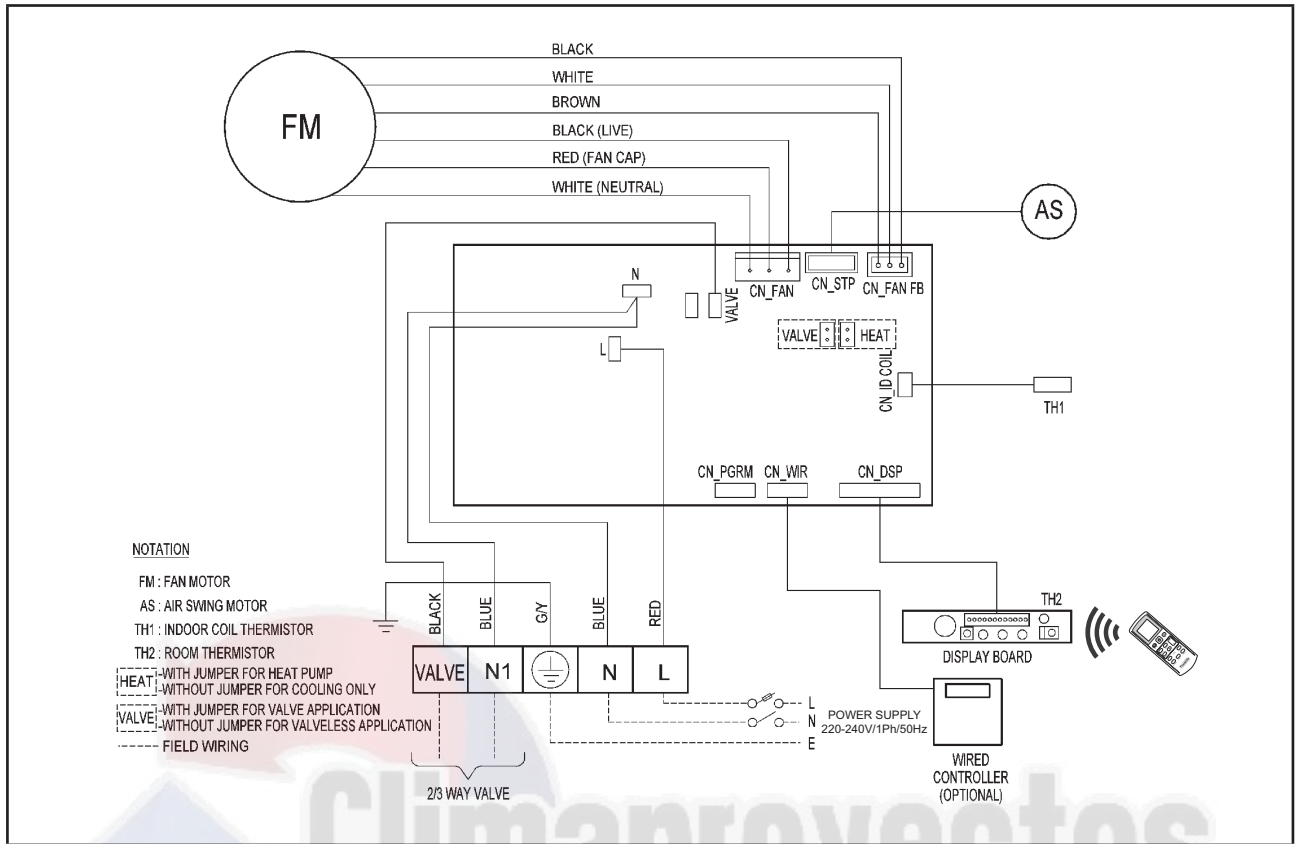

Model: FWKE05/08E

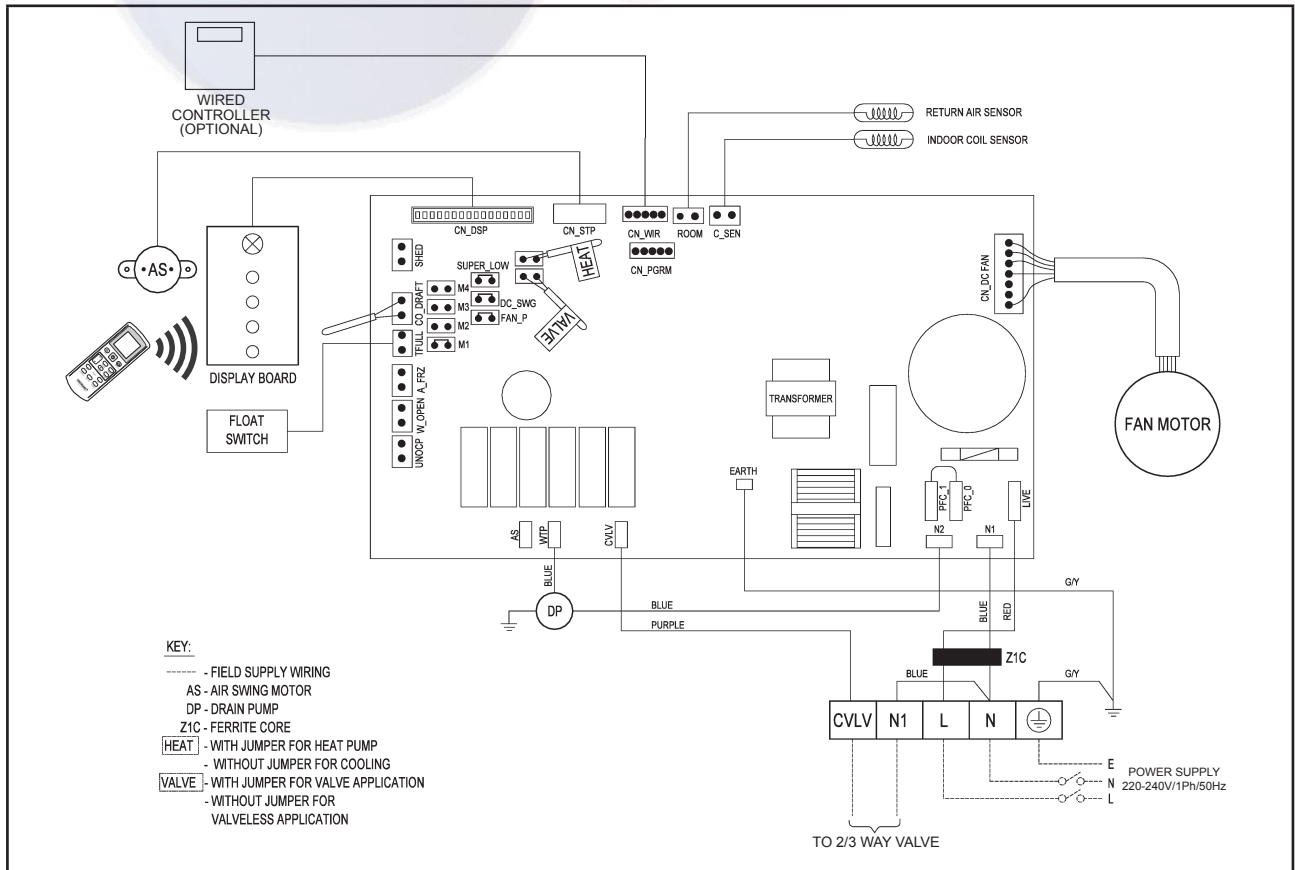



Model: FWKE11E

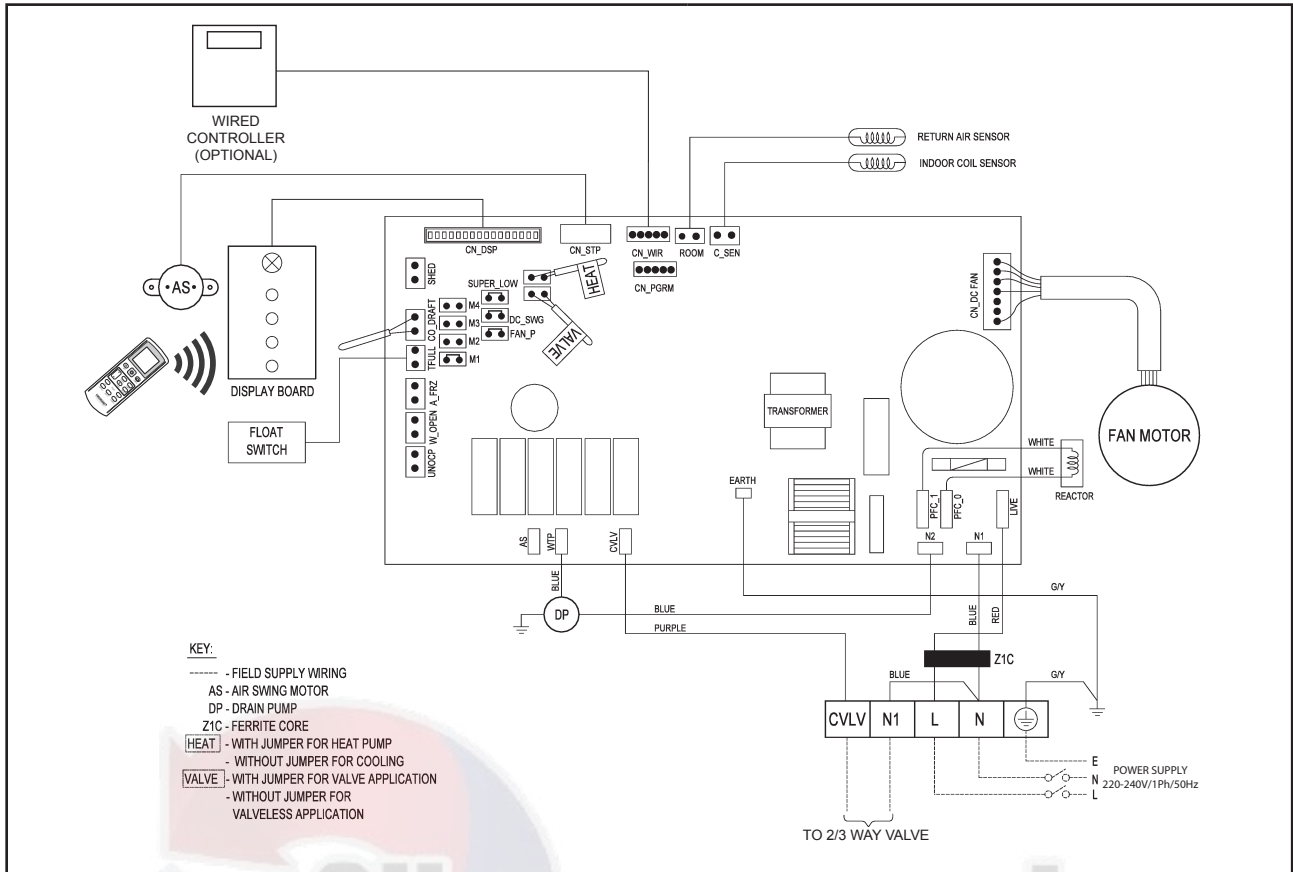

Model: FWKE05/08EH

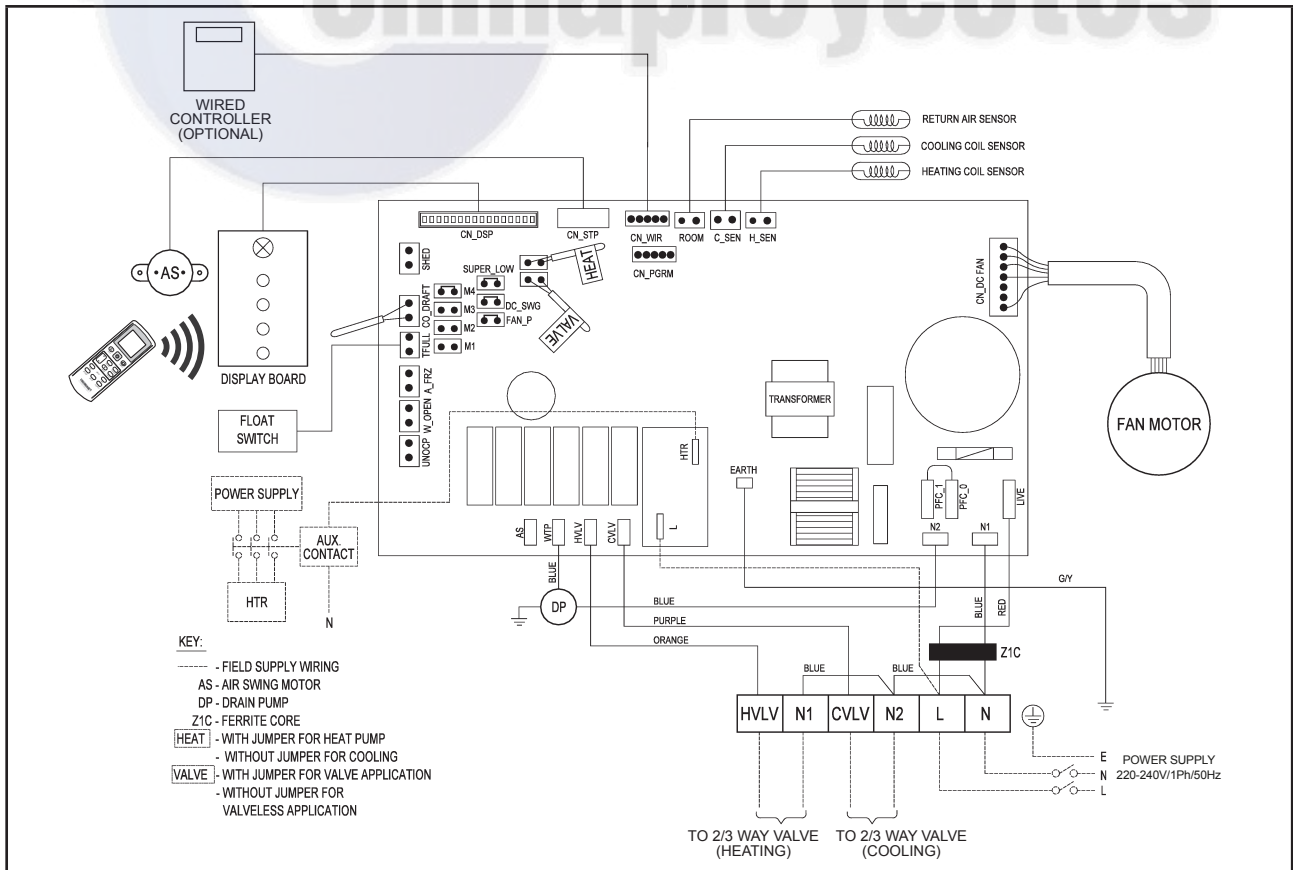

Model: FWKE11EH

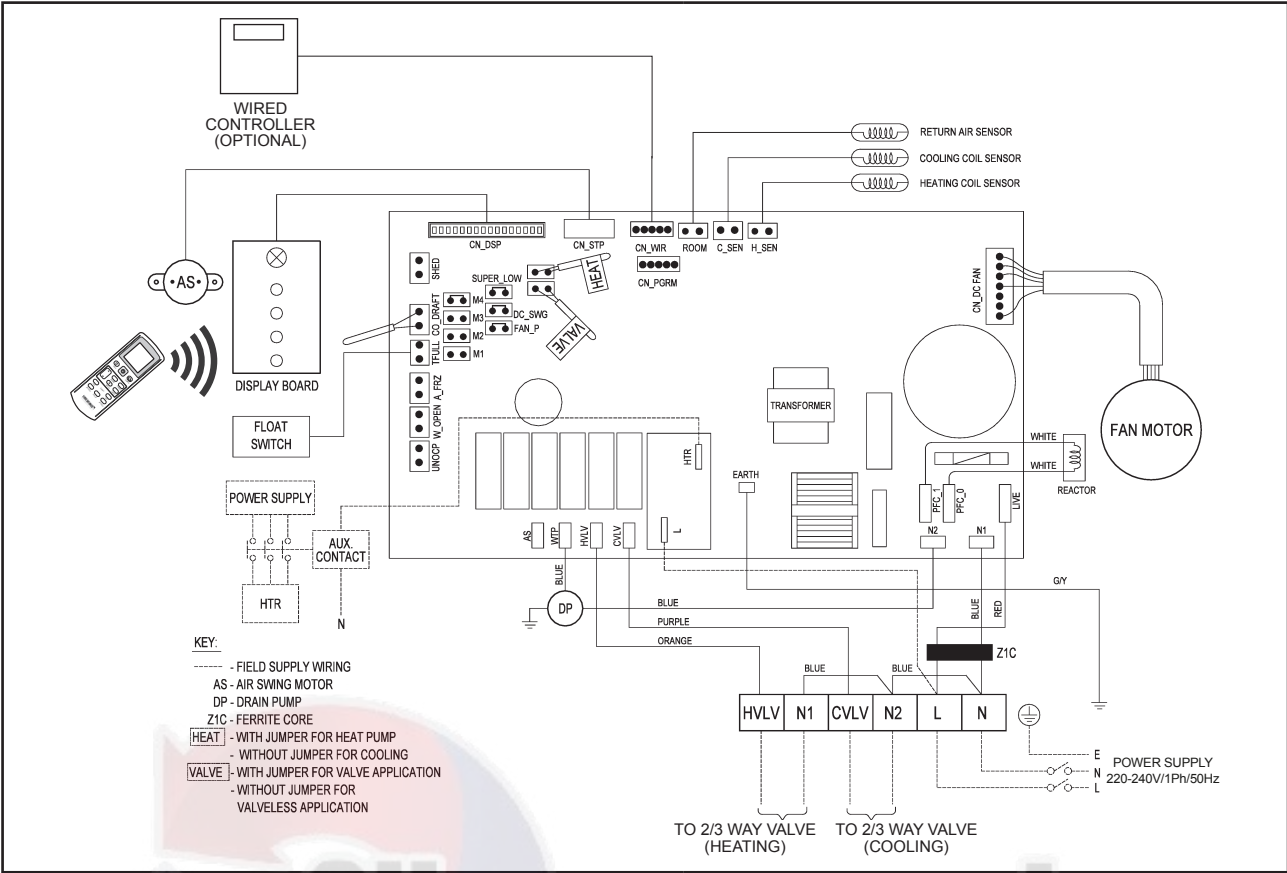

Model: FWC03/04/06/07C (With Controller)

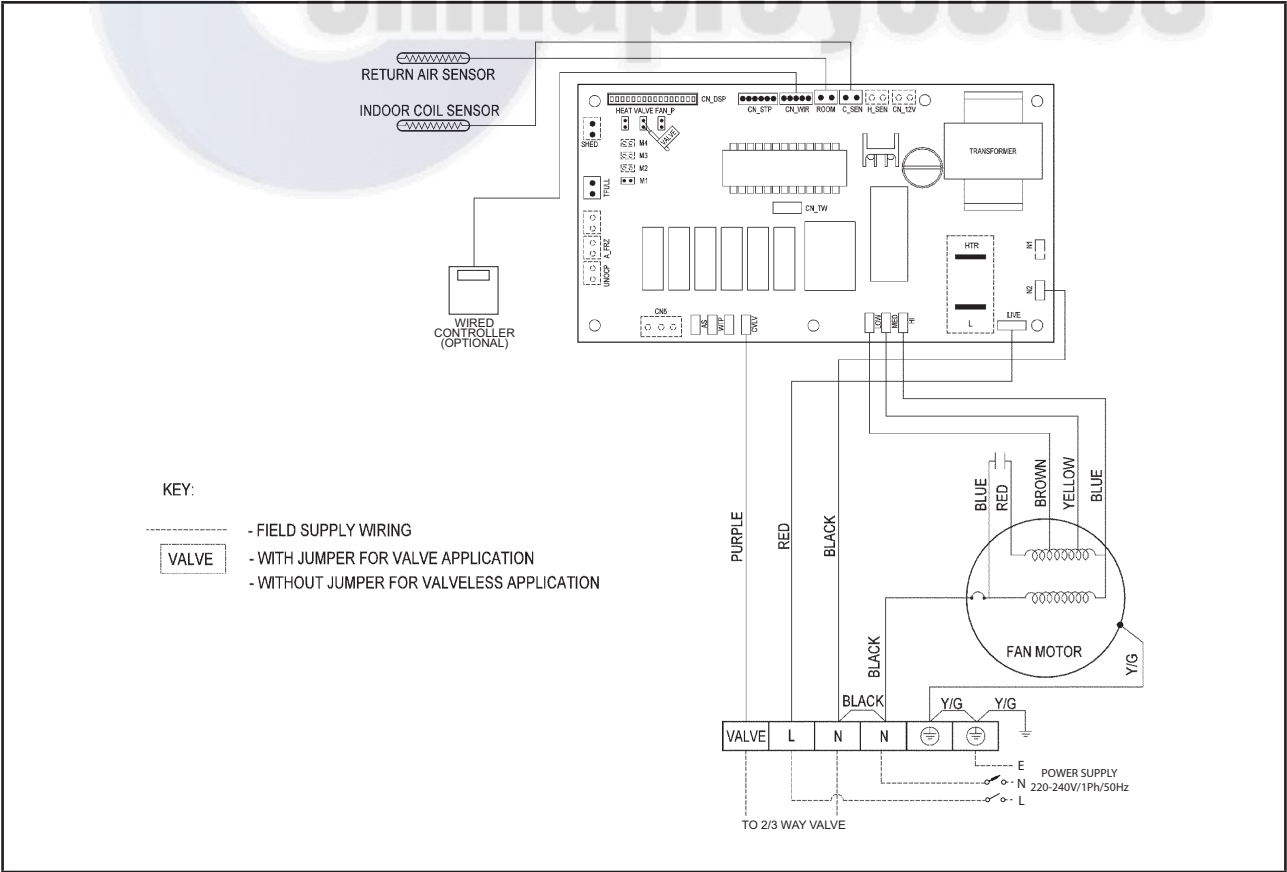

Model: FWC09/12/14/16C (With Controller)

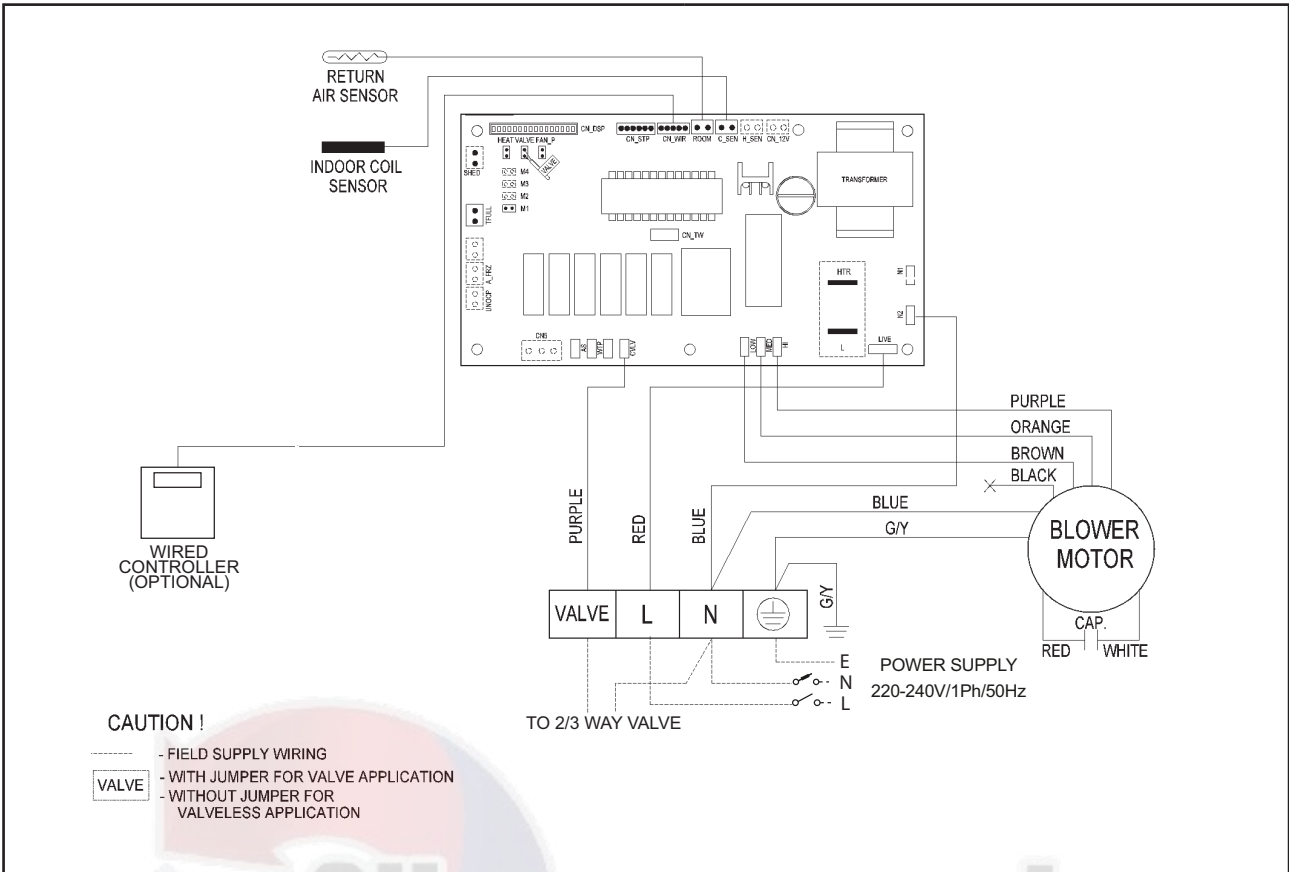

Model: FWC03/04/06/07C (Without Controller)

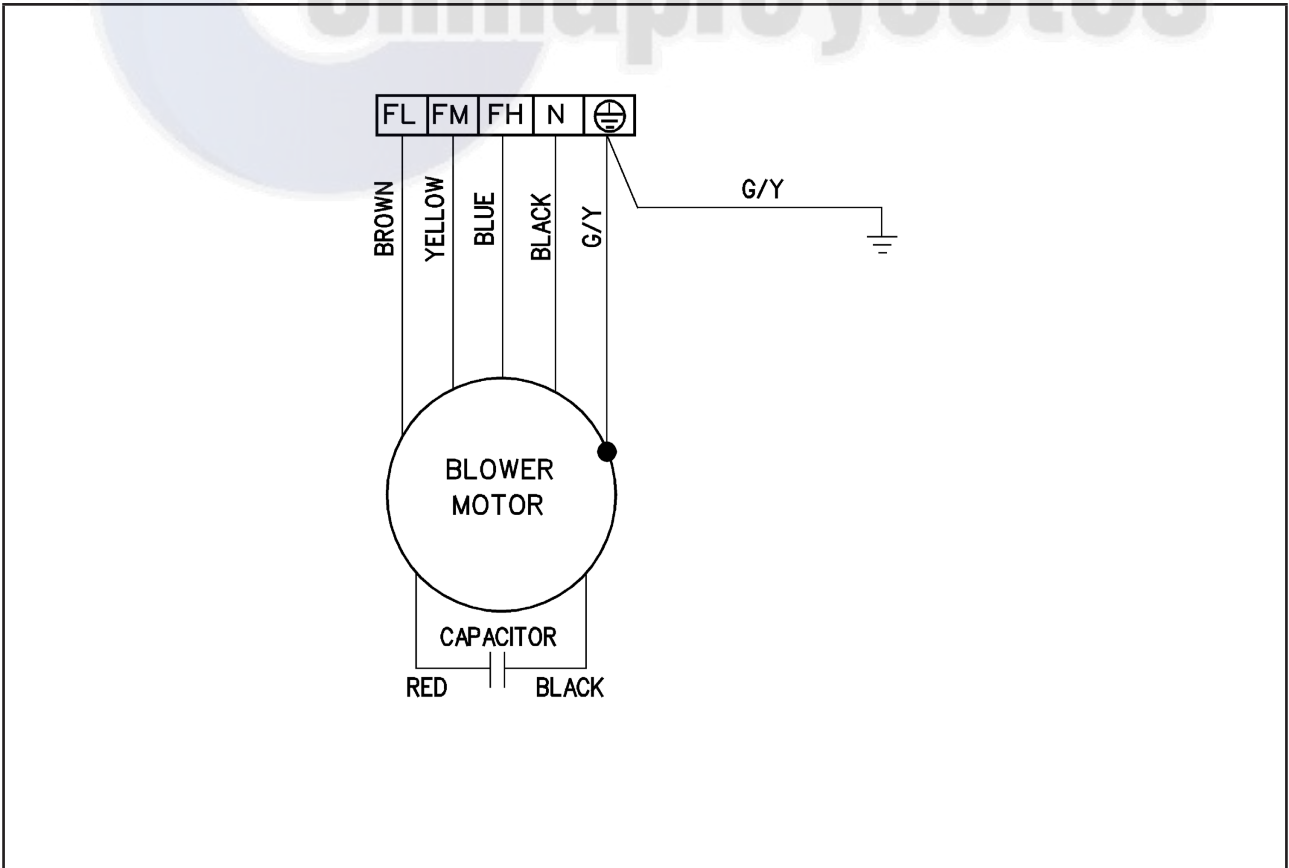

Model: FWC09/12/14/16C (Without Controller)

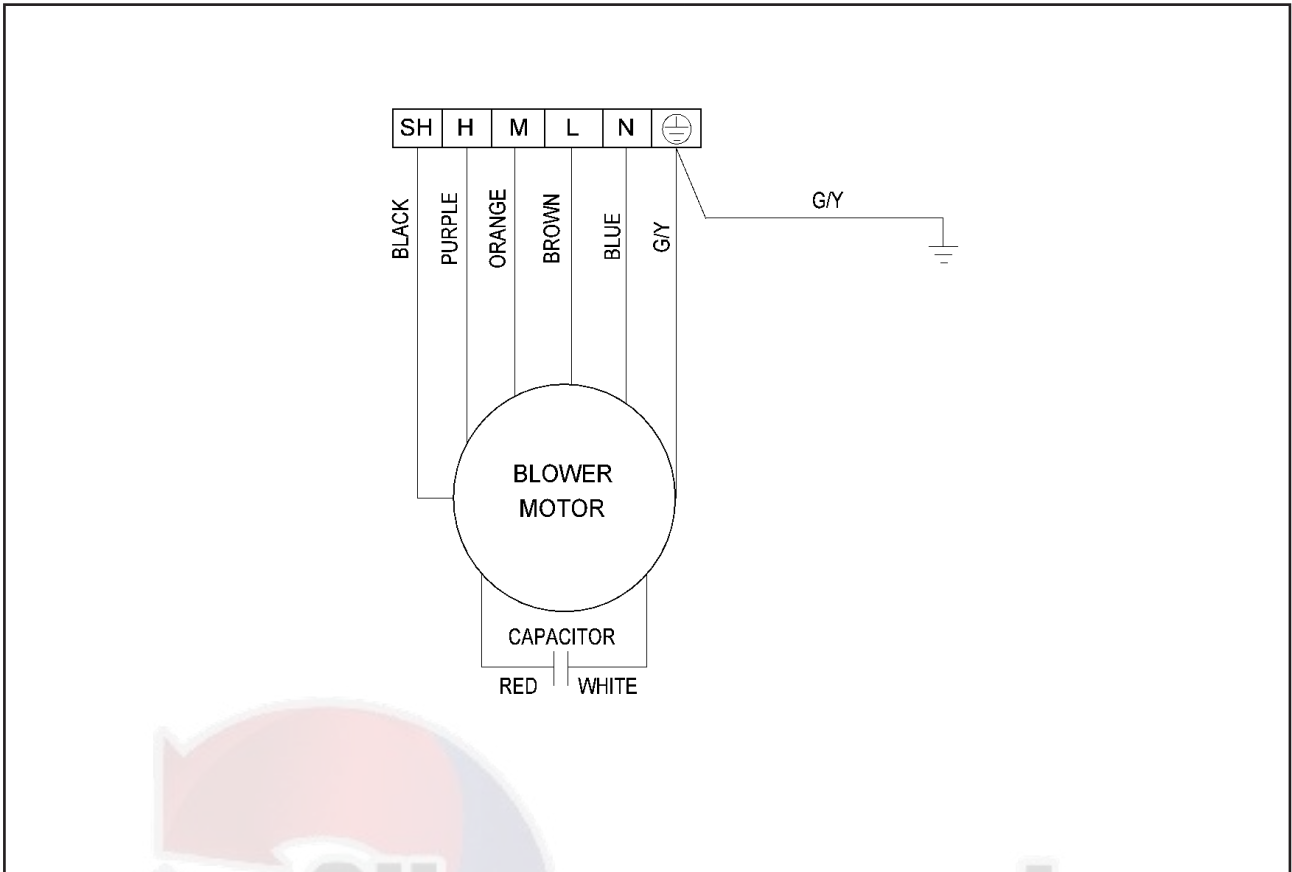

Model: FWC03/04/06/14/16/18/20G (MSP)

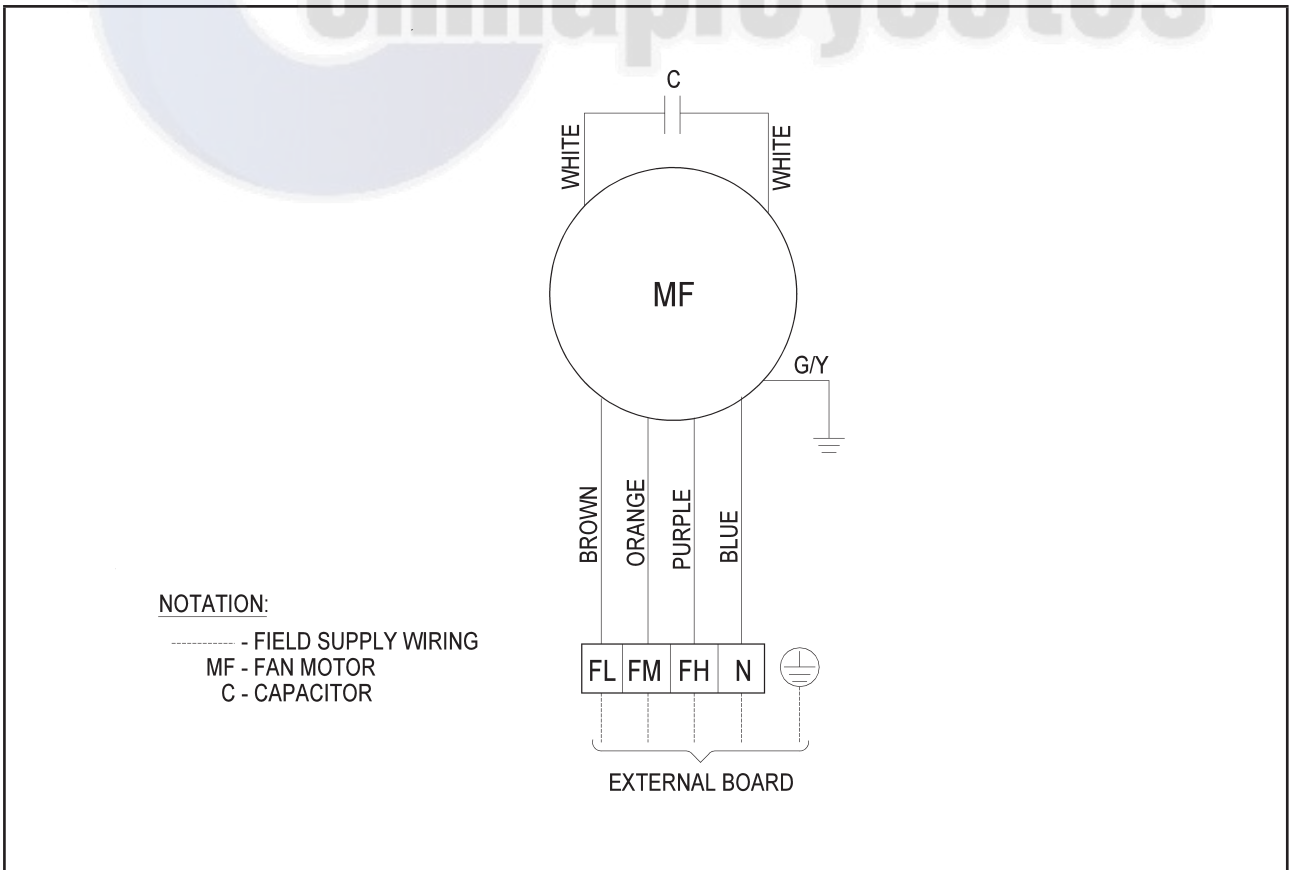

Model: FWC08/10/12G (MSP)

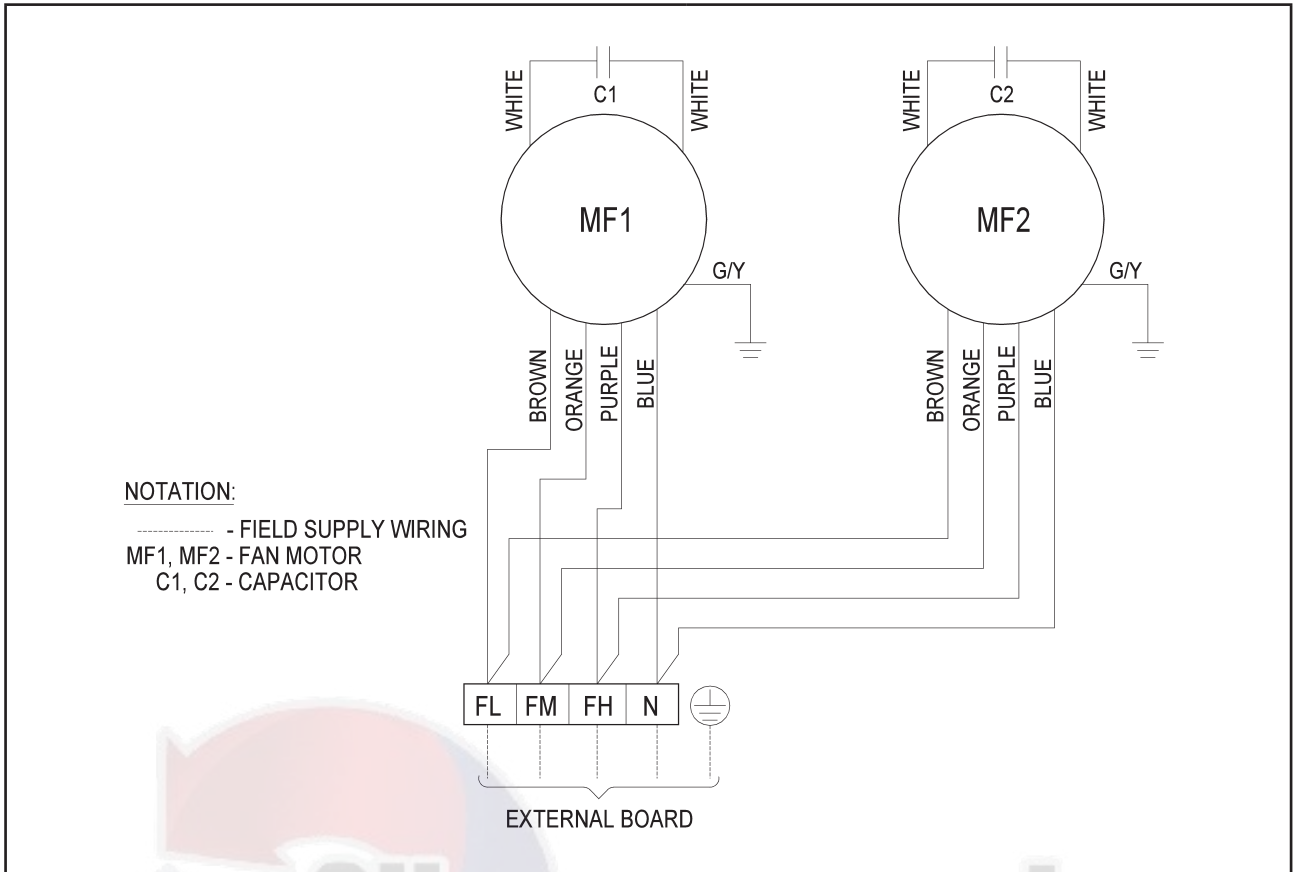

Model: FWC02/03/04/06/08/12G EC (LSP , MSP)

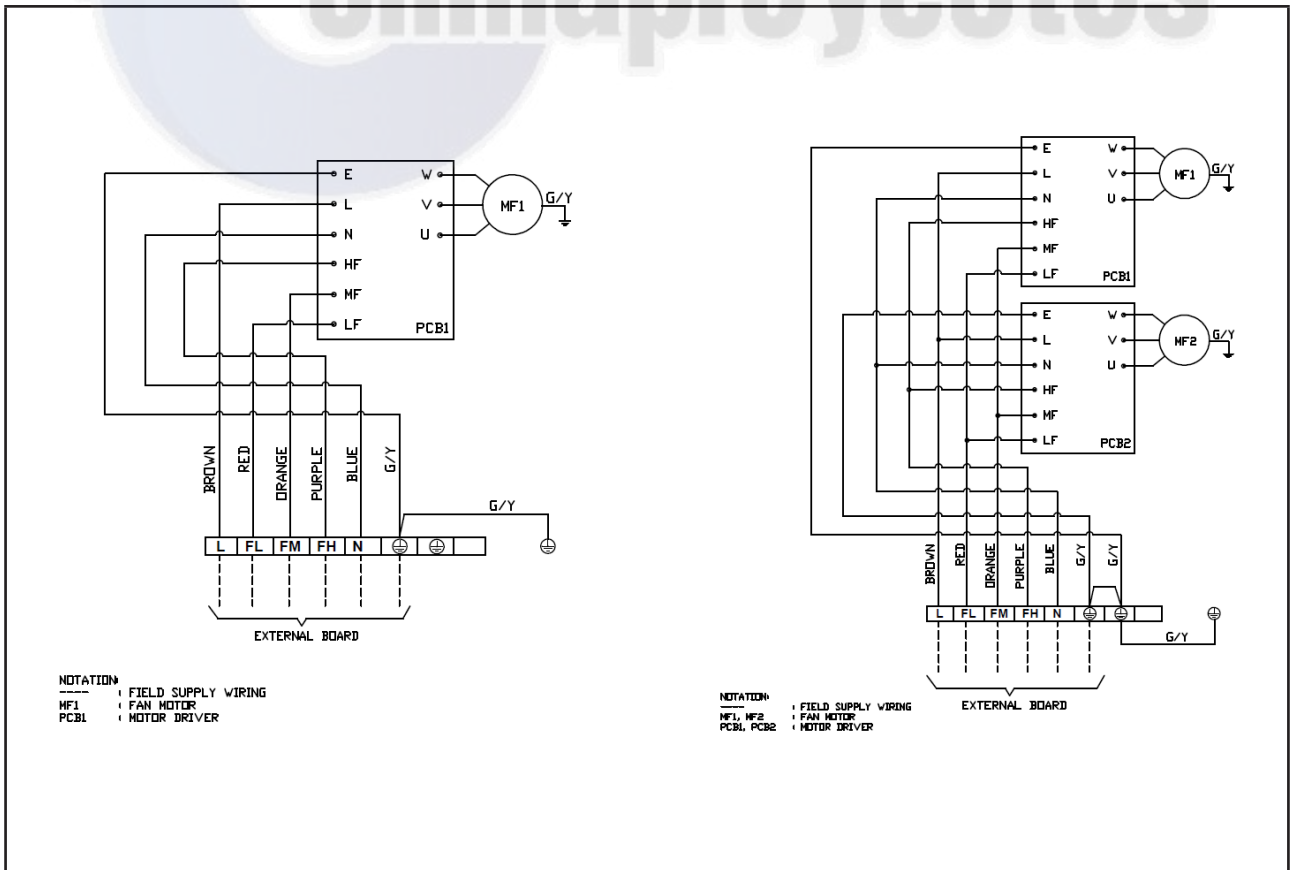

Model: FUD20B

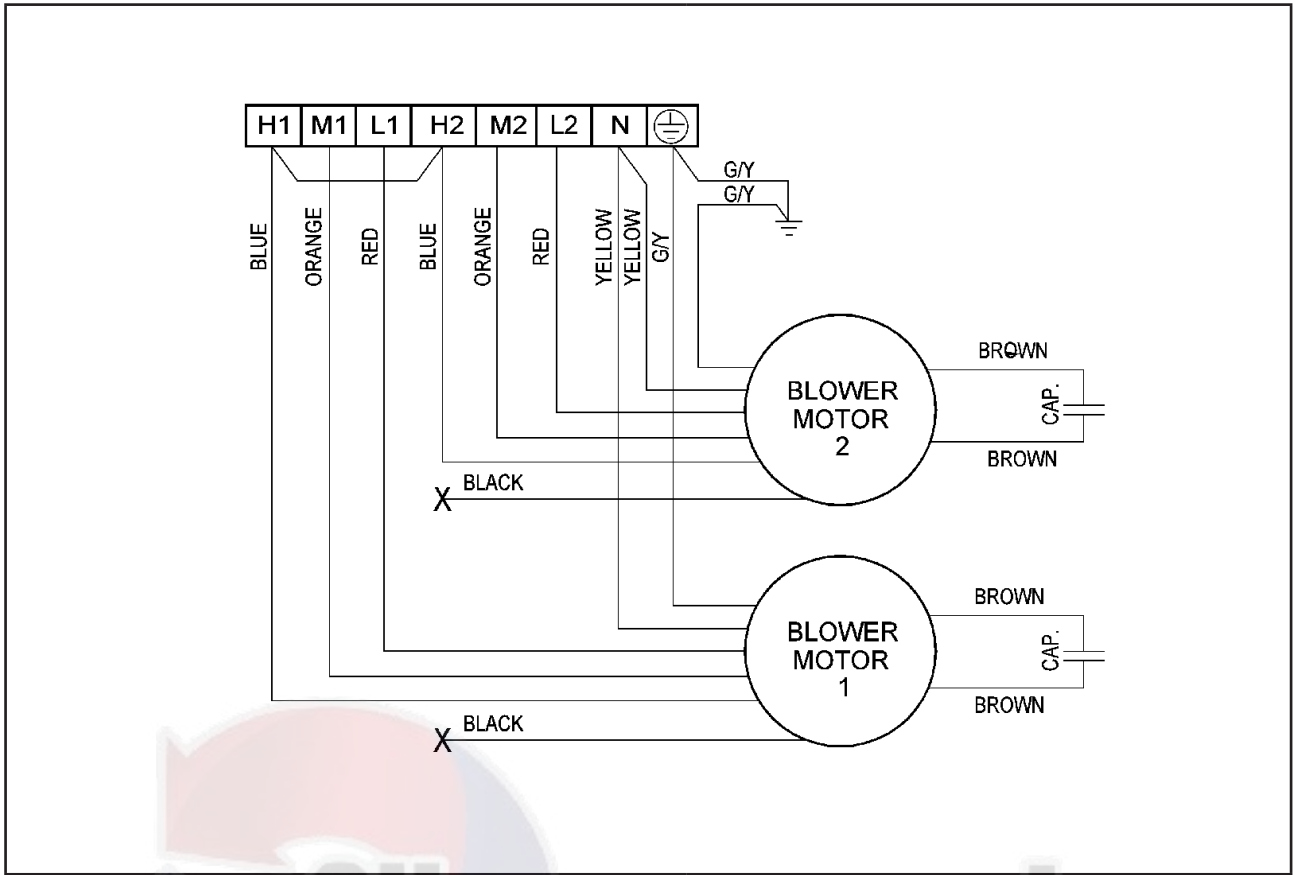

Model: FUD25B

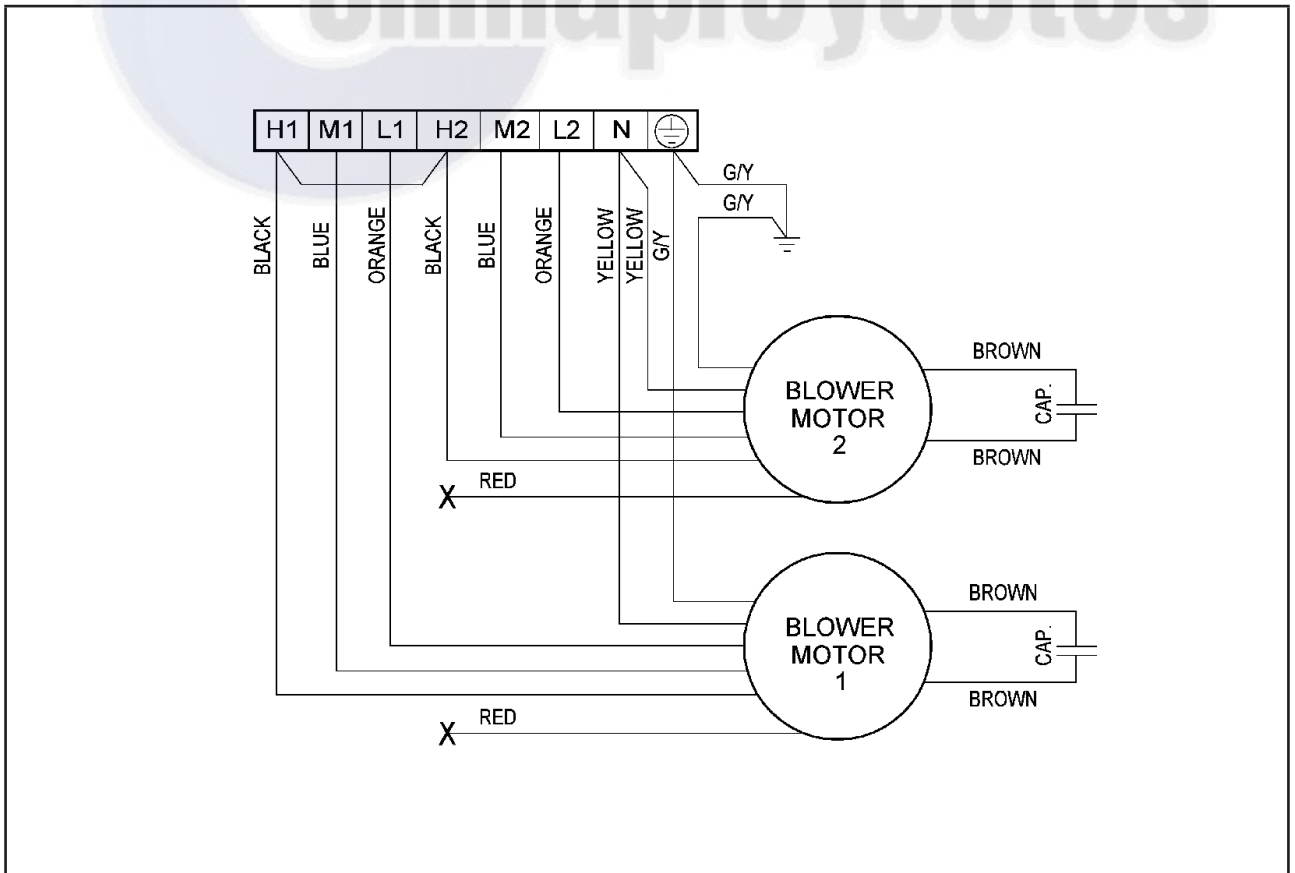

Model: FUD30B

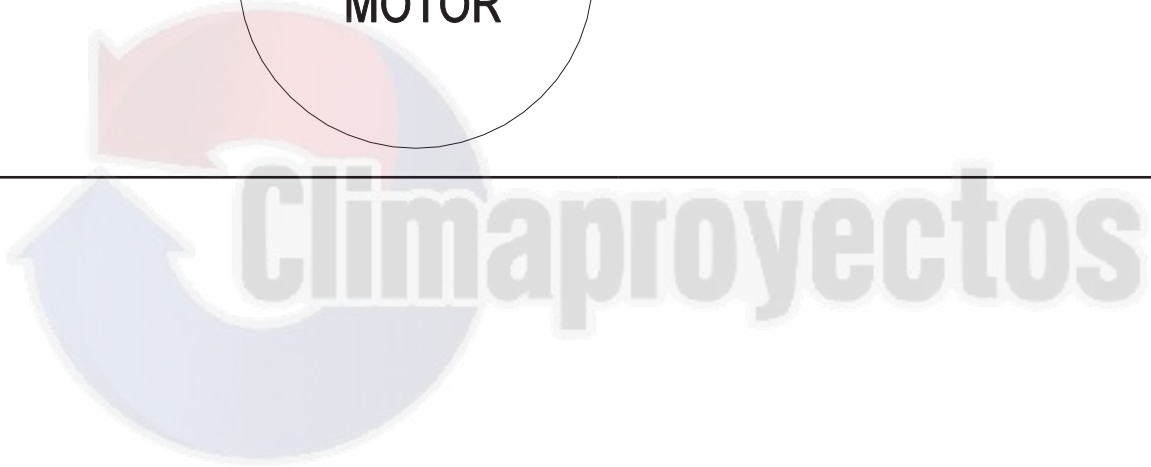
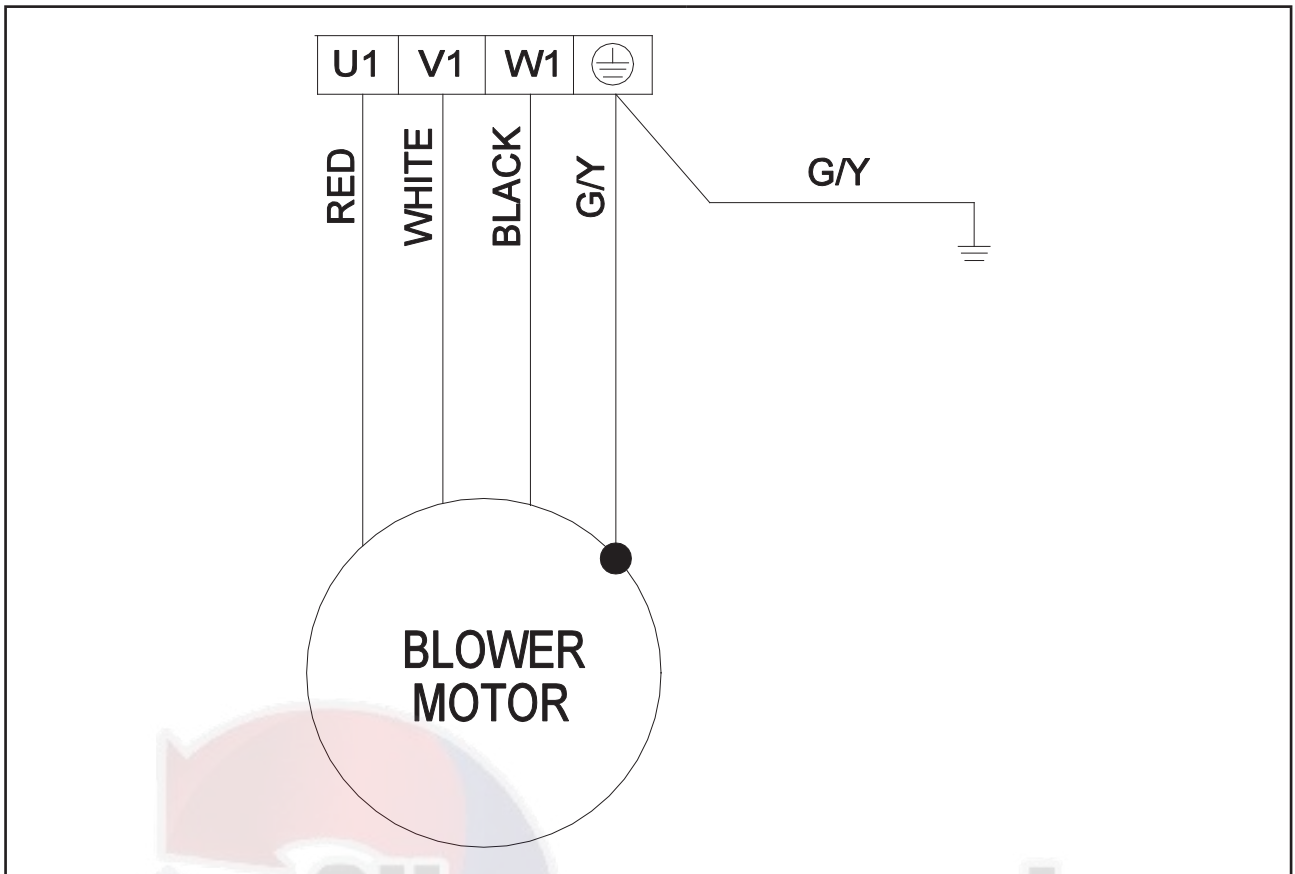

# Service & Maintenance



## Caution

Moving machinery and electrical power hazards. May cause severe personal injury or death. Disconnect from main power supply before servicing equipment.

The unit is designed to give long life operation with minimum maintenance required. However, it should be regularly checked and the following items should be given due attention.

Components	Maintenance Procedures	Recommended Schedule
Air Filter (Indoor Unit)	<ol style="list-style-type: none"> <li>1. Remove any dust adhering to the filter by using a vacuum cleaner or wash in lukewarm water (below 40°C) with a neutral cleaning detergent.</li> <li>2. Rinse the filter well and dry before placing it back onto the unit.</li> <li>3. Note: Never use gasoline, volatile substances or chemicals to clean the filter.</li> </ol>	<p>At least once every 4 weeks.</p> <p>More frequently if necessary.</p>
Indoor Unit	<ol style="list-style-type: none"> <li>1. Clean any dirt or dust on the grille or panel by wiping it with a soft cloth soaked in lukewarm water (below 40°C) and a neutral detergent solution.</li> <li>2. Note: Never use gasoline, volatile substances or chemicals to clean the indoor unit.</li> </ol>	<p>At least once every 4 weeks.</p> <p>More frequently if necessary.</p>
Condense Drain Pan & Pipe	<ol style="list-style-type: none"> <li>1. Check the cleanliness and clean it if necessary.</li> </ol>	Every 3 months.
Indoor Fan	Check if there is any abnormal noise.	When necessary.
Indoor Coil	<ol style="list-style-type: none"> <li>1. Check and remove the dirt between the fins.</li> <li>2. Check and remove any obstacles which hinder air flowing into and out of the indoor unit.</li> </ol>	Every month.
Power Supply	<ol style="list-style-type: none"> <li>1. Check the voltage and current of the indoor unit.</li> <li>2. Check the electrical wiring for any faulty contacts caused by loose connections, foreign matters, etc. Tighten the wires onto the terminal block if necessary.</li> </ol>	Every 2 months.
Fan Motor Oil	All motors are pre-lubricated and sealed at factory.	No maintenance required.



## Caution





















Do not charge **OXYGEN, ACETYLENE OR OTHER FLAMMABLE** and poisonous gases into the unit when performing a leakage test or an air tight test. These gases could cause severe explosion and damage if expose to high temperature and pressure.



# Troubleshooting

Model	Board
FWW03/04/05/06L	50WJW
FWKE05/08/11E(H)	W3DC
FWC03/04/06/07/09/12/14/16C	W2
FWC03/04/06/08/10/12/14/16/18/20G	No Controller
FWC02/03/04/06/08/10/12G EC	No Controller
FUD20/25/30B	No Controller

## Self Diagnostic Table - 50WJW Board

	 COOL/HEAT (GREEN/RED)		Normal Operation/Fault Indication	Action	Error Code
	 Green		Cool mode	-	-
	 Red		Heat mode	-	-
			Timer on	-	-
			Sleep mode on	-	-
			Fan mode on	-	-
			Dry mode on	-	-
	 1 time		Room air sensor contact Loose/Short	Call your dealer	Blink E1
	 2 times		Indoor coil sensor open/short	Call your dealer	Blink E2
		 3 times	Pipe water temperature poor	-	Blink E4
		 1 time	Pipe water temperature bad	-	Blink E5
		 6 times	Hardware error (tact switch pin short)	Call your dealer	Blink E8
	 4 times		No feedback from indoor fan	Call your dealer	Blink E9

 ON

 ON or OFF

 Blinking

### Self Diagnostic Table – W3 Board

	Event	Power LED	Timer LED	Error Code
1.	Room Sensor Open or Short	Blink 1 time	-	Blink E1
2.	Pipe Water sensor Open or Short	Blink 2 times	-	Blink E2
3.	Pipe Water Temperature poor	Blink 3 times	-	Blink E4
4.	Pipe Water Temperature bad/fault	-	Blink 1 time	Blink E5
5.	Water Pump Fault**	-	Blink 2 times	Blink E6
6.	Hardware Error (tact switch pin Short/M3 or M4 Mode with valveless section)	-	Blink 6 times	Blink E8
7.	Window Open activated*	Blink 6 times	-	-
8.	Antifreeze mode activated*	Blink 7 times	-	-
9.	Load Shedding activated*	Blink 8 times	-	-

\*Only applicable for 4-pipes system.

\*\*Applicable to FWK model only.

### Self Diagnostic Table – W3DC Board

	Event	Power LED	Timer LED	Error Code
1.	Room Sensor Open or Short	Blink 1 time	-	Blink E1
2.	Pipe Water sensor Open or Short	Blink 2 times	-	Blink E2
3.	Pipe Water Temperature poor	Blink 3 times	-	Blink E4
4.	Pipe Water Temperature bad/fault	-	Blink 1 time	Blink E5
5.	Water Pump Fault	-	Blink 2 times	Blink E6
6.	Window Open activated*	Blink Cool 6 times	-	-
7.	Antifreeze mode activated*	Blink Cool 7 times	-	-
8.	Load Shedding activated*	Blink Cool 8 times	-	-
9.	Hardware Error	-	Blink 6 times	Blink E8
10.	No feedback from indoor fan	Blink Cool 4 times		Blink E9

\*Only applicable for 4-pipes system.

