



WeatherExpert®
50LC14-26 Single Package Rooftop
Cooling Only
with Puron® (R-410A) Refrigerant

Installation Instructions

CONTENTS

	Page
SAFETY CONSIDERATIONS	1
MODEL NUMBER NOMENCLATURE AND DIMENSIONS	2
Rated Indoor Airflow	2
INSTALLATION	19
Jobsite Survey	19
Step 1 — Plan for Unit Location	19
• ROOF MOUNT	
Step 2 — Plan for Sequence of Unit Installation ..	19
• CURB-MOUNTED INSTALLATION	
• PAD-MOUNTED INSTALLATION	
• FRAME-MOUNTED INSTALLATION	
Step 3 — Inspect Unit	19
Step 4 — Provide Unit Support	19
• ROOF CURB MOUNT	
• SLAB MOUNT (HORIZONTAL UNITS ONLY)	
• ALTERNATE UNIT SUPPORT (IN LIEU OF CURB OR SLAB MOUNT)	
Step 5 — Field Fabricate Ductwork	24
• UNITS WITH ACCESSORY OR OPTIONAL ELECTRIC HEATERS	
Step 6 — Rig and Place Unit	24
• POSITIONING ON CURB	
Step 7 — Horizontal Duct Connection	25
Step 8 — Install Outside Air Hood (Factory Option) .	25
Step 9 — Assemble Barometric Hood	26
• BAROMETRIC HOOD (VERTICAL CONFIGURATION)	
• BAROMETRIC HOOD (HORIZONTAL CONFIGURATION)	
Step 10 — Economizer – Horizontal Airflow Units ..	28
Step 11 — Install External Condensate Trap/Line ...	28
Step 12 — Make Electrical Connections	28
• FIELD POWER SUPPLY	
• UNITS WITHOUT FACTORY-INSTALLED NON-FUSED DISCONNECT OR HACR	
• UNITS WITH FACTORY-INSTALLED NON-FUSED DISCONNECT OR HACR	
• ALL UNITS	
• CONVENIENCE OUTLETS	
• HACR AMP RATING	
• FACTORY-OPTION THRU-BASE ELECTRICAL CONNECTIONS	
• UNITS WITHOUT THRU-BASE ELECTRICAL CONNECTIONS	
• FIELD CONTROL WIRING	
• THERMOSTAT	
• UNITS WITHOUT THRU-BASE CONNECTION KIT	
• CONFIGURING FOR ELECTRIC HEAT	
• HEAT ANTICIPATOR SETTINGS	
• TRANSFORMER CONNECTION FOR 208-V POWER SUPPLY	

• ELECTRIC HEATERS	
• HUMIDIFIER® SYSTEM CONTROL CONNECTIONS	
RTU Open Controller (Factory-Installed Option) ..	43
SystemVu Controller (Factory-Installed Option) ...	43
Integrated Staging Control (ISC)	44
• SEQUENCE OF OPERATION	
Economizer® X (Factory-Installed Option)	46
• UNIT INSTALLATION	
• ENTHALPY SENSOR RELOCATION	
• W7220 ECONOMIZER CONTROLLER	
• W7220 ECONOMIZER MODULE WIRING	
• ECONOMIZER CONTROL CONFIGURATIONS	
• ECONOMIZER HARDWARE	
• OPERATING SEQUENCES	
• W7220 ECONOMIZER SETUP AND CONFIGURATION	
• TROUBLESHOOTING	
• CONTROL SETPOINT AND CONFIGURATION LOG	
Staged Air Volume (SAV™) with Variable Frequency Drive	66
• MULTI-SPEED VFD DISPLAY KIT (FIELD-INSTALLED ACCESSORY)	
Smoke Detectors	78
• RETURN AIR SENSOR TUBE INSTALLATION	
• SMOKE DETECTOR TEST MAGNET	
• ADDITIONAL APPLICATION DATA	
Step 13 — Install Accessories	78
Step 14 — Check Belt Tension	78
• BELT FORCE: DEFLECTION METHOD	
Pre-Start and Start-Up	79
START-UP CHECKLIST	CL-1

SAFETY CONSIDERATIONS

Installation and servicing of air-conditioning equipment can be hazardous due to system pressure and electrical components. Only trained and qualified service personnel should install, repair, or service air-conditioning equipment.

Untrained personnel can perform basic maintenance functions of cleaning coils and filters and replacing filters. All other operations should be performed by trained service personnel. When working on air-conditioning equipment, observe precautions in the literature, tags and labels attached to the unit, and other safety precautions that may apply.

Follow all safety codes, including ANSI (American National Standards Institute) Z223.1. Wear safety glasses and work gloves. Use quenching cloth for unbrazing operations. Have fire extinguisher available for all brazing operations.

It is important to recognize safety information. This is the safety-alert symbol . When you see this symbol on the unit and in instructions or manuals, be alert to the potential for personal injury.

Understand the signal words DANGER, WARNING, CAUTION, and NOTE. These words are used with the safety-alert symbol. DANGER identifies the most serious hazards which **will** result in severe personal injury or death. WARNING signifies hazards which **could** result in personal injury or death. CAUTION is used to identify unsafe practices, which **may** result in minor personal injury or product and property damage. NOTE is used to highlight suggestions which **will** result in enhanced installation, reliability, or operation.

⚠ WARNING

Electrical shock can cause personal injury and death. Shut off all power to this equipment during installation. There may be more than one disconnect switch. Tag all disconnect locations to alert others not to restore power until work is completed.

⚠ WARNING

UNIT OPERATION AND SAFETY HAZARD

Failure to follow this warning could cause personal injury, death and/or equipment damage.

R-410A refrigerant systems operate at higher pressures than standard R-22 systems. Do not use R-22 service equipment or components on R-410A refrigerant equipment.

⚠ WARNING

PERSONAL INJURY AND ENVIRONMENTAL HAZARD

Failure to follow this warning could cause personal injury or death.

Relieve pressure and recover all refrigerant before system repair or final unit disposal.

Wear safety glasses and gloves when handling refrigerants. Keep torches and other ignition sources away from refrigerants and oils.

⚠ CAUTION

PERSONAL INJURY HAZARD

Failure to follow this caution may result in personal injury.

Sheet metal parts may have sharp edges or burrs. Use care and wear appropriate protective clothing, safety glasses and gloves when handling parts and servicing air conditioning equipment.

MODEL NUMBER NOMENCLATURE AND DIMENSIONS

See Fig. 1 for 50LC model number nomenclature. See Fig. 2-16 for unit dimensional drawings. Figures 5, 10, and 15 show service clearance dimensions.

Rated Indoor Airflow

Table 1 lists the rated indoor airflow used for the AHRI efficiency rating for the units covered in this document. See Table 2 for unit operating weights.

Table 1 — Rated Indoor Airflow

MODEL NUMBER	FULL LOAD AIRFLOW (CFM)
50LC**14	4375
50LC**17	4875
50LC**20	5690
50LC**24	6500
50LC**26	7500

Position:	1	2	3	4	5	6	7	8	9	10	11	12	13	14	15	16	17	18
Example:	5	0	L	C	D	0	2	4	A	1	A	5	-	0	A	0	A	0

Unit Heat Type

50 - Electric Cooling
Packaged Rooftop

Model Series - WeatherExpert®

LC - Ultra High Efficiency

Heat Options

0 = Standard - No Electric Heat
D = Low Electric Heat
E = Medium Electric Heat
F = High Electric Heat

Refrig. Systems Options

0 = Three stage cooling capacity control with TXV
A = Three stage cooling capacity control with TXV and Humidi-MiZer® system

Cooling Tons

14 - 12.5 ton
17 - 15 ton
20 - 17.5 ton
24 - 20 ton
26 - 23 ton

Sensor Options

A = None
B = RA Smoke Detector
C = SA Smoke Detector
D = RA + SA Smoke Detector
E = CO₂
F = RA Smoke Detector and CO₂
G = SA Smoke Detector and CO₂
H = RA + SA Smoke Detector and CO₂

Indoor Fan Motor Options

1 = Standard Static / Vertical Supply, Return Air Flow
2 = Medium Static / Vertical Supply, Return Air Flow
3 = High Static / Vertical Supply, Return Air Flow
4 = Ultra High Static / Vertical Supply, Return Air Flow
5 = Standard Static / Horizontal Supply, Return Air Flow
6 = Medium Static / Horizontal Supply, Return Air Flow
7 = High Static / Horizontal Supply, Return Air Flow
8 = Ultra High Static / Horizontal Supply, Return Air Flow

Coil Options: Fin/Tube (Condenser- Evaporator - Hail Guard)

A = Al/Cu - Al/Cu
B = Precoat Al/Cu - Al/Cu
C = E-coat Al/Cu - Al/Cu
D = E-coat Al/Cu - E-coat Al/Cu
E = Cu/Cu - Al/Cu
F = Cu/Cu - Cu/Cu
M = Al/Cu -Al/Cu — Louvered Hail Guard
N = Precoat Al/Cu - Al/Cu — Louvered Hail Guard
P = E-coat Al/Cu - Al/Cu — Louvered Hail Guard
Q = E-coat Al/Cu - E-coat Al/Cu — Louvered Hail Guard
R = Cu/Cu - Al/Cu — Louvered Hail Guard
S = Cu/Cu - Cu/Cu — Louvered Hail Guard

Packaging

0 = Standard
1 = LTL

Electrical Options

A = None
B = HACR Circuit Breaker
C = Non-Fused Disconnect

Service Options

0 = None
1 = Unpowered Convenience Outlet
2 = Powered Convenience Outlet
3 = Hinged Panels
4 = Hinged Panels and Unpowered Convenience Outlet
5 = Hinged Panels and Powered Convenience Outlet

Intake / Exhaust Options

A = None
B = Temperature Standard Leak Economizer with Barometric Relief
C = Temperature Standard Leak Economizer with Centrifugal Power Exhaust - Vertical Only
E = Enthalpy Standard Leak Economizer with Barometric Relief
F = Enthalpy Standard Leak Economizer with Centrifugal Power Exhaust - Vertical Only
N = Temperature Ultra Low Leak Economizer with Barometric Relief
P = Temperature Ultra Low Leak Economizer with Centrifugal Power Exhaust - Vertical Only
R = Enthalpy Ultra Low Leak Economizer with Barometric Relief
S = Enthalpy Ultra Low Leak Economizer with Centrifugal Power Exhaust - Vertical Only

Base Unit Controls

0 = Electro-mechanical Controls
1 = RTU Open Multi-Protocol Controller
4 = SystemVu™ Controller

Design Revision

- = Factory Design Revision

Voltage

1 = 575/3/60
5 = 208-230/3/60
6 = 460/3/60

Fig. 1 — 50LC 14-26 Model Number Nomenclature (Example)

SUBMISSION OF THESE DRAWINGS OR DOCUMENTS DOES NOT CONSTITUTE PART PERFORMANCE OR ACCEPTANCE OF CONTRACT.

CONNECTION SIZES	
A	1 3/8" DIA [135] FIELD POWER SUPPLY KNOCKOUT
B	3" DIA [76] FIELD POWER SUPPLY KNOCKOUT
C	3 5/8" DIA [192] FIELD POWER SUPPLY KNOCKOUT
D	7/8" DIA [22] FIELD CONTROL WIRING HOLE
G	7/8" DIA [22] FIELD CONTROL WIRING KNOCKOUT

- NOTES:
1. DIMENSIONS ARE IN INCHES. DIMENSIONS IN [] ARE IN MILLIMETERS.
 2. CENTER OF GRAVITY
 3. DIRECTION OF AIR FLOW
 4. ALL VIEW DRAWN USING 3RD ANGLE

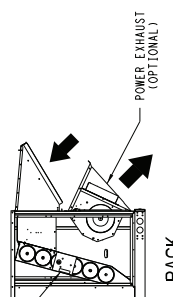
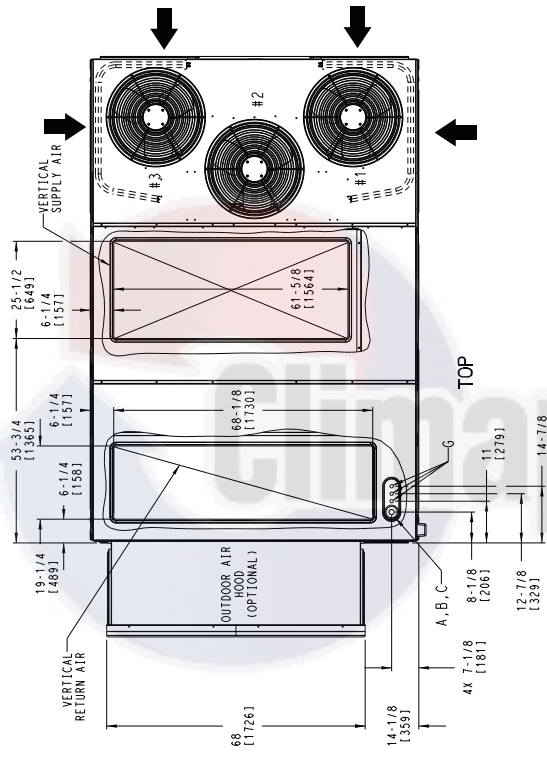

BACK
PANELS REMOVED TO SHOW ECONOMIZER AND POWER EXHAUST OPTIONS.

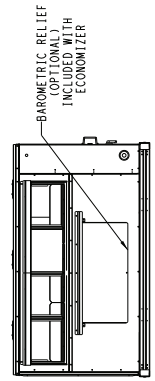

LEFT
SHOWN WITH THE BAROMETRIC RELIEF OPTION INSTALLED

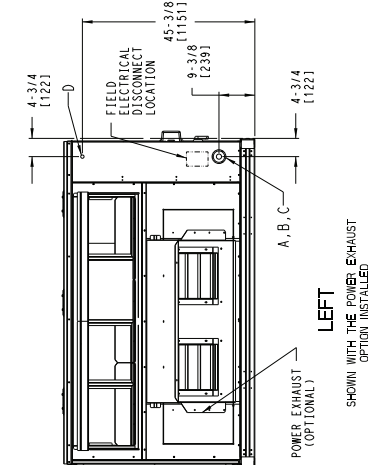

LEFT
SHOWN WITH THE POWER EXHAUST OPTION INSTALLED

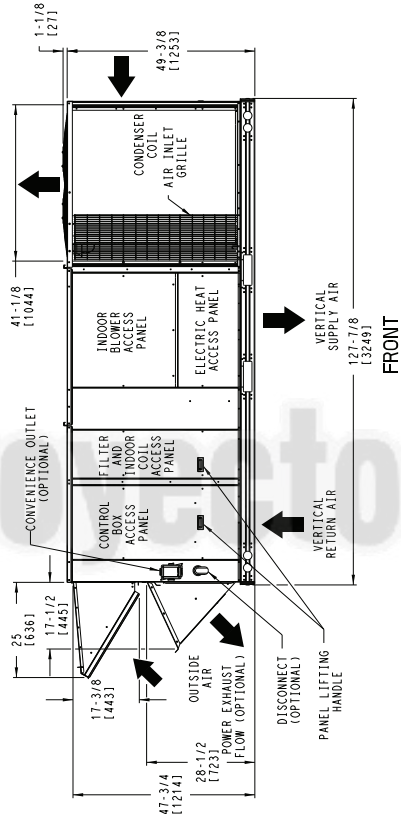

FRONT

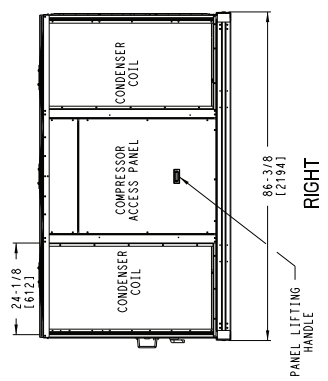

RIGHT

DEDICATED VERTICAL AIRFLOW UNIT

TIC CLASSIFICATION	SHEET	DATE	SUPERCEDES	REV
U.S. ECCN: NSR	1 OF 5	01/28/19	11/06/12	A

50LC 14 SINGLE ZONE ELECTRICAL COOLING WITH ELECTRIC HEAT

50LC500664

Fig. 2 — 50LC Vertical Airflow (Size 14)

SUBMISSION OF THESE DRAWINGS OR DOCUMENTS DOES NOT CONSTITUTE PART PERFORMANCE OR ACCEPTANCE OF CONTRACT.

CONNECTION SIZES	
A	1 3/8" DIA [35] FIELD POWER SUPPLY KNOCKOUT
B	3" DIA [76] FIELD POWER SUPPLY KNOCKOUT
C	3 5/8" DIA [92] FIELD POWER SUPPLY KNOCKOUT
D	7/8" DIA [22] FIELD CONTROL WIRING HOLE
G	7/8" DIA [22] FIELD CONTROL WIRING KNOCKOUT

NOTES:

1. DIMENSIONS ARE IN INCHES. DIMENSIONS IN [] ARE IN MILLIMETERS.
2. CENTER OF GRAVITY
3. DIRECTION OF AIR FLOW
4. ALL VIEW DRAWN USING 3RD ANGLE

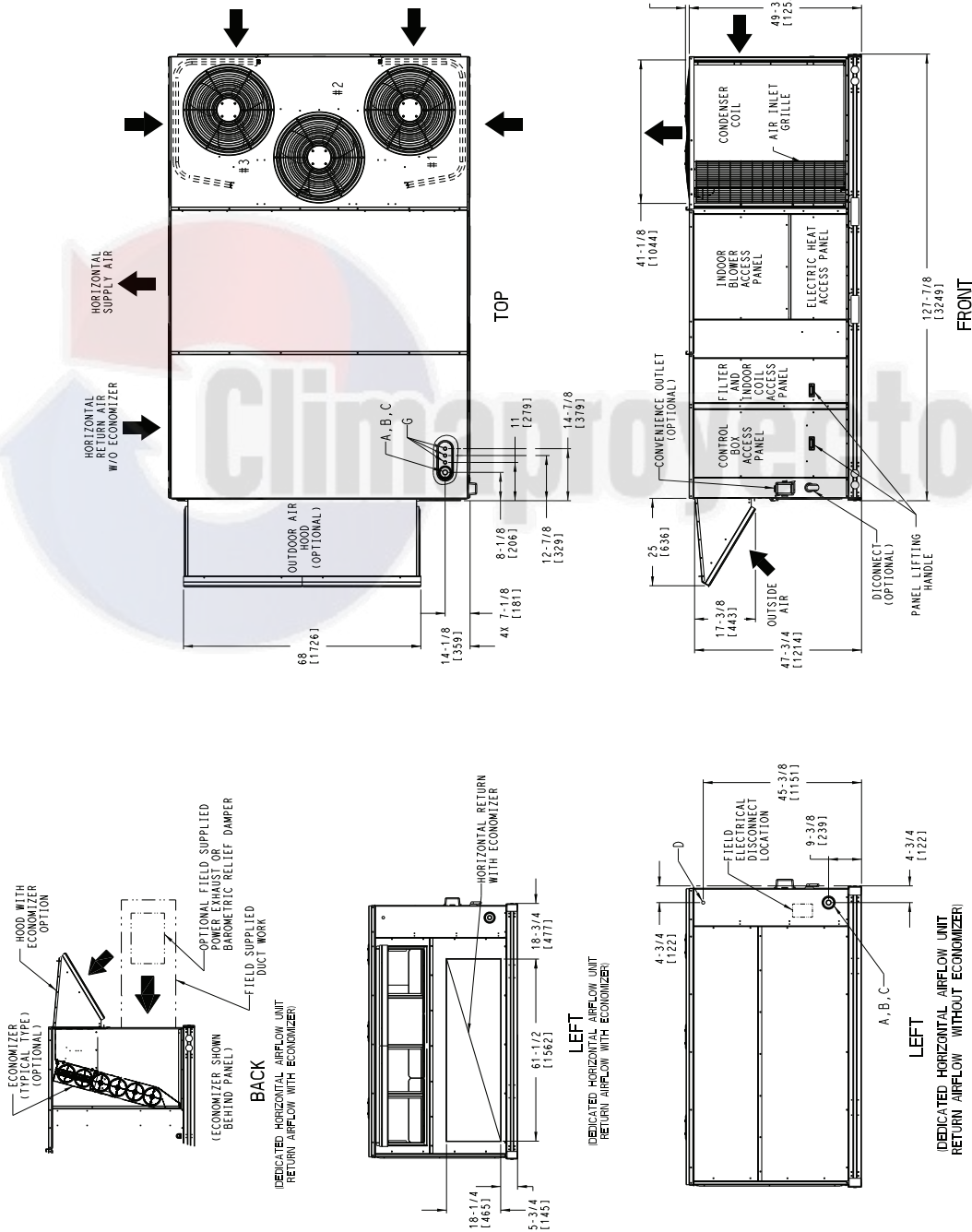

DEDICATED HORIZONTAL AIRFLOW UNIT

TIC CLASSIFICATION	SHEET	DATE	SUPERCEDES	REV
U.S. ECCN: -NSR	2 OF 5	01/28/19	11/06/12	A
50LC 14 SINGLE ZONE ELECTRICAL COOLING WITH ELECTRIC HEAT				50LC500664

Fig. 3 — 50LC Horizontal Airflow (Size 14)

SUBMISSION OF THESE DRAWINGS OR DOCUMENTS DOES NOT CONSTITUTE PART PERFORMANCE OR ACCEPTANCE OF CONTRACT.

CONNECTION SIZES	
E	3/4"-14 NPT CONDENSATE DRAIN

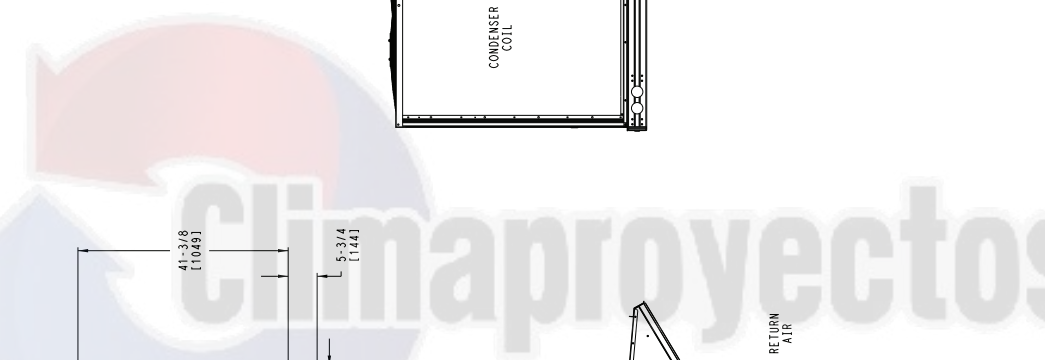
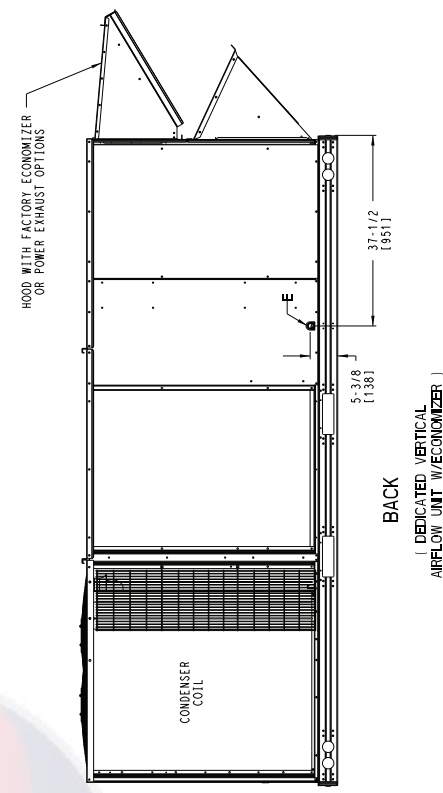
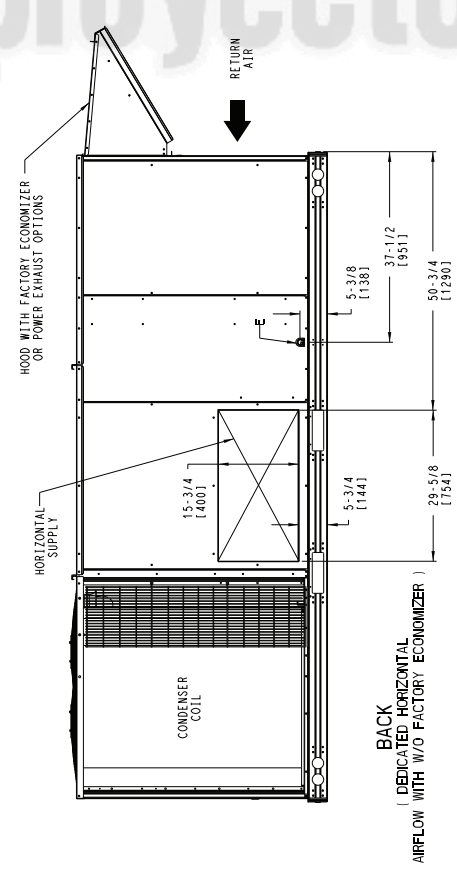
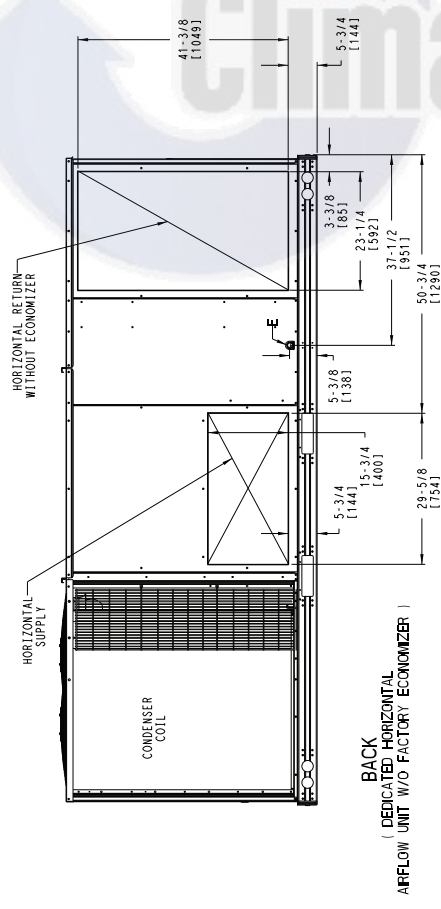

TIC CLASSIFICATION	SHEET	DATE	SUPERCEDES	50LC 14 SINGLE ZONE ELECTRICAL COOLING WITH ELECTRIC HEAT	REV
U.S. - ECCN: - NSR	3 OF 5	01/28/19	11/06/12		A

Fig. 4 — 50LC Back View and Condensate Drain Location (Size 14)

SUBMISSION OF THESE DRAWINGS OR DOCUMENTS DOES NOT CONSTITUTE PART PERFORMANCE OR ACCEPTANCE OF CONTRACT.

UNIT	STD UNIT WEIGHT *		CORNER WEIGHT (A)		CORNER WEIGHT (B)		CORNER WEIGHT (C)		CORNER WEIGHT (D)		C.G.		
	LBS.	KG.	LBS.	KG.	LBS.	KG.	LBS.	KG.	LBS.	KG.	X	Y	
50LC14	1754	797	425	193	495	225	447	203	384	175	40-29/32 [1039]	68-21/32 [1743]	16-1/2 [419]

* STANDARD UNIT WEIGHT IS WITHOUT ELECTRIC HEAT AND WITHOUT PACKAGING. FOR OTHER OPTIONS AND ACCESSORIES REFER TO THE PRODUCT DATA CATALOG.

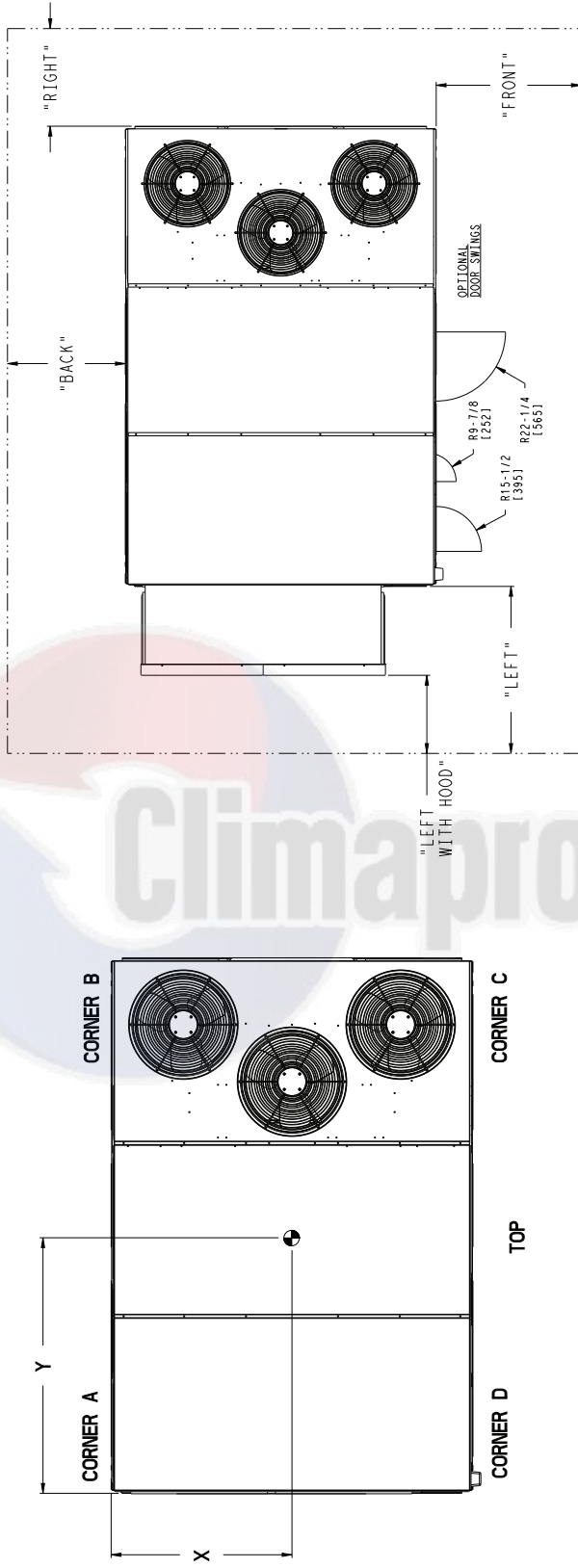

- NOTES:
1. CLEARANCE ABOVE THE UNIT TO BE 72"
 2. FOR ALL MINIMUM CLEARANCES LOCAL CODES OR JURISDICTIONS MAY PREVAIL.

SURFACE	CLEARANCE		OPERATING CLEARANCE
	SERVICE WITH CONDUCTIVE BARRIER	SERVICE WITH NONCONDUCTIVE BARRIER	
FRONT	48 [1219mm]	36 [914mm]	18 [457mm]
BACK	42 [1067mm]	42 [1067mm]	18 [457mm]
LEFT WITH HOOD	36 [914mm]	36 [914mm]	18 [457mm]
RIGHT	36 [914mm]	36 [914mm]	18 [457mm]
TOP	72 [1829mm]	72 [1829mm]	72 [1829mm]

TIC CLASSIFICATION	SHEET	DATE	SUPERCEDES	REV
U.S. ECCN: -NSR	4 OF 5	01/28/19	50LC14 SINGLE ZONE ELECTRICAL COOLING WITH ELECTRIC HEAT	A

Fig. 5 — 50LC Corner Weights and Clearances (Size 14)

SUBMISSION OF THESE DRAWINGS OR DOCUMENTS DOES NOT CONSTITUTE PART PERFORMANCE OR ACCEPTANCE OF CONTRACT.

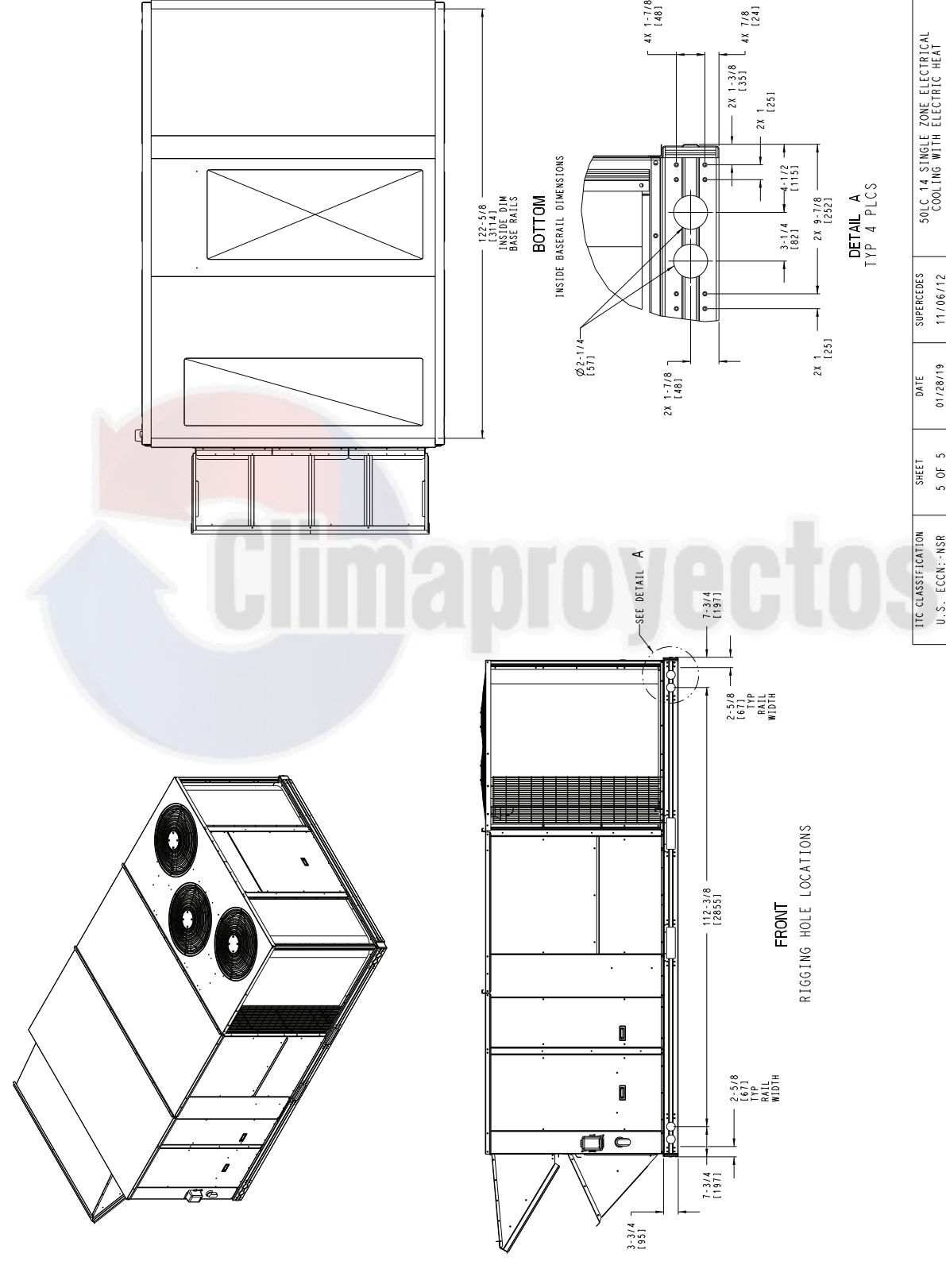

TIC CLASSIFICATION U.S. - ECCN: - NSR	SHEET 5 OF 5	DATE 01/28/19	SUPERCEDES 11/06/12	50LC 14 SINGLE ZONE ELECTRICAL COOLING WITH ELECTRIC HEAT	50LC50064	REV A
--	-----------------	------------------	------------------------	--	-----------	----------

Fig. 6 — 50LC Bottom View (Size 14)

SUBMISSION OF THESE DRAWINGS OR DOCUMENTS DOES NOT CONSTITUTE PART PERFORMANCE OR ACCEPTANCE OF CONTRACT.

CONNECTION SIZES	
A	1 3/8" DIA [135] FIELD POWER SUPPLY KNOCKOUT
B	3" DIA [176] FIELD POWER SUPPLY KNOCKOUT
C	3 5/8" DIA [192] FIELD POWER SUPPLY KNOCKOUT
D	7/8" DIA [22] FIELD CONTROL WIRING HOLE
G	7/8" DIA [22] FIELD CONTROL WIRING KNOCKOUT

- NOTES:
1. DIMENSIONS ARE IN INCHES. DIMENSIONS IN [] ARE IN MILLIMETERS.
 2. CENTER OF GRAVITY
 3. DIRECTION OF AIR FLOW
 4. ALL VIEW DRAWN USING 3RD ANGLE

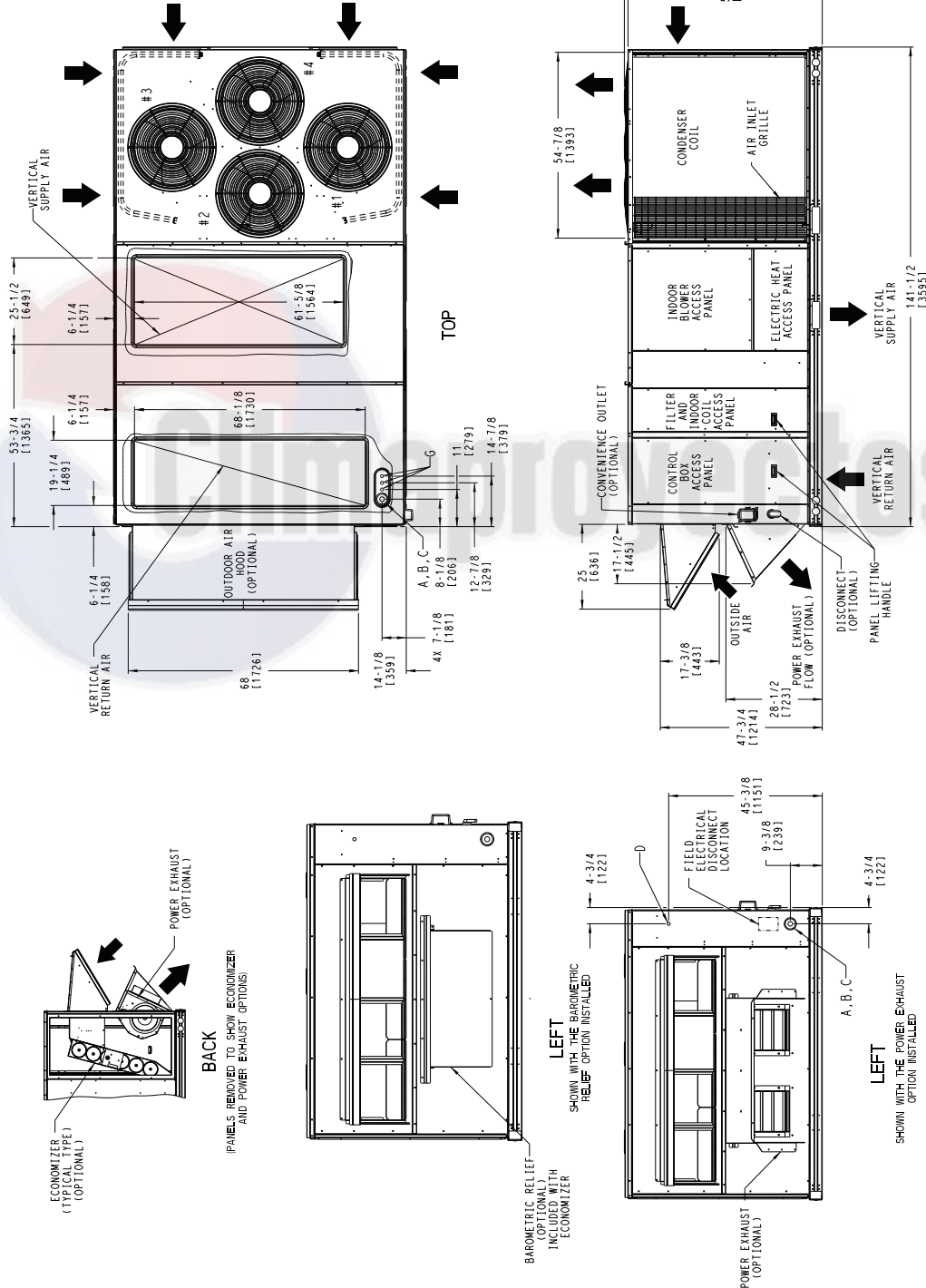

DEDICATED VERTICAL AIRFLOW UNIT

TIC CLASSIFICATION	SHEET	DATE	SUPERCEDES	REV
U.S. ECCN: NSR	1 OF 5	01/28/19	11/07/12	A
50LC 17,20 SINGLE ZONE ELECTRICAL COOLING WITH ELECTRIC HEAT				50LC500666

Fig. 7 — 50LC Vertical Airflow (Sizes 17-20)

SUBMISSION OF THESE DRAWINGS OR DOCUMENTS DOES NOT CONSTITUTE AN ACCEPTANCE OF PERFORMANCE OR ACCEPTANCE OF CONTRACT.

CONNECTION SIZES	
A.	1 3/8" DIA [35] FIELD POWER SUPPLY KNOCKOUT
B.	3" DIA [76] FIELD POWER SUPPLY KNOCKOUT
C.	3 5/8" DIA [92] FIELD POWER SUPPLY KNOCKOUT
D.	7/8" DIA [22] FIELD CONTROL WIRING HOLE
G.	7/8" DIA [22] FIELD CONTROL WIRING KNOCKOUT

- NOTES:
1. DIMENSIONS ARE IN INCHES. DIMENSIONS IN [] ARE IN MILLIMETERS.
 2. CENTER OF GRAVITY
 3. DIRECTION OF AIR FLOW
 4. ALL VIEW DRAWN USING 3RD ANGLE

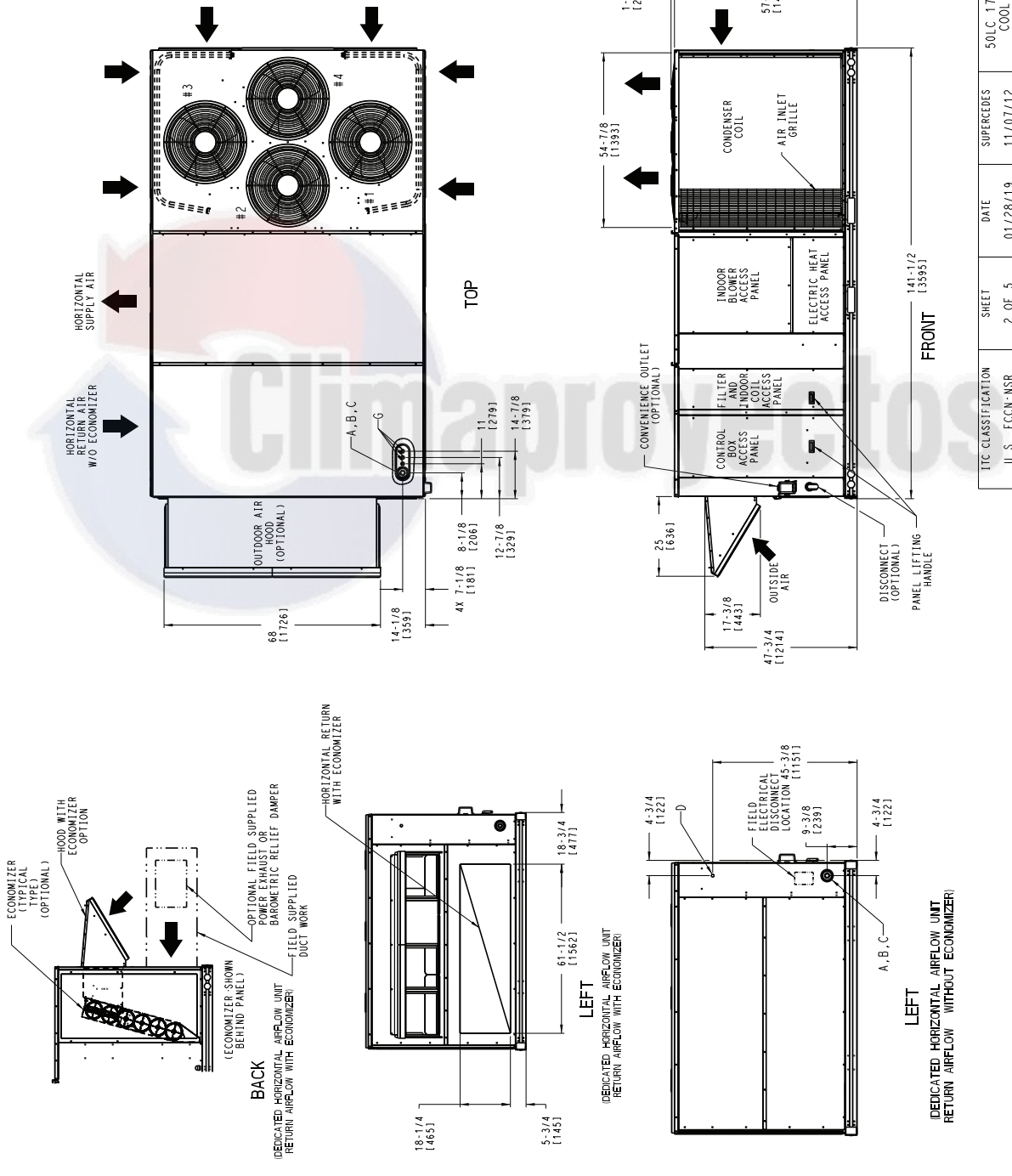

DEDICATED HORIZONTAL AIRFLOW UNIT

50LC 17-20 SINGLE ZONE ELECTRICAL COOLING WITH ELECTRIC HEAT

REV	50LC500666	SUPERCEDES	DATE	SHEET	TIC CLASSIFICATION
A			01/28/19	2 OF 5	U.S. - ECCN-NSR
			11/07/12		

Fig. 8 — 50LC Horizontal Airflow (Sizes 17-20)

SUBMISSION OF THESE DRAWINGS OR DOCUMENTS DOES NOT CONSTITUTE PART PERFORMANCE OR ACCEPTANCE OF CONTRACT.

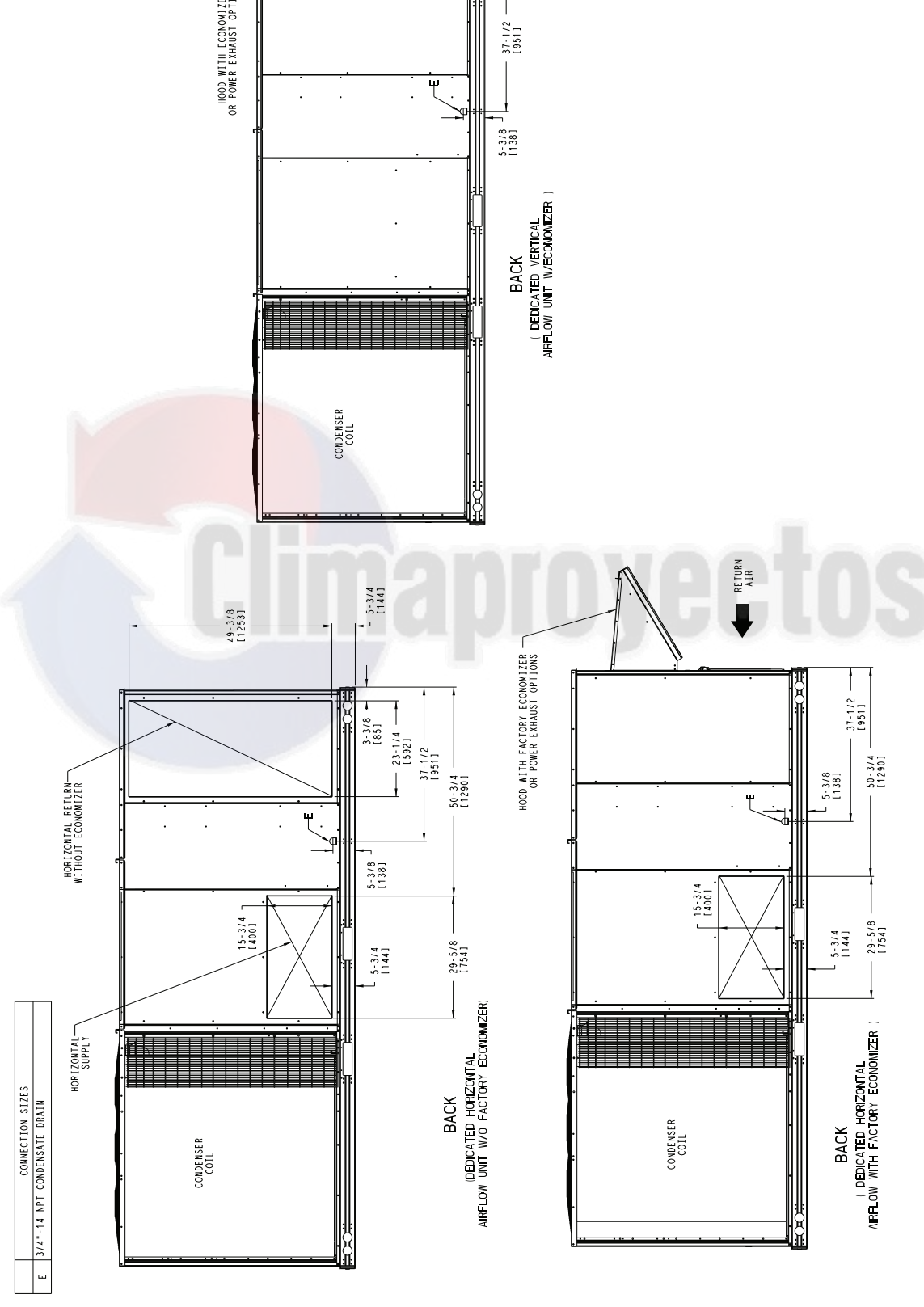

CONNECTION SIZES	
E	3/4"-14 MPT CONDENSATE DRAIN

TIC CLASSIFICATION U.S. ECCN: NSR	SHEET 3 OF 5	DATE 01/28/19	SUPERCEDES 11/07/12	50LC 17,20 SINGLE ZONE ELECTRICAL COOLING WITH ELECTRIC HEAT	50LC500666	REV A
--------------------------------------	-----------------	------------------	------------------------	--	------------	----------

Fig. 9 — 50LC Back View and Condensate Drain Location (Sizes 17-20)

SUBMISSION OF THESE DRAWINGS OR DOCUMENTS DOES NOT CONSTITUTE PART PERFORMANCE OR ACCEPTANCE OF CONTRACT.

UNIT	CORNER A		CORNER B		CORNER C		CORNER D		C.G.				
	WEIGHT * LBS.	WEIGHT * KG.	WEIGHT (B) LBS.	WEIGHT (C) KG.	WEIGHT (D) LBS.	WEIGHT (E) KG.	WEIGHT (F) LBS.	WEIGHT (G) KG.	X	Z			
50LC17	1996	907.3	510.2	231.9	487.5	221.6	479.8	218.1	412.2	187.3	38 1/2 [977.90]	76 [1930.40]	19 [482.6]
50LC20	2102	955.7	537.4	244.3	625.6	284.4	505.4	229.7	434.1	191.3	38 1/2 [977.90]	76 [1930.40]	19 [482.6]

* STANDARD UNIT WEIGHT IS WITHOUT ELECTRIC HEAT AND WITHOUT PACKAGING. FOR OTHER OPTIONS AND ACCESSORIES REFER TO THE PRODUCT DATA CATALOG.

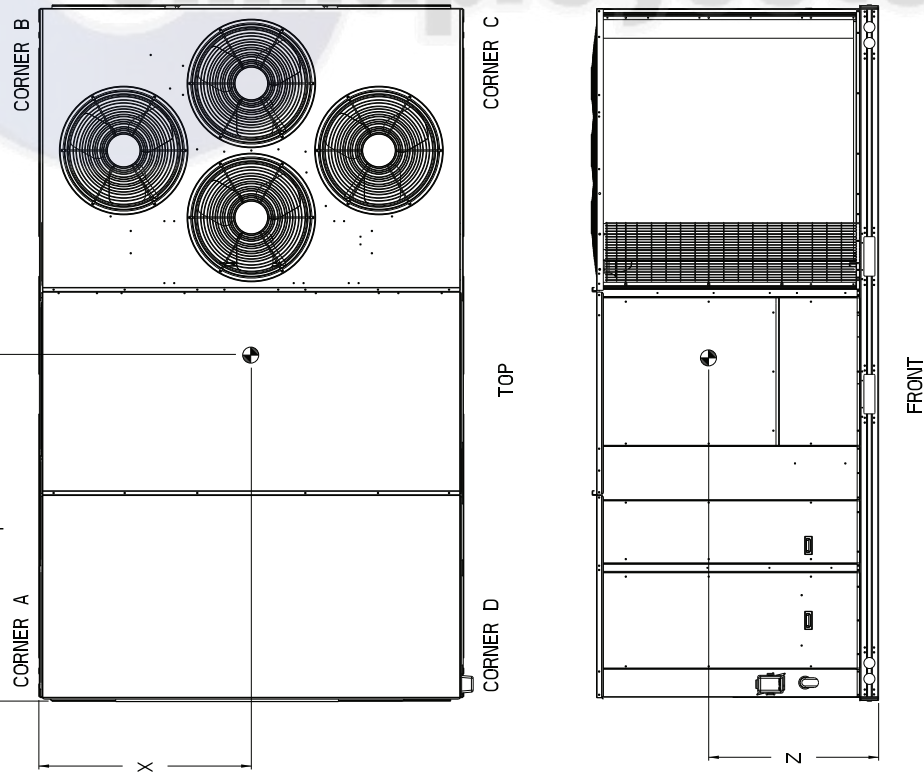

NOTES:

- CLEARANCE ABOVE THE UNIT TO BE 72"
- FOR ALL MINIMUM CLEARANCES LOCAL CODES OR JURISDICTIONS MAY PREVAIL.

SURFACE	CLEARANCE		OPERATING CLEARANCE
	SERVICE WITH CONDUCTIVE BARRIER	SERVICE WITH NONCONDUCTIVE BARRIER	
FRONT	48 [1219mm]	36 [914mm]	18 [457mm]
BACK	42 [1067mm]	42 [1067mm]	18 [457mm]
LEFT WITH HOOD	36 [914mm]	36 [914mm]	18 [457mm]
RIGHT	36 [914mm]	36 [914mm]	18 [457mm]
TOP	72 [1829mm]	72 [1829mm]	72 [1829mm]

TIC CLASSIFICATION U.S. ECCN: NSR	SHEET 4 OF 5	DATE 01/28/19	SUPERCEDES 11/07/12	50LC 17, 20 SINGLE ZONE ELECTRICAL COOLING WITH ELECTRIC HEAT	REV A
--------------------------------------	-----------------	------------------	------------------------	---	----------

Fig. 10 — 50LC Corner Weights and Clearances (Sizes 17-20)

SUBMISSION OF THESE DRAWINGS OR DOCUMENTS DOES NOT CONSTITUTE PART PERFORMANCE OR ACCEPTANCE OF CONTRACT.

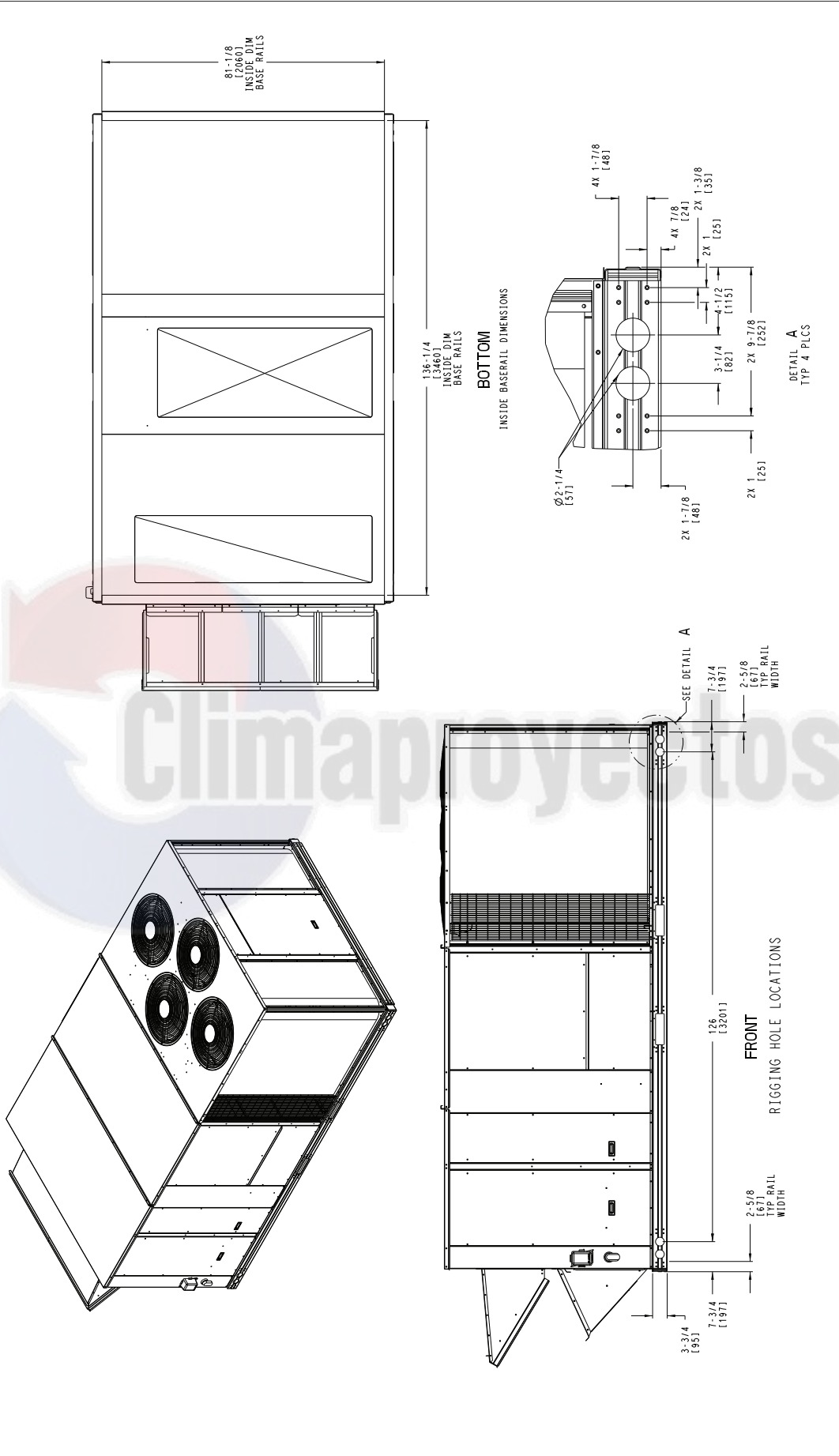

TIC CLASSIFICATION U.S. ECCN: NSR	SHEET 5 OF 5	DATE 01/28/19	SUPERCEDES 11/07/12	50LC 17, 20 SINGLE ZONE ELECTRICAL COOLING WITH ELECTRIC HEAT	50LC500666	REV A
--------------------------------------	-----------------	------------------	------------------------	---	------------	----------

Fig. 11 — 50LC Bottom View (Sizes 17-20)

SUBMISSION OF THESE DRAWINGS OR DOCUMENTS DOES NOT CONSTITUTE PART PERFORMANCE OR ACCEPTANCE OF CONTRACT.

CONNECTION SIZES	
A	1 3/8" DIA [351] FIELD POWER SUPPLY KNOCKOUT
B	3" DIA [76] FIELD POWER SUPPLY KNOCKOUT
C	3 5/8" DIA [92] FIELD POWER SUPPLY KNOCKOUT
D	7/8" DIA [22] FIELD CONTROL WIRING HOLE
G	7/8" DIA [22] FIELD CONTROL WIRING KNOCKOUT

- NOTES:
1. DIMENSIONS ARE IN INCHES. DIMENSIONS IN [] ARE IN MILLIMETERS.
 2. CENTER OF GRAVITY
 3. DIRECTION OF AIR FLOW
 4. ALL VIEW DRAWN USING 3RD ANGLE

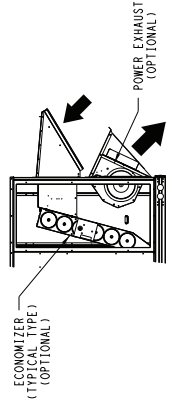
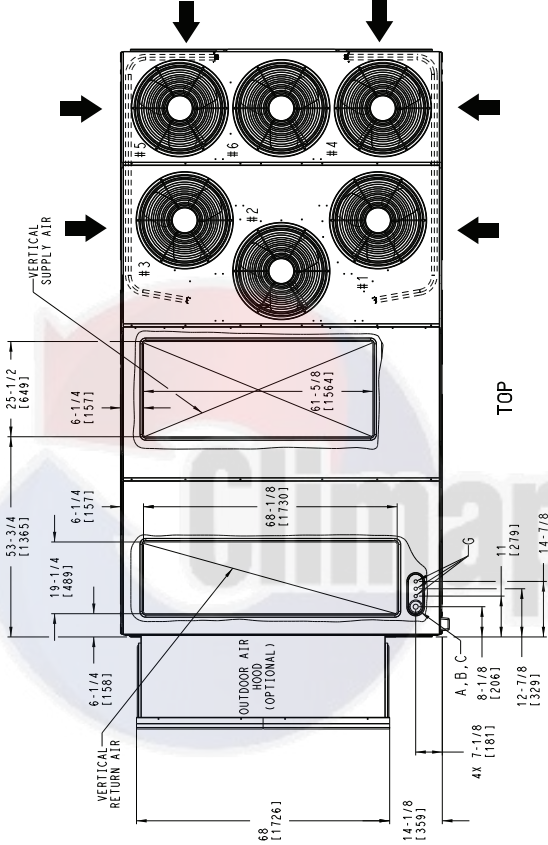

BACK
 PANELS REMOVED TO SHOW ECONOMIZER AND POWER EXHAUST OPTIONS

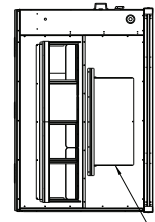

LEFT
 SHOWN WITH THE BAROMETRIC RELIEF OPTION INSTALLED

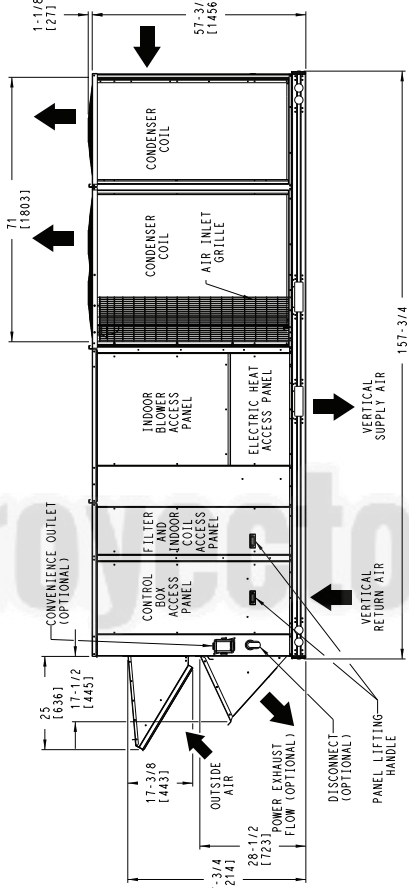

FRONT

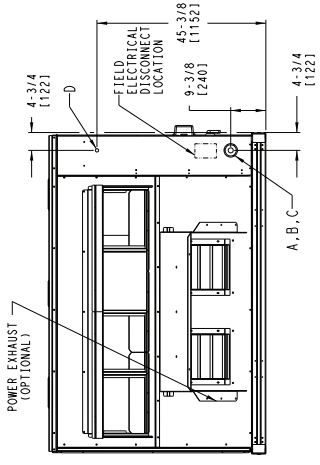

LEFT
 SHOWN WITH THE POWER EXHAUST OPTION INSTALLED

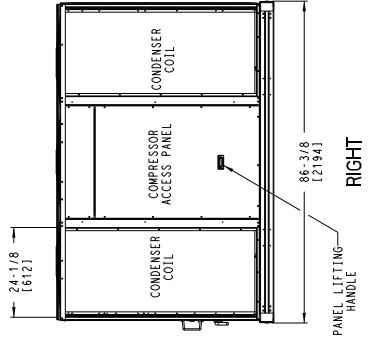

RIGHT

DEDICATED VERTICAL AIRFLOW UNIT

REV	DATE	SUPERCEDES	SHEET	U.S. ECCN: NSR	U.S. ECCN: NSR	DATE	SUPERCEDES	SHEET	U.S. ECCN: NSR	U.S. ECCN: NSR	DATE	SUPERCEDES	SHEET	U.S. ECCN: NSR	U.S. ECCN: NSR
A	01/29/19	11/08/12	1 OF 5	U.S. ECCN: NSR	U.S. ECCN: NSR	01/29/19	11/08/12	1 OF 5	U.S. ECCN: NSR	U.S. ECCN: NSR	01/29/19	11/08/12	1 OF 5	U.S. ECCN: NSR	U.S. ECCN: NSR

50LC 24, 26 SINGLE ZONE ELECTRICAL COOLING WITH ELECTRIC HEAT

50LC 24, 26 SINGLE ZONE ELECTRICAL COOLING WITH ELECTRIC HEAT

50LC 24, 26 SINGLE ZONE ELECTRICAL COOLING WITH ELECTRIC HEAT

50LC 24, 26 SINGLE ZONE ELECTRICAL COOLING WITH ELECTRIC HEAT

50LC 24, 26 SINGLE ZONE ELECTRICAL COOLING WITH ELECTRIC HEAT

50LC 24, 26 SINGLE ZONE ELECTRICAL COOLING WITH ELECTRIC HEAT

Fig. 12 — 50LC Vertical Airflow (Sizes 24-26)

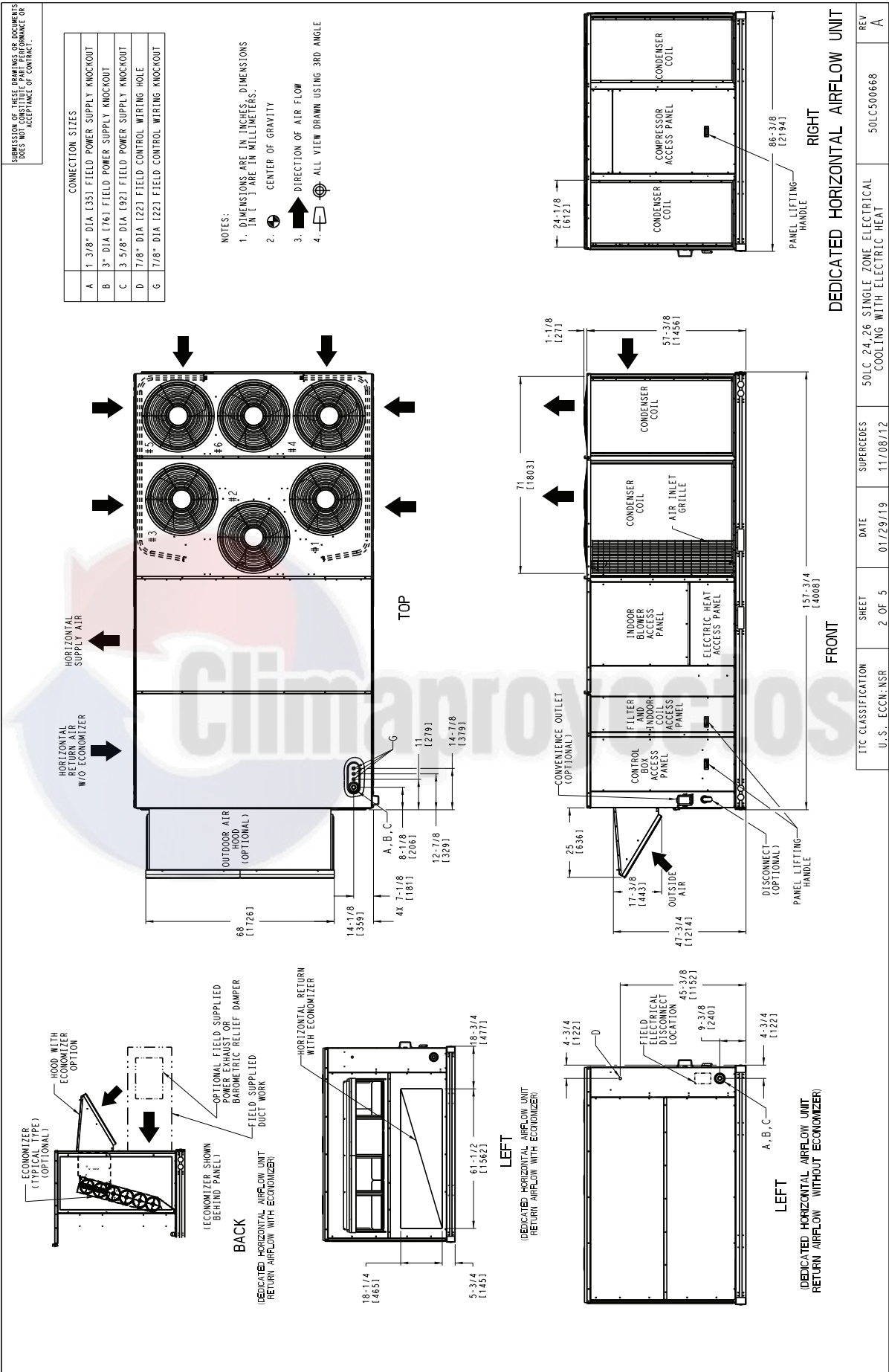
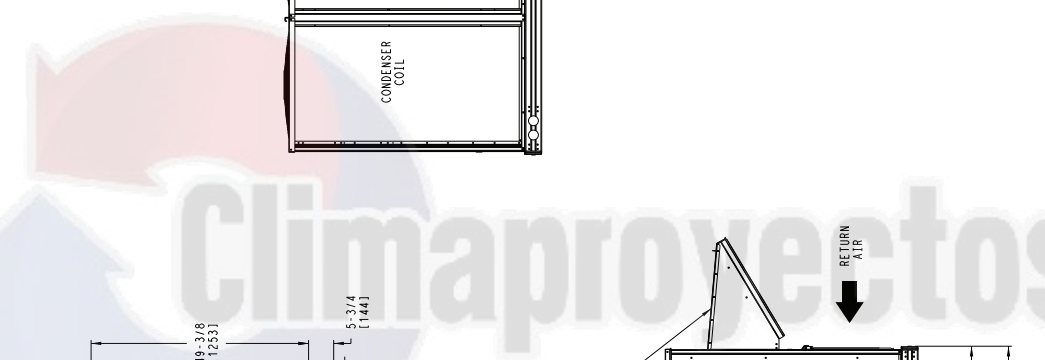
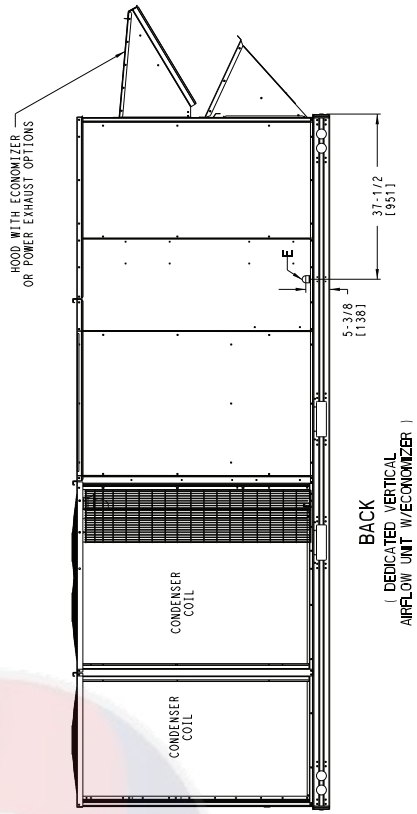
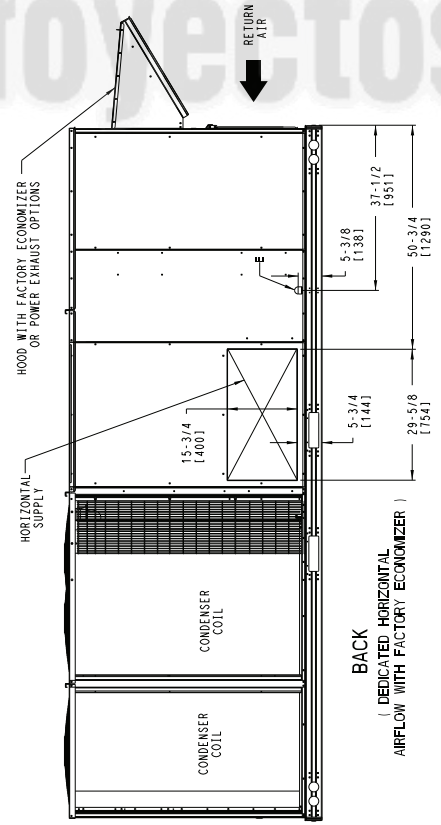
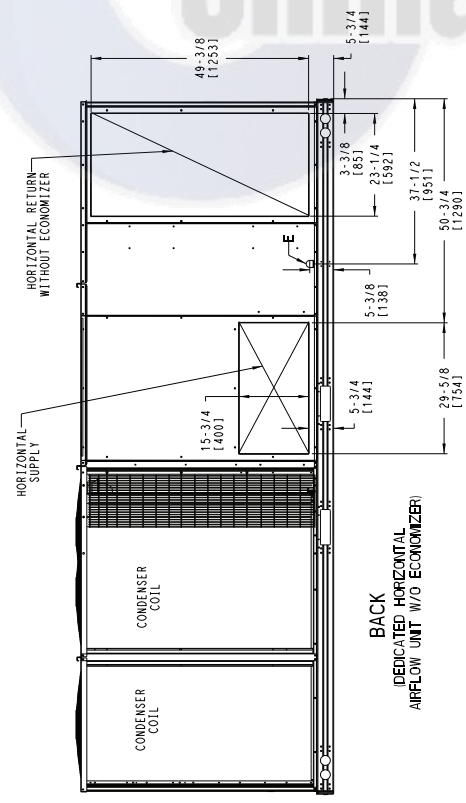

Fig. 13 — 50LC Horizontal Airflow (Sizes 24-26)

SUBMISSION OF THESE DRAWINGS OR DOCUMENTS DOES NOT CONSTITUTE PART PERFORMANCE OR ACCEPTANCE OF CONTRACT.

CONNECTION SIZES	
E	3/4"-14 NPT CONDENSATE DRAIN



TIC CLASSIFICATION	SHEET	DATE	SUPERCEDES	50LC 24, 26 SINGLE ZONE ELECTRICAL COOLING WITH ELECTRIC HEAT	REV
U.S. ECCN: NSR	3 OF 5	01/29/19	11/08/12		A

Fig. 14 — 50LC Back View and Condensate Drain Location (Sizes 24-26)

SUBMISSION OF THESE DRAWINGS OR DOCUMENTS DOES NOT CONSTITUTE PART PERFORMANCE OR ACCEPTANCE OF CONTRACT.

UNIT	STD UNIT WEIGHT *		CORNER WEIGHT (A)		CORNER WEIGHT (B)		CORNER WEIGHT (C)		CORNER WEIGHT (D)		C.G.	
	LBS.	KG.	LBS.	KG.	LBS.	KG.	LBS.	KG.	LBS.	KG.	X	Y
50LC24	2248	1022.0	458.3	208.3	537.5	244.3	676.2	307.4	576.5	262.1	48	1219.201
50LC26	2393	1087.6	534.0	242.7	595.1	270.5	666.0	302.7	597.6	271.6	45	1155.701
											83	1132.2108.991
											85	1132.2159.791
											19	1482.6
											19	1482.6

* STANDARD UNIT WEIGHT IS WITHOUT ELECTRIC HEAT AND WITHOUT PACKAGING.
 FOR OTHER OPTIONS AND ACCESSORIES REFER TO THE PRODUCT DATA CATALOG.

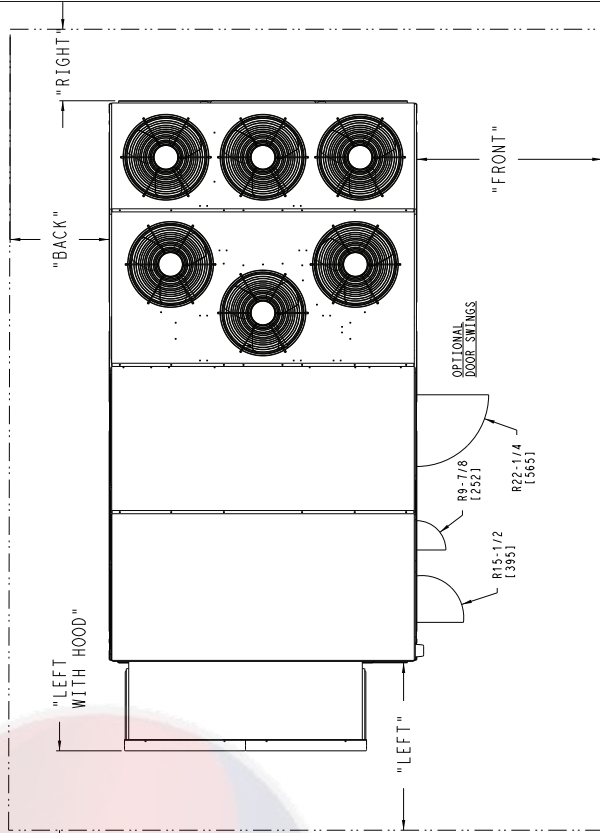

- NOTES:
- CLEARANCE ABOVE THE UNIT TO BE 72"
 - FOR ALL MINIMUM CLEARANCES LOCAL CODES OR JURISDICTIONS MAY PREVAIL.

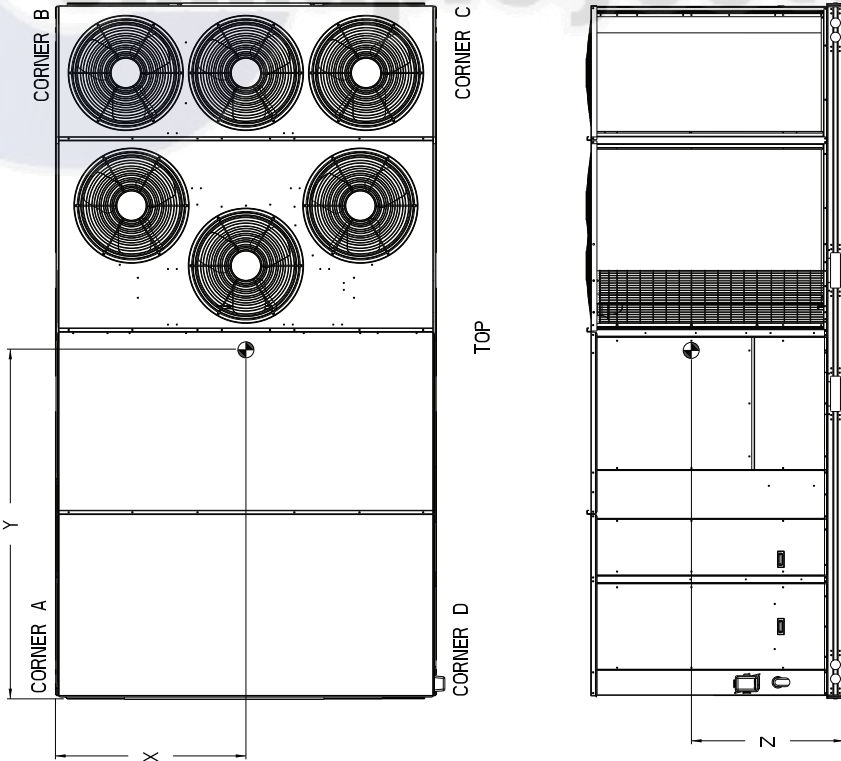

SURFACE	CLEARANCE			OPERATING CLEARANCE
	SERVICE WITH CONDUCTIVE BARRIER	SERVICE WITH NONCONDUCTIVE BARRIER	SERVICE WITH CONDUCTIVE BARRIER	
FRONT	48 [1219mm]	42 [1067mm]	36 [914mm]	18 [457mm]
BACK	42 [1067mm]	36 [914mm]	36 [914mm]	18 [457mm]
LEFT WITH HOOD	36 [914mm]	36 [914mm]	36 [914mm]	18 [457mm]
RIGHT	36 [914mm]	36 [914mm]	36 [914mm]	18 [457mm]
TOP	72 [1829mm]	72 [1829mm]	72 [1829mm]	72 [1829mm]

SUPERCEDES	50LC 24, 26 SINGLE ZONE ELECTRICAL COOLING WITH ELECTRIC HEAT
DATE	01/29/19
SHEET	4 OF 5
TIC CLASSIFICATION	U.S. ECCN-NSR
REV	A

Fig. 15 — 50LC Corner Weights and Clearances (Sizes 24-26)

SUBMISSION OF THESE DRAWINGS OR DOCUMENTS DOES NOT CONSTITUTE PART PERFORMANCE OR ACCEPTANCE OF CONTRACT.

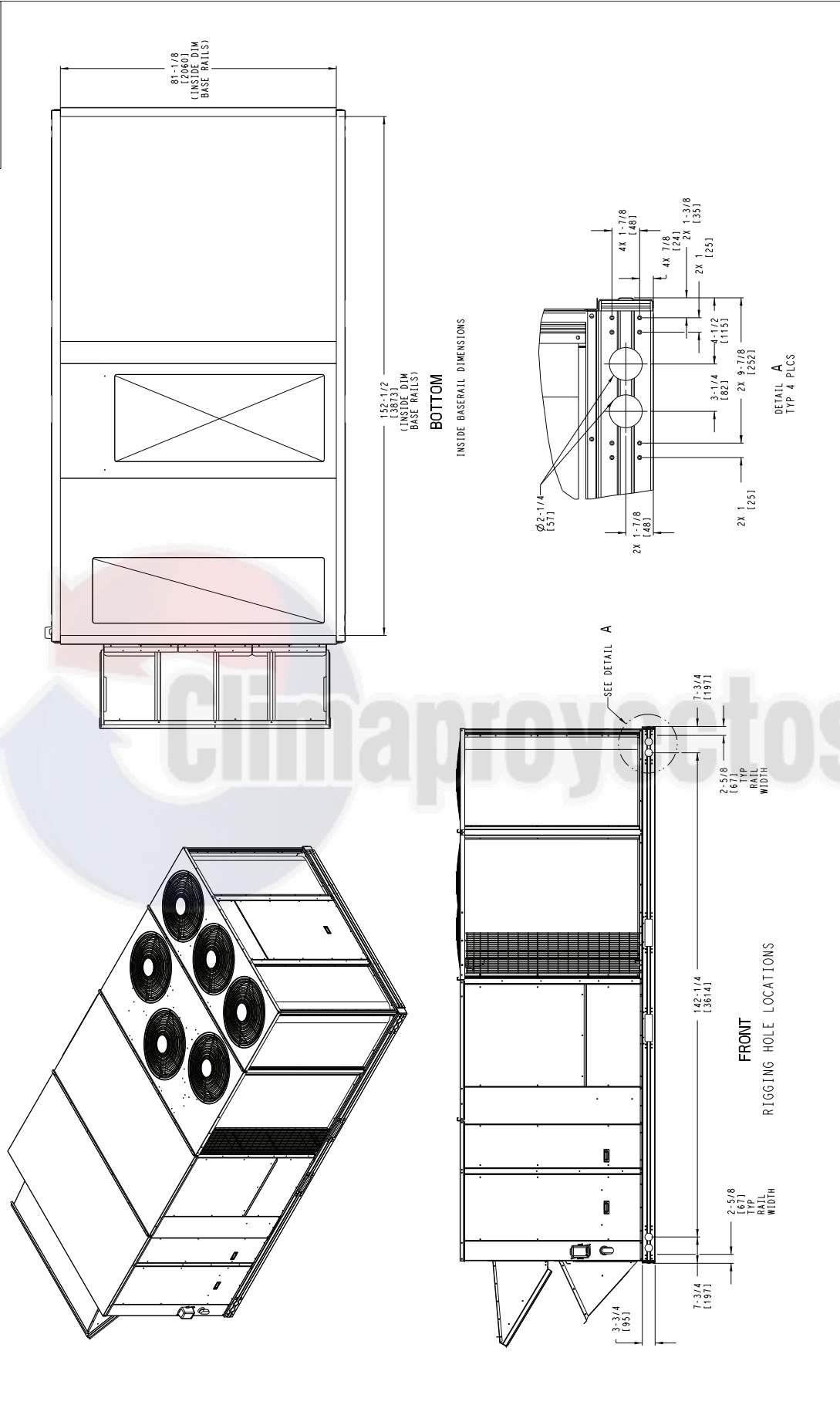

TIC CLASSIFICATION U.S. ECCN: NSR	SHEET 5 OF 5	DATE 01/29/19	SUPERCEDES 11/08/12	50LC 24, 26 SINGLE ZONE ELECTRICAL COOLING WITH ELECTRIC HEAT	50LC50068	REV A
--------------------------------------	-----------------	------------------	------------------------	--	-----------	----------

Fig. 16 — 50LC Bottom View (Sizes 24-26)

Table 2 — Operating Weights

50LC-*	UNIT LB (KG)				
	14	17	20	24	26
Base Unit	1754 (797.3)	1996 (907.3)	2102 (955.7)	2248 (1022.0)	2393 (1087.6)
Economizer	246 (112)	246 (112)	246 (112)	246 (112)	246 (112)
Powered Outlet	35 (16)	35 (16)	35 (16)	35 (16)	35 (16)
Curb					
14-in. (356 mm)	240 (109)	240 (109)	255 (116)	255 (116)	273 (124)
24-in. (610 mm)	340 (154)	340 (154)	355 (161)	355 (161)	355 (161)

INSTALLATION

Jobsite Survey

Complete the following checks before installation.

1. Consult local building codes and the NEC (National Electrical Code) ANSI/NFPA 70 for special installation requirements.
2. Determine unit location (from project plans) or select unit location.
3. Check for possible overhead obstructions which may interfere with unit lifting or rigging.

Step 1 — Plan for Unit Location

Select a location for the unit and its support system (curb or other) that provides for the minimum clearances required for safety. This includes the clearance to combustible surfaces), unit performance and service access below, around and above unit as specified in unit drawings. See Fig. 5, 10, and 15.

NOTE: Consider also the effect of adjacent units.

Unit may be installed directly on wood flooring or on Class A, B, or C roof-covering material when roof curb is used.

Do not install unit in an indoor location. Do not locate air inlets near exhaust vents or other sources of contaminated air.

Although unit is weatherproof, avoid locations that permit water from higher level runoff and overhangs to fall onto unit.

Select a unit mounting system that provides adequate height to allow installation of condensate trap per requirements. Refer to Step 11 — Install External Condensate Trap and Line on page 28 for required trap dimensions.

ROOF MOUNT

Check building codes for weight distribution requirements. Unit operating weight is shown in Table 2.

Step 2 — Plan for Sequence of Unit Installation

The support method used for this unit will dictate different sequences for the steps of unit installation. For example, on curb-mounted units, some accessories must be installed on the unit before the unit is placed on the curb. Review the following for recommended sequences for installation steps:

CURB-MOUNTED INSTALLATION

1. Install curb
2. Install field-fabricated ductwork inside curb
3. Install accessory thru-base service connection package (affects curb and unit)
4. Rig and place unit
5. Remove top skid
6. Install outdoor air hood
7. Install smoke detector tube
8. Install condensate line trap and piping
9. Make electrical connections
10. Install other accessories

PAD-MOUNTED INSTALLATION

1. Prepare pad and unit supports
2. Rig and place unit
3. Remove duct covers and top skid

4. Install return air smoke detector tube
5. Install field-fabricated ductwork at unit duct openings
6. Install outdoor air hood
7. Install condensate line trap and piping
8. Make electrical connections
9. Install other accessories

FRAME-MOUNTED INSTALLATION

Frame-mounted applications generally follow the sequence for a curb installation. Adapt the sequence as required to suit specific installation plan.

Step 3 — Inspect Unit

Inspect unit for transportation damage. File any claim with transportation agency.

Confirm before installation of unit that voltage, amperage and circuit protection requirements listed on unit data plate agree with power supply provided.

On units with hinged panel option, check to be sure all latches are snug and in closed position.

Locate the carton containing the outside air hood parts. See Fig. 17. Do not remove carton until unit has been rigged and located in final position.

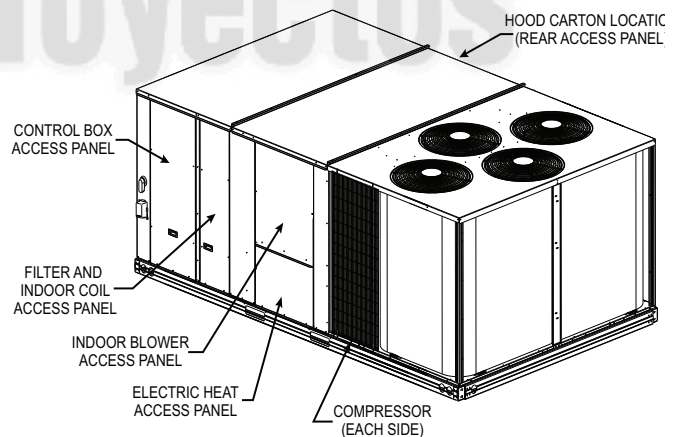

Fig. 17 — Typical Access Panel and Compressor Locations

Step 4 — Provide Unit Support

ROOF CURB MOUNT

Accessory roof curb details and dimensions are shown in Fig. 19-21. Assemble and install accessory roof curb in accordance with instructions shipped with the curb.

The gasketing of the unit to the roof curb is critical for a water-tight seal. Install gasket supplied with the roof curb as shown in Fig. 19-21. Improperly applied gasket can also result in air leaks and poor unit performance.

Curb should be level. This is necessary for unit drain to function properly. Unit leveling tolerances are shown in Fig. 18. Refer to Accessory Roof Curb Installation Instructions for additional information as required.

Install insulation, cant strips, roofing felt, and counter flashing as shown. *Ductwork must be attached to curb and not to the unit. The accessory thru-the-base power connection package must be installed before the unit is set on the roof curb.*

If electric and control wiring is to be routed through the basepan, remove knockouts in basepan located in control box area of access panel; see Fig. 2, 7, or 12 for basepan knockout locations. Attach the service connections to the basepans.

SLAB MOUNT (HORIZONTAL UNITS ONLY)

Provide a level concrete slab that extends a minimum of 6-in. (150 mm) beyond unit cabinet. Install a gravel apron in front of condenser coil air inlet to prevent grass and foliage from obstructing airflow.

NOTE: Horizontal units may be installed on a roof curb if required.

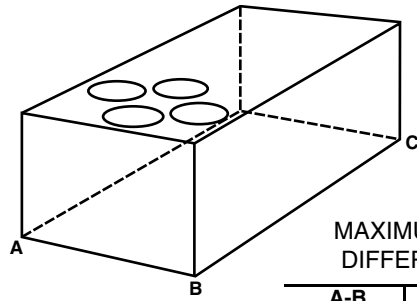

MAXIMUM ALLOWABLE DIFFERENCE IN. (MM)

A-B	B-C	A-C
0.25 (6)	0.5 (12)	0.5 (12)

Fig. 18 — Unit Leveling Tolerances

ALTERNATE UNIT SUPPORT (IN LIEU OF CURB OR SLAB MOUNT)

A non-combustible sleeper rail can be used in the unit curb support area. If sleeper rails cannot be used, support the long sides of the unit with a minimum of 4 equally spaced 4-in. x 4-in. (102 mm x 102 mm) pads on each side. Locate pads so that they support the rails. Make sure to avoid the fork openings.



UNIT SIZE	"A"	ROOF CURB ACCESSORY
14	1'-2" [356.0]	CRRFCURB045A00
	2'-0" [610.0]	CRRFCURB046A00

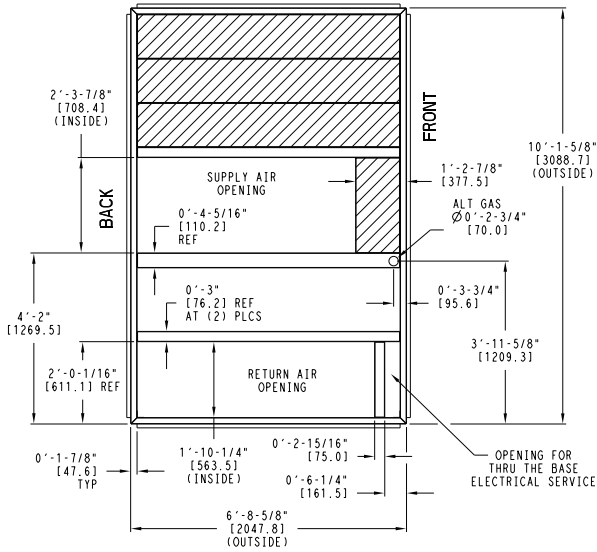

- NOTES:
- 1 ROOF CURB ACCESSORY IS SHIPPED UNASSEMBLED.
 - 2 DIMENSIONS IN () ARE IN MILLIMETERS.
 - 3 ROOF CURB GALVANIZED STEEL.
 - 4 ATTACH DUCTWORK TO CURB (FLANGES ON DUCT REST ON CURB)
 - 5 SERVICE CLEARANCE 4 FT ON EACH SIDE
- ➔ DIRECTION OF AIR FLOW

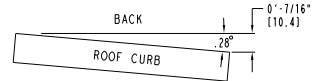

MAX CURB LEVELING TOLERANCES

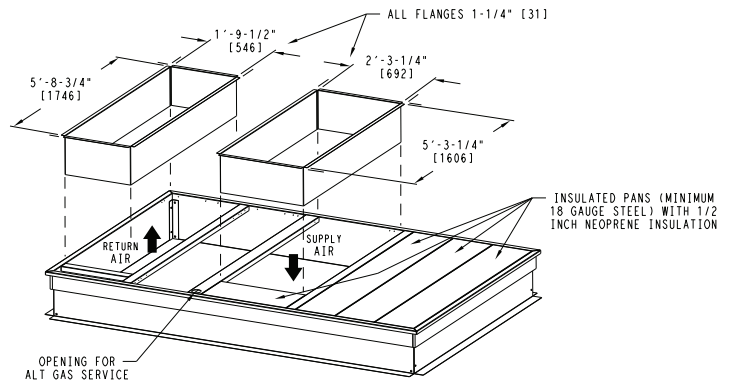
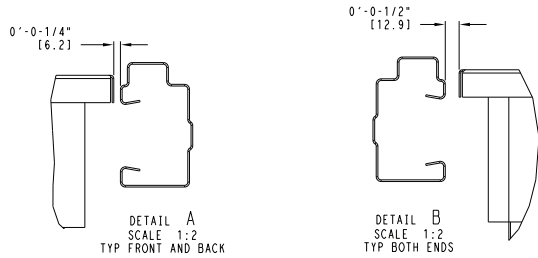
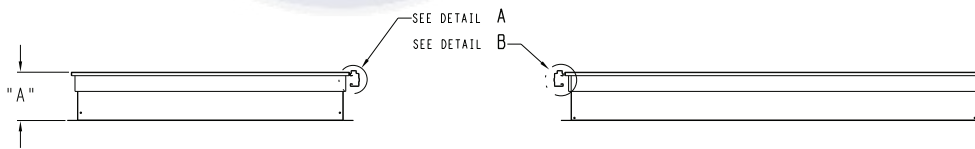
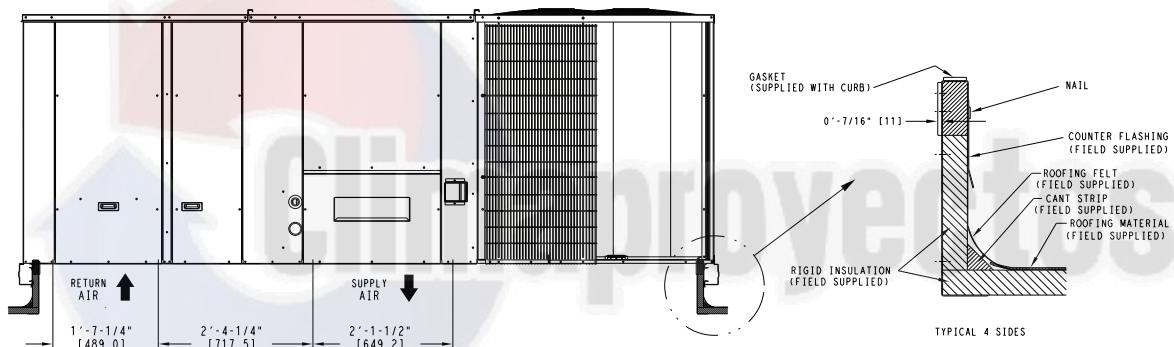
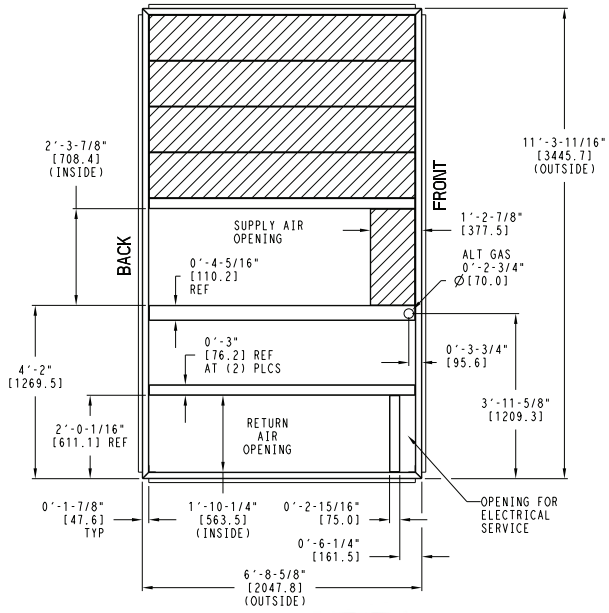
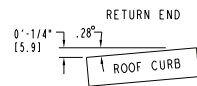
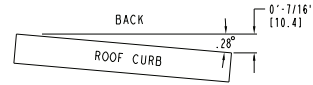

Fig. 19 — Roof Curb Details - 14 Size Unit

UNIT SIZE	"A"	ROOF CURB ACCESSORY
17, 20	1'-2" [356.0]	CRRFCURB047A00
	2'-0" [610.0]	CRRFCURB048A00



- NOTES:
- 1 ROOF CURB ACCESSORY IS SHIPPED UNASSEMBLED.
 - 2 DIMENSIONS IN () ARE IN MILLIMETERS.
 - 3 ROOF CURB GALVANIZED STEEL.
 - 4 ATTACH DUCTWORK TO CURB (FLANGES ON DUCT REST ON CURB)
 - 5 SERVICE CLEARANCE 4 FT ON EACH SIDE
- ➔ DIRECTION OF AIR FLOW



MAX CURB LEVELING TOLERANCES

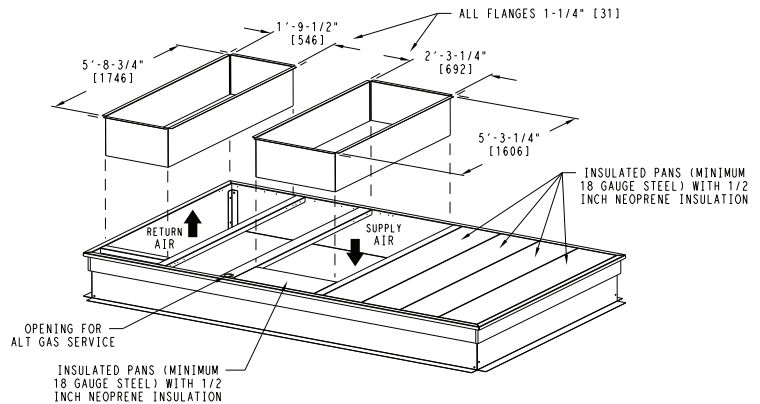
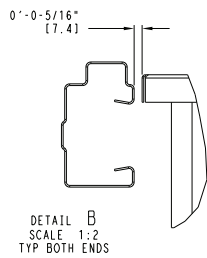
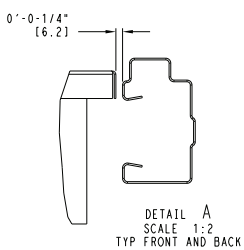
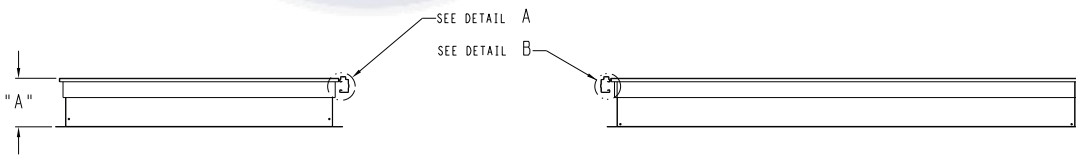
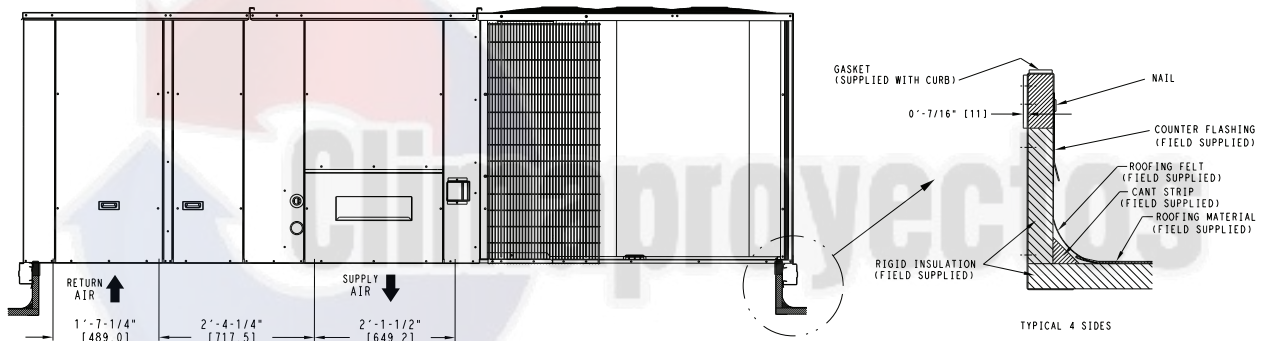
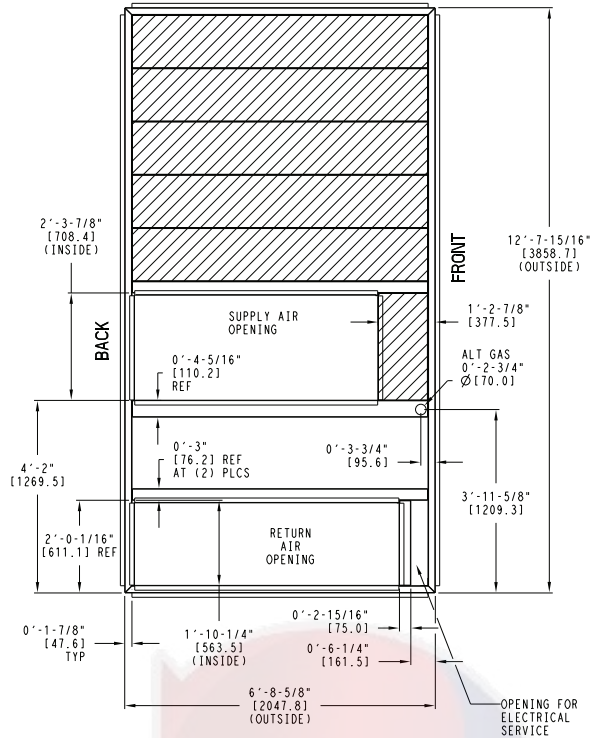

Fig. 20 — Roof Curb Details - 17 and 20 Size Units

UNIT SIZE	"A"	ROOF CURB ACCESSORY
24, 26	1'-2" [356.0] 2'-0" [610.0]	CRRFCURB049A00 CRRFCURB050A00



- NOTES:
- 1 ROOF CURB ACCESSORY IS SHIPPED UNASSEMBLED.
 - 2 BOLT HEADS TO BE ON INSIDE OF FLANGE. CLEARANCE IS [11] 0-0-7/16" TYP ALL CORNERS.
 - 3 DIMENSIONS IN [] ARE IN MILLIMETERS.
 - 4 ROOF CURB GALVANIZED STEEL.
 - 5 ATTACH DUCTWORK TO CURB (FLANGES ON DUCT REST ON CURB)
 - 6 SERVICE CLEARANCE 4 ft ON EACH SIDE
 - 7 GAS SERVICE PLATE IS PART OF A SEPARATELY SHIPPED ACCESSORY PACKAGE.
 - 8 GAS SERVICE PLATE CAN BE USED WITH EITHER ACCESSORY ROOF CURB.

➔ DIRECTION OF AIR FLOW

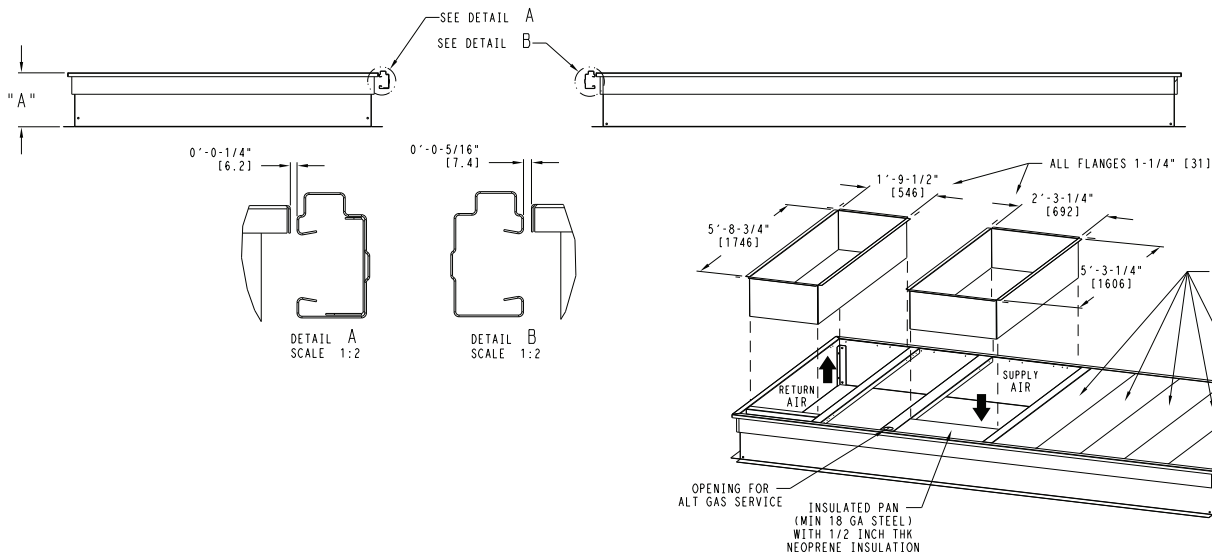
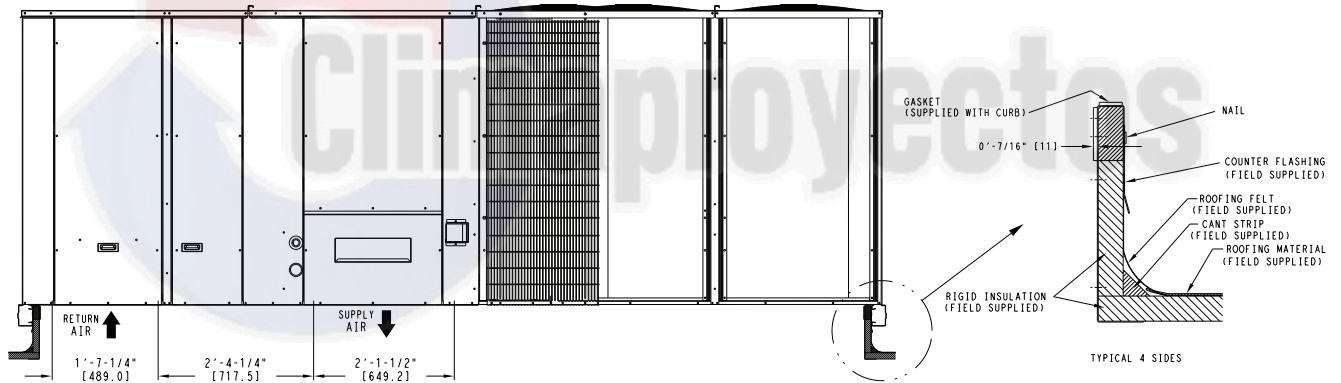
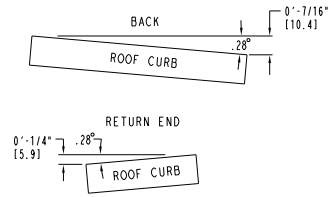

Fig. 21 — Roof Curb Details - 24 and 26 Size Units

Step 5 — Field Fabricate Ductwork

Cabinet return-air static pressure (a negative condition) shall not exceed 0.35 in. wg (87 Pa) with economizer or without economizer.

For vertical ducted applications, secure all ducts to roof curb and building structure. *Do not connect ductwork to unit.*

Fabricate supply ductwork so that the cross sectional dimensions are equal to or greater than the unit supply duct opening dimensions for the first 18-in. (458 mm) of duct length from the unit basepan.

Insulate and weatherproof all external ductwork, joints, and roof openings with counter flashing and mastic in accordance with applicable codes.

Ducts passing through unconditioned spaces must be insulated and covered with a vapor barrier.

If a plenum return is used on a vertical unit, the return should be ducted through the roof deck to comply with applicable fire codes.

⚠ WARNING

PERSONAL INJURY HAZARD

Failure to follow this warning could cause personal injury.

For vertical supply and return units, tools or parts could drop into ductwork and cause an injury. Install a 90 degree turn in the return ductwork between the unit and the conditioned space. If a 90 degree elbow cannot be installed, then a grille of sufficient strength and density should be installed to prevent objects from falling into the conditioned space. Due to electric heater, supply duct will require 90 degree elbow.

⚠ CAUTION

PROPERTY DAMAGE HAZARD

Failure to follow this caution may result in damage to roofing materials.

Membrane roofs can be cut by sharp sheet metal edges. Be careful when placing any sheet metal parts on such roof.

UNITS WITH ACCESSORY OR OPTIONAL ELECTRIC HEATERS

Minimum clearance is not required around ductwork.

Step 6 — Rig and Place Unit

⚠ CAUTION

UNIT DAMAGE HAZARD

Failure to follow this caution may result in equipment damage.

All panels must be in place when rigging. Unit is not designed for handling by fork truck when packaging is removed.

If using top crate as spreader bar, once unit is set, carefully lower wooden crate off building roof top to ground. Ensure that no people or obstructions are below prior to lowering the crate.

Keep unit upright and do not drop. Spreader bars are not required if top crating is left on unit. Rollers may be used to move unit across a roof. Level by using unit frame as a reference. See Table 2 on page 19 and Fig. 22 for additional information.

Lifting holes are provided in base rails as shown in Fig. 22. Refer to rigging instructions on unit.

Before setting the unit onto the curb, recheck gasketing on curb.

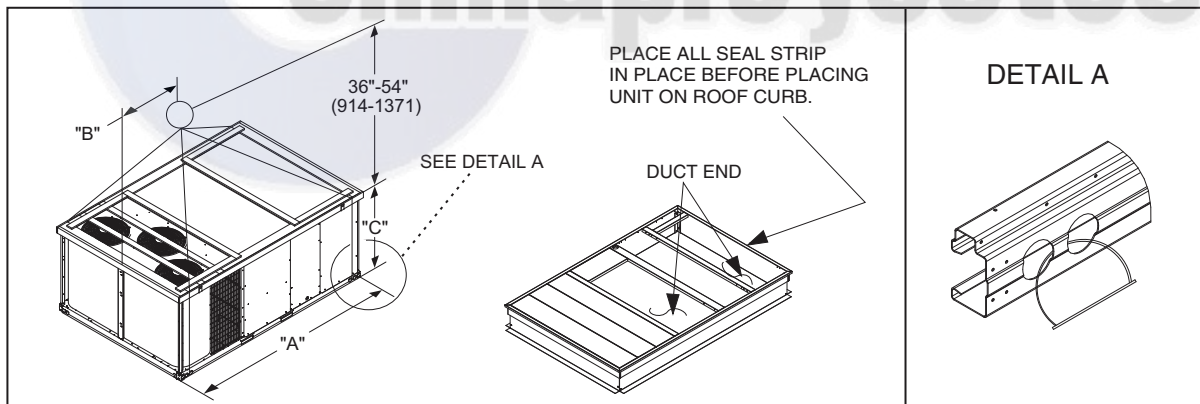

UNIT	MAX WEIGHT		DIMENSIONS					
			A		B		C	
	LB	KG	IN.	MM	IN.	MM	IN.	MM
50LC-*14	2004	911	127.8	3249	59.1	1501	52.3	1328
50LC-*17	2246	1021	141.5	3595	65.5	1664	60.3	1532
50LC-*20	2353	1069	141.5	3595	65.5	1664	60.3	1532
50LC-*24	2499	1136	157.8	4007	72.8	1849	60.3	1532
50LC-*26	2643	1201	157.8	4007	72.8	1849	60.3	1532

NOTES:

- Dimensions in () are in millimeters.
- Hook rigging shackles through holes in base rail, as shown in detail "A." Holes in base rails are centered around the unit center of gravity. Use wooden top to prevent rigging straps from damaging unit.

Fig. 22 — Rigging Details

POSITIONING ON CURB

Position unit on roof curb so that the following clearances are maintained: 1/4-in. (6 mm) clearance between the roof curb and the base rail inside the right and left, 1/2-in. (12 mm) clearance between the roof curb and the base rail inside the front and back. This will result in the distance between the roof curb and the base rail being approximately equal to detail A and detail B in Fig. 19-21.

Do not attempt to slide unit on curb after unit is set. Doing so will result in damage to the roof curb seal.

Although unit is weatherproof, guard against water from higher level runoff and overhangs.

After unit is in position, remove rigging skids and shipping materials.

Step 7 — Horizontal Duct Connection

Refer to Fig. 2-16 for locations and sizes of the horizontal duct connections. Note that there are two different return air duct connection locations – one for unit without an economizer (on back side of unit) and a different one for unit equipped with an economizer (on left end, under the economizer hood). The supply air duct connection is on the back side. See Fig. 23 for top view depicting typical horizontal duct arrangements.

Field-supplied (3/4-in.) flanges should be attached to horizontal duct openings (see Fig. 23) and all ductwork should be secured to the flanges. Insulate and weatherproof all external ductwork, joints, and roof or building openings with counter flashing and mastic in accordance with applicable codes.

NOTE: 50LC size 17 to 26 units are factory assembled as either dedicated horizontal or vertical units. These units cannot be field converted.

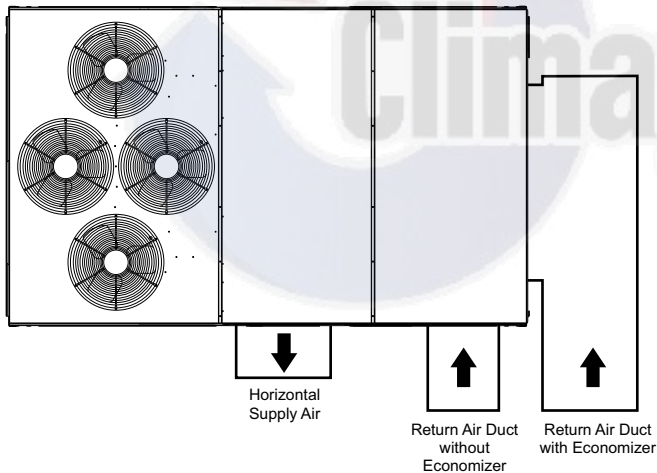

	SUPPLY	RETURN WITHOUT ECONOMIZER	RETURN WITH ECONOMIZER
Location	Back	Back	Left End
Height - in. (mm)	15 ⁷ / ₈ (402)	49 ³ / ₈ (1253)	18 ³ / ₈ (467)
Width - in. (mm)	29 ³ / ₄ (756)	23 ³ / ₈ (593)	61 ⁵ / ₈ (1564)

Fig. 23 — Horizontal Duct Opening Dimensions

Step 8 — Install Outside Air Hood (Factory Option)

The outside air hood for the factory-option economizer is shipped in knock-down form and requires field assembly. The panel for the hood top is shipped on the end of the unit (see Fig. 24). The remaining parts for the hood assembly (including side panels, filters and tracks) are shipped in a carton that is secured to the rear of the blower assembly. Access the carton location through rear panel (see Fig. 25).

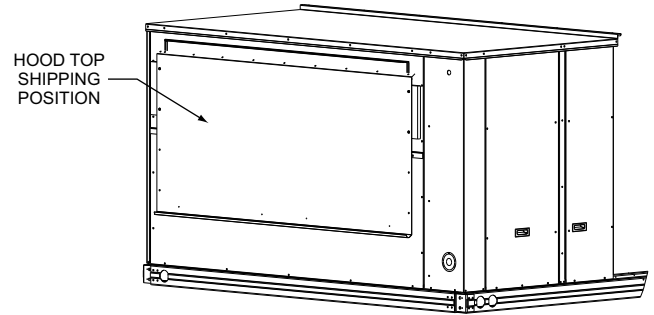

Fig. 24 — Hood Top — Shipping Position

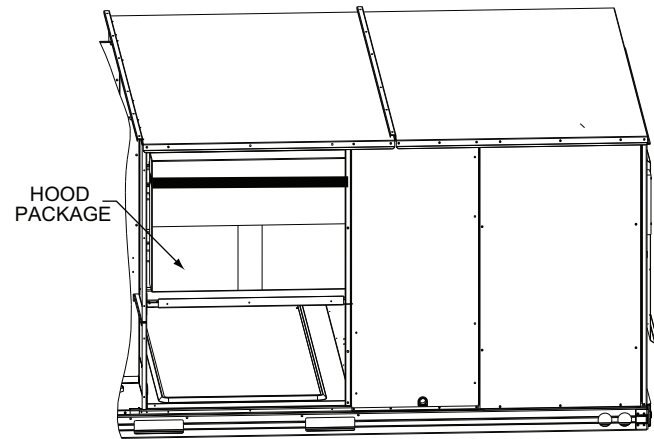

Fig. 25 — Hood Package — Shipping Location

To remove the hood parts package:

1. Remove the back blower access panel.
2. Locate and cut the strap, being careful to not damage any wiring.
3. Carefully lift the hood package carton through the back blower access opening.

To assemble the outside air hood (see Fig. 26 for hood component locations):

1. Remove hood top panel from shipping position on unit end.
2. Install filters supports (Item #1) to the upper end panel using the screws provided.
3. Install each deflector (Item #8) on to each filter support (Item #1) using the screws provided.
4. Apply seal strip to mating flanges on side plates of hood (Items #4 and #5).
5. Secure side panels (Items #4 and #5) to upper panel using the screws provided.
6. Apply seal strip to mating flange of the hood (see Fig. 26).
7. Secure hood top (Item #3) to upper panel using the screws provided. (On 44-in. chassis, remove the screws from across top cover of unit. The rear flange of hood top will slide behind unit top over flange.)
8. Secure side retainers (Item #6) to side panels (Items #4 and #5) using the screws provided, screwing from outside of the hood.
9. Secure each central retainer (Item #2) to the hood top (Item #3). Then align central retainers to holes located on filter support (Item #1), so central retainer is perpendicular to hood and each filter support. Secure using screws provided.
10. Apply seal strip to top diverters (Item #7).
11. Secure top diverters (Item #7) to hood top (Item #3).
12. Install outdoor air screens by sliding them into each of the four spaces created by the hood, filter support and central retainers. To do so, first insert the air screens into pocket created at the end of hood (Item #3), then fully put the air

screen into place, and then slide them back into pocket created in the filter support (Item #1). Repeat this for each air screen (see Fig. 27). See Fig. 28 for completed hood assembly.

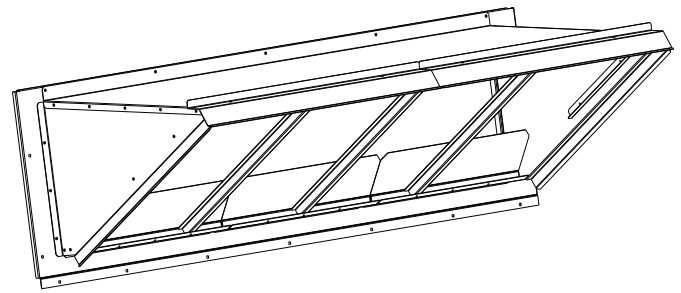
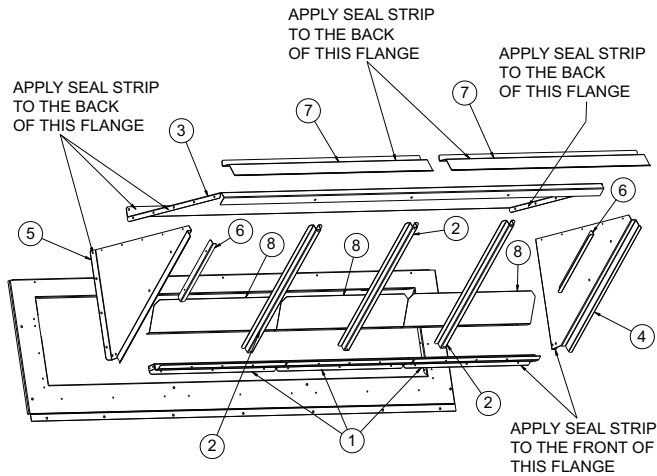

Fig. 28 — Completed Hood Assembly

Step 9 — Assemble Barometric Hood

The barometric hood can be assembled in vertical or horizontal configuration. Figure 29 illustrates the barometric hood parts.

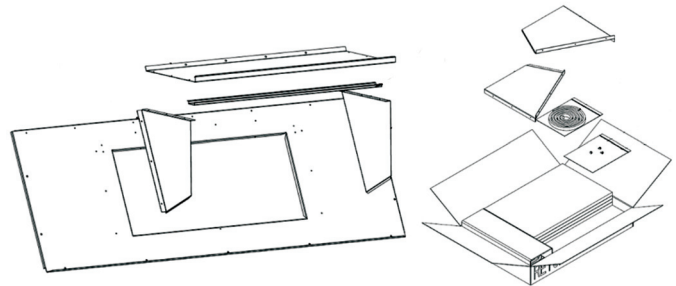

Fig. 29 — Barometric Hood Parts

BAROMETRIC HOOD (VERTICAL CONFIGURATION)

1. Remove the hood top panel from its shipping position on the unit end (see Fig. 30).

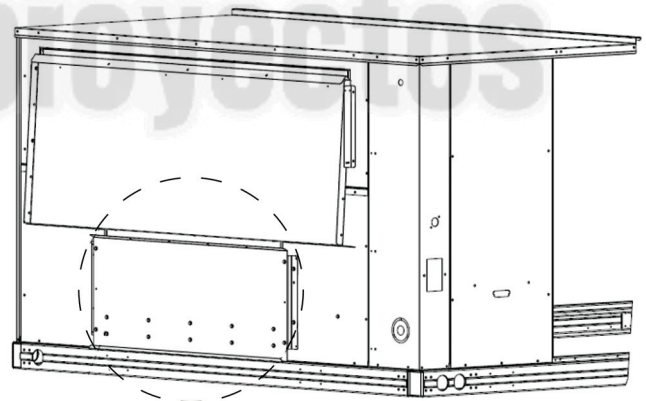

Fig. 30 — Shipping Location, Vertical Units

2. Remove the side panels located in the hood parts box (see Fig. 31).

ITEM #	DESCRIPTION	QTY
1	Filter Supports	3
2	Central Retainer	3
3	Hood Top	1
4	Left Hood Side	1
5	Right Hood Side	1
6	Side Retainer	2
7	Top Diverters	2
8	Deflector	3

Fig. 26 — Hood Part Identification and Seal Strip Application Areas

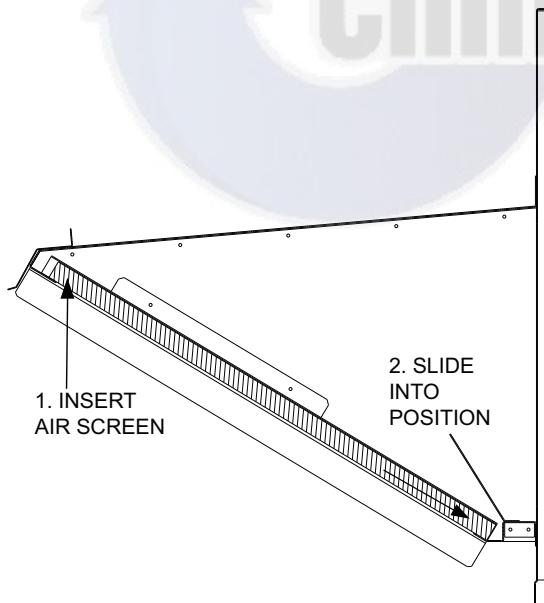

Fig. 27 — Outdoor Air Screen Installation

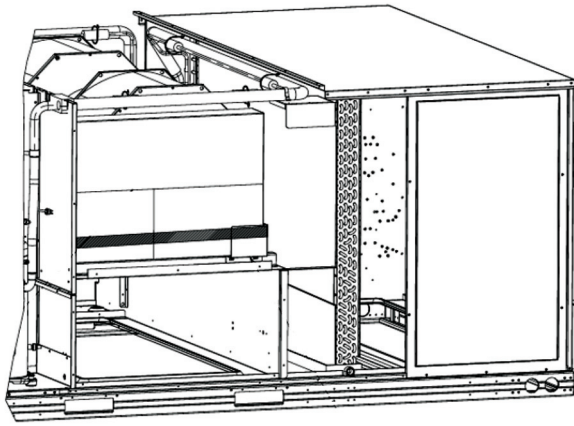

Fig. 31 — Barometric Hood Box Parts Location

3. Install parts as shown in the following exploded view (Fig. 32) using the seal strip and screws provided in the parts box.

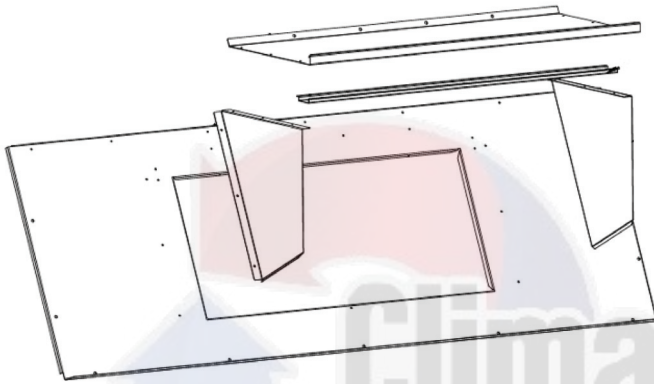

Fig. 32 — Barometric Hood Exploded View

Figure 33 illustrates the installed barometric hood parts.

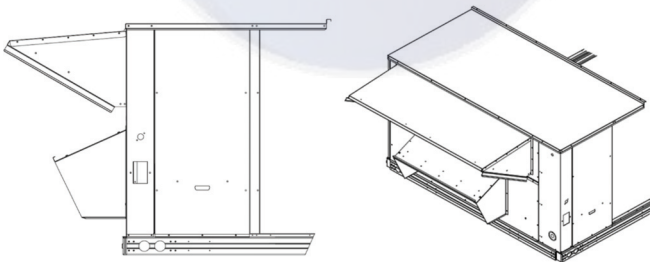

Fig. 33 — Installed Barometric Hood Side View and Isometric View

BAROMETRIC HOOD (HORIZONTAL CONFIGURATION)

For horizontal return and field installed economizer, install the economizer as follows:

1. Install the field provided horizontal ductwork onto the unit. Duct height must be at least 19 1/2 inches high, however the duct can be no taller than the top of the relief opening in the bottom panel, or airflow into the outside air hood will be restricted. See Fig. 34.

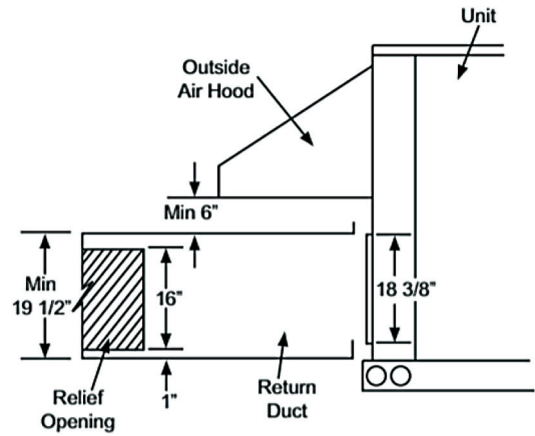
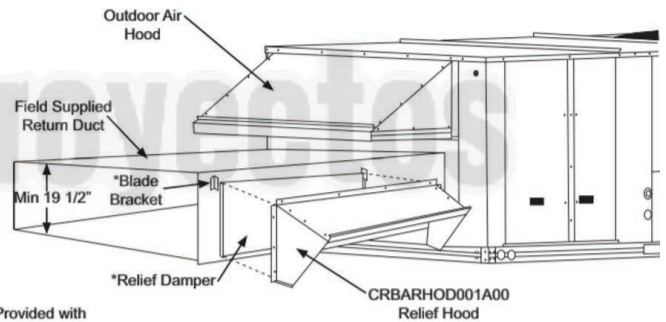

Fig. 34 — Relief Damper

2. Cut a 16 in. x 36 in. opening in the return duct for the relief damper (see Fig. 34).
3. On the field installed economizer (CRECOMZR0**A00), a birdscreen or hardware cloth is shipped attached to the bottom panel used for vertical applications.

NOTE: This panel is not used for horizontal return applications. Remove the screen from the provided panel and install it over the relief opening cut in return duct.

4. Using the blade brackets, install the relief damper onto the side of the return duct (see Fig. 35). The two brackets and relief damper are provided with the economizer.



*Provided with Economizer

Fig. 35 — Installing CRBARHOD001A00 Over Relief Damper

5. Using the provided hardware, screw the CRBARHOD001A00 hood sides and top together (see Fig. 36).

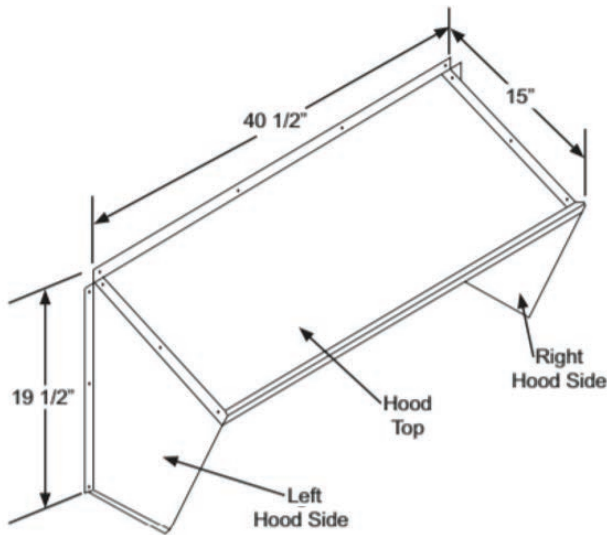

Fig. 36 — CRBARHOD001A00 Hood Sides and Top

Caulk the backside of the mating flanges to ensure a watertight seal. Install the CRBARHOD001A00 over the relief damper and screw to the return duct, as illustrated in Fig. 35.

Step 10 — Economizer – Horizontal Airflow Units

The barometric relief damper ships attached to the exterior return opening panel on the unit. See Fig. 37. Remove shipping cover to access the barometric relief damper, rain angle, and parts bag. These items are to be repositioned on the side of the field supplied ductwork. In addition, the barometric relief hood should be used and can be ordered separately (P/N CRBARHOD001A00) or can be field supplied.

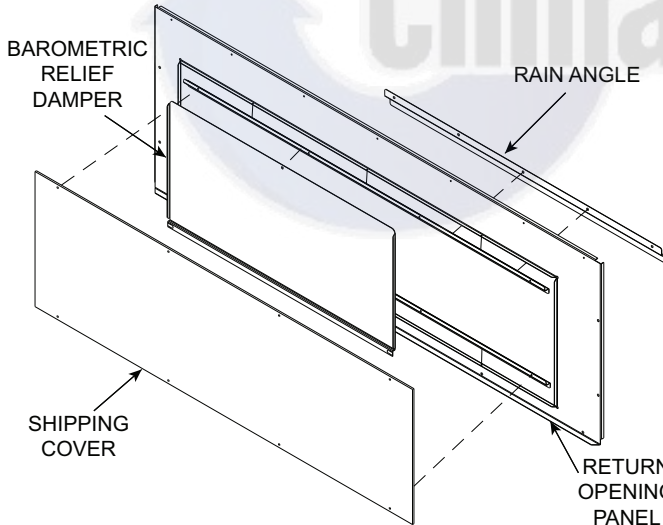

Fig. 37 — Barometric Relief Damper — Shipping Location

Step 11 — Install External Condensate Trap/Line

The unit has one 3/4-in. condensate drain connection on the end of the condensate pan. See Fig. 38. See Fig. 4, 9, and 14, Item E in the view labeled “BACK (HORIZONTAL DISCHARGE W/O ECON)” for the location of the condensate drain connection.

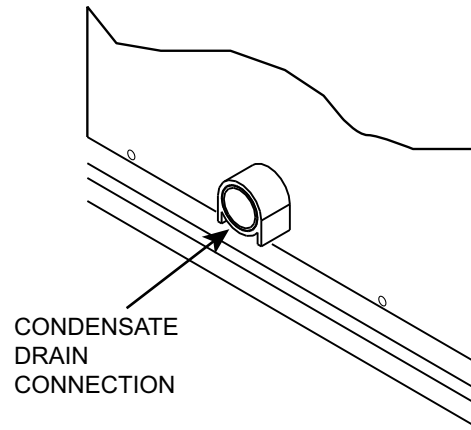
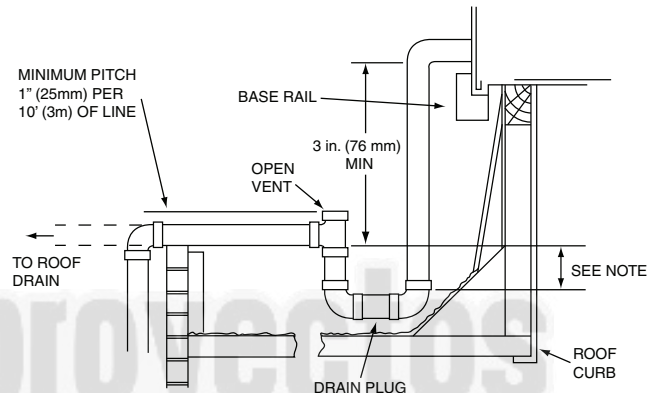

Fig. 38 — Condensate Drain Pan Connection

The piping for the condensate drain and external trap can be completed after the unit is in place. Hand-tighten fittings to the drain pan fitting. Provide adequate support for the drain line. Failure to do so can result in damage to the drain pan. See Fig. 39.



NOTE: Trap should be deep enough to offset maximum unit static difference. A 4-in. (102 mm) trap is recommended.

Fig. 39 — Condensate Drain Pan Piping Details

All units must have an external trap for condensate drainage. Install a trap at least 4-in. (102 mm) deep and protect against freeze-up. If drain line is installed downstream from the external trap, pitch the line away from the unit at 1-in. per 10 ft (25 mm per 3 m) of run. Do not use a pipe size smaller than the unit connection (3/4-in.).

Step 12 — Make Electrical Connections

⚠ WARNING

ELECTRIC SHOCK HAZARD

Failure to follow this warning could result in personal injury or death.

Unit cabinet must have an uninterrupted, unbroken electrical ground to minimize the possibility of personal injury if an electrical fault should occur. This ground may consist of electrical wire connected to unit ground lug in control compartment, or conduit approved for electrical ground when installed in accordance with NEC; ANSI/NFPA 70, latest edition (in Canada, Canadian Electrical Code CSA [Canadian Standards Association] C22.1), and local electrical codes.

NOTE: Field-supplied wiring shall conform with the limitations of minimum 63°F (33°C) rise.

FIELD POWER SUPPLY

If equipped with optional powered convenience outlet: the power source leads to the convenience outlet's transformer primary are not factory connected. Installer must connect these leads according to required operation of the convenience outlet. If an always-energized convenience outlet operation is desired, connect the source leads to the line side of the unit-mounted disconnect. (Check with local codes to ensure this method is acceptable in your area.) If a de-energize via unit disconnect switch operation of the convenience outlet is desired, connect the source leads to the load side of the unit disconnect. On a unit without a unit-mounted disconnect or HACR, connect the source leads to the terminal block with unit field power leads. See Fig. 40.

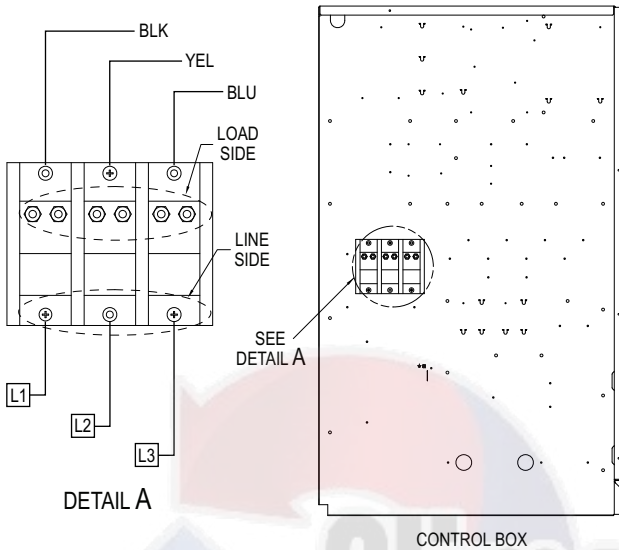

Fig. 40 — Location of TB1

Field power wires are connected to the unit at line-side pressure lugs on the terminal block (see wiring diagram label for control box component arrangement) or at factory-installed option non-fused disconnect switch or HACR breaker. Use copper conductors only. See Fig. 41.

Figure 42-48 are typical control and power wiring diagrams.

NOTE: Make field power connections directly to line connection pressure lugs only.

⚠ WARNING

FIRE HAZARD

Failure to follow this warning could result in personal injury, death, or property damage.

Do not connect aluminum wire between disconnect switch and unit. Use only copper wire.

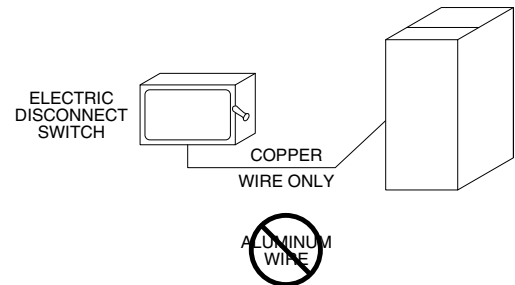

Fig. 41 — Disconnect Switch and Unit

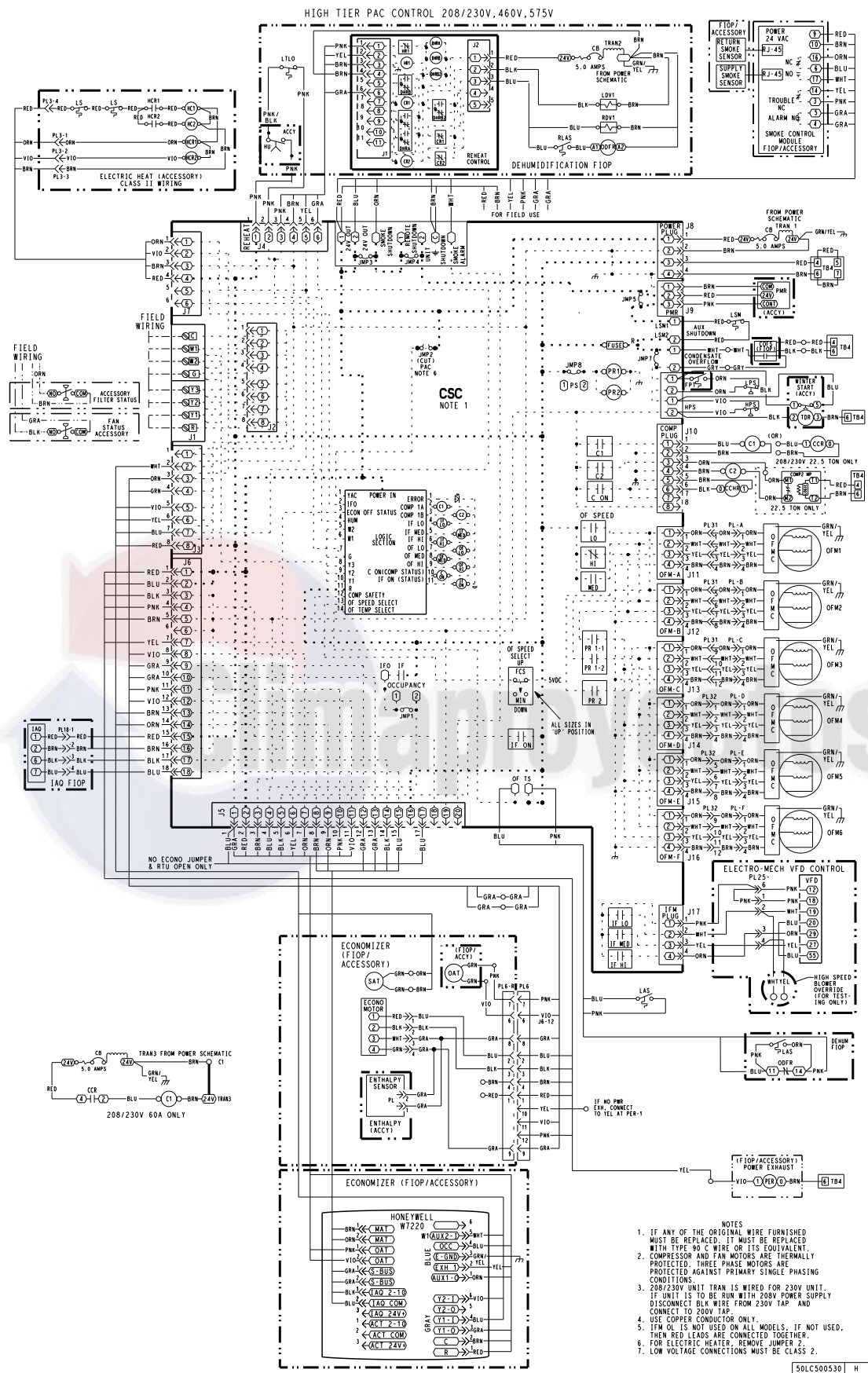

Fig. 42 — 50LC 14-26 Electro-Mechanical Control Wiring Diagram

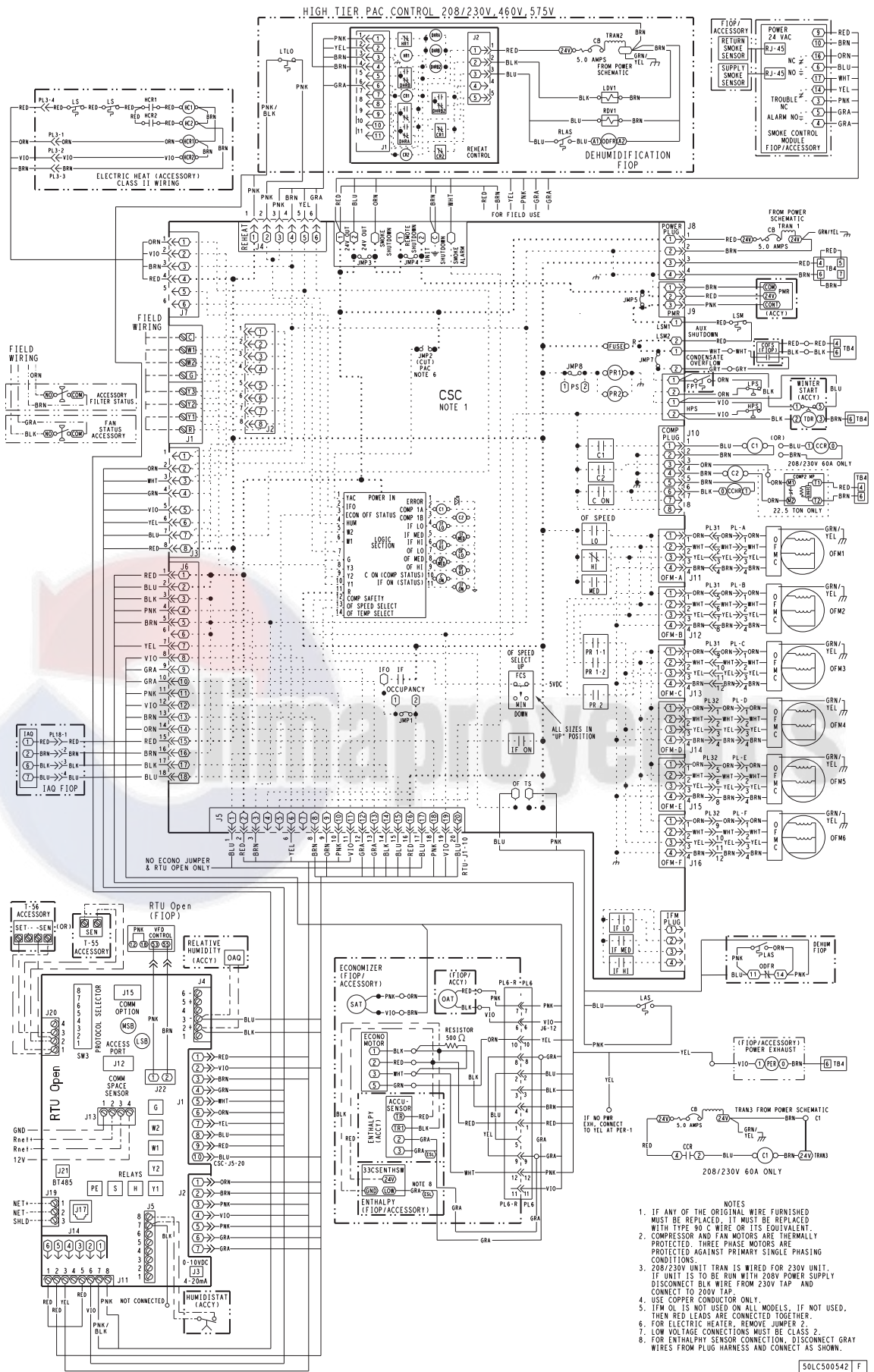

Fig. 43 — 50LC 14-26 RTU Open Control Wiring Diagram

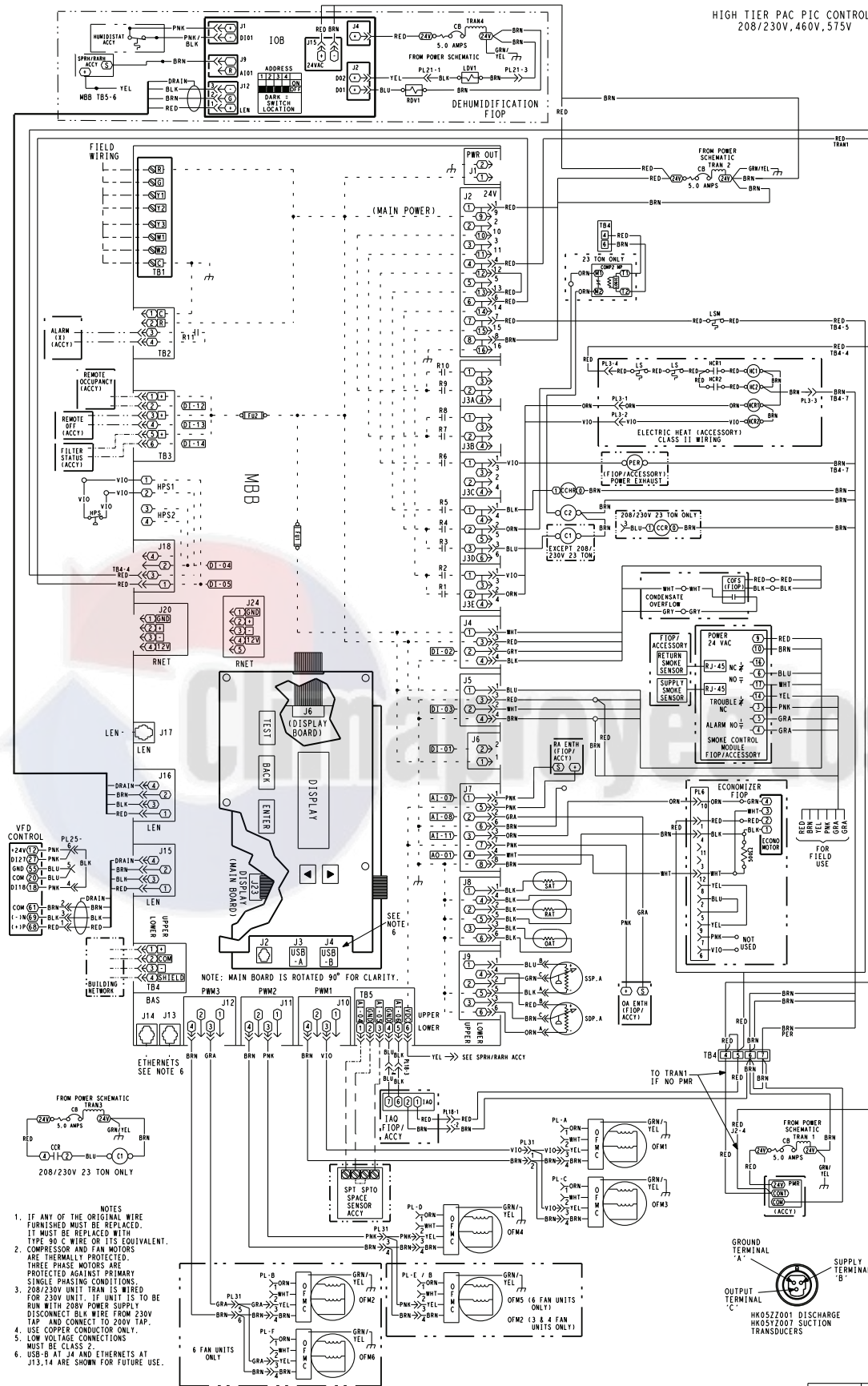

Fig. 44 — 50LC 14-26 SystemVu™ Control Wiring Diagram

50LC50083 F

12.5 - 20 TON YAC, PAC POWER 208/230V 3 PH WITH/WITHOUT HOT GAS REHEAT FIOP

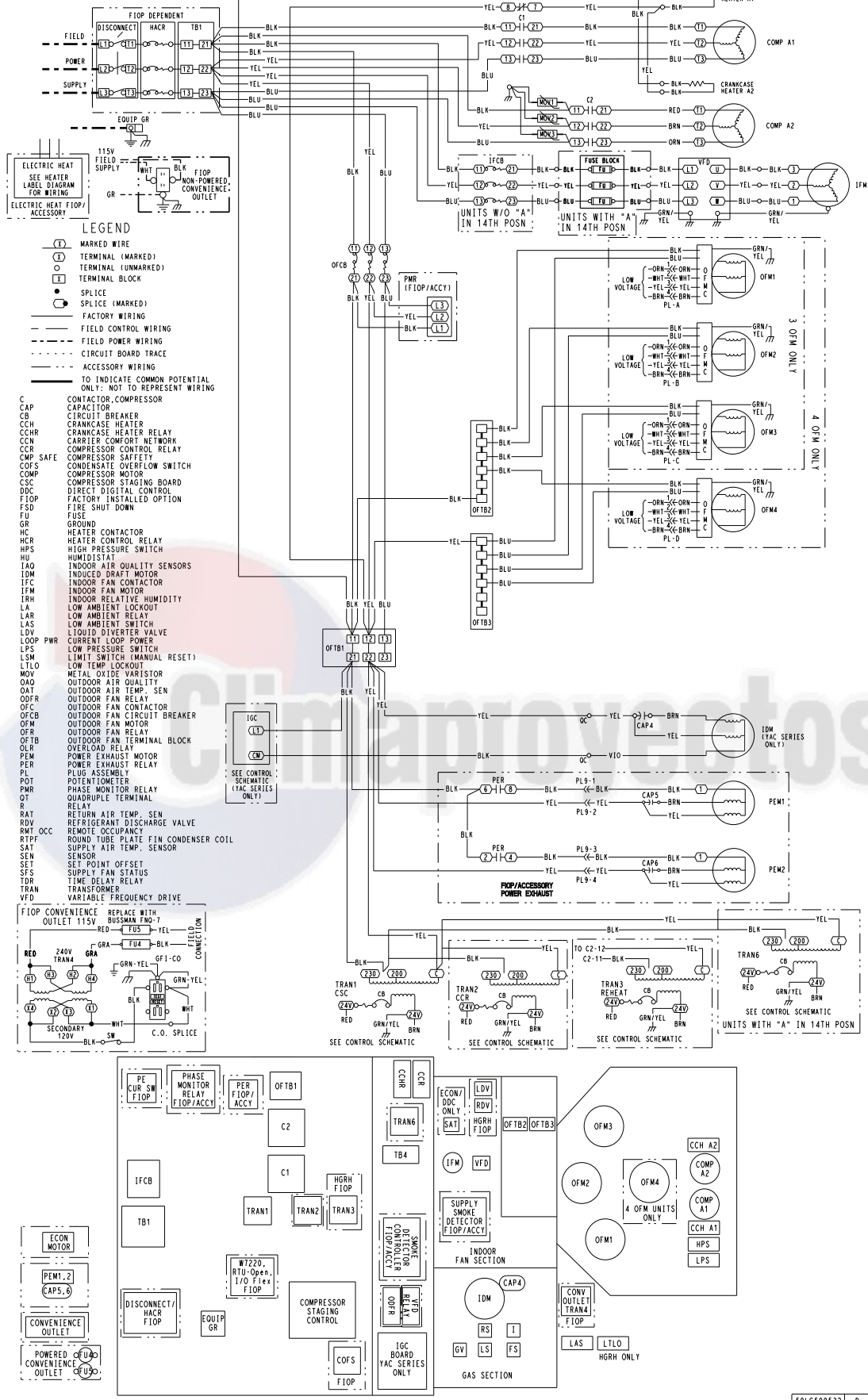

Fig. 45 — Typical Power Wiring Diagram Electro-Mechanical and RTU Open Controls, 50LC 14-24 Units 208/230V Shown

12.5 - 22.5 TON YAC, PAC POWER 460,575V 3 PH
WITH/WITHOUT HOT GAS REHEAT FIOP

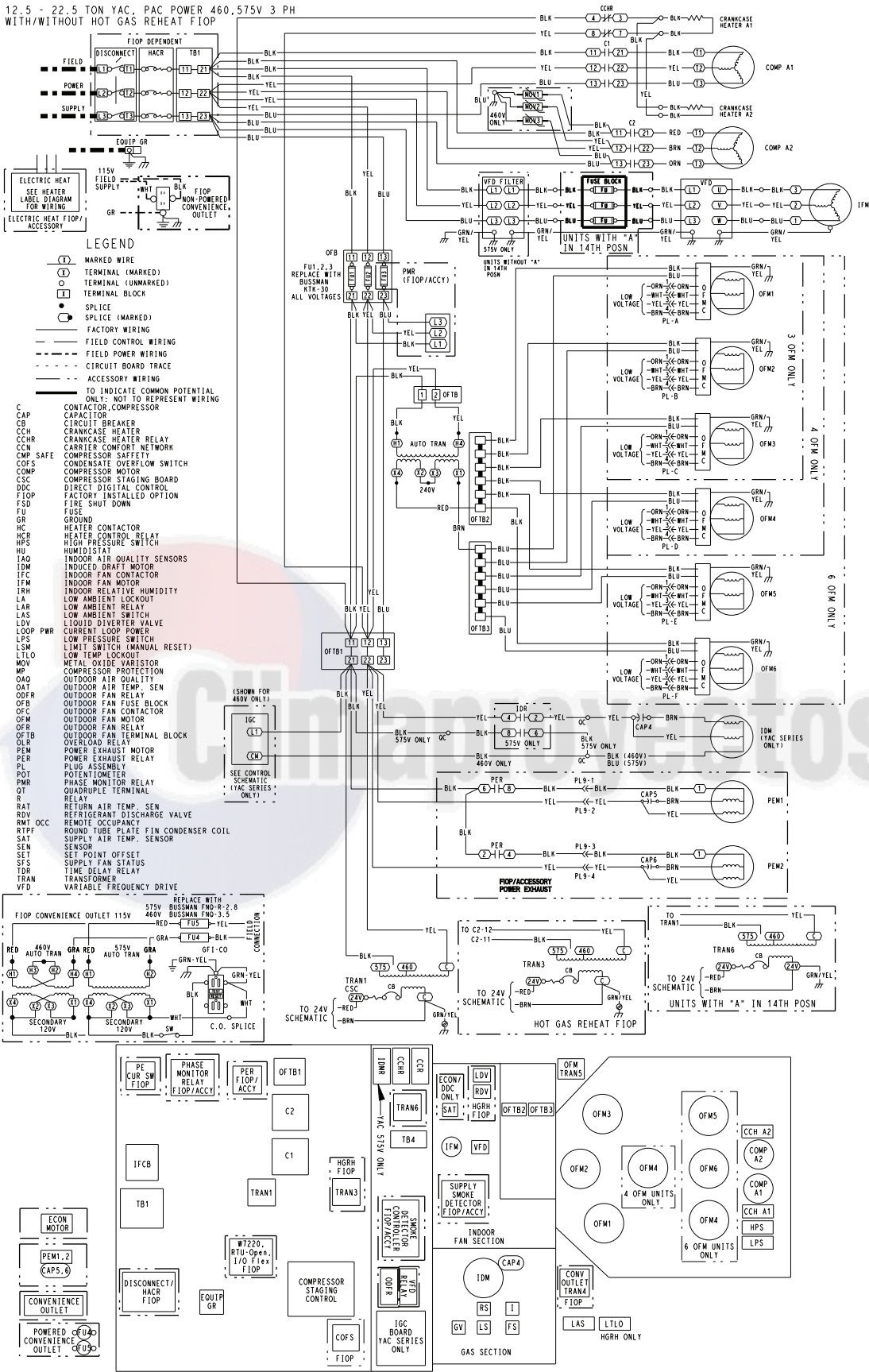

Fig. 46 — Typical Power Wiring Diagram Electro-Mechanical and RTU Open Controls, 50LC 15-24 Units 460V, 575V Shown

23 TON YAC, PAC POWER
208/230V 3 PH

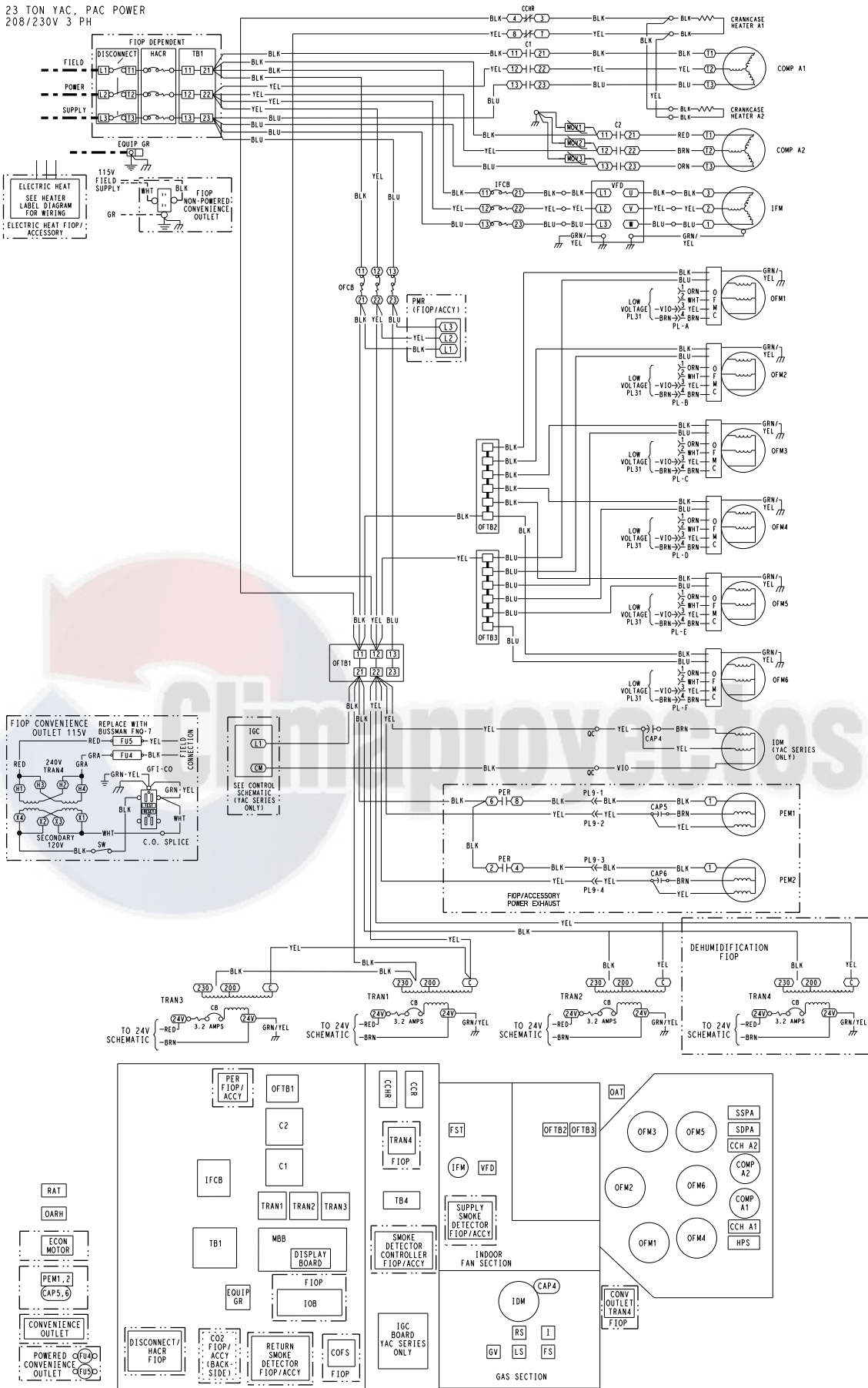

Fig. 47 — Typical Power Wiring Diagram, SystemVu™ Controls, 50LC Unit 208/230V Shown

12.5 - 23 TON YAC, PAC POWER
460, 575V 3 PH

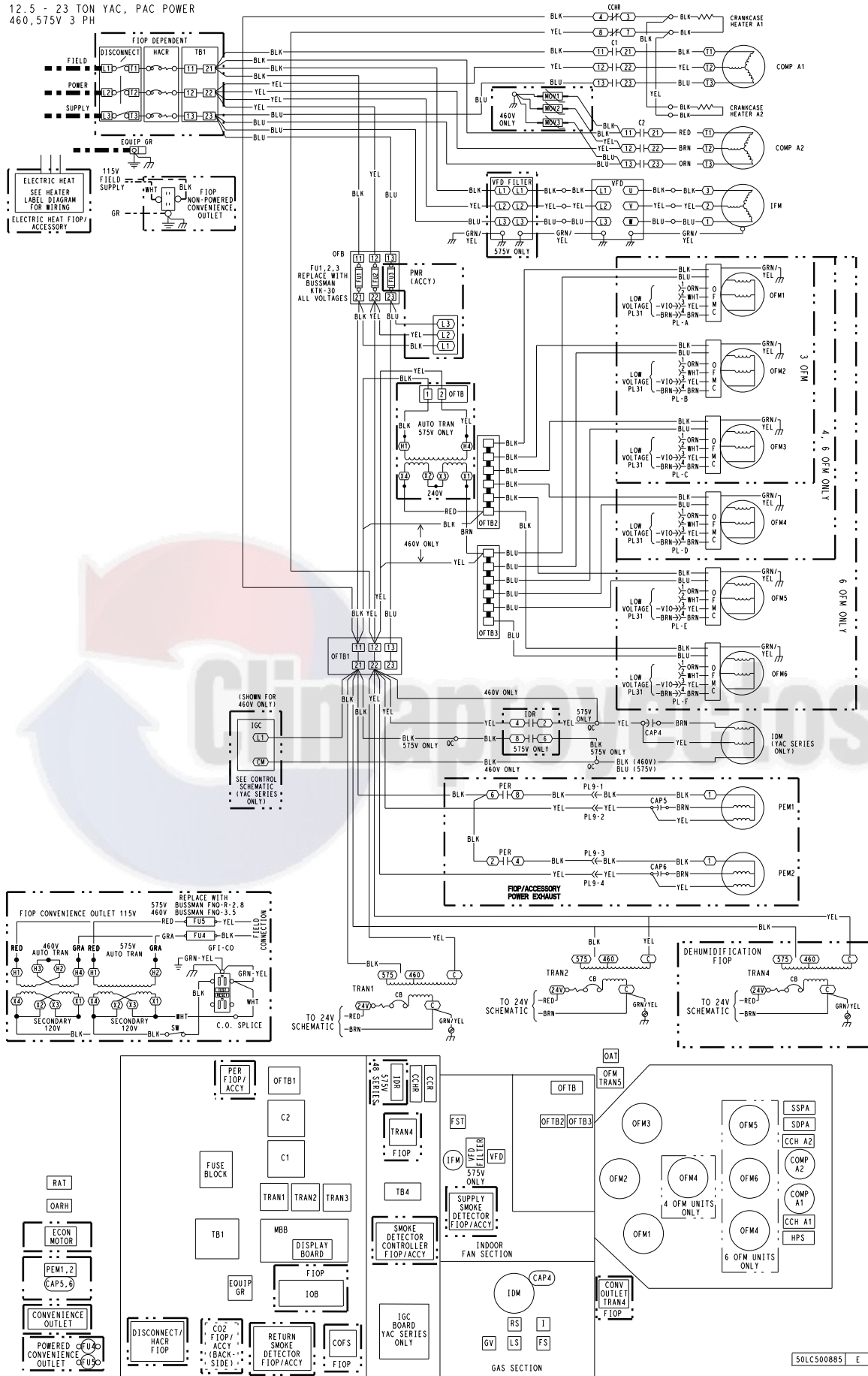

Fig. 48 — Typical Power Wiring Diagram, SystemVu™ Controls, 50LC Unit 460V, 575V Shown

UNITS WITHOUT FACTORY-INSTALLED NON-FUSED DISCONNECT OR HACR

When installing units, provide a disconnect switch per NEC (National Electrical Code) of adequate size. Disconnect sizing data is provided on the unit informative plate. Locate on unit cabinet or within sight of the unit per national or local codes. Do not cover unit informative plate if mounting the disconnect on the unit cabinet.

UNITS WITH FACTORY-INSTALLED NON-FUSED DISCONNECT OR HACR

The factory-installed optional non-fused disconnect (NFD) or HACR switch is located in the main control box. The manual switch handle and shaft are shipped in the control box and must be mounted on the corner post adjacent to the control box (see Fig. 49 or 50). Note that the tape covering the hole for the shaft in the corner post must be removed prior to handle and shaft installation.

Field-Install the NFD Shaft and Handle

1. Open the control box panel.
2. Make sure the NFD shipped from the factory is at OFF position (the arrow on the black handle knob or on the silver metal collar is at OFF).
3. Insert the shaft with the cross pin on the top of the shaft in the horizontal position.
4. Measure the tip of the shaft to the outside surface of the corner post to be 0.88-in.
5. Tighten the locking screw to secure the shaft to the NFD.
6. Turn the handle to OFF position with red arrow pointing at OFF.
7. Install the handle on to the corner post vertically with the red arrow pointing up.
8. Secure the handle to the corner post with (2) screws and lock washers supplied.

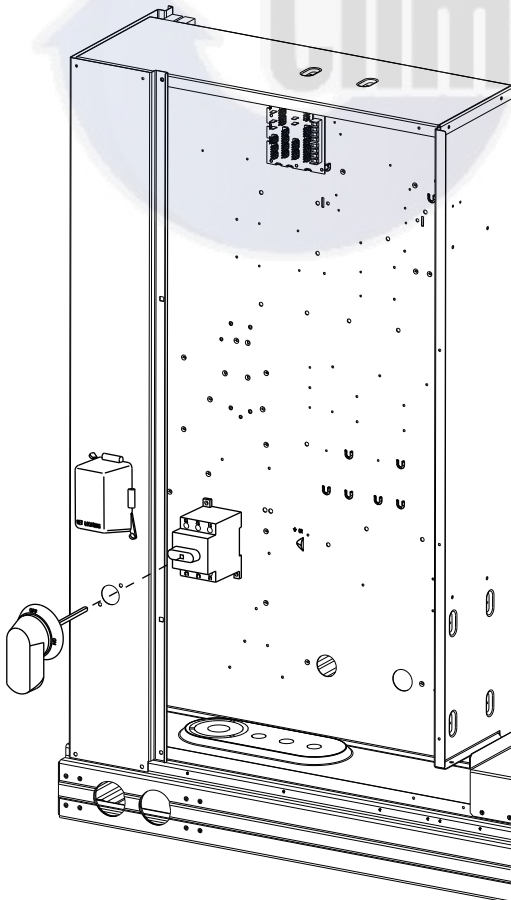

Fig. 49 — Handle and Shaft Assembly for NFD

Field-Install the HACR Shaft and Handle

1. Open the control box panel.
2. Make sure the HACR shipped from the factory is at OFF position (the white arrow pointing at OFF).
3. Insert the shaft with the cross pin on the top of the shaft in the horizontal position.
4. Measure the tip of the shaft to the outside surface of the corner post to be 0.88-in.
5. Tighten the locking screw to secure the shaft to the HACR.
6. Turn the handle to OFF position with red arrow pointing at OFF.
7. Install the handle on to the corner post vertically with the red arrow pointing up.
8. Secure the handle to the corner post with (2) screws and lock washers supplied.

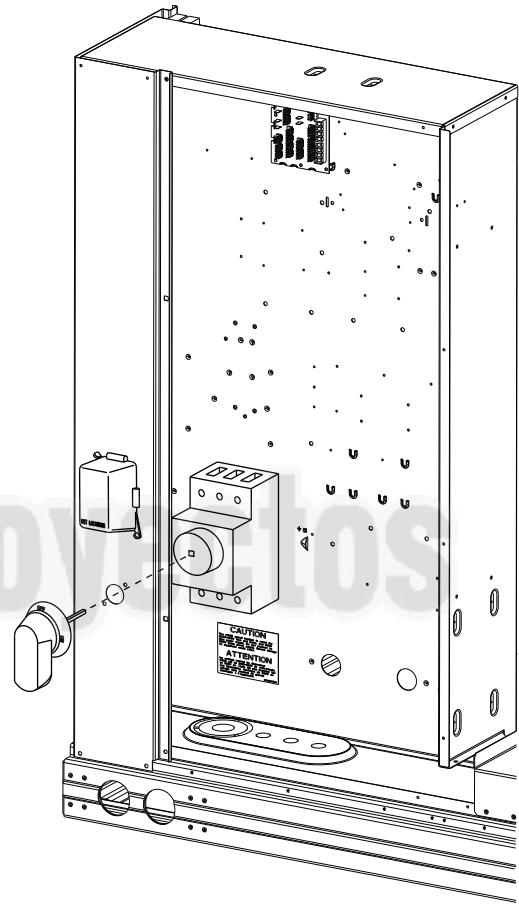

Fig. 50 — Handle and Shaft Assembly for HACR

ALL UNITS

All field wiring must comply with NEC and all local code requirements.

Size wire based on MCA (Minimum Circuit Amps) on the unit informative plate. See Fig. 51 for power wiring connections to the unit power terminal block and equipment ground. Maximum wire size is 2/0 AWG per pole.

Provide a ground-fault and short-circuit over-current protection device (fuse or breaker) per NEC Article 440 (or local codes). Refer to unit informative data plate for MOCP (Maximum Over-current Protection) device size.

Units ordered with factory-installed HACR do not need additional ground-fault and short circuit over current protection device unless required by local codes.

Voltage to compressor terminals during operation must be within voltage range indicated on unit nameplate. On 3-phase units, voltages between phases must be balanced within 2% and the current within 10%. Use the formula shown in the example below to determine the percent of voltage imbalance. Operation on improper line voltage or excessive phase imbalance constitutes abuse and may cause damage to electrical components. Such operation would invalidate any applicable Carrier warranty.

Example: Supply voltage is 230-3-60

$$\% \text{ Voltage Imbalance} = 100 \times \frac{\text{max voltage deviation from average voltage}}{\text{average voltage}}$$

Example: Supply voltage is 230-3-60



AB = 224 v
BC = 231 v
AC = 226 v

$$\text{Average Voltage} = \frac{(224 + 231 + 226)}{3} = \frac{681}{3} = 227$$

Determine maximum deviation from average voltage.

(AB) 227-224 = 3 v

(BC) 231-227 = 4 v

(AC) 227-226 = 1 v

Maximum deviation is 4 v.

Determine percent of voltage imbalance.

$$\% \text{ Voltage Imbalance} = 100 \times \frac{4}{227} = 1.78\%$$

This amount of phase imbalance is satisfactory as it is below the maximum allowable 2%.

IMPORTANT: If the supply voltage phase imbalance is more than 2%, contact your local electric utility company immediately.

⚠ CAUTION

UNIT DAMAGE HAZARD

Failure to follow this caution may result in equipment damage. Operation on improper line voltage or excessive phase imbalance constitutes abuse and may cause damage to electrical components. Such operation would invalidate any applicable Carrier warranty.

Units Without Disconnect or HACR Option

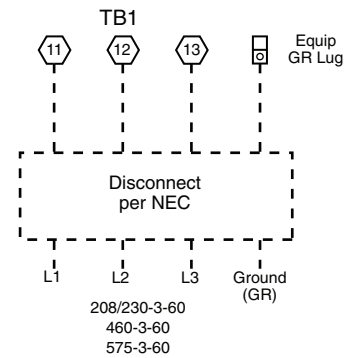

Units With Disconnect or HACR Option

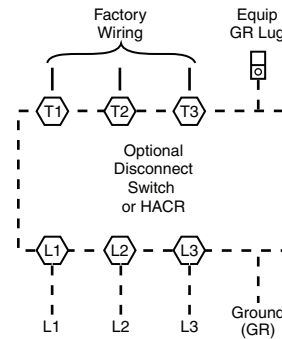

Fig. 51 — Power Wiring Connections

CONVENIENCE OUTLETS

⚠ WARNING

ELECTRICAL OPERATION HAZARD

Failure to follow this warning could result in personal injury or death.

Units with convenience outlet circuits may use multiple disconnects. Check convenience outlet for power status before opening unit for service. Locate its disconnect switch, if appropriate, and open it. Lock-out and tag-out this switch, if necessary.

Two types of convenience outlets are offered on 50LC models: non unit-powered and unit-powered. Both types provide a 125-v GFCI (ground-fault circuit interrupter) duplex receptacle rated at 15A behind a hinged waterproof access cover, located on the end panel of the unit. See Fig. 52.

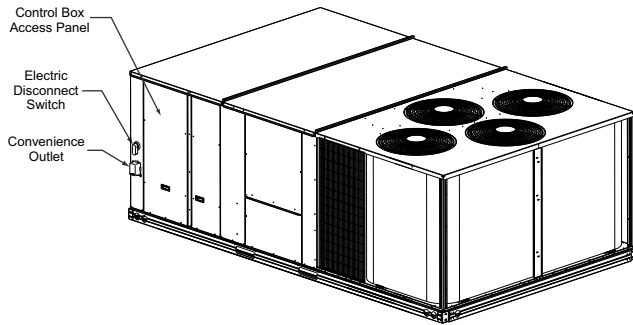

Fig. 52 — Convenience Outlet Location

Installing Weatherproof Cover

A weatherproof while-in-use cover for the factory-installed convenience outlets is now required by UL standards. This cover cannot be factory-mounted due its depth; it must be installed at unit installation. For shipment, the convenience outlet is covered with a blank cover plate.

The weatherproof cover kit is shipped in the unit’s control box. The kit includes the hinged cover, a backing plate, and gasket.

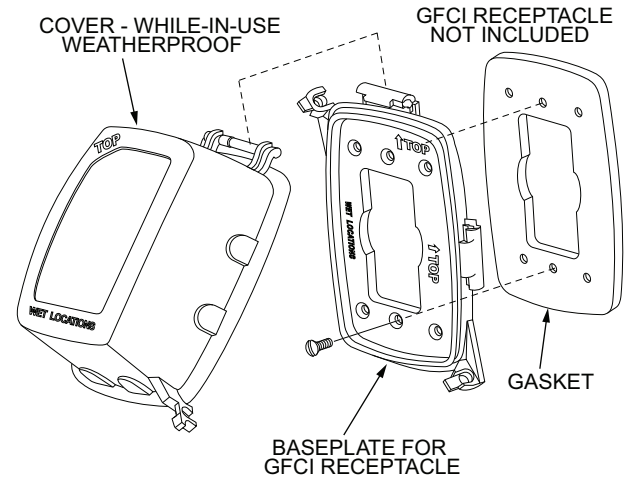

Fig. 53 — Weatherproof Cover Installation

Non-Unit Powered Convenience Outlet

This type requires the field installation of a general-purpose 125-v 15A circuit powered from a source elsewhere in the building. Observe national and local codes when selecting wire size, fuse or breaker requirements, and disconnect switch size and location. Route 125v power supply conductors into the bottom of the utility box containing the duplex receptacle.

Unit-Powered Convenience Outlet

A unit-mounted transformer is factory-installed to step down the main power supply voltage to the unit to 115v at the duplex receptacle. This option also includes a manual switch with fuse, located in a utility box and mounted on a bracket behind the convenience outlet; access is through the unit’s control box access panel. See Fig. 52.

The primary leads to the convenience outlet transformer are not factory-connected. If local codes permit, the transformer primary leads can be connected at the line-side terminals on the unit-mounted non-fused disconnect or HACR breaker switch; this will provide service power to the unit when the unit disconnect switch or HACR switch is open. Other connection methods will result in the convenience outlet circuit being de-energized when the unit disconnect or HACR switch is open. See Fig. 54.

⚠ WARNING

PERSONAL INJURY HAZARD

Failure to follow this caution could result in personal injury or death.

Disconnect all power to unit and convenience outlet. Lock-out and tag-out all power.

1. Remove the blank cover plate at the convenience outlet; discard the blank cover.
2. Loosen the two screws at the GFCI duplex outlet, until approximately 1/2-in. (13 mm) under screw heads is exposed. Press the gasket over the screw heads.
3. Slip the backing plate over the screw heads at the keyhole slots and align with the gasket; tighten the two screws until snug (do not over-tighten).
4. Mount the weatherproof cover to the backing plate as shown in Fig. 53.
5. Remove two slot fillers in the bottom of the cover to permit service tool cords to exit the cover.
6. Check for full closing and latching.

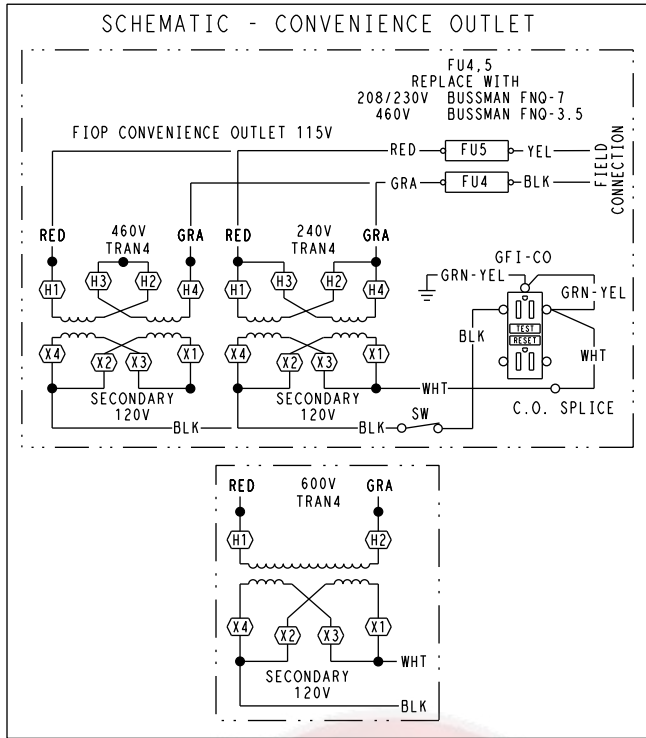

UNIT VOLTAGE	CONNECT AS	PRIMARY CONNECTIONS	TRANSFORMER TERMINALS
208, 230	240	L1: RED + YEL L2: BLU + GRA	H1 + H3 H2 + H4
460	480	L1: RED Splice BLU + YEL L2: GRA	H1 H2 + H3 H4
575	600	L1: RED L2: GRA	H1 H2

Fig. 54 — Powered Convenience Outlet Wiring

Test the GFCI receptacle by pressing the TEST button on the face of the receptacle to trip and open the receptacle. Check for proper grounding wires and power line phasing if the GFCI receptacle does not trip as required. Press the RESET button to clear the tripped condition.

Using Unit-Mounted Convenience Outlets

Units with unit-mounted convenience outlet circuits will often require that two disconnects be opened to de-energize all power to the unit. Treat all units as electrically energized until the convenience outlet power is also checked and de-energization is confirmed. Observe National Electrical Code Article 210, Branch Circuits, for use of convenience outlets.

Duty Cycle

The unit-powered convenience outlet has a duty cycle limitation. The transformer is intended to provide power on an intermittent basis for service tools, lamps, etc; it is not intended to provide 15 amps loading for continuous duty loads (such as electric heaters for overnight use). Observe a 50% limit on circuit loading above 8 amps. Convenience outlet usage rating:

- Continuous usage: 8 amps maximum
- Intermittent usage: Up to 15 amps maximum for up to 2 hours maximum

See Fig. 55.

NOTICE/AVIS

Convenience Outlet Utilization
 Maximum Intermittent Use 15 - Amps
 Maximum Continuous Use 8 - Amps
 Observe a 50% limit on the circuit Loading above 8 - Amps

Utilisation de la prise utilitaire
 Usage intermittent maximum 15 - Amps
 Usage continu maximum 8 - Amps
 Observez une limite de 50% sur le circuit
 Chargement au-dessus de 8 - Amps

50HE501288 | 2.0

Fig. 55 — Convenience Outlet Utilization Notice Label

HACR AMP RATING

The amp rating of the HACR factory-installed option is based on the size, voltage, indoor motor and other electrical options of the unit as shipped from the factory. If field-installed accessories are added or changed in the field (for example, electric heat, power exhaust), the HACR may no longer be of the proper amp rating and therefore will need to be removed from the unit. See unit nameplate and label on factory-installed HACR for the amp rating of the HACR that was shipped with the unit from the factory (Fig. 56). See unit nameplates for the proper fuse, HACR or maximum over-current protection device required on the unit with field installed accessories.

⚠ CAUTION

The HACR circuit breaker is rated for 240V/480V Wye and Delta, and 600V Wye power supply. Do not connect to 600V Delta power supply. Severe damage to equipment would occur.

⚠ ATTENTION

Le voltage nominal du disjoncteur CACR est de 240V/480V en étoile-triangle, et 600V en étoile. Ne pas brancher sur une alimentation électrique de 600V en triangle. Cela causera de graves dommages à l'équipement.

48TM503700 | -

Fig. 56 — HACR Caution Label

FACTORY-OPTION THRU-BASE ELECTRICAL CONNECTIONS

All units are equipped with the ability to bring utilities through the base.

The electrical entrance is located in the control box area can be accessed through the control box access panel. An embossed area is provided with three knock outs. High voltage is brought through the multi knock out by removing the appropriate size for the size of the fitting required. A 7/8-in. knock out is provided for low voltage. An additional 7/8-in. knock out is provided for a 115-v line, which is used when the unit is equipped with the non-unit powered convenience outlet option.

All required fittings are field supplied. Install fittings when access to both top and bottom of the base pan is available.

UNITS WITHOUT THRU-BASE ELECTRICAL CONNECTIONS

1. Install liquid tight conduit between disconnect and control box.
2. Pull correctly rated high voltage wires through the conduit.
3. Install power lines to terminal connections as shown in Fig. 51 on page 38.

FIELD CONTROL WIRING

The 50LC size 14-26 units require an external temperature control device such as a thermostat (field-supplied).

THERMOSTAT

Install a Carrier approved accessory thermostat according to installation instructions included with the accessory. For complete economizer function and 3-stage compressor operation select a three-stage cooling thermostat. If a 3-stage cooling thermostat is not available, use a 2-stage cooling thermostat instead, but note that this will limit cooling to just 2 stages. When electric heat is installed in the 50LC size 14-26 units, the thermostat must be capable of energizing the G terminal (to energize the Indoor Fan Contactor) whenever there is a space call for heat (energizing the W1 terminal). The accessory thermostats listed on the unit price pages can provide this signal but they are not configured to enable this signal as shipped.

Locate the thermostat accessory on a solid wall in the conditioned space to sense average temperature in accordance with the thermostat installation instructions.

If the thermostat contains a logic circuit requiring 24-v power, use a thermostat cable or equivalent single leads of different colors with minimum of seven leads. If the thermostat does not require a 24-v source (no "C" connection required), use a thermostat cable or equivalent with minimum of six leads. See Fig. 57. Check the thermostat installation instructions for additional features which might require additional conductors in the cable.

For wire runs up to 50 ft. (15 m), use no. 18 AWG (American Wire Gage) insulated wire [35°C (95°F) minimum]. For 50 to 75 ft. (15 to 23 m), use no. 16 AWG insulated wire [35°C (95°F) minimum]. For over 75 ft. (23 m), use no. 14 AWG insulated wire [35°C (95°F) minimum]. Wire sizes larger than no. 18 AWG cannot be directly connected to the thermostat and will require a junction box and splice at the thermostat.

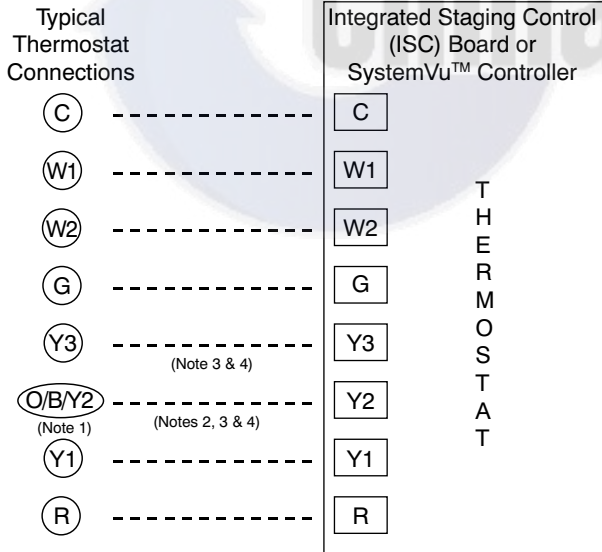

Note 1: Typical multi-function marking. Follow manufacturer's configuration Instructions to select Y2.

Note 2: Y2 to Y3 connection required for 2-stage cooling operation and when integrated economizer function is desired.

Note 3: To Connect a 2-Stage Thermostat:
Y2 to Y3 connection required for 2-stage cooling operation which provides low and high cooling states.

Note 4: SystemVu controller is default configured for 3-stage cooling and 2-stage heating thermostats; it can be configured for other thermostat types.

--- Field Wiring

Fig. 57 — Low-Voltage Thermostat Connections

UNITS WITHOUT THRU-BASE CONNECTION KIT

Correctly rated low voltage wire can be routed through the rubber grommet located on the corner post adjacent to the control box access panel. Route wire through the grommet and then route the wire behind the corner post utilizing the factory provided wire ties secured to the control box. This will ensure separation of the field low voltage wire and the high voltage circuit. Route the low voltage wire to the Integrated Staging Control (ISC) board. See Fig. 58.

NOTE: If utilizing the through the base connections, route the low voltage wire through the wire ties to the ISC board.

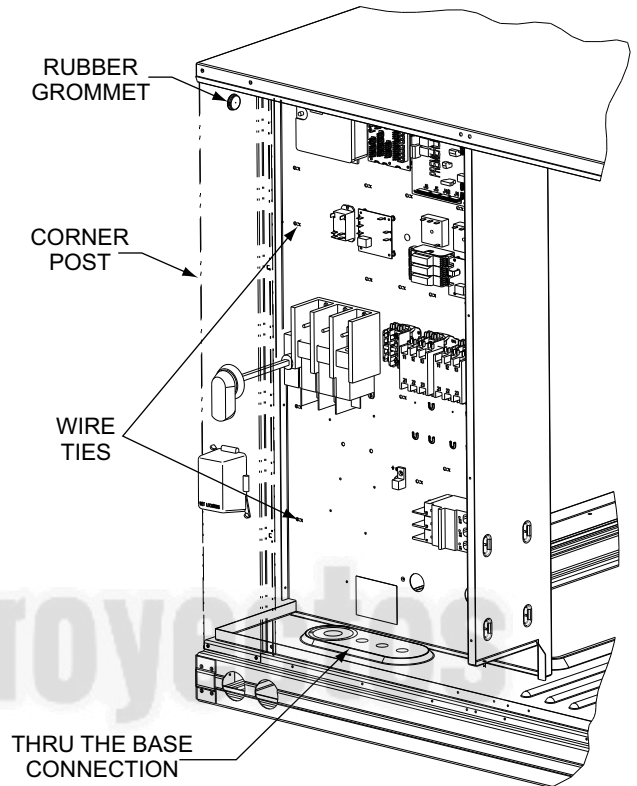

Fig. 58 — Field Control Wiring Raceway

CONFIGURING FOR ELECTRIC HEAT

To configure the factory-approved thermostat, open the Advanced Setup menu, scroll down to ELECTRIC HEAT and change RANGE value from OFF to ON. Consult the thermostat installation instructions for full details.

HEAT ANTICIPATOR SETTINGS

Set heat anticipator settings at 0.14 amp for the first stage and 0.14 amp for second-stage heating.

TRANSFORMER CONNECTION FOR 208-V POWER SUPPLY

All units except 208/230-v units are factory wired for the voltage shown on the nameplate. *If the 208/230-v unit is to be connected to a 208-v power supply, the control transformer must be rewired by moving the black wire with the 1/4-in. female spade connector from the 230-v connection and moving it to the 208-v 1/4-in. male terminal on the primary side of the transformer.* Refer to unit label diagram for additional information.

ELECTRIC HEATERS

The 50LC units may be equipped with factory or field-installed electric heaters. The heaters are modular in design.

Heater modules are installed in the compartment below the indoor blower access panel. Access is through the electric heat access panel. Heater modules slide into the compartment on tracks along the bottom of the heater opening. See Fig. 59-61. Refer to the Electric Heater Kit Installation Instructions for complete details on field-installed electric heat accessory.

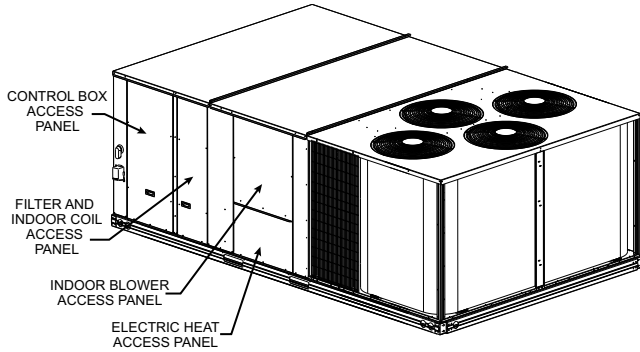

Fig. 59 — Typical Access Panel Location

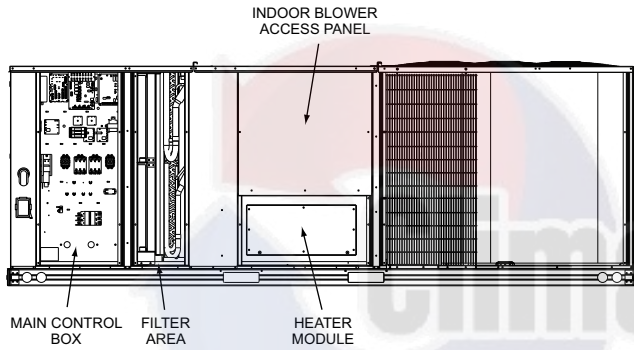

Fig. 60 — Typical Component Location

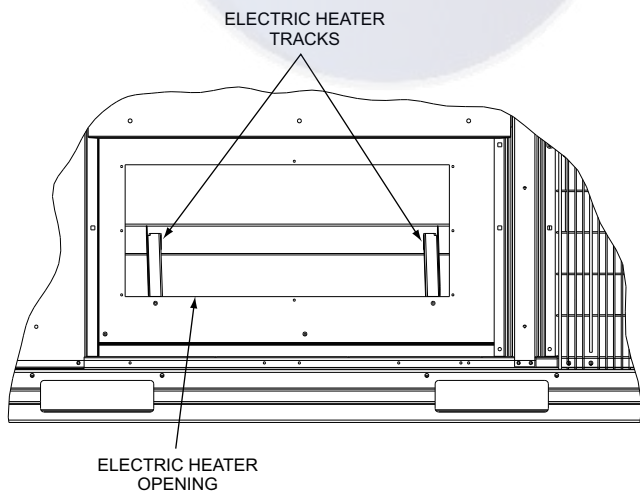

Fig. 61 — Electric Heater Compartment (Cover Removed)

Not all available heater modules may be used in every unit. Use only those heater modules that are ETL listed for use in a specific size unit. Refer to the label on the unit cabinet for the list of approved heaters.

Low-Voltage Control Connections

Locate the plug assembly in the electric heater section of the main unit. Connect the plug with the mating low voltage plug located on the heater. Note that the plug will already be connected when there is factory-installed electric heat. See Fig. 62.

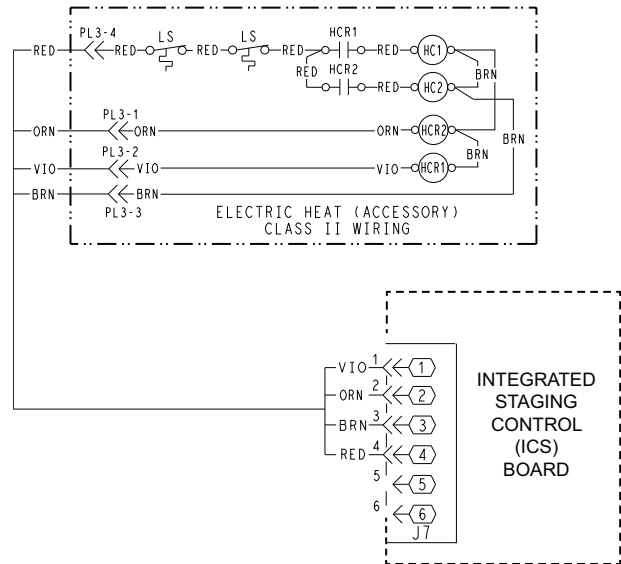

Fig. 62 — Optional or Accessory Electric Heater Control Connections

HUMIDI-MIZER® SYSTEM CONTROL CONNECTIONS

NOTE: It is suggested to ensure the Auto-Changeover function of an installed thermostat is enabled when used in conjunction with the Humidi-MiZer Adaptive Dehumidification system.

Humidi-MiZer System Space RH Controller

The Humidi-MiZer dehumidification system requires a field-supplied and field-installed space relative humidity control device. This device may be a separate humidistat control (contact closes on rise in space RH above control setpoint) or a combination thermostat-humidistat control device with isolated contact set for dehumidification control. See Fig. 63. The humidistat is normally used in applications where a temperature control is already provided (units with RTU Open control), or a ZS series sensor with humidity sensing. SystemVu™ controls require a Space Humidistat (HL38MG029), a Wall Mount Space Humidity Sensor (33ZCSENSRH-01), or a Duct Mount Humidity Sensor (33ZCSENDRH-01).

NOTE: 50LC14-26 units require a 3-stage cooling thermostat device and are not compatible with Carrier's Edge® Pro thermostat.

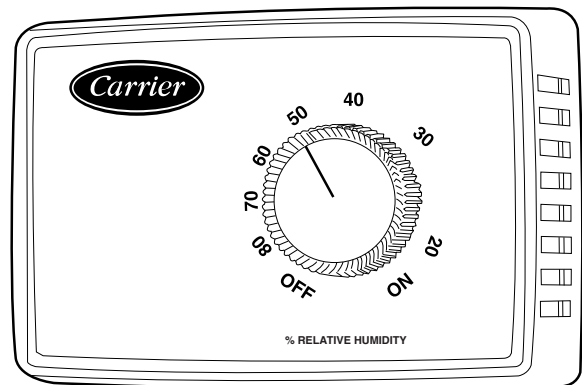

Fig. 63 — Accessory Field-Installed Humidistat

Connecting the Carrier Humidistat (HL38MG029)

1. Route the humidistat 2-conductor cable (field-supplied) through the hole provided in the unit corner post.
2. Feed wires through the raceway built into the corner post (see Fig. 58) to the 24v barrier located on the left side of the control box. The raceway provides the ETL-required clearance between high-voltage and low-voltage wiring.
3. Use wire nuts to connect humidistat cable to two PINK leads in the low-voltage wiring as shown in Fig. 64.

RTU Open Controller (Factory-Installed Option)

For details on operating 50LC*014-26 units equipped with the factory-installed RTU Open option refer to *48/50LC07-26 Factory Installed Option RTU Open Multi-Protocol Controller Controls, Start-up, Operation and Troubleshooting* manual.

SystemVu Controller (Factory-Installed Option)

For details on operating 50LC14-26 units equipped with the factory-installed SystemVu™ control option, refer to *48/50LC 07-26 Single Package Rooftop Units with SystemVu Controls Version 2.X Controls, Start-up, Operation and Troubleshooting* manual.

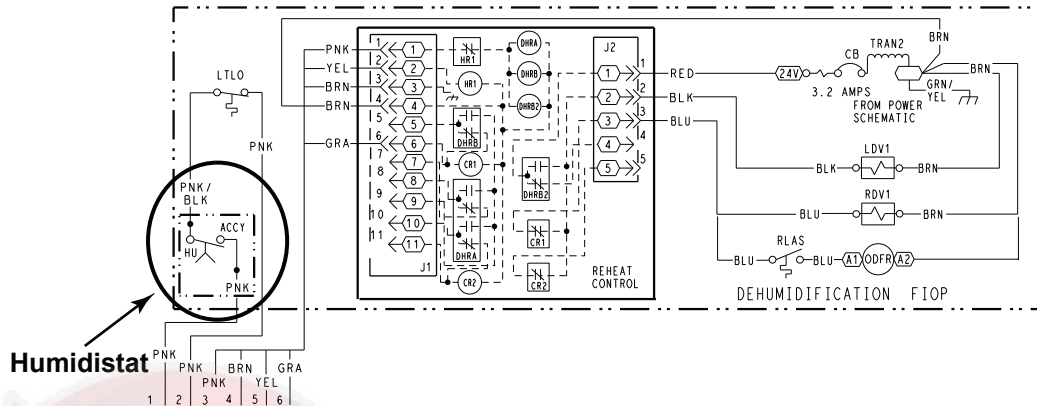

Fig. 64 — Typical Humidi-MiZer Adaptive Dehumidification System Humidistat Wiring



Integrated Staging Control (ISC)

SEQUENCE OF OPERATION

The Carrier Integrated Staging Control (ISC) is intended for use with a standard thermostat, direct digital controls (DDC) capable of three cooling stages, or the VAV-RTU Open controller (for LC*B units). After initial power to the board, a Green LED will blink with a 1 second duty cycle indicating the unit is running properly. In the event of the ISC board failing, the Green LED will be OFF or continuously ON. When the unit is not running properly, the Green LED will blink along with Red LED lights. The Red LED light configuration will indicate the type of error the board has identified. See Fig. 65 for LED locations and Table 3 for a list of status codes.

The ISC board can be remotely shutdown by removing Jumper 4 and wiring to the Remote Shutdown terminal. The Smoke Control Module can shutdown the unit by removing Jumper 3 and wiring to the Smoke Shutdown terminal. The Smoke Alarm terminal on the ISC Board provides a pass thru connection should a smoke alarm signal be connected. In the case of the RTU Open option, the RTU Open controller provides the signal which is passed through the ISC board to the Smoke Alarm terminal.

The crankcase heater will run at all times except when the compressors are running. An auxiliary power supply (24Vac) available at TB-4 Terminal is provided to power auxiliary equipment. An optional Phase Monitor Relay can be wired to the PMR terminal by removing Jumper 5. An optional Condensate Flow Switch can be wired to the COFS Terminal by removing Jumper 7.

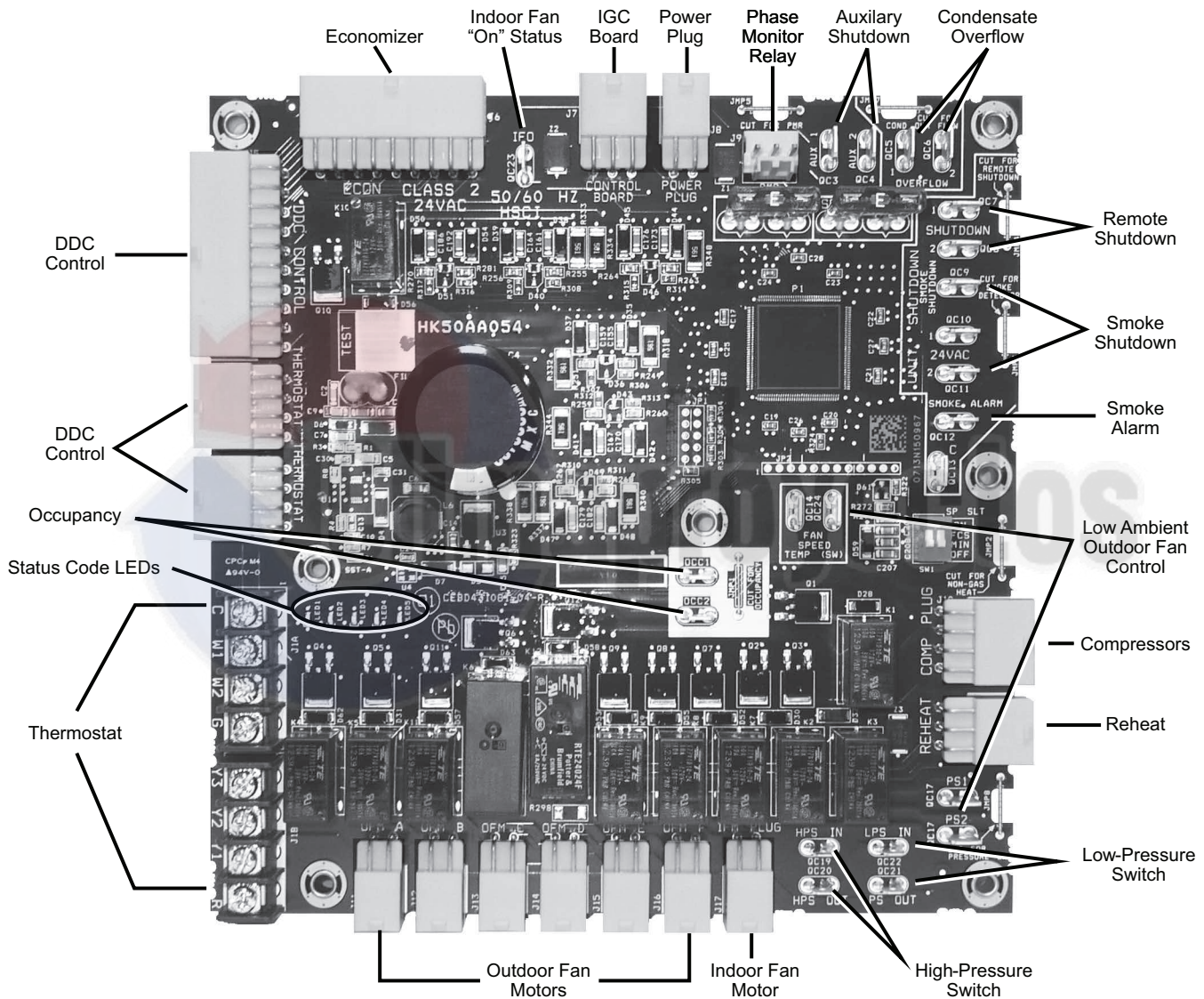

Fig. 65 — Integrated Staging Control (ISC) Board

Table 3 — ISC Board LEDs Status Code Descriptions

ERROR #	ERROR NAME	LED INDICATION					
		LED01	LED02	LED03	LED04	LED05	
1	Check Smoke Detector/PMR/AUX		RED	Blinking Green LED (Note 1)			
2	Check HPS/LPS/COFS	RED	RED				
3	Call for Y3 with no call for Y1. Check Y1 wiring.					RED	
4	Call for Y3 with no call for Y1/Y2. Check Y1 wiring.					RED	RED
5	Call for Y2 with no call for Y1. Check Y1 wiring.		RED			RED	
6	Call for W2 with no call for W1. Check W1 wiring.	RED					
7	Call for heat (W1/W2) and cooling (Y1/Y2/Y3). Check thermostat wiring.	RED	RED			RED	RED
8	Call for heat (W1/W2) with no G. Check G wiring.		RED			RED	RED
9	Call for cooling (Y1/Y2/Y3) with no G. Check G wiring.	RED	RED			RED	
10	Call for heat (W1/W2) and cooling (Y1/Y2/Y3) with no G. Check thermostat and G wiring.	RED	RED				RED
11	Check ISC Board and the thermostat wiring	RED				RED	RED
12	Check ISC Board and the thermostat wiring	RED					
13	Check ISC Board and the thermostat wiring	RED				RED	
14	Check ISC Board and the thermostat wiring						RED
15	Check ISC Board and the thermostat wiring		RED				RED

NOTES:

1. Green LED blinking at 1HZ indicates normal operation.
2. Solid red LED indicates an error exists; see above LED configuration.

Ventilation

In the Ventilation/Fan Mode (G), the indoor fan will run at low speed and the damper will operate at minimum position.

Cooling

In the Cooling Mode, the small and large compressors will be sequenced to maintain the thermostat temperature setpoint. Table 4 shows the cooling operation based on the indicated conditions.

The outdoor fan and VFD controlled indoor fan will operate at low, medium and high speed. The RPM is factory set by the CFM and static pressure requirements for the unit installed.

Table 4 — Cooling Mode Operation

INPUT	OUTPUT			
	Compressor		Indoor Fan Speed	Outdoor Fan Speed
Thermostat	C1	C2		
First Stage Cooling (Y1)	On	Off	Low	Low (700 RPM)
Second Stage Cooling (Y2)	Off	On	Medium	Medium (800 RPM)
Third Stage Cooling (Y2)	On	On	High	High (1000 RPM)

Humidi-MiZer® System (Optional)

In the Dehumidification Mode, both compressors will run and Indoor airflow will be rise to High Speed.

At subcooler reheating mode (reheat-1), during part load conditions when the room temperature and humidity are above the set point, the unit initiates the sub-cooling mode of operation; a call for cooling and dehumidification. RDV (Reheat Discharge Valve) and TWV (Three Way Valve) close; Indoor and Outdoor airflow will rise until reaching 100% of Speed.

At hot gas bypass reheating mode (reheat-2), when there is a call for dehumidification without a call for cooling, a portion of the hot gas from the compressor bypasses the condenser coil when RDV opens and hot gas is fed into the liquid line, TWV closes in this mode and the system provides mainly latent cooling. Indoor airflow will rise until reaching 100% of Speed, Outdoor airflow will run at High speed as long as outdoor temperature is above 80°F (26.7°C); when operating in this mode below 80°F (26.7°C) OAT, the system outdoor fan will operate as shown in Table 5 based on unit size.

Table 5 — Outdoor Fan Operation Below 80°F (26.7°C) OAT

50LC SIZE	RPM	NUMBER OF FANS ON	NUMBER OF FANS OFF
14	250	3	0
17	250	4	0
20	160	4	0
24	250	6	0
26	250	6	0

Economizer (Optional)

When the economizer is in Free Cooling Mode and a demand for cooling exists (Y1 on the thermostat), the economizer will modulate the outdoor-air damper to provide a 50°F (10°C) to 55°F (13°C) mixed-air temperature into the zone and run the indoor-fan at high speed. As mixed-air temperature fluctuates above 55°F (13°C) or below 50°F (10°C) dampers will be modulated (open or close) to bring the mixed-air temperature back within control. Upon more call for cooling (Y2 on the thermostat), the outdoor-air damper will maintain its current position, compressor C1 will run and the outdoor-fan will run at low speed. If there is further demand for cooling, the outdoor-air damper will maintain its current position, compressor C2 will run and the outdoor-fan will run at medium speed. The VFD controlled indoor-fan will operate at high speed regardless of the cooling demand.

If the increase in cooling capacity causes the mixed-air temperature to drop below 45°F (7°C), the outdoor-air damper will return to the minimum position. If the mixed-air temperature continues to fall, the outdoor-air damper will close. Control returns to normal once the mixed-air temperature rises above 48°F (9°C). The power exhaust fans will be energized and de-energized, if installed, as the outdoor-air damper opens and closes.

If field-installed accessory CO2 sensors are connected to the Economizer, a demand controlled ventilation strategy will begin to operate. As the CO2 level in the zone increases above the CO2 set-point, the minimum position of the damper will be increased proportionally. As the CO2 level decreases because of the increase of fresh air, the outdoor-air damper will be proportionally closed. For economizer operation, there must be a thermostat call for the fan (G). If the unit is occupied and the fan is on, the damper will operate at minimum position. Otherwise, the damper will be closed.

Low Ambient Cooling Operation Down to 40°F (4°C)

In Low Ambient RTU conditions when the temperature is between 55°F (13°C) and 40°F (4°C), the Low Ambient Switch (LAS) will be active and the outdoor fans will run to the pre-set factory outdoor-fan speed. When the temperature is greater than 65°F (18°C), the Low Ambient Switch will deactivate and the outdoor fans will run in the standard cooling mode. If the Outdoor Fan Select Switch (see Fig. 66) is in the ON position, the outdoor fans will run in the Fan Cycle Speed Mode (FCS) set to 250 rpm. If the Outdoor Fan Select Switch is in the OFF position, the outdoor fans will run in the Minimum Fan Speed Mode (MIN) set to 160 rpm regardless of the cooling demand.

The 50LC 14-26 units have a SPST normally open Low Ambient Switch wired across the TS and OF terminal and a jumper placed across the PS terminal (see Fig. 67). When the LAS is active, the switch will close making contact to the OF terminal. This is done for units that require all outdoor fans to run at the same pre-set factory Low Ambient Speed.

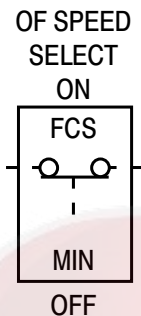

Fig. 66 — Outdoor Fan Speed Select Switch

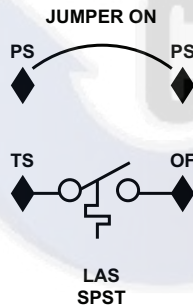

Fig. 67 — SPST Low Ambient Switch Schematic

Table 6 shows the low ambient temperature operation of the outdoor fan for each unit.

Table 6 — Low Ambient Temperature Outdoor Fan Control

50LC SIZE	NO. OF FANS ON	NO. OF FANS OFF	SWITCH	OUTDOOR FAN SELECT SWITCH	RPM
14	3	0	SPST	Up	250
17	4	0	SPST	Up	250
20	4	0	SPST	Up	250
24	6	0	SPST	Up	250
26	6	0	SPST	Up	250

Heating

In the Heating Mode (W1 on the thermostat), power is applied to the G and W1 terminal at the ISC board and energizes the first state of electric heat. Upon more call for heat (W2 at the thermostat), power is applied to the G and W2 terminal at the ISC board and energizes the second state of electric heat. The VFD

controlled indoor fan will operate at high speed regardless of the heating demand.

EconoMi\$er® X (Factory-Installed Option)

EconoMi\$er X is an economizer system available for 50LC 14-26 units. The factory-installed option consists of:

- Either a ultra low leak or a low leak economizer damper assembly
- Direct-drive damper actuator with local equipment bus communications
- W7220 economizer controller with keypad and display
- Supply air temperature sensor (20k ohm)
- Outdoor changeover condition sensor (either 20k ohm dry bulb or enthalpy sensor)

UNIT INSTALLATION

All damper hardware and standard economizer control components except the enthalpy sensor are factory-mounted in their operating location. Complete the unit installation by relocating the enthalpy sensor (when provided; see below), then assembling and mounting the unit's outside air hood. Refer to the base unit's installation instruction manual for directions on locating the hood parts package and assembling the hood with filters.

ENTHALPY SENSOR RELOCATION

See the section Enthalpy Control Sensor Configuration on page 57 for a view of the enthalpy sensor and DIP switch settings. Locate the enthalpy sensor on the side of the economizer housing; remove mounting screws and save screws. Confirm the DIP switches are set at OFF, OFF, OFF. Move the enthalpy sensor to the front face of the economizer housing and mount per label.

W7220 ECONOMIZER CONTROLLER

The Honeywell W7220 economizer controller is used on electro-mechanical units. The W7220 provides typical economizer functions, including:

- Management of outside air damper for base unit Occupied (damper open and modulating) and unit OFF or Unoccupied status (damper closed)
- Free-cooling using all outside air when outdoor conditions permit Integrated cooling operation using outside air and mechanical cooling when required
- Demand Controlled Ventilation (DCV) for modulating ventilation airflow according to space CO₂ level (requires factory-option or field-installed CO₂ sensor)

The W7220 control can also adjust the damper control points during DCV or minimum ventilation operation as the indoor fan speed is changed. This control function ensures that required space ventilation airflow quantities are maintained during reduced fan speed operation.

Additional control capabilities include automatic detection of new sensors and detection of sensor failure or loss of communication.

The W7220 control module includes an integral user interface with keypad and LCD display that permits direct input of setpoint values and configurations, and displays status and alarms.

The W7220 controller is located in the RTU base unit's Control Box. See the Installation Instructions for this base unit for the location of the Control Box access panel.

User Interface

The user interface consists of a 2-line LCD display and a 4-button keypad on the front of the economizer controller.

Keypad

Use the four navigation buttons (see Fig. 68) to scroll through the menus and menu items, select menu items, and to change parameter and configuration settings.

To use the keypad when working with menus:

- Press the ▲ (Up arrow) button to move to the previous menu.
- Press the ▼ (Down arrow) button to move to the next menu.
- Press the ↵ (Enter) button to display the first item in the currently displayed menu.
- Press the ⏪ (Menu Up/Exit) button to exit a menu's item and return to the list of menus.

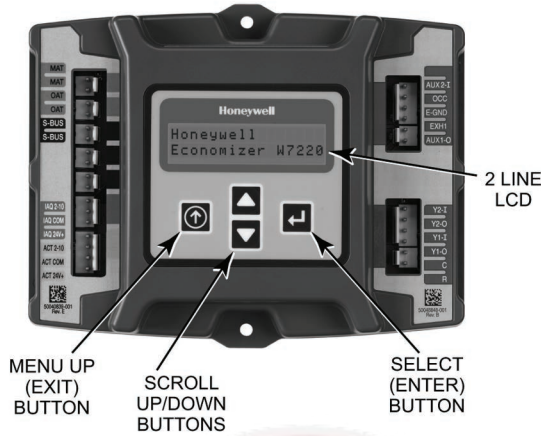

Fig. 68 — W7220 Controller Navigation Buttons

The Menus in display order are:

- STATUS
- SETPOINTS
- SYSTEM SETUP
- ADVANCED SETUP
- CHECKOUT
- ALARMS

To use the keypad when working with Setpoints, System and Advanced Settings, Checkout tests and Alarms:

1. Navigate to the desired menu.
2. Press the ↵ (Enter) button to display the first item in the currently displayed menu.
3. Use the ▲ and ▼ buttons to scroll to the desired parameter.
4. Press the ↵ (Enter) button to display the value of the currently displayed item.
5. Press the ▲ button to increase (change) the displayed parameter value.
6. Press the ▼ button to decrease (change) the displayed parameter value.

NOTE: When values are displayed, pressing and holding the ▲ or ▼ button causes the display to automatically increment or decrement.

1. Press the ↵ (Enter) button to accept the displayed value and store it in nonvolatile RAM. "CHANGE STORED" displays.
2. Press the ↵ (Enter) button to return to the current menu parameter.
3. Press the ⏪ (Menu Up/Exit) button to return to the previous menu.

Menu Structure

Table 7 illustrates the complete hierarchy of menus and parameters for the EconoMiSer® X system.

IMPORTANT: Table 7 illustrates the complete hierarchy. Your menu parameters may be different depending on your configuration.

For example, if you do not have a DCV (CO₂) sensor, then none of the DCV parameters appear and only MIN POS will display. If you have a CO₂ sensor, the DCV MIN and DCV MAX will appear.

The menu hierarchy has been modified to reflect controller configuration for 2-speed indoor fan application in the Staged Air Volume option.

NOTE: Some parameters in the menus use the letters MA or MAT, indicating a mixed air temperature sensor location before the cooling coil. This unit application has the control sensor located after the cooling coil, in the fan section, where it is designated as (Cooling) Supply Air Temperature or SAT sensor.

Table 7 — W7220 Menu Structure*

MENU	PARAMETER	PARAMETER DEFAULT VALUE	PARAMETER RANGE AND INCREMENT†	EXPANDED PARAMETER NAME/NOTES
STATUS	ECON AVAIL	NO	YES/NO	ECONOMIZING AVAILABLE YES = economizing available; the system can use outside air for free cooling when required
	ECONOMIZING	NO	YES/NO	ECONOMIZING ACTIVE YES = outside air being used for 1 stage cooling NO = economizing not active
	OCCUPIED	NO	YES/NO	OCCUPIED YES = OCC signal received from space thermostat or unitary controller YES = 24 Vac on terminal OCC NO = 0 Vac on terminal OCC
	HEAT PUMP	N/A**	COOL HEAT	HEAT PUMP MODE (Not available on 2-speed configuration)
	COOL Y1—IN	OFF	ON/OFF	FIRST STAGE COOLING DEMAND (Y1-IN) Y1-I signal from space thermostat or unitary controller for cooling stage 1. ON = 24 Vac on terminal Y1-I OFF = 0 Vac on terminal Y1-I
	COOL Y1—OUT	OFF	ON/OFF	FIRST STAGE COOLING RELAY OUTPUT ON = 24 Vac on terminal Y1-O; Stage 1 mechanical cooling called on OFF = 0 Vac on terminal Y1-O; no mechanical cooling
	COOL Y2—IN	OFF	ON/OFF	SECOND STAGE COOLING DEMAND (Y2—IN) Y2-I signal from space thermostat or unitary controller for cooling stage 2. ON = 24 Vac on terminal Y2-I OFF = 0 Vac on terminal Y2-I
	COOL Y2—OUT	OFF	ON/OFF	SECOND STAGE COOLING RELAY OUTPUT ON = 24 Vac on terminal Y2-O; Stage 2 mechanical cooling called on OFF = 0 Vac on terminal Y2-O; no Stage 2 mechanical cooling
	MA TEMP	nn°F (or °C)	0 to 140°F (-18 to 60°C)	SUPPLY AIR TEMPERATURE, Cooling Mode Displays value of measured mixed air from SAT sensor in fan section. Displays _ . _ if not connected, short or out-of-range. See Note 2.
	DA TEMP	nn°F (or °C)	0 to 140°F (-18 to 60°C)	DISCHARGE AIR TEMPERATURE, after Heating section (Accessory sensor required) Displays when Discharge Air sensor is connected and displays measured discharge temperature. Displays _ . _ if sensor sends invalid value, if not connected, short or out-of-range.
	OA TEMP	nn°F (or °C)	-40 to 140°F (-40 to 60°C)	OUTSIDE AIR TEMP Displays measured value of outdoor air temperature. Displays _ . _ if sensor sends invalid value, short or out-of-range.
	OA HUM	nn%	0 to 100%	OUTSIDE AIR RELATIVE HUMIDITY Displays measured value of outdoor humidity from OA enthalpy sensor.
	RA TEMP	nn°F (or °C)	0 to 140°F (-18 to 60°C)	RETURN AIR TEMPERATURE (Accessory sensor required) Displays measured value of return air temperature from RAT sensor.
	RA HUM	nn%	0 to 100%	RETURN AIR RELATIVE HUMIDITY (Accessory enthalpy sensor required) Displays measured value of return air humidity from RA sensor.
	IN CO2	— — — ppm	0 TO 2000 ppm	SPACE/RETURN AIR CO ₂ (CO ₂ sensor required, accessory or factory option) Displays value of measured CO ₂ from CO ₂ sensor. Invalid if not connected, short or out-of-range
	DCV STATUS	N/A	ON/OFF	DEMAND CONTROLLED VENTILATION STATUS (CO ₂ sensor required, accessory or factory option) Displays ON if IN CO ₂ value above setpoint DCV SET and OFF if below setpoint DCV SET.
	DAMPER OUT	2.0V	2.0 TO 10.0v	Displays voltage output to the damper actuator. 2.0V = OSA damper fully closed 10.0V = OSA damper fully open
	ACT POS	nn%	0 to 100%	Displays actual position of outdoor air damper actuator 0% = OSA damper fully closed 100% = OSA damper fully open

Table 7 — W7220 Menu Structure* (cont)

MENU	PARAMETER	PARAMETER DEFAULT VALUE	PARAMETER RANGE AND INCREMENT†	NOTES
STATUS (cont)	ACT COUNT	N/A	1 to 65535	Displays number of times actuator has cycled. 1 cycles equals accrued 180 deg. of actuator movement in any direction.
	ACTUATOR	N/A	OK/Alarm (on Alarm menu)	Displays ERROR if voltage or torque is below actuator range.
	EXH1 OUT	OFF	ON/OFF	EXHAUST STAGE 1 RELAY OUTPUT Output of EXH1 terminal: ON = relay closed OFF = relay open
	EXH2 OUT	OFF	ON/OFF	EXHAUST STAGE 2 RELAY OUTPUT Output of AUX terminal; displays only if AUX = EXH2 ON = relay closed OFF = relay open
	MECH COOL ON	0	0, 1, or 2	Displays stage of mechanical cooling that is active.
	FAN SPEED	N/A	LOW or HIGH	SUPPLY FAN SPEED Displays speed setting of fan on a 2-speed fan unit.
	W (HEAT ON)	N/A	ON/OFF	HEAT DEMAND STATUS Displays status of heat demand on a 2-speed fan unit.
SETPOINTS	MAT SET	53°F (12°C)	38 to 65°F (3 to 18°C); increment by 1	SUPPLY AIR SETPOINT Setpoint determines where the economizer will modulate the OA damper to maintain the mixed air temperature. See Note 2.
	LOW T LOCK	32°F (0°C)	-45 to 80°F (-43 to 27°C); increment by 1	COMPRESSOR LOW TEMPERATURE LOCKOUT Setpoint determines outdoor temperature when the mechanical cooling cannot be turned on.
	DRYBLB SET	63°F (17°C)	48 to 80°F (9 to 27°C); increment by 1	OA DRY BULB TEMPERATURE CHANGEOVER SETPOINT Setpoint determines where the economizer will assume outdoor air temperature is good for free cooling; e.g., at 63°F (17°C) unit will economize at 62°F (16.7°C) and below and not economize at 64°F (17.8°C) and above. There is a 2°F (1.1°C) deadband. See Note 3.
	ENTH CURVE	ES3	ES1,ES2,ES3,ES4, or ES5	ENTHALPY CHANGEOVER CURVE (Requires enthalpy sensor option) Enthalpy boundary "curves" for economizing using single enthalpy.
	DCV SET	1100ppm	500 to 2000ppm; increment by 100	DEMAND CONTROLLED VENTILATION Displays only if CO ₂ sensor is connected. Setpoint for Demand Control Ventilation of space. Above the setpoint, the OA dampers will modulate open to bring in additional OA to maintain a space ppm level below the setpoint.
	MIN POS L	6.0 V	2 to 10 Vdc	VENTILATION MINIMUM POSITION AT LOW SPEED Displays ONLY if a CO ₂ sensor is NOT connected.
	MIN POS H	4.4 V	2 to 10 Vdc	VENTILATION MINIMUM POSITION AT HIGH SPEED Displays ONLY if a CO ₂ sensor is NOT connected.
	VENTMAX L	6.0 V	2 to 10 Vdc	DCV MAXIMUM DAMPER POSITION AT LOW SPEED Requires CO ₂ sensor connected.
	VENT MAX H	4.4 V	2 to 10 Vdc	DCV MAXIMUM DAMPER POSITION AT HIGH SPEED Requires CO ₂ sensor connected.
	VENTMIN L	3.7 V	2 to 10 Vdc	DCV MINIMUM DAMPER POSITION AT LOW SPEED Requires CO ₂ sensor connected.
	VENTMINH	2.8 V	2 to 10 Vdc	DCV MINIMUM DAMPER POSITION AT HIGH SPEED Requires CO ₂ sensor connected.
	EXH1 L SET	65%	0 to 100%; increment by 1	EXHAUST FAN STAGE 1 SETPOINT AT LOW SPEED Setpoint for OA damper position when exhaust fan 1 is powered by the economizer.
	EXH1 H SET	50%	0 to 100%; increment by 1	EXHAUST FAN STAGE 1 SETPOINT AT HIGH SPEED Setpoint for OA damper position when exhaust fan 1 is powered by the economizer.
	EXH2 L SET	80%	0 to 100%; increment by 1	EXHAUST FAN STAGE 2 SETPOINT AT LOW SPEED Setpoint for OA damper position when exhaust fan 1 is powered by the economizer. Only used when AUX1-O is set to EHX2.
EXH2 H SET	75%	0 to 100%; increment by 1	EXHAUST FAN STAGE 2 SETPOINT AT HIGH SPEED Setpoint for OA damper position when exhaust fan 1 is powered by the economizer. Only used when AUX1-O is set to EHX2.	

Table 7 — W7220 Menu Structure* (cont)

MENU	PARAMETER	PARAMETER DEFAULT VALUE	PARAMETER RANGE AND INCREMENT†	NOTES
SYSTEM SETUP	INSTALL	01/01/10	N/A	Display order = MM/DD/YY Setting order = DD, MM, then YY
	UNITS DEG	°F	°F or °C	Sets economizer controller in degrees Fahrenheit or Celsius
	EQUIPMENT	CONV	Conventional or HP	CONV = conventional; HP O/B = Enable Heat Pump mode. Not available with 2-speed. See Note 4.
	AUX2 I	W	W required for 2-speed mode	W = Informs controller that system is in heating mode. SD = Enables configuration of shutdown (not available on 2-speed). See Note 4.
	FAN TYPE	2 speed	2 speed required	Sets the economizer controller for operation of 1 speed or 2 speed indoor fan system. See Note 4.
	FAN CFM	5000cfm	100 to 15000 cfm; increment by 100	UNIT DESIGN AIRFLOW (CFM) Enter only if using DCVAL ENA = AUTO The value is found Project Submittal documents for the specific unit.
	AUX OUT	NONE	NONE EXH2 SYS	Select OUTPUT for AUX1 O relay • NONE = not configured (output is not used) • EXH2 = second damper position relay closure for second exhaust fan • SYS = use output as an alarm signal
	OCC	INPUT	INPUT or ALWAYS	OCCUPIED MODE BY EXTERNAL SIGNAL When using a setback thermostat with occupancy out (24 vac), the 24 vac is input to the OCC terminal. RTU control circuit provides 24-Vac to OCC through OCCUPIED terminals on Integrated Staging Control Board.
	FACTORY DEFAULT	NO	NO or YES	Resets all set points to factory defaults when set to YES. LCD will briefly flash YES and change to NO but all parameters will change to the factory default values. NOTE: RECHECK AUX2 IN and FANTYPE for required 2-speed values.
ADVANCED SETUP	MA LO SET	45°F (7°C)	35 to 55°F (2 to 12°C); Incremented by 1°	SUPPLY AIR TEMPERATURE LOW LIMIT Temperature to achieve Freeze Protection (close damper and alarm if temperature falls below setup value).
	FREEZE POS	CLO	CLO or MIN	FREEZE PROTECTION DAMPER POSITION Damper position when freeze protection is active. CLO = closed MIN = MIN POS or VENT MAX
	CO2 ZERO	0ppm	0 to 500 ppm; Increment by 10	CO ₂ ppm level to match CO ₂ sensor start level.
	CO2 SPAN	2000ppm	1000 to 3000 ppm; Increment by 50	CO ₂ ppm span to match CO ₂ sensor.
	STG3 DLY	2.0h	0 min, 5 min, 15 min, then 15 min intervals. Up to 4 hrs or OFF	COOLING STAGE 3 DELAY Delay after stage 2 cool has been active. Turns on second stage of cooling when economizer is first stage and mechanical cooling is second stage.
	SD DMPR POS	CLO	CLO or OPN	Function not available with 2-speed mode.
	DCVCAL ENA	MAN	MAN (manual)	Turns on the DCV automatic control of the dampers. Resets ventilation.
	MAT T CAL	0.0°F (or C)	±2.5°F (±1.4°C)	SUPPLY AIR TEMPERATURE CALIBRATION Allows for the operator to adjust for an out of calibration supply air temperature (SAT) sensor.
	OA T CAL	1.0°F (or C)	±2.5°F (±1.4°C)	OUTSIDE AIR TEMPERATURE CALIBRATION Allows for the operator to adjust for an out of calibration outside air temperature (OAT) sensor.
	OA H CAL	0% RH	±10% RH	OUTSIDE AIR HUMIDITY CALIBRATION Allows for operator to adjust for an out of calibration enthalpy sensor.
	RA T CAL	2.0°F (or C)	±2.5°F (±1.4°C)	RETURN AIR TEMPERATURE CALIBRATION Allows for the operator to adjust for an out of calibration return air temperature (RAT) sensor.
	RA H CAL	0% RH	±10% RH	RETURN AIR HUMIDITY CALIBRATION Allows for operator to adjust for an out of calibration return air enthalpy sensor.
	DA T CAL	0.0°F (or C)	±2.5°F (±1.4°C)	DISCHARGE AIR TEMPERATURE CALIBRATION Allows for the operator to adjust for an out of calibration discharge air (DAT) temperature sensor.
	2SP FAN DELAY	5 Minutes	0 to 20 minutes in 1 minute increments	TIME DELAY ON 2nd STAGE ECONOMIZING When in economizing mode, this is the delay between thermostat Y2 call and Y1-O output to mechanical cooling stage, to allow high speed fan operation to attempt to cool space first.

Table 7 — W7220 Menu Structure* (cont)

MENU	PARAMETER	PARAMETER DEFAULT VALUE	PARAMETER RANGE AND INCREMENT†	NOTES
CHECKOUT	DAMPER VMIN .HS	N/A	N/A	Positions OA damper to VMIN High Speed position.
	DAMPER VMAX .HS	N/A	N/A	Positions OA damper to VMAX High Speed position.
	DAMPER OPEN	N/A	N/A	Position damper to the full open position.
	DAMPER CLOSE	N/A	N/A	Positions damper to the fully closed position
	CONNECT Y1-O	N/A	N/A	Closes the Y1-O relay (Y1-O)
	CONNECT Y2-O	N/A	N/A	Closes the Y2-O relay (Y2-O)
	CONNECT AUX1O	N/A	N/A	Energizes the AUX1O output. If Aux setting is: • NONE — not action taken • ERV — 24 Vac out. Turns on or signals an ERV that the conditions are not good for economizing but are for ERV operation.†† • SYS — 24 Vac out. Issues a system alarm.
	CONNECT EXH1	N/A	N/A	Closes the power exhaust fan 2 relay (EXH1)
ALARMS	Alarms display only when they are active. The menu title "ALARMS(#)" includes the number of active alarms in parenthesis ().			
	MA T SENS ERR	N/A	N/A	SUPPLY AIR TEMPERATURE SENSOR ERROR Mixed air sensor has failed or become disconnected - check wiring then replace sensor if the alarm continues.
	CO2 SENS ERR	N/A	N/A	CO ₂ SENSOR ERROR CO ₂ sensor has failed, gone out of range or become disconnected - check wiring then replace sensor if the alarm continues.
	OA T SENS ERR	N/A	N/A	OUTSIDE AIR TEMPERATURE SENSOR ERROR OAT sensor connected at input terminals OAT. Outdoor air temperature sensor has failed or become disconnected - check wiring then replace if the alarm continues.
	OA SYLK SENS ERR	N/A	N/A	OUTSIDE AIR TEMPERATURE SENSOR ERROR OAT sensor connected on S-bus.
	RA SYLK T ERR	N/A	N/A	RETURN AIR S-BUS SENSOR ERROR
	RA SYLK H ERR	N/A	N/A	Return air enthalpy sensor has failed or become disconnected - check wiring then replace sensor if the alarm continues.
	DA T SENS ERR	N/A	N/A	DISCHARGE AIR TEMPERATURE SENSOR ERROR Discharge air temperature is out of the range set in the ADVANCED SETUP Menu. Check the temperature of the discharge air.
	SYS ALARM	N/A	N/A	When AUX is set to SYS and there is any alarm (e.g., failed sensors, etc.), the AUX terminal has 24 Vac out.
	ACT UNDER V	N/A	N/A	ACTUATOR VOLTAGE LOW Voltage received by actuator is below expected range.
	ACT OVER V	N/A	N/A	ACTUATOR VOLTAGE HIGH Voltage received by actuator is above expected range.
	ACT STALLED	N/A	N/A	ACTUATOR STALLED Actuator stopped before reaching commanded position.

LEGEND

- ACT** — ACTUATOR
- CLO** — COMPRESSOR LOCKOUT
- DA** — DISCHARGE AIR
- ERV** — ENERGY RECOVERY VENTILATOR
- LCD** — LIQUID CRYSTAL DISPLAY
- MA** — MIXED AIR
- MAT** — MIXED AIR TEMPERATURE
- N/A** — NOT APPLICABLE
- OA** — OUTDOOR AIR
- OAT** — OUTDOOR AIR TEMPERATURE
- OCC** — OCCUPIED
- RA** — RETURN AIR
- RAT** — RETURN AIR TEMPERATURE
- RTU** — ROOFTOP UNIT
- SYS** — SYSTEM

* Table 7 illustrates the complete hierarchy. Your menu parameters may be different depending on your configuration. For example if you do not have a DCV (CO₂) sensor, then none of the DCV parameters appear.

† When values are displayed, pressing and holding the ▲ or ▼ button causes the display to automatically increment.

** N/A = Not Applicable.

†† ERV Operation: When in Cooling mode AND the conditions are NOT OK for economizing, the ERV terminal will be energized. In the Heating mode the ERV terminal will be energized when the OA is below the ERV OAT setpoint in the setpoint menu.

NOTES:

1. STATUS → OCCUPIED — The factory-standard Occupancy signal originates with a thermostat or other controller call for indoor operation at ISC terminal G. This signal passes through the Integrated Staging Control Board's OCCUPIED jumper JMP1 to the ECONO connector and to the W7220's OCC input terminal. An external timeclock or relay is required to implement an Occupancy schedule on the economizer damper position.
2. STATUS → MA TEMP, SETPOINTS → MAT SET — The W7220 menu parameters and labels include designations MA , MAT and Mixed Air for the economizer cooling control sensor. On these rooftop units, the economizer control sensor is located downstream of the evaporator/indoor coil in the supply fan section where this sensor is designated as Supply Air Temperature (SAT) sensor.
3. SETPOINTS → DRYBLB SET — This point is not displayed if a Return Air (differential) temperature sensor or an Outdoor Air enthalpy sensor is connected.
4. SYSTEM SETUP parameters must be configured as noted for 2-Speed unit operation:
 EQUIPMENT = CONV
 AUX2 I = W
 FAN TYPE = 2SPEED

W7220 ECONOMIZER MODULE WIRING

Use Fig. 69 and Tables 8 and 9 to locate the wiring terminals for the Economizer module. See Fig. 70 and 71 for sensor and controls connections.

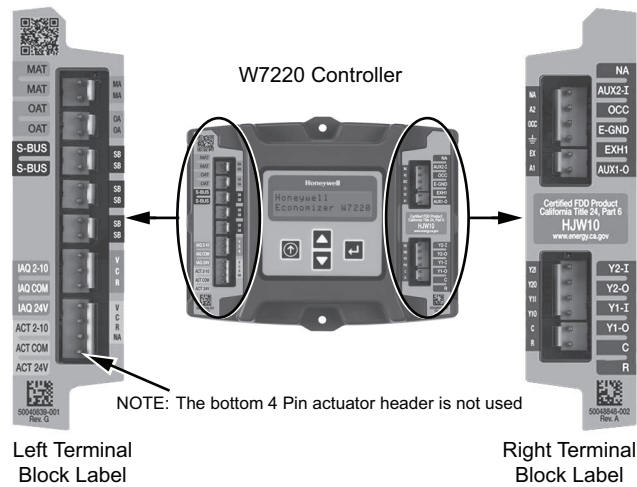

Fig. 69 — W7220 Wiring Terminals

Table 8 — Economizer Module - Left Hand Terminal Blocks

LABEL	TYPE	DESCRIPTION
TOP LEFT TERMINAL BLOCK		
MAT MAT	20K NTC AND COM	MIXED AIR TEMPERATURE SENSOR (POLARITY INSENSITIVE CONNECTION)
OAT OAT	20K NTC AND COM	OUTDOOR AIR TEMPERATURE SENSOR (POLARITY INSENSITIVE CONNECTION)
S-BUS S-BUS	S-BUS (SYLK* BUS)	ENTHALPY CONTROL SENSOR (POLARITY INSENSITIVE CONNECTION)
BOTTOM LEFT TERMINAL BLOCK		
IAQ 2-10	2-10 VDC	AIR QUALITY SENSOR INPUT (E.G. CO ₂ SENSOR)
IAQ COM	COM	AIR QUALITY SENSOR COMMON
IAQ 24V	24 VAC	AIR QUALITY SENSOR 24 VAC SOURCE
ACT 2-10	2-10 VDC	DAMPER ACTUATOR OUTPUT (2-10 VDC)
ACT COM	COM	DAMPER ACTUATOR OUTPUT COMMON
ACT 24V	24 VAC	DAMPER ACTUATOR 24 VAC SOURCE

* Sylk is a trademark of Honeywell International Inc.

Table 9 — Economizer Module - Right Hand Terminal Blocks

LABEL	TYPE	DESCRIPTION
TOP RIGHT TERMINAL BLOCKS		
AUX2-I	24 VAC IN	THE FIRST TERMINAL IS NOT USED.
OCC	24 VAC IN	SHUT DOWN (SD) OR HEAT (W) CONVENTIONAL ONLY AND HEAT PUMP CHANGEOVER (O-B) IN HEAT PUMP MODE.
E-GND	E-GND	OCCUPIED/UNOCCUPIED INPUT
EXH1	24 VAC OUT	EXHAUST FAN 1 OUTPUT
AUX1-O	24 VAC OUT	PROGRAMMABLE: EXHAUST FAN 2 OUTPUT OR ERV OR SYSTEM ALARM OUTPUT
BOTTOM RIGHT TERMINAL BLOCKS		
Y2-I	24 VAC IN	Y2 IN - COOLING STAGE 2 INPUT FROM SPACE THERMOSTAT
Y2-O	24 VAC OUT	Y2 OUT - COOLING STAGE 2 OUTPUT TO STAGE 2 MECHANICAL COOLING
Y1-I	24 VAC IN	Y1 IN - COOLING STAGE 2 INPUT FROM SPACE THERMOSTAT
Y1-O	24 VAC OUT	Y1 OUT - COOLING STAGE 2 OUTPUT TO STAGE 2 MECHANICAL COOLING
C	COM	24 VAC COMMON
R	24 VAC	24 VAC POWER (HOT)

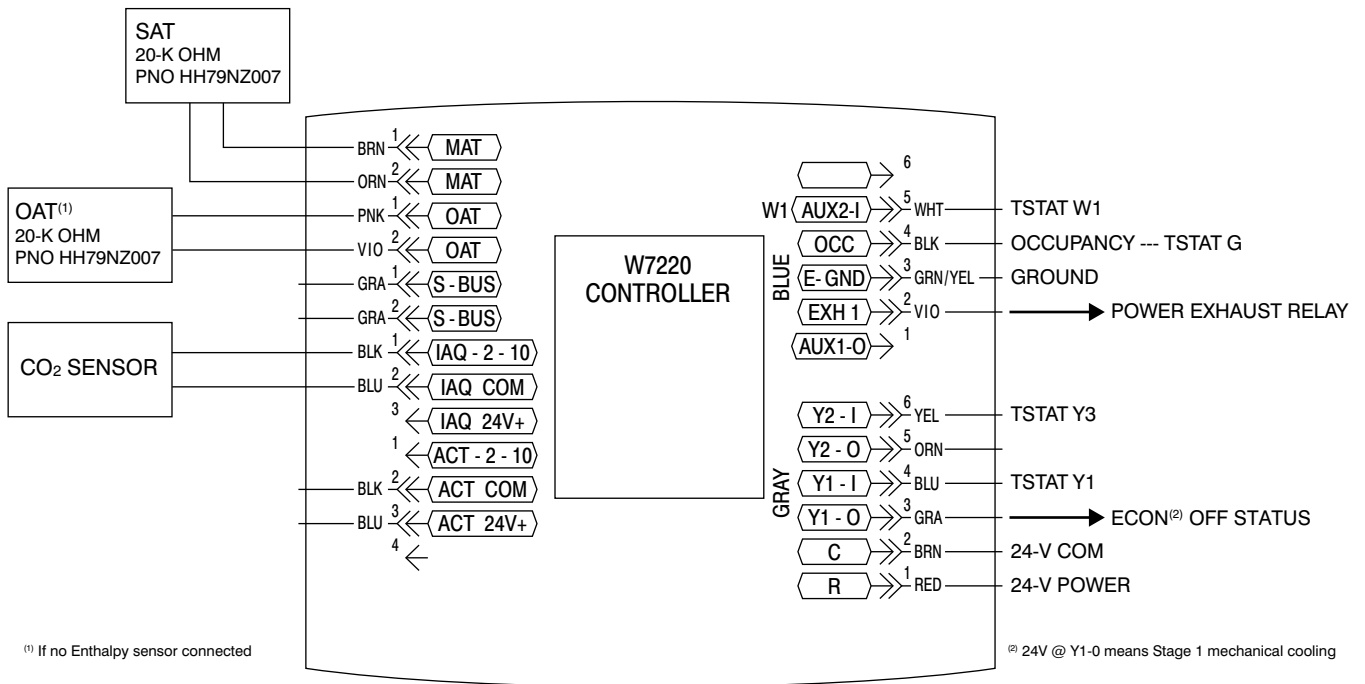

Fig. 70 — W7220 Sensor and Control I/O Connections

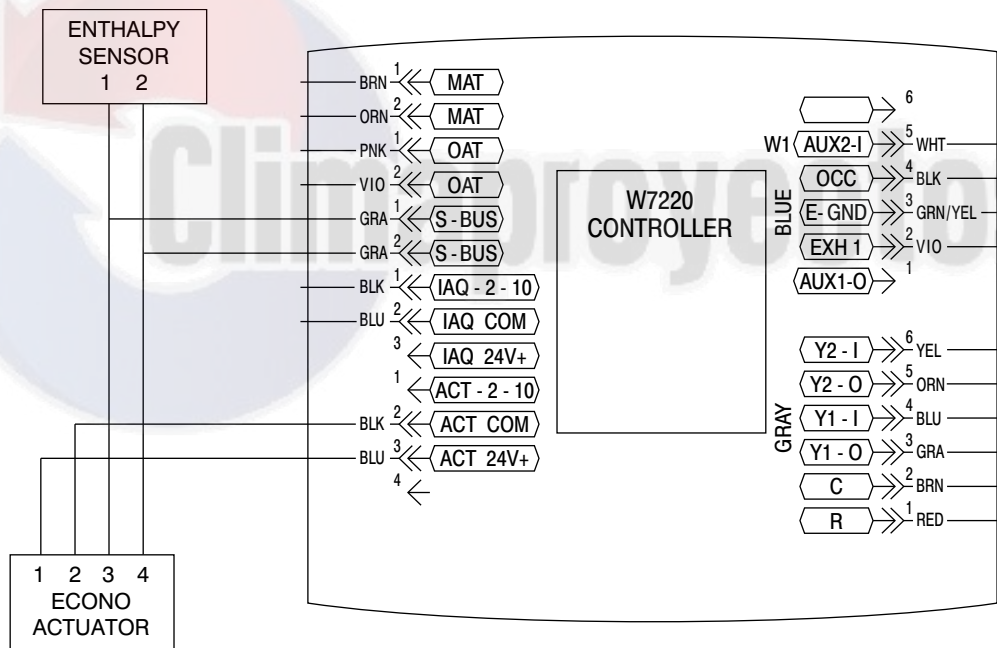

Fig. 71 — Actuator/S-Bus

ECONOMIZER CONTROL CONFIGURATIONS

Enthalpy Changeover Control

Economizer changeover based on outdoor air enthalpy requires an outdoor air enthalpy sensor to replace the OAT sensor. The enthalpy sensor is available as a factory-installed option or as a field-installed accessory (P/N HH57AC081). See Fig. 1 for model number nomenclature; check Position #15 for codes R or S indicating a factory-installed enthalpy sensor. Use Fig. 72 and Table 10 to select the enthalpy changeover setting to enter in menu item SETPOINTS -> ENTH CURVE.

Enthalpy Settings

When the OA temperature, enthalpy and dew point are below the respective setpoints, the Outdoor Air can be used for economizing. Fig. 72 shows the single enthalpy boundaries in the W7220. There are 5 boundaries (setpoints ES1 through ES5), which are defined by dry bulb temperature, enthalpy and dew point.

Refer to Table 10 for ENTH CURVE setpoint values.

The W7220 calculates the enthalpy and dew point using the OA temperature and humidity input from the OA enthalpy sensor. When the OA temperature, OA humidity and OA dew point are all below the selected boundary, the economizer sets the economizing mode to YES, economizing is available.

When all of the OA conditions are above the selected boundary, the conditions are not good to economize and the mode is set to NO.

Figure 72 shows the 5 current boundaries. There is also a high limit boundary for differential enthalpy. The high limit boundary is ES1 when there are no stages of mechanical cooling energized and HL (high limit) when a compressor stage is energized.

Table 10 provides the values for each boundary limit.

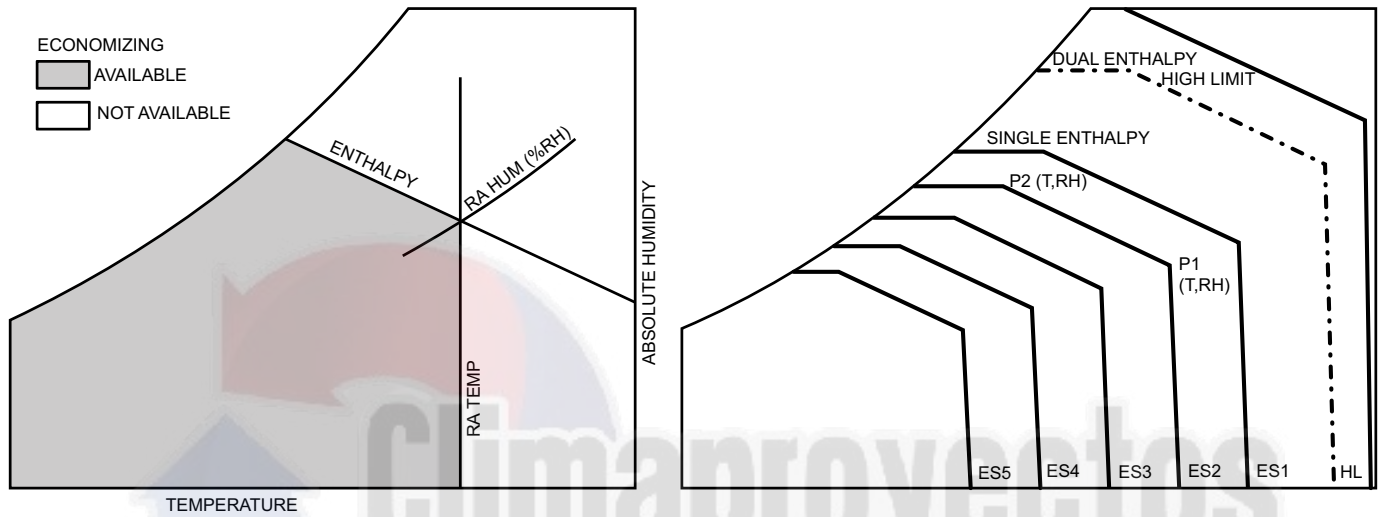

Fig. 72 — Single Enthalpy Curve Boundaries

Table 10 — Single Enthalpy and Dual Enthalpy High Limit Curves

ENTHALPY CURVE	TEMP. DRY BULB (F)	TEMP. DEWPOINT (F)	ENTHALPY (BTU/LB/DA)	POINT P1		POINT P2	
				TEMP. (F)	HUMIDITY (%RH)	TEMP. (F)	HUMIDITY (%RH)
ES1	80	60	28.0	80	36.8	66.3	80.1
ES2	75	57	26.0	75	39.6	63.3	80.0
ES3	70	54	24.0	70	42.3	59.7	81.4
ES4	65	51	22.0	65	44.8	55.7	84.2
ES5	60	48	20.0	60	46.9	51.3	88.5
HL	86	66	32.4	86	38.9	72.4	80.3

Demand Controlled Ventilation (DCV)

Demand Controlled Ventilation (DCV) function requires a space air CO₂ sensor be connected to the W7220 controller. The CO₂ sensor provides a 2 to 10 vdc signal proportional to the space CO₂ level. This sensor is available as a factory-installed option (located in the unit's return air plenum) or as a field-installed accessory. See Fig. 1 for model number nomenclature; check Position #9 for codes E, F, G or H indicating a factory-installed CO₂ sensor. The W7220 automatically recognizes the connection of this sensor and self-enables the DCV function after the Configuration period.

DCV with Single-Speed Fan System

During DCV, the outside air damper modulates between two user configurations depending upon the signal level of the space or return air CO₂ sensor representing the space occupancy level. The lower of these two positions is referred to as the Minimum IAQ Damper Position (designated VENTMIN) while the higher is referred to as Economizer Minimum Position (designated MINIMUM POSITION or VENTMAX). The VENTMIN position should be set to an economizer position that brings in enough fresh air to remove contaminants and CO₂ generated by sources other than people; this airflow rate is designated Va. The VENTMAX should be set to an economizer position that brings in enough fresh air to remove contaminants and CO₂ generated by all sources including people at the design condition for maximum space occupancy; this airflow rate is designated Vbz. See Fig. 73.

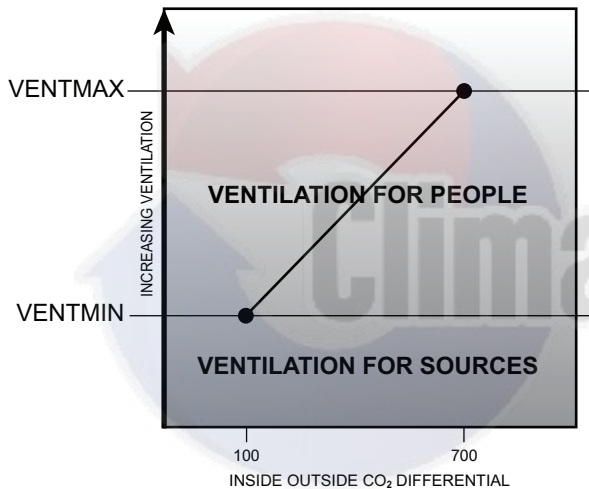

Fig. 73 — DCV Single-Speed System Setpoints

DCV with Two-Speed Fan System

Ventilation codes require that the same ventilation rates (Vbz and Va, expressed as CFM) be provided regardless of supply fan speed. When the supply fan speed is reduced, the internal static pressure in the unit's return plenum also decreases. If the same outside air damper position is retained, the airflow rate through the OA damper decreases below the Va and Vbz levels. To restore ventilation rates to design levels, the damper positions VENTMIN and VENTMAX must be automatically adjusted when the fan speed changes. The W7220 provides this function when it is configured for 2-speed fan operation through a second set of damper position setpoints.

During operation at High fan speed, the damper setpoint limits are designated VENTMIN H and VENTMAX H. Damper operation is same as described in the DCV with Single-Speed Fan System section, above.

During operation at Low fan speed, the damper setpoint limits change to VENTMIN L and VENTMAX L. These settings are higher than the comparable High speed settings and cause the outside air damper to open more to allow the same Va and Vbz airflow rates to be admitted to the space.

Adjust the DCV setpoints VENTMAX H and VENTMAX L with supply fan speed in High speed and Low speed respectively to provide the design load ventilation airflow rate Vbz by measuring outside air temperature, return air temperature and supply air temperature. Make damper position adjustments with at least 10°F temperature difference between the outdoor and return-air temperatures. See Fig. 74.

To determine the damper setpoint position, perform the following procedure for each condition setpoint, with mechanical cooling OFF:

Calculate the appropriate supply air temperature using the following formula:

$$TS = (TO \times Vbz/CFM) + TR \times (CFM - Vbz)/CFM$$

TS = Supply Air Temperature

TO = Outdoor Air Temperature

Vbz = Design Maximum Ventilation CFM

CFM = Unit Supply Airflow Rate

TR = Return Air Temperature

As an example:

Unit Airflow Rate at High Speed is 4000 CFM

Ventilation CFM at design occupancy Vbz is 1200 CFM

TO = 60°F

TR = 75°F

Required TS = $60 \times (1200/4000) + 75 \times (4000 - 1200)/4000$

= $60 \times 0.30 + 75 \times 0.70 = 18.0 + 52.5$

= 70.5

At the W7220 keypad, enter the parameter SETUP → VENTMAX H and adjust the setpoint value until the observed Supply Air Temperature (MA TEMP) reaches 70.5. Press the ↵ (Enter) button to save this setpoint to controller memory.

When determining VENTMIN setpoints, substitute the value for Va in place of Vbz in the formula.

DCV Setpoint

The SETPOINTS parameter DCV SET defines the space CO₂ level above which the DCV mode begins to open the outside air damper beyond its VENTMIN ventilation lower limit. This setpoint should be a minimum of 100 ppm greater than the outdoor ambient CO₂ level to ensure the outside air will be capable of diluting the space CO₂ level. A typical value for outdoor CO₂ is 400 ppm; adjust the setpoint DCV SET to 500 ppm if outdoor CO₂ level is not known. The factory default value for DCV SET is 1100 ppm.

Economizer Occupancy Control

The 24-v signal that terminates at the W7220's OCC input to place the economizer control in Occupied mode when the supply fan starts is routed through the rooftop unit's Integrated Staging Control (ISC) Board at the board's OCCUPANCY jumper. To implement an occupancy control for the economizer operation, connect a contact set at ISC OCCUPANCY quick-connect terminals and cut jumper JMP1. To allow automatic occupancy mode, close the control contacts. To place the economizer in Unoccupied mode, open the control contacts. See Fig. 75.

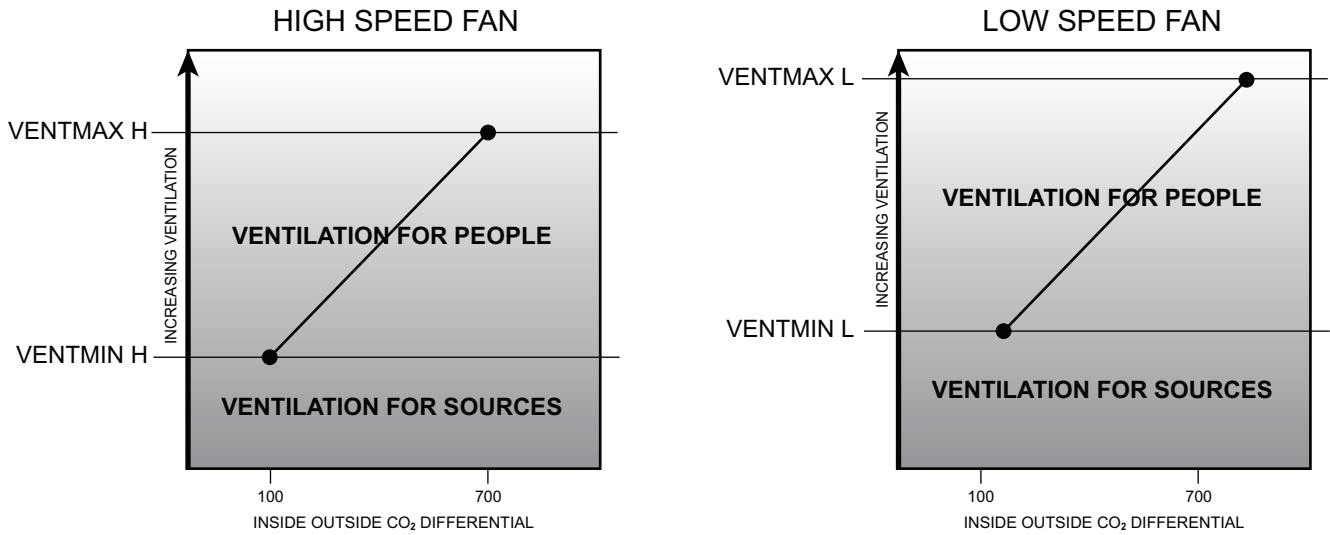

Fig. 74 — DCV 2-Speed System Setpoints (Same Ventilation CFM at Both Speeds)

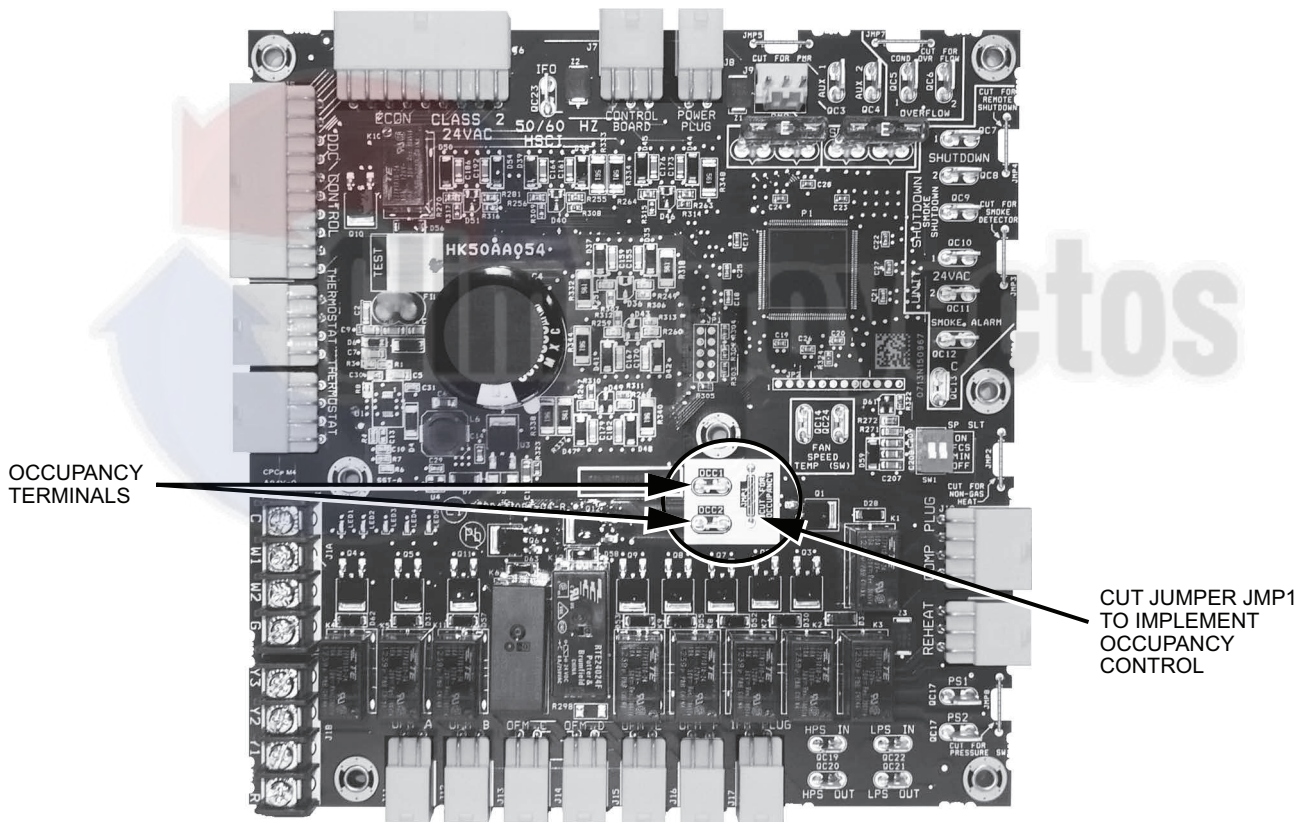

Fig. 75 — Integrated Staging Control (ISC) Board — Occupancy Terminals and Jumper

ECONOMISER HARDWARE

Actuators

The EconoMiSer® X damper actuators are direct-coupled types with spring-return. Power is 24-v from the W7220 outputs. Range of rotation is 95 degrees; timing for full-range movement is 90 seconds to drive open in normal operation, 30 seconds in Test Mode and 25 seconds for spring return.

These actuators are S-bus enabled. The S-bus is a proprietary local equipment network that connects the W7220 controller, one S-enabled actuator and up to three S-type enthalpy sensors on a two-wire communication network. The S-bus is polarity-insensitive. Devices attached to the S-bus are automatically recognized by the controller.

Actuator command position is defined in a 2-10 vdc value. 2.0-v is outside air damper position fully closed (0% open); 10.0-v is damper position fully open (100% open). See Table 11 to correlate control voltage values to outside air damper opening percentage.

These units use a 5-Nm (44 lb-in.) torque model, Honeywell Series MS3105K actuator.

Table 11 — Actuator Voltage vs. Damper Position

Vdc	% OPEN	VDC	% OPEN	VDC	% OPEN
2.0	0	4.8	35	7.6	70
2.4	5	5.2	40	8.0	75
2.8	10	5.6	45	8.4	80
3.2	15	6.0	50	8.8	85
3.6	20	6.4	55	9.2	90
4.0	25	6.8	60	9.6	95
4.4	30	7.2	65	10.0	100

Supply Air Temperature Sensor

The W7220 controller uses a 20k ohm analog sensor for Supply Air Temperature (SAT). The thermistor is attached to a ring terminal. The ring terminal is attached to the unit's supply fan housing, downstream of the unit's indoor coil. The SAT sensor is connected to the W7220 input terminals marked MAT. See Table 12 for sensor resistance to temperature correlations.

The W7220 controller requires a valid signal from its SAT channel in order to function. If the SAT connection to the W7220 is lost, the W7220 will initiate an alarm condition immediately. No economizing operation will be permitted until this alarm is cleared.

Table 12 — SAT/OAT Sensor Characteristics

DEG C	OHMS	DEG F	OHMS
-30	415,156	-20	386,130
-25	301,540	0	193,070
-20	221,210	20	101,820
-15	163,834	32	70,200
-10	122,453	40	55,420
-5	92,382	45	47,771
0	70,200	50	41,258
5	53,806	55	35,725
10	41,561	60	31,035
15	32,341	65	27,069
20	25,346	70	23,719
25	20,000	77	20,000
30	15,886	80	18,473
35	12,698	100	11,544
40	10,212	120	6,768
45	8,261		
50	6,720		

Outside Air Temperature Sensor

EconoMiSer® X systems equipped with outdoor dry bulb temperature changeover control include a 20k ohm analog sensor to measure Outdoor Air Temperature (OAT). This is the same sensor used for the SAT function; see Table 12 for resistance vs temperature characteristics.

The OAT sensor is attached to the outside air damper frame. It is connected to the W7220's OAT input terminals.

If an accessory enthalpy sensor is added to an EconoMiSer X system with factory dry bulb changeover, disconnect this OAT sensor wiring at the W7220's OAT input terminals.

Enthalpy Control Sensor Configuration

The W7220 economizer control system can accommodate up to three S-bus enthalpy sensors. On EconoMiSer X models with factory-installed Enthalpy Changeover control, one S-bus sensor is provided in the economizer outdoor section. Additional sensors may be added to measure return air and discharge air conditions.

The enthalpy control sensor (P/N HH57AC081) communicates with the W7220 economizer controller on the two-wire local equipment network bus (S-bus) and can either be wired using a two-pin header or using a side connector. This sensor is used for all OAT (Outdoor Air Temperature), RAT (Return Air Temperature) and DAT (Discharge Air Temperature), depending on how its three-position DIP switch is set.

Use Fig. 76 and Table 13 to locate the wiring terminals for each Enthalpy Control sensor.

Use Fig. 76 and Table 14 to set the DIP switches for the desired use (location) of the sensor.

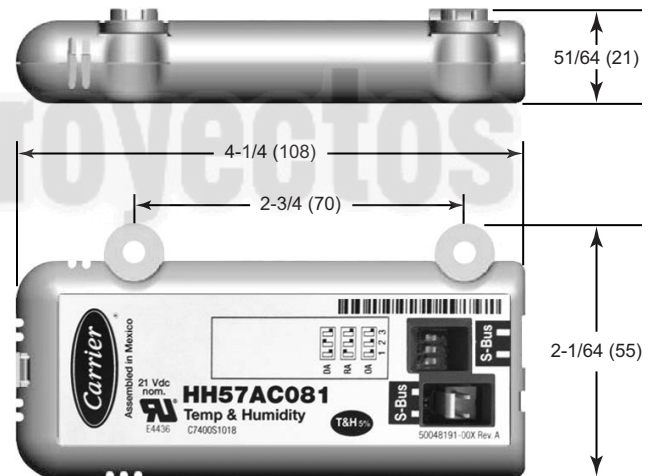

NOTE: Dimensions are in inches. Dimensions in () are in mm.

Fig. 76 — Enthalpy Control Sensor — Dimensions and DIP Switch Locations

Table 13 — Enthalpy Control Sensor Wiring Terminations*

TERMINAL		TYPE	DESCRIPTION
NBR	LABEL		
1	S-BUS	S-BUS	S-Bus Communications (Enthalpy Control Sensor Bus)
2	S-BUS	S-BUS	S-Bus Communications (Enthalpy Control Sensor Bus)

*Terminals are polarity insensitive.

Table 14 — Enthalpy Control Sensor DIP Switch Settings

USE	DIP SWITCH POSITIONS FOR SWITCHES 1, 2, AND 3		
	1	2	3
DA	OFF	ON	OFF
RA	ON	OFF	OFF
OA	OFF	OFF	OFF

LEGEND

- DA = Discharge Air
- RA = Return Air
- OA = Outside Air

When an S-bus sensor is connected to an existing network, it will take 60 minutes for the network to recognize and auto-configure itself to use the new sensor. During the 60 minute setup period, no alarms for sensor failures (except SAT) will be issued and no economizing function will be available.

OPERATING SEQUENCES

Staged Air Volume (3-Speed) Fan Motor

The Integrated Staging Control (ISC) Board in the main unit determines the operating speed (LOW/MED/HIGH) of the indoor fan based on space thermostat demand conditions. See Table 15 for this logic.

Table 15 — Supply Fan Speed Logic Without Economizer

TSTAT OUTPUT	SUPPLY FAN MOTOR SPEED			
	OFF	LOW	MED	HIGH
G/OCC	0 V	24 V	0 V	0 V
Y1	0 V	24 V	0 V	0 V
Y2	0 V	0 V	24 V	0 V
Y3	0 V	0 V	0 V	24 V
W1	0 V	0 V	0 V	24 V
W2	0 V	0 V	0 V	24 V

W7220 Economizer Control

Tables 16 and 17 provide the W7220 Input/Output Logic. Table 16 describes economizer functions for a unit without a CO₂ sensor. Table 17 describes economizer functions for a unit with Demand Controlled Ventilation (CO₂ sensor connected). The supply fan speed is included in these tables for reference; this is neither an input or output of the W7220 controller.

Base Unit Controls

Base unit includes standard electromechanical controls, Staged Air Volume (3-speed supply fan motor with VFD), EconoMiSer[®] X (with W7220 controller) and thermostat or unitary controller that energizes the G terminal in cooling and heating to control the supply fan operation.

Table 16 — W7220 Input/Output without CO₂ Sensor

INPUTS				FAN SPED (REF)*	OUTPUTS			
DEMAND CONTROLLED VENTILATION	OUTSIDE AIR GOOD TO ECONOMIZE	Y1-I	Y2-I		MECHANICAL COOLING STAGE		OCCUPANCY	
					Y1-O/1ST	Y2-O/2ND	OUTSIDE AIR DAMPER POSITION	
						OCC YES	OCC NO	
NO CO ₂ SENSOR	No	Off	Off	Low	0 V/Off	0 V/Off	MIN POS L	Closed
		On	Off	Low	24 V/On	0 V/Off	MIN POS L	Closed
		On	On	High	24 V/On	24 V/On	MIN POS H	Closed
	Yes	Off	Off	Low	0 V/Off	0 V/Off	MIN POS L	Closed
		On	Off	Low	0 V/Off	0 V/Off	Modulating: MIN POS L to Full — Open	Modulating: Closed to Full — Open
		On	On	High	2SP Delay† 24 V/On	0 V/Off**	Modulating: MIN POS H to Full — Open	Modulating: Closed to Full — Open

* Fan Speed for reference only; not an input or output function of the W7220.

† See Menu ADV SETUP —> 2SP FAN DELAY for details.

** See Menu ADV SETUP —> STG# DLY. With Stage 3 enabled, control can turn on second stage cooling Y2-O after delay if the call for Y2-I has not been satisfied.

Table 17 — W7220 Input/Output with Demand Controlled Ventilation (IDCV)

INPUTS				FAN SPED (REF)*	OUTPUTS			
DEMAND CONTROLLED VENTILATION	OUTSIDE AIR GOOD TO ECONOMIZE	Y1-I	Y2-I		MECHANICAL COOLING STAGE		OCCUPANCY	
					OUTSIDE AIR DAMPER POSITION		OCC YES	OCC NO
		Y1-O/1ST	Y2-O/2ND					
Below set	No	Off	Off	Low	0 V/Off	0 V/Off	VENTMIN L	Closed
		On	Off	Low	24 V/On	0 V/Off	VENTMIN L	Closed
		On	On	High	24 V/On	24 V/On	VENTMIN H	Closed
	Yes	Off	Off	Low	0 V/Off	0 V/Off	VENTMIN L	Closed
		On	Off	Low	0 V/Off	0 V/Off	Modulating: VENTMIN L to Full — Open	Modulating: Closed to Full — Open
		On	On	High	2SP Delay† 24 V/On	0 V/Off**	Modulating: VENTMIN H to Full — Open	Modulating: Closed to Full — Open
Above set	No	Off	Off	low	0 V/Off	0 V/Off	Modulating: VENTMIN L to VENTMAX L	Closed
		On	Off	Low	24 V/On	0 V/Off	Modulating: VENTMIN L to VENTMAX L	Closed
		On	On	High	24 V/On	24 V/On	Modulating: VENTMIN H to VENTMAX H	Closed
	Yes	Off	Off	Low	0 V/Off	0 V/Off	Modulating: VENTMIN L to VENTMAX L	Closed
		On	Off	Low	0 V/Off	0 V/Off	Modulating: VENTMIN L to Full — Open	Modulating: Closed to Full — Open
		On	On	High	2SP Delay† 24 V/On	0 V/Off**	Modulating: VENTMIN H to Full — Open	Modulating: Closed to Full — Open

* Fan Speed for reference only; not an input or output function of the W7220.

† See Menu ADV SETUP → 2SP FAN DELAY for details.

** See Menu ADV SETUP → STG# DLY. With Stage 3 enabled, control can turn on second stage cooling Y2-O after delay if the call for Y2-I has not been satisfied.

Cooling, Unit with EconoMiSer® X without CO₂ Sensor

For Occupied mode operation of the EconoMiSer X control, there must be a 24-v signal at terminal G at the unit’s Integrated Staging Control Board from the thermostat; supply fan motor will start and run in Low Speed. The signal at G is connected to W7220 input OCC, placing the EconoMiSer X control in Occupied mode; the economizer actuator is commanded open to the MIN POS L ventilation position. Removing the signal at OCC places the EconoMiSer X control in Unoccupied mode; the economizer actuator is driven back to full-closed position.

When free cooling using outside air is not available, the unit cooling sequence will be controlled directly by the space thermostat. Thermostat call for Stage 1 Cooling energizes ISC terminals G and Y1; supply fan motor starts and runs in Low Speed. The Y1 demand is received at W7220 terminal Y1-I. Outside air damper position will be at MIN POS L. W7220 output Y1-O is energized; first stage mechanical cooling starts.

As space temperature falls and space cooling load is satisfied, the thermostat will remove its call for first stage cooling; ISC terminal Y1 call is removed. The W7220 input Y1-I is removed; output Y1-O is de-energized, stopping first stage cooling.

When ISC terminal Y1 is de-energized, terminal G may remain energized, indicating Continuous Fan operation. The supply fan motor will continue to run in Low Speed. W7220 input OCC remains energized; the outside air damper remains in MIN POS L. If ISC terminal G is also de-energized with Y1, indicating AUTO Fan operation, then the supply fan motor will stop. The W7220 input at OCC is removed; the outside air damper closes.

If the space temperature continues to rise, the thermostat will call for second stage cooling; ISC terminal Y2 is also energized. The supply fan motor shifts to MED Speed. Outside air damper position will remain in MIN POS L, second stage cooling starts.

As space temperature falls, the thermostat will remove its call for second stage cooling; ISC terminal Y2 call is removed. The supply fan motor shifts back to Low Speed. The outside air damper remains at MIN POS L and the ISC board will stop second stage mechanical cooling.

If the space temperature continues to rise, the thermostat will call for third stage cooling; ISC terminal Y-3 is also energized. The supply fan motor shifts to High Speed. The outside air damper position will shift to MIN POS H, third stage cooling starts.

As space temperature falls, the thermostat will remove its call for third stage cooling; ISC terminal Y3 call is removed. The supply fan will shift to Medium Speed. The outside air damper position is repositioned to MIN POS L and stop third stage mechanical cooling.

When free cooling is available as determined by the appropriate changeover command (outdoor dry bulb, outdoor enthalpy, differential dry bulb or differential enthalpy), a space thermostat call for Stage 1 Cooling energizes ISC terminals G and Y1; supply fan motor starts and runs in High Speed. The G demand is received at W7220 input OCC; outside air damper moves to MIN POS L. The Y1 demand is received at W7220 terminal Y1-I. The W7220 economizer control will modulate the outside air damper open and closed to maintain the unit cooling supply air temperature at setpoint MAT SET (default 53°F [12°C]). Compressor will not run.

During free cooling operation, a supply air temperature (SAT) above MAT SET will cause the outside air damper to modulate between MIN POS L setpoint and 100% open. As SAT decreases and approaches setpoint MA LO SET (default 45°F [7°C]), the outside air damper will maintain at the MIN POS L setting. With SAT below MA LO SET, the outside air damper will be closed or at minimum (see FREEZE POS). When SAT rises to MA LO SET plus 3°F, the outside air damper will re-open to MIN POS L setting.

Should 100% outside air not be capable of satisfying the space cooling load, space temperature will rise and the thermostat will call for second stage cooling; ISC terminal Y2 is also energized. The supply fan motor remains at High Speed. Outside air damper position will remain at MIN POS L, starting second stage cooling (Compressor 1 operation). Damper will modulate to maintain SAT at MAT SET concurrent with Compressor 1 operation.

As space temperature falls, the thermostat will remove its call for second stage cooling; ISC terminal Y2 call is removed. The supply fan motor remains High Speed. The outside air damper limit is repositioned to between MIN POS L and 100% open. Second stage cooling (Compressor 1 operation) stops. As space temperature continues to fall and space cooling load is satisfied, the thermostat will remove its call for first stage cooling; ISC terminal Y1 call is removed. The W7220 input Y1-I is removed; free cooling mode ends. Outside air damper will remain at MIN POS L if supply fan remains in operation (CONT FAN) or to closed if supply fan stops (AUTO FAN).

Should 100% outside air and second stage cooling (Compressor 1 operation) not be capable of satisfying the space cooling load, space temperature will rise and the thermostat will call for third stage cooling; ISC terminal Y3 is also energized, starting third stage cooling (Compressor 2 operation). The supply fan motor will remain at High Speed. The Y3 demand is received at W7220 input Y2-I. The outdoor air damper position will modulate from MIN POS H to 100% Open to maintain SAT at MAT SET concurrent with Compressor 2 operation.

As space temperature falls, the thermostat will remove its call for third stage cooling; ISC terminal Y3 call is removed. The supply fan will remain at High Speed. The W7220 input Y2-I is also removed; the outside air damper is repositioned to modulate from MIN POS L to 100% Open, third stage cooling (Compressor 2 operation) stops.

Power Exhaust

If accessory power exhaust is installed, the power exhaust fan motors will be energized by the economizer control as the dampers open above the setpoint EXH1 SET L during Low Speed operation or EXH1 SET H during High Speed fan operation. The EXH1 output will be de-energized as the dampers close below the EXH1 setpoint value.

Damper movement from full closed to full open (or vice versa) will take approximately 1½ minutes.

Heating with EconoMiSer® X

When the space temperature calls for heat (W1 closes), ISC terminal W1 is energized. The supply fan will start and run in High Speed. The W1 signal will connect to W7220 input AUX2I; the outside air damper will move to MIN POS H. Unit heating sequence will follow base unit control sequences.

Demand Controlled Ventilation

If a space or return air CO₂ sensor is connected to the EconoMiSer X control, a Demand Controlled Ventilation strategy will operate automatically.

When the space CO₂ level is below setpoint DCV SET (default 1100 ppm), the minimum ventilation position for the outside air damper will be reset to lower settings suited for offsetting CO₂ loads from space sources not including people. The settings will vary according to supply fan speed. When the supply fan speed is Low, the DCV minimum ventilation point is VENTMIN L. When the supply fan speed is High, the DCV minimum ventilation point is VENTMAX H.

As the CO₂ level in the space increases above the setpoint DCV SET (default 1100 ppm), the DCV ventilation position of the outside air damper will be increased proportionally, until the Maximum Ventilation setting is reached. The settings will vary according to supply fan speed. When the supply fan speed is Low, the DCV maximum ventilation point is VENTMAX L. When the supply fan speed is High, the DCV maximum ventilation point is VENTMAX H.

DCV operation will float between its VENTMIN and VENTMAX settings, never exceeding the VENTMAX limit as the space CO₂ level varies according to changes in people occupancy levels.

During concurrent demand for DCV and free cooling, the outdoor-damper will follow the higher demand condition from the DCV mode or from the free-cooling mode.

W7220 ECONOMIZER SETUP AND CONFIGURATION

Before being placed into service, the W7220 Economizer module must be setup and configured for the installed system according to project control specifications.

IMPORTANT: During setup, the economizer module is live at all times.

Inspect all wiring connections at the Economizer module's terminals, and verify compliance with the installation wiring diagrams. See Fig. 77 for typical wiring.

Initial Menu Display

On initial start up, Honeywell displays on the first line and Economizer W7220 on the second line. After a brief pause, the software revision number appears on the first line and the second line is blank.

Time-Out and Screensaver

When no buttons have been pressed for 10 minutes, the LCD displays a screen saver, which cycles through the Status items. Each Status item displays in turn and cycles to the next item after 5 seconds.

Setup and Configuration Menus

Setup and configuration involves stepping through three menus (SYSTEM SETUP, ADV SETUP and SETPOINTS) to enable required functions, and re-selecting setpoints to meet project requirements. Use the Control Setpoint and Configuration Log on page 63 to record the settings for this specific project.

NOTE: The W7220 controller will be in the "set up" mode for the first 60 minutes after it is powered. If a sensor for OA air or S-bus device (sensor, actuator) is disconnected during the set up mode, the W7220 controller will not signal that failure with an alarm. The SAT sensor is a system "critical" sensor. If the SAT sensor is removed during the set up mode, the W7220 will send an alarm. After 60 minutes the W7220 controller will change to operation mode and all components removed or failed will generate alarms in the operation mode.

For this application with the 2-speed supply fan option, note that parameters EQUIPMENT, AUX2I and FAN TYPE have required settings. Check that these parameters are set at these required settings:

- EQUIPMENT must be CONV
- AUX2I must be W
- FAN SPEED must be 2SPEED

Press the **⬆** (Exit) button exit the SYSTEM SETUP menu and return to top level menu. Scroll down to ADV SETUP menu and press the **⬇** (Enter) button to enter this menu. Scroll down through the list of parameters and adjust settings as required. Be sure that the message CHANGE STORED appears with every change in parameter setting.

Press the **⬆** (Exit) button exit the ADV SETUP menu and return to top level menu. Scroll down to SETPOINTS menu and press the **⬇** (Enter) button to enter this menu. Scroll down through the list of parameters and adjust settings as required. Be sure that the message CHANGE STORED appears with every change in parameter setting.

SETPOINT Defaults

The default setpoint values represent many years of successful experience with economizing systems. Any changes that represent significant deviations from the default values should be well considered.

DCV SETPOINT

The default value for DCV SET is 1100 ppm. It is recommended that this setpoint be adjusted down to 500 ppm (or CO₂ level of outdoor air plus 100 ppm, whichever is higher) to permit an earlier initiation of the DCV mode as space occupancy increases.

Checkout

For checkout, review the Status of each configured parameter by observing the scrolling display from the Screensaver mode or by entering the STATUS menu.

Use the Checkout menu (see Table 7 on page 48) to test the damper operation and any configured outputs. Only items that are configured are shown in the Checkout menu.

⚠ CAUTION

EQUIPMENT DAMAGE HAZARD

Failure to follow this caution may result in equipment damage.

Be sure to allow enough time for compressor start-up and shutdown between checkout tests so that you do not short-cycle the compressors.

To perform a Checkout test:

1. Scroll to the desired test in the Checkout menu using the ▲ and ▼ buttons.
2. Press the ↵ (Enter) button to select the item. RUN? appears.
3. Press the ↵ (Enter) button to start the test. The unit pauses, then displays IN PROGRESS. When the test is complete, DONE appears.
4. When all desired parameters have been tested, press the ⬆ (Menu up) button to end the test.

The Checkout tests can all be performed at the time of installation or at any time during the operation of the system as a test that the system is operable.

Status

Use the STATUS menu (see Table 7 on page 48) to check the parameter values for the various devices and sensors configured.

Calibration of Sensors

Up to six sensor calibration settings are available in the ADV SETUP menu (depending on which sensors are connected to the W7220). See Table 7 on page 48 for this menu.

Resetting All Defaults

The SYSTEM SETUP menu contains the parameter FACTORY DEFAULT. This parameter will reset all setpoints back to factory default values.

To reset all values to defaults, scroll to the SYSTEM SETUP menu, enter the menu and scroll to parameter FACTORY DEFAULT. Enter this parameter and change the display value from NO to YES. Press the ↵ (Enter) button.

After resetting all values, scroll up in SYSTEM SETUP to ensure the three parameters requiring special values for use with 2-speed fan system are correct:

- EQUIPMENT must be CONV
- AUX2I must be W
- FAN SPEED must be 2SPEED

TROUBLESHOOTING

Power Up Delay

Upon power up (or after a power outage or brownout) the W7220 controller module begins a 5-minute power up delay before enabling mechanical cooling.

Power Loss (Outage or Brownout)

All setpoints and advanced settings are restored after any power loss or interruption.

NOTE: If the power goes below 18 Vac, the W7220 controller module assumes a power loss and the 5-minute power up delay will become functional when power returns above 18 Vac.

Alarms

The economizer module provides alarm messages that display on the 2-line LCD.

NOTE: Upon power up, the module waits 60 minutes before checking for alarms. This allows time for all the configured devices (e.g. sensors, actuator) to become operational. The exception is the SAT sensor which will alarm immediately.

If one or more alarms are present and there has been no keypad activity for at least 5 minutes, the Alarms menu displays and cycles through the active alarms. You can also navigate to the Alarms menu at any time. The list of alarms included in Table 7 on page 48 is not a complete list of available alarm messages. Each sensor has alarms for temperature, humidity and enthalpy. The list of possible alarms will vary from unit to unit as different sensors are connected.

Clearing Alarms

Once the alarm has been identified and the cause has been removed (e.g. replaced faulty sensor) the alarm can be cleared from the display.

To clear an alarm, perform the following:

1. Navigate to the desired alarm.
2. Press the ↵ (Enter) button. ERASE? displays.
3. Press the ↵ (Enter) button. ALARM ERASED displays.
4. Press the ⬆ (Menu up/Exit) button to complete the action and return to the previous menu.

NOTE: If the alarm still exists after clearing it, it is redisplayed within 5 seconds.

See Table 18 for troubleshooting suggestions.

Table 18 — Operating Issues and Concerns

ISSUE OR CONCERN	POSSIBLE CAUSE AND REMEDY
My outdoor temperature reading on the STATUS menu is not accurate.	Check the sensor wiring: <ul style="list-style-type: none"> • Enthalpy sensors are to be wired to the S-Bus terminals. • Temperature sensors are to be wired to the OAT and MAT terminals. See Fig. 77.
If my enthalpy sensor drifts in accuracy over time, can I re-calibrate it?	Sensors cannot be re-calibrated in the field. However, the ADVANCED menu includes an item where you can input a limited offset in temperature and humidity for each sensor connected to the economizer.
Can I go back to factory defaults and start over?	Under the SYSTEM SETUP menu you can change the setpoints to the factory defaults.
Will I be able to see the LCD screen when it is in the unit?	The LCD screen has a backlight that is always illuminated.
What is a good setpoint for the Supply Air Temperature (SAT)?	The supply air temperature is the temperature of air that you want to supply to the space. In a commercial building, this is 50°F to 55°F (10°C to 13°C). The supply air is the mixing of the return air and the outdoor air.
I am using enthalpy sensors. Why did the control ask me to input a dry bulb changeover temperature?	If the humidity sensor in the enthalpy sensors fails, the backup algorithm in the control is to default to the temperature sensor in the enthalpy sensor.
In checkout, the outdoor damper closes when I command it to open.	Check the actuator linkage or rotation. In the CHECKOUT mode, the outdoor damper should drive open or closed with the return air damper having the opposite effect.
How do I set the minimum position?	The minimum position is set using the VENTMIN and VENTMAX setup in the SETPOINTS menu. VENTMIN is the minimum ventilation required when using an occupancy sensor and VENTMAX is the minimum ventilation when not using an occupancy sensor for Demand Controlled Ventilation. The VENTMAX position is set the same as with the potentiometer on the analog economizers, and is the output voltage to the damper actuator. The range is 2 Vdc closed OA damper and 10 Vdc open OA damper.
What if my damper does not go completely closed in the checkout operation?	Check the damper linkage or hub to make sure the damper is able to close completely.
How do I set the OCC?	There are two settings for OCC, INPUT and ALWAYS. INPUT is from the space thermostat, if it has an occupancy output. ALWAYS is the unit in the occupied mode, if the economizer is powered (fan on).
Does the economizer save my program values if the unit loses power?	Yes, once the changes are stored in the controller they will be stored until they are changed by the operator.
If the unit is left in checkout, how long will the unit stay in checkout mode without input?	The unit will remain in checkout for 10 minutes, then return to normal operation.

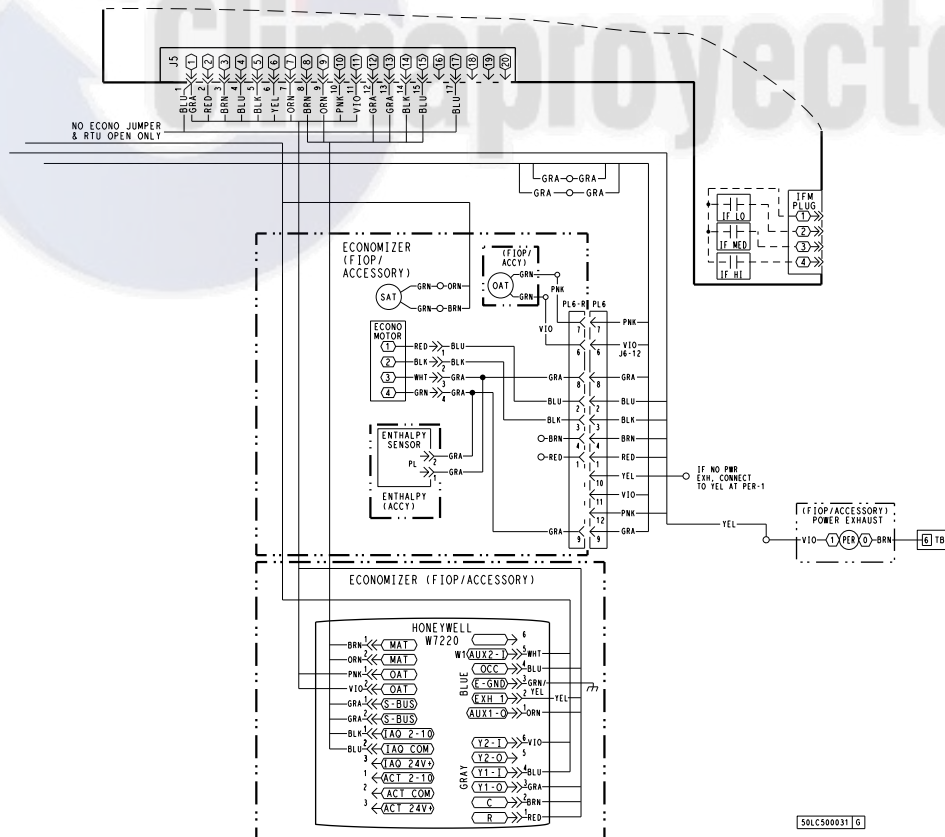

Fig. 77 — Typical Economizer® X Wiring Diagram

CONTROL SETPOINT AND CONFIGURATION LOG

Project Name/Location: _____

Model Number: _____

Serial Number: _____

Date: _____

Technician: _____

Menu Tables:

1. SYSTEM SETUP
2. ADVANCED SETUP
3. SETPOINTS

Menu 1: System Setup

PARAMETER	PROJECT VALUE	PARAMETER DEFAULT VALUE	PARAMETER RANGE AND INCREMENT	NOTES
INSTALL		01/01/10		Display order = MM/DD/YY Setting order = DD, MM, then YY
UNITS DEG		°F	°F or °C	Sets economizer controller in degrees Fahrenheit or Celsius.
EQUIPMENT		CONV	CONV required for 2-speed mode	CONV = conventional; HP O/B = Enable Heat Pump mode; not available with 2-speed See Table 7 on page 48, Menu Note 4.
AUX2 I		W	W required for 2-speed mode	W = Informs controller that system is in heating mode. SD = Enables configuration of shutdown (not available on 2-speed) See Table 7 on page 48, Menu Note 4.
FAN TYPE		2speed	2 speed required	Sets the economizer controller for operation of 1 speed or 2 speed indoor fan system. See Table 7 on page 48, Menu Note 4.
FAN CFM		5000cfm	100 to 15000 cfm	UNIT DESIGN AIRFLOW (CFM) Enter ONLY if using DCVCAL ENA = AUTO The value is found in the Project Submittal documents for the specific RTU.
AUX OUT		NONE	NONE ERV EXH2 SYS	Select OUTPUT for AUX1 O relay: NONE = not configured (output is not used) ERV = Energy Recovery Ventilator EXH2 = second damper position relay closure for second exhaust fan SYS = use output as an alarm signal
OCC		INPUT	INPUT or ALWAYS	OCCUPIED MODE BY EXTERNAL SIGNAL When using a setback thermostat with occupancy out (24 Vac), the 24-Vac is input to the OCC terminal. RTU control circuit provides 24-Vac to OCC through OCCUPIED terminals on Integrated Staging Control Board.
FACTORY DEFAULT		NO	NO or YES	Resets all set points to factory defaults when set to YES. LCD will briefly flash YES and change to NO but all parameters will change to the factory default values. <i>RECHECK AUX2 I and FANTYPE for required 2-speed values.</i>

Menu 2: Advanced Setup

PARAMETER	PROJECT VALUE	PARAMETER DEFAULT VALUE	PARAMETER RANGE AND INCREMENT	NOTES
MA LO SET		45°F (7°C)	35 to 55°F (2 to 13°C); incremented by 1°	SUPPLY AIR TEMPERATURE LOW LIMIT Temperature to achieve Freeze Protection (close damper and alarm if temperature at SAT location falls below setup value)
FREEZE POS		CLO	CLO or MIN	FREEZE PROTECTION DAMPER POSITION Damper position when freeze protection is active CLO =closed MIN = MIN POS or VENTMAX
CO2 ZERO		0ppm	0 to 500 ppm; increment by 10	CO ₂ ppm level to match CO ₂ sensor start level.
CO2 SPAN		2000ppm	1000 to 3000 ppm; increment by 50	CO ₂ ppm span to match CO ₂ sensor.
STG3 DLY		2.0h	0 min, 5 min, 15 min, then 15 min intervals. Up to 4 h or OFF	COOLING STAGE 3 DELAY Delay after stage 2 for cool has been active. Turns on second stage of cooling when economizer is first stage and mechanical cooling is second.
SD DMPR POS		CLO	CLO or OPN	Function NOT AVAILABLE with 2-speed mode
DCVCAL ENA		MAN	MAN (manual)	Turns on the DCV automatic control of the dampers. Resets ventilation.
MAT T CAL	0.0	1.0°F (or °C)	± 2.5°F (± 1.4°C)	SUPPLY AIR TEMPERATURE CALIBRATION Allows the operator to adjust for an out of calibration supply air temperature (SAT) sensor.
OA T CAL	2.0	3.0°F (or °C)	± 2.5°F (± 1.4°C)	OUTSIDE AIR TEMPERATURE CALIBRATION Allows the operator to adjust for an out of calibration outside air temperature (OAT) sensor
OA H CAL		0% RH	± 10% RH	OUTSIDE AIR HUMIDITY CALIBRATION Allows the operator to adjust for an out of calibration of outside air enthalpy sensor
RA T CAL	4.0	5.0°F (or °C)	± 2.5°F (± 1.4°C)	RETURN AIR TEMPERATURE CALIBRATION Allows the operator to adjust for an out of calibration return air temperature (RA) sensor
RA H CAL		0% RH	± 10% RH	RETURN AIR HUMIDITY CALIBRATION Allows the operator to adjust for an out of calibration return air enthalpy sensor
DA T CAL	0.0	1.0°F (or °C)	± 2.5°F (± 1.4°C)	DISCHARGE AIR TEMPERATURE CALIBRATION Allows the operator to adjust for an out of calibration discharge air temperature (DAT) sensor
2SP FAN DELAY		5 minutes	0 to 20 minutes in 1 minute increments	TIME DELAY ON SECOND STAGE ECONOMIZING While in the Economizing mode, this is the delay between thermostat Y2 call and Y1-O output to mechanical cooling stage, to allow high speed fan operation to attempt to cool space first.

Menu 3: Setpoints

PARAMETER	PROJECT VALUE	PARAMETER DEFAULT VALUE	PARAMETER RANGE AND INCREMENT	NOTES
MAT SET		53°F (12°C)	38 to 65°F (3 to 18°C); increment by 1°	SUPPLY AIR SETPOINT Setpoint determines where the economizer will modulate the OA damper to maintain the supply air temperature. See Table 7 on page 48, Menu Note 2.
LOW T LOCK		32°F (0°C)	-45 to 80°F (-43 to 27°C); increment by 1°	COMPRESSOR LOW TEMPERATURE LOCKOUT Setpoint determines outdoor temperature when the mechanical cooling cannot be turned on.
DRYBLB SET		63°F (17°C)	48 to 80°F (9 to 27°C); increment by 1°	OA DRY BULB TEMPERATURE CHANGEOVER SETPOINT Setpoint determines where the economizer will assume outdoor air temperature is good for free cooling; e.g.: at 63°F (17°C), unit will economize at 62°F (16.7°C) and below and not economize at 64°F (17.8°C) and above. There is a 2°F (1.1°C) deadband. See Table 7 on page 48, Menu Note 3.
ENTH CURVE		ES3	ES1, ES2, ES3, ES4, or ES5	ENTHALPY CHANGEOVER CURVE (Requires enthalpy sensor option) Enthalpy boundary "curves" for economizing using single enthalpy
DCV SET		1100ppm	500 to 2000 ppm; increment by 100	DEMAND CONTROLLED VENTILATION SETPOINT Displays only if CO ₂ sensor is connected. Setpoint for Demand Controlled Ventilation of space. Above the setpoint, the OA dampers will modulate open to bring in additional OA to maintain a space ppm level below the setpoint.
MIN POS L		6.0 V	2 to 10 Vdc	VENTILATION MINIMUM POSITION AT LOW SPEED Displays ONLY if a CO ₂ sensor is NOT connected.
MIN POS H		4.4 V	2 to 10 Vdc	VENTILATION MINIMUM POSITION AT HIGH SPEED Displays ONLY if a CO ₂ sensor is NOT connected.
VENTMAX L		6.0 V	2 to 10 Vdc	DCV MAXIMUM DAMPER POSITION AT LOW SPEED (Requires CO ₂ sensor connected)
VENTMAX H		4.4 V	2 to 10 Vdc	DCV MAXIMUM DAMPER POSITION AT HIGH SPEED (Requires CO ₂ sensor connected)
VENTMIN L		3.7 V	2 to 10 Vdc	DCV MINIMUM DAMPER POSITION AT LOW SPEED (Requires CO ₂ sensor connected)
VENTMIN H		2.8 V	2 to 10 Vdc	DCV MINIMUM DAMPER POSITION AT HIGH SPEED (Requires CO ₂ sensor connected)
ERV OAT SP		32°F (0°C)	0 to 50°F (-18 to 10°C); increment by 1°	ENERGY RECOVERY VENTILATION UNIT OUTDOOR AIR TEMPERATURE SETPOINT Only when AUX1 O = ERV
EXH1 L SET		65%	0 to 100%; increment by 1	EXHAUST FAN STAGE 1 SETPOINT AT LOW SPEED Setpoint for OA damper position when exhaust fan1 is powered by the economizer.
EXH1 H SET		50%	0 to 100%; increment by 1	EXHAUST FAN STAGE 1 SETPOINT AT HIGH SPEED Setpoint for OA damper position when exhaust fan1 is powered by the economizer.
EXH2 L SET		80%	0 to 100%; increment by 1	EXHAUST FAN STAGE 2 SETPOINT AT LOW SPEED Setpoint for OA damper position when exhaust fan 2 is powered by the economizer. Only used when AUX1-O is set to EHX2.
EXH2H SET		75%	0 to 100%; increment by 1	EXHAUST FAN STAGE 2 SETPOINT AT HIGH SPEED Setpoint for OA damper position when exhaust fan 2 is powered by the economizer. Only used when AUX1-O is set to EHX2.

Staged Air Volume (SAV™) with Variable Frequency Drive

The Staged Air Volume (SAV) system utilizes a Variable Frequency Drive (VFD) to automatically adjust the indoor fan motor speed in sequence with the unit's ventilation, cooling and heating operation. Per ASHRAE 90.1-2016 standard, during the first stage of cooling operation the SAV system will adjust the fan motor to provide 66% of the design airflow rate for the unit. When the call for the second stage of cooling is required, the SAV system will allow the design airflow rate for the unit established (100%). During the heating mode, the SAV system will allow total design airflow rate (100%) operation. During ventilation mode, the SAV system will operate the fan motor at 66% speed. Figure 78 shows the Variable Frequency Drive. See Fig. 79 for the VFD location.



Fig. 78 — Variable Frequency Drive (VFD)

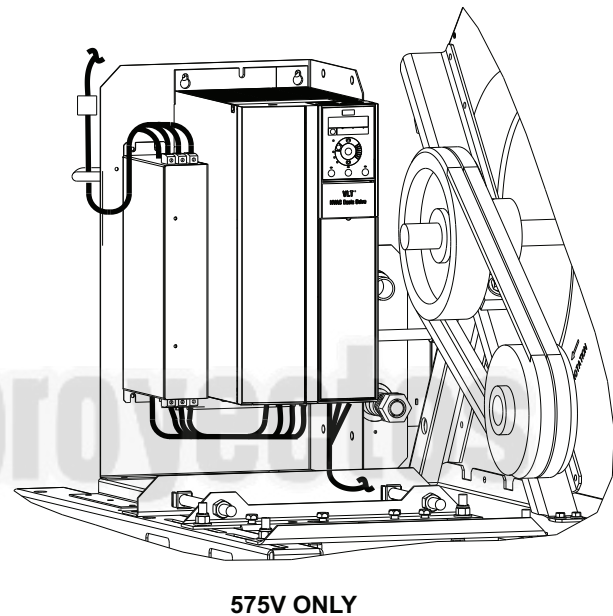
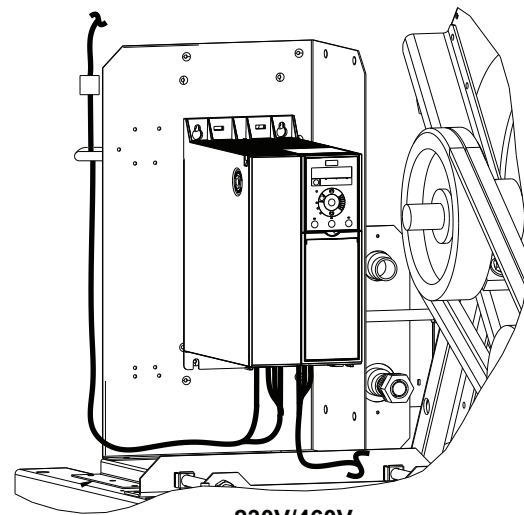

Fig. 79 — VFD Location

MULTI-SPEED VFD DISPLAY KIT (FIELD-INSTALLED ACCESSORY)

NOTE: The Remote VFD Keypad is part of the Multi-Speed VFD display kit (P/N: CRDISKIT002A00), which is a field-installed accessory. It is not included with the 50LC size 14-26 base units.

The VFD keypad as shown in Fig. 80 consists of the following sections:

Alphanumeric Display

The LCD display is backlit with 2 alphanumeric lines. All data is displayed on the LCD (see Fig. 81).

Menu Key

Use the Menu key to select between Status, Quick Menu or Main Menu. The triangle icon at the bottom of the LCD display indicates the currently selected mode (see number 5 in Fig. 81).

Navigation Keys and Status LEDs

The Navigation keys and Status LEDs are detailed in Fig. 82.

Operation Keys and LEDs

Figure 83 details the functions of the Operating keys. An illuminated yellow LED above the key indicates the active key.

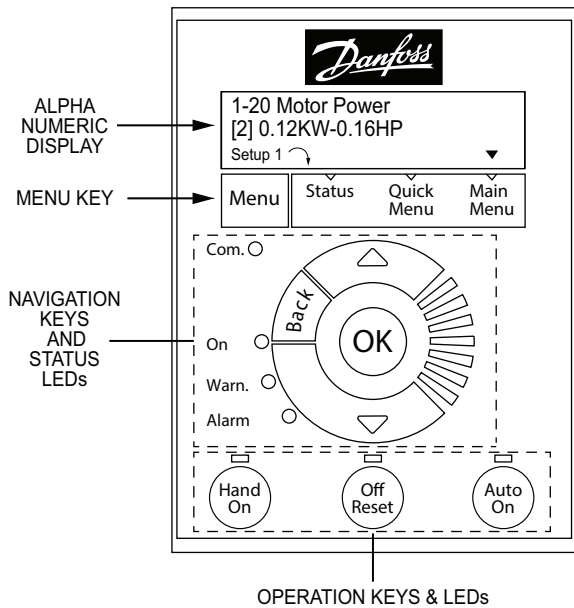
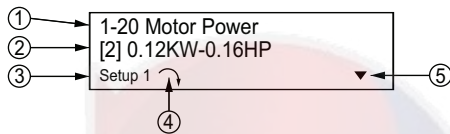
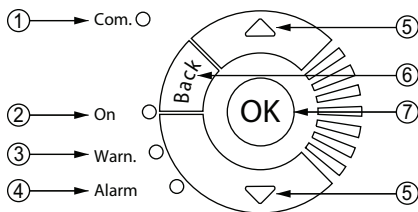

Fig. 80 — VFD Keypad



- 1 = Parameter number and name.
- 2 = Parameter value.
- 3 = Setup number shows the active setup and the edit setup. If the same setup acts as both the active and edit setup, only that setup number is shown (factory setting). When the active and edit setup differ, both numbers are shown in the display (SETUP 12). The flashing number indicates the edit setup.
- 4 = The symbol in the number 4 position in the figure above indicates motor direction. The arrow points either clockwise or counter-clockwise to show the motor's current direction.
- 5 = The position of the triangle indicates the currently selected menu: Status, Quick Menu or Main Menu.

Fig. 81 — Alphanumeric Display



- 1 = Com. LED: Flashes when bus communications is communicating.
- 2 = Green LED/On: Control selection is working.
- 3 = Yellow LED/Warn.: Indicates a warning.
- 4 = Flashing Red LED/Alarm: Indicates an alarm.
- 5 = Arrows: Use the Up and Down arrow keys to navigate between parameter groups, parameters and within parameters. Also used for setting local reference.
- 6 = Back key: Press to move to the previous step or layer in the navigation structure.
- 7 = OK key: Press to select the currently displayed parameter and for accepting changes to parameter settings.

Fig. 82 — Navigation Keys and Status LEDs

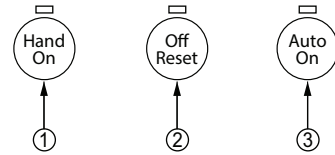

- 1 = Hand On key: Starts the motor and enables control of the variable frequency drive (VFD) via the VFD Keypad option. NOTE: Please note that terminal 27 Digital Input (5-12 Terminal 27 Digital Input) has coast inverse as default setting. This means that the Hand On key will not start the motor if there is no 24V to terminal 27, so be sure to connect terminal 12 to terminal 27.
- 2 = Off/Reset key: Stops the motor (off). If in alarm mode the alarm will be reset.
- 3 = Auto On key: The variable frequency drive is controlled either via control terminals or serial communication.

Fig. 83 — Operation Keys and LEDs

Connecting the Keypad to the VFD

The VFD keypad can be mounted directly to the variable frequency drive, provided you can easily access the front panel of the VFD. If you do not have easy access to the VFD front panel, use the cable included with the kit to connect the keypad to the VFD.

Connecting the Keypad Directly to the VFD

1. Place the bottom of the VFD keypad into the variable frequency drive as shown in Fig. 84.

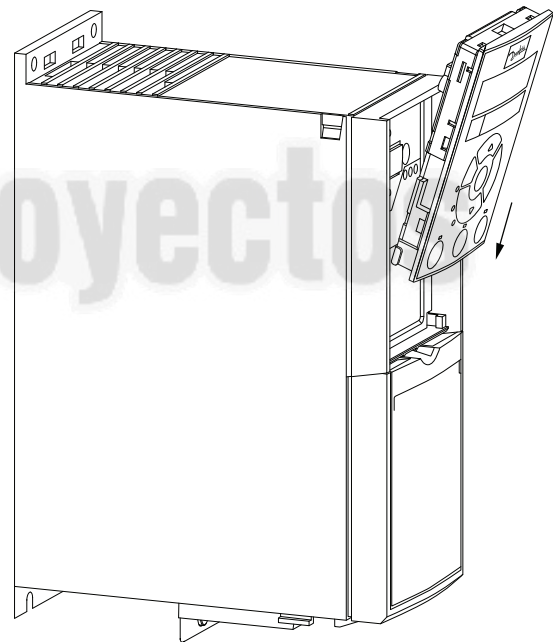

Fig. 84 — Aligning Bottom of VFD Keypad with Opening in VFD Front Panel

2. Push the top of the VFD keypad into the variable frequency drive as shown in Fig. 85.

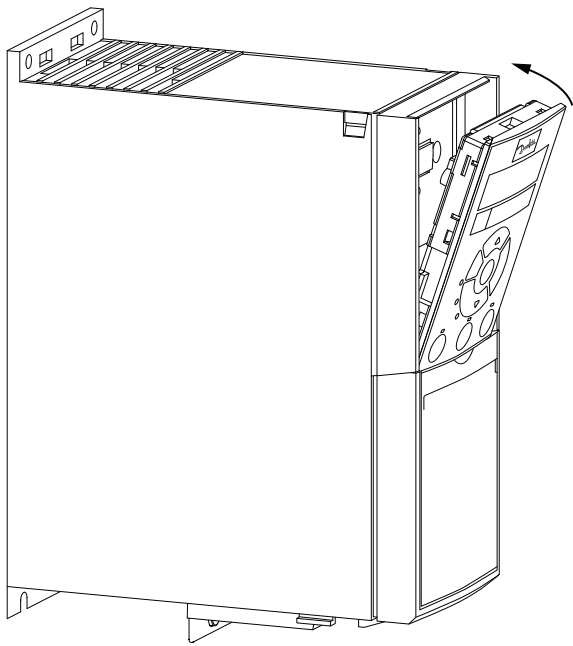

Fig. 85 — Secure Keypad in Place

Using the Cable to Connect the Keypad with the VFD

The VFD keypad can be connected to the variable frequency drive via the cable included with the Multi-Speed VFD display kit (P/N CRDISKIT002A00). See Fig. 86.

1. Connect the male end of the cable to the front panel of the variable frequency drive. Use 2 of the screws included with the kit to secure the cable to the VFD.
2. Connect the female end of the cable to the back panel of the VFD Remote keypad. Secure the cable to the remote keypad using the 2 remaining screws from the kit.

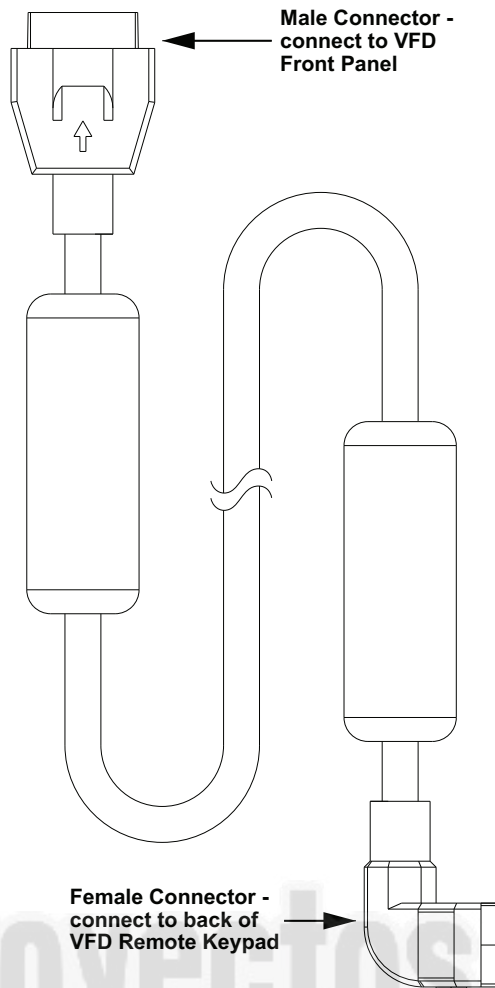

Fig. 86 — VFD Remote Keypad Cable

Program the VFD for 3 Discrete Indoor Fan Speeds

IMPORTANT: 50LC 14-26 units are programmed at the factory for 3 discrete indoor fan speeds. The following procedure is only to be used to recover this function after an event such as a system crash.

NOTE: This procedure requires use of the VFD Keypad which is included as part of the field-installed Multi-Speed VFD display kit (P/N CRDISKIT002A00). If the VFD keypad is not already installed, install it. See “Connecting the Keypad to the VFD” on page 67 for details.

1. At power-up: At the first power-up, the LCD displays the Select Language screen. The default setting is English. To change the language, press the **OK** key and use the ▲ (Up arrow) and ▼ (Down arrow) keys to scroll to the desired language. Then press **OK**. See Fig. 87.

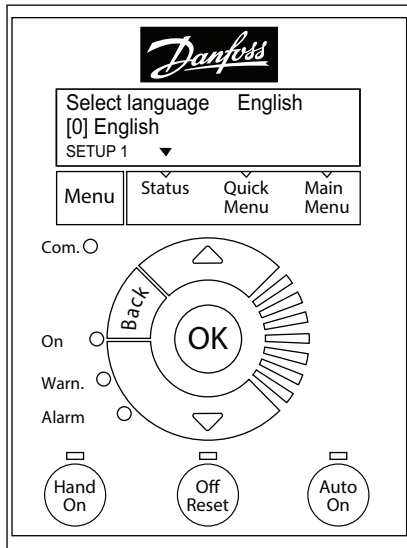

Fig. 87 — Keypad with Power Up Screen Displayed

2. Select Regional Settings:

- a. Press the **Off Reset** key.
- b. Press the Menu key to move the ▼ (triangle icon) so it is positioned over the Main Menu. The display shows the following:

0 —** Operation/Display
1 —** Load and Motor

- c. Press the **OK** key. The display changes to:

0 —0* Basic Settings
0 —1* Set-up Operations

- d. With the top row highlighted, press **OK**. The display changes to:

0 —01 Language
[0] English

NOTE: If English is not the desired language, press **OK**, select the desired language, and press **OK** again.

- e. Press ▼ (Down arrow key) once. The display changes to:

0 —03 Regional Settings
[0] International

- f. Press **OK**. The [0] is now highlighted.
- g. Press ▼ (Down arrow key) once. The display changes to:

0 —03 Regional Settings
[1] North America

- h. Press **OK**.

NOTE: If Alarm 060 appears, follow Step 3 to clear the alarm. be sure to press **Off Reset** when done. If there is no alarm, continue at Step 4.

3. Clear Alarm 060 (External Interlock):

- a. Press the Menu key twice to position the ▼ (triangle icon) over the Main Menu. The display changes to:

0 —** Operation/Display
1 —** Load and Motor

- b. Press the ▼ (Down arrow key) until the following display appears:

0 —** Limits/Warnings
5 —** Digital In/Out

- c. Press **OK**. The display changes to:

5 —0* Digital I/O Mode
5 —1* Digital Inputs

- d. Press ▼ (Down arrow key) once to highlight the bottom row, and press **OK**. The display changes to:

5 —10 Terminal 18 Digital In...
[8] Start

- e. Press ▼ (Down arrow key) twice. The following display appears:

5 —12 Terminal 27 Digital In...
[7] External Interlock

- f. Press **OK** to highlight the number in the brackets.
- g. Press ▼ (Down arrow key) until the following display appears:

5 —12 Terminal 27 Digital In...
[0] No operation

- h. Press **OK**.
- i. Press **Off Reset**. The Alarm indicator disappears.

4. Enter Grid Type:

- a. Press the Menu key to move the ▼ (triangle icon) so it is positioned over the Main Menu. The display shows the following:

0 —0* Basic Settings
1 —1* Set-up Operations

- b. Press **OK** twice. The display changes to:

0 —01 Language
[0] English

- c. Press ▼ (Down arrow key) three times to reach the following display:

0 —06 Grid Type
[102] 200-240V/60Hz

- d. Press **OK** to highlight the number in the brackets; then use the ▲ (Up arrow) and ▼ (Down arrow) keys to select the desired voltage and Hertz for the unit.

- e. Press **OK** to accept the selection and continue.

5. Enter Motor Data:

- a. Press the Menu key to move the ▼ (triangle icon) so it is positioned over the Main Menu. The display shows the following:

0 —** Operation/Display
1 —** Load and Motor

- b. Press ▼ (Down arrow key) once to highlight the bottom row.

- c. Press **OK**. The display changes to:

1 —0* General Settings
1 —1* Motor Selection

- d. Press ▼ (Down arrow key) twice to reach the following display:

1 —1* Motor Selection
1 —2* Motor Data

e. Press **OK**. The following display appears:

1 —20 Motor Power
[9] 1.5kW — 2 hp

NOTE: The number in the brackets may be different from the one shown above.

f. Press **OK**; then use the ▲ (Up arrow) and ▼ (Down arrow) keys to scroll to the proper motor horsepower. Press **OK** again to set the selected hp.

g. Press ▼ (Down arrow) once to display the following:

1 —22 Motor Voltage
230V

h. Press **OK** to highlight the voltage value; then use the ▲ (Up arrow) and ▼ (Down arrow) keys to select the nameplate voltage. Press **OK** again to set the selected voltage.

i. Press ▼ (Down arrow) once to display the following:

1 —23 Motor Frequency
60Hz

j. Press **OK** to highlight the frequency value; then use the ▲ (Up arrow) and ▼ (Down arrow) keys to select the nameplate Hz. Press **OK** again to set the selected Hz.

k. Press ▼ (Down arrow) once to display the following:

1 —24 Motor Current
6.61A

l. Press **OK** to highlight the current value; then use the ▲ (Up arrow) and ▼ (Down arrow) keys to select the Max Amps value provided. Press **OK** again to set the Max Amps.

NOTE: The Max Amps is greater than the nameplate value. Check the VFD Unit Parameters (see Tables 19-23 beginning on page 73) and use the value listed for the given unit in the column labeled “Motor Current Must-Hold Amps”.

m. Press ▼ (Down arrow) once to display the following:

1 —25 Motor Nominal Speed
1740rpm

n. Press **OK** to highlight the rpm value; then use the ▲ (Up arrow) and ▼ (Down arrow) keys to select the nameplate rpm. Press **OK** again to set the selected rpm.

6. Enter parameters for 1-71, 1-73, 1-82, and 1-90:

a. Press the Menu key to move the ▼ (triangle icon) so it is positioned over the Main Menu. The display shows the following:

0 —** Operation/Display
1 —** Load and Motor

b. Press ▼ (Down arrow key) once to highlight the bottom row.

c. Press **OK**. The display changes to:

1 —0* General Settings
1 —1* Motor Selection

d. Press ▼ (Down arrow key) until the following display appears:

1—6* Load Depen.Setting
1 —7* Start Adjustments

e. Press **OK**. The following display appears:

1 —71 Start Delay
2.0s

f. Press **OK** to highlight the number; then use the ▲ (Up arrow) and ▼ (Down arrow) keys to select the number provided in Tables 19-23 beginning on page 73. Press **OK** again to set the selected value.

g. Press ▼ (Down arrow) twice. The following display appears:

1 —73 Flying Start
[1] Enabled

h. Press **OK** to highlight the number in brackets; then use the ▲ (Up arrow) and ▼ (Down arrow) keys to select the number provided in Tables 19-23 beginning on page 73. Press **OK** again to set the selected value.

i. Press the **Back** key once. The following display appears:

1—6* Load Depen. Setting
1—7* Start Adjustments

j. Press ▼ (Down arrow key) once. The following display appears:

1—7* Start Adjustments
1—8* Stop Adjustments

k. Press **OK**. The following display appears:

1 —80 Function at Stop
[0] Coast

l. Press ▼ (Down arrow) once. The following display appears:

1 —82 Min Speed for Function...
1.0 Hz

m. Press **OK** to highlight the number; then use the ▲ (Up arrow) and ▼ (Down arrow) keys to select the number provided in Tables 19-23 beginning on page 73. Press **OK** again to set the selected value.

n. Press the **Back** key once. The following display appears:

1—7* Start Adjustments
1—8* Stop Adjustments

o. Press ▼ (Down arrow key) once. The following display appears:

1—8* Stop Adjustments
1—9* Motor Temperature

p. Press **OK**. The following display appears:

1 —90 Motor Thermal Prote...
[4] ETR Trip 1

q. Press **OK** to highlight the number in brackets; then use the ▲ (Up arrow) and ▼ (Down arrow) keys to select the number provided in Tables 19-23 beginning on page 73. Press **OK** again to set the selected value.

7. Set References:

a. Press the Menu key to move the ▼ (triangle icon) so it is positioned over the Main Menu. The display shows the following:

0 —** Operation/Display
1 —** Load and Motor

b. Press ▼ (Down arrow key) three times. The following display appears:

2—** Brakes
3—** Reference/Ramps

c. Press **OK**. The display changes to:

3—0* Reference Limits
3—1* References

d. Press **OK** again. The following display appears:

3—02 Minimum Reference
0.000

NOTE: If the bottom row displays a number other than 0.000, press **OK** and use the ▲ (Up arrow) and ▼ (Down arrow) keys to select 0.000.

e. Press ▼ (Down arrow key) once. The following display appears:

3—03 Maximum Reference
60.000

NOTE: If the bottom row displays a number other than 60.000, press **OK** and use the ▲ (Up arrow) and ▼ (Down arrow) keys to select 60.000.

f. Press the **Back** key until the following display appears:

3—0* Reference Limits
3—1* References

g. Press ▼ (Down arrow key) once to move the highlight to the bottom row, then press **OK**. The following display appears:

3—10 Preset Reference
[0]0.00%

h. Press **OK** once to highlight the number in brackets. Press **OK** again. The highlight moves to the current percent value. Use the ▲ (Up arrow) and ▼ (Down arrow) keys and the following table to enter the required Preset Reference values:

[0]0.00%	Stop
[1]LL.LL%	Low Speed (see Tables 19-23, column labeled "Preset References 3-10[1]" for the proper % for each unit)
[2]MM.MM%	Medium Speed (see Tables 19-23, column labeled "Preset References 3-10[2]" for the proper % for each unit)
[3]100%	Override (High Speed)
[4]100%	High Speed (100% or close to 100% to achieve the required CFM at high speed)
[5]100%	Stop
[6]100%	Stop
[7]100%	Stop

8. Set the Ramp Time:

a. Press the **Back** key until the following display appears:

3—0* Reference Limits
3—1* References

b. Press ▼ (Down arrow key) twice. The following display appears:

3—1* References
3—4* Ramp 1

c. Press **OK**. The following display appears:

3—41 Ramp 1 Ramp up Time
3.00s

d. Press **OK** again to highlight the bottom row; then use the ▲ (Up arrow) and ▼ (Down arrow) keys to select 10.00s. Press **OK** again to set the selected Ramp up Time.

e. Press ▼ (Down arrow key) once. The following display appears:

3—42 Ramp 1 Ramp Down Time
3.00s

f. Press **OK** again to highlight the bottom row; then use the ▲ (Up arrow) and ▼ (Down arrow) keys to select 10.00s. Press **OK** again to set the selected Ramp Down Time.

9. Set Limits:

a. Press the **Back** key until the following display appears:

2—** Brakes
3—** Reference/Ramps

b. Press ▼ (Down arrow key) once. The following display appears:

3—** Reference/Ramps
4—** Limits/Warnings

c. Press **OK**. The following display appears:

4—1* Motor Limits
4—4* Adj. Warning 2

d. Press **OK** again. The following display appears:

4—10 Motor Speed Direction
[2] Both Directions

e. Press ▼ (Down arrow key) once. The following display appears:

4—12 Motor Speed Low Limi...
0.0Hz

f. Press ▼ (Down arrow key) again. The following display appears:

4—14 Motor Speed High Limi...
65.0Hz

NOTE: Press **OK** to highlight the HZ value, and then use the ▲ (Up arrow) and ▼ (Down arrow) keys to enter the required values.

g. Press ▼ (Down arrow key) once. The following display appears:

4—18 Current Limit
110%

NOTE: Press **OK** to highlight the % value, and then use the ▲ (Up arrow) and ▼ (Down arrow) keys to enter the required value. See Tables 19-23 for the proper value for this parameter. Then press **OK** to set the selected value.

h. Press ▼ (Down arrow key) once. The following display appears:

4—19 Max Output Frequency
65.0Hz

NOTE: Press **OK** to highlight the HZ value, and then use the ▲ (Up arrow) and ▼ (Down arrow) keys to enter the required values.

10. Set Digital Inputs:

a. Press the **Back** key until the following display appears:

3—** Reference/Ramps
4—** Limits/Warnings

- b. Press **▼** (Down arrow key) once. The following display appears:

4—** Limits/Warnings
5—** Digital In/Out

- c. Press **OK**. The following display appears:

5—0* Digital I/O Mode
5—1* Digital Inputs

- d. Press **▼** (Down arrow key) once to move the highlight to the bottom row, then press **OK**. The following display appears:

5—10 Terminal 18 Digital In...
[8] Start

- e. Press **▼** (Down arrow key) again. The following display appears:

5—11 Terminal 19 Digital In...
[16] Preset ref bit 0

- f. Press **▼** (Down arrow key) again. The following display appears:

5—12 Terminal 27 Digital In...
[17] Preset ref bit 1

- g. Press **▼** (Down arrow key) again. The following display appears:

5—12 Terminal 29 Digital In...
[18] Preset ref bit 2

NOTE: By pressing **OK** the number in the bracket can be changed until the desired number appears. Press **OK** again to set the selected value.

11. Set Analog Inputs:

- a. Press the **Back** key until the following display appears:

4—** Limits/Warnings
5—** Digital In/Out

- b. Press **▼** (Down arrow key) until the following display appears:

5—** Digital In/Out
6—** Analog In/Out

- c. Press **OK**. The following display appears:

6—** Analog In/Out
6—1* Analog Input 53

- d. Press **▼** (Down arrow key) once to move the highlight to the bottom row, then press **OK**. The following display appears:

6—10 Terminal 53 Low Voltage
2V

- e. Press **▼** (Down arrow key) once to move the highlight to the bottom row, then press **OK**. The following display appears:

6—11 Terminal 53 High Voltage
[10V]

- f. Press **▼** (Down arrow key) once to move the highlight to the bottom row, then press **OK**. The following display appears:

6—14 Set Min Reference
[0 Hz]

- g. Press **▼** (Down arrow key) once to move the highlight to the bottom row, then press **OK**. The following display appears:

6—15 Set Max Reference
[60 Hz]

12. Set Reset Mode and RFI Filter:

- a. Press the **Back** key until the following display appears:

0—** Operation/Display
1—** Load and Motor

- b. Press **▼** (Down arrow key) until the following display appears:

13—** Smart Logic
14—** Special Functions

- c. Press **OK**. The following display appears:

14—0* Inverter Switching
14—1* Mains On/Off

- d. Press **▼** (Down arrow key) twice. The following display appears:

14—1* Mains On/Off
14—2* Reset Functions

- e. Press **OK**. The following display appears:

14—20 Reset Mode
[0] Manual reset

- f. Press **OK** to highlight the number in the bracket.

- g. Use the **▲** (Up arrow) and **▼** (Down arrow) keys to change the number to 3 for 2 automatic resets; then press **OK**. The display changes to:

14—20 Reset Mode
[3] Automatic reset x 3

- h. Press **▼** (Down arrow key) once. The following display appears:

24—21 Automatic Restart T...
10s

- i. Press **OK** to highlight the number of seconds and use the **▲** (Up arrow) and **▼** (Down arrow) keys to select 600 seconds. Press **OK** again to set the selected value.

- j. Press the **Back** key once. The following display appears:

14—1* Mains On/Off
14—2* Reset Functions

- k. Press **▼** (Down arrow key) twice. The following display appears:

14—4* Energy Optimizing
14—5* Environment

- l. Press **OK**. The following display appears:

14—50 RFI Filter
[1] On

- m. Press **OK** to highlight the number in the brackets and use the **▲** (Up arrow) and **▼** (Down arrow) keys to select 0. Press **OK** again to set the selected value.

13. Complete reprogramming: Press the **Auto On** key before disconnecting the VFD Remote Keypad from the variable frequency drive.

Table 19 — VFD Unit Parameters - 50LC Size 14

MOTOR OPTION	VOLTAGE	MOTOR P/N	VFD CARRIER P/N	VFD MFR P/N	REGIONAL SETTINGS	GRID TYPE	MOTOR POWER	MOTOR VOLTAGE	MOTOR FREQUENCY (Hz)	MOTOR CURRENT (MUST-HOLD AMPS)	MOTOR NOMINAL SPEED (RPM)
					0-03	0-06	1-20	1-22	1-29	1-24	1-25
STD	208/230V	HD58FE654	HK30WA371	131L9796	[1]	[102]	[10]	230	60	9.2	1735
	460V	HD58FE654	HK30WA377	131L9864		[122]	[10]	460		4.2	1735
	575V	HD58FE577	HK30WA383	131N0227		[132]	[11]	575		4.9	1710
MID	208/230V	HD60FK658	HK30WA372	131L9797		[102]	[13]	230		13.6	1745
	460V	HD60FK658	HK30WA379	131L9866		[122]	[13]	460		6.8	1745
	575V	HD60FE576	HK30WA387	134F0217		[132]	[13]	575		6.0	1745
HIGH	208/230V	HD60FK657	HK30WA373	131L9798		[102]	[14]	230		21.2	1760
	460V	HD60FK657	HK30WA380	131L9867		[122]	[14]	460		9.7	1760
	575V	HD60FL576	HK30WA384	131N0229		[132]	[14]	575		7.2	1745
ULTRA	208/230V	HD62FK654	HK30WA374	131L9799		[102]	[15]	230		28.0	1760
	460V	HD62FK654	HK30WA381	131L9868		[122]	[15]	460		13.7	1760
	575V	HD62FL576	HK30WA384	131N0229		[132]	[15]	575		8.9	1760

MOTOR OPTION	VOLTAGE	START DELAY (sec)	FLYING START	MIN SPEED FOR FUNCTION (Hz)	MOTOR THERMAL PROTECTION	PRESET REFERENCE							
		1-71	1-73	1-82	1-90	3-10 [0]	3-10 [1]	3-10 [2]	3-10 [3]	3-10 [4]	3-10 [5]	3-10 [6]	3-10 [7]
STD	208/230V	2.0	[1]	1.0	[4]	0%	53.43%	79.57%	100%	100%	0%	0%	0%
	460V												
	575V												
MID	208/230V												
	460V												
	575V												
HIGH	208/230V												
	460V												
	575V												
ULTRA	208/230V												
	460V												
	575V												

MOTOR OPTION	VOLTAGE	RAMP UP TIME (sec)	RAMP DOWN TIME (sec)	CURRENT LIMIT	TERMINAL 18 DIGITAL INPUT	TERMINAL 19 DIGITAL INPUT	TERMINAL 27 DIGITAL INPUT	TERMINAL 29 DIGITAL INPUT
		3-41	3-42	4-18	5-10	5-11	5-12	5-13
STD	208/230V	10.00	10.00	100%	[8]	[16]	[17]	[18]
	460V							
	575V							
MID	208/230V							
	460V							
	575V							
HIGH	208/230V							
	460V							
	575V							
ULTRA	208/230V							
	460V							
	575V							

MOTOR OPTION	VOLTAGE	TERMINAL 53 LOW VOLTAGE	TERMINAL 53 HIGH VOLTAGE	TERMINAL 53 LOW REFERENCE	TERMINAL 53 HIGH REFERENCE	RESET MODE	AUTO. RESTART TIME (S)	RFI FILTER
		6-10	6-11	6-14	6-15	14-20	14-21	14-50
STD	208/230V	2	[10]	0	[60]	[3]	600	[0]
	460V							
	575V							
MID	208/230V							
	460V							
	575V							
HIGH	208/230V							
	460V							
	575V							
ULTRA	208/230V							
	460V							
	575V							

Table 20 — VFD Unit Parameters - 50LC Size 17

MOTOR OPTION	VOLTAGE	MOTOR P/N	VFD CARRIER P/N	VFD MFR P/N	REGIONAL SETTINGS	GRID TYPE	MOTOR POWER	MOTOR VOLTAGE	MOTOR FREQUENCY (Hz)	MOTOR CURRENT (MUST-HOLD AMPS)	MOTOR NOMINAL SPEED (RPM)
					0-03	0-06	1-20	1-22	1-29	1-24	1-25
STD	208/230V	HD58FE654	HK30WA371	131L9796	[1]	[102]	[10]	230	60	9.2	1735
	460V	HD58FE654	HK30WA377	131L9864	[1]	[122]	[10]	460		4.2	1735
	575V	HD58FE577	HK30WA383	131N0227	[1]	[132]	[11]	575		4.9	1710
MID	208/230V	HD60FK657	HK30WA373	131L9798	[1]	[102]	[14]	230		21.2	1760
	460V	HD60FK657	HK30WA380	131L9867	[1]	[122]	[14]	460		9.7	1760
	575V	HD60FL576	HK30WA384	131N0229	[1]	[132]	[14]	575		7.2	1745
HIGH	208/230V	HD62FK654	HK30WA374	131L9799	[1]	[102]	[15]	230		28.0	1760
	460V	HD62FK654	HK30WA381	131L9868	[1]	[122]	[15]	460		13.7	1760
	575V	HD62FL576	HK30WA384	131N0229	[1]	[132]	[15]	575		8.9	1750
ULTRA	208/230V	HD64FK654	HK30WA375	131L9800	[1]	[102]	[16]	230		37.3	1755
	460V	HD64FK654	HK30WA386	131L9869	[1]	[122]	[16]	460		16.9	1755
	575V	HD64FL576	HK30WA388	131N0233	[1]	[132]	[16]	575		12.6	1755

MOTOR OPTION	VOLTAGE	START DELAY (sec)	FLYING START	MIN SPEED FOR FUNCTION (Hz)	MOTOR THERMAL PROTECTION	PRESET REFERENCE							
		1-71	1-73	1-82	1-90	3-10 [0]	3-10 [1]	3-10 [2]	3-10 [3]	3-10 [4]	3-10 [5]	3-10 [6]	3-10 [7]
STD	208/230V	2.0	[1]	1.0	[4]	0%	56.64%	82.40%	100%	100%	0%	0%	0%
	460V												
	575V												
MID	208/230V												
	460V												
	575V												
HIGH	208/230V												
	460V												
	575V												
ULTRA	208/230V												
	460V												
	575V												

MOTOR OPTION	VOLTAGE	RAMP UP TIME (sec)	RAMP DOWN TIME (sec)	CURRENT LIMIT	TERMINAL 18 DIGITAL INPUT	TERMINAL 19 DIGITAL INPUT	TERMINAL 27 DIGITAL INPUT	TERMINAL 29 DIGITAL INPUT
		3-41	3-42	4-18	5-10	5-11	5-12	5-13
STD	208/230V	10.00	10.00	100%	[8]	[16]	[17]	[18]
	460V							
	575V							
MID	208/230V							
	460V							
	575V							
HIGH	208/230V							
	460V							
	575V							
ULTRA	208/230V							
	460V							
	575V							

MOTOR OPTION	VOLTAGE	TERMINAL 53 LOW VOLTAGE	TERMINAL 53 HIGH VOLTAGE	TERMINAL 53 LOW REFERENCE	TERMINAL 53 HIGH REFERENCE	RESET MODE	AUTO. RESTART TIME (s)	RFI FILTER
		6-10	6-11	6-14	6-15	14-20	14-21	14-50
STD	208/230V	2	[10]	0	[60]	[3]	600	[0]
	460V							
	575V							
MID	208/230V							
	460V							
	575V							
HIGH	208/230V							
	460V							
	575V							
ULTRA	208/230V							
	460V							
	575V							

Table 21 — VFD Unit Parameters - 50LC Size 20

MOTOR OPTION	VOLTAGE	MOTOR P/N	VFD CARRIER P/N	VFD MFR P/N	REGIONAL SETTINGS	GRID TYPE	MOTOR POWER	MOTOR VOLTAGE	MOTOR FREQUENCY (Hz)	MOTOR CURRENT (MUST-HOLD AMPS)	MOTOR NOMINAL SPEED (RPM)
					0-03	0-06	1-20	1-22	1-29	1-24	1-25
STD	208/230V	HD60FE656	HK30WA372	131L9797	[1]	[102]	[11]	230	60	11.7	1750
	460V	HD60FE656	HK30WA378	131L9865		[122]	[11]	460		5.4	1750
	575V	HD58FE577	HK30WA383	131N0227		[132]	[11]	575		4.9	1710
MID	208/230V	HD60FK657	HK30WA373	131L9798		[102]	[14]	230		21.2	1760
	460V	HD60FK657	HK30WA380	131L9867		[122]	[14]	460		9.7	1760
	575V	HD60FL576	HK30WA384	131N0229		[132]	[14]	575		7.2	1745
HIGH	208/230V	HD62FK654	HK30WA374	131L9799		[102]	[15]	230		28.0	1760
	460V	HD62FK654	HK30WA381	131L9868		[122]	[15]	460		13.7	1760
	575V	HD62FL576	HK30WA384	131N0229		[132]	[15]	575		8.9	1750
ULTRA	208/230V	HD64FK654	HK30WA375	131L9800		[102]	[16]	230		37.3	1755
	460V	HD64FK654	HK30WA386	131L9869		[122]	[16]	460		16.9	1755
	575V	HD64FL576	HK30WA388	131N0233		[132]	[16]	575		12.6	1755

MOTOR OPTION	VOLTAGE	START DELAY (sec)	FLYING START	MIN SPEED FOR FUNCTION (Hz)	MOTOR THERMAL PROTECTION	PRESET REFERENCE							
		1-71	1-73	1-82	1-90	3-10 [0]	3-10 [1]	3-10 [2]	3-10 [3]	3-10 [4]	3-10 [5]	3-10 [6]	3-10 [7]
STD	208/230V	2.0	[1]	1.0	[4]	0%	52.57%	61.63%	100%	100%	0%	0%	0%
	460V												
	575V												
MID	208/230V												
	460V												
	575V												
HIGH	208/230V												
	460V												
	575V												
ULTRA	208/230V												
	460V												
	575V												

MOTOR OPTION	VOLTAGE	RAMP UP TIME (sec)	RAMP DOWN TIME (sec)	CURRENT LIMIT	TERMINAL 18 DIGITAL INPUT	TERMINAL 19 DIGITAL INPUT	TERMINAL 27 DIGITAL INPUT	TERMINAL 29 DIGITAL INPUT
		3-41	3-42	4-18	5-10	5-11	5-12	5-13
STD	208/230V	10.00	10.00	100%	[8]	[16]	[17]	[18]
	460V							
	575V							
MID	208/230V							
	460V							
	575V							
HIGH	208/230V							
	460V							
	575V							
ULTRA	208/230V							
	460V							
	575V							

MOTOR OPTION	VOLTAGE	TERMINAL 53 LOW VOLTAGE	TERMINAL 53 HIGH VOLTAGE	TERMINAL 53 LOW REFERENCE	TERMINAL 53 HIGH REFERENCE	RESET MODE	AUTO. RESTART TIME (s)	RFI FILTER
		6-10	6-11	6-14	6-15	14-20	14-21	14-50
STD	208/230V	2	[10]	0	[60]	[3]	600	[0]
	460V							
	575V							
MID	208/230V							
	460V							
	575V							
HIGH	208/230V							
	460V							
	575V							
ULTRA	208/230V							
	460V							
	575V							

Table 22 — VFD Unit Parameters - 50LC Size 24

MOTOR OPTION	VOLTAGE	MOTOR P/N	VFD CARRIER P/N	VFD MFR P/N	REGIONAL SETTINGS	GRID TYPE	MOTOR POWER	MOTOR VOLTAGE	MOTOR FREQUENCY (Hz)	MOTOR CURRENT (MUST-HOLD AMPS)	MOTOR NOMINAL SPEED (RPM)
					0-03	0-06	1-20	1-22	1-29	1-24	1-25
STD	208/230V	HD60FK657	HK30WA373	131L9798	[1]	[102]	[14]	230	60	21.2	1760
	460V	HD60FK657	HK30WA380	131L9867		[122]	[14]	460		9.7	1760
	575V	HD60FL576	HK30WA384	131N0229		[132]	[14]	575		7.2	1745
MID	208/230V	HD60FK657	HK30WA373	131L9798		[102]	[14]	230		21.2	1760
	460V	HD60FK657	HK30WA380	131L9867		[122]	[14]	460		9.7	1760
	575V	HD60FL576	HK30WA384	131N0229		[132]	[14]	575		7.2	1745
HIGH	208/230V	HD62FK654	HK30WA374	131L9799		[102]	[15]	230		28.0	1760
	460V	HD62FK654	HK30WA381	131L9868		[122]	[15]	460		13.7	1760
	575V	HD62FL576	HK30WA384	131N0229		[132]	[15]	575		8.9	1750
ULTRA	208/230V	HD64FK654	HK30WA375	131L9800		[102]	[16]	230		37.3	1755
	460V	HD64FK654	HK30WA386	131L9869		[122]	[16]	460		16.9	1755
	575V	HD64FL576	HK30WA388	131N0233		[132]	[16]	575		12.6	1755

MOTOR OPTION	VOLTAGE	START DELAY (sec)	FLYING START	MIN SPEED FOR FUNCTION (Hz)	MOTOR THERMAL PROTECTION	PRESET REFERENCE							
		1-71	1-73	1-82	1-90	3-10 [0]	3-10 [1]	3-10 [2]	3-10 [3]	3-10 [4]	3-10 [5]	3-10 [6]	3-10 [7]
STD	208/230V	2.0	[1]	1.0	[4]	0%	52.33%	64.48%	100%	100%	0%	0%	0%
	460V												
	575V												
MID	208/230V												
	460V												
	575V												
HIGH	208/230V												
	460V												
	575V												
ULTRA	208/230V												
	460V												
	575V												

MOTOR OPTION	VOLTAGE	RAMP UP TIME (sec)	RAMP DOWN TIME (sec)	CURRENT LIMIT	TERMINAL 18 DIGITAL INPUT	TERMINAL 19 DIGITAL INPUT	TERMINAL 27 DIGITAL INPUT	TERMINAL 29 DIGITAL INPUT
		3-41	3-42	4-18	5-10	5-11	5-12	5-13
STD	208/230V	10.00	10.00	100%	[8]	[16]	[17]	[18]
	460V							
	575V							
MID	208/230V							
	460V							
	575V							
HIGH	208/230V							
	460V							
	575V							
ULTRA	208/230V							
	460V							
	575V							

MOTOR OPTION	VOLTAGE	TERMINAL 53 LOW VOLTAGE	TERMINAL 53 HIGH VOLTAGE	TERMINAL 53 LOW REFERENCE	TERMINAL 53 HIGH REFERENCE	RESET MODE	AUTO. RESTART TIME (s)	RFI FILTER
		6-10	6-11	6-14	6-15	14-20	14-21	14-50
STD	208/230V	2	[10]	0	[60]	[3]	600	[0]
	460V							
	575V							
MID	208/230V							
	460V							
	575V							
HIGH	208/230V							
	460V							
	575V							
ULTRA	208/230V							
	460V							
	575V							

Table 23 — VFD Unit Parameters - 50LC Size 26

MOTOR OPTION	VOLTAGE	MOTOR P/N	VFD CARRIER P/N	VFD MFR P/N	REGIONAL SETTINGS	GRID TYPE	MOTOR POWER	MOTOR VOLTAGE	MOTOR FREQUENCY (Hz)	MOTOR CURRENT (MUST-HOLD AMPS)	MOTOR NOMINAL SPEED (RPM)
					0-03	0-06	1-20	1-22	1-29	1-24	1-25
STD	208/230V	HD60FK657	HK30WA373	131L9798	[1]	[102]	[14]	230	60	21.2	1760
	460V	HD60FK657	HK30WA380	131L9867		[122]	[14]	460		9.7	1760
	575V	HD60FL576	HK30WA384	131N0229		[132]	[14]	575		7.2	1745
MID	208/230V	HD62FK654	HK30WA374	131L9799		[102]	[15]	230		28.0	1760
	460V	HD62FK654	HK30WA381	131L9868		[122]	[15]	460		13.7	1760
	575V	HD62FL576	HK30WA384	131N0229		[132]	[15]	575		8.9	1750
HIGH	208/230V	HD64FK654	HK30WA375	131L9800		[102]	[16]	230		37.3	1755
	460V	HD64FK654	HK30WA386	131L9869		[122]	[16]	460		16.9	1755
	575V	HD64FL576	HK30WA388	131N0233		[132]	[16]	575		12.6	1755

MOTOR OPTION	VOLTAGE	START DELAY (sec)	FLYING START	MIN SPEED FOR FUNCTION (Hz)	MOTOR THERMAL PROTECTION	PRESET REFERENCE							
		1-71	1-73	1-82	1-90	3-10 [0]	3-10 [1]	3-10 [2]	3-10 [3]	3-10 [4]	3-10 [5]	3-10 [6]	3-10 [7]
STD	208/230V	2.0	[1]	1.0	[4]	0%	60.00%	72.00%	100%	100%	0%	0%	0%
	460V												
	575V												
MID	208/230V												
	460V												
	575V												
HIGH	208/230V												
	460V												
	575V												

MOTOR OPTION	VOLTAGE	RAMP UP TIME (sec)	RAMP DOWN TIME (sec)	CURRENT LIMIT	TERMINAL 18 DIGITAL INPUT	TERMINAL 19 DIGITAL INPUT	TERMINAL 27 DIGITAL INPUT	TERMINAL 29 DIGITAL INPUT
		3-41	3-42	4-18	5-10	5-11	5-12	5-13
STD	208/230V	10.00	10.00	100%	[8]	[16]	[17]	[18]
	460V							
	575V							
MID	208/230V							
	460V							
	575V							
HIGH	208/230V							
	460V							
	575V							

MOTOR OPTION	VOLTAGE	TERMINAL 53 LOW VOLTAGE	TERMINAL 53 HIGH VOLTAGE	TERMINAL 53 LOW REFERENCE	TERMINAL 53 HIGH REFERENCE	RESET MODE	AUTO. RESTART TIME (s)	RFI FILTER
		6-10	6-11	6-14	6-15	14-20	14-21	14-50
STD	208/230V	2	[10]	0	[60]	[3]	600	[0]
	460V							
	575V							
MID	208/230V							
	460V							
	575V							
HIGH	208/230V							
	460V							
	575V							

Smoke Detectors

Smoke detectors are available as factory-installed options on 50LC 14-26 models. Smoke detectors may be specified for supply air only, for return air without or with economizer, or in combination of supply air and return air. The unit is factory-configured for immediate smoke detector shutdown operation; additional wiring or modifications to unit's Integrated Staging Control (ISC) board may be necessary to complete the unit and smoke detector configuration to meet project requirements.

RETURN AIR SENSOR TUBE INSTALLATION

The return air sampling tube is shipped in the unit's supply fan section, attached to the blower housing (see Fig. 88). Its operating location is in the return air section of the unit (see Fig. 89, unit without economizer, or Fig. 90, unit with economizer), inserted into the return air sensor module housing which protrudes through the back of the control box.

To install the return air sensor sampling tube:

1. Remove the tube from its shipping location.
2. Open the unit end to access the return air sensor (located on right-hand partition)
3. Orient the tube's sampling holes into the return air flow direction. For vertical application, position the sampling holes on the bottom of the tube, facing into the bottom return duct opening. For horizontal application, position the sampling holes on the side of the tube, facing the unit's end panel.
4. Insert the sampling tube into the return air sensor module until the tube snaps into position.
5. Replace end panel or outside air hood.

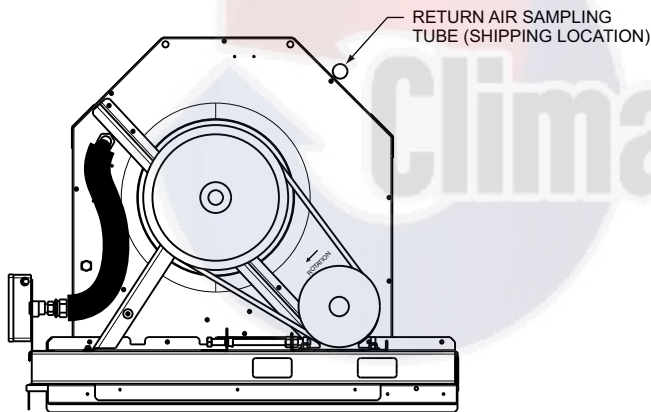

Fig. 88 — Typical Supply Air Smoke Detector Sensor Location

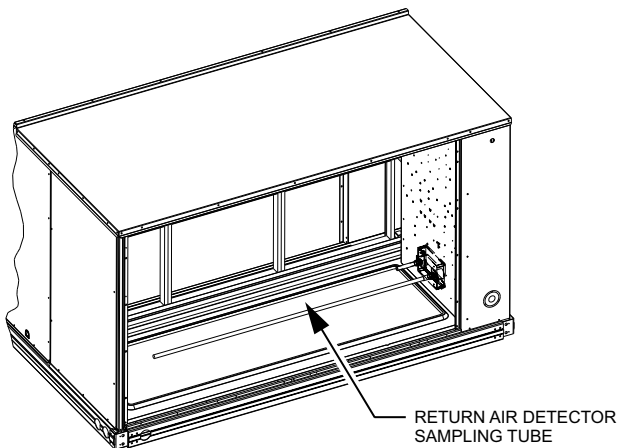

Fig. 89 — Return Air Sampling Tube Location in Unit without Economizer

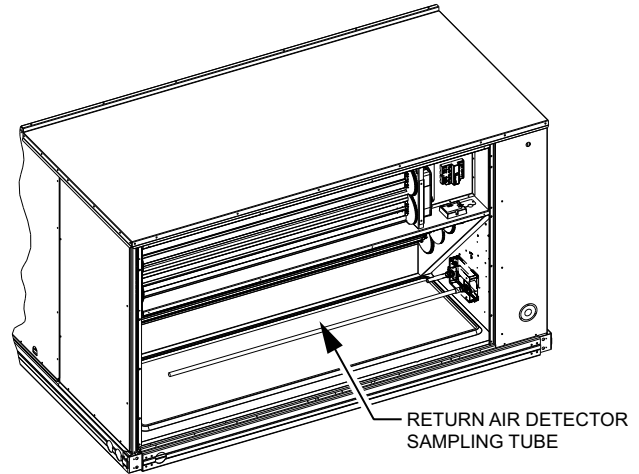

Fig. 90 — Return Air Sampling Tube Location in Unit with Economizer

SMOKE DETECTOR TEST MAGNET

Locate the magnet; it is shipped in the control box area.

ADDITIONAL APPLICATION DATA

Refer to *Factory Installed Smoke Detectors for Small and Medium Rooftop Units 2 to 25 Tons* for discussions on additional control features of these smoke detectors including multiple unit coordination.

Step 13 — Install Accessories

Available accessories include:

- Roof Curb (must be installed before unit)
- Electric heaters
- EconoMiSer® X (with control)
- Power Exhaust
- Outdoor enthalpy sensor
- Differential enthalpy sensor
- CO₂ sensor
- Temperature and Humidity sensors
- Louvered hail guard
- Phase monitor control

Refer to separate installation instructions for information on installing these accessories. See 50LC 14-26 Price Pages for a complete list of field-installed accessories.

Step 14 — Check Belt Tension

Measure the belt span length as shown in Fig. 91. Calculate the required deflection by multiplying the belt span length by $\frac{1}{64}$. For example, if the belt span length is 32 inches:

$$32 \times \frac{1}{64} = \frac{1}{2} \text{ inch deflection.}$$

BELT FORCE: DEFLECTION METHOD

Check the belt tension with a spring-force belt force deflection gage.

1. Place a straightedge along the belt between the two pulleys. Measure the distance between the motor shaft and the blower shaft.
2. Set the tension gage to the desired tension (see Table 1 in Fig. 91). Place the large O-ring at that point.
3. Press the tension checker downward on the belt until the large O-ring is at the bottom of the straightedge.
4. Adjust the belt tension as needed.

Adjust belt tension by loosening the motor mounting plate front bolts and rear bolt (see Fig. 92) and sliding the plate towards the fan (to reduce tension) or away from the fan (to increase tension). Ensure the blower shaft and motor shaft are parallel to each other (pulleys aligned). Tighten all bolts securely when finished.

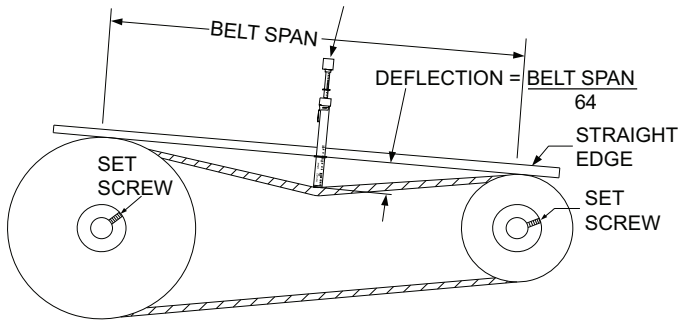

TORQUE ALL SHEAVE SET SCREWS TO 110-130 in. lbs

Table 1

BELT CROSS SECTION	SMALLEST SHEAVE DIAMETER	BELT DEFLECTION FORCE (LBS)			
		UNNOTCHED BELTS		NOTCHED BELTS	
		USED	NEW	USED	NEW
A, AX	3.0-3.6	3.7	5.5	4.1	6.1
	3.8-4.8	4.5	6.8	5.0	7.4
	5.0-7.0	5.4	8.0	5.7	8.4
B, BX	3.4-4.2	—	—	4.9	7.2
	4.4-5.6	5.3	7.9	7.1	10.5
	5.8-8.6	6.3	9.4	8.5	12.6

Table 2

BELT CONDITION	TENSION FORCE IN BELT (LBS)
NEW	100
USED	80

Fig. 91 — V-Belt Force Label

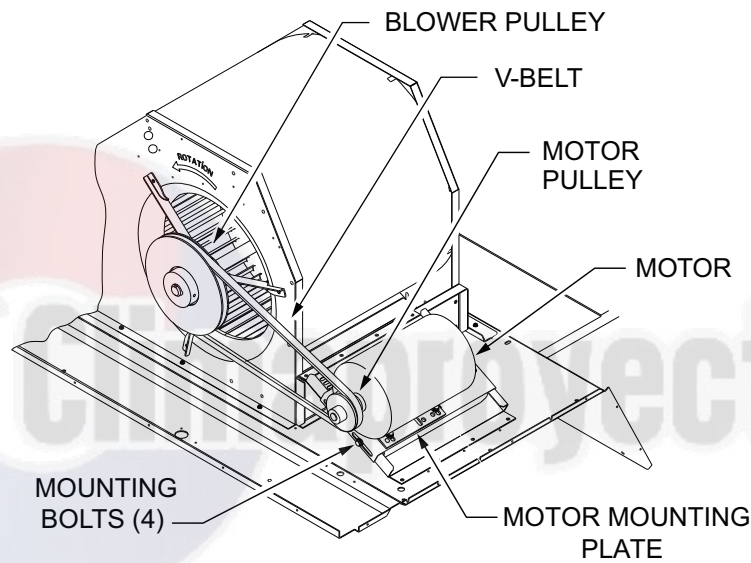

Fig. 92 — Belt Drive Motor Mounting

Pre-Start and Start-Up

This completes the mechanical installation of the unit. Refer to the unit's Service and Maintenance manual for detailed pre-start and start-up instructions.







**START-UP CHECKLIST FOR 50LC14-26 SINGLE PACKAGE ROOFTOP
COOLING ONLY
(REMOVE AND USE FOR JOB FILE)**

NOTE: To avoid injury to personnel and damage to equipment or property when completing the procedures listed in this start-up checklist, use good judgment, follow safe practices, and adhere to the safety considerations/information as outlined in preceding sections of this Installation Instruction document.

I. PRELIMINARY INFORMATION

MODEL NO _____
JOB NAME _____
SERIAL NO _____
ADDRESS _____
START-UP DATE _____
TECHNICIAN NAME _____
ADDITIONAL ACCESSORIES _____

II. PRE-START-UP

Verify that all packaging materials have been removed from unit (Y/N) _____
Verify installation of outdoor air hood (Y/N) _____
Verify that condensate connection is installed per instructions (Y/N) _____
Verify that all electrical connections and terminals are tight (Y/N) _____
Check that indoor-air filters are clean and in place (Y/N) _____
Check that outdoor air inlet screens are in place (Y/N) _____
Verify that unit is level (Y/N) _____
Check fan wheels and propeller for location in housing/orifice and verify setscrew is tight (Y/N) _____
Verify that fan sheaves are aligned and belts are properly tensioned (Y/N) _____
Verify that scroll compressors are rotating in the correct direction (Y/N) _____
Verify installation of thermostat (Y/N) _____

III. START-UP

ELECTRICAL

Supply Voltage	L1-L2 _____	L2-L3 _____	L3-L1 _____
Compressor Amps 1	L1 _____	L2 _____	L3 _____
Compressor Amps 2	L1 _____	L2 _____	L3 _____
Supply Fan Amps	L1 _____	L2 _____	L3 _____

TEMPERATURES

Outdoor-air Temperature _____ °F DB (Dry Bulb)
Return-air Temperature _____ °F DB _____ °F Wb (Wet Bulb)
Cooling Supply Air Temperature _____ °F

PRESSURES

Refrigerant Suction CIRCUIT A _____ PSIG
 CIRCUIT B _____ PSIG
Refrigerant Discharge CIRCUIT A _____ PSIG
 CIRCUIT B _____ PSIG
Verify Refrigerant Charge using Charging Charts (Y/N) _____

GENERAL

Economizer minimum vent and changeover settings to job requirements (if equipped) (Y/N) _____
Verify smoke detector unit shutdown by utilizing magnet test (Y/N) _____

IV. HUMIDI-MIZER® START-UP

NOTE: Units equipped with either SystemVu™ or RTU Open controls have Service Test menus or modes that can assist with the Humidi-MiZer System Start-Up function and provide the means to make the observations listed for this start-up.

STEPS

1. Check CTB for jumper 5, 6, 7 (Jumper 5, 6, 7 must be cut and open) (Y/N) _____
2. Open humidistat contacts (Y/N) _____
3. Start unit In cooling (Close Y1) (Y/N) _____

OBSERVE AND RECORD

- A. Suction pressure _____ PSIG
 - B. Discharge pressure _____ PSIG
 - C. Entering air temperature _____ ° F
 - D. Liquid line temperature at outlet or reheat coil _____ ° F
 - E. Confirm correct rotation for compressor (Y/N) _____
 - F. Check for correct ramp-up of outdoor fan motor as condenser coil warms (Y/N) _____
4. Check unit charge per charging chart (Y/N) _____
(Jumper 32L Motormaster® temperature sensor during this check. Remove jumper when complete.)
 5. Switch unit to high-latent mode (sub-cooler) by closing humidistat with Y1 closed (Y/N) _____

OBSERVE

- A. Reduction in suction pressure (5 to 7 psi expected) (Y/N) _____
 - B. Discharge pressure unchanged (Y/N) _____
 - C. Liquid temperature drops to 50 to 55°F range (Y/N) _____
 - D. LSV solenoid energized (valve closes) (Y/N) _____
6. Switch unit to dehumid (reheat) by opening Y1 (Y/N) _____

OBSERVE

- A. Suction pressure increases to normal cooling level (Y/N) _____
 - B. Discharge pressure decreases (35 to 50 psi) (Limited by Motormaster control) (Y/N) _____
 - C. Liquid temperature returns to normal cooling level (Y/N) _____
 - D. LSV solenoid energized (valve closes) (Y/N) _____
 - E. DSV solenoid energized, valve opens (Y/N) _____
7. With unit in dehumid mode close W1 compressor and outdoor fan stop; LSV and DSV solenoids de-energized (Y/N) _____
 8. Open W1 restore unit to dehumid mode (Y/N) _____
 9. Open humidistat input compressor and outdoor fan stop; LSV and DSV solenoids de-energized (Y/N) _____
 10. Restore set-points for thermostat and humidistat (Y/N) _____

REPEAT PROCESS FOR 2 COMPRESSOR SYSTEMS.

CUT ALONG DOTTED LINE

CUT ALONG DOTTED LINE