

ELECTRIC AIR HANDLERS FOR 7½ & 10-TON SPLIT SYSTEMS



■ Contents

Nomenclature	2
Product Specifications.....	3
Airflow Data	4
Temperature Rise	6
Electrical Heater Kits.....	7
Dimensions.....	8
Wiring Diagrams	9
Accessories	11

■ Standard Features

- TXV Control; Units have two (2) thermal expansion valves
- DAX units feature two 5-speed direct-drive motors
- Copper tube/aluminum fin coils
- AHRI Certified; ETL Listed

■ Cabinet Features

- Heavy-gauge, reinforced, galvanized-steel cabinet
- Fully insulated with fiberglass blanket
- Horizontal and vertical condensate pans
- Built-in filter rack (2" filter included)
- Entry on top of panel for both low and high voltage
- Removable access panels make servicing of unit faster and easier



* Complete warranty details available from your local dealer or at www.daikincomfort.com.

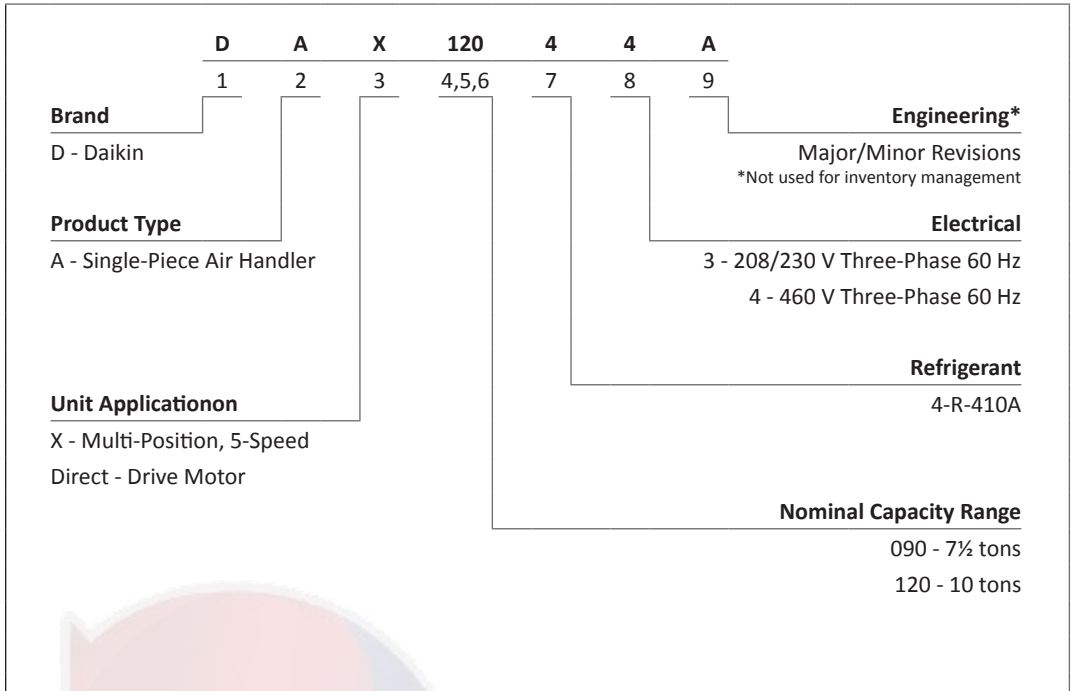

	DAX09043**	DAX09044**	DAX12043**	DAX12044**
TOTAL CAPACITIES				
Cooling (BTU/h)	90,000	90,000	120,000	120,000
Heating (kW)	15, 20, 30	15, 20, 30	15, 20, 30	15, 20, 30
CFM	3,000	3,000	4,000	4,000
ELECTRICAL DATA				
Voltage-Hz-Phase	208/240-60-3	460-60-3	208/240-60-3	460-60-3
Voltage Range	197 - 253	414-506	197 - 253	414-506
FLA (Total)	13.8	4.6	13.8	4.6
Minimum Circuit Ampacity	15.5/15.5	5.2	15.5/15.5	5.2
BLOWER MOTOR				
Type	Direct Drive	Direct Drive	Direct Drive	Direct Drive
Horse Power	1	1	1	1
Voltage-Hz-Phase	208/240-60-3	460-60-3	208/240-60-3	460-60-3
FLA/ LRA	6.9/47.7	2.3/23.9	6.9/47.7	2.3/23.9
BLOWER & CONTROLS				
Wheel Dia. & Width (Qty.)	11 x 10 (2)	11 x 10 (2)	11 x 10 (2)	11 x 10 (2)
Nominal Airflow (Ft./Min.)	3,000	3,000	4,000	4,000
Transformer	Standard	Standard	Standard	Standard
Blower Relay	Standard	Standard	Standard	Standard
FILTER, COIL & REFRIGERANT				
Disposable Filter Size / Qty	16"x20"x2"/ 2 20"x20"x2"/ 2	16"x20"x2"/ 2 20"x20"x2"/ 2	16"x20"x2"/ 2 20"x20"x2"/ 2	16"x20"x2"/ 2 20"x20"x2"/ 2
Coil Area (sq. ft.)	10	10	10	10
FPI - Rows	14 - 4	14 - 4	14 - 4	14 - 4
Expansion Valve Qty.	2	2	2	2
Refrigerant	R-410A	R-410A	R-410A	R-410A
Liquid Connection (Qty.)	3/8" (2) *	3/8" (2) *	3/8" (2) *	3/8" (2) *
Suction Connection (Qty.)	1 1/8" (2)	1 1/8" (2)	1 1/8" (2) *	1 1/8" (2) *
Condensate Drain	3/4 FPT	3/4 FPT	3/4 FPT	3/4 FPT
SHIP WEIGHT (LBS)	430	430	430	430

* For two refrigerant lines

BLOWER PERFORMANCE TABLES • 7.5 Ton LC Indoor Split System • Models: DAX0904

*UP-FLOW				
SPEED TAP	ESP (IN H ₂ O)	SCFM	RPM	BHP
T1	0.1	2124	558	0.06
	0.2	1635	566	0.06
	0.3	1445	611	0.07
	0.4	1270	662	0.08
	0.5	1079	715	0.08
	0.6	855	765	0.09
	0.7			
	0.8			
T2	0.1	3069	727	0.21
	0.2	2953	761	0.22
	0.3	2843	794	0.23
	0.4	2731	829	0.24
	0.5	2594	869	0.25
	0.6	2453	909	0.26
	0.7	2310	947	0.27
	0.8	2189	981	0.28
T3	0.1	3069	727	0.21
	0.2	2953	761	0.22
	0.3	2843	794	0.23
	0.4	2731	829	0.24
	0.5	2594	869	0.25
	0.6	2453	909	0.26
	0.7	2310	947	0.27
	0.8	2189	981	0.28
T4	0.1	3456	794	0.29
	0.2	3343	825	0.30
	0.3	3242	856	0.31
	0.4	3137	886	0.32
	0.5	3024	919	0.33
	0.6	2907	953	0.34
	0.7	2780	988	0.36
	0.8	2659	1023	0.37
T5	0.1	3785	850	0.47
	0.2	3688	875	0.48
	0.3	3590	904	0.50
	0.4	3500	931	0.51
	0.5	3407	958	0.53
	0.6	3310	987	0.54
	0.7	3176	1021	0.56
	0.8	3050	1058	0.58

*HORIZONTAL FLOW				
SPEED TAP	ESP	SCFM	RPM	BHP
T1	0.1	2125	552	0.06
	0.2	1583	553	0.06
	0.3	1132	591	0.07
	0.4	911	653	0.07
	0.5			
	0.6			
	0.7			
	0.8			
T2	0.1	3125	708	0.20
	0.2	3006	746	0.21
	0.3	2910	778	0.22
	0.4	2805	810	0.23
	0.5	2690	844	0.24
	0.6	2553	882	0.25
	0.7	2414	919	0.26
	0.8	2295	953	0.27
T3	0.1	3125	708	0.20
	0.2	3006	746	0.21
	0.3	2910	778	0.22
	0.4	2805	810	0.23
	0.5	2690	844	0.24
	0.6	2553	882	0.25
	0.7	2414	919	0.26
	0.8	2295	953	0.27
T4	0.1	3509	776	0.28
	0.2	3395	809	0.29
	0.3	3300	839	0.30
	0.4	3203	869	0.31
	0.5	3102	899	0.33
	0.6	2990	931	0.34
	0.7	2876	963	0.35
	0.8	2765	995	0.36
T5	0.1	3869	838	0.46
	0.2	3757	867	0.48
	0.3	3662	896	0.49
	0.4	3559	924	0.51
	0.5	3470	951	0.53
	0.6	3377	979	0.54
	0.7	3282	1007	0.56
	0.8	3163	1040	0.57

*Above table is for dry coil with filter in place. SCFM correction for wet coil results in 4%reduction.

NOTES:

- Any adjustment made to the blower should not cause the motor to draw more than the motors rated RLA.
- Applications that exceed the above could require a larger motor.

BLOWER PERFORMANCE TABLES • 10Ton LC Indoor Split System • Models: DAX0904

UP FLOW				
SPEED TAP	ESP (IN H ₂ O)	SCFM	RPM	BHP
T1	0.1	2527	622	0.17
	0.2	2396	663	0.18
	0.3	2239	711	0.19
	0.4	2086	754	0.20
	0.5	1936	795	0.21
	0.6	1804	833	0.22
	0.7	1672	870	0.23
	0.8	1507	903	0.24
T2	0.1	4020	894	0.55
	0.2	3913	921	0.57
	0.3	3815	948	0.59
	0.4	3728	974	0.60
	0.5	3621	1000	0.62
	0.6	3533	1026	0.63
	0.7	3441	1055	0.65
	0.8	3328	1088	0.67
T3	0.1	3785	850	0.47
	0.2	3688	875	0.48
	0.3	3590	904	0.50
	0.4	3500	931	0.51
	0.5	3407	958	0.53
	0.6	3310	987	0.54
	0.7	3176	1021	0.56
	0.8	3050	1058	0.58
T4	0.1	4488	975	0.56
	0.2	4385	997	0.57
	0.3	4291	1021	0.58
	0.4	4210	1046	0.60
	0.5	4130	1069	0.61
	0.6	4050	1092	0.62
	0.7	3972	1115	0.64
	0.8	3893	1138	0.65
T5	0.1	4601	1005	0.81
	0.2	4501	1031	0.83
	0.3	4408	1055	0.85
	0.4	4329	1078	0.87
	0.5	4252	1102	0.89
	0.6	4175	1124	0.91
	0.7	4099	1148	0.93
	0.8	4022	1171	0.95

HORIZONTAL FLOW				
SPEED TAP	ESP	SCFM	RPM	BHP
T1	0.1	2576	618	0.16
	0.2	2460	661	0.18
	0.3	2328	702	0.19
	0.4	2173	747	0.20
	0.5	2016	789	0.21
	0.6	1867	832	0.22
	0.7	1717	875	0.23
	0.8	1514	920	0.25
T2	0.1	4094	879	0.54
	0.2	3978	906	0.56
	0.3	3888	932	0.58
	0.4	3800	959	0.59
	0.5	3728	985	0.61
	0.6	3640	1010	0.63
	0.7	3553	1035	0.64
	0.8	3460	1062	0.66
T3	0.1	3869	838	0.46
	0.2	3757	867	0.48
	0.3	3662	896	0.49
	0.4	3559	924	0.51
	0.5	3470	951	0.53
	0.6	3377	979	0.54
	0.7	3282	1007	0.56
	0.8	3163	1040	0.57
T4	0.1	4519	956	0.55
	0.2	4416	982	0.56
	0.3	4324	1006	0.57
	0.4	4245	1031	0.59
	0.5	4164	1056	0.60
	0.6	4087	1079	0.62
	0.7	4008	1103	0.63
	0.8	3934	1126	0.64
T5	0.1	4723	983	0.80
	0.2	4623	1006	0.81
	0.3	4536	1031	0.83
	0.4	4453	1055	0.85
	0.5	4373	1079	0.87
	0.6	4294	1103	0.89
	0.7	4219	1125	0.91
	0.8	4143	1148	0.93

*Above table is for dry coil with filter in place. SCFM correction for wet coil results in 4% reduction.

TEMPERATURE RISE RANGE

MODEL	HEAT KIT kW	CFM	SUPPLY VOLTAGE		
			208	240	480
DAX0904**	15	2800	12	16	16
		2900	12	16	16
		3000	11	15	15
		3100	11	15	15
		3200	10	14	14
	20	2800	16	22	22
		2900	16	21	21
		3000	16	21	21
		3100	16	20	20
		3200	15	20	20
	30	2800	24	32	32
		2900	23	31	31
		3000	23	30	30
		3100	21	29	29
		3200	21	29	29

MODEL	HEAT KIT kW	CFM	SUPPLY VOLTAGE		
			208	240	480
DAX1204**	15	3800	9	12	12
		3900	9	12	12
		4000	9	12	12
		4100	9	12	12
		4200	8	11	11
	20	3800	12	17	17
		3900	12	16	16
		4000	12	16	16
		4100	12	15	15
		4200	11	15	15
	30	3800	19	25	25
		3900	18	24	24
		4000	18	24	24
		4100	17	23	23
		4200	17	23	23

NOTES:

1. Above table are calculated with both stages of electric heat engaged (2-stage heat systems). Divide the temperature rise from the table by 2 for 1st stage operation for systems using staged electric heat.
2. Temperature rise data are in Degrees Fahrenheit.

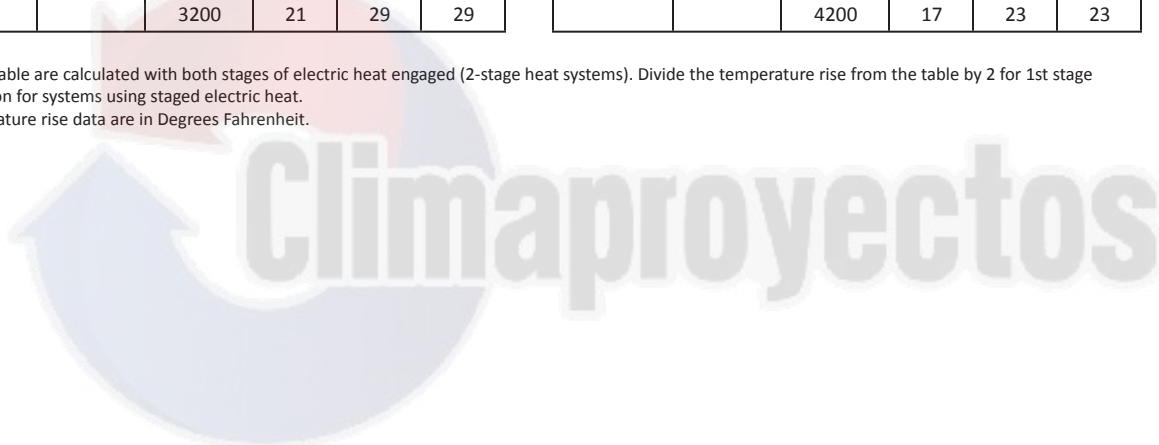

AIR HANDLER	AHKD MODEL	NOMINAL kW	ELECTRICAL DATA	STAGES	WEIGHT (LBS.)	MCA ¹	MOP ²
DAX0904** and DAX1204**	None	N/A	208-240/3/60	N/A	N/A	15.5 / 15.5	20 / 20
	AHKD15-3A	15	208-240/3/60	1	56	56.3 / 62.4	60 / 70
	AHKD20-3A	20	208-240/3/60	2	59	69.4/77.4	70 / 80
	AHKD30-3A	30	208-240/3/60	2	60	95.4/108	100 / 110
	None	N/A	460/3/60	N/A	N/A	5.2	15
	AHKD15-4A	15	480/3/60	1	55	28.3	30
	AHKD20-4A	20	480/3/60	2	57	35.8	40
	AHKD30-4A	30	480/3/60	2	58	50.9	60

¹ Minimum Circuit Ampacity

² Maximum Overcurrent Protection

NOTES:

- These air handlers do not have factory-installed electric heat. The above-listed kits are the ONLY heater kits that can be used with this commercial series. They are available for purchase as field-installed accessories.
- The electrical characteristics of the air handler, electric heater kits, and building power supply must be compatible.



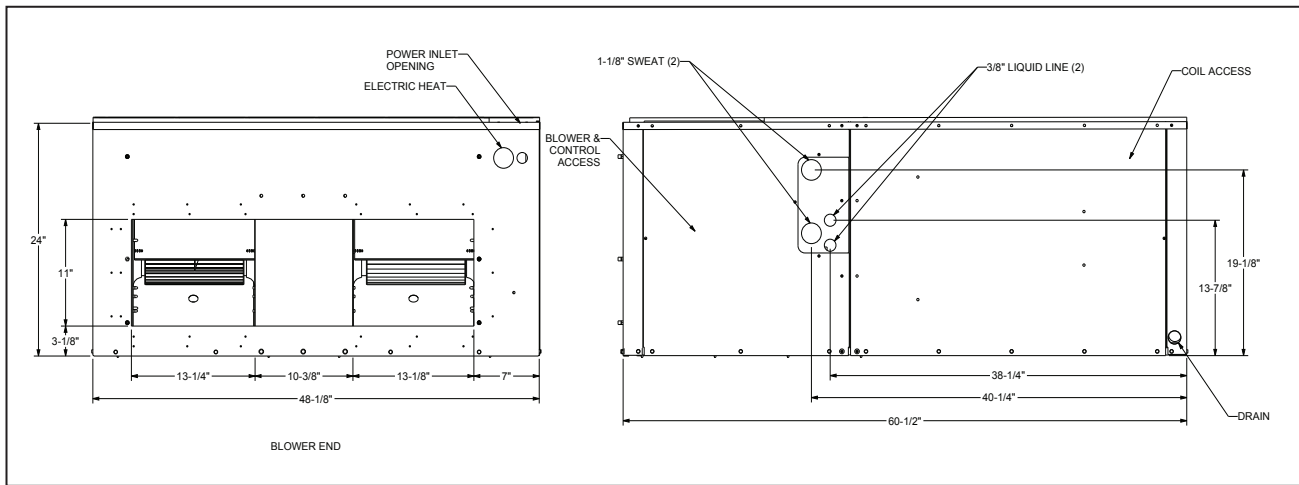

DUCT CONNECTION SIZING WITHOUT ELECTRIC HEATERS

MINIMUM SUPPLY AND RETURN DUCT DIMENSIONS

DIMENSIONAL DATA FOR ELECTRIC HEATER KITS

- 15, 20, & 30 kW Heater Kits
- Supply opening is 13 3/8" x 40 3/8"

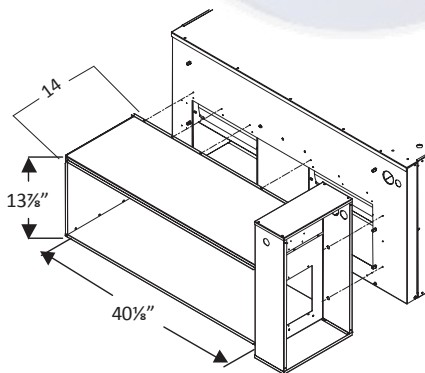

SUPPLY DUCT		RETURN DUCT	
A	B	C	D
13 3/8"	40"	24"	48"

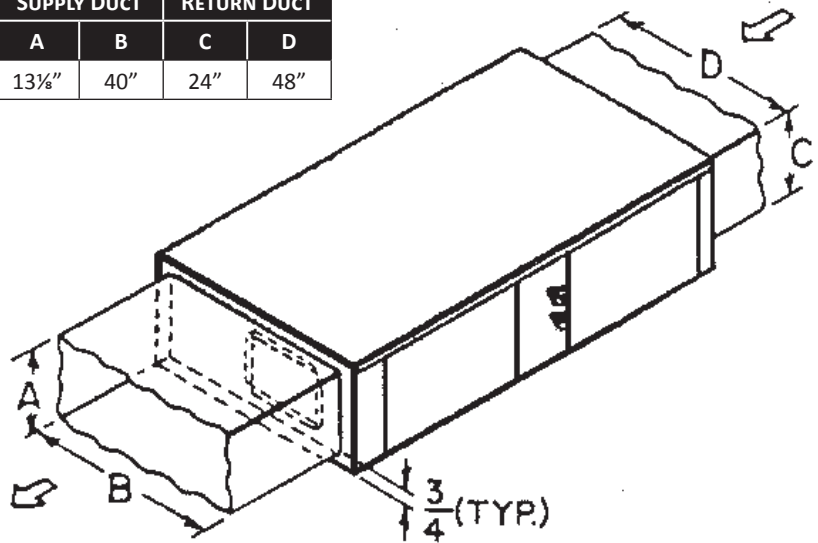

POWER AND CONTROLS WIRING DIAGRAM
DAX 090-120, 3PH

NOTES

- 1 REPLACEMENT WIRE MUST BE SAME SIZE AND TYPE OF INSULATION AS ORIGINAL (AT LEAST 105° C). USE COPPER CONDUCTORS ONLY. USE N.E.C. CLASS 2 WIRE FOR ALL LOW VOLTAGE FIELD CONNECTIONS.
- 2 FAN ONLY AND LOW COOLING MODES (YELLOW WIRE) ARE WIRED TO TB-T1. HIGH COOLING, LOW HEAT, AND HIGH HEAT MODES (BROWN WIRE) ARE WIRED TO TB-T2. MOVE YELLOW AND BROWN WIRES AS NEEDED TO TB-T1 THRU TB-T5 TO MEET INSTALLATION AIRFLOW REQUIREMENTS. SEE UNIT TO MANUAL.
- 3 EFKH IS INSTALLED, CONNECT THE 6 PIN MALE PLUG INCLUDED WITH THE KIT TO THE UNIT'S EKH HARNESS. REFER TO UNIT IO MANUAL FOR BLOWER TORQUE ADJUSTMENTS. TO COMBINE HEATING STAGE 1 & 2, ADD AN 18 AWG JUMPER WIRE CONNECTING TB-W1 AND TB-W2.
- 4 TO INSTALL A THIRD PARTY SAFETY DEVICE, REMOVE RED JUMPER WIRE AND CONNECT A NORMALLY CLOSED DRY CONTACT BETWEEN TB-S1 AND TB-R.
- 5 ORANGE WIRE IS FACTORY TERMINATED TO THE 240/480V TAP. BLACK WIRE IS FACTORY TERMINATED TO THE COM TAP. IF SUPPLY VOLTAGE IS 208V MOVE ORANGE WIRE TO 208V TAP.

FIELD WIRING

- HIGH VOLTAGE
- - - LOW VOLTAGE
- EARTH GROUND

FACTORY WIRING

- HIGH VOLTAGE
- - - LOW VOLTAGE
- OPTIONAL HIGH VOLTAGE
- OPTIONAL LOW VOLTAGE



COMPONENT LEGEND

BC	BLOWER CONTACTOR	BK	BLACK
BM	BLOWER MOTOR	BL	BLUE
BR	BLOWER RELAY	BR	BROWN
CB	CIRCUIT BREAKER	GR	GREEN
EKH	ELECTRIC HEATER KIT	OR	ORANGE
GND	EQUIPMENT GROUND	PK	PINK
SEQ	SEQUENCER RELAY	PU	PURPLE
TB	TERMINAL BLOCK	RD	RED
TR	TRANSFORMER	WH	WHITE
		YL	YELLOW



0140107389A

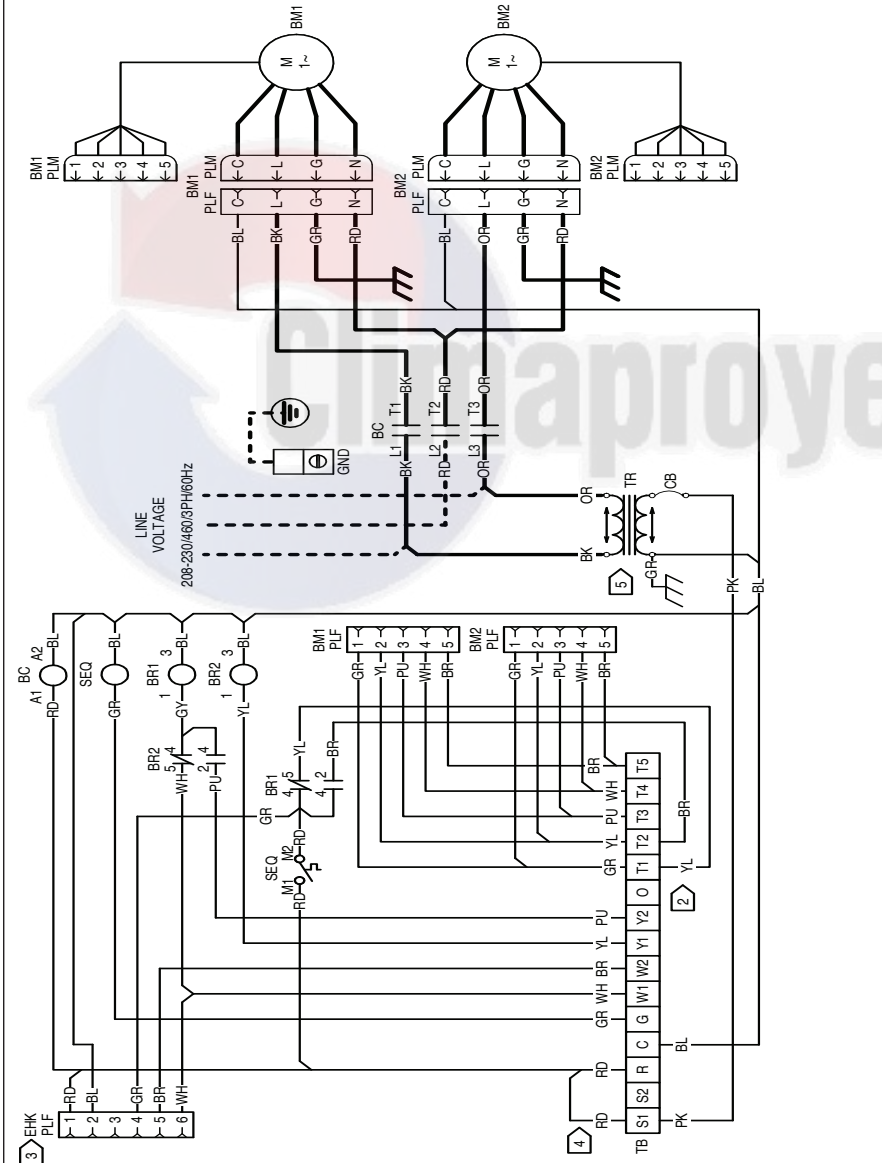

Wiring is subject to change. Always refer to the wiring diagram on the unit for the most up-to-date wiring.



WARNING

High Voltage: Disconnect all power before servicing or installing this unit. Multiple power sources may be present. Failure to do so may cause property damage, personal injury, or death.

1 TWO-STAGE CONDENSER UNIT

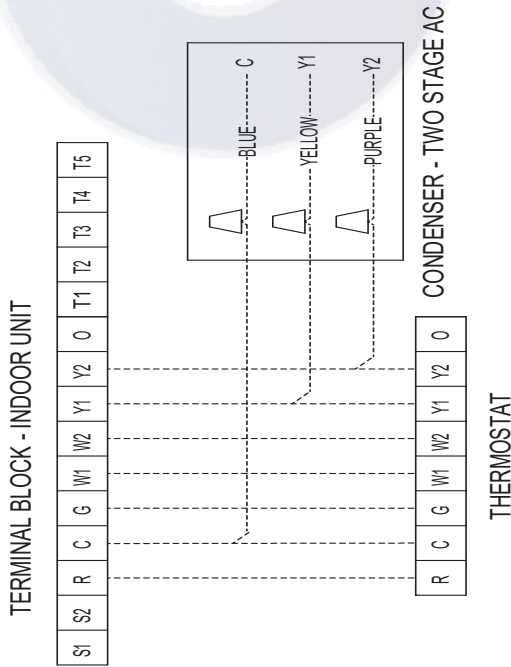

2 ONE-STAGE CONDENSER UNITS

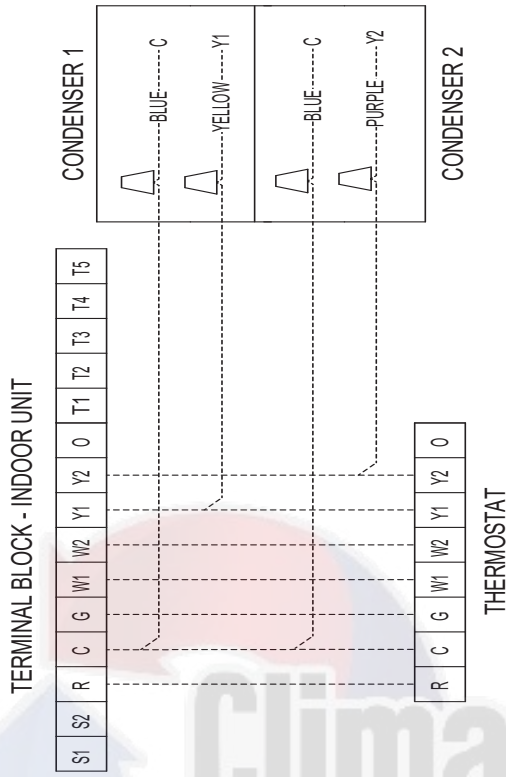

1 TWO-STAGE HEAT PUMP UNIT

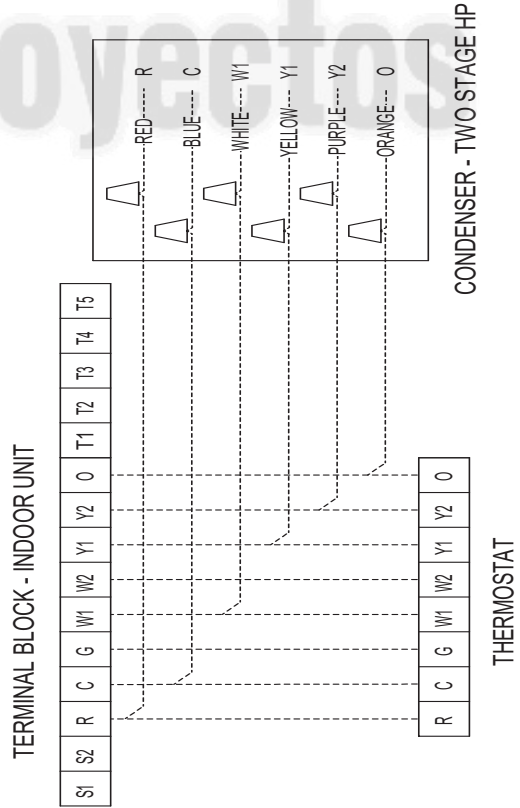

LOW VOLTAGE FIELD WIRING
DAX 090-120, 3PH

NOTE:

THIS IS A SYSTEM WIRING DIAGRAM SHOWING DAX MODEL SERIES WITH FIELD CONNECTIONS. THIS DIAGRAM IS TO BE INCLUDED IN INSTALLATION INSTRUCTIONS. A SEPARATE WIRING DIAGRAM IS CONTAINED INSIDE THE CONTROL BOX FOR UNIT FACTORY WIRING.

	AHKD MODEL	DAX090*	DAX120*
Electric Heat Kits	AHKD15-3A	X	X
	AHKD20-3A	X	X
	AHKD30-3A	X	X
	AHKD15-4A	X	X
	AHKD20-4A	X	X
	AHKD30-4A	X	X
Freeze Protection Kit	FSK04A	X	X
TX3N4	TXV Kit	X	X
TX5N4	TXV Kit	X	X



